

Durham E-Theses

Machinability assessment and tool selection for milling.

Ian D. Carpenter

How to cite:

Carpenter, Ian D. (1996) Machinability assessment and tool selection for milling. Doctoral thesis, Durham University.

Use policy

The full-text may be used and/or reproduced, and given to third parties in any format or medium, without prior permission or charge, for personal research or study, educational, or not-for-profit purposes provided that:

- a full bibliographic reference is made to the original source
- a <https://etheses.durham.ac.uk/id/eprint/1444/> is made to the metadata record in Durham E-Theses
- the full-text is not changed in any way

The full-text must not be sold in any format or medium without the formal permission of the copyright holders.

Please consult the [full Durham E-Theses policy](#) for further details.

MACHINABILITY ASSESSMENT AND TOOL SELECTION FOR MILLING

A thesis submitted to the
University of Durham
for the degree of
Doctor of Philosophy

by

Ian D. Carpenter

The copyright of this thesis rests
with the author. No quotation
from it should be published
without the written consent of the
author and information derived
from it should be acknowledged.



School of Engineering
University of Durham



June 1996

- 9 OCT 1997

Abstract

Over the last few decades, the range of engineering materials encountered in machine shops has increased greatly, as has the variety of cutting tools that are capable of machining these materials. Unfortunately, even as the demands placed upon the metal machining industry have broadened, the level of experience amongst process planners and machine operators has been falling due to natural wastage, the decline of apprenticeship schemes and increasing levels of automation. Therefore, it has become increasingly important for cutting tool manufacturers to provide a complete range of technical support for their products, including machinability information, tool selection and specification of cutting conditions.

This thesis describes the development of a computer based system for automated machinability assessment and tool selection for milling. The system is called OPTIMUM (Optimized Planning of Tooling and Intelligent Machinability evaluation for Milling) and is designed to provide reliable tool selection and cutting data for a range of milling operations. The machinability assessment method employs rule based decision logic and multiple regression techniques to produce feasible initial cutting conditions for a wide range of workpiece materials. A novel feature is that a wide variety of input data is permitted, including imprecise or incomplete workpiece descriptions. The tool selection function implements a robust machining model based on publicly available tool and material data. The model includes the process constraints of tool life, tool size, cutter geometry, insert suitability, spindle speed range and available spindle power. Cutting data is optimized on economic grounds according to the objective functions of minimum cost, maximum production rate or fixed tool life. A new optimization criterion related to initial average chip thickness, called *harshness*, is proposed. Unlike most CAPP systems, a large variety of workpiece materials (more than 750 ferrous alloys) and a comprehensive selection of tools (potentially 35,988 cutter/insert combinations) are considered.

A tool variety reduction post processor facilitates the rationalization of sets of selected tools to produce optimized tool sets for a limited number of available tool positions. All possible sets of tools are considered and no additional cutting data calculation or

modification is required. Most current CAPP systems are 'open loop' but the OPTIMUM system operates within a feedback 'closed loop' that stores approved cutting data from the shop floor. Multiple regression analysis is used to improve the performance of the system in the future based upon this verified historical cutting data.

The software comprises several modules implemented with a relational database management system, Microsoft FoxPro 2.6. A selection of examples are presented to illustrate the capabilities of the system. The advantages of the novel approach of using the powerful combination of knowledge based logic and statistical methods to provide a flexible support tool for process planning milling operations are described and recommendations are made for further development and industrial exploitation.

As always, to my parents and my brother.

To see a World in a Grain of Sand,
And a Heaven in a Wild Flower,
Hold Infinity in the palm of your hand,
And Eternity in an hour.

Auguries of Innocence, 1 - William Blake

Acknowledgements

I wish to express my sincere thanks to my supervisor, Dr. Paul Maropoulos, for all his guidance, encouragement, enthusiasm and friendship over the period of this research. I also owe a debt of gratitude to many other people in (and around) the Manufacturing Research Group at the University of Durham, and in particular Dr. Bubakar Alamin, Professor Ernie Appleton, Mike Betteridge, Hugh Bradley, Liam Keating, Paul Lewis, Rory Barr and Dr. Andy Oliver. At St. Chad's College I was particularly lucky to know Stephen Jarvis, Mark Roberts, Dr. James Blowey, Dr. Duane Arnold and especially Mairi van Looy.

I am grateful to E.P.S.R.C. and S.E.R.C. for providing a CASE research studentship that enabled me to undertake this research project. I have also been extremely fortunate to receive support for my research from Seco Tools, UK and in particular Mr. Leif Larsson, Mr. Hans Åhman, Mr. Mats Simon, Mr. Max Townson and my industrial mentor, Mr. Mike Kingdom. They have all showed me great kindness, generosity and tolerance when helping me to understand what the tool business is really like.

Having moved to Edinburgh, I could not have completed this degree without the support of my new friends and colleagues at Heriot-Watt University, specifically Rick Dewar, Professor John Simmons and Jim Ritchie.

As for thesis writing, I offer my thanks to Tim Cutts, for helping me to keep everything in order, and to Stephen Sondheim, Arvo Pärt, Henryk Górecki and John Tavener for providing the soundtrack.

Finally, I would still be writing this thesis were it not for my “writing support system” - namely Dr. Nick Weston and, of course, my mother, father and brother, Neil.

It has been an adventure.

Table of contents

Title	i
Abstract.....	ii
Dedication	iv
Acknowledgements	v
Table of contents.....	vi
List of figures	xi
List of tables.....	xiv
Declaration.....	xvi
Glossary.....	xvii
Notation.....	xx
Chapter 1: Introduction	1
1.1 Background	1
1.2 Computer aided process planning	3
1.3 Research objectives	4
1.4 Thesis content and structure	4
1.5 Related publications	5
Chapter 2: Literature review	7
2.1 Manual process planning	7
2.2 Computer aided process planning systems	10
2.2.1 Discussion	19
2.3 Cutting data optimization	19
2.3.1 Discussion	32
2.4 Tool Selection.....	32
2.4.1 Discussion	40

2.5 Machinability evaluation.....	41
2.5.1 Chemical composition tests.....	42
2.5.2 Microstructure tests.....	43
2.5.3 Physical properties tests.....	45
2.5.4 Machinability databases	45
2.5.5 Discussion	48
2.6 Summary and conclusions	48
Chapter 3: OPTIMUM - overall system description	51
3.1 Introduction	51
3.2 Functional description	52
3.3 Overall layout.....	54
3.4 Development tools	55
3.5 Data driven application design.....	56
3.6 Operation geometry definition	58
3.6.1 Interfaces with CAD/CAM.....	59
Chapter 4: Machinability assessment	63
4.1 Introduction	63
4.2 Investigation of machinability	64
4.3 Material classification	70
4.3.1 Data sources.....	70
4.3.2 Classification by standard material designation.....	72
4.3.3 Classification by material group	73
4.3.4 Classification by material composition	74
4.3.5 Rule-based systems.....	74
4.3.6 Automatic rule induction methods	75
4.3.7 Formatting of induced rules	77
4.3.8 Uncertainty handling.....	77
4.3.9 Rule firing mechanism	80
4.3.10 Material hardness specification	80
4.4 Real-time regression analysis of standard cutting data.....	81
4.4.1 Data grouping for regression analysis.....	83

4.4.2 Visual feedback and verification of regression calculations	84
4.5 Using incomplete or partially defined input data.....	84
4.5.1 Defaults and reasonableness checking	85
4.5.2 Rule firing with incomplete chemical composition data	86
4.6 Modification of suggested cutting data	86
4.6.1 Modification of axial depth of cut	86
4.6.2 Modification of suggested insert grade.....	87
4.7 Summary and discussion.....	88
Chapter 5: Cutting data optimization and tool selection	89
5.1 Process constraints	89
5.1.1 Geometric tool suitability.....	91
5.1.2 Tool life	93
5.1.3 Cutting forces.....	96
5.1.4 Machine power.....	97
5.1.5 Tool and workpiece deflection.....	98
5.1.6 Chip capacity.....	100
5.1.7 Chatter	103
5.1.8 Surface finish.....	105
5.2 Multiple operation tool selection	107
5.2.1 Feature splitting.....	107
5.2.2 Uneven distribution of radial width of cut between passes.....	108
5.3 Cutting data criteria.....	109
5.3.1 Cutting data objective functions.....	110
5.4 Tool selection criteria.....	110
5.4.1 Tool selection objective functions	111
5.5 Cutting data optimization and tool selection algorithm.....	112
5.5.1 Cutter and insert suitability checking.....	112
5.5.2 Evaluation of the initial cutting parameters	117
5.5.3 Optimization of the cutting parameters	127
5.5.4 Handling of sub-operations	130
5.5.5 User-defined tool sorting	130
5.6 Summary and discussion.....	131

Chapter 6: Tool variety reduction	133
6.1 Introduction	133
6.2 Tool regulation.....	136
6.3 Tool substitution	138
6.3.1 Identical tools.....	138
6.3.2 Identical holder and similar insert.....	139
6.3.3 Compatible holder	139
6.4 Wear balancing.....	139
6.5 Variety reduction method.....	141
6.5.1 Search strategy	143
6.5.2 Sorting of rationalized tool sets	144
6.5.3 User interface	145
Chapter 7: Approved data collection and post-processing	148
7.1 Introduction	149
7.2 Feedback data requirements	151
7.3 Data acquisition methods.....	153
7.4 Conformance assessment methods.....	154
7.4.1 Statistical methods.....	154
7.4.2 Conformance assessment implementation.....	156
7.4.3 Modelling of stochastic behaviour.....	159
7.5 Data availability.....	161
Chapter 8: Testing and results	162
8.1 Machinability assessment examples.....	162
8.1.1 Example 1	164
8.1.2 Example 2	165
8.1.3 Example 3	166
8.1.4 Example 4	167
8.1.5 Summary	168
8.2 Tool selection examples	168
8.2.1 Examples 5 and 6: Geometric constraints.....	170
8.2.2 Example 7: Pocket milling constraints.....	171

8.2.3 Examples 8 and 9: Available power limitation	172
8.2.4 Examples 10 and 11: Feature decomposition.....	173
8.2.5 Examples 12 and 13: Surface finish constraint.....	175
8.2.6 Examples 14, 15, 16 and 17: Effect of workpiece material	176
8.2.7 Examples 18 and 19: Effect of objective function and optimization criteria...	177
8.2.8 Summary	179
8.3 Tool variety reduction example	196
8.4 Conformance assessment example	200
Chapter 9: Conclusions and recommendations for further work	204
9.1 Discussion.....	204
9.1.1 Implementation issues.....	207
9.1.2 Data management and availability	207
9.2 Conclusions.....	208
9.3 Recommendations for further work	211
9.3.1 Recommendations for industrial application	211
9.3.2 Recommendations for further research.....	213
References	215
Appendix A: Data table structures	226
Appendix B: Material groupings	234
Appendix C: Material classification rules.....	238
Appendix D: Multiple regression techniques.....	245
Appendix E: Cutting data regression curves.....	249
Appendix F: ISO classification system for cemented carbide tools	254
Appendix G: Derivation of tool life objective functions.....	257
Appendix H: Calculation of engagement angle	260
Appendix I: Cutter geometry definition	262

List of figures

Figure 3.1: Context diagram of the OPTIMUM CAPP system.....	52
Figure 3.2: Functional layout of the OPTIMUM system	53
Figure 3.3: Top level menu interface of OPTIMUM	54
Figure 3.4: Component record maintenance interface	58
Figure 3.5: Operation definition interface	59
Figure 3.6: The CAM cycle in a feature-based design environment	61
Figure 4.1: Overall layout of machinability assessment module	65
Figure 4.2: Schaeffler diagram for stainless steels	67
Figure 4.3: Stainless steel phase type plotted on the Schaeffler chromium equivalent against nickel equivalent graph	69
Figure 4.4: Selection of material specification method	71
Figure 4.5: Material specification by AISI standard designation.....	73
Figure 4.6: Material specification by material group	73
Figure 4.7: A typical automatically induced rule	76
Figure 4.8: A rule with redundant conditions.....	76
Figure 4.9: A rule with uncertain outcome.....	79
Figure 4.10: Material hardness dialogue box.....	80
Figure 4.11: Polynomial curve fitting by multiple regression on cutting velocity against material hardness for machinability group 4 (free machining carbon steels, wrought - medium carbon resulfurized), finish facing.....	82
Figure 4.12: Graph of regression curves for feed per tooth against material hardness for visual feedback to user	83
Figure 4.13: Multiple regression for interpolation of cutting velocity for a non-standard depth of cut.....	87
Figure 5.1: Layout of the cutting data optimization and tool selection algorithm.....	90
Figure 5.2: A typical milling operation (after Seco Tools AB, 1994).....	100
Figure 5.3: Chatter closed-loop mechanism	103
Figure 5.4: Surfaces generated by a milling cutter.....	106
Figure 5.5: Decomposition of a T-slot feature into a plain slotting operation and a T-slotting operation.....	108

Figure 5.6: Uneven distribution of radial width of cut for a multipass slotting operation.....	108
Figure 5.7: Maximum cutter diameter constraint for slotting.....	114
Figure 5.8: Maximum cutter radius constraint for pocket milling	115
Figure 5.9: Cutter radius constraint for a free form profile.....	115
Figure 5.10: Axial cutter dimension constraints	115
Figure 5.11: Cutting data optimization routine	128
Figure 5.12: Optimum point search route within operation parameter space	129
Figure 6.1: Tool selection levels and interacting technologies	134
Figure 6.2: Reduction of tool change time by wear balancing	140
Figure 6.3: Setting the initial parameters for tool variety reduction	146
Figure 6.4: Results display of the tool variety reduction method	147
Figure 7.1: Functional layout of the approved data feedback system.....	149
Figure 7.2: Multiple regression curve fitting for cutting velocity conformance assessment	157
Figure 7.3: Adjusted cutting data from conformance assessment method	158
Figure 7.4: General structure of a neural network.....	159
Figure 8.1: Example slotting operation geometry.....	170
Figure 8.2: Example pocket operation geometry.....	171
Figure 8.3: Example facing operation geometry.....	172
Figure 8.4: Example T-slot operation geometry.....	174
Figure 8.5: Example square shoulder geometry	176
Figure 8.6: Tool variety reduction example setup	196
Figure 8.7: Tool variety reduction example results	197
Figure 8.8: Multiple regression curve to interpolate adjusted cutting velocity	202
Figure 8.9: Multiple regression curve to interpolate adjusted feed per tooth.....	202
Figure 8.10: Output of conformance assessment module	203
Figure E.1: Regression curves of cutting velocity against material hardness for free machining alloy steels, wrought (medium carbon resulfurized).....	250
Figure E.2: Regression curves of fed per tooth against material hardness for free machining alloy steels, wrought (medium carbon resulfurized).....	250

Figure E.3: Regression curves of cutting velocity against material hardness for free machining alloy steels, wrought (medium and high carbon leaded)	251
Figure E.4: Regression curves of feed per tooth against material hardness for free machining alloy steels, wrought (medium and high carbon leaded)	251
Figure E.5: Regression curves of cutting velocity against material hardness for free machining stainless steels, wrought (martensitic)	252
Figure E.6: Regression curves of feed per tooth against material hardness for free machining stainless steels, wrought (martensitic)	252
Figure E.7: Regression curves of cutting velocity against material hardness for alloy steels, cast (medium carbon).....	253
Figure E.8: Regression curves of feed per tooth against material hardness for alloy steels, cast (medium carbon).....	253
Figure H.1: Engagement angle of a milling cutter	260
Figure I.1: Geometry of cutting edge (after Seco Tools AB, 1994).....	262
Figure I.2: Common cutter rake angle configurations	263

List of tables

Table 2.1: Effect of microstructure on machinability of steels	44
Table 3.1: Milling operation details used for data driven program execution	57
Table 4.1: Sample cutting data from the Machining Data Handbook.....	70
Table 4.2: National and International Material Designation Standards	72
Table 4.3: Example data set for automatic rule induction.....	76
Table 4.4: Extended data record form of a material categorization rule.....	78
Table 4.5: Two materials that produce a rule with uncertain outcome.....	79
Table 4.6: Input and output of machinability assessor	86
Table 4.7: Ratios of cutting velocity for different insert grades for finishing facing, material group 1 (Free Machining Carbon Steels, Wrought).....	87
Table 5.1: Cutter geometry selection guidelines.....	102
Table 5.2: Operation types and associated character codes	113
Table 5.3: Typical operation codes for milling cutters.....	114
Table 5.4: Average chip thickness ranges for typical cutters	119
Table 5.5: Parameters for the calculation of specific resistance to cut	123
Table 6.1: Tool lists for a set of operations.....	143
Table 6.2: Tool list with tool selection weighting values	145
Table 6.3: Sorted list of rationalized tool sets	145
Table 7.1: Approved data structure	152
Table 7.2: Neural network input and output nodes	160
Table 8.1: Example 1	164
Table 8.2: Example 2	165
Table 8.3: Example 3	166
Table 8.4: Example 4	167
Table 8.5: Example 5 results	181
Table 8.6: Example 6 results	182
Table 8.7: Example 7 results	183
Table 8.8: Example 8 results	184
Table 8.9: Example 9 results	185
Table 8.10: Example 10 results	186

Table 8.11: Example 11 results ..	187
Table 8.12: Example 12 results ..	188
Table 8.13: Example 13 results ..	189
Table 8.14: Example 14 results ..	190
Table 8.15: Example 15 results ..	191
Table 8.16: Example 16 results ..	192
Table 8.17: Example 17 results ..	193
Table 8.18: Example 18 results ..	194
Table 8.19: Example 19 results ..	195
Table 8.20: Sample operations for tool variety reduction ..	196
Table 8.21: Example tool sets from the tool variety reduction procedure ..	200
Table 8.22: Approved data records for face milling cast carbon steel ..	201
Table B.1: Material groups and subgroups ..	236
Table B.2: Seco material groups.....	237
Table F.1: ISO classification of cemented carbides ..	255
Table F.2: ISO application ranges for Seco insert grades ..	256

Declaration

This thesis is the result of my own work. No part of the thesis has been submitted for any other degree in this or any other University.

Ian David Carpenter

Durham

June 1996

The copyright of this thesis rests with the author. No quotation from it should be published without his prior written consent and information derived from it should be acknowledged.

Glossary

Machinability

At first glance the definition of the term machinability seems to present few problems. It is a material property that represents the ease or difficulty of machining the material with a cutting tool. The term is widely used in manufacturing industry yet detailed enquiries reveal a certain lack of preciseness about its definition or even its general meaning. Unlike most material properties, there are no generally accepted methods of measurement and it is likely that the term tends to take on a meaning that is closest to the immediate requirements in a machining environment. Thus, machinability might become related to finishability where surface finish is important. In other cases it may be used to describe how uniformly a material behaves when machined on a given machine with a constant set of cutting parameters whilst many engineers might consider machinability to be a measure of the useful life of the cutting tool. In most branches of science and engineering great care is taken to precisely define critical parameters but machinability continues to represent different things for different people.

The term machinability will be used extensively within this thesis and thus it is worthwhile to propose a working definition with regard to this research. In these days of highly efficient, semi-automated machine tools, the actual cutting time is becoming an increasingly important part of the overall machining cost. As new tools and insert grades become more resilient and versatile it is vital to use as much of the capacity of the tool as possible and this will be reflected in a high metal removal rate (after all, the efficient removal of metal is the one of the primary reasons for machining). High metal removal rates will be reflected in the cutting conditions used. So a working definition of machinability might be:

Machinability is a material parameter that is a measure of how easy or difficult it is to remove material by cutting. It can be described by specific cutting conditions.

In this form we may say that the assessment of machinability is the process of finding suitable cutting conditions for a given material and tool combination.

Milling

Milling is a versatile machining process by which new surfaces are generated by the action of a rotating cutter that is progressively fed into the workpiece in a direction perpendicular to the axis of the cutter. This is accomplished by the use of a milling machine which provides relative motion between the cutter and workpiece. Generally the cutter is held in a rigid spindle that can move vertically only and the workpiece is securely clamped to a table that can be fed under control in either of the other two orthogonal directions. Unlike turning, it is possible, with a Computer Numerical Control (CNC) milling machine, to create a vast array of three dimensional component geometries. Almost all milling cutters feature more than one active cutting tooth and the cutting action is considerably more complex than that for turning.

Process planning

The Society of Manufacturing Engineers defined process planning as '*the systematic determination of the methods by which a product is to be manufactured economically and competitively*'. This can usually be seen to involve a series of steps. The first is the interpretation of the design data which is often held in engineering drawings or, more recently, in a CAD or solid modelling system. The essential requirements of the product such as batch size, raw material, tolerances, surface finishes, material treatment and other specialized factors are then studied and evaluated. Then the machining process is selected, often according to company specific strategy. Machine tools must be selected considering parameters such as availability, capacity and production rate. The sequencing of the operations, workholding and fixturing and cutting conditions are all related and are often assessed according to company specific goals. Finally the process plan must be disseminated in a suitable form, often as process sheets, operation sheets, route sheets and part programs.

Features

In production planning, it is desirable to be able to derive a set of suitable manufacturing processes directly from the design features of the workpiece. Much recent research work has concentrated on the description of workpiece geometries as groups of 'features', either derived from a feature based design process or from automated feature recognition. Rembold *et al.* (1993) describe a feature as "*a specific geometric configuration formed on the surface, edge, or corner of a workpiece that is intended to aid in achieving a given function*". Nnaji and Liu (1990) define a feature as "*a set of surfaces together with specifications of the bounding relationships between them which imply an engineering function (or stereotypical entity) on an object and which may be formed on the faces, edges, or corners of an object*". This definition implies that not all the surfaces of an object are feature surfaces.

In this research, the term feature is used to describes the typical configurations of machined surfaces that can be simply created with standard milling cutters, such as a face, square shoulder, straight slot, rectangular pocket and T-slot. Thus the term *feature* is largely synonymous with the term *operation* although some features, such as a T-slot, may actually require more than one simple operation to be created.

Notation

This section presents a comprehensive list of all the algebraic notation used within this thesis, along with a short description and the appropriate standard units, if any. For ease of reference, brief descriptions are also given at the first occurrence of any item of notation in each chapter.

ϕ_s	engagement angle of cutter (rad)
α	exponent affecting the cutting velocity in the tool life equation
α_2	exponent affecting the engagement angle in the tool life equation
α_3	exponent affecting the cutter diameter in the tool life equation
a_a	axial depth of cut (mm)
a_{amax}	maximum axial depth of cut for a cutter (mm)
a_{amin}	minimum axial depth of cut for a cutter (mm)
a_{rmax}	maximum radial depth of cut for a cutter (mm)
a_{rmin}	minimum radial depth of cut for a cutter (mm)
β	exponent affecting the feed per tooth in the tool life equation
B	radial width of cut (mm)
B_L	length of the parallel land on an insert (mm)
B_{lim}	limiting value of radial width of cut (mm)
C	a constant in Taylor's tool life equation
C_1	a constant in the simplified extended Taylor's tool life equation
C_2	a constant in the extended Taylor's tool life equation
C_3	a constant in the tool life equation of Yellowley & Barrow
C_4	a constant in the tool life equation of Lau
c_u	percentage of cost of cutter that is absorbed by each operation
C_{axial}	constant in the specific resistance to cut equation
c_h	cost of cutter (£)
c_i	cost of insert (£)
C_{rad}	constant in the specific resistance to cut equation
C_{tang}	constant in the specific resistance to cut equation
c_{total}	total cost of machining operation (£)
CV	current chip volume (mm ³)
D	effective cutter diameter (mm)
d	insert diameter for round inserts (mm)
e	eccentricity of cutter centre from centre of cut (mm)
ε	exponent affecting the thermal fatigue parameter in the tool life equation
E_{rad}	exponent in the equations for radial specific resistance to cut
E_{tang}	exponent in the equations for tangential specific resistance to cut
E_{axial}	exponent in the equations for axial specific resistance to cut
F_{total}	total resultant cutting force (N)
γ_f	tool radial rake angle (°)
G_{min}	minimum value of the real part of the cross receptance (mm/N)
γ_o	tool orthogonal rake angle (°)

γ_p	tool axial rake angle ($^\circ$)
η	efficiency of power transmission (%)
h	instantaneous chip thickness (mm)
H	total axial depth of the operation (mm)
<i>harshness%</i>	level of harshness for initial average chip thickness
h_D	nominal chip thickness (mm)
h_{max}	maximum chip thickness for a specific cutter (mm)
h_{min}	minimum chip thickness for a specific cutter (mm)
h_{step}	step change value for average chip thickness (mm)
h_{zm}	average chip thickness (mm)
κ	cutter approach angle ($^\circ$)
K_1	non-productive cost (£)
K_2	machining cost (£)
K_3	cutting edge(s) change cost (£)
K_4	tool cost per component (£)
$k_{c1.1}$	parametric description of specific resistance to cut ($N/mm^{2\circ}$)
k_{sm}	specific resistance to cut (N/mm^2)
$k_{sm.axial}$	specific resistance to cut in the axial direction (N/mm^2)
$k_{sm.rad}$	specific resistance to cut in the radial direction (N/mm^2)
$k_{sm.tang}$	specific resistance to cut in the tangential direction (N/mm^2)
L	length of cut for one pass (mm)
L_{total}	total length of cut (mm)
m	metal removal rate (mm^3/min)
mc	exponent in parametric expression of specific resistance to cut
n	constant in Taylor's tool life equation
n	initial cutter angular velocity (rpm)
ND	depth of the neck of a T-slot (mm)
n_{ce}	number of cutting edges per insert
N_{eng}	maximum number of instantaneous tooth engagements
n_i	number of inserts on a cutter
NW	width of the neck of a T-slot (mm)
p_a	number of axial passes
P_{cut}	cutting (spindle) power (W)
P_{eff}	effective power available (W)
p_r	number of radial passes
P_{spin}	power at spindle (W)
R	cutter radius (mm)
r	dynamic cutting force coefficient (N/mm^2)
R_a	surface finish - centre line average (mm)
r_c	corner radius of a pocket or closed slot (mm)
r_e	tool nose radius (mm)
rha	peak to valley roughness (mm)
rnc	number of components that a tool can machine
R_t	peak to valley roughness (mm)
S_{eq}	equivalent feed rate (mm/min)
S_n	feed per revolution (mm)
S_{table}	table feed (mm/min)
S_z	feed per tooth (mm)
T	tool life (min)

t_1	non productive time (min)
t_2	total cutting time (min)
t_3	insert change time (min)
T_{active}	active tool life (min)
T_{cut}	cutting torque generated (Nm)
T_{exp}	expected tool life (min)
T_{oc}	tool life for minimum cost (min)
T_{ot}	tool life for maximum production rate (min)
T_{spin}	torque at spindle (Nm)
t_{total}	total production time for one operation (min)
u_a	axial usage of the cutter (%)
u_{amax}	maximum axial usage of the cutter (%)
u_{amin}	minimum axial usage of the cutter (%)
u_r	radial usage of the cutter (%)
u_{rmax}	maximum radial usage of the cutter (%)
u_{rmin}	minimum radial usage of the cutter (%)
v	tangential cutting velocity (m/min)
v_{chat}	limiting cutting velocity for the onset of chatter (m/min)
v_{oc}	cutting velocity for minimum cost (m/min)
v_{ot}	cutting velocity for maximum production rate (m/min)
v_x	cutting velocity for a tool life of x minutes (m/min)
W	total radial width of the operation (mm)
w_c	weighting factor applied to total operation cost in tool sorting
$wear$	tool wear per component (%)
w_m	weighting factor applied to metal removal rate in tool sorting
w_{rank}	total ranking weight applied to a tool and associated cutting parameters
w_T	weighting factor applied to tool life in tool sorting
w_{time}	weighting factor applied to total operation time in tool sorting
x	cost rate of machine tool (£/min)
X	thermal fatigue parameter
y	cost per set of cutting edges (£)
ψ	insert trailing angle (°)
z	number of teeth on the cutter

Chapter 1

Introduction

Man is a tool-using animal....
Without tools he is nothing, with tools he is all.

Sartor Resartus, bk. i, ch. 5 - Thomas Carlyle

This chapter reviews the background to the various elements of computer aided process planning and presents the objectives of the research reported in this thesis. These are followed by a brief summary of the thesis structure.

1.1 Background

A manufacturing plant is probably one of the most complex systems that a modern engineer can encounter. The manufacturing process can often appear to be secondary to the considerable efforts made in supporting areas such as marketing, accounting and other organizational functions. However, efficient manufacturing planning holds the key to guaranteed productivity gains - no matter how good the marketing, if the product is made in a slow, costly manner, it is unlikely to succeed.

The last three centuries have seen a remarkable degree of progress in the field of manufacturing and in particular metal working. During the early stages of industrialization in the eighteenth century, a lack of standard manufacturing practices meant that volume production involved craftsmen producing products that were functionally identical but geometrically unique. The requirement for interchangeable parts to allow easy repairs to firearms led to a much enhanced uniformity of production.

Whereas previously the final form of a product was left to the machine operator, a consistent method of manufacturing planning was needed to satisfy the concept of interchangeability. Parts had to be made with only a small variance - functional conformance was no longer enough [Chang & Wysk (1985)].

The twentieth century has seen extensive scientific study of metal cutting and mass production. The American engineer Frederick W. Taylor (1856-1915) had a great impact on two fronts: his creation of the philosophy of scientific management and his lifelong study of metal cutting processes. His seminal 1907 paper 'On the Art of Cutting Metals' proposed a relationship between tool life, feed rate and speed, based upon some 50,000 experiments producing 800,000 lb. of metal chips.

Further advances prompted by defence manufacturing led to the development, in the 1950's, of Numerically Controlled (NC) machine tools that could be programmed to perform a wide variety of machining operations. More recently, digital computers have been used to provide Computer Numerically Control (CNC) machining centres and this remains the standard method for tool control today.

Whilst CNC machines can provide considerable benefits of improved efficiency of machining, a significant economic expense still exists before these machines can be fully exploited. This expense is incurred by the considerable planning exercise that is required. Machine tools have taken over many of the control functions previously provided by an operator and components have become increasingly complex. However, greater manufacturing efficiency is constantly expected and thus the level of complexity of planning has still increased significantly.

The alternative to this extensive setup period is the integration of computer aided design (CAD) and computer aided manufacture (CAM). In a computer integrated manufacture (CIM) system, the parts are modelled on a CAD system and process plans and machine instructions for CAM are automatically generated from these models. CAD/CAM and solid modelling systems are now available in a refined and functional form although process planning is still a subject of intense research effort.

1.2 Computer aided process planning

Computer Aided Process Planning (CAPP) is an important part of CIM that has emerged over the last thirty years. According to Steudel (1984), CAPP refers to all those computerized procedures whose aim is to *“translate part design specifications from an engineering drawing into the manufacturing operation instructions required to convert a part from a rough to a finished state”*. Process planning is often described as the intermediate stage between design and manufacture. It is becoming increasingly significant as, with manually operated machines being gradually replaced with flexible and efficient automated equipment, actual production times are being constantly reduced and thus the process planning activity is occupying a greater proportion of the total manufacturing time.

Most published CAPP research deals with turning operations or simple 2.5D geometries with rather less research reported for milling. As the manufacturing market becomes truly global, the operating requirements of any CAPP system become ever more complex. In particular, the proliferation of engineering materials, defined by many national standards, and the large portfolios of tools currently available make the tool selection and cutting data optimization problems especially demanding.

The requirements placed upon modern CAPP systems can be affected by many other factors. Concurrent engineering is an industrial philosophy that is finding considerable favour amongst world class companies. To enable manufacturing engineers to make an effective contribution to the early conceptual design stages of a project, a CAPP system must be able to handle imprecise or incomplete component descriptions and still deliver feasible but conservative process planning information.

In response to these modern CAPP requirements, the research detailed in this thesis has resulted in the design, development, implementation and testing of a flexible and robust machinability assessment and tool selection system which incorporates several elements of the complete CAPP functionality. The system is called OPTIMUM - Optimized Planning of Tooling and Machinability evaluation for Milling.

1.3 Research objectives

The objectives of this research were as follows:

1. To investigate the development a flexible method for the automated assessment of machinability characteristics of new or partially defined materials for a wide range of material types.
2. To investigate and develop an algorithm for tool selection and rapid calculation of optimized cutting conditions in a form that could be used as a remote technical support system by a tool manufacturer.
3. To develop and test tool variety reduction methods that can be applied to the output of the tool selection algorithm.
4. To create an interface for the feedback of approved shop floor cutting data and to analyse this data to refine the cutting data calculations for future jobs.
5. To implement the required functionality, providing a user friendly interface to allow further integration and exploitation *within industrial environments*.

The algorithms devised for these objectives are not intended to produce fully automatic process planning but rather to perform as a sophisticated technical decision support tool for engineers involved with the tooling process and in particular process planners, tooling experts and salesmen, production engineers and machine operators.

1.4 Thesis content and structure

This thesis is divided into eight further chapters which can be summarized as follows:

Chapter 2 contains a review of published literature in several related areas, including manual process planning, computer aided process planning, cutting data optimization, automatic tool selection, machinability testing and machinability databases.

Chapter 3 introduces the overall layout of the OPTIMUM system. The system is placed in the context of a broader manufacturing environment and some possible links to other CAM software, particularly solid modellers, are discussed.

Chapter 4 presents the machinability assessment method which is designed to provide reliable initial cutting conditions for a wide range of workpiece materials and surface conditioning. It is highly tolerant of differing amounts of input data and can operate effectively with incomplete material and operation descriptions.

Chapter 5 examines the major constraints on cutting data in the milling process and proposes an efficient algorithm for generating optimized cutting data and selecting an optimal tool set based upon objective functions and selection criteria specified by the user.

In Chapter 6 an examination of the field of tool regulation and rationalization is provided. These processes are required to reduce setup times and balance tool wear when applying a set of optimal tools to a group of scheduled operations on a machining centre with limited preset tool holding capacity. A simple and exhaustive method for reducing tool variety in tool sets generated by the method described in the previous chapter is explained.

Chapter 7 covers the recovery of verified cutting data from the shop floor and the use of such data to increase the reliability and accuracy of the cutting data optimization method in the future. A prototype conformance assessment method based upon multiple regression is described.

Chapter 8 presents a number of examples of test operations and the typical system output. The capabilities of the system are demonstrated and the output is compared with standard cutting data.

Finally, Chapter 9 draws conclusions from the research and reviews the opportunities for industrial exploitation and further research.

1.5 Related publications

This thesis presents the author's own work except for appropriately acknowledged related work. Earlier work in progress and software developments have also been

documented in internal reports of the University of Durham, technical articles and refereed papers. These include:

- “*A new method for the flexible definition of machinability for milling operations*” [Carpenter & Maropoulos (1995)], and “*A novel machinability assessor for ferrous alloys*” [Carpenter & Maropoulos (1994b)], in which the theory of flexible machinability assessment is discussed (Chapter 4).
- “*Milling decisions*” [Carpenter & Maropoulos (1994a)], which contains a description of the early prototype tool selection module in the context of the whole system (Chapters 3 and 5).
- “*A decision support system for process planning milling operations*” [Carpenter & Maropoulos (1993)], in which an earlier version of the tool selection and cutting data optimization method is described (Chapter 5).

Chapter 2

Literature Review

Throughout the industrial age, metal cutting has played a crucial rôle in the manufacture of parts. As the skills of machine operators have become *complemented by efficient and reliable semi-automated machine tools*, actual cutting times have decreased dramatically. Thus, the proportion of the manufacturing time that is consumed by process planning has increased to the stage where it can account for 40% of the total preparation time [Weill *et al.* (1982)]. This chapter consists of a review of published literature relating to process planning and associated tasks. Whilst the emphasis is on planning for milling operations, details of work on turning are also included as much can be learnt from single point cutting that can be extended for the more complex multiple point, interrupted cutting found in milling.

2.1 Manual process planning

Over the last century or so, many methods have been suggested for producing feasible cutting conditions. These methods broadly fall into two groups:

1. Use handbooks or data tables
2. Employ mathematical programming techniques

The first approach is the oldest, dating back to the earliest years of metal cutting in industry. It involves establishing cutting conditions from the available literature. Tables of cutting data can be found in training manuals which often list applicable ranges of cutting velocities for a small number of workpiece materials using High Speed Steel

(HSS) or carbide inserts. A wider selection of cutting information may be found in some engineering handbooks [Drozda & Wick (1983)]. One of the most detailed and comprehensive sources of cutting recommendations is the *Machining Data Handbook* [Metcut Research Associates (1980)] which includes cutting velocities for a wide range of materials (about 1500 different engineering alloys) with a variety of depths of cuts, feeds and material conditions (such as cold drawn, normalized or annealed). Catalogues and handbooks produced by tool manufacturers [Seco Tools AB (1994), Sandvik (1993)] also provide suggested cutting parameters for their own ranges of cutting tools applied to different engineering materials.

Although there are some differences in the sources mentioned above, particularly in the realms of workpiece material categorization and classification, tool specifications and required input data, they all share essentially the same procedure for establishing cutting conditions which may be summarized as follows:

1. Select the workpiece material

Many cutting data sources cluster materials into groups that exhibit similar cutting characteristics.

2. Select the type of operation

The majority of cutting data tables are for turning and milling. For milling the tables are split into further sub-types such as face milling, square shoulder milling, slot milling, pocket milling and slab milling.

3. Select the tool holder

The overall geometry of the holder is dependent on the machining operation under consideration.

4. Select the tool cutting material

Documentation from tool manufacturers often includes recommended specific insert carbide grades for groups of common materials.

5. Select other parameters

Other parameters might include coolant conditions, tooth coarseness and insert mounting mechanism and the axial and radial depths of cut.

6. Look up the recommended cutting velocity (v) and feed per tooth (s_z)
Often a value of s_z must be chosen by the user and the tables then provide a value of v .

Although this method of establishing cutting conditions is straightforward to perform, it does suffer from several limitations:

1. It is a time consuming and occasionally confusing process to locate the correct tables for a certain workpiece/tool material combination. This is further compounded by the wide ranges of material designation systems and proprietary or semi-proprietary tool designations used by manufacturers.
2. It is necessary to maintain large books of data tables which correspond to a wide range of workpiece materials and tool types. However, much of this data will probably never be used.
3. Recommended data are often given in the form of ranges of values. Many cutting parameters are interrelated such as average chip thickness (h_{zm}), feed per tooth (s_z) and cutting velocity (v). Skill is required to assess which combinations are likely to be successful and it is likely that an inexperienced user will not be sure which values within these ranges are appropriate.
4. Many data sources are not comprehensive. Often support for non-ferrous alloys is weak compared to the details available for ferrous materials.
5. The user must choose suitable values for certain parameters not suggested by the literature. For instance, few recommendations are given for choosing the best tooth pitch on a selected size and shape of cutter [Sandvik (1985)]. Also cutting velocities are often presented corresponding to several discrete values of s_z - the user must select a specific value of feed per tooth.
6. Some parameters present an unsatisfactory simplification of the real geometry. For instance, recommending a value or range of s_z is not strictly correct as s_z is dependent on the average chip thickness (h_{zm}), the cutter width (D), the radial width of cut (B) and the cutter eccentricity (e).
7. The user is generally unaware of the underlying objective that the suggested data are designed to fulfil. Technical staff from Seco Tools explained that the

data presented in their documentation is generated over a series of tests on well maintained equipment (stiff machine tool, rigid workholding, sharp tools etc.). The emphasis is on providing conservative and highly feasible cutting data that will provide a safe starting point for most customers. Little attempt is made to optimize the data.

The second approach involves modelling many aspects of the cutting process mathematically [Smith & Tlustý (1991)]. The characteristic responses of the cutting process, such as tool life, power consumption and cutting force, are represented by equations rather than large tables of discrete values. This substantially reduces the amount of data storage space required. Process constraints that are difficult for a user to evaluate may also be considered and objective functions reflecting company policy may be implemented to produce *optimized cutting solutions*. The large amount of data manipulation and calculation required for mathematical modelling has meant that computers have been widely used in this area. Indeed, as computing hardware has become faster and cheaper, the level of detail included in such mathematical models has increased to the point where current systems include a wide range of technological information and process constraints. A review of computer aided process planning systems is contained in the following section.

2.2 Computer aided process planning systems

Since the early days of the digital computer age, much effort has gone into the task of using computers for the automatic generation of process planning information [Niegel (1965)]. However, many of the computer systems of the 1960's and the 1970's were large, expensive and not well suited to manipulating the significant amounts of data and knowledge that is required in the manufacturing engineering domain. With advances in circuit miniaturization and integration, the first working systems appeared in the late 1970's. The rapid development of CAD and CAM software in the last two decades has demonstrated the need for efficient automated process planning strategies to allow all functions within manufacturing industry to benefit from the advantages in time and cost afforded by company-wide integrated manufacturing systems. The requirement for such systems is further reinforced by the fact that it is difficult for experienced process

planners to gain expertise in the application and usage of the ever increasing range of modern cutters and inserts.

It is perhaps worthwhile at this stage to outline some of the general functions that could be expected to be provided by a process planning system. Several published reviews [Weill *et al.* (1982), Eversheim & Schulz (1985), Alting & Zhang (1989), Maropoulos (1995a), (1995b)] display agreement as to what these functions are although the sequence of functions is open to some debate. Alting and Zhang (1989) list the ten main functions that are provided by a process planning system as:

1. Interpretation of product design data
2. Selection of machining processes
3. Selection of machine tools
4. Determination of fixtures and datum surfaces
5. Sequencing of operations
6. Selection of inspection devices
7. Calculation of tolerances
8. Determination of reasonable tools and cutting conditions
9. Calculation of overall process times
10. Generation of process instructions (including NC data)

Embracing many of these functions, there are two main methods of CAPP that can be found in the current literature: the variant method and the generative method [Alting & Zhang (1989)]. The variant approach was the first to be explored and forms a logical computer aided extension and formalization of the methods that process planners have used for many years. As such, it is the form of CAPP which is easiest to introduce into a traditional manufacturing environment. New process plans are generated by retrieving a stored and verified process plan of a similar component and making modifications to that plan so that it will produce exactly the required component. To identify similarities between parts, it is necessary to group the process plans into families of similar plans. The computer is largely used for its data processing power, having the ability to perform complex searches on large amounts of data and also to rapidly calculate the changes

required to align the process plan with the new component. Thus this approach may be seen as using the computer to assist rather than to replace a process planner. The advantages of this approach are that it forces the process planner to categorize parts into families and produce standard process plans that will produce all the members of these families. This standardisation process can reduce duplication and lead to more consistent and reliable plans. The disadvantages are that an experienced process planner is still required to maintain the sets of verified standard plans and also any errors or inefficiencies in a standard plan may be propagated into newly generated plans. Also variant systems are not well suited to manufacturing environments with high variety as a large number of standard plans will be required with only a few variant plans being generated from them. However, according to Alting and Zhang (1989), the variant method of CAPP has gained widespread popularity compared to the generative method for two principle reasons:

1. The investment required is less and the development cycle is shorter
2. The costs of software and hardware are lower

The generative method of CAPP involves using a computer to generate a specific process plan for a part without referring to any standard or previously verified process plans. It uses rule bases, constraint algorithms, formulae, decision trees and geometric data to produce an efficient strategy for producing the component from the initial blank geometry [ElMaraghy *et al.* (1993)]. Ideally a generative system is completely automatic although, due to the complexity of the process planning activity, it is generally difficult to avoid some form of user intervention or supervision. This may be seen as desirable because, in order to generate a sense of confidence in the user, it is important for the user to have a feeling of control in the running of the system. The generative approach has the advantages of allowing highly specific and optimized process plans to be generated for a wide variety of components without the overhead of a process planner maintaining a library of standard plans. On the other hand, the software development process for a generative CAPP system is often fairly complex and requires a substantial investment of time and labour.

There also exists a form of hybrid method, known as a semigenerative system. This is similar to a generative system in having a full set of generative algorithms but it also includes a facility to allow the generated plan to be compared with sets of past process plans from the individual manufacturing environment, thus bringing the process plans even closer to what can be achieved in reality. Although these systems produce company dependent results, they present a useful practical compromise that can be more easily introduced into industry than the step change of a fully generative system.

As the research and industrial community strive towards a fully integrated manufacturing system it has become clear that *the automation of process plans is a vital part of this process*. Various surveys of CAPP research exist in the literature. One of the largest [Alting & Zhang (1989)] lists 156 different systems. Many of these systems are of the variant type and exist in a prototypical state that only caters for a limited set of component geometries and tooling types. Various common techniques emerge as being useful for the tool selection and cutting data optimization that forms part of some CAPP systems. The optimization of cutting conditions is often reduced to a multiple objective optimization problem. Common objectives include high metal removal rates and satisfactory tool life, although these criteria will tend to conflict with each other. “Optimal” solutions to this problem have been achieved using various mathematical techniques, such as geometric programming [Ermer (1971), Petropoulos (1973), Jha (1990), Gupta *et al.* (1994)], Lagrangian multipliers [Ostafiev *et al.* (1984)], differential calculus [Fenton & Gagnon (1993)], linear programming [Mathieu & Bourdet (1987), Luebbe & Finch (1992), Sotirov *et al.* (1992)], chance-constrained programming [Armarego *et al.* (1993)], dynamic programming [Shin & Yoo (1992)] and linear approximation [Tan & Creese (1995)].

Alternatively, cutting conditions evaluation has been approached using knowledge-based methods [Yeo *et al.* (1991), Kiritsis (1995)] and neural networks [Wang (1993), Garrett *et al.* (1993), Huang & Zhang (1995), Narayanan (1995)]. Both these techniques can provide the flexibility required to handle the widely varying machining responses shown by the full range of engineering materials and tool types. However, it is widely acknowledged that the knowledge engineering problem, particularly knowledge

representation and elicitation, still requires considerable investigation. This tends to make such systems highly complex and demanding to build and maintain.

The remaining part of this section of the literature review presents brief analyses of significant CAPP systems for prismatic parts, particularly in regard to levels of overall capability and the processes of cutting tool selection and calculation of process parameters.

APPAS [Wysk (1977)] is notable for its interesting method of describing the surface to be machined. The surface is described by a single data string comprising between 30 and 40 attributes which are interrogated in a decision tree to arrive at detail process descriptions. The tooling selection and cutting parameters are either extracted from tables or provided by an optimization method. APPAS was later extended to form CAD/CAM [Chang & Wysk (1985)] which demonstrates CAD/CAPP integration within an extended graphical user interface. Unfortunately, this system is limited to just hole making operations. One of the first systems that fully integrated generative process planning with CAD was TIPPS [Chang & Wysk (1984)]. The user may select the surface to be machined using a cursor on screen and suitable tools are selected from a database using dimensional and geometric constraints. Cutting parameters are extracted from stored tables.

AUTAP(Prism) [Eversheim & Esch (1983)] was developed at Aachen Technical University and constitutes an extension of the earlier AUTAP system which only dealt with turned and sheet parts. Components are described by constructions of base elements and modifying features presented by the system (similar to a CSG modeller but much less general). Further elements and features specific to manufacturing may be defined and the overall dimensions of the part are used to select a suitable material. The system then proceeds to determine all the possible manufacturing operations and sequences. Further modules select tools, jigs and fixtures and machining times. Finally manufacturing costs and the economical batch size are calculated to allow the most economical sequence to be found. The exact algorithm for the selection of tools and cutting conditions is not given although an earlier system, dealing with just sheet metal and rotational parts,

shows a company specific method based on geometrical constraints and the workpiece/tool material combination [Eversheim & Holz (1982)].

A combination of the variant and generative approaches is demonstrated by the ICAPP system [Eskicioglu & Davies (1983)]. It deals with eight features derived from eight common machining operations. There are three types of scheduling available and most of the functions can be executed in interactive or automatic mode. Automatic tool selection may be carried out in two different ways: the ICAPP default tool selection method which picks the first tool in the tool file found to be suitable, or the 'Cutting Technology File' method. This file contains the variant planning data and the parameters of the generative logic. Cutting parameters are calculated based upon an analysis of handbook data and company specific shop floor data. For each type of operation the relationship between cutting speed and material hardness and that between feed and hardness are approximated by a straight line. This semigenerative approach suffers from a greatly simplified cutting data calculation method with little technological or constraint information and a default tool selection method that depends on the order of tools stored in the tools database. ICAPP has been interfaced with a wireframe CAD model using the IGES data transfer format [Park & Davies (1987)]. This work has also been extended to include automatic feature extraction for 2½D components [Park *et al.* (1990)].

A proposed system called SIPPS [Liu & Allen (1986)] aims to combine a generative process planning system with the variant model more commonly found in industry via an automated coding and categorization system. Geometric component information is entered from a CAD system and stored in a database. Descriptive component data are checked and classified automatically by the system and duplicate information is eliminated. A free form code is assigned to each component that reflects its size, shape and method of manufacture. Cutting conditions are selected by the user from a table of default data that can be maintained by the user.

An application of the theories of group and type technology to automated process planning produced the SAPT system [Milacic *et al.* (1987)]. Group technology is applied to cylindrical parts whereas type technology can be used to classify more complex

prismatic parts. These concepts are demonstrated by the use of type forms (elemental features) that correspond with certain technological sequences. Process selection is performed by an optimization process although no details are given. SAPT forms a part of the larger DESIGNER system which aims to provide an expert system based solution for conceptual design, process planning and production control.

XMAPP [Inui *et al.* (1987)] solves the expert process planning problem by utilising advanced product modelling techniques. Software is used to store a 'product model' that contains a wide range of engineering information that is required for the full range of manufacturing activities. The comprehensive nature of this model facilitates the solution of some particularly difficult problems such as design of component blanks.

At Kobe University in Japan, research on incorporating the 'know-how' of production engineers in a CAPP system has led to the creation of KAPPS [Iwata & Fukada (1987)]. It comprises four main modules: the CAD and data input interfaces, the decision logic systems, the knowledge and data bases and the know-how acquisition systems. The decision logic handles eight manufacturing problems:

1. Machined surface recognition
2. Rough blank shape recognition
3. Reference surface selection
4. Preference relation determination
5. Machine tool selection
6. Cutting parameters determination
7. Cutting tool selection
8. Fixture selection

These problems are solved using the forward chaining method on a search tree generated from the know-how and data tables relevant to each problem. The data bases store reference information such as details of machine tools, cutting tool information, fixture details and typical cutting conditions.

Another expert system based CAPP tool is XPLANE [van't Erve & Kals (1986)]. It is able to select tools, machining operations and determine operation sequences based on a part description from a boundary representation solid modeller. An early version of XPLANE was designed purely for holes. Subsequently XPLANE was incorporated into a feature based CAPP system called PART [van Houten & van't Erve (1988)]. This system utilises both algorithmic and AI techniques. The number of available geometric features was extended to 42 [van Houten *et al.* (1989)] so that many different prismatic geometries can be constructed from these fundamental features. An expert system module is used to select tools based on geometrical and technological constraints with the objective of minimizing the number of tools required. In yet another later version [van Houten *et al.* (1990)], tool selection is also carried out by a cutting conditions module that searches a feasible parameters space that is bounded by the constraints of machine tool, cutting tool, fixtures and workpiece. Final parameters are selected based on suitable values of tool life and cutting forces. The algorithm for turning is published [van Houten (1981)] although the details of application to milling are not available. This tool selection module has been extended to integrate it with an operation sequencing function [Rho *et al.* (1992)]. Matrix methods are used to minimize the number of tool changes and to strike a balance between selecting a highly specific optimal tool for each operation on a workpiece and keeping the number of unique tools down to reduce tool change and setup times. A recent addition to the PART system is a module for calculating complex tool paths and associated cutting conditions to enable the generation of complete NC programs [Boogert *et al.* (1996)]. A new model of cutting forces for milling is used that relates the cutter and operation geometry to the various component cutting forces, based upon an extensive series of experiments. PART is apparently the first complete 'expert system' style process planning system that has been commercially exploited as it is now distributed by ICEM Technologies [de Jong & Fuchs (1994)].

A quick turnaround cell (QTC) has been developed at Purdue University [Chang *et al.* (1988)] and comprises four main functional modules:

1. A feature based design system
2. An automatic process planning system
3. A cell controller
4. A vision monitoring and inspection system

A solid modeller called TWIN is used to extract boundary information from the product model when required. Process selection and setup planning is performed by an expert system that operates on data from previous runs and from industry. Tools are classified into three groups: those already in the tool magazine, those already set up and those still in stores. The main criterion for tool selection is reducing the overall number of tools and thus, it is argued, reducing the number of tool changes, capital investment and simplifying the tool setup and storage functions. Details of the selection process for the initial set of optimal tools are not given.

Sakal and Chow (1994) use Autolisp, the internal programming and customization language of AutoCAD, to integrate AutoCAD with the popular CAM package MasterCam. This produces an automatic process planning system for 2½ dimensional prismatic parts. The main input is a three dimensional drawing in AutoCad and custom menus within the AutoCad environment allow access to the planning features. MasterCam is used to generate full NC code to machine the part. Whilst this system is able to handle most combinations of slots, steps, pockets and islands, it is limited to just 2½ dimensional prismatic parts and, as with so many CAPP systems based on CAD or solid modelling software, it suffers from a lack of tool technology data. Many systems provide very complex collision detection and tool path generation and optimization whilst almost completely disregarding the fields of tool selection and cutting data optimization.

2.2.1 Discussion

This review has shown the lack of tool selection and cutting data optimization algorithms in most process planning systems designed for milling operations. Often cutting conditions are provided by the user or extracted from data tables from tool manufacturers' documentation or machining handbooks. Geometric and material compatibility for tools is often checked although rigorous tool selection is rarely considered. A notable exception is the PART system developed at the University of Twente [van Houten (1990)] which includes cutting data optimization and a tool selection strategy (discussed in section 2.4).

Many current commercial CAPP systems have been developed from original software in the CAD field, often in the form of add-ons or customization of a central CAD system or solid modeller. Examples include SmartCam (which can interface with AutoCAD) and GNC Mill, which is a CAPP for milling add-on for the modeller GNC Solid from CadCentre Ltd. Whilst these systems can often perform impressive calculations for interference checking and tool path generation, it is noticeable that the handling of tooling technological data for cutting data calculation is often very simple. Generally there is no automated tool selection with the user being forced to select a tool before a process plan (often with accompanying NC code) can be generated. It is regrettable that little effort appears to have been expended in providing the user with multiple sets of cutting path data for a set of possible tools to assist in this important selection decision.

2.3 Cutting data optimization

Possibly due to the relatively lower complexity of tool and workpiece geometry and also the uninterrupted nature of cutting, the optimization of cutting conditions for turning has received more attention than that for milling. The available literature dealing with milling is often an extension of earlier work on turning.

Field *et al.* (1969) present detailed cost equations for milling cutters of several types: indexable carbide (and HSS) inserts, throwaway inserts, solid HSS and solid body with brazed carbide tips. An example of a face milling operation serves to demonstrate the difference between a solid HSS cutter and a throwaway insert cutter. The cutting parameters are assumed to satisfy the simple Taylor's equation and they are calculated

from three pairs of velocity and tool life data extracted by the user from recommended data sources. The objective functions used are those for minimum cost and for maximum production rate. No technological constraints are considered.

Convex mathematical programming has been used to model the technological cutting functions [Draghici & Paltinea (1974)]. The cutting cost is optimised as a function of cutting parameters such as spindle speed, feed rate, width of cut, cutter diameter and number of teeth. The model is only applicable to slab milling and includes thirteen different constraints in the cost minimization procedure. Perhaps surprisingly, the cost equation used only includes labour cost, neglecting machine tool depreciation and cutting tool costs.

Friedman and Tipnis (1976) presented the concept of cutting rate-tool life (R-T) characteristic functions for metal removal operations. This concept reduces the number of critical parameters to two - the cutting rate (metal removal rate) and the tool life. The points on the R-T curve represent the cutting conditions that produce the longest tool life for a given metal removal rate. It is shown that the solutions of the three common objective functions minimum cost, maximum production rate and maximum profit per unit time all lie on the R-T curve. In a further paper [Tipnis & Friedman (1976)], an experimental verification of the R-T curve is presented for a circular sawing operation and peripheral milling. It is shown that the R-T curve for both cases occurs in the economic working region. A method is proposed for selecting optimized conditions by finding sets of cutting parameters that lie as close to the R-T curve as possible. This can be accomplished even when limited cost data are available as the R-T curve may be constructed without reference to detailed cost data. No search strategy is presented for two independent variables. As the R-T curve can be used to find the working range of cutting parameters for a given condition it can be usefully employed for economical development of tool life data [Friedman *et al.* (1975)]. It has been further shown [Hough (1986)] that the R-T curve is only the locus of optima when the objective function is convex (for unit cost or unit time objective functions, this occurs when the tool life matrix is negative definite).

Boer *et al.* (1977) developed an adaptive control system for NC machine tools that includes two levels of cutting data optimization: off-line predictive optimization before cutting and on-line optimization which dynamically alters the cutting parameters during the cutting process in response to various power and vibration sensors on the machine. The off-line approach considers three constraints, namely tool life, surface finish and power consumption. These variables are defined as exponential products of the cutting velocity, feed and axial depth of cut. Logarithmic transformations turn the constraints into linear equations and the objective cost function into a non-linear equation which is then solved by the conjugate gradient method. The on-line optimization module generally operates by reducing the feed rate when necessary to avoid chatter.

A simplified model of cutting economics has been produced for the limited case of milling a square shoulder of given width and depth [Yellowley and Barrow (1978), Yellowley *et al.* (1978)]. The main goal of the research was to ascertain if any practical rules and guidelines could be established relating to selection of cutter diameter and cutting parameters (feed per tooth and cutting velocity). Firstly, the feed is set at the maximum allowable considering tooth breakage. This may then be reduced to satisfy the maximum torque and shank breakage constraints. Secondly, the cutting velocity is set to the value for minimum cost and then reduced if necessary to satisfy the constraint of maximum available power. This exercise was repeated for a wide range of cutter diameters and number of teeth. It was found that cutter diameter selection was of vital importance and generally it is best to select the first diameter available that is larger than the width of the square shoulder.

This analysis may be applied to any other group of tools that exhibit similar geometric features and may be largely distinguished by their diameter and number of cutting teeth. This would allow feed selection according to cutter breakage constraints as, with small diameter cutters, power will rarely constrain the feed. However, this analysis is only suitable for tools of very similar form and certain constraints, such as chatter, are not fully considered.

Metha and Singh (1980) base their method of optimization on relating the optimum tool life to other time dependent variables such as tool changing time, machining time and

non-machining time. The objective function is minimum tool wear. The tool wear rate and the tool life parameters are derived from a series of experimental tests performed with a range of cutting conditions. The constraints are the given range of tool life and the ranges of value of the independent cutting variables for which the equations for tool wear rate and tool life are valid. The optimization is achieved using the feasible direction Zoutendijk method [Zoutendijk (1959, 1960)]. This approach has some limitations as the cutting conditions are optimized to give minimum tool wear and no other process constraints are considered.

Reitz (1981) gives a brief overview of the influence that cutting variables in milling (such as cutting velocity, feed per tooth, depth of cut) have on costs and times and also suggests some strategies for the order of selection of these variables according to their influence on tool life. The common constraints that limit these variables are listed. The author's analysis of the influence of radial width of cut concludes that, for a given set of cutting parameters, the relationship between elapsed tool life and active tool life is the ratio between 2π and the swept angle. This disregards other effects of the engagement angle such as entry/exit conditions and thermal strain.

Chang *et al.* (1982) identify five important variables in peripheral milling: table traverse rate, radial width of cut, spindle speed, cutter diameter and number of cutting teeth. A series of rules are given for setting the radial width of cut from the geometry of the removed section of workpiece. As the cutter diameter can sometimes be expressed as a function of the number of teeth then the objective function is shown to contain three independent variables, namely number of pieces produced in one tool life, number of teeth and spindle speed. Of these variables, only the last is continuous rather than discrete. Although a selection of constraints are mentioned only maximum force and maximum power are considered in the given examples.

Several assumptions are made to simplify the optimization process. Axial depth is kept constant and it is assumed that the maximum possible radial depth of cut gives the most optimal conditions. It is also assumed that for a given number of teeth, the optimal cutter diameter is the minimum possible (i.e. close pitch cutters are best). This is backed up with graphs from Yellowley (1978) that, as mentioned previously, show that such

relationships can hold for certain uniform types of cutter. Tool cost is not included in the cost objective function and the number of tool variables is reduced to just two, diameter and number of teeth.

Ermer and Araj (1983) report a solution to the optimization of cutting conditions for peripheral milling using the Geometric Programming-Separable Programming (GP-SP) technique. The two cases presented are feed coupled and uncoupled with spindle speed. Tool life is considered to be a Taylor-like function of velocity, feed per tooth and radial width of cut. Five process parameters are considered: spindle speed, table traverse rate, tool diameter, number of teeth and radial width of cut. For any given tool, the solution search space is represented on a graph of spindle speed against feed rate. The major constraint curves produced on this plane are *minimum cost*, *feed limits*, *maximum power*, *maximum possible cutting force* and *surface finish limitations*. The minimum cost point is generally found at minimum spindle speed. With regard to the other process parameters, tool diameter and number of teeth, the recommendation is for the smallest workable cutter diameter with the highest number of teeth. No recommendations are given for the ideal radial width of cut. The GP-SP method is used to solve the constrained problem for two variables. Both the minimum cost and maximum production rate criteria are posynomial (all the terms are positive) and thus are suitable for the use of GP techniques. Examples are shown for several tool diameters, number of teeth, widths of cut and other constraints. The solution of the four variable problem is achieved by introducing the complete cost equation. The number of variables is reduced to three by relating the tool diameter to the number of teeth. The equations are made posynomial by using empirical approximations. The five variable problem is discussed but no solution is presented. It is observed that the results rely on empirical tool life equation constants and the need for further investigation of these values is underlined.

This paper shows yet another case where axial depth of cut is considered to be constant. This allows the problem to be reduced to two variables, spindle speed and feed rate, although examples are shown where the radial width of cut is known. The two other variables optimized are tool diameter and number of teeth although as one is expressed as a function of the other this only adds one independent variable to the problem. Given the wide range of cutter geometries now available it seems likely that such a simple

relationship is not comprehensive. As mentioned previously, this method suffers from trying to optimize tool size and geometry without considering a full range of tooling variables such as tool cost and cutting material. It is possible that a tool with a non-optimal diameter and number of teeth could perform more economically than the selected optimum tool since its other tool parameters may be more suitable. This is particularly true of large diameter cutters where close pitch geometries (large number of inserts) can be very expensive. Thus, as a tool selection method this optimization lacks creditability.

Ostafiev (1983) demonstrates an optimization method that generates cutting conditions, tool geometry parameters and a tool path with an objective function of maximum production rate. The method consists of two parts: the first defines the number of passes, the cutter diameter and the tool path, and the second calculates all the detailed milling parameters. Both parts are iterative and repeat until the maximum production rate criteria is reached. The material to be removed is assumed to be uniformly distributed to allow constant depth and width of cut. The tool path and roughing requirements are both found for minimum cutting time per part. Limiting values of cutter diameters are shown although the actual method of selection of a discrete value is not shown. The second part considers the following sets of variables:

1. The optimized variables such as spindle speed, feed rate, axial depth of cut and radial width of cut.
2. The input parameters such as material properties, machining methods, machine tool and fixture details.
3. The physical parameters such as cutting forces, contact load and surface roughness.
4. The economical output indicators such as manufacturing costs, productivity, calculated time per part and machining quality.
5. The uncontrolled disturbing factors such as changes in mechanical properties of materials and allowable variation.
6. The limits of the region of feasible values of machining parameters

The feasible region is defined by the following constraints: surface accuracy, surface roughness, maximum power, maximum cutting force, feed limits and speed limits. The method of solution is one of successive unconditional minimisation or the combined method of penalty functions. In a further paper [Ostafiev *et al.* (1984)], the method of determining the use of roughing cutters is described as being a comparison between the time required when not using a roughing cutter and the time required when using such a cutter. Tool life and force equation models are replaced with a method for determining these values from experimental data. Process parameter optimization is carried out using the Lagrange Multiplier Method. The selection of an optimum cutter diameter and geometry is achieved by searching a tools data base using the gradient method.

No cost modelling was included in this work and maximum production rate was the only objective function. The handling of the tooling parameters other than cutter diameter was not described. The use of empirical tool life and force equations could offer some advantages over using theoretical models that feature parameters defined or found in laboratory conditions as the empirical models could be found to better reflect an individual manufacturing environment. However, the force model is not comprehensive as some important parameters such as number of teeth are not considered. The use of historical data from a specific manufacturing cell is to be encouraged if prototypical systems developed in research environments are to achieve a greater degree of acceptance in real industrial situations.

Aggarwal (1985) discusses the importance of reducing machining costs particularly in light of current advances in material handling (pallet shuttle, robots and AGV's have the potential to reduce handling costs considerably). With large components, as may be found in the aerospace industry, this becomes even more important. A small diameter end mill which can machine the whole component geometry is an attractive proposition but it may require High Speed Machining (HSM) to keep down the actual cutting costs. The determination of optimized cutting conditions is carried out with diagrams of cutting power against spindle speed for various recommended depths of cut and feed rates. Constraints considered are end mill fatigue life, chip load for economical tool life, surface roughness, side force on the workpiece, spindle power and spindle speed limits. The

diagrams show the feasible regions for various types of cut. The selection procedure is as follows;

1. Select the largest diameter and shortest length cutter that can perform all the roughing and finishing operations on a part.
2. Referring to the HSM diagram for the particular end mill, select a depth of cut, spindle speed, power consumption and metal removal rate for each type of cut that is to be made.
3. Ensure that the spindle speed, power and metal removal rate are all near the available capacity of the machine.

Whilst this paper is clearly aimed at promoting the advantages of HSM in the field of substantially reducing cutting times and improving productivity, it also includes some elements of tool and parameter selection. The main tool parameter considered is stiffness which is important in the hostile environment of HSM. However, no mention is made of tool costs, geometry, depth and width capacity and cutting material. All these may affect the process constraints but, as they are not shown on the HSM diagrams, it is impossible to gauge how improvements may be made by altering the selected tool. Also many of the cutting conditions are quoted from sets of standard or typical values rather than being optimized in any way.

The relevance of reducing the contribution of machining time to manufacturing costs is stressed by Thompson (1985). The main factor controlling the cutting process is recognised as being tool life and a widely known routine for optimizing cutting data is suggested. The cutting parameters are selected in decreasing order of influence upon tool life as follows: Select the largest depth of cut possible, Select the largest feasible feed rate, Optimize the cutting velocity.

The author discusses the low level of application of cutting tool optimization technology in actual shop floor environments and suggests two main reasons for this: the lack of reliable tool life and costing data, and the requirement to manipulate large amounts of data using large and expensive mainframe computers. Of course, over the decade since this paper was written, massive computing power has become widely and cheaply

available although the first argument almost certainly still holds true. The author presents a computer program written on a microcomputer that handles turning, slab and end milling, drilling, reaming and tapping. The objective functions are limited to maximum production rate and minimum cost since, it is argued, all other objectives must form part of these two. The problems associated with obtaining tool life data are discussed. It is often difficult to find sources of consistent tool life data that covers a wide range of operations, cutter types and materials and workpiece materials and even when such data are available there is frequently a degree of disparity between data sets from different authors. Also the importance of updating a system's tool life data with real tool life data collected from the shop floor is stressed. The simple Taylor tool life equation is used for all operations except milling where an additional term describing the width of cut is added. Only two constraints are considered, these being *spindle speed and required spindle power*. This relative lack of constraints is justified by the limited ability of microcomputers to handle the additional data that would be required if more constraints were used. Finishing operations are optimized for the production of maximum surface area rather than minimum cost. The author has simplified the available machining models greatly in order to facilitate software development on a microcomputer, particularly in reducing the amount of data required. Whilst this will undoubtedly produce an increase in speed and ease of integration into real industrial environments it is likely that in the current situation of inexpensive and powerful microcomputers a more sophisticated model could be employed in a microcomputer based system.

The companies AEROSPATIALE and TOOL have collaborated on a software package for CAPP [Gouret & Maimi (1986)]. The system computes machining parameters, selects tools by rapidly comparing several available options and finally optimizes the cutting parameters. Operations covered include face and side milling, end milling, grooving, drilling and reaming. Data files contain information about tools, machines, fixtures and workpiece materials. The tool and materials data also provides all the necessary constants for calculation of force, torque and power. Details of the optimization technique and tool selection method are not given although a list of tool validation rules are presented.

Many authors have noted the greater complexity and unpredictability in dealing with milling operations when compared to the more straightforward process of turning. The nature of interrupted cutting, dynamic cutting geometries, varying chip thickness and various tool and workpiece deformation characteristics combine to present the manufacturing engineer with a process that is difficult to model satisfactorily. Lau (1987) suggests that what is needed is for the objective and constraint functions to be expressed in simple and consistent forms to allow some of the search and optimization methods originally developed for turning to be profitably employed. The method used for turning [Hinduja *et al.* (1985)] involves optimizing the objective function with respect to tangential velocity after appropriate values of the other three critical variables (depth of cut, width of cut and feed per tooth) have been set. The radial width of cut is set by the user whilst the axial depth of cut and feed per tooth are automatically selected from the a - s_z feasible region which is bounded by the minimum values of a and s_z and various other process constraints. A mesh of possible data points is created across this region and the optimized velocity is calculated for each point. The point which minimizes the objective function is chosen as the optimal parameter set. This work was extended by Arsecularatne *et al.* (1992) to include additional operations such as drilling, grooving, threading and parting off. A more advanced model of cutting forces was employed and the search process was made significantly more efficient by refining it to search just the possible solution points near the boundary of the feasible region.

The work of Lau was extended by Enparantza (1991) to provide a full tool selection capability. New constraints were added and the point search method was accelerated. The differing severity of up and down milling is considered and a vibration analysis of simple helical cutters is used to predict (and eliminate) chatter. The objective functions are operation cost or operation time. Whilst this system is admirably comprehensive, it suffers from a large number of technological constants and exponents that are not well known and must be experimentally determined. Another minor drawback is that the data base structures used to store tool, material, machine and technology data are rudimentary and few tools and machines are shown in the given examples. These limitations are common to many prototype systems developed as part of research projects and are likely to limit the applicability of the system in industry.

A method for solving the machining economics problem using graphical techniques is reported by Kirksharian and Masory (1988). The method is applied to turning, milling and grinding. Graphs of production time, cost and optimum material removal rate per unit cost are generated as functions of cutting velocity and feed rate. These graphs are constrained by maximum spindle speed, maximum feed rate, available power, critical cutting tip forces, surface finish and slenderness ratio (this relates to chip size in turning). Both an extended Taylor tool life equation and a second order logonomial equation are used to model tool life. The optimum conditions may be obtained from visual inspection of the graphs or by using the software's own searching routine. A sensitivity analysis is also available to demonstrate the influence of over forty parameters on the machining economics problem.

The optimization of process parameters by scanning a multi-dimensional bounded search space can often be hard to visualize for the researcher developing such a method or the process planner using such software. Therefore the amount of visual feedback that this system affords the user is a useful confidence booster and also serves as a secondary source of error testing as the user will be able to see if the proposed solution lies in an extreme or unexpected region of the parameter space. A slight limitation is that the selection of optimum depths of cut (both axial and radial in milling) is confined to the sensitivity analysis module.

Yellowley and Gunn (1989) present an analysis of the problem of determining the optimum radial depth of cut required for a roughing operation of a given total depth of cut without knowledge of the appropriate tool life equation when the machined volume is larger than the tool (and thus several passes are required). The operations considered were turning and peripheral milling. The three constraints used were tool edge breakage, power/torque limits and chatter onset. The chatter constraint was expressed as a maximum width of cut, b_{max} , allowable for a given axial depth of cut. If this limiting value is greater than the tool diameter, D , then $b_{max}=D$. There is also a critical width of cut, b_{crit} , above which the constraints other than tool breakage become active. The optimization strategy consists of selecting the highest feed per tooth allowable considering tool breakage for a given radial width of cut. Cutting velocity is optimized

for this value and, if the torque constraint is active, the feed per tooth is then reduced to satisfy it if necessary. Similarly, if the maximum power constraint is active then the feed per tooth is kept static and the tangential velocity is reduced to satisfy it. It is demonstrated that there are only two strategies that will lead to minimum cost in the following two situations:

1. $b_{crit} < b_{even}$ Minimum cost is achieved by either taking:
 - (a) one pass at b_{crit} and the rest at equal depths
 - OR
 - (b) all passes but one at b_{max}
2. $b_{crit} > b_{even}$ Minimum cost is achieved by either taking:
 - (a) all passes but one at b_{crit}
 - OR
 - (b) all passes but one at b_{max}

where b_{even} is the width of cut for uniform radial width of cut distribution.

The authors note that whilst it would be helpful to introduce the maximum radial width of cut for chatter as a constraint, this is not possible as the width of cut influences the magnitude and direction of the resultant cutting force and also the frequencies of the milling force are dependent on the cutter diameter and number of teeth.

The formulation of objective functions is often reduced to the three most common performance indicators production rate, machining cost or machining time. Agapiou (1992a) proposes a new form of objective function that combines product cost and machining time. This combined objective function is of the form:

$$v(v, f, d) = w_1 C_u + w_2 \lambda T_u \quad (2.1)$$

where v is the objective function, v is the cutting velocity (m/min), f is the feed rate (mm/rev), d is the increment of the depth of cut (mm), w_1 and w_2 are weight coefficients, C_u is the production cost (\$/piece), λ is the constant multiplier and T_u is the total production time (min).

The production time is normalized with regard to production cost by using a constant multiplier, λ , which is given by:

$$\lambda = \frac{C_{u_{min}}}{T_{u_{min}}} \quad (2.2)$$

The weight coefficients can be used to bias the objective function towards one or other of the base functions. The constant multiplier, λ , is dependent on depth of cut and can be calculated by obtaining the optimal values of cutting speed for minimum production cost and for minimum production time. As the objective function is reduced to just two variables it is possible to show objective contours on a cutting-speed vs. feed rate plane. If the major constraints are also mapped onto this plane it is possible to visually select an optimum set of cutting data. This approach is designed for simple single-pass operations but it has been extended for multi-pass operations [Agapiou (1992b)] by incorporating a method for optimization of the number of passes using the dynamic programming technique. Each pass is then considered in the previously described way.

The concept of forming a compound objective function by summing weighted normalized performance indicators could also be useful for the sorting of potential tools in a tool selection system.

A similar technique is proposed by Jha (1990). The objective function is a weighted combination of cost per piece and rate of production. All the constraint and objective functions are linearized and solved using a modified geometric programming method. An example is used to demonstrate that this technique is particularly useful for situations where speed and feed are only available at discrete values.

Kiliç, Cogun and Sen (1993) present a method for mapping all the relevant constraints and a number of objective function contours in the cutting speed vs. feed rate plane. The user can visually inspect such a graph and determine the optimal position for the active objective function (either production time or production cost in the examples given)

within the feasible area. The power of a human observer to be able to process a search space graphically is not to be underestimated and this technique eliminates the need for complex searching algorithms. However, certain simplifications must be made in order to map all the constraints and contours onto the V - s plane and, of course, extensive user interaction is required, making this unsuitable for automatic operation or tool selection where many sets of optimized cutting data are required for a set of feasible tools.

2.3.1 Discussion

The cutting conditions optimization problem for milling is highly complex and features many independent and dependent variables. The most complete mathematical models include many constants and coefficients that are not readily available or only to be found from extensive experimentation. Thus, much of the reviewed research features some simplification so that at least one of the main process variables may be held constant whilst the others are optimized according to a given objective function, often minimum cost or maximum production rate. When a large selection of variables is considered, it is often necessary to simplify the formulation of the model to allow mathematical programming techniques to be applied. One of the hardest constraints to successfully apply is the onset of chatter due to various difficulties in formulation as mentioned by Yellowley and Gunn (1989). It seems clear that future systems should include as much tool, machine, workpiece and material information as available and that as many constraints as can be achieved should be considered. However, it is worth remembering that in such a multivariate problem, which includes inherently unpredictable elements such as tool life, it is unlikely that single highly specific optimal conditions exist or, if they do, the task of iterating towards the optimum may become overly complex or laborious.

2.4 Tool Selection

Tool selection forms one essential part of any true process planning system. An automatic tool selection system must attempt to select feasible tools to achieve a given manufacturing feature or objective which may include several different material removal operations. This process should feature an element of optimization to demonstrate that the selected tool is the most suitable available. Ideally, such a system should be able to run without user intervention although it is often desirable to permit an element of

customization so that the user may influence the selection criteria and optimization method.

The selection of tools is of critical importance to the overall costs of an operation as not only do tools vary in price themselves but also the geometric and material properties of a tool define the range of suitable cutting conditions. Given the advantageous effects that successful tool selection can have in terms of refined cutting action and reduced costs, it is perhaps surprising to see the relative scarcity of published literature on the subject. Whilst tool selection is often mentioned when describing process planning systems there is little detailed information about the procedures available. Also much of the available tool selection work has been for turning tools although many of the principles applied may be useful for milling tools also.

Tool selection procedures can be found in many tool manufacturers' catalogues [Seco Tools AB (1993), (1994)]. As these instructions have to be applicable to a wide selection of manufacturing situations the method is highly simplified and provides conservative cutting parameters. There is little information regarding selecting the exact cutter type for a given operation (this is particularly notable for some common operations, such as facing, for which most tool vendors offer a large number of possible cutters).

Giusti *et al.* (1986) present an expert system, called COATS, for optimized tool selection for turning operations. It forms part of a larger generative process planning system called PICAP. The technological structure of the manufacturing system is stored in a system of rules and the suitability of individual tools is assessed by assigning weights to each rule in the knowledge base. As the authors note, the assigning of arbitrary weights is not only a function of the importance of the particular parameter but also of the user's knowledge and experience. It has been argued [Maropoulos (1988)] that the weight given to a parameter is also a function of the operation being considered. For instance, in face milling the machine power can constrain the axial depth and feed rate and thus a smaller diameter tool might be capable of producing a higher metal removal rate than a larger diameter cutter. The workpiece shape may also influence the ideal tool geometry. However, if the active constraint is tool stability (onset of chatter) then a stiffer tool (i.e.

larger diameter) will be preferred. There are many characteristics that influence what constraints become active and this weighting method ignores some of them such as machine power response and workpiece geometry.

The Production Rule Matrix Method (PRMM) has been applied to the selection of tool class and tool holder, two stages in process planning that often require experience or data of a heuristic nature [Domazet (1990)]. It is claimed that this technique offers advantages of speed and efficiency over conventional rule based AI languages. Weighting coefficients are used for tool selection and cutting data evaluation is based on manufacturers' standard cutting data tables rather than analysis of the cutting process.

van Houten (1986) presents a comprehensive discussion of the requirements for process planning of roughing turning operations. A new method of roughing tool selection is presented based upon dynamic programming techniques. An initial superset of feasible tools that can machine the required operations is constructed and the optimal set of tools is found by relating the total costs linked to each tool to the number of available tool turret positions. An analysis of the frequency of use of various types of tool also contributes towards finding the basic set of feasible tools for each specific machine tool. Tools may be then selected from this reduced set or from the whole tool store depending upon batch size. The aim of the system is to produce reasonable tool selections which will operate reliably rather than produce highly optimized aggressive cutting data and thus the objective function is just a rough cost estimate rather than a more complex economic model. Also the number of constraints considered is limited to a few important ones. The author claims that the effect of reducing the overall set of tools available to the workshop will reduce the amount of capital investment and tool management costs. However, it seems that modern tool management technology is capable of handling a large diversity of tools and the use of predefined tool sets is incompatible with the use and maintenance of a comprehensive tool data base. Reduction of variety of available tools could eventually lead to reduction in versatility and applicability. However, the small number of tool turret positions available on many lathes does suggest that a degree of rationalization of tools for a set of operations is desirable to reduce tool setup and change costs.

Mathieu and Bourdet (1987) propose a tool selection method for turning based upon matching definition parameters of the operation with tool characteristic parameters of a geometric and technological nature. Cutting conditions are identified using linear programming. The system is limited to cylindrical turning.

Melkote and Taylor (1988) report an expert system for selection of milling cutters and determination of optimized feed rate and spindle speed. Typically, required information includes a geometric description of the workpiece, the workpiece material and the operation details. These data are used to generate the desired tool characteristics such as cutter type, critical rake angles, diameter, pitch and insert shape. Having selected a tool from a database of available tools, the cutting conditions are determined using objective functions such as operation cost and production rate whilst constraining the solution by cutting force, tool rigidity, surface finish and machine power.

The selection of the cutter is based upon a set of rules applied to the seven parameters listed previously. Whilst these rules may be designed to lead to safe and feasible cutting conditions they do not necessarily lead to an optimum. For instance the selection of cutter diameter is based only upon tool stiffness and surface finish, leading to a preference for the largest diameter possible. Similarly the selection of cutter pitch does not correspond with evidence published elsewhere [Yellowley & Barrow (1978), Chang *et al.* (1982)] where the greatest available pitch is the preferred choice. The effects of cutter diameter and pitch on metal removal rate are disregarded by Melkote and Taylor in favour of providing adequate chip clearance space and preventing chatter. This example illustrates the difficulty in assigning 'weights' to machining parameters as these weighting values will depend upon what constraints are active on the machining process at any one time. If chatter or chip capacity constrain the process then a decrease in cutter pitch (i.e. closer pitch) will reduce the machining performance. However, if these constraints are not active then this will have an advantageous effect on the operation by increasing the possible metal removal rate. The only way to determine which constraints are active is to perform as complete an analysis of the machining process as possible. The operation dimensions are input by the user and the cutting conditions are optimized in a

conventional manner. The feed rate is fixed as high as the constraints will allow, the spindle speed is obtained by minimizing the cost or time equations in relation to cutting velocity. The tool life equation used includes cutting velocity but not feed rate or axial depth of cut. The authors stress the desirability of achieving an effective interface to a CAD system to simplify the input of geometric information, although this remains a substantial task in its own right.

Chen *et al.* (1989) use an analysis of the cost equation to demonstrate that, for any given tool and workpiece material, the only tool parameter that affects the operation cost is the cost per cutting edge. The authors' method for tool selection relies upon ranking a list of feasible tools by this parameter and only carrying out detailed cost and cutting conditions calculations on the top tool in the list (with the smallest cost per cutting edge). The other tools in the list are first examined to determine if their parameters will alter the constraint curves. A tool with a higher cutting edge cost may still satisfy the constraints and therefore be worthy of a full calculation of costs and cutting conditions. All the other tools which would not lead to higher cutting parameters are disregarded without further analysis. The given examples are for just one combination of tool material and workpiece material and thus the coefficients, exponents and constants that depend on this combination are not considered.

This reduction of tool parameters to just one is fraught with difficulties for several reasons. The objective function is affected by more than one tool parameter and the relative importance of each parameter varies with cutting velocity. Also the only tool parameter that can be separated from the full set of cutting variables is the optimum velocity.

The aforementioned generative CAPP system called PART has been developed at Twente University and features a tool selection function [van Houten *et al.* (1990)]. An initial list of feasible tools for a setup is generated by tool type and geometric limits. The objective function is either minimum number of tools or selection of the most appropriate tool for each machining operation. Tools are selected according to their performance generated by the cutting conditions module. For roughing, various criteria are considered including metal removal rate, maximum allowable loads and exit conditions for up-

milling. This latter constraint suggests that some knowledge of the tool path is generated for each tool, although a complete tool path analysis for every possible tool could be too lengthy and complex a procedure to be useful. For finishing, tool deflection and dimensions are considered although the method for determining finishing passes is not given.

Fenton and Gagnon (1993) report a computer based method for cutting tool material selection based on multi-objective optimization using numerical techniques. Various degrees of tool life utilization (always between 0 and 1 in value) are plotted as curves on the graph of total production cost (\$/part) against total production time (min/part). Several other constraint functions are plotted on the same plane including a range of lines representing constant profit rate. The user visually selects points in the feasible region that satisfy all the constraints and correspond to the highest profit rate available. This procedure is repeated for all the candidate tool material grades and, by comparing the optimal points thus obtained, the most suitable tool material is selected. Additional mapping methods and adjustments to allow for machining an integer number of parts with one tool and dealing with machine tools that only possess a discrete number of spindle speeds are presented. The method outlined is completely manual and requires a considerable effort in manipulating tool and technology data and plotting graphs. As the authors note, the method lends itself to software implementation although it is not clear what method could be used to automatically search the feasible region and select possible optimal points.

Maropoulos and Hinduja (1990, 1991) present a refined and comprehensive method of tool selection for roughing and finishing turning operations developed at UMIST, Manchester. The finishing method uses the 'effective unit cost' (e.u.c.) for every tool that can machine a given feature. The e.u.c. is the cost per unit of machined length and forms a stable and objective basis for comparing the performance of tools. Tools are ranked by e.u.c. and the user may make the final selection. Unlike most of the systems mentioned in this section, the UMIST method includes 'feature splitting' - the ability to machine a feature using more than one tool (e.g. a recess may be turned with a right handed tool for one side and a left handed tool for the other edge). The method is

implemented in a software package called Automatic Tool Selection (ATS) which forms part of the larger process planning system for turning called TECHTURN.

A companion module in TECHTURN is the Semi-Intelligent Tool Selection System called SITS [Hinduja & Barrow (1993)]. This presents a cutting data optimization process similar to that of ATS but the user is afforded a large amount of flexibility in which tool is finally selected from a list of feasible tools and cutting conditions. The system displays the tool that is calculated to be optimal and the user may progressively move away from this tool by altering various properties of the tool to move to other tools in the feasible tool list. As the selected tool is changed, the penalty (or bonus) in terms of cost and performance is shown.

Recently, a tool selection system for milling called EX-CATSMILL has been developed at the University of Sheffield [Razfar & Ridgway (1994a), (1994b)]. The system features a rule based method for tool selection and a mathematical process model for optimization of cutting conditions. The tool selection rules have been elicited from technical catalogues, books and domain experts. Constraints included in this rule base are tolerance of geometric features, surface finish, workpiece material and machine tool characteristics. Machining operations are represented by codes of eight characters which represent the material, setup number and co-ordinates of the start and end points. Other selection criteria include insert tolerance, insert shape, chip space and the cutter rake angles. Cutting data is optimized for minimum production cost or maximum production rate. If the power constraint is exceeded, the feed rate is progressively reduced until the constraint is satisfied. It appears that optimized cutting conditions are calculated for just one tool per operation. An example component with one facing operation and two square shoulder operations is presented along with the optimized cutting data for each, although the actual tool specification is not given. EX-CATSMILL presents an interesting combination of flexible rule based logic for tool selection and rigorous mathematical modelling for cutting data optimization.

Research at the University of Durham has resulted in a new semigenerative process planning system for turning [Maropoulos & Gill (1995)]. Much use is made of cutting

data that has been 'approved' on the shop floor and is thus regarded as feasible and proven for a specific manufacturing environment. Complex pattern matching criteria are used to match a new machining operation with a similar previously performed operation stored in the approved database. The similarity criteria are based on metal cutting theory and practical engineering knowledge and incorporate considerations in relation to the component and cutting profile geometry, material type and operation type as well as tool and insert characteristics. For any similar approved operations, the corresponding tool and cutting data are retrieved and sorted in order of preference. Based on the level of similarity the retrieved information is either presented as it is or automatically modified to better suit the new operation. A large set of experimental trials verified that the system produces feasible cutting data that works first time in the large majority of cases [Maropoulos & Alamin (1995)]. This work illustrates a useful concept for designing CAPP systems - entering proven data from the shop floor back into the system to form a feedback loop. Statistical techniques may be used to analyse the difference between the system output and the final approved data to generate relationships that can be used to alter the output of the system to conform to specific local conditions in the future. This 'closed loop' model presents several advantages over the traditional deterministic 'open loop' architecture: the output of the system can reflect subtle changes in the manufacturing environment, such as machine tool wear, and constraints that are difficult to model, such as machine tool stability, which can severely limit the suggested data.

Many tool selection systems perform exhaustive analysis on individual tools related to one specific operation. Whilst this can lead to highly optimized tool sets it will also tend to produce tool sets with a large number of unique tools that happen to be the optimal tool for a particular operation. Most modern machine tools have tool turrets or carousels that will hold a limited number of pre-set tools so it is advantageous to keep the number of unique tools required to less than the number of available tool posts so as to reduce the tool setup requirement. Zhang and Hinduja (1995) propose a method for determining the optimum tool set for a given batch of turned components. The optimization criteria are either minimum machining time or minimum number of machine stoppages (or a combination of both). An optimized list of candidate tools with associated cutting and cost data is produced for each operation and these are formed into a tool-operation-cost

table. This table is exhaustively searched to find the optimal set of tools. The wear rate of each tool is adjusted so that it machines an integral number of components and further adjustments are available to force tool changes to be synchronized. The optimization method considers many factors including the number of turret positions, the batch size and the performance of all the possible tools.

This paper presents a comprehensive approach to the generation of an optimized set of tools for a group of operations performed on a batch of components. As might be expected, for small batch sizes a significant reduction in production cost can be achieved by selecting tools for the whole batch rather than by optimizing the tooling for each operation. With larger batch sizes, it is more likely that the optimized tools selected for each operation will form part of the optimum tool set for the whole component. A possible weakness of this approach is that it assumes a comprehensive knowledge of the tool wear characteristics of all the tools considered and many of the possible reductions of production cost and machine stoppages will only be achievable if the tools wear in a highly predictable manner. Many authors have reported the large amount of scatter that can be found in experimental tool wear measurements and to enable precise tool wear balancing may require a significant margin of safety on tool life calculations in order to reduce the possibility of random tool failure.

2.4.1 Discussion

As has been mentioned in the introduction to this section, there is relatively little published material regarding tool selection for milling. Although much may be learned from the available literature on tool selection for turning, there are a host of additional physical and technological characteristics that further complicate the task of selecting multi-tooth, rotating tools to be used on three dimensional workpiece geometries. Perhaps partly due to this abundance of available variables, many authors reach different conclusions about the application of certain tool parameters and constraint functions. Often this is due to the fact that analyses are restricted to certain classes of operations. Alternatively it appears that some authors simply have different opinions about what factors are important and what actually constitutes safe and consistent cutting. Many prototype systems rely on obscure constants that are only obtainable through series of experimental tests and this limits their applicability in industrial environments. Any future

tool selection system should incorporate as much tool and workpiece data as is freely available, particularly with regard to tool and workpiece material. Complete catalogues of tools and all material standards are easy to obtain and current microcomputer-based database management technology is mature enough to deal with large data tables (typically up to one billion records on a standard PC). The user must be allowed to intervene and influence the criteria used for tool selection although the system should be capable of running automatically if required. Finally the system should be able to demonstrate how the optimal tool was selected and permit the user to select a sub-optimal tool whilst being informed of the cost and time penalties incurred.

2.5 Machinability evaluation

Much research work has focused on analysing the differences in machining performance between engineering materials [Mills & Redford (1983)]. Often this work has focused on experimental cutting tests allied with microscopic examination of the material to evaluate the modes of tool wear and the characteristic cutting action. Machinability tests fall into two main categories: those that require a metal cutting operation to take place and those that do not. In addition these may be further divided into two more categories: those that merely define, for a given set of conditions, the relative machinability of two or more tool material/workpiece material combinations (called *ranking tests*) and those tests that indicate the relative machinability of two or more work-tool combinations for a range of conditions (called *absolute tests*). The results of a ranking test, whilst being useful for discarding certain unsuitable workpiece-tool combinations, suffers from two main disadvantages. Firstly although the test may reveal that material A is easier to machine than material B it is difficult to quantify the difference as, for one set of conditions, the measure of machinability is unlikely to exhibit a simple correlation with the main working parameters such as tool wear. Secondly there is no guarantee that the ranking order will not change as the conditions are varied. An absolute test can indicate variation in machinability across a range of cutting speeds and possibly across a range of other cutting conditions and tool geometries. In practice a non-machining test must be of the ranking type and a machining test can be either ranking or absolute.

When considering the assessment of machinability within the framework of a tool manufacturer providing tooling support it becomes clear that machinability evaluation requiring machining tests is impractical. Machining tests require considerable resources of time and labour for preparing a suitable test suite of conditions and closely observing the machining performance produced. Perhaps even more importantly, a significant amount of workpiece material is required. Many small batch or jobbing shops will receive just the rough workpieces with no spare material available for testing. Also the workpiece material may be expensive or difficult to obtain. Thus for real time machinability evaluation, implemented in software, it is most appropriate to use a non-machining testing method.

Non-machining tests fall into three main types:

1. Chemical composition tests
2. Microstructure tests
3. Physical properties tests

Each type of test requires different types of input data and has different ranges of applicability.



2.5.1 Chemical composition tests

Many tests have been performed where the results of a ranking test of some form are correlated with the major chemical constituents of the material. Most authors acknowledge that these tests are most suitable for materials of the same type and thermal conditioning. However, they can be a useful aid to screening materials and tools if the limitations of the particular method are appreciated.

Czaplicki (1962) investigated the relationship between the cutting velocity for a tool life of 60 minutes (v_{60}) and the material composition, resulting in the following equation:

$$v_{60} = 161.5 - 141.4C - 42.4Si - 39.2Mn - 179.4P + 121.4S \quad (2.3)$$

This equation was reported to apply for steels and produce results within 8% of those obtained from machining tests.

Boulger *et al.* (1951) formulated a machinability index for a range of free-machining steels. It was expressed in terms of chemical composition as:

$$\text{Machinability index} = 146 - 400C - 15000Si + 200S \quad (2.4)$$

Similarly, Mills (1980) has demonstrated the significant influence of residual elements on the v_{240} cutting speed for leaded free-machining steels. It was shown that increasing the amount of residual elements raises the strength of the ferrite which can consequently increase the wear rate of the specified M2 high speed steel tools.

Relatively little recent research has addressed the problem of relating chemical composition to machinability. This is perhaps partly due to the limited range of applicability of some such relationships and also the ever increasing range of available engineering materials makes it difficult to expand this range of applicability without extensive experimentation.

2.5.2 Microstructure tests

The microscopic structure of a material can provide useful clues as to how easily it can be machined. Some of the early work on low and medium carbon steels concluded that uniformly distributed pearlite with large interlaminar spacing was the optimum microstructure for milling and turning [Whittman (1945), Woldman (1947), Robbins & Lawless (1955)].

One of the more comprehensive evaluations of the effect of microstructure on machinability was carried out by Zlatin and Field (1950). A summary of their results can be seen in Table 2.1. They concluded that steels which contain more than 50% pearlite exhibit favourable machining characteristics and high bulk hardness.

Type of microstructure	Brinell hardness	v_{20} cutting speed (m/min) (carbide tool)	Machinability rating	
			Relative life at constant speed (min)	Relative speed at constant tool life (m/min)
10% Pearlite + 90% Ferrite	100-120	290	8	22
20% Pearlite + 80% Ferrite	120-140	260	6	20
25% Pearlite	150	-	-	15
Spheroidised	160-180	180	5	14
50% Pearlite + 50% Ferrite	150-180	-	4	11
50% Fine pearlite + 90% Network ferrite	202	-	-	10
75% Pearlite + 25% Ferrite	170-190	140	3	11
100% Pearlite	180-220	145	2	11
Tempered martensite	240	-	-	8
Tempered martensite	280-320	105	1	8
Tempered martensite	350	-	-	6
Tempered martensite	370-420	46	0.2	3

Table 2.1: Effect of microstructure on machinability of steels

More recent work has focused on the effect of minor elements on machinability and in particular the effect of manganese and sulphur, in the form of manganese sulphide inclusions, in free machining steels. It has been shown that whilst the amounts of manganese and sulphur are important, the size and distribution of the manganese sulphide inclusions can also significantly affect machinability [Chisholm & Richardson (1965)].

Theoretically an examination of microstructure should give a better measurement of the machinability of a material than considering only chemical composition. However, this type of test has two main problems associated with it. Firstly, it is difficult to measure the relative constituents of a material quickly and even when this is possible the rankings tend to be based on subjective measures such as good, medium or bad. Secondly, the staff and equipment required for such microstructure tests will not always be available to those companies that could best make use of the information.

2.5.3 Physical properties tests

Often physical properties are quicker and easier to measure than chemical composition or microstructure. The search for simple criterion for assessing machinability based on physical properties led Henkin & Datsko (1963) to develop a general machinability equation using dimensional analysis. This equation is stated as:

$$v_{60} \propto \frac{B}{LH_B} \left(1 - \frac{A_r}{100}\right)^{\frac{1}{2}} \quad (2.5)$$

where B is the thermal conductivity of the material, L is a characteristic length (mm), H_B is the Brinell hardness of the material and A_r is the percentage reduction in area from a standard tensile test.

This was shown to produce a good correlation for a small number of chosen steels. Similar work by Janitzky (1944) produced the expression:

$$v_{60} \propto \frac{D}{H_B A_r} \quad (2.6)$$

where D is a constant dependent on the size of cut. Again a good correlation between the predicted and the experimental cutting velocity was found to exist. As with the microstructure tests described in the previous section, a certain level of equipment and staff are required for physical properties tests but, if these are available, it may be possible to determine machinability factors to an acceptable accuracy.

2.5.4 Machinability databases

There exists a large amount of proven machinability data in machining handbooks [Metcut Research Associates (1980)], tool manufacturers' catalogues and documentation [Seco Tools AB (1993),(1994)] and in old industrial process plans. Despite these rich sources of historical data, there is a paucity of published work in the field of analysis of machining data sources with regard to better prediction of machinability characteristics of future jobs and new materials.

One of the few areas where large amounts of machinability data are used is material selection. During the design process it is necessary to select materials using many varied criteria including strength, toughness, aesthetics and cost. Machinability can also be an important factor as considerable savings can be made from an optimized and efficient cutting process. Jin and Sandström (1994a, 1994b) propose a system for consistent assessment of machinability across a wide range of materials. The method produces two machining properties at different levels of precision: nominal machinability rating and chip characteristic level. The first property gives the relative rate of material removal in turning, milling and drilling operations and the second describes the chip breaking and surface finish characteristics. Materials are categorized into six material groups: Carbon Steels, Alloy Steels, Stainless Steels, Copper Alloys, Aluminium Alloys and Magnesium Alloys. Each group contains sub-groups that are related by composition and mechanical properties. Machining data are taken from the *Machining Data Handbook* [Metcut Research Associates (1980)].

The nominal machinability rating is given by the percentage ratio of the typical metal removal rate achievable for a given material with the rate achieved with a standard reference material. For carbon steels, alloy steels and martensitic and precipitation hardening stainless steels a correlation between material hardness and the machinability rating is shown. This is exploited by applying multiple regression to graphs of machinability rating against surface hardness. Thus it becomes possible to interpolate a value of machinability rating for a material of known surface hardness. For aluminium, copper, magnesium alloys and austenitic and duplex stainless steels it is shown that the temper condition is related to the machinability rating.

The second proposed machinability property, chip characteristic rating, consists of a rating from 2 to 7 (in increasing order of merit) that characterizes the chip formation for aluminium alloys. The correlation between various additives and quality of chip formation is discussed.

Whilst this method can provide a useful method of rating a proposed material on a machinability basis, at the design stage, it does suffer from several points of weakness. Although the nominal machinability rating for some material types is calculated in a

mathematically continuous and rigorous way, for other material types it is assessed for an input parameter with discrete values (surface conditions) that is liable to a degree of subjectivity. Similarly the chip characteristic rating is a subjective measure of the quality of chipping achieved. It may be possible that chipping of an undesirable form could still lead to satisfactory material removal and tool wear conditions. It is claimed that the machinability ratings are presented in such a manner as to be directly comparable between different types of materials. In light of the aforementioned differences in evaluation method this seems to be difficult to justify. It is interesting to note that, as this method is intended to assist designers at the conceptual design stage, the details of actual cutting parameters are hidden by combining them together into the material removal rate. The fact that surface hardness may have quite different effects on the feeds, speeds and depths for various groups of materials is obscured by this simplification. Possibly the most critical limitation of the method of Jin and Sandström is that there are no suggestions as to how a new material might be fitted into one of the suggested 46 material groups. Despite these limitations, the use of multiple regression on large tables of cutting data to establish the machining characteristics of a material is a valuable approach that has been pursued in the research described in this thesis.

Yeo, Rahman and Wong (1989) present an investigation of various multiple regression model-building techniques applied to machinability data in order to study the suitability of the empirical equations often used for machining calculations. A commercial statistical package called SAS is used for the regression analyses. The criterion of model building in regression is *parsimony*, that is, to develop the multiple regression model which includes the fewest number of (independent) variables that permits an adequate interpretation of the responses. The R^2 procedure is used to examine all possible combinations of the available independent variables and produce optimal subsets of variables. Using a test data set, the analysis showed that for tool life and surface roughness there is no outright best equation although the R^2 method does suggest that the four parameter first order model (like the extended Taylor equation) would provide the best choice. The authors stress that a modular rapid analysis tool such as SAS could form part of a manufacturing planning system. Verified cutting data from the shop floor can be added to the data tables and updated equations can be generated in real time, thus

providing an enhanced representation of the actual production process. As constantly updated equations are widely regarded as desirable, it is unfortunate that this method has not found any application within a actual process planning system. The search for an optimized set of input variables is a useful exercise although, as the authors state, it did not provide any significant gains over the conventional full-form single order equations for tool life and surface roughness.

2.5.5 Discussion

Much research effort has gone into studying the mechanisms that effect machinability at a microscopic level. The examination of chemical composition, microstructure or physical properties can be highly labour intensive and will often only concentrate on just one workpiece material. These studies may also take a significant amount of time that is unlikely to be available in a busy metal cutting shop. It is perhaps of more use to an industrial process planner to think of machinability as being well defined by the optimized stable cutting conditions that can be used for a given material. The level of difficulty of machining should be reflected by the rate of material removal and therefore the cutting conditions. Little published research concentrates on methods of manipulating large bodies of machining parameter data in order to assist in the prediction of machinability of new workpieces. However, if a comprehensive data base can be built then there are many possibilities for analysing trends within the data using techniques such as knowledge-based reasoning and regression.

2.6 Summary and conclusions

Machining research has been progressing throughout the twentieth century from the early seminal work by F.W. Taylor (1907) right up to the latest computer based systems. However, this research effort has become fragmented [Maropoulos (1995a)] and the rate of uptake of methods and systems to enhance the cutting process has generally been disappointing. The development of graphical systems to manipulate component geometries and generate complex tool paths has enjoyed a relatively high profile but interfaces are required to robust tool selection and cutting data optimization systems if process planning is to become truly '*computer aided*'. Many authors have recognised the reduction in the level of machining know-how amongst tooling users and there has been a concerted attempt to capture some of this rapidly dwindling experience in knowledge-

based systems and other non-deterministic software structures. Possibly the approach most likely to succeed would be a combination of a formalization of this encapsulated expert knowledge and a rigorous mathematical machining model. Rule bases are well suited to tasks that benefit from experience such as cutter geometry selection and material categorization. However, the interplay of the cutting variables in the actual machining process is too complex to formalize in a rule based structure. Fortunately, many mathematical models have been shown to successfully predict machining performance and optimize the rate of material removal which is, after all, an important element of modern process planning.

Despite the many decades of published research regarding the planning and management of metal cutting processes there still remains some gaps in the progress towards fully integrated CAD/CAM. Much research has led to the development of prototype CAPP systems that incorporate small numbers of tool geometries, cutting materials, workpiece materials and machining operations. However, in the jobbing shop/small batch production environment the level of product variety can be high and thus the range of tools and materials data required can be extensive.

The current widespread interest in concurrent engineering techniques has created a demand for process planning information much earlier in the product life cycle than previously. The amount of detailed product information available at these early stages is likely to be very low and thus there is a requirement for flexible cutting data generation from a coarse or partially defined workpiece description. Later on, in the detailed design stage of product development, a complete range of workpiece information will generally be available and, in this case, a modern CAPP system should be able to automatically select tools and provide associated optimized cutting data, driven by the user's optimization criteria.

Most published research on cutting data evaluation concentrates on single tools for individual machining operations. However, industrially applicable CAPP must be able to handle the generation of process plans for sets of operations on one or more component and consider limitations of tool inventory and automatic tool changing capacity on

modern machining centres. It is often desirable to optimize cutting data and tool selection for *sets* of tools, as well as for single cutting operations considered in isolation.

Many aspects of the machining process are very difficult to model, such as tool stability and wear, and require considerable laboratory testing or expensive real-time sensing equipment to measure or predict. On the other hand, the experience possessed by machine operators and contained in old process plans can be a valuable resource when attempting to take some of these machining characteristics into account. Few academic or commercial CAPP systems accept the cutting data that is *approved* by successful usage on the shop floor as a further source of knowledge for refining the performance of generative or semigenerative CAPP. Although the collection and verification of such data is a substantial task, this feedback of historical data could offer a valuable advance in reliability and applicability with which to encourage the industrial exploitation of research based CAPP methods.

Chapter 3

OPTIMUM - overall system description

As described in the conclusion of the preceding chapter, there are some gaps in current CAPP research when considered against the requirements of a modern manufacturing facility. The CAPP decision support system developed as part of this research, called OPTIMUM (Optimized Planning of Tooling and Machinability evaluation for Milling), is designed to address some of these limitations. The specific context of the implementation goals is to produce a tool selection and cutting data calculation package that would be useful for assisting a tool manufacturer in providing off-line technical tool support to customers. The research objectives behind the OPTIMUM system are, however, rather broader in scope and include functionality that is associated with CAPP systems employed in individual manufacturing facilities. This chapter presents an overall description of the system and describes some of the supporting functions that are required in order to integrate a range of process planning functions, such as user interface design philosophy and workpiece geometry handling.

3.1 Introduction

Throughout this thesis, the OPTIMUM system is described by means of Data Flow Diagrams conforming to the Structured Systems Analysis and Design Method (SSADM), a software specification method used by the British Government since the early 1980's.

At the highest level of abstraction, Figure 3.1 shows the OPTIMUM system placed within the context of other co-operating external functions such as the process planner, the scheduling system, the tool stores and the shop floor.

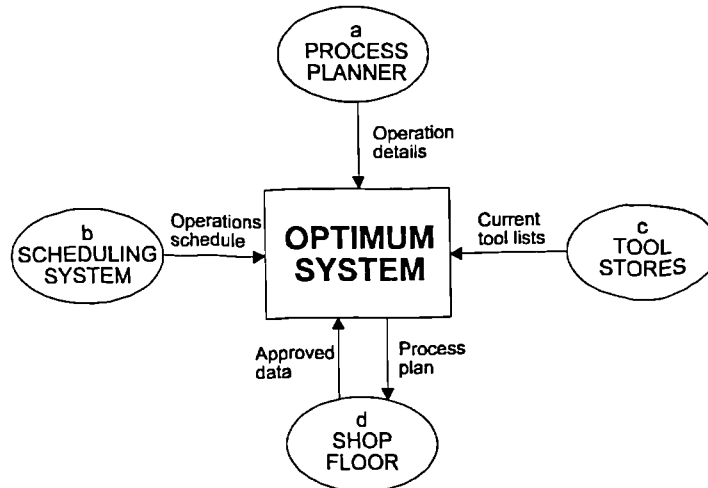

Figure 3.1: Context diagram of the OPTIMUM CAPP system

OPTIMUM is designed to be an advisory service rather than a prescriptive automated CAPP system and as such, it generates data in a human readable form. There is no post-processing to produce machine readable output (such as NC code) for two reasons. Firstly, many such post processors already exist (usually as part of CAM systems) and part of the novelty of the OPTIMUM system lies in how it interacts with the human user rather than in employing machine tools in a new or different way. Secondly, a numerically controlled milling machine was not available within the period of this research, making direct testing of NC code unviable.

3.2 Functional description

The OPTIMUM Computer-Aided Process Planning system is designed to provide several functions to assist a process planner, production engineer or tooling support engineer. These functions include:

1. Straightforward geometry input for machining operations.
2. A flexible workpiece material description method including automatic material classification from incomplete data.

3. Machinability assessment to produce initial cutting data for a wide range of input data.
4. Optimized calculation of cutting data.
5. Rapid tool selection by applying user defined criteria.
6. Tool variety reduction to produce tool sets of limited size.
7. Feedback of approved data from shop floor into the system to enhance data accuracy in the future.
8. Robust data driven software design to facilitate maximum flexibility of operation.

Many of these functions are implemented in separate software modules that can be executed individually. However, the best results can be obtained when running the whole set of modules as many of the modules produce data that can be acted upon by other modules. The overall functional layout is shown in Figure 3.2.

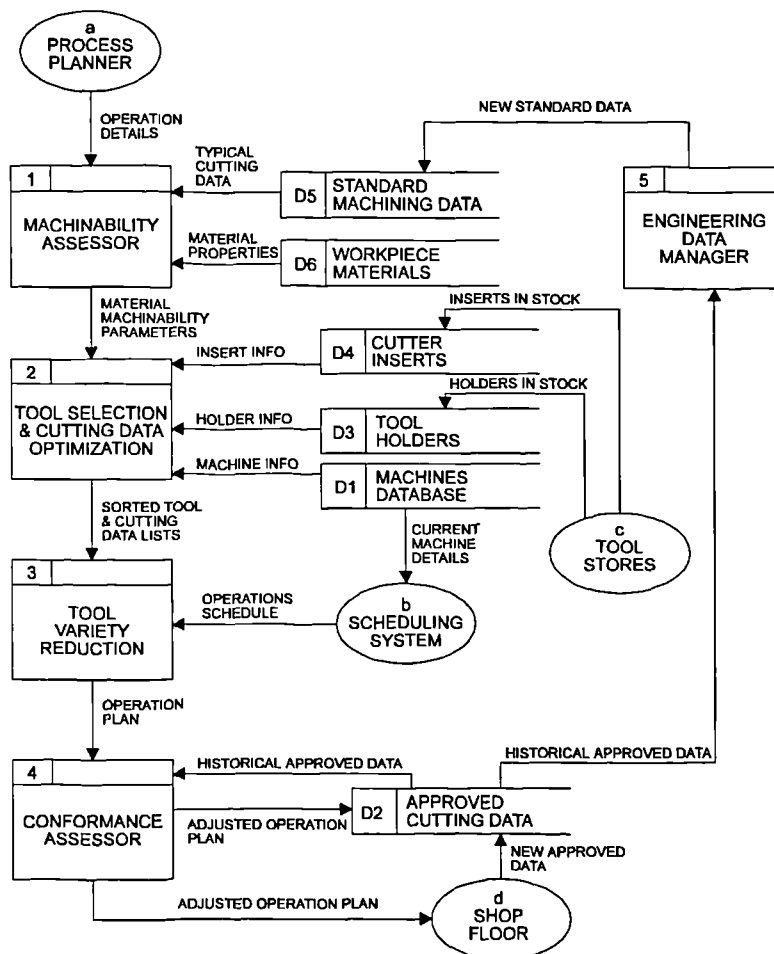

Figure 3.2: Functional layout of the OPTIMUM system

3.3 Overall layout

The top level interface of the OPTIMUM system is shown in Figure 3.3.

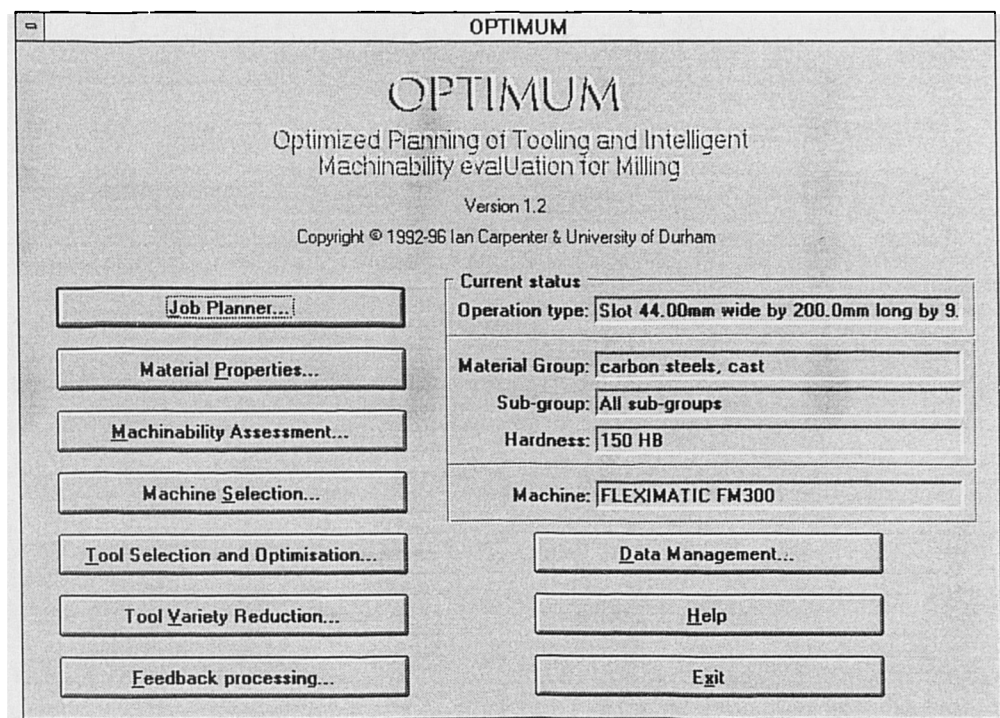

Figure 3.3: Top level menu interface of OPTIMUM

The available menu options are:

1. Job planner

Geometric descriptions of generic milling operations may be input using a simple icon based interface.

2. Material properties

The workpiece material can be specified in several different ways according to the data that is available.

3. Machinability assessment

Initial cutting data can be generated from a variety of input data.

4. Tool Selection and Optimization

Tools are selected and optimized cutting data is generated according to a set of user-specified criteria.

5. Tool variety reduction

A set of selected tools for a group of related operations (for one component,

say) may be rationalized in order to fit onto a limited set of automated tool change positions.

6. Feedback processing

The differences between the suggested cutting data and 'approved' cutting data, that has been proved on the shop floor, is analysed and used to improve the feasibility of cutting data generated in the future.

7. Data management

The initial starting state of the OPTIMUM system (i.e. with no shop floor approved data stored) is maintained by approximately 4.5 MB of data stored in dBase compatible data tables. The data management module provides the user with a user-friendly interface to maintain (add, edit, delete, view) this data.

3.4 Development tools

The initial prototype implementation of the CAPP algorithms in OPTIMUM was developed in the C programming language using the PC-based Borland C/C++ 3.1 development package. A custom windowed interface was written to facilitate the operation of the first version of the tool selection and cutting data optimization module [Carpenter & Maropoulos (1993)].

The conceptual design stage of the machinability assessment module suggested that highly efficient data management functionality would be required to manipulate the large amounts of data required. Whilst C is an extremely powerful language, it is fairly low level and considerable time must be devoted to creating certain complex functions that are provided in higher level languages. Thus, the decision was taken to perform further implementation in a programming language that was better suited to high level data management. The tool catalogue, cutting data tables and quoting system at Seco Tools are all implemented on PC's in FoxBase, an extended clone of the industry standard dBase III database management system (DBMS), produced by Fox Software. The development tool used for all further versions of the OPTIMUM modules is the current descendent of FoxBase, FoxPro 2.6 for Windows (FoxBase is no longer supported). At the time of development, this was the only dBase-compatible DBMS available under the

Microsoft Windows operating environment. FoxPro programs are stored in simple ASCII text files and generally they operate on data tables stored in the FoxPro DBF file format. This format is a slightly extended version of the Ashton-Tate dBase IV table format and thus all the data files in the OPTIMUM system may be viewed and manipulated with any dBase-compatible software i.e. the OPTIMUM software is not required to perform simple database maintenance. This uniformity of data storage format proved to be useful when exchanging data with Seco Tools and when performing data management on-site. Having purchased Fox Software in 1993, FoxPro is now developed and supported by Microsoft Corporation.

FoxPro 2.6 features a wide range of general programming functions in addition to a comprehensive set of data management functions. Microsoft Windows dialogue boxes for user input may be graphically designed on screen and then converted into the corresponding FoxPro code. FoxPro is widely regarded as the fastest and most efficient DBMS available for the PC because it features an advanced index and table caching algorithm, called Rushmore technology, which can often increase search speeds by more than an order of magnitude.

The OPTIMUM system is implemented in 48,373 lines of FoxPro code and a complete installation occupies 7,621 KB of disk space.

3.5 Data driven application design

Most software systems developed using a DBMS feature two separate parts: the program code and the data tables upon which the program acts. Whilst the program code is generally fixed due to the compilation or interpretation process used to execute it, the contents of the data tables are liable to change considerably during the working life of the software. The inflexible nature of these programs is problematic in an industrial environment as there is likely to be a requirement to change the program for two main reasons: maintenance and redesign. General program maintenance will be required to implement bug fixes and minor enhancements. Redesign is often required because most software does not perfectly fit the users requirements first time. Also the software specification may change as, for instance, when a new type of tool is to be purchased.

In order to minimize the impact of the latter, the OPTIMUM system is designed according to the principle of *Data Driven Operation*. This means that any elements of the operation of the program that are likely to change in the future are removed from the fixed code and stored in the more easily changed data table format. Thus, if some simple changes are required in the future it will often be possible to keep the compiled program in its current form and merely alter one or more of the supporting data tables.

A good example of this data driven design philosophy is in the specification of the machining operations described in detail in the following section. The available machining operations are not hard coded but stored in a single data table that contains the name of the operation, a short code for storage purposes, the number of dimensions required and the name and units of each of these dimensions. The operations data table used in OPTIMUM is shown in Table 3.1.

Operation	Dim 1	Unit 1	Dim 2	Unit 2	Dim 3	Unit 3	Dim 4	Unit 4	Dim 5	Unit 5	Dim 6	Unit 6	Code
Face	Width	mm	Length	mm	Depth	mm	Finish	μm					F
Shoulder	Width	mm	Length	mm	Depth	mm	Finish	μm					Q
Drilled hole	Diameter	mm	Depth	mm	Finish	μm							D
Slot	Width	mm	Length	mm	Depth	mm	Finish	μm					S
Chamfer	Width	mm	Length	mm	Angle	°	Finish	μm					C
Pocket	Width	mm	Length	mm	Depth	mm	Corner radius	mm	Finish	μm			P
T-slot	Width	mm	Length	mm	Depth	mm	Neck Width	mm	Neck Depth	mm	Finish	μm	T
Threaded hole	Diameter	mm	Depth	mm	Pitch	mm							H
Radius	Length	mm	Radius	mm									R
Profile	Minimum radius	mm	Cutting length	mm	Depth	mm							O
Plunge	Width	mm	Length	mm	Depth	mm	Finish	μm					L
Through pocket	Width	mm	Length	mm	Depth	mm	Corner radius	mm	Finish	μm			U
Closed slot	Width	mm	Length	mm	Depth	mm	Corner radius	mm	Finish	μm			E

Table 3.1: Milling operation details used for data driven program execution

3.6 Operation geometry definition

One of the main input data requirements of the OPTIMUM system is a description of the geometry of the milling operations to be considered. Currently a simple icon based interface is used to input these data records. Component records containing one or more milling operations are maintained using the interface shown in Figure 3.4.

Component Definition

Component name:

Operation: 6 of 8

Width	40.00	mm
Length	200.00	mm
Depth	18.00	mm
Neck Width	30.00	mm
Neck Depth	15.00	mm
Finish		μm

Buttons:

Bottom Buttons:

Figure 3.4: Component record maintenance interface

Individual milling operations within a component may be added or edited using the interface shown in Figure 3.5. It is worth noting that, unlike traditional CAPP systems, this method of operation definition allows two levels of detail requirement. To execute the machinability assessment method, a complete operation definition is not mandatory. The minimum data required is an operation type and an indication of the type of operation, such as roughing, semi-roughing or finishing. Typical values of axial depth of cut for these three operation subtypes are 8 mm, 4 mm and 1 mm, respectively. This method of flexible operation definition allows rapid evaluation of the likely machinability characteristics of an operation even when a complete description of the operation geometry is not available, such as during the conceptual design stage. The ability to produce feasible cutting data at the earliest stages of the product development cycle is

useful when attempting to implement concurrent engineering methods, as process planning information is required much earlier in the product cycle than in a more traditional engineering development environment.

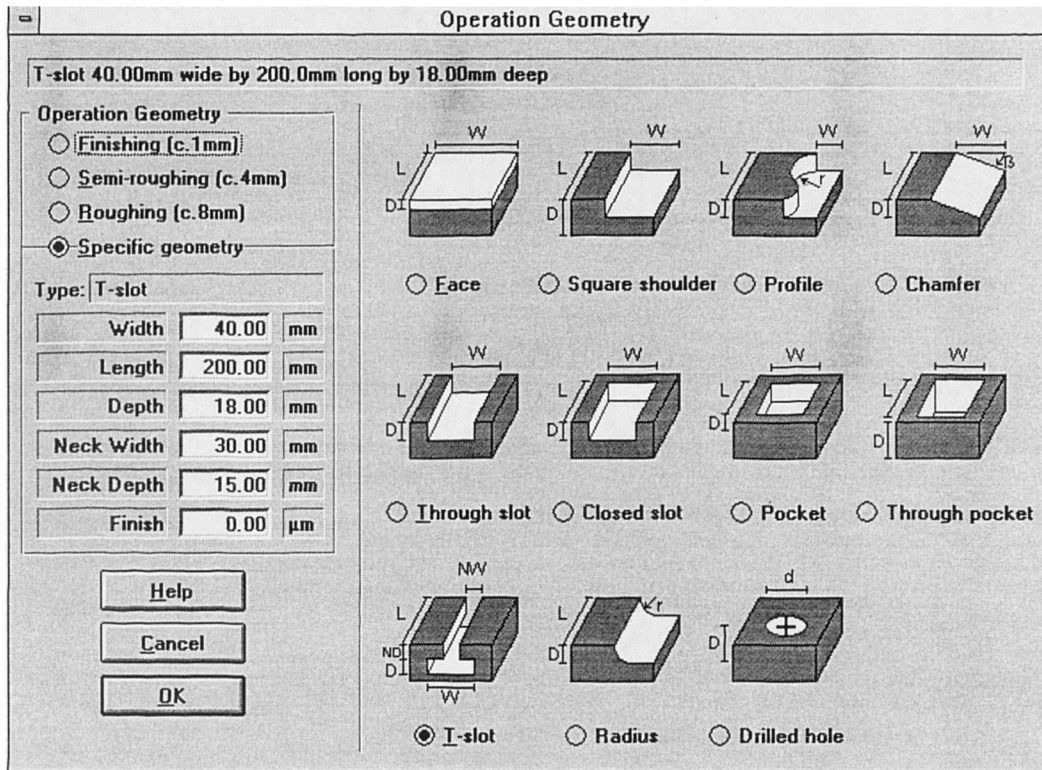

Figure 3.5: Operation definition interface

For effective tool selection and cutting data optimization, exact operation dimensions are required to facilitate comprehensive geometric suitability checking of tools. The operation geometry interface is used to generate a simple, tabular description of the component that consists of a list of operations and associated dimensions (see Appendix A for the table format). Whilst this interface is appropriate for rapid operation of the system, the simple format of the component descriptions used suggests that this is a fruitful area for investigating links to CAD/CAM systems that handle complete geometric descriptions of engineering components.

3.6.1 Interfaces with CAD/CAM

As mentioned in Chapter 2, much research and development effort has been expended in enhancing the ability to handle component geometries with software rather than large amounts of hand executed drawings. Indeed, modern engineering companies use

CAD/CAM technology to design new parts and communicate these designs as efficiently as possible to the appropriate manufacturing function.

During the craft manufacturing period, design, process planning and manufacturing process were all combined, in the form of the individual craftsman. However, since before the industrial revolution engineering projects have gradually become too complex for any one person to completely oversee. Modern manufacturing industry can now produce products of great size and complexity such as, for example, the Boeing 777 airliner which is fabricated on a production line from over 6 million separate parts. The design process has progressively become divorced from the manufacturing process as design responsibility was transferred from the craftsman to separate design departments. The functional features of a part have become separated from the methods of producing them. This has led to attempts to map design features onto manufacturing processes. This mapping has been tackled with the two different approaches of feature based design and automated feature recognition.

The first, feature based design, requires a fundamental rethink of the design method so as to constrain designers to only using a set of standard features that are easily produced with standard process plans. This is one of the most recent and promising techniques for enhancing process planning and it is emerging as a common design methodology within many large companies [Maropoulos (1995b)]. Salomons *et al.* (1993) present a comprehensive review of recent research in feature based design.

The second approach, automated feature recognition, seeks to improve the flow of design information to manufacturing by not altering the design method directly but by inferring easily manufactured features directly from the given part geometry. As an exercise in computational geometry, feature recognition has been the subject of a large amount of research work over the last twenty years, with varying degrees of success. As with computer-aided process planning, a variety of prototype feature recognition systems have emerged over the last thirty years, mostly from academic institutions [Subrahmanyam & Wozny (1995)]. Considering the almost infinite variety of component geometries that may be found in modern engineering manufacture, most feature

recognition systems require some important assumptions that limit the applicability of the recognition algorithm to certain types of features. Another major limitation of feature recognition is that technological information about the features must be added after the recognition process. A typical CAM cycle in a feature based environment is shown in Figure 3.6.

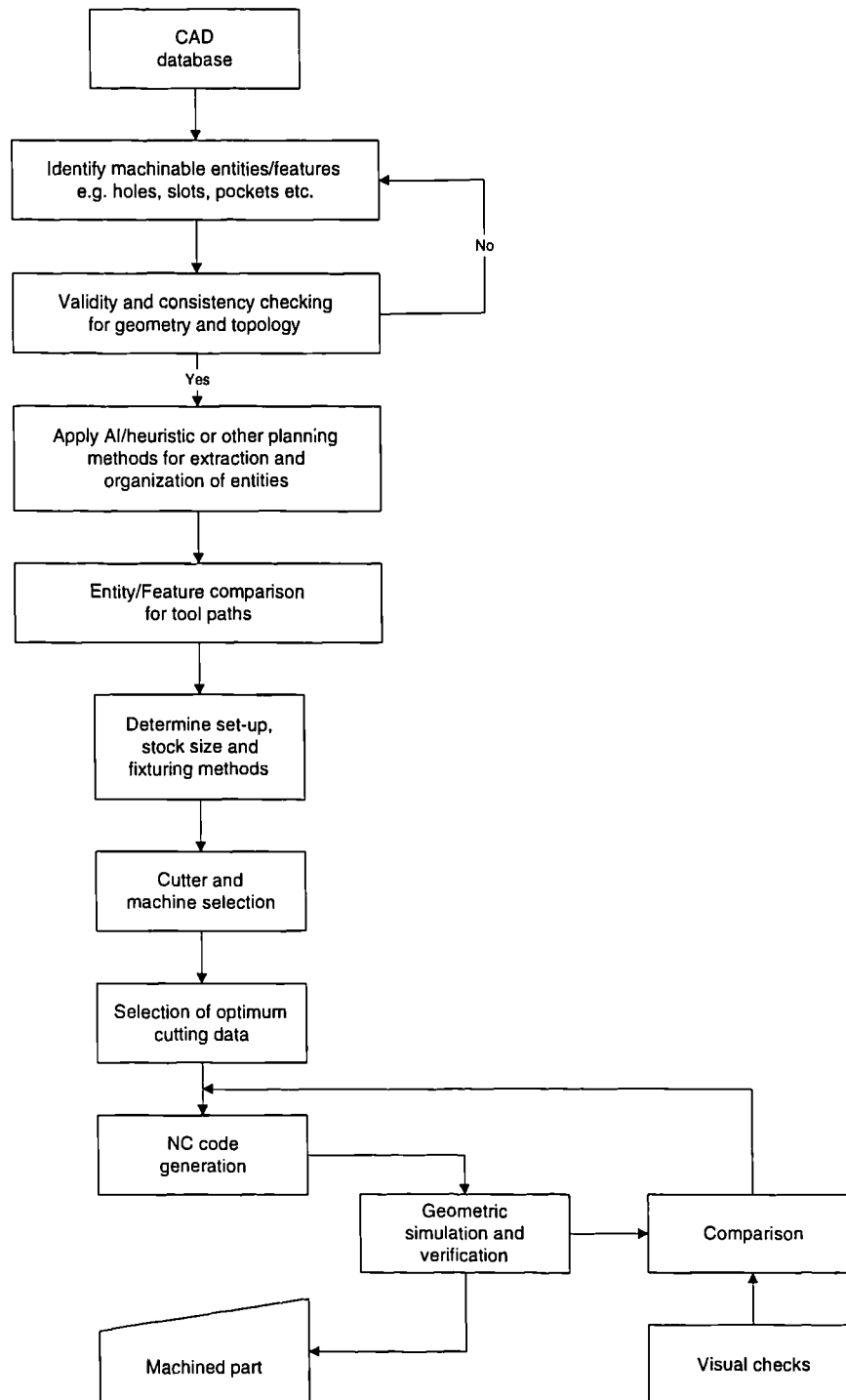

Figure 3.6: The CAM cycle in a feature-based design environment (after Subrahmanyam & Wozny 1995)

Most of the operations that can be planned by the OPTIMUM system are of a simple, straight sided type as shown in Figure 3.5. It is anticipated that an efficient link to a CAD/CAM geometric model of a component could be achieved if a simple list of features corresponding to the OPTIMUM basic operation set is extracted from the solid model. In its current implementation, this is feasible as there is an ever increasing range of advanced CAD/CAM packages available for the PC running under Microsoft Windows 3.11. Using modern database client/server technology, it is possible to link a PC based DBMS such as FoxPro with many other proprietary data systems running on other remote machines, facilitating automatic links to the local scheduling software (to define which machines are available and for which components) and the tool management software (to maintain the tables of currently available tools). Combined with a method to automatically extract feature information from CAD models, it is realistic to believe that the OPTIMUM CAPP system could form part of a largely automated process planning system that requires minimal user intervention. This would entail fixed data links between all the elements shown in Figure 3.1.

In summary, having defined a component geometry, one operation can be selected from the dialogue box shown in Figure 3.4 and the other functions shown in Figure 3.2 become available. The other four main functional modules in OPTIMUM, namely the machinability assessor, tool selection and cutting data optimization method, tool variety reduction and conformance assessor, are described in detail in the following four chapters.

Chapter 4

Machinability assessment

This chapter describes the rationale, algorithm and implementation of the machinability assessment module of the OPTIMUM system. The module produces initial cutting conditions for a wide range of material and tools. The method is data driven and highly flexible and tolerant, enabling it to function effectively with a large variety of input data including incomplete or imprecise data. The workpiece material can be specified in one of three ways: by standard designation, by general material type or by partial or complete chemical composition. In the latter case, a rule based system is used to classify the material within a group of similar materials. Cutting data is then calculated using multiple regression techniques on a database of cutting conditions relating to the selected material group. Finally the user may specify adjustments to the cutting data to accommodate specific insert grades and exact values of depth of cut.

4.1 Introduction

It is widely reported that the levels of machining knowledge that process planners in industry are able to draw upon is diminishing. With the demise of the apprenticeship schemes many engineers entering process planning departments do not have extensive experience as machine operators. As the market for machined parts expands across the globe, process planners and machine operators are likely to encounter alloys that are not well known or fully specified. Recently there has been a considerable expansion of the use of high performance alloys from the aerospace industry into the fields of food processing and medical equipment. It is difficult to plan for efficient machining with the wide variety of workpiece materials that may be encountered in the global manufacturing

market. Customers often contact a tool manufacturer by telephone requesting advice, invariably in relation to cutting data. Thus, tool manufacturers are required to support their products by producing complete tooling solutions including sets of cutting conditions. Unfortunately, the amount of workpiece material information available is often low with few precise details of material type or composition. An automated method of providing initial cutting conditions for a wide range of materials and tools that can accommodate incomplete input data is required.

The concept of providing automated machinability assessment was added to the research programme during the first year when the extent of machinability queries became apparent. In order to effectively compete in the aggressive modern tool marketplace, a tool manufacturer, such as Seco Tools, must be able to provide state of the art cutters and inserts as well as a comprehensive technical support service including machinability assessment and cutting data calculations. However, the technical support team at Seco were hampered by the poor quality of material related information provided by their customers, particularly for new or foreign materials.

The machinability assessor module of OPTIMUM is an initial working solution for this problem. The overall layout of the module is shown in Figure 4.1. The assessor is implemented as several separate functions performed in sequence to generate initial cutting conditions. The remaining sections of this chapter describe the rationale behind the approach used and the methods used for each of the main functional blocks shown in Figure 4.1.

4.2 Investigation of machinability

As mentioned in the literature review, there has been considerable research interest in the assessment of machinability. The published literature has shown that machinability can be related to chemical composition, microstructure and physical properties (often surface hardness). A detailed microstructural analysis of a material prior to machining requires time and equipment that is beyond the means of many machine shops. Also, microstructure information can be prone to a degree of subjectivity in its description and

this renders it an unsuitable form of information to request for automated machinability assessment.

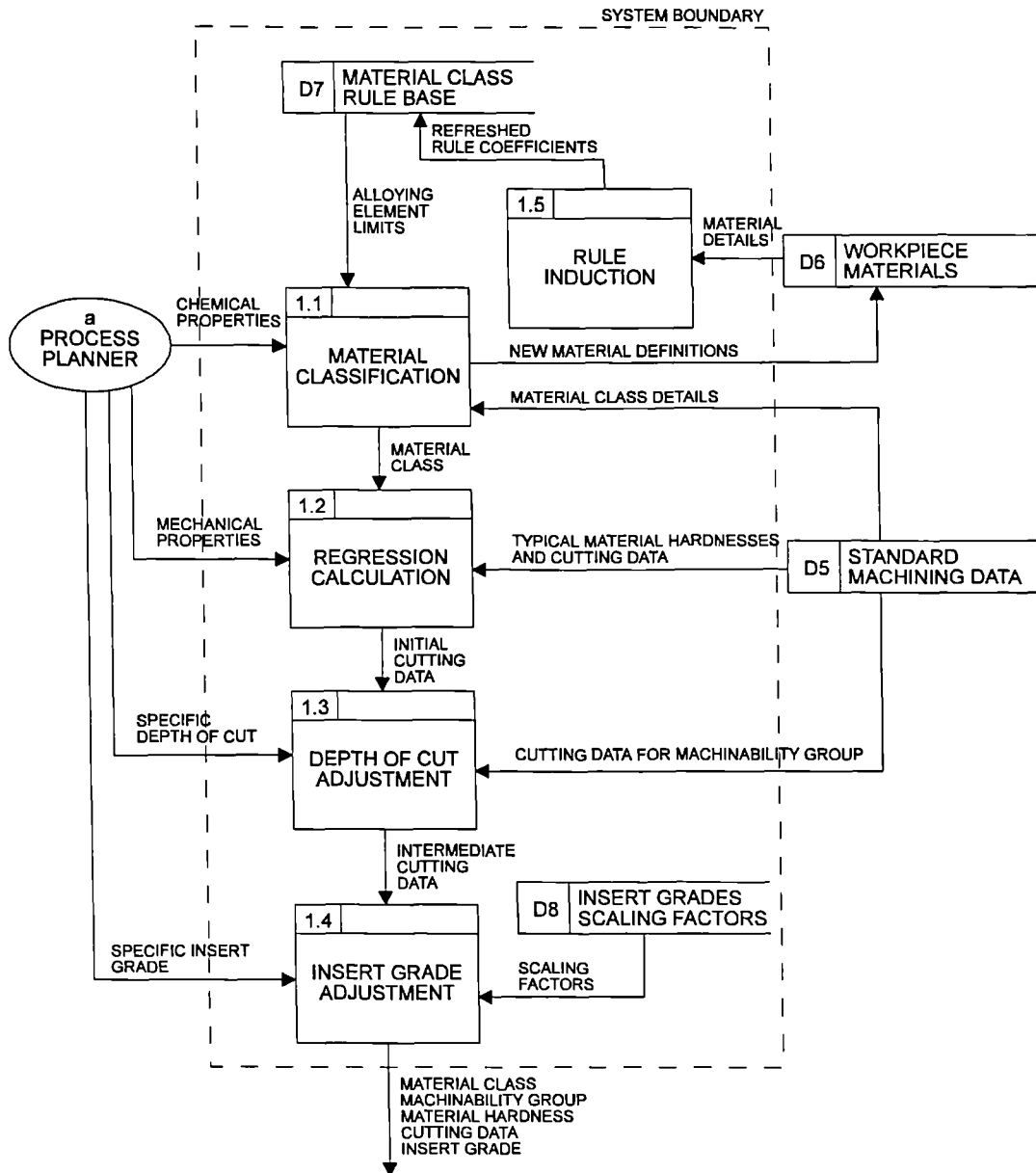

Figure 4.1: Overall layout of machinability assessment module

It is likely that a more easily obtainable description of the material will be either a description of the class of material or the chemical composition. If a chemical composition can be obtained (either from an experimental analysis or from a material standard designation) then it may be possible to relate this to the material's machining properties. Examples given in section 2.5.1 demonstrate experimentally derived

relationships between the proportion of alloying elements and machining characteristics for highly restricted ranges of ferrous alloys. An initial investigation was performed to ascertain if any suitable equivalence statements exist that can be used to relate chemical composition to machinability for a wider set of engineering materials. Some equivalence statements available from engineering handbooks are:

1. The weldability of carbon-manganese steels is given by:

$$CE = \%C + \frac{\%Mn}{6} + \frac{\%Cu + \%Ni}{15} + \frac{\%Cr + \%Mo + \%V}{5} \quad (4.1)$$

2. The weldability of higher strength low alloy steels is given by:

$$P_{CM} = \%C + \frac{\%Si}{30} + \frac{\%Mn + \%Cu + \%Cr}{20} + \frac{\%Ni}{60} + \frac{\%Mo}{15} + \frac{\%V}{10} + 5\%B \quad (4.2)$$

3. The effect on tensile strength for unalloyed irons is given by:

$$CEV = \%C + \frac{\%P + \%Si}{3} \quad (4.3)$$

Unfortunately all these equivalence statements are only applicable for small ranges of materials and describe physical characteristics that are not simply related to machining properties.

A method for relating the chemical composition of stainless steels with their microstructure is given by the Schaeffler diagram [Schaeffler (1948), (1949)]. This diagram attempts to define the phase of a stainless steel (e.g. ferritic, austenitic, martensitic) by reference to regions on a graph of Chromium equivalent against the Nickel and Chromium equivalents, which are given by:

$$Nickel\ equivalent = \%Ni + 30\%C + \frac{\%Mn}{2} \quad (4.4)$$

$$\text{Chromium equivalent} = \%Cr + \%Mo + \frac{3\%Si}{2} + \frac{\%Nb}{2} \quad (4.5)$$

A typical Schaeffler diagram is shown in Figure 4.2

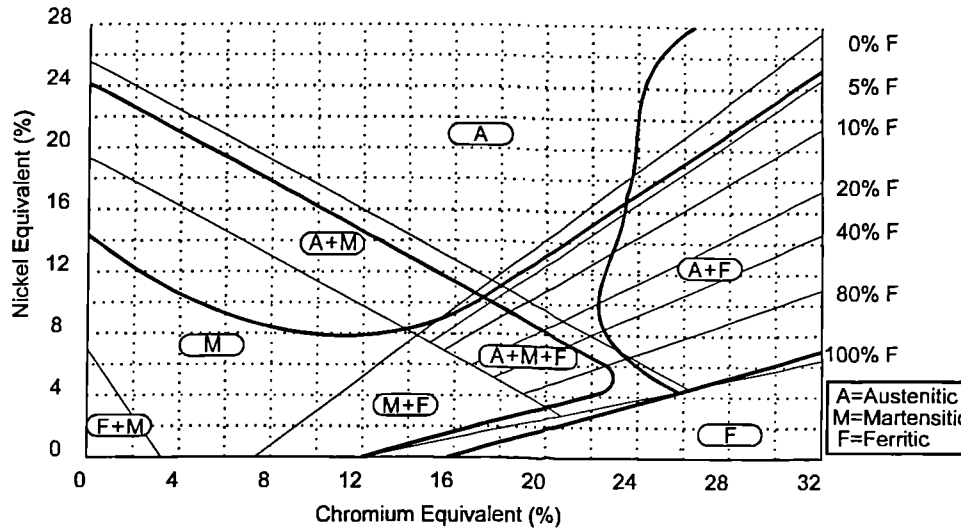

Figure 4.2: Schaeffler diagram for stainless steels

The Schaeffler diagram was developed to assist in prediction of the microstructure of stainless steel weld material. However, when attempting to apply it to machinability evaluation, it is necessary to find relationships between the main areas of different microstructure shown in Figure 4.2 and typical machining parameters.

Stainless steels can be broadly divided into four groups: austenitic, martensitic, ferritic and precipitation hardening. Properties that influence the machinability characteristics include the following:

1. Stainless steels have a higher tensile strength and greater gap between yield and fracture stress than plain carbon steels. Thus more energy is required to machine stainless steels than non-hardened carbon steels.
2. Austenitic stainless steels have high work hardening rates and low thermal conductivity resulting in high energy consumption compared with plain carbon steels. Also the low thermal conductivity tends to cause high temperatures at

the chip-tool interface resulting in high rates of diffusion wear on the tool (diffusion wear is highly temperature dependent).

3. Higher alloy stainless steels contain abrasive carbide causing accelerated tool wear. Whilst annealed martensitic stainless steels can be cut in a similar way to low carbon steels, the rate of tool wear is much higher. In general ferritic grades machine in a similar way to annealed martensitic grades. Austenitic grades are less machinable than ferritic and martensitic grades but this may be improved with the use of free machining additives

Much research has centred on the effect of ductility on the machining characteristics of stainless steels. It has been suggested that a lower ductility improves machinability by causing primary deformation zone fracture, thus easing chip removal and that the addition of sulphur, selenium and tellurium causes an increase in machinability by a reduction in ductility [Tipnis (1970)].

The composition, quantity and physical properties of non-metallic inclusions effect the machining properties of stainless steels. Certain amounts of chromium and/or molybdenum facilitate the creation of complex non-metallic sulphide inclusions. It is also possible to create manganese sulphide inclusions, such as those found in low carbon free-machining steels. It has been found that increasing the ratio of manganese to sulphur offers much reduced tool wear and increased tool life up to a ratio of about 7, after which the beneficial effects are much reduced. With increased manganese content the composition of the inclusions can range from CrS to (Fe Mn)Cr₂S₄ to (Mn Fe Cr)S to MnS. Metallographic studies have shown that manganese sulphide inclusions are deformed into thin plates and thus may tend to wrap around the tool edges and offer some protection. However chromium inclusions tend to break up into discrete particles and therefore may be a cause of abrasion on the tool surfaces.

As stated previously, the addition of selenium, sulphur and tellurium can increase the machinability of stainless steels considerably. Sulphur is the most effective in this regard whilst selenium tends to give the best surface finish. However selenium and tellurium

reduce the hot-working properties of stainless steels and must be added under carefully controlled melting conditions.

In summary, the overlapping regions shown in the Schaeffler diagram combine with the complex machining mechanisms found in stainless steel to make it very difficult to relate either Nickel equivalent or Chromium equivalent directly with machining parameters. When plotted on the Chromium-equivalent/Nickel-equivalent axes, the non-precipitation-hardening stainless steels produce the graph shown in Figure 4.3. Also, of course, the Schaeffler equivalence statements are not applicable for any other types of engineering alloy.

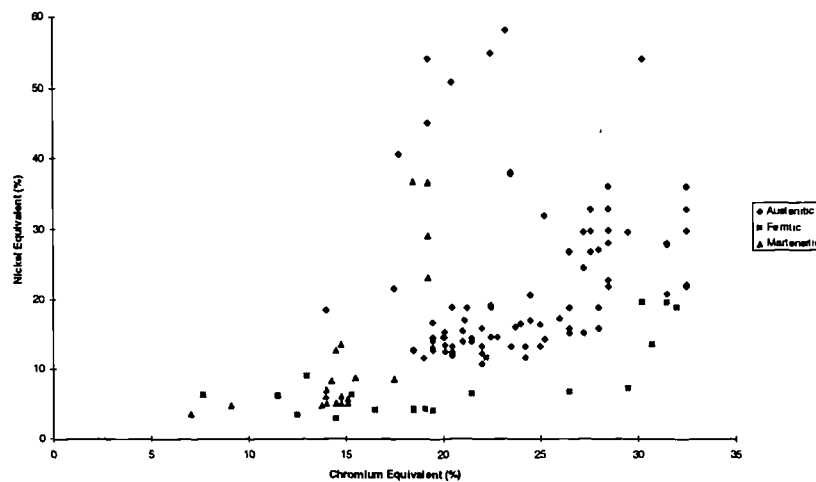

Figure 4.3: Stainless steel phase type plotted on the Schaeffler chromium equivalent against nickel equivalent graph

Various brief investigations into the equivalence statements listed in this section showed that there is no simple mathematical method for relating cutting conditions to material properties for a feasibly wide range of workpiece materials. Thus, the approach taken was to find a method of classifying the workpiece material into a small group of materials that exhibit sufficiently similar machining responses to allow a mathematical evaluation of the cutting conditions based on simple material properties.

4.3 Material classification

The first function shown in Figure 4.1 is the classification of the workpiece material. This can be achieved in several ways depending upon what material data is available. This section describes the building of the main data tables for material designations and standard cutting parameters. This is followed by an examination of the three alternative methods used for material classification.

4.3.1 Data sources

One of the most important tasks in constructing a machinability assessment method was to find one or more suitable sources of cutting data. These sources must provide enough machining data with associated material properties to allow a consistent method of relating material properties to machinability across a significant number of engineering materials.

The main source of data used in this research is the *Machining Data Handbook* [Metcut Research Associates (1980)]. This is one of the broadest and most comprehensive sets of cutting data for a wide range of cutting operations, workpiece materials and tool types. The data is presented as values of cutting velocity for a set of discrete values of cutting depth and feed per tooth. The workpiece materials are divided into small groups of between one and about twenty materials which share similar machining characteristics. These groups are further divided into discrete ranges of surface hardness and conditioning. Cutting data is supplied for High Speed Steel tools, uncoated carbide tools and coated carbide tools. A portion of a typical cutting data table is shown in Table 4.1.

MATERIAL	HARDNESS	CONDITION	DEPTH OF CUT	HIGH SPEED STEEL			CARBIDE TOOL						
				TOOL			UNCOATED			COATED			
				SPEED	FEED PER TOOTH	TOOL MATERIAL	BRAZED	INDEX-ABLE	FEED PER TOOTH	TOOL MATERIAL GRADE	SPEED	FEED PER TOOTH	TOOL MATERIAL GRADE
				in mm	ipm m/min	in mm	AISI ISO	ipm m/min	ipm m/min	in mm	C ISO	ipm m/min	in mm
1. FREE MACHINING CARBON STEELS, WROUGHT Low Carbon Resulfurized 1116 1118 1211 1117 1119 1212	100 to 150	Hot Rolled or Annealed	0.040	155	0.005	M2,M7	550	600	0.005	C-6	900	0.005	C-6
			0.150	120	0.007	M2,M7	410	450	0.007	C-6	590	0.007	C-6
			0.300	95	0.009	M2,M7	290	350	0.009	C-5	450	0.009	C-5
			1	47	0.13	S4,S2	170	185	0.13	P20	275	0.13	CP20
			4	37	0.18	S4,S2	125	135	0.18	P30	180	0.18	CP30
Low Carbon Resulfurized 1213 to 1215	150 to 200	Cold Drawn	8	29	0.23	S4,S2	88	105	0.23	P40	140	0.23	CP40
			0.040	150	0.005	M2,M7	500	550	0.005	C-6	825	0.005	C-6
			0.150	115	0.007	M2,M7	375	410	0.007	C-6	530	0.007	C-6
			0.300	90	0.009	M2,M7	260	310	0.009	C-5	400	0.009	C-5
			1	46	0.13	S4,S2	150	170	0.13	P20	250	0.13	CP20
4	35	0.18	S4,S2	115	125	0.18	P30	160	0.18	CP30			
8	27	0.23	S4,S2	79	95	0.23	P40	120	0.23	CP40			

Table 4.1: Sample cutting data from the Machining Data Handbook

The *Machining Data Handbook* provides cutting data for a total of 1385 materials which are divided into 53 main material groups, henceforth referred to as *Material Groups*. These groups are further divided into 179 subgroups which are used to define the groups of materials that exhibit sufficiently similar machinability to require the same cutting data, henceforth referred to as *Machinability Groups*. Each material group contains at least one machinability group. In Table 4.1 the material group is “Free machining carbon steels, wrought” and the machinability group is “Low carbon resulfurized”. As the most recent edition of the *Machining Data Handbook* was published in 1980, there is cutting data for various generic carbide grades but advanced modern carbide grades are not explicitly catered for. A full list of the material groups and subgroups is given in Appendix B.

The user may select a method of material specification using the dialogue box shown in Figure 4.4. The following three sections describe in detail each of the three material specification methods.

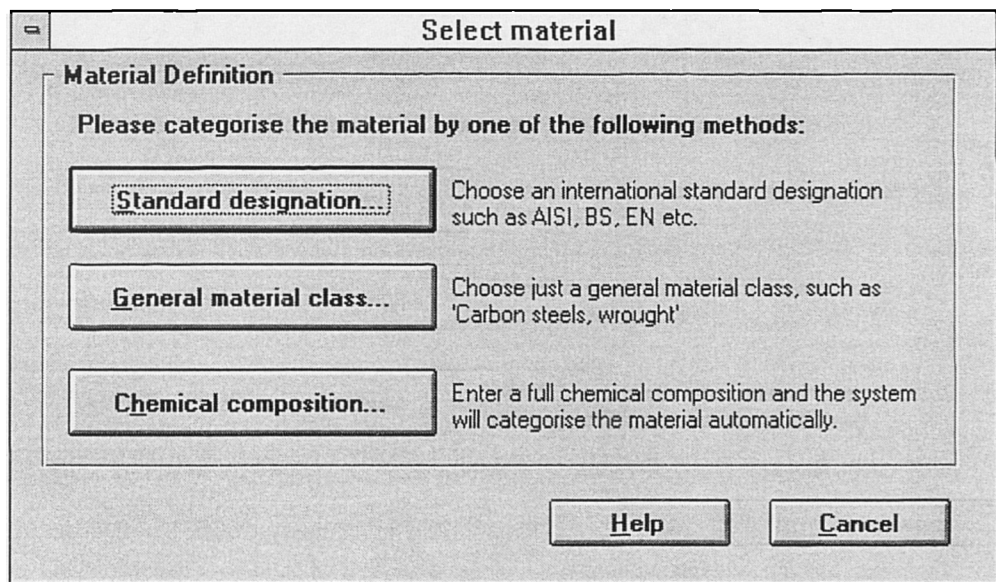

Figure 4.4: Selection of material specification method

4.3.2 Classification by standard material designation

Possibly the most straightforward method of material classification is the use of standard material designations. Many governments and engineering bodies around the world have produced standards for material description. Common designation systems are listed in Table 4.2.

Standard	Country
EN (Emergency Number)	Great Britain
BS (British Standard)	Great Britain
AISI	U.S.A.
AFNOR	Italy
WS	Germany
EuroNorm	E.C.

Table 4.2: National and International Material Designation Standards

These standards provide a concise nomenclature for precisely defining a material. There are certain similarities between these standards and it is generally possible to map a material description from one standard to another. Some standards include more materials than others (WS is particularly comprehensive) and some are at different stages of their life cycle (BS is intended to supersede EN, which was used during the Second World War; EuroNorm is a new standard designed to assist trade within the European Community). Materials are referenced in the *Machining Data Handbook* by the American AISI standard and it is this standard that is used throughout the OPTIMUM system.

The user may select the AISI standard designation of the workpiece material using the interface shown in Figure 4.5. The number of possible designations is too large for a simple list box to be a practical method of selection. Therefore, the user may filter the designations by both general material type and material group to reduce the size of the list of possible designations.

The provision of a complete material standards database that relates the various national standards together would be a useful element of any further industrial development programme.

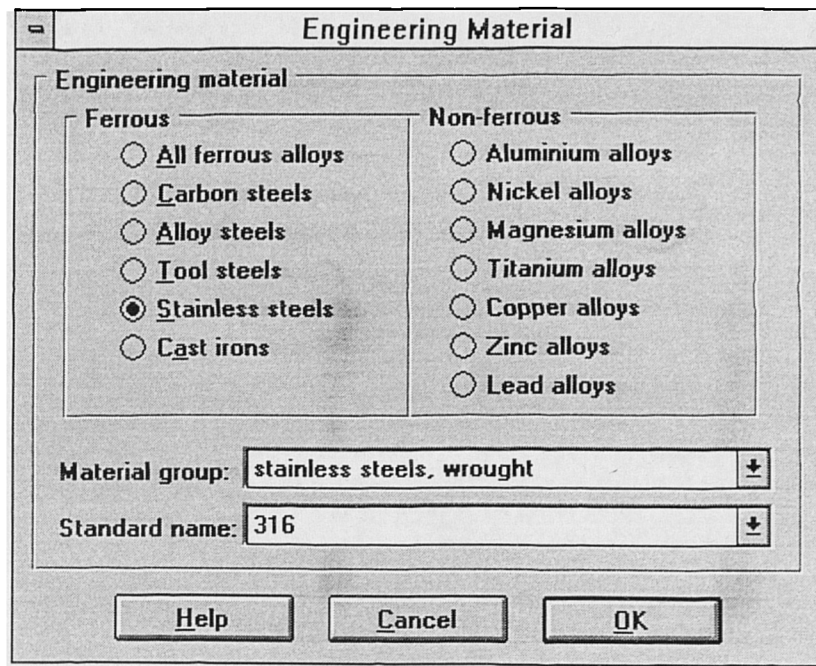

Figure 4.5: Material specification by AISI standard designation

4.3.3 Classification by material group

If a standard material designation is not available, the material may be specified by general material group. The user may place the material within a material group and optionally within a machinability group by using the dialogue box shown in Figure 4.6.

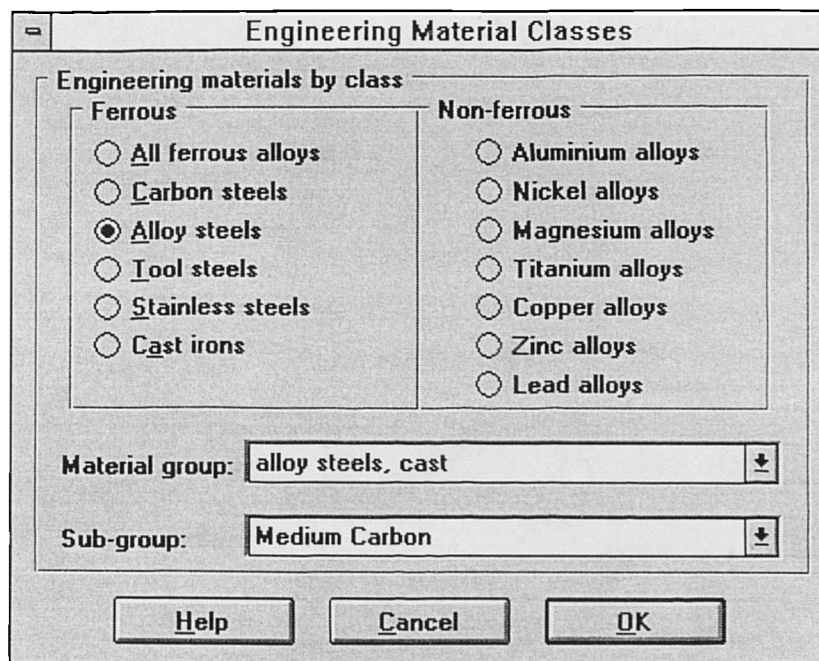

Figure 4.6: Material specification by material group

As with the material standards dialogue box described in the previous section, the material groups and their associated machinability sub-groups may be filtered by selecting from a set of radio buttons representing broad material types. This provides a method of rapidly presenting a set of suitable material group descriptions that may be applied to the material under consideration. However, this method of description is clearly much coarser than using a standard material designation and this makes the production of precisely calculated cutting parameters rather more difficult.

4.3.4 Classification by material composition

The layout of the machining data in the *Machining Data Handbook* provided useful clues as to the possible approaches to machinability assessment. Materials are divided into material and machinability groups which contain materials of similar type. Thus materials that exhibit similar machining data but are of different types are not listed together (for instance, some carbon steels may be cut with the same cutting conditions as some free machining stainless steels).

The different types of material identified by these groups are all ultimately defined by their chemical composition (e.g. the percentage of certain alloying elements defines whether a steel is stainless or not) and a flexible method is required to relate the chemical composition of a material to its material and machinability group.

4.3.5 Rule-based systems

The range of ferrous materials under consideration features wide variations in chemical composition and machinability. The chemical and physical mechanisms influencing machinability can vary greatly between different ferrous alloys. Thus it is highly unlikely that a deterministic mathematical model would be suitable for categorizing a material into a material group or subgroup by chemical composition.

The input data for this categorization problem contains a large number of independent variables since the main steels material table features eighteen alloying elements. The single output variable is material group which can be given a discrete numeric value by sequentially numbering the possible material groups and subgroups. This form of

problem is ideally suited to solution using rules. A typical form of rule is the classic IF...THEN statement of the following form:

IF <logical condition> THEN <outcome>

Rule-based systems have gained considerable popularity due to the flexibility afforded by the ability to evaluate rules or parts of rules in any order. The uniform format of the data contained in a rule base also allows the rule base to be extended without having to extend or alter the rule evaluation mechanism. In some cases rules may even be used to generate further rules that can encapsulate complex decision logic that may not be easily found by the rule designer. One of the main disadvantages of rule-based systems is the process of rule generation. This process is often referred to as knowledge elicitation due to the fact that many “knowledge-based systems” are implemented with a rule architecture [Hart (1986)]. This process has been widely reported as a bottleneck in the development and maintenance process and considerable research effort has been expended on creating efficient tools to assist the knowledge collection and formalization process [Gaines & Shaw (1993)]. If a rule-based system is to be used for automated categorization of material by chemical composition then it is very important that the rule base be easy to generate, update and extend.

4.3.6 Automatic rule induction methods

In order to induce a set of rules relating chemical composition to material type, it is necessary to build a training suite of example data sets, each consisting of a set of input variables and the appropriate output variable(s) [Quinlan (1979)]. Fortunately this is a relatively straightforward task when applied to the material categorization problem as the training data can be extracted from the system’s main materials database.

The rule base was induced using a commercial package called the Crystal Induction System [Intelligent Environments (1992)]. This is an add-on module for a commercial expert system shell called Crystal which is produced by Intelligent Environments. The package runs under MS-DOS and allows the importing of tables of example data in the simple Comma Separated (CSV) text format. A typical set of example data is shown in

Table 4.3 (for the wrought stainless steel AISI 422 which lies in the material group 13, subgroup 59).

Fe	C	Cu	Ni	Cr	Mn	P	S	Mo	Ti	Pb	Co	B	Nb	W	V	Al	Si	N	Group
81.58	0.25	0.00	0.75	13.00	1.00	0.04	0.03	1.00	0.00	0.00	0.00	0.00	0.00	1.00	0.35	0.00	1.00	0.00	59

Table 4.3: Example data set for automatic rule induction

Executing the rule induction system on a table of examples of this form will produce a set of simple rules that relate the input variables to the outcome variable. This rule set should be sufficient to correctly categorize at least all the materials from which the example data is drawn, with one exceptional case. If there are two or more example data sets that consist of similar input variables but different output values then it may be impossible to induce unique rules to correctly classify these materials. In this case, full rules are generated but they are given the final outcome value of “*Uncertain*” rather than a material group number. The handling of these uncertain rules is described in section 4.3.8. The rules are output in a plain text form that is suitable for importing into the Crystal expert system shell. These rules are expressed as shown in Figure 4.7.

```
Material Group is 4 (free machining carbon steels, wrought)
IF      Si is less than 0.275          OR      Si is less than 0.275
      AND NOT P is less than 0.025      AND NOT P is less than 0.025
      AND C is less than 0.575          AND C is less than 0.455
      AND NOT C is less than 0.295      AND NOT C is less than 0.295
      AND Fe is less than 98.515        AND Fe is less than 98.620
      AND NOT S is less than 0.075      AND NOT Fe is less than 98.515
      AND Pb is less than 0.125         AND S is less than 0.075
```

Figure 4.7: A typical automatically induced rule

As can be seen in this example, a rule can contain several clauses connected by logical OR or AND statements and each clause can contain several logical conditions connected by AND statements. The rules may not be a minimal form i.e. they may contain redundant conditions as shown in Figure 4.8.

```
Material Group is 4
(free machining carbon steels, wrought - medium carbon resulfurized)
IF      Si is less than 0.275
      AND NOT P is less than 0.025
      AND C is less than 0.455
      AND C is less than 0.575
```

Figure 4.8: A rule with redundant conditions

A more extensive selection of the induced rule base is listed in Appendix C. The last condition is redundant as it is a subset of the penultimate condition. These redundant conditions are removed in the rule parsing procedure described in the following section.

4.3.7 Formatting of induced rules

As the rule induction system produces rules in a format for importing into the Crystal Expert System Shell, it is necessary to translate them into a format that will allow them to be manipulated and evaluated from within the FoxPro environment. A database management system (DBMS) such as FoxPro is designed to deal with large tables of data and features powerful methods for searching and manipulating records in real time. Thus it is desirable to express the rule base as a table of constraint values that can easily be searched.

The critical constraints found within the rule base are the maximum and minimum percentages of each alloying element. A custom filter program written in C is used to parse the rule text file and generate a simple comma separated data file that consists of one line for each rule clause and includes the maximum and minimum percentages allowed for each alloying element. For example, the two clause rule shown in Figure 4.7 is converted to the form shown in Table 4.4.

As may be seen in Table 4.4, any alloying elements that do not have any logical conditions applied to them are assigned a default minimum percentage of zero and a maximum percentage of one hundred.

4.3.8 Uncertainty handling

Any large set of training data can contain examples that conflict with the induction of unique rules and thus a degree of uncertainty can appear. There may exist one or more examples that, according to the rules generated from all the other examples, could produce more than one outcome (i.e. lie within more than one machinability group). If a system with rule-based logic is to become part of an automated decision mechanism then any degree of uncertainty is undesirable.

Group	4	4
Fe min	0.000	98.515
Fe max	98.515	98.620
C min	0.295	0.295
C max	0.575	0.455
Cu min	0.000	0.000
Cu max	100.000	100.000
Ni min	0.000	0.000
Ni max	100.000	100.000
Cr min	0.000	0.000
Cr max	100.000	100.000
Mn min	0.000	0.000
Mn max	100.000	100.000
P min	0.025	0.025
P max	100.000	100.000
S min	0.085	0.000
S max	100.000	0.085
Mo min	0.000	0.000
Mo max	100.000	100.000
Ti min	0.000	0.000
Ti max	100.000	100.000
Pb min	0.000	0.000
Pb max	0.125	100.000
Co min	0.000	0.000
Co max	100.000	100.000
B min	0.000	0.000
B max	100.000	100.000
Nb min	0.000	0.000
Nb max	100.000	100.000
W min	0.000	0.000
W max	100.000	100.000
V min	0.000	0.000
V max	100.000	100.000
Al min	0.000	0.000
Al max	100.000	100.000
Si min	0.000	0.000
Si max	0.275	0.285
N min	0.000	0.000
N max	100.000	100.000

Table 4.4: Extended data record form of a material categorization rule

To remove any rules that produce uncertain outcomes, the generated rule base is scanned for rules with the outcome “*Uncertain*” and these rules are used to scan the materials file that generated the rules. All the materials that satisfy the uncertain rules are stored and scanned to produce a list of the material groups that they lie within (if these rules really do produce uncertain outcomes then there must be at least two possible machinability groups). The uncertain rules are removed from the rules base and rewritten several times, each new rule featuring one of the possible outcome values as its own outcome.

For example, an uncertain rule is produced of the following form:

```

Material Group is uncertain
IF    P is less than 0.005
      AND C is less than 0.435
      AND Si is less than 0.050
      AND NOT Mn is less than 0.175
      AND NOT Mo is less than 0.100
      AND NOT N is less than 1.500

```

Figure 4.9: A rule with uncertain outcome

Scanning the main materials data table for materials that satisfy this rule produces two materials from the same main material group but falling within different machinability groups, as shown in Table 4.5.

Material Group	Group Name	Machinability Group	Material Name
47	Structural steels, wrought	47	80
47	Structural steels, wrought	49	140

Table 4.5: Two materials that produce a rule with uncertain outcome

The uncertain rule is removed from the rule base and replaced with two new rules, each with the same logical conditions but containing 47 and 49 respectively as outcome value. Thus, the system will not categorize any material into an uncertain group, but rather the material will be categorized into more than one material group and the user can specify which one (or more) to accept.

4.3.9 Rule firing mechanism

The storage of rules as single records in a data table allows a rapid evaluation of a large set of rules using standard database search and filter methods. The categorization of a material into one of the ninety-nine machinability groups currently requires one hundred and eighty two rules. It is a straightforward task to take the user specified material composition and search the rules data table for all those records where each alloying element percentage lies between the maximum and minimum values.

In the unlikely event that a chemical composition satisfies rules for more than one machinability group, a list of the possible groups is presented and the user may select one or more groups for further processing. It is a feature of the whole OPTIMUM system

that, where possible, the user can avoid making any critical decisions and instead allow the system to generate multiple solutions based on all the feasible criteria.

To summarize, the rule-based system provides a highly flexible method of material categorization which can absorb subtle differences between the material under investigation and known reference materials. This method can also account for the slight differences and tolerance ranges present in the standard definitions of many materials and still successfully place the material in a uniform group of materials that exhibit similar machinability characteristics.

4.3.10 Material hardness specification

After the material has been classified into a material group, the surface hardness is specified by the user with the interface shown in Figure 4.10.

The image shows a software dialog box titled "Mechanical Properties". It is divided into two main sections. The left section, titled "Surface Hardness", contains the instruction "Please enter a specific value of surface hardness in the box below:" followed by a text input field containing "225" and a unit dropdown menu set to "BHn". Below this are three buttons: "OK", "Cancel", and "Help". The right section, titled "Typical hardness by class", contains three input fields: "Material group:" with the value "free machining carbon steels, wrought", "Material sub-group:" with the value "Medium Carbon Leaded", and "Conditioning:" with a dropdown menu set to "Hot Rolled". Below these fields, it states "gives a hardness range of" followed by two input fields containing "125 BHn" and "325 BHn". At the bottom of this section is a button labeled "Use this RANGE of hardness values".

Figure 4.10: Material hardness dialogue box

The user may input a specific value of material hardness, if known, or alternatively select from a pick list of possible forms of surface conditioning (including a default choice of 'All Conditions'). Each type of surface conditioning generates a range of feasible hardness values. With each new form of conditioning selected, the specific value of hardness is set to the maximum hardness achievable for that conditioning state as this will tend to produce the most conservative cutting data, which is the safest default behaviour.

If the range of hardness values is selected, multiple cutting data solutions are generated for evenly spaced values (50BHn apart) of hardness across the range.

4.4 Real-time regression analysis of standard cutting data

Having placed a material within a consistent group of materials, a method is required for generating feasible starting cutting conditions. The most straightforward method would be to have a simple lookup table containing standard cutting conditions. A simple pattern matching algorithm could be used to find the set of cutting data that most closely corresponds to the material specified. Despite the simplicity of this approach, it suffers from a lack of fine control over the exact cutting conditions generated and is highly sensitive to the quality and coverage of the data held in the database.

The mechanical properties of a workpiece material have a critical effect upon machinability. Several authors have commented upon the relationship between machinability and surface hardness [Janitzky (1944), Jin & Sandström (1994a), (1994b)]. Indeed it is interesting to note that the machining data presented in the *Machining Data Handbook* [MetCut Research Associates (1980)], as shown in Table 4.1, is divided firstly by material conditioning and secondly by Brinell hardness.

As described in section 4.2, it is difficult to find consistent relationships between material properties and cutting characteristics for a large set of materials. However, if the material can be categorized in a small group of materials that exhibit similar machining responses then it is possible to relate material hardness to the typical cutting conditions. This analysis is performed by using multiple regression techniques to fit polynomial expressions to the stored data of cutting velocity and feed per tooth when related to material hardness (see Appendix D).

The data presented in the *Machining Data Handbook* is quoted for discrete ranges of material hardness, generally covering about 50 Brinell hardness units (see Table 4.1). In order to apply multiple regression techniques, a single value of material hardness is required to correspond with the associated cutting data. This single value may be selected from three different positions within the given hardness range: maximum

hardness, minimum hardness or average hardness. The selection of these hardness selection criteria affects the cutting data generated in the following ways:

- Maximum value** This assumes that the quoted cutting data applies to the material with the surface hardness at the top of the given hardness range. This will tend to produce the most aggressive cutting data.
- Minimum value** This assumes that the quoted cutting data applies to the material with the surface hardness at the bottom of the given hardness range. This will tend to produce the most conservative cutting data.
- Average value** This assumes that the sample cutting data applies evenly over the hardness range and therefore a single representative value of hardness is taken as being in the centre of the hardness range.

No precise material hardness values are presented in the *Machining Data Handbook*. In order to produce conservative data, the OPTIMUM system performs all regression calculations on the minimum hardness value within a hardness range, although this can be easily changed. A graph of a typical regression curves for a specific material group for each of the three aforementioned hardness criteria is shown in Figure 4.11.

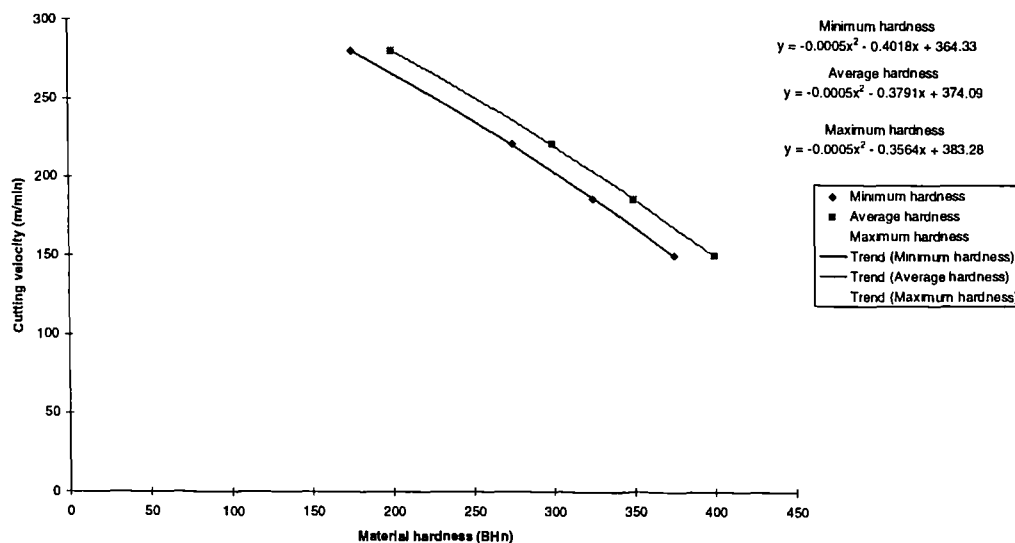

Figure 4.11: Polynomial curve fitting by multiple regression on cutting velocity against material hardness for machinability group 4 (free machining carbon steels, wrought - medium carbon resulfurized), finish facing.

All regression calculations are performed in real time and thus the generated cutting parameters always reflect the most recent state of all the data tables. A second order curve fit is applied to the cutting velocities related to material hardness.

Feed per tooth is calculated in a similar way but using a third order curve fit. This higher order polynomial is used because feed per tooth is often not varied in a continuous way and this tends to produce sets of discrete values of feed per tooth rather than a continuous range (as can be seen in the data tables extracted from the *Machining Data Handbook*). Thus a third order curve fit is more able to produce the stepwise relationship that can be seen in Figure 4.12.

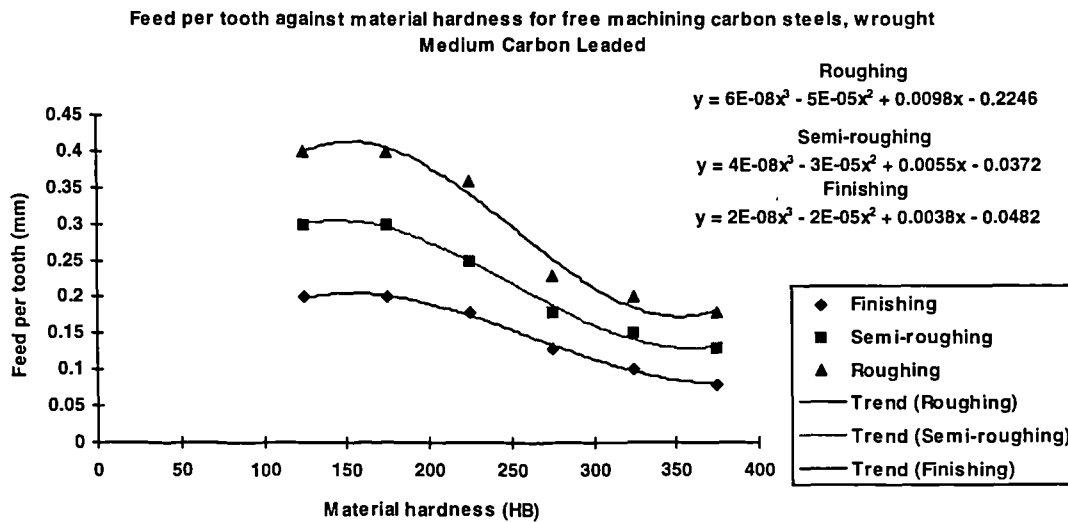

Figure 4.12: Graph of regression curves for feed per tooth against material hardness for visual feedback to user

A selection of graphs of regression curves for various material types is presented in Appendix E.

4.4.1 Data grouping for regression analysis

When using multiple regression it is important to use the most appropriate group of data for the analysis. The critical parameter is the number of independent points within the data set. If only two values of material hardness are available for a machinability group then it is only possible to fit a first order curve (a straight line) to the data. For the cutting velocity regression calculation, it is necessary to have at least three distinct values of material hardness and for the feed per tooth calculations at least four distinct values

are required. If this amount of cutting data is not available for the selected machinability group then the method examines the data for the material group that the machinability group lies within. Most material groups contain more than one machinability group and thus considering the standard cutting data for the material group is likely to yield more distinct values of material hardness. If the material group does not have enough distinct data then the calculation process ceases with an informative error message.

The current materials database contains only a few obscure groups of materials that do not contain enough cutting data for a meaningful regression analysis. However, this data set is merely intended to provide a starting point so that the system can function immediately in an industrial environment. An initial period of data collection is not required.

4.4.2 Visual feedback and verification of regression calculations

In the machinability assessment method, regression is used for the purpose of polynomial curve fitting. This technique regards all the data points as equally valid and thus even disparate data points are used to modify the final curve equation that is calculated. In order to increase user confidence and provide a further level of error checking the system provides extensive visual feedback of the regression calculations used to generate the starting cutting data. Graphs of the data sets used along with the calculated regression curves can be displayed for each of the regression calculations performed, as shown in Figure 4.12.

4.5 Using incomplete or partially defined input data

In order to gain significant exposure and acceptance in an industrial environment, it is critically important that any new decision support methods are flexible enough to accept a wide range of input data. It is likely that sometimes a full set of input data will not be available and, in this case, it is highly desirable that the method should still function, if possible, or fail in a graceful way, i.e. stop the procedure in a non-destructive way with full disclosure of the reasons for failure and options to continue with different input data. In addition to handling incomplete data, it is often also desirable to assist in the data entry process by presenting the user with the minimum number of choices required to fully specify any data set. This can be achieved by initially filling certain data fields with

reasonable default values. Also any input data that must be one of a discrete list of possible values (such as machine tool or available cutter) can be presented as a pick list so as to remove the possibility of invalid data input.

4.5.1 Defaults and reasonableness checking

OPTIMUM is designed to present reasonable default values for data input fields wherever possible. A good example of this is the specification of material hardness. A material is first categorized by either chemical composition, material group or standard designation. This information is used to search the standard cutting data tables to find all the possible forms of surface conditioning, along with maximum and minimum associated surface hardness values, as shown in Figure 4.10. In accordance with the data driven design methodology of the software, all the default values and pick lists are calculated in real time based on the contents of the main standard cutting data tables.

4.5.2 Rule firing with incomplete chemical composition data

Rule-based logic forms a powerful method for material classification. However, descriptions of material composition feature a long list of alloying elements, often in minutely small amounts. It is possible that a description of a material by composition obtained from either an analysis of the material or from a data source may not contain values for some of the trace elements.

Thus it becomes important to be able to evaluate a set of rules whilst only possessing incomplete input data. This is achieved by adding conditional statements to the evaluation logic so that a clause of a rule will only be fired if a specific value of the corresponding alloying element has been input, i.e.

```
IF <%element>0>
  AND <%element<%maxelement>
  AND <%element>%minelement>
  ...
```

This additional logic allows the widest variety of material chemical description to be evaluated and makes the overall method considerably more robust and able to absorb the small discrepancies in chemical composition that may be encountered.

4.6 Modification of suggested cutting data

The input and output data for the machinability assessor is shown in Table 4.6.

Input Data	Output Data
Operation details (operation type and dimensions)	Machinability group
Material type (chemical composition, material group or standard designation)	Depth of cut (mm)
Material surface properties (surface hardness or conditioning)	Cutting velocity (m/min)
	Feed per tooth (mm)
	Tool material (ISO tool grade)

Table 4.6: Input and output of machinability assessor

All the output of the assessor is stored in a data table and can be recalled at any time. The output data may be modified by the user in two ways: adjusting the depth of cut or selecting a specific insert grade.

4.6.1 Modification of axial depth of cut

It is possible to generate cutting data without a specific depth of cut. The user may specify the type of cut as roughing, semi-roughing or finishing which correspond to depths of cut of 8 mm, 4 mm and 1 mm respectively. As the machinability method is not designed for cutting data optimization or tool selection, all other operation dimensions are not required. However, the user is afforded the opportunity to alter the depth of cut and recalculate the initial cutting data.

As the standard cutting data is supplied for the aforementioned standard depths of cut a simple second order regression calculation is performed on interpolated values of cutting velocity for each of these standard depths, as shown in Figure 4.13. This can be a useful process in order to find the effects on the cutting data for different cutting depths or to refine the data suggested for a general operation type to be closer to the actual cutting depth found on the component.

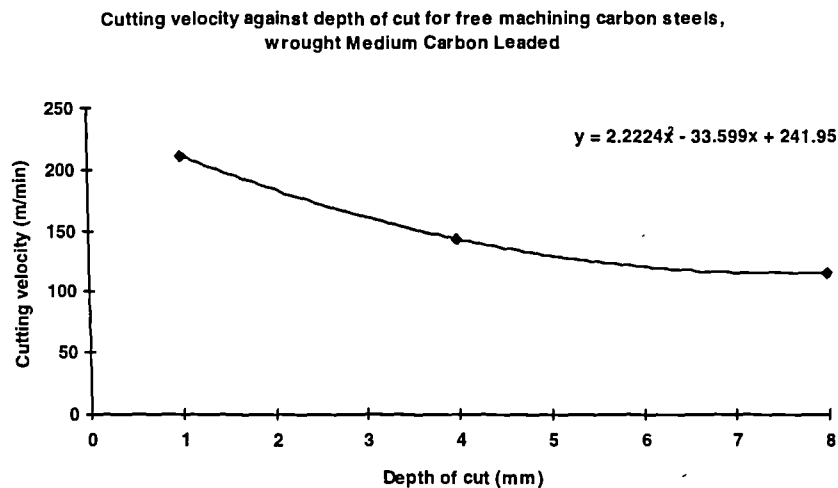

Figure 4.13: Multiple regression for interpolation of cutting velocity for a non-standard depth of cut

4.6.2 Modification of suggested insert grade

As there is no explicit tool selection function in the machinability assessor, exact tool specifications are not generated. Instead a generic ISO code of tool material is displayed. Most tool manufacturers categorize their tools with proprietary coding systems and it is generally possible to equate a particular insert material grade with an ISO application range.

The user may choose to modify the suggested cutting data to apply to a specific available insert grade. This is achieved by using a comprehensive data table that stores typical ratios of cutting velocity between all the possible combinations of insert grades. These ratios are generated from the standard cutting data presented in tool manufacturers' literature [Seco Tools AB (1994)]. A typical set of cutting velocity ratios is shown in Table 4.7.

Grade	T25M			S10M			S25M		
	F	SR	R	F	SR	R	F	SR	R
T25M	1.00	1.00	1.00	0.93	0.93	0.93	0.83	0.84	0.84
S10M	1.08	1.08	1.08	1.00	1.00	1.00	0.91	0.90	0.91
S25M	1.20	1.19	1.19	1.10	1.11	1.10	1.00	1.00	1.00

where F = Finishing, SR = Semi-Roughing, R = Roughing

Table 4.7: Ratios of cutting velocity for different insert grades for finishing facing, material group 1 (Free Machining Carbon Steels, Wrought)

Each insert grade stored in the grades database has associated ranges of applicability for the ISO P, M and K specifications (See Appendix F). The available inserts are scanned and the one that best fits the suggested ISO material grade is selected as the default.

As the data used to generate the initial starting cutting conditions is conservative in nature, it is assumed that this corresponds to the specific insert grade that would exhibit the lowest performance for the specified operation and workpiece material. The user is presented with a list of the feasible inserts grades and, as each one is selected, the cutting velocity is modified by the appropriate ratio. If a specific insert grade is selected then the modified cutting data is stored as a new results set.

4.7 Summary and discussion

The machinability assessor provides a highly robust and flexible method for generating initial cutting conditions from a wide range of input information. Tool manufacturers face increasing demands for a full range of product support including field trials, training courses and real-time technical support by telephone. The latter is possibly the most critical form of request for assistance and often involves technical issues like machinability of new materials as well as advice on the selection of tools and definition of cutting data. Small batch machinists or jobbing shops are frequently faced with new or not widely known workpiece materials (particularly alloys conforming to foreign standards) and they require feasible starting sets of cutting conditions.

It is critically important that the machinability assessment method is able to deal with any possible combinations of input data ranging from the highly specific (an exact material specification and heat treatment history) to the highly non-specific or incomplete (just a general material type with a type of surface treatment). This is achieved by a combination of data driven design, rule-based decision logic and statistical analysis. The user can receive graphical feedback to demonstrate the calculation method used to derive the suggested cutting data. The material classification method also performs a useful pre-processing function for the more detailed cutting data optimization and tool selection method described in the following chapter.

Chapter 5

Cutting data optimization and tool selection

This chapter describes the cutting data optimization and tool selection algorithm implemented in the OPTIMUM system. This method is designed to follow the material specification activity that forms part of the machinability assessment method described in Chapter 4. The cutting data optimization and tool selection criteria are highly configurable and implemented in a form that can be rapidly executed to allow tool selection to be carried out across a wide selection of possible tools (potentially the whole catalogue of tools from Seco Tools). This makes OPTIMUM compatible with the constraints of industrial application where a large number of tools is usually available during process planning. The overall functional layout of the algorithm is shown in Figure 5.1.

5.1 Process constraints

Whilst there is a wide range of possible values for the main cutting parameters, feasible cutting data are generally limited to a small section of the parameter search space. Various constraints act upon the cutting process, many of which are related to undesirable mechanical or thermal effects. The most critical constraints are geometric tool suitability, tool life, cutting forces, machine power, tool or workpiece deflection, chip capacity of a cutter, chatter and surface finish. The following sections present a brief discussion of each of these constraints followed by a description of the tool selection and cutting data optimization algorithm implemented in the OPTIMUM system.

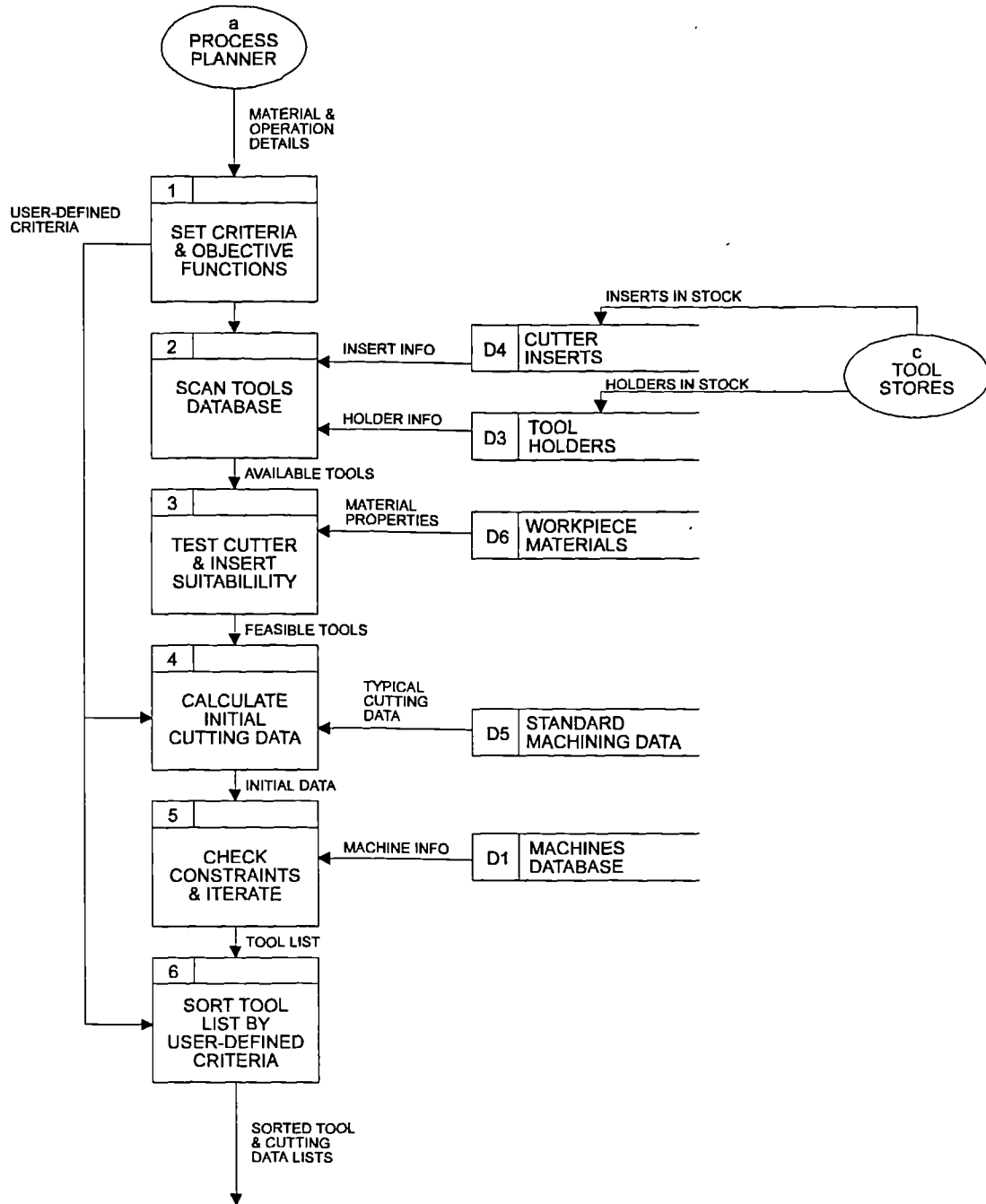

Figure 5.1: Layout of the cutting data optimization and tool selection algorithm

The process constraints implemented in the OPTIMUM cutting data optimization procedure are as follows:

1. Tool class suitability
2. Geometric tool suitability (tool diameter, approach angle, etc.)
3. Insert grade suitability
4. Chip evacuation suitability (cutter rake angles)
5. Tool height
6. Tool life
7. Harshness of chip thickness
8. Axial and radial depth of cut usage
9. Surface finish
10. Available spindle power
11. Available spindle speeds
12. Available range of table feed rates

The process constraints which are not currently implemented in OPTIMUM are:

1. Tool deflection
2. Workpiece deflection
3. Chip capacity
4. Chatter
5. Clamping force
- 6.

5.1.1 Geometric tool suitability

Despite the large amount of published research concerned with cutting data calculation presented in an abstract and mathematical form, it is important to apply this cutting data to a real cutting tool and, in particular, the most appropriate tool that is available. This leads to the need for an effective tool selection method coupled to a rigorous modelling of the cutting process.

Most of the characteristics that limit the applicability of a tool are of a geometric nature. It is crucial that the tool is of a suitable size and shape to perform the designated task. The geometric constraints on tool selection are:

1. The cutter must be able to fit into the machine tool. Many tools feature special taper attachments or arbors that create a longer overall effective tool length than when just using a cutter with an integral shank. Also the tool must not be too heavy to be used by the machine tool.
2. The tool must be of a suitable type for the operation i.e. it must possess cutting edges on the appropriate faces to produce the desired machined surfaces. Some operations can be achieved with a variety of types of cutter. For example, facing can be performed satisfactorily with a face cutter, square shoulder cutter or an end mill.
3. The tool must be of a feasible size and shape to produce the final operation geometry. For instance, a slotting cutter cannot be wider than the slot and a square shoulder cannot be produced with a cutter that does not have a 90° approach angle.
4. The cutting rake angles of the tool should be able to produce an effective chip breaking action according to the characteristics of the workpiece material.
5. The insert material grade and chipbreaker form, if present, should be of a type that will produce controlled chip breaking, satisfactory surface finish and acceptable tool wear. Although most modern insert grades are capable of cutting most hard engineering materials for a short cutting time, this is generally undesirable as grades are usually designed for specific ranges of materials.

All of these constraints are evaluated in the cutting data optimization and tool selection algorithm using the full range of cutter and insert information that is publicly available from cutting tool manufacturers. The main tools database contains the whole range of tools supplied by Seco Tools UK.

5.1.2 Tool life

Tool wear is generally regarded as undesirable and should be minimized for an efficient rate of metal removal. The mechanisms by which a cutting tool wears and the prediction and control of tool life has been a major field of interest throughout the history of metal cutting.

Tool life is influenced by a number of variables. The length of cutting time available before a tool has worn out is often represented as a function of various tool, material and operation parameters. These parameters include cutting conditions such as the tangential cutting velocity and feed per tooth, tool geometry details such as tool diameter, number of teeth and the various rake angles, the geometry of the engaged portion of the tool, the combination of workpiece and tool material and various shock effects caused by the intermittent nature of the cutting process.

However not all these variables exert the same degree of influence on the tool life. Since the earliest metal cutting research it has been recognized that the cutting velocity is critically important when related to tool life. Indeed, Taylor (1907) derived the equation that still bears his name relating cutting velocity to tool life in the following form:

$$vT^n = C \quad (5.1)$$

where v is the tangential cutting velocity (m/min), T is the tool life (min) and n and C are constants that depend on both the workpiece material and the tool material.

For turning, this equation is only valid for a given feed and depth of cut. In order to include these independent variables the 'Extended Taylor's Equation' has become widely used:

$$T = \frac{C_2}{v^\alpha s_z^\beta a_u^\gamma} \quad (5.2)$$

where a_u is the axial depth of cut (mm), s_z is the feed per tooth (mm) and C_2 , α , β and γ are all constants depending on the workpiece and tool materials.

The Extended Taylor's Equation does present some problems when applied to milling, as opposed to turning. Many of the process parameters referred to in turning are not simply defined for milling. 'Feed' can be table feed, feed per revolution or feed per tooth. In milling the instantaneous chip thickness is not constant with relation to time. In order to overcome this difficulty, Yellowley and Barrow (1978) examined the concept of 'equivalent feed rate', s_{eq} , which is a function of the feed per tooth, s_z , and the engagement angle, ϕ_s , defined by the following equation:

$$s_{eq} = \frac{s_z}{\phi_s} \left(\frac{\phi_s}{2} - \frac{\sin(2\phi_s)}{4} \right) \quad (5.3)$$

For milling, the depth of cut can be measured in several directions, most commonly axially (a_a) or radially (B). There can also be some ambiguity about what is meant by the term 'tool life'. This can be taken to refer to the active tool life (i.e. the time that the tool would last if it were cutting continuously) or the actual tool life (i.e. the total elapsed time from first engaging the workpiece until the tool wears out).

It has been reported that other variables have been found to influence tool life. Some of these are related to the thermal and mechanical shock that the tool experiences when entering and exiting the cut. Yellowley and Barrow (1978) propose the addition of a new parameter to the extended Taylor's equation that represents thermal fatigue effects as follows:

$$T = \frac{C_3}{v^\alpha s_z^\beta a_a^\gamma X^\epsilon} \quad (5.4)$$

where X is the thermal fatigue parameter and C_3 and ϵ are constants related to the tool and workpiece material.

Since the thermal fatigue parameter is related to the time spent in and out of the cut, it can be expressed as a function of cutting velocity, cutter diameter and engagement angle. Thus an expression for active tool life in terms of the independent cutting variables can be derived from equation 5.4 in the following form [Lau (1991)]:

$$T_{active} = \frac{C_4 \phi_s^{\alpha_2} D^{\alpha_3}}{v^\alpha s_{eq}^\beta a^\gamma} \quad (5.5)$$

where α_2 , α_3 and C_4 are constants depending on the workpiece and tool materials.

The ratio between the total elapsed tool life and the active tool life is the same as the ratio between the revolution period and the time in-cut per revolution. Thus:

$$\frac{T}{T_{active}} = \frac{2\pi}{\phi_s} \quad (5.6)$$

Combining equations 5.5 and 5.6 gives:

$$T = \frac{2\pi}{\phi_s} \frac{C_4 \phi_s^{\alpha_2} D^{\alpha_3}}{v^\alpha s_{eq}^\beta a^\gamma} \quad (5.7)$$

Unfortunately, in order for equation 5.7 to be useful for tool life prediction purposes it is necessary to have a method for finding values of the material specific constants C_4 , α , α_2 , α_3 , β and γ . To find values for these six constants for every likely combination of tool material and workpiece material (and possibly cutter type) would require a large number of example data sets that included variations in all of the independent variables in equation 5.7. This is not feasible as most published data tables do not include the exact cutter diameter and complete details of the engagement conditions. Sets of cutting data for specific cutter types and insert grades are available from tool manufacturers' documentation [Sandvik Coromant (1985), (1991), Seco Tools AB (1993), (1994)]. Thus, to facilitate the greatest range of applicability and ease of recalculation of the critical constants, a simplified extended Taylor's equation is proposed as follows:

$$T = \frac{C_1}{v^\alpha s_{eq}^\beta} \quad (5.8)$$

5.1.3 Cutting forces

It is important to be able to evaluate the cutting forces at the tool tip in order to place constraints on the cutting parameters relating to strength of workholding, deflection of tool or workpiece and the power required to maintain the cutting action. The resultant force that acts on the cutting tip is generally split into three orthogonal component directions that rotate with the tool - radial, tangential and axial.

There are many methods of evaluating cutting forces mentioned in published literature. Lau (1987) presented a review of these publications. Simple cutting force predictions may be made by utilizing the concept of specific resistance to cut, k_{sm} (also called specific cutting force). This may be defined as the typical force required at the tool tip to create a chip with a cross sectional area of 1 mm^2 . Experimentally derived values of k_{sm} are available for some materials in engineering handbooks and some tool manufacturers present methods for calculating a suitable value for a set of broad material groups and including some tool geometry characteristics.

Bouzakis and Methenitis (1985) propose a refinement of this concept to include specific resistance values for each of the major force axes. Thus the cutting force components are proportional to the cross sectional area of cut as shown:

$$\begin{aligned} F_{tang} &= k_{sm.tang} ah \\ F_{rad} &= k_{sm.rad} ah \\ F_{axial} &= k_{sm.axial} ah \end{aligned} \quad (5.9)$$

where $k_{sm.tang}$, $k_{sm.rad}$ and $k_{sm.axial}$ are the specific resistance to cut in each of the force directions.

The specific cutting forces in equation 5.9 are shown to be dependent on the chip thickness in the following way:

$$\begin{aligned}k_{sm.tang} &= C_{tang} h^{E_{tang}} \\k_{sm.rad} &= C_{rad} h^{E_{rad}} \\k_{sm.axial} &= C_{axial} h^{E_{axial}}\end{aligned}\tag{5.10}$$

where E_x are exponents primarily related to the workpiece material and C_x are constants related to the tool and workpiece material, cutter geometry and engagements angles.

Unfortunately, as with many of the constants in the enhanced tool life equations described in the previous section, most of these constants and exponents are not available for a wide range of materials and cutter geometries. The experimental work required to find these values for even a fraction of the tools in the tools database of OPTIMUM would be prohibitively expensive in terms of both time and materials and is beyond the scope of this research.

Although it is important to realise that the individual cutting force components can vary greatly, the only specific cutting force generally available is the overall resistance to cut, k_{sm} . Thus, the cutting force calculations implemented in OPTIMUM are just concerned with finding the total resultant cutting force.

5.1.4 Machine power

The power required to remove a volume of metal is a function of the force required and the velocity at which the material is removed. The velocity in the axial direction is generally zero and the radial velocity is usually negligible when compared to the tangential velocity. Thus the cutting power required may be expressed as a function of the resultant cutting force and the cutting velocity:

$$P_{cut} = F_{total} v\tag{5.11}$$

where P_{cut} is the cutting power (W) and F_{total} is the total resultant cutting force (N).

The resultant cutting force is a function of the area of material removed and the specific resistance to cut of the workpiece material:

$$F_{total} = k_{sm} a_u h \quad (5.12)$$

where h is the instantaneous chip thickness (mm).

Combining equations 5.11 and 5.12 and simplifying gives an expression of required power in terms of specific resistance to cut and metal removal rate of the form:

$$P_{cut} = \frac{k_{sm} m}{60} \quad (5.13)$$

where m is the metal removal rate (mm³/min).

5.1.5 Tool and workpiece deflection

Deflection of the cutting tool can produce deformed workpiece geometry and undesired dimensions. To produce a dimensionally acceptable component, tool deflection must be within tolerance limits, assuming a perfectly rigid workpiece.

Many cutters with short shanks or wide clamping surfaces, such as facing and square shoulder cutters, are regarded as sufficiently stiff to not generate significant surface errors due to tool deflection. Longer and more slender shank type cutters may be more susceptible to deflection. Surface errors in peripheral milling will be produced by tool deflection caused by forces in the Y direction, perpendicular to the feed direction (see Figure 5.4).

It is possible to analyse the tool as a simple cantilever beam rigidly supported by the tool holder and acted upon by a point force which is the resultant of all the cutting forces in the Y direction. Such an analysis requires certain simplifications to be made about the tool geometry. The second moment of area of a helical cutter is not equivalent to that of a cylinder of a similar diameter, so empirical scaling factors may need to be derived and applied.

Tool deflection is not implemented in this algorithm for several reasons. Modern tooling design has produced rigid tools and refined tooth spacing that can significantly reduced the likelihood of tool deflection becoming an active constraint. Also, a full consideration of tool deflection as a constraint requires a exact description of the tool geometry. Finally, most cutting data optimization system operate in an iterative fashion and a deflection analysis of a complex geometry such as a tool may be prohibitive in terms of computing time.

The interaction between the tool and the workpiece defines the achievable accuracy of the final part. Workpiece deflection can constrain the cutting conditions in cases where parts of the workpiece are particularly thin. This is especially true for components with thin wall sections such as those commonly found in the aerospace industry. The wide range of workpiece geometries encountered in milling mean that a full solid model of the workpiece would be required to generate useful workpiece tolerances.

In order to fully implement workpiece deflection as a constraint it is necessary to rapidly evaluate the influence of a point or distributed load (from the tool) on the workpiece material surrounding the tool. This can most readily be achieved by using finite element analysis. Whilst modern microcomputers are capable of rapidly performing complex calculations on large sets of data, there are still considerable complications associated with this method, particularly regarding automatic mesh generation. Also the amount of computing time required on common computer hardware is still substantial and thus not ideally suited to an automatic tool selection procedure. An effective workpiece deflection model would require extensive integration between the tool selection system and a solid modelling package that can handle the workpiece geometry and interface with a finite element package. This would also open up possibilities for further interrogation of the workpiece geometry by the cutting data optimization and tool selection method. A complete solid model of the product and the associated interfaces should be a capability of any modern process planning system. However, a tool selection system of a tool manufacturer will generally not have access to full geometric descriptions of a customer's components.

It was concluded that an interface with a solid modeller was not appropriate for the current implementation of the OPTIMUM system. Thus, at this early stage of software development, workpiece deflection is not included as a constraint.

5.1.6 Chip capacity

The interrupted nature of cutting in milling means that the problem of chip breaking is much less serious than that found in turning. However, the volume of chips that can be produced within the swept length is limited because chips may become trapped within the chip pockets of the cutter. The amount of material that can be removed in one rotation by a given cutter is referred to as chip capacity. The chip capacity of a given cutter can be compared with the chip volume produced by the current cutting parameters of axial depth of cut, radial depth of cut and feed per tooth, as shown in Figure 5.2.

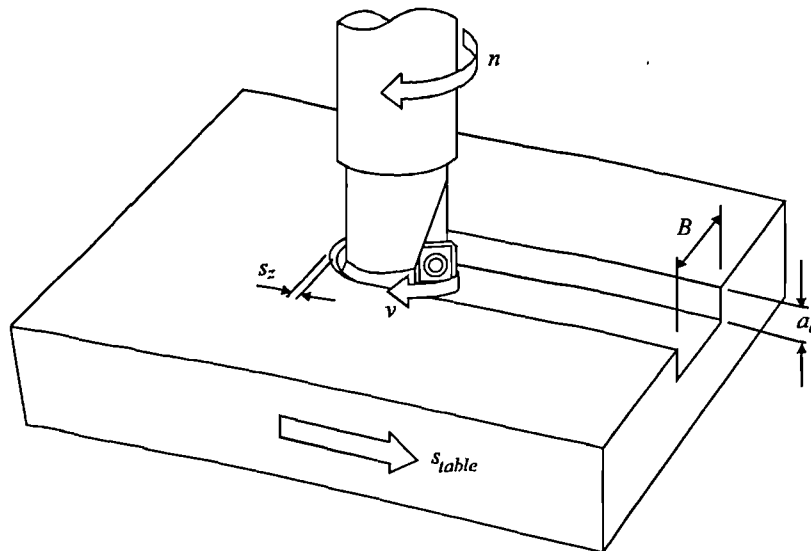

Figure 5.2: A typical milling operation (after Seco Tools AB, 1994)

It can be shown that the volume of chips produced in one revolution of the cutter is given by the following expression:

$$CV = a_a B s_z \quad (5.14)$$

where CV is the chip volume (mm^3) and B is the radial width of cut (mm).

Possibly the simplest method of assessing the maximum available chip capacity is to calculate the volume of the pocket on the cutter between its teeth. Often this value will be far from the actual chipping capacity available due to several other factors that influence the form of chipping. One of the most important factors is the type of workpiece material. Brittle materials, like cast iron, tend to produce short, broken chips while more ductile materials such as some steels and aluminium alloys produce longer, curled chips. A greater volume of the first type of chips will be able to be accommodated in a chip pocket than the second type of chip. The volumetric expansion of the chip caused by its curved shape means that it is not possible to fill the chip pocket completely so any limiting value of chip capacity must be considerably less than the actual volume of the pocket. One solution to this problem would be to multiply the pocket volume by a constant that is less than unity and is a product of the material type. However, the shape of the chips produced is also affected by the cutting conditions and, in addition, it may be useful to evaluate the instantaneous chip shape and use this to modify any chip capacity multiplier accordingly.

The second important factor affecting chip capacity is the geometry of the cutter. The axial and radial rake angles determine the general direction that the chips are guided away from the cutting edge (see Appendix I for an description of the cutter rake angles). For instance, a positive-negative cutter (positive axial rake and negative radial rake) will tend to guide the chips up and away from the chip pocket thus providing an effective chip capacity that is greater than the actual pocket volume. A positive-positive cutter would also guide the chips upward away from the cutting edge but also towards the centre of the tool i.e. into the pocket. In terms of chip evacuation, the worst tool geometry is a negative-negative cutter where chips would tend to flow downwards and inwards, towards the cutting edge. In this case, the chipping pocket will define the chip capacity, regardless of other effects.

The overall diameter of a cutter will also affect the chip capacity to a lesser degree as a small diameter cutter will deform the chip more than a larger diameter cutter for a similar radial depth of cut [Enparantza (1991)]. Cutting fluid can influence the flow of chips and compressed air can be used to continuously evacuate the chip pockets on a cutter.



In summary, there are several factors, mostly of a geometric nature, which affect the chip capacity of a tool. Unfortunately there is little published analysis available about implementing chip capacity as a process constraint. The current catalogues and technical documentation of the major tool manufacturers [Sandvik Coromant (1991), Seco Tools AB (1993), (1994)] do not present any guidelines regarding chip capacity being an active constraint on the cutting data. However, there are some available guidelines for cutter selection that include suggestions for appropriate cutter geometries for various areas of application [Sandvik Coromant (1985)]. Chip formation is influenced by material properties and the selection of suitable axial and radial rake angles on a cutter can produce significantly enhanced chip control. For instance, the following cutter rake angles are suggested for face milling:

Area of application	Axial rake	Radial rake
General face milling (Not for very hard materials)	+7°	+2°
Face milling with small machines (Not for hard materials or heavy feeds)	+19°	+9°
Heavy duty face milling (Not cost efficient for light machining)	+12°	-8°
Face milling of hard materials (Increased power and tool loading)	-6°	-7°
Face milling aluminium alloys	+15°	+15°

Table 5.1: Cutter geometry selection guidelines

These suggested rake angles are affected by the type of chips encountered and also by the strength of cutting edge that is required. A negative-negative cutter presents the strongest geometry to support the cutting edge on the insert. Nevertheless, many other sources of published data and CAPP systems suggest that other constraints will become active before chip capacity becomes critical. Until a more comprehensive analysis becomes available, chip capacity will not be implemented as a constraint as it is assumed that a cutter has sufficient chip capacity for the cutting action with the most aggressive cutting parameters possible for that tool/workpiece material combination. User defined recommendations for material dependent cutter rake angles are implemented in the OPTIMUM system.

5.1.7 Chatter

During the cutting process, the workpiece can be deformed by forces generated in several different ways [Koenigsberger & Tlusty (1970)]:

1. Weight forces
2. Cutting forces
3. Forced vibration
4. Self-excited vibration

These four modes of force induced deformation produce different constraint criteria for the cutting conditions. It has been suggested that if the criteria for mode 4 are satisfied then the other three are generally also satisfied.

Koenigsberger & Tlusty (1970) present a simple diagram of the mechanism of self-excited vibration in metal cutting, as shown in Figure 5.3. The two parts of this mechanism are the cutting process and the vibratory system of the machine tool. It may be explained in the following way. The cutting forces generated at the tool tip generate a deformation in the machine structure which modifies the distance between the tool tip and the workpiece. This alters the chip thickness and, consequently, the cutting forces are altered leading to a new, different deformation and displacement of the cutting edge. This system can become unstable under certain conditions and there is often a clearly defined boundary between the stable and non-stable regions.

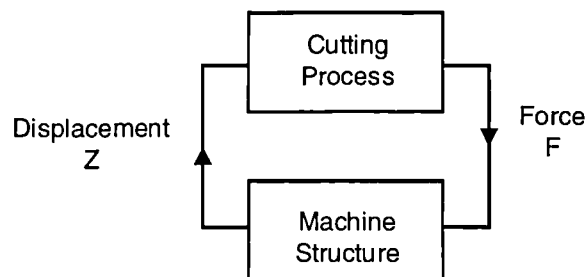

Figure 5.3: Chatter closed-loop mechanism

Chatter is a constraint that is generally not considered in cutting data optimization procedures. There are probably two main reasons for this: the complex nature of the self-

excited vibration mechanism and the fact that, for modern machine tools, it is unlikely to be a problem after all other constraints have been considered. If it is assumed that the spindle and the tool clamping system are sufficiently stiff then the simplest way to eliminate chatter as an active constraint is to select the stiffest tool available.

It has been proposed that chatter can be the limiting factor with regard to selecting the radial width of cut [Yellowley & Gunn (1989)]. This assumes that the axial depth of cut is such that this does not cause the chatter limit to be exceeded. However, no guidelines are presented for choosing a suitable axial depth of cut. It appears that the optimization algorithm given can only be fully applied where extensive knowledge of the performance and vibration characteristics of the machine and the tools being used is available.

Enparantza (1991) includes an implementation of an active chatter constraint method in a cutting data optimization and tool selection system developed at UMIST. The limiting radial depth of cut is presented in two ways:

$$B_{lim} = \frac{-1}{2rG_{min}} \quad (5.15)$$

where B_{lim} is the limiting value of the radial width of cut (mm), G_{min} is the minimum value of the real part of the cross receptance (mm/N) and r is a dynamic cutting force coefficient (N/mm²)

Enparantza's optimization program includes a limiting velocity corresponding to the minimum wavelength for each tool of the following form:

$$v_{char} = \left[\frac{2\pi 60}{1000} \right] f_n \lambda_{min} \quad (5.16)$$

where f_n is the natural frequency (Hz) and λ is the vibration wavelength (mm).

This form of analysis is admirably comprehensive but suffers from one major drawback that has already been mentioned with regard to other constraints; it is difficult to apply to a broad based tool selection system due to a shortage of available data regarding chatter behaviour for a range of common machine tools, workpiece materials and milling

operations. Effective analysis of chatter requires extensive testing on a specific machine to ascertain certain vibration characteristics of the machine structure. Clearly the time and cost required for such tests is not appropriate in the context of a tool selection procedure for remotely supporting tool customers. Also, any requirement for these complex vibration parameters is unlikely to be fulfilled by machine tool users who are most concerned with achieving satisfactory cutting conditions with a minimum of investigation and experimentation. It is to be hoped that modern machine tools can offer rigid workpiece holding and tool clamping. Ongoing research has produced several working systems for on-line chatter control, often employing acoustic emission sensing to detect the onset of chatter and alter the cutting conditions in real time [Smith & Delio (1992)]. However, due to the aforementioned limitations of applicability, chatter is not currently implemented as an active constraint in this cutting data optimization algorithm.

5.1.8 Surface finish

The level of surface finish achieved in milling is a function of marks left on the workpiece by the cutting edges of the cutter. There are two main types of irregularity found on a machined surface: roughness and waviness [Shaw (1984)]. Waviness is a more widely spaced irregularity than roughness, being caused typically by movement of the workpiece or fixture, or vibration caused by the cyclic increase and release of cutting forces (often exacerbated by the formation of a built-up edge on the cutting edge).

Roughness is caused by the actual cutting process and the theoretical roughness value is given as a function of the cutter geometry and the feed per tooth. For peripheral milling the theoretical roughness on the aa surface (see Figure 5.4) is given by [Martelotti (1945)]:

$$rha = \frac{s_z^2}{8 \left(R \pm \frac{s_z z}{\pi} \right)} \quad (5.17)$$

where rha is the peak to valley roughness (mm), z is the number of teeth on the cutter and R is the radius of the cutter (mm).

In equation 5.17, the denominator has a (+) for up milling and a (-) for down milling. As the difference between the two milling modes is small, equation 5.17 can be approximated to:

$$R_a \cong \frac{s_z^2}{32R} \quad (5.18)$$

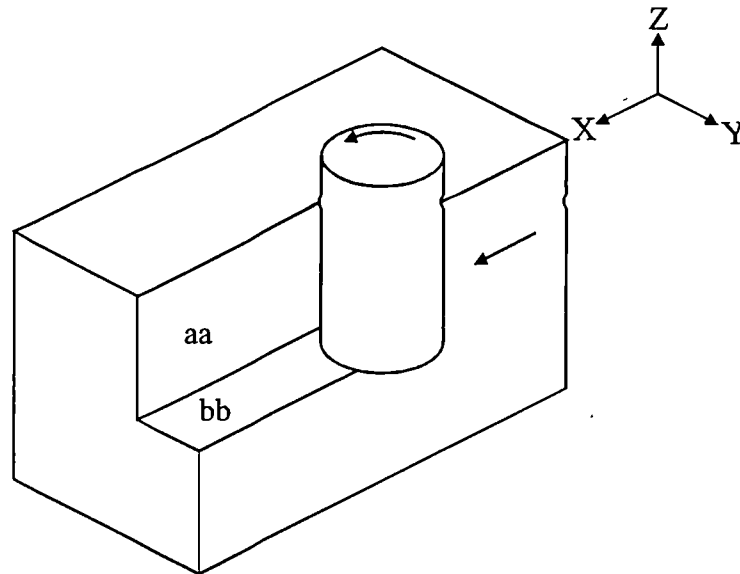

Figure 5.4: Surfaces generated by a milling cutter

In practice, the bb surface (see Figure 5.4) will be determined by the lowest positioned inserts. If the inserts have a nose radius then the maximum possible feed per tooth to achieve the specified surface finish, R_a , is given by [Radford & Richardson (1980)]:

$$s_z = \left(18R_a r_e \sqrt{3}\right)^{\frac{1}{2}} \quad (5.19)$$

If the inserts used feature a parallel land or a wiper blade is used then a very good surface finish can be achieved if the feed per revolution is limited to the length of the parallel land:

$$s_n < B_L \quad (5.20)$$

where s_n is the feed per revolution and B_L is the length of the parallel land of the insert (mm).

5.2 Multiple operation tool selection

Often the cutting data optimization and tool selection routine is only executed once for each workpiece feature being considered. However, there are two cases where the routine must be executed more than once. The first of these cases is where the specified feature is can only be achieved with more than one milling operation and therefore two tools are required. Thus the tool selection routine is executed twice and two different tools are selected. The second case occurs for semi-closed or closed operations where the first lateral pass involves plunging the cutter radially through the workpiece. The engagement angle for this first pass must, by necessity, be 180° . Subsequent passes may be made with a smaller engagement angle so as not to cut with the edges of the cutter width. Thus the cutting data optimization routine is executed twice for the same tool; once for the initial full width immersion pass and once for the evenly spaced subsequent passes.

5.2.1 Feature splitting

Many user-defined 'features' can be simply produced with a single machining operation involving a single tool. Examples of these operations include faces, square shoulders, slots, chamfers, through holes and simple rectangular pockets. However there are some more complex operations that are conveniently described as one 'feature' but generally require more than one machining operation. An example of such a composite feature is a T-slot. These are most commonly found in machine tool manufacture and they require special T-slotting cutters with a narrow neck and cutting edges on a shallow cylindrical section on the end of the tool. T-slotting cutters do not have active cutting edges on the neck section and thus an initial straight slot is required to allow the neck to pass through the workpiece whilst the end of the cutter removes the wide lower part of the T-slot. Thus a T-slot feature can be decomposed into a slotting operation and a T-slotting operation, as shown in Figure 5.5.

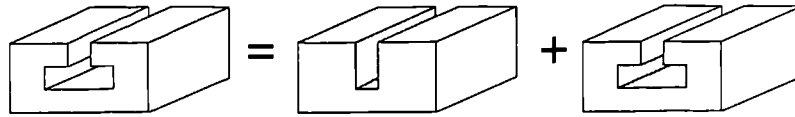

Figure 5.5: Decomposition of a T-slot feature into a plain slotting operation and a T-slotting operation

The OPTIMUM tool selection method decomposes T-slots into these two operations and performs a full cutting data optimization and tool selection procedure on each. Therefore, two sorted tool lists are generated for each specified T-slot.

5.2.2 Uneven distribution of radial width of cut between passes

The cutting data optimization routine described in this chapter attempts to produce cutting data for equally spaced axial and radial passes. It is undesirable to use the full width of a milling cutter in the cut as the chip thickness tends towards zero at the edges of the cutter. However, for some closed or semi-closed operations, such as slots and pockets, the first transverse pass must be made with the cutter fully engaged in the material. Once this first pass has been completed, there is sufficient space to allow subsequent passes to be performed with a more desirable radial width usage, as shown in Figure 5.6.

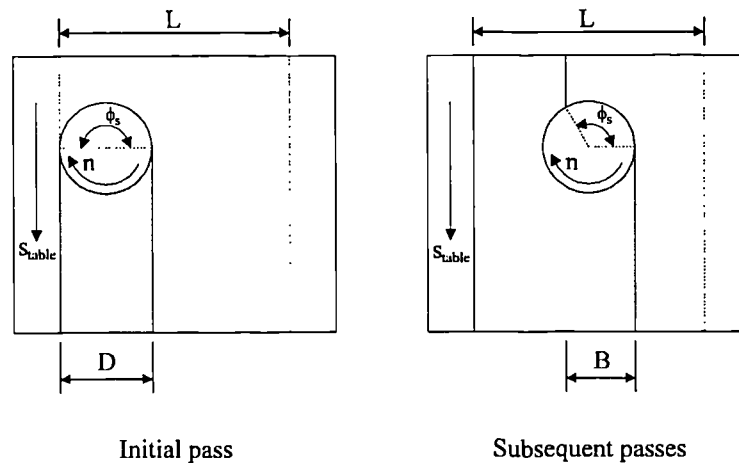

Figure 5.6: Uneven distribution of radial width of cut for a multipass slotting operation

The cutting data optimization procedure is run twice for these operations, the first time with an engagement angle of 180° and the second time with a floating number of radial passes. The initial plunging pass tends to produce more conservative data and the

subsequent passes can be achieved at a higher metal removal rate due to the reduced number of teeth in the cut at any moment.

5.3 Cutting data criteria

Most of the criteria used in the cutting data optimization method can be set by the user in a comprehensive dialog box which is available when initiating the tool selection module of OPTIMUM. The user defined criteria are:

1. Maximum and minimum radial usage of the cutter

For multi-pass facing, shouldering or slotting operations it is necessary to set a maximum and minimum radial usage for the second and subsequent passes. Typical values for these limits are 75% and 25% respectively.

2. Percentage of cutter cost to amortize across each operation

For effective cost calculations it is necessary to amortize the cost of the cutter across a number of operations representing the useful life of the cutter. This can be set by the user in order to vary the influence of the cost of the cutter on the optimization process. With careful use, most modern cutters can last for a large number of operations, so this percentage amortization cost is likely to be less than 1%.

3. Harshness of cutting data

The overall method of cutting data calculation described in this chapter is of a well-known general structure. The major cutting parameters are set according to the active constraints and criteria in order of decreasing influence on tool life. Thus, the first parameter to be set is depth of cut (axial and radial), followed by feed per tooth. The objective function can then be reduced to a simple form that can be solved to give the final variable, cutting velocity. The depths of cut are derived from the operation geometry. The initial feed per tooth is calculated from the maximum achievable chip thickness for the cutter. This can often produce very aggressive parameters so the user can define the harshness of this initial calculation. The harshness is defined as a percentage where 0% will give conservative standard data and 100% will produce data with the highest achievable chip thickness for the given cutter.

5.3.1 Cutting data objective functions

The objective functions of the cutting data optimization procedure are all based on analysis of the extended Taylor's equation for tool life as given by equation 5.2. The three cutting data objective functions are minimum cost, maximum production rate or constant tool life. The derived expressions of expected tool life for each of the objective functions are as follows:

Minimum cost:

$$T_{exp} = (\alpha - 1) \left(\frac{xt_3 n_i + y}{x} \right) \quad (5.21)$$

Maximum production rate:

$$T_{exp} = (\alpha - 1) n_i t_3 \quad (5.22)$$

Constant tool life:

$$T_{exp} = constant \quad (5.23)$$

Derivations of equations 5.21 and 5.22 are given in Appendix G. Thus, the severity of the cutting data generated is influenced by the choice of objective function and also the harshness level specified by the user.

5.4 Tool selection criteria

The automated selection of tools for machining operations can be achieved in several ways. The set of available tools may be searched and the first tool found that is capable of performing the given operation may be selected. Indeed, in industry tools are often selected purely on a geometrical basis without any assessment of cutting performance. Alternatively, a set of rules and heuristics may be used to sort the available tools by more complex criteria in order to select a tool that reflects as many user-defined objectives as possible. Lastly, a complete cutting data calculation and optimization may be performed

for every available tool and the resulting list of feasible tools and associated cutting data can then be sorted according to a user specified objective function. The first tool in the sorted list will be the one selected. This method possesses the advantage that each sub-optimal tool has a uniformly generated set of cutting parameters that can enable more complex selection procedure than just picking the top tool in the list.

It is this method of generating an exhaustive list of possible tools with associated cutting parameters and then sorting this list by user-defined criteria that is used in the tool selection method of the OPTIMUM system.

5.4.1 Tool selection objective functions

In order to select the most suitable tool for an operation it is necessary to define a method of evaluating the 'goodness' of each feasible tool that is available. There are several desirable conditions that can be used to show that a tool and its associated cutting parameters are particularly suitable for a given operation, such as maximum metal removal rate, maximum tool life, minimum overall cost or minimum overall time.

Whilst many CAPP systems select tools based upon just one such criterion, it is more likely that the tool selection problem in an industrial setting will be driven by a combination of criteria, each with a different degree of importance. Agapiou (1992a) suggests that a compound form of objective function may be formed by summing the weighted and normalized values of several criteria. Applying this approach to the aforementioned criteria gives a weighting function for a tool and its cutting parameters of the following form:

$$w_{rank} = \left(\frac{m}{m} w_m \right) + \left(\frac{T}{T} w_T \right) - \left(\frac{C_{total}}{C_{total}} w_c \right) - \left(\frac{t_{total}}{t_{total}} w_{time} \right) \quad (5.24)$$

where $\overline{expression}$ is the average value of expression for the current tool list, w_{rank} is the ranking weight, T is the nominal tool life (min), C_{total} is the total operation cost (£), t_{total} is the total production time (min) and w_m , w_T , w_c and w_{time} are the user defined sorting weights for metal removal rate, tool life, total cost and total time respectively.

Each parameter in equation 5.24 is normalized by dividing by the average value of the parameter for the current tool list. The normalized value is then multiplied by a user-defined weighting factor that allows the user to define the relative importance of each criterion. The parameters that are required to be maximised (MRR and tool life) are added whilst the parameters that are to be minimized (cost and time) are subtracted. Equation 5.24 is used to generate a weighting value for each tool in the tool list that is then used to perform a simple numerical sort on the tool list. The tool that appears at the top of the selected tool list is the initial suggested tool from the system (other, suboptimal tools may be suggested if the variety reduction module, described in Chapter 6, is used).

5.5 Cutting data optimization and tool selection algorithm

This section describes the algorithm for calculation and optimization of cutting data, followed by the user-defined tool selection procedure. Whilst it is quite possible to implement this algorithm by hand, the large number of possible cutter and insert combinations combine with the iterative optimization procedure to make this an impractical task. However it is ideally suited to realisation in software form. The cutting data algorithm is of an iterative form and is applied to each of the available and feasible tools to produce a list of possible tools and associated cutting data. The algorithm contains four main procedures:

1. Cutter and insert suitability checking
2. Evaluation of the initial cutting parameters
3. Optimization of the cutting parameters
4. User-defined tool sorting

The following four sections describe these procedures and present a complete description of all the checks and calculations performed in the tool selection module.

5.5.1 Cutter and insert suitability checking

Each tool in the main tool database has a set of parameters attached to it that can be used to evaluate its suitability for a given operation. All the data stored in this data table is derived from freely available information, the main source being the manufacturer's tool

catalogues and technical documentation [Seco Tools AB (1993), (1994)]. The following sections (a) to (h) describe the various checks performed on the cutter and insert to assess suitability for the given operation.

(a) Select the cutter

The only tools considered are those in the database marked as 'Available'. Thus a wide range of tools may be held in the main tools database but only those currently held in stock will be considered for tool selection purposes. For a manufacturing cell or machining centre there may be a reduced core set of tools from which to choose.

(b) Test holder suitability for the machining operation

All the tool holders stored in the tools data table of OPTIMUM are assigned a general class description derived from tool manufacturers' catalogues. Typical classes are "Face Mill", "Square Shoulder", "End Mill" and "T-Slot". In addition, each cutter body has a list of single character codes that show what operations it can be used for. The current set of codes and operations are shown in Table 5.2.

Code	Operation	Code	Operation
F	Face	H	Threaded hole
Q	Shoulder	R	Radius
D	Drilled hole	O	Profile
S	Slot	L	Plunge
C	Chamfer	U	Through pocket
P	Pocket	E	Closed slot
T	T-slot		

Table 5.2: Operation types and associated character codes

Table 5.3 shows some combinations of operation codes which are applied to some typical cutter types from the Seco catalogue. The application codes for each cutter are derived from the Seco Milling Technical Guide (1994).

Part number	Description	Codes
R215.49-1609.3-06	45 deg. chamfer cutter, D=9	C
R220.79-0063-16	90 deg. Plunging cutter D=63mm	DL
R216.19-2525.0-09/220	End mill/drill, D=25	DSPOU
R220.13-0100-12	45 deg. face mill, D=100	F
R220.17-0125	Sq. shoulder face mill, D=125	FQS
R220.29-0040-06	Button insert face mill, D=40	FR
R396.18-3236.3-40	Thread end mill, D=36	H
R218.19-05050.080-115	MT5 ball nose end mill, D=50	P
R217.29-3230.3-10	Button end mill, D=30	PR
R335.18-250.1418.60R	RH side & face mill, D=250	QSF
R417.19-2018.3-06	Spot facing end mill, D=18	SF
R215.59-03020.020-06	MT3 helical mill, D=20	SO
R217.69-3240.3-16G	Slot/end mill, D=40	SPO
R395.19-3240.4-18	T-slot mill, D=40, a=18	T

Table 5.3: Typical operation codes for milling cutters

(c) Test critical dimensions of the cutter

There are several checks that can be performed on the cutter geometry to establish its suitability for a given milling operation. The radial width of the cutter can be limited in several ways. The cutter diameter (D) is often constrained by the minimum width of the operation, such as the width of a slot, as shown in Figure 5.7.

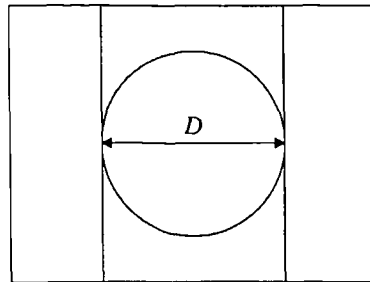

Figure 5.7: Maximum cutter diameter constraint for slotting

For pockets and closed slots, the radius of the cutter (R) is constrained by the corner radius of the operation, as shown in Figure 5.8.

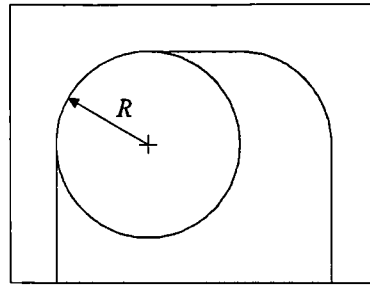

Figure 5.8: Maximum cutter radius constraint for pocket milling

The cutter radius is also constrained by the minimum radius of a free form profile, as shown in Figure 5.9. As complex tool path generation is beyond the scope of the current implementation of the OPTIMUM system, this minimum radius is defined by the user as part of the operation geometry.

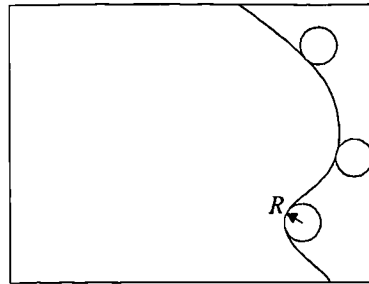

Figure 5.9: Cutter radius constraint for a free form profile

Considering the axial characteristics of the milling tool, several other geometric constraints are active (see Figure 5.10). The gauge length of the cutter must be larger than the total axial depth of the operation (H), or the cutter will be unable to cut down to the bottom surface of the operation geometry.

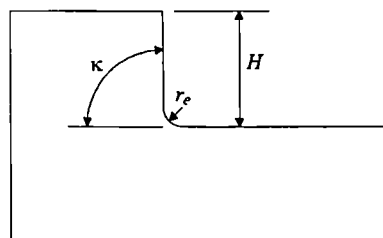

Figure 5.10: Axial cutter dimension constraints

The inner corner radius of the operation, if defined, will constrain the maximum feasible tool nose radius (r_e). The approach angle of the cutter (κ) should be compatible with the

inclination of the vertical side faces of the operation. For instance, square shoulder operations require the use of cutters with parallel sides i.e. $\kappa = 90^\circ$.

Some milling operations feature other specific geometric limitations. For example, T-slotting cutters are constrained by width, depth, neck width and neck depth.

(d) Test approach path for collisions

Check that the cutter can get within the planned operation without colliding on its approach. This is difficult to implement as there is no comprehensive workpiece geometry representation within the program, so it has been temporarily omitted.

(e) Test holder rake angles suitability for material type

The user can specify a number of rules that define critical rake angles for different classes of material. For example, face milling aluminium requires a positive geometry of cutter with an axial rake of about $+15^\circ$ and a radial rake of about $+15^\circ$. The user defined rules are held in a separate database and the checking may be activated (or deactivated) by the user. Appendix I contains definition of each rake angle and a short discussion on common configurations of rake angles. A set of sample rules derived from Sandvik (1985) is shown in Table 5.1.

(f) Test insert grade suitability for the workpiece material

The ISO carbide application designation of the workpiece material is compared with the range for which the insert is suitable. A separate insert grades data table relates all the available insert grades with the appropriate ISO carbide application ranges that each insert grade is capable of machining, as shown in Appendix F.

(g) Test holder size suitability for machine tool

It is important to check that the holder is not too big for the machine tool. This particularly relates to the vertical height of the tool holder and the spindle-to-bed dimension of the machine tool.

(h) Test cross-sectional area limits

The cross-sectional area of the operation is compared to the cross-sectional area of the cutter and the ratio compared with predefined limits. This prevents the use of unfeasibly

large or small cutters. The cross-sectional area ratio limits are currently set at 5% and 5000% for all operations. Further experimental work would be useful to assess if individual limits are required for different operation types.

5.5.2 Evaluation of the initial cutting parameters

Having checked that a tool is geometrically suitable for the given operation, it is necessary to generate an initial set of cutting data that is aggressive and may be optimized by reducing the severity of the cutting process later.

(a) Calculate the number of axial and radial passes

The number of passes for a straight sided operation such as slots, rectangular faces, square shoulders, chamfers and T-slots can be calculated from the cutter diameter and the maximum possible axial depth of cut for the cutter.

Considering how many transverse cuts are needed (all at the same depth) it is best to allow a lateral overlap between passes of at least 75% of the cutter diameter. Thus the number of lateral passes required is given by:

$$p_r = \text{int} \left(\frac{100W}{Da_{rmax}} + 1 \right) \quad (5.25)$$

where $\text{int}(\text{Expression})$ is the truncated integer part of Expression , p_r is the number of radial passes, W is the total radial width of the operation (mm), D is the effective cutter diameter (mm), and a_{rmax} is the maximum allowable radial width of cut (mm)

Similarly the number of axial passes is given by:

$$p_a = \text{int} \left(\frac{H}{a_{amax}} + 1 \right) \quad (5.26)$$

where p_a is the number of axial passes, H is the total axial depth of the operation (mm) and a_{amax} is the maximum allowable axial depth of cut (mm).

It is worth noting that a_{amax} can be considerably greater than the edge length of an insert as a milling cutter can have several inserts mounted up its side to give a much longer effective cutting depth.

(b) Calculate the initial axial and radial depths of cut

If all the passes are assumed to be of the same width and axial depth then the radial width of cut (B) is given by:

$$B = \frac{W}{p_r} \quad (5.27)$$

The axial depth of cut (a_a) is given by:

$$a_a = \frac{H}{p_a} \quad (5.28)$$

(c) Test the radial width usage suitability for the operation

The permitted radial width usage of the cutter is compared to the radial depth of cut.

(d) Calculate the initial average chip thickness

Each milling cutter has a range of applicable chip thickness in which there is satisfactory chip forming. The initial chip thickness is calculated as a value in the range based on the cutting data harshness percentage specified by the user:

$$h_{zm} = h_{min} + \frac{(h_{max} - h_{min})harshness\%}{100} \quad (5.29)$$

where h_{zm} is the average chip thickness (mm), h_{max} is the maximum average chip thickness for the cutter (mm), h_{min} is the minimum average chip thickness for the cutter (mm).

In addition to maximum and minimum values of h_{zm} , each cutter also has an associated step value of h_{zm} , called h_{step} , which is used to progressively reduce the average chip thickness during the optimization routine. Example values of h_{zm} ranges for a number of typical cutters are shown in Table 5.4.

Part number	Description	h_{min}	h_{step}	h_{max}
R215.49-1609.3-06	45 deg. chamfer cutter, D=9	0.05	0.01	0.08
R216.19-2525.0-09/220	End mill/drill, D=25	0.06	0.01	0.12
R220.13-0100-12	45 deg. face mill, D=100	0.07	0.03	0.22
R220.17-0125	Sq. shoulder face mill, D=125	0.06	0.02	0.18
R220.29-0040-06	Button insert face mill, D=40	0.06	0.015	0.12
R335.18-250.1418.60R	RH side & face mill, D=250	0.06	0.02	0.14
R417.19-2018.3-06	Spot facing end mill, D=18	0.06	0.01	0.08
R215.59-03020.020-06	MT3 helical mill, D=20	0.04	0.02	0.10
R217.69-3240.3S-13A	Sq. shoulder mill, D=40	0.06	0.02	0.18
R395.19-3240.4-18	T-slot mill, D=40, a=18	0.06	0.01	0.10

Table 5.4: Average chip thickness ranges for typical cutters

For finishing operations the initial feed per tooth is given by equation 5.19:

$$s_z = \left(18R_a r_e \sqrt{3}\right)^{\frac{1}{2}}$$

This is the maximum feed per tooth allowed to achieve the given surface finish. This must lie within the s_z limits for the insert. If it is too high then it is limited to the maximum for the insert. If it is too low then the surface finish cannot be achieved and the cutter/insert combination is disregarded.

(e) Calculate the constants in the extended Taylor's equation

The α , β and C_1 constants are calculated from a modified version of Taylor's equation for tool life, given as equation 5.8. Example values for tool life and cutting velocity are taken from recommended cutting data. With at least 3 sets of data it is possible to calculate the best fit values of α and β using multiple regression.

(f) Calculate the expected tool life

The cost per set of cutting edges, y , is calculated in the following way:

$$y = \frac{4n_i c_i}{3n_{ce}} + \frac{c_a c_h}{100} \quad (5.30)$$

where y is the cost per set of cutting edges (£), n_i is the number of inserts on the given cutter, c_i is the cost of one insert (£), n_{ce} is the number of cutting edges per insert, c_a is the percentage of the cost of cutter that is absorbed by each operation and c_h is the cost of the cutter (£).

The expected tool life for minimum cost is given by equation 5.21:

$$T_{exp} = (\alpha - 1) \left(\frac{n_i x t_3 + y}{x} \right)$$

For maximum production rate, the expected tool life is given by equation 5.22:

$$T_{exp} = (\alpha - 1) n_i t_3$$

These two tool life equations are both derived for turning so the expected tool life must be adjusted later to account for the discontinuous cutting experienced in milling (see step j). For fixed tool life, the expected tool life is defined by the user.

(g) Calculate the initial plunging parameters

For pocketing operations not accessible from the side, it is necessary for the cutter to plunge vertically (in the Z direction) into the workpiece. Although the passes in the XY plane will probably form the major part of the metal removal operation, it is necessary to generate a simple and reliable set of parameters for the initial plunging operation.

The plunging cutting parameters are generated using a version of the main cutting data optimization procedure, modified for a vertical rate of feed. Cutters are checked for the

ability to plunge to the required depth. The only process constraint that is implemented is power, so initial plunging parameters will be reduced in a stepwise fashion if the machine tool cannot deliver the required power for the plunging operation.

(h) Calculate the initial feed per tooth

Feed per tooth is related to average chip thickness in the following way:

$$s_z = \frac{h_{zm} \phi_s D}{2B \sin(\kappa)} \quad (5.31)$$

where κ is the approach angle of the cutter ($^\circ$).

The engagement angle, ϕ_s , is given by

$$\phi_s = \cos^{-1}\left(\frac{2e - B}{D}\right) - \cos^{-1}\left(\frac{2e + B}{D}\right) \quad (5.32)$$

A derivation of equation 5.32 is given in Appendix H.

(i) Calculate the equivalent feed rate

The equivalent feed rate is given by equation 5.3:

$$s_{eq} = \frac{s_z}{\phi_s} \left(\frac{\phi_s}{2} - \frac{\sin(2\phi_s)}{4} \right)$$

(j) Calculate the initial cutting velocity

The extended Taylor equation may be expressed as:

$$T_{exp} \left(\frac{\phi_s}{\pi} \right) = \frac{C_1}{v^\alpha s_{eq}^\beta} \quad (5.33)$$

The expected tool life is multiplied by $\frac{\phi_s}{\pi}$ because T_{exp} is calculated assuming that the cutter is fully engaged i.e. $\phi_s=\pi$, so the expected tool life can be scaled down when ϕ_s is known.

From equation 5.33, the initial cutting velocity can be expressed as:

$$v = \left(\frac{C_1 \pi}{T_{exp} \phi_s s_{eq}^\beta} \right)^{\frac{1}{\alpha}} \quad (5.34)$$

(k) Calculate the angular velocity of the cutter

The initial angular velocity of the cutter is given by:

$$n = \frac{1000v}{\pi D} \quad (5.35)$$

where n is the angular velocity of the cutter (r.p.m).

(l) Test the cutter r.p.m. against the machine tool limits

The cutter r.p.m. is tested against the minimum and maximum r.p.m. achievable by the specified machine tool.

(m) Calculate the specific resistance to cut

Typical values of specific resistance to cut are included in the main sample cutting data database which is used to calculate the coefficients for Taylor's equation. Alternatively, Seco Tools AB (1994) present a method for calculating k_{sm} from the Seco material group using the following expression:

$$k_{sm} = k_{c1.1} \left(\frac{1 - 0.01\gamma_o}{h_D^{mc}} \right) \quad (5.36)$$

where γ_o is the orthogonal rake angle of the cutter ($^\circ$), h_D is the nominal chip thickness (mm), mc is an exponent related to material group and $k_{cl,1}$ is given in Table 5.5, also from Seco Tools AB (1994).

Seco material group	Mild and alloy steel	$k_{cl,1}$	mc
1	Very soft "tacky" steels.	1350	0.21
2	Free-cutting steels.	1500	0.22
3	Structural steels, ordinary carbon steels.	1500	0.25
4	High carbon steels, ordinary low-alloy steels.	1700	0.24
5	Normal tool steels.	1900	0.24
6	Difficult tools steels.	2000	0.24
7	Difficult high-strength steels.	2900	0.22
Stainless steel			
8	Easy-cutting stainless steels.	1750	0.22
9	Moderately difficult stainless steels.	1950	0.20
10	Stainless steels difficult to machine.	2150	0.20
Cast iron			
12	Cast iron with medium hardness.	1150	0.22
13	Low-alloy cast iron with low hardness.	1225	0.25
14	Medium-hard alloy cast iron.	1350	0.28
15	High-alloy cast iron difficult to machine.	1470	0.3
Other materials			
16	Free cutting non-ferrous materials.	700	0.25
17	Non-ferrous materials	700	0.27
20	Nickel cobalt and iron based superalloys < 30Rc	2600	0.24
21	Nickel cobalt and iron based superalloys > 30Rc	3300	0.24
22	Titanium based alloys	1450	0.23

Table 5.5: Parameters for the calculation of specific resistance to cut

(n) Calculate the number of tooth engagements

The number of cutting teeth engaged at any one moment is given by:

$$N_{eng} = \text{int} \left(\frac{\phi_s N_i}{2\pi} + 1 \right) \quad (5.37)$$

where N_{eng} is the maximum number of instantaneous tooth engagements.

(o) Calculate the total resultant cutting force

The total resultant force acting on the cutter is given by:

$$F_{total} = \frac{k_{sm} N_{eng} a_a h_{zm}}{\sin(\kappa)} \quad (5.38)$$

where F_{total} is the total resultant cutting force (N).

(p) Calculate the metal removal rate and table feed rate

The table feed rate (s_{table}) is given by:

$$s_{table} = s_z n_i n \quad (5.39)$$

and the metal removal rate (m) is given by:

$$m = s_{table} a_a B \quad (5.40)$$

(q) Test the table feed rate against the machine tool specification

The required table feed rate is compared with the limiting values stored in the machine tool data table.

(r) Calculate the required cutting power

The required cutting power is given by:

$$P_{cut} = \frac{k_{sm} m}{60} \quad (5.41)$$

(s) Calculate the available machine tool spindle power

Spindle power is given by:

$$P_{spin} = \frac{P_{eff} \times \eta}{100} \quad (5.42)$$

where P_{spin} is the spindle power (W), P_{eff} is the effective available power and η is the power transmission efficiency of the machine tool.

(t) Test the required cutting power against the available spindle power

The required cutting power, calculated at step (r), is compared with the available spindle power, calculated at step (s).

(u) Calculate the overall cutting distance and cutting time

The cutting distance is calculated from the sum of the lengths of all the machining passes, as follows:

$$L_{total} = p_a p_r L \quad (5.43)$$

where L_{total} is the total length of cut (mm) and L is the length of cut of one pass (mm).

The cutting time is calculated by dividing the cutting distance with the table feed rate.

$$t_2 = \frac{L_{total}}{S_{table}} \quad (5.44)$$

where t_2 is the total cutting time (min).

(v) Calculate the total cost of the operation

The total cost of machining a component comprises several different parts:

1. Non-productive cost (K_1)

$$K_1 = x t_1 \quad (5.45)$$

where x is the cost rate of the machine tool (£/min) and t_1 is the non-productive time (min).

This cost is incurred due to non-productive time which includes loading and unloading time, setup time and other idle times such as breakdown and maintenance time.

2. Machining cost (K_2)

$$K_2 = x t_2 \quad (5.46)$$

The machining cost consists of the cost of the time used for the actual machining process. This machining time is often assumed to be the same as the actual cutting time although it can also include rapid traverse time and cutter approach time (these are often small when compared to the actual cutting time).

3. Cutting edges change cost (K_3)

$$K_3 = xt_3n_i \frac{t_2}{T} \quad (5.47)$$

where t_3 is the time required to replace a set of worn edges (min).

A part of the cost of this change time is consumed for each component, the proportion being equivalent to the fraction of the expected tool life that has been consumed by the cutting process.

4. Tool cost (K_4)

$$K_4 = y \frac{t_2}{T} \quad (5.48)$$

The cost of a set of cutting edges, y , is amortized over a number of components by multiplying by the percentage tool wear for each component.

The total operation cost (c_{total}) is the sum of each of the above four costs:

$$\begin{aligned} c_{total} &= K_1 + K_2 + K_3 + K_4 \\ &= xt_1 + xt_2 + \left(xt_3n_i \frac{t_2}{T_{exp}} \right) + \left(y \frac{t_2}{T_{exp}} \right) \end{aligned} \quad (5.49)$$

(w) Store the machining parameters

The axial and radial depths of cut, cutting velocity, expected tool life and table feed rate are stored in preparation for the metal removal rate optimisation procedure.

5.5.3 Optimization of the cutting parameters

The optimization procedure described in this section is based upon the approach of initially generating data that is as aggressive as possible and then gradually reducing the severity of this data until all the active constraints have been satisfied.

In order for initial cutting data to be generated for a given cutter/insert combination, many geometric and material constraints must be satisfied. The most common process constraint that can be exceeded is the power requirement. If any process constraint was not satisfied in the previous sections it is necessary to reduce the severity of the cutting process. The three major parameters that can be changed to effect this reduction are average chip thickness, h_{zm} , radial width of cut, B and axial depth of cut, a_a .

It is most economical to reduce these parameters in ascending order of impact on tool life and cost i.e.

1. Decrease chip thickness
2. Decrease radial depth of cut
3. Decrease axial depth of cut

The optimization cycle is shown in Figure 5.11. The following sections describe the reduction applied to each of the three operation parameters in the optimization routine.

(a) Reduce the average chip thickness

The first optimization procedure to be attempted is achieved by reducing h_{zm} by a small step value, h_{step} . This step value is stored for each cutter as part of the h_{zm} application range of the cutter. If the new value of h_{zm} is still valid for the cutter/insert combination, then the cutting conditions are recalculated. Otherwise, h_{zm} is restored to its initial value before the optimization routine and the program moves on to the next step.

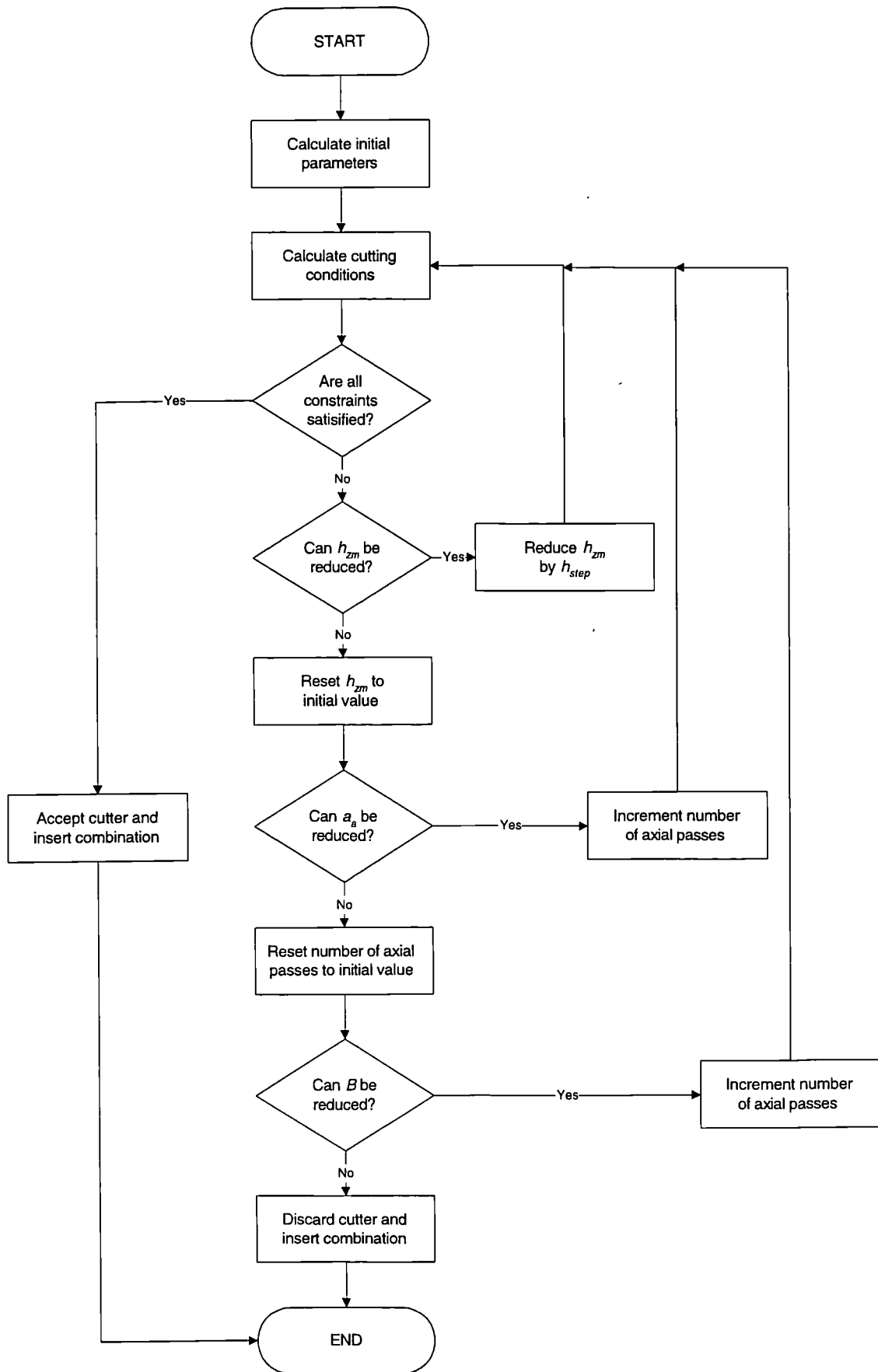

Figure 5.11: Cutting data optimization routine

(b) Reduce the radial depth of cut

The radial depth of cut is reduced by increasing the number of radial passes by one and recalculating the radial depth of cut. If the new radial depth of cut gives a radial usage greater than the minimum user-specified value then the cutting conditions are recalculated. Otherwise, the number radial passes is restored to its initial value and the program proceeds to the final optimization step.

(c) Reduce the axial depth of cut

The axial depth of cut is reduced by increasing the number of axial passes by one and recalculating the radial depth of cut. If the new axial depth of cut is greater than the user-specified minimum, a_{amin} , then the cutting conditions are recalculated. Otherwise, the cutter/insert combination is rejected because it is impossible to reduce the essential cutting parameters any further.

(d) Accept the current cutter and insert

If a cutter/insert combination reaches this point and it was not rejected at the previous step then the current values of the cutting parameters must fulfil all the process constraints. The cutting parameters and cutter/insert information is stored in the suggested tool list table.

A graphical representation of the path of the search routine within the h_{zm} - B - a_a parameter space is shown in Figure 5.12.

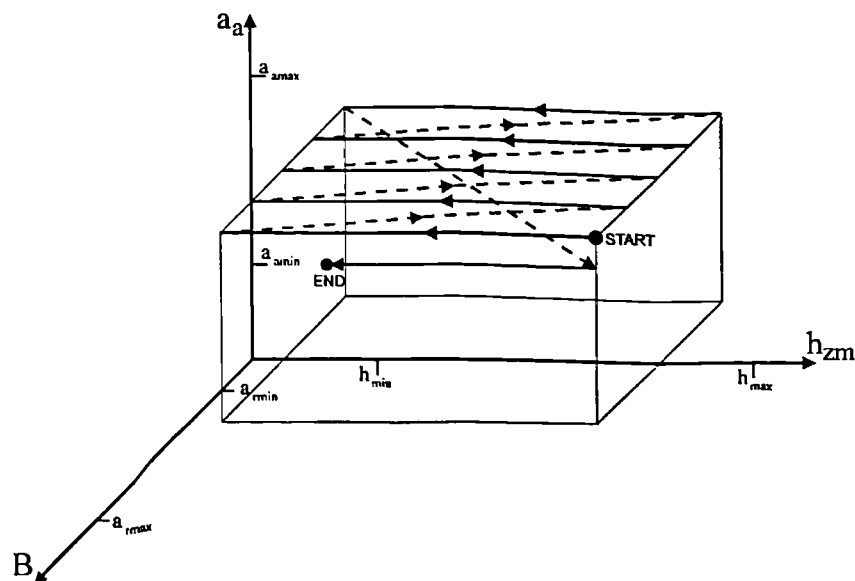

Figure 5.12: Optimum point search route within operation parameter space

As shown in Figure 5.12, the optimization routine progresses over a rectangular volume in h_{zm} - B - a_a space, tending to reduce each of the three variables in sequence. This rectangular volume is not necessarily the feasible parameters volume as other constraints will tend to intersect with it and reduce the overall volume within which feasible solutions can exist. The power constraint forms a curved surface within this parameter space and the final solution point, if there is one, will tend to lie near this surface. A possible future enhancement of this optimization routine would be to consider points near this power constraint surface first to reduce the overall processing time, in a similar way to the cutting data optimization method of Arsecularatne *et al.* (1992).

5.5.4 Handling of sub-operations

If the main operation was decomposed into several sub-operations then it is necessary to repeat all the previous calculations for the subsequent sub-operations.

The tool selection procedure for several sub-operations is subtly different for different types of operation:

SLOTTING - The two sub-operations are the first pass and the remaining passes. The same tool is used for both to minimize tool changing time.

T-SLOTTING - The two sub-operations are a straight slot followed by a T-slot cut along this initial slot. These operations require different tools but they are related by the fact that the initial slot must be wide enough to accommodate the neck width of the t-slotting cutter. However this should not be problematic as most t-slotting cutters do not cut on the neck surfaces and therefore the initial straight slot must be wide enough to produce the final neck geometry.

5.5.5 User-defined tool sorting

Having generated a list of possible tools along with associated optimized cutting conditions it is necessary to apply some form of user defined sorting to the list in order to produce some best choice tools and to fulfil the function of tool selection as well as cutting data calculation.

There are four main criteria for the tool selection sort weighting:

1. Maximum metal removal rate
2. Maximum tool life
3. Minimum overall cost
4. Minimum overall time

As discussed in section 5.4.1, each weighting is applied to a normalized value of each appropriate parameter and summed to give an overall weighting. The overall weighting factor is given by equation 5.24:

$$w_{rank} = \left(\frac{m}{m} w_m \right) + \left(\frac{T}{T} w_T \right) - \left(\frac{C_{total}}{C_{total}} w_c \right) - \left(\frac{t_{total}}{t_{total}} w_{time} \right)$$

The example tools lists presented in Chapter 8 show how metal removal rate, tool life, cost and machining time are combined to give an overall weighting to sort the tools in order of preference.

5.6 Summary and discussion

The cutting data optimization and tool selection method described in this chapter facilitates the consistent selection of tools with aggressive cutting data for a range of milling operations. A wide range of machining knowledge are considered in order to derive a set of initial cutting conditions which satisfy a user specified objective functions of either maximum production rate, minimum production cost or a fixed tool life. The cutting data are further optimized to satisfy a set of technological constraints such as available power and required surface finish. Optimized cutting data is calculated for all the feasible tools that are available. The list of possible tools with associated cutting conditions is sorted by a user defined compound objective function that allows the tool list to be sorted in order of 'goodness' to produce a preferred choice of tool for the given milling operation.

This cutting data algorithm demonstrates an application of mathematical models, many derived for turning, to the problem of generating aggressive cutting data suitable for the process of automatic tool selection. The user is afforded a considerable degree of flexibility over the objective functions used to optimized the cutting data and select the best tool so as to best correspond to the prevalent requirements in any given manufacturing environment.

Considering the recent proliferation of new, high performance cutting geometries and insert materials, it is likely that many process planners and machine tool operators will not be using new tools to the fullest potential, preferring to stick to established methods and ranges of cutting data. The provision of computer aided tool selection methods can significantly improve the consistency of process plans and the utilisation of modern cutting tools.

Chapter 6

Tool variety reduction

The tool selection procedure described in Chapter 5 is highly effective for calculating optimized cutting data and selecting a tool for a single operation according to a variety of user-defined criteria. However, tool selection in an industrial environment should not be considered purely as a one stage operation. In reality there are two sets of constraints to be considered: the first are the process constraints that dictate the cutting conditions for any given tool, the second set of criteria are defined by the need to make best use of a tool within the work scheduling framework of a multi-job environment.

This chapter describes a post processor for the tool selection method of the OPTIMUM system that rationalizes the selected tools for a given set of operations on one or more components so as to reduce tool setup times and more effectively derive the optimum tool set for a given batch of components.

6.1 Introduction

Whilst it is perhaps most straightforward to select tools and optimized cutting data for each operation in isolation, it is possible to identify five levels of tool selection: Single operation, Component on a single machine, Multiple batch on a single machine, Multiple machines and finally Shop Floor [Maropoulos (1992)]. These tool selection levels and the associated interacting technologies are shown in Figure 6.1.

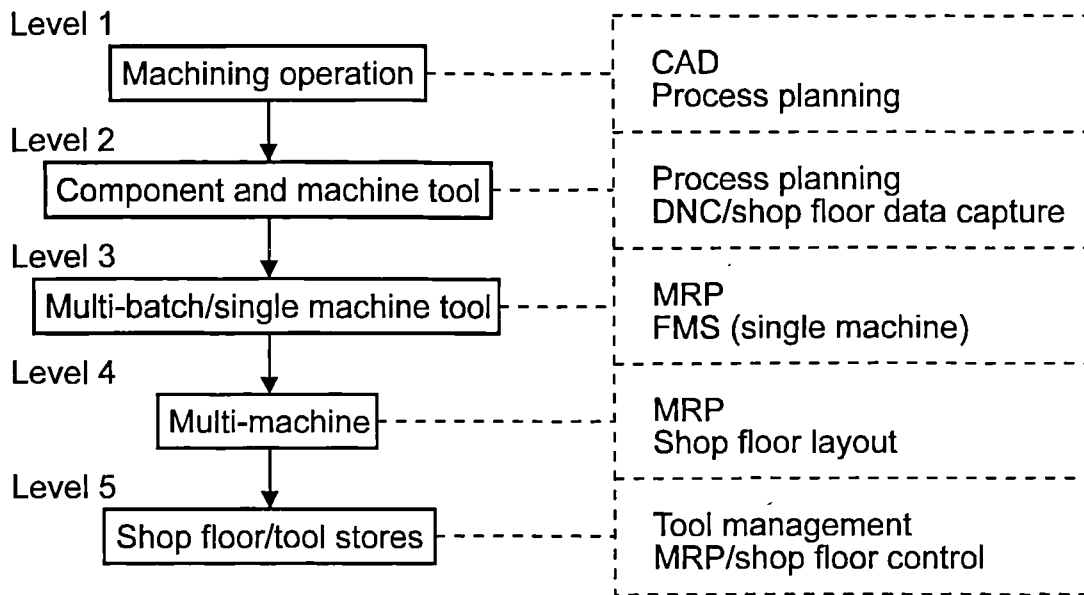

Figure 6.1: Tool selection levels and interacting technologies

It is noticeable that as the tool selection level increases, the work scheduling criteria become more important and the process constraints for each individual operation become less critical i.e. when selecting an optimized set of tools for a given set of operations it is likely that some operations will be carried out by a tool that is suboptimal if that operation is considered in isolation. The tool selection method of OPTIMUM selects tools at level one. The tool rationalization method described in this chapter provides tool selection at levels two and three.

Unlike level one, the selection of tools at levels two to five requires additional rationalization to reduce the variety of tools and to satisfy the additional work scheduling criteria encountered when considering tool selection for more than one operation at a time. The main rationalization criteria are:

1. Limited number of tool positions on the machine tool

Most modern machining centres provide a level of automated tool handling that allows a limited number of preset tools to be kept on the machine and automatically changed for different operations. These tools are often held in some form of carousel or magazine. Possibly the greatest advantages of automated tool handling is reduction in machine stoppage time as the tools can be preset before insertion into the tool carousel and then changed very rapidly by the machine. Thus it is highly desirable that

all the tools that are required for a given component should be accommodated in one tool set stored in the tool carousel. Often the number of unique tools selected for a component at tool selection level one will be higher than the number of available tool positions and some reduction of the variety of tools will be required by replacing locally optimal tools with suboptimal tools that can perform more than one of the required operations.

2. Reduction of tool inventory

The highly detailed tool selection procedure available at level one will tend to produce a high number of different tools, particularly if the database of available tools is large, as is the case with the OPTIMUM system. Whilst for just one operation it is best to select the most optimal tool possible, this can lead to a great variety of different tools that must be held in tool stores thus generating high costs for tool management, procurement and distribution. As with so many situations in process planning, there are several selection criteria that subtly conflict; select the best tool for the job but also keep down the level of tool variety. The associated additional costs of maintaining a large tool inventory are considerable. On the other hand, if the level of tooling variety is reduced too far then the generated process plans will not take advantage of the benefits of the ever increasing range of tool materials and geometries available for high performance metal cutting. However, selecting a subtly different tool for every milling operation is clearly not desirable.

3. Balancing of tool wear

As well as accommodating all the required tools for a given component in one tool set within the tool carousel, it is also important to manage the tool life usage of the individual tools to reduce the number of machine stoppages due to tool wear. Frequent stoppages to replace worn cutting edges are a major source of unproductive time within the machining cycle. Tool wear balancing is particularly important when using one tool to perform more than one operation, thus consuming more of the expected tool life than would be calculated for individual tools at level one. Also most components produced on a machining centre will be produced in batches and it is important to manage the tool life of the tool set so as to either eliminate tool life failure or to synchronise tool changes, thus reducing the number of stoppages required to change or index worn tools.

4. Use of sister tools

Some milling cutters are more versatile than others. For instance, some helical endmills may be used for facing, square shouldering, slotting, pocketing and contour milling. This can lead to some tools in an optimized tool set being used much more than other more specialized tools and this is likely to lead to early failure for these much used tools. This can be partly overcome by the use of sister tools. These are identical tools that are stored in spare tool positions and switched over when the current tool becomes critically worn. Of course, this may not be possible if the tool carousel has insufficient tool positions although for small batches it may be possible to reduce the tool wear rate sufficiently to eliminate the need for sister tools.

Several systems have been developed for automatic tool selection and cutting data determination although there has been less published literature about the process of rationalizing tool selection for components or batches of components. Sheikh *et al.* (1980) report a method of optimizing cutting conditions with regard to tool replacement strategies. A probabilistic model of tool life is used to produce preventive planned, scheduled and failure replacement strategies. Research at UMIST has produced modules for the TECHTURN process planning system that perform tool variety reduction and wear balancing for turning tools [Maropoulos & Hinduja (1989), Zhang & Hinduja (1995)]. Arsecularatne and Mathew (1995) describe a tool replacement procedure that determines the optimum number of components to machine between tool changes in order to minimize the total cost due to tools and tool changing.

In order to rationalize a set of individually selected tools to produce an optimized tool set for tool selection levels two and three, several processes are generally required. These include tool regulation, tool substitution and tool wear balancing. The following sections 6.2 to 6.4 present a discussion of each of these tasks. Finally, section 6.5 describes the tool variety reduction method implemented in the OPTIMUM system.

6.2 Tool regulation

Tool regulation may be considered as the main process required when the number of available tool positions on the machine tool exceeds the number of unique tools required

for the batch of components. Some heavily used tools may be duplicated in the empty tool positions so as to increase the available wear life for that type of tool. Maropoulos and Hinduja (1989) suggest that it is best to duplicate those tools that are most likely to fail i.e. the tool with the highest wear percentage per component, where the wear percentage is given by:

$$\text{wear} = \frac{100t_2}{T_{\text{exp}}} \quad (6.1)$$

This wear percentage can be used to calculate the number of components (not necessarily a whole number) that can be machined within the useful life of a given tool as follows:

$$\text{mnc} = \frac{100}{\text{wear}} \quad (6.2)$$

If an economic batch size is known then it is straightforward to add duplicates of the tools that are most worn. The remaining single (unduplicated) tool that has the highest wear percentage will generally define the number of parts between tool changes.

The regulation of tool sets by adding sister tools is a simple and straightforward technique to reduce the problems of uneven wear loading often found when using preset tool carousels. However, this approach has several basic requirements that must be fulfilled. Firstly, the tool stores must possess sufficient tools to be able to provide duplicates of the most highly worn tools. This will be dependent upon the tool management strategy adopted by any given company and it is not to be taken for granted (although inserts are fairly inexpensive, many modern cutters are relatively costly). Secondly, the tool handling system of the machine tool must have some empty tool positions to allow the placement of duplicate tools. It is likely that, for components of typical complexity, the number of unique tools required could exceed the number of tool positions available on some small machining centres. Finally, the use of sister tools

requires that the part program must be changed so that the correct tool numbers are used to employ the sister tools on certain operations.

6.3 Tool substitution

If the number of available tool positions is less than the number of unique tools selected for a component then some tool substitution method is required to reduce the number of unique tools needed. Fortunately, many modern milling cutters are versatile and can be used for several different types of operations. Some tools within the initial tool set may be suitable to perform one or more of the other operations, thus reducing the number of unique tools. This process of substitution requires a consistent method of evaluating similarity between tools. The two levels of similarity that must be achieved to allow substitution are capability and performance. The substituted tool must be able to machine the same area as the tool to be replaced - this is largely due to the geometric characteristics of the milling cutter. Also, the substitute tool must offer compatible machining performance, which for identical cutters is largely defined by the shape and grade of the inserts. Tool substitution can be achieved by using one of several different similarity criteria: identical tools, identical holder and similar insert, compatible holder.

6.3.1 Identical tools

This is the simplest form of similarity checking and it is achieved if the two tools under consideration are identical (i.e. the same holder and the same insert type and grade). Clearly if the same tool is selected for two or more operations, the substitution is straightforward as the capability and performance of the two tools are identical. The suggested cutting data will be feasible for each of the operations without any modification. The only reason for modifying the suggested cutting data would be to reduce the tool wear to allow the single tool to cut more than one operation without requiring additional tool stoppages to index the cutting edges.

If just a list of individual selected tools is available then any identical tools will be immediately identifiable. This type of check is also suitable when attempting to rationalise tool selection across a set of operations where the list of possible tools and cutting data used during the initial selection procedure is still available. In this case, an tool may be replaced by a suboptimal tool that is identical to a tool used for another

operation. Considering software implementation issues, identical tool checking is the simplest and most rapid form of tool variety reduction.

6.3.2 Identical holder and similar insert

If no identical tools can be found then the level of compatibility for substitution can be relaxed. The number of exact matching criteria is reduced to one - the substitute tool must have the same cutter. Different inserts are allowed since most modern indexable inserts are sufficiently versatile to be able to perform a wide range of operations, even on unlikely materials. The use of a different, suboptimal insert is likely to reduce the cutting performance and increase the machining time and cost of the particular operation.

6.3.3 Compatible holder

If no suitable substitute tool can be found for the first two levels of similarity then a process of similarity checking can be used. The only criterion is that the substitute tool should be able to perform the given operation. Many operations can be achieved with a different type of holder. For instance, a facing operation will generally have a facing tool selected although this could be replaced with a square shoulder cutter, helical cutter, endmill and even some copy milling cutters. Maropoulos and Hinduja (1989) suggest that a suitable level of similarity can be assessed for turning tools by comparing the first five characters of the ISO code of the holder. These characters define the clamping method, insert shape, holder style, clearance angle and hand side, respectively. Unfortunately, the geometry related machining characteristics of milling cutters are considerably more complex than those for turning tools. The tool selection method described in Chapter 5 requires that each milling cutter has an associated series of codes that exactly define the milling operations which are achievable. These codes can be used to initially assess if an available tool is generally capable of performing the given operation. Further specific calculations are required to check if a cutter has suitable geometry for the given operation e.g. a slotting cutter must have a smaller diameter than the slot diameter.

6.4 Wear balancing

When calculating optimized cutting conditions for tool selection purposes, the objective functions are often stated as expressions of tool life, as discussed in Chapter 5. This

provides a convenient method for relating the various process parameters to the desirable objective state. However, these tool life objective functions do not generally consider the overall machining time or batch size. Thus it is likely that the generated cutting data will be optimal for the selected objective function but the associated tool life will result in the machining of a non-integer number of components which may be less than the batch size. With a set of tools this misalignment of tool life consumption becomes more problematic as the tool change times for different tools can occur in a scattered pattern across all the intervals between components. Tool changing time can be significantly reduced if the cutting data is modified so that the wear pattern of several tools allows synchronised tool changes to take place, as shown in Figure 6.2.

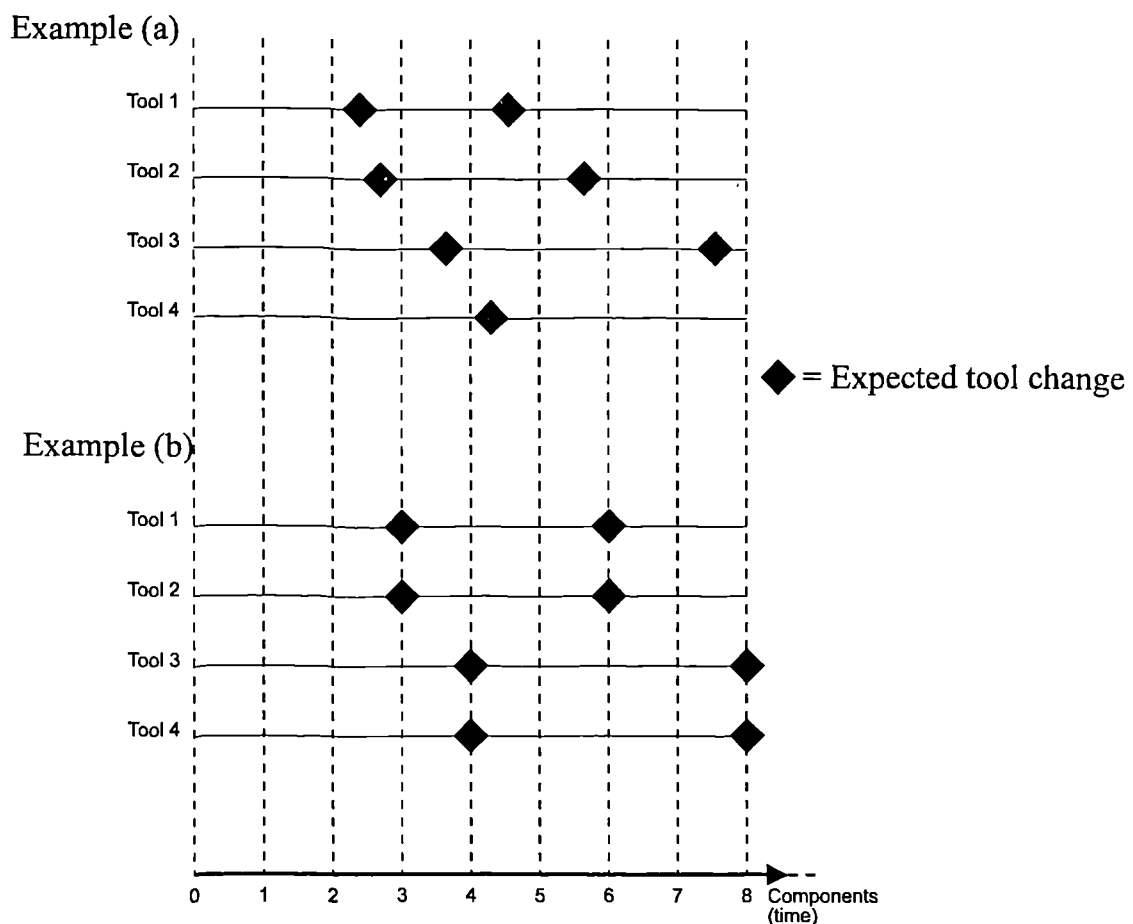

Figure 6.2: Reduction of tool change time by wear balancing

Example (a) shows a typical range of initial tool lives for a set of tools. The optimization procedure described in the previous chapter does not consider the undesirability of changing a tool during a cut. Thus, the expected tool lives tend to expire in the middle of

a component and at irregular intervals when compared with the other tools used on the component. Catastrophic tool failure may occur as a result of completing a cut with a worn out tool. By iteratively adjusting the expected tool life, a new set of cutting data can be found that will allow synchronised tool changing, as shown in example (b) in Figure 6.2. Maropoulos and Hinduja (1989) present a detailed treatment of how this adjustment may be achieved for turning operations and also how to resolve the question of whether the tool life of an individual tool should be increased or reduced to machine an integral number of components.

As is often encountered when attempting to interface manufacturing process planning systems with scheduling functions, the number of possible combinations of adjusted tool wear patterns can grow exponentially. Whilst small changes in the cutting conditions can lead to cutting which is still highly efficient, if the number of tool changes is to be substantially reduced then the tool life modification required may be quite large i.e. more than just to the machining time for the next greater or lesser integral number of components. As can be seen in Figure 6.2, the number of tool changes required to produce eight components can be reduced from seven to four with only small changes in the expected tool life of each of the four tools. If the number of tool changes is to be reduced to two (all the tools will be changed simultaneously) then larger tool life adjustments are needed, of an order greater than the machining time of one component. Reduction of stoppages for tool changing will require the wear rate for certain tools to be increased or decreased. In the former case, process constraints may prohibit the generation of feasible cutting conditions to give the reduced tool life.

6.5 Variety reduction method

The tool rationalization module of the OPTIMUM system performs an exhaustive tool variety reduction function. Tool regulation and wear balancing is not currently implemented for reasons of a lack of development time. These extended functions are likely to be addressed in a future research project.

As described in section 6.3, the process of variety reduction by tool substitution requires several functions for assessing the compatibility of alternative tools and for modifying the suggested cutting data in order to use a suboptimal tool [Gerloch (1992)]. It is

noticeable that most of the checks and calculations performed in these functions are also implemented in the tool selection module described in the previous chapter. For instance, the tool selection process includes the assessment of suitability and calculation of cutting data for a wide range of available tools. A large number of feasible tools may be assessed but ultimately only one tool will be selected (generally the first one in the sorted tool list). The list of alternative tools with associated cutting data is usually then redundant and may be discarded.

However, the surplus data that is generated to form the initial tool list for tool selection can be used to reduce the complexity of the tool variety reduction process. The cost of computing power and storage media has decreased greatly over the last decade so the use of exhaustive searching and the storage of large tables of data has become much more common than in the early days of microcomputer technology. It is now quite viable to manage tool lists containing hundreds or even thousands of feasible tools. The tool selection procedure can be executed on the largest list of available tools and this will generate cutting data for a substantial list of suboptimal tools. In the OPTIMUM system, each tool is marked by a series of codes that define what milling operations can be performed by that particular tool. These codes can include unusual or uncommon applications. For instance, chamfering tools, endmills, square shoulder cutters and even some slotting tools can perform simple facing operations. Thus, an exhaustive tool selection procedure for a facing operation will produce a tool list with facing cutters at the top and these other types of cutter, if available, lower down in the list. Whilst for general tool selection purposes the data generated for these unconventional tools is probably not useful, this data can be used to reduce the tool substitution problem to the simplest task of just checking for identical tools. The process of modifying optimized cutting data when trying to apply a subtly different tool to an operation is eliminated as every feasible and available cutter/insert combination will already have been considered for each operation. The tool substitution problem is thus reduced to a pattern matching exercise.

6.5.1 Search strategy

For a set of n operations, the tool selection method of OPTIMUM produces n lists of tools and associated cutting data, each sorted according to user defined criteria. A representation of a set of three such lists is shown in Table 6.1. The tool lists may be of variable lengths, according to the number of feasible cutters and inserts that are available for each operation.

	Operation 1	Operation 2	Operation 3	...	Operation n
1st	Tool A	Tool G	Tool E
2nd	Tool B	Tool H	Tool A		...
3rd	Tool C	Tool A			...
4th	Tool D	Tool J			...
5th	Tool E				...
...					...
x th				...	Tool (x,n)

Table 6.1: Tool lists for a set of operations

An exhaustive search is performed across these lists to generate the complete set of possible combinations of n tools. This is best achieved by using a recursive algorithm to scan down each tool list, adding each tool to a prospective tool set and then recursively processing the next list. For example, the first three tool lists shown in Table 6.1 would yield the following set of possible combinations of three tools for operations 1, 2 and 3:

AGE, AGA, AHE, AHA, AAE, AAA, AJE, AJA, BGE, BGA, BHE, BHA, BAE, BAA, BJE, BJA, CGE, CGA, CHE, CHA, CAE, CAA, CJE, CJA, DGE, DGA, DHE, DHA, DAE, DAA, DJE, DJA, EGE, EGA, EHE, EHA, EAE, EAA, EJE, EJA.

For such short tool lists generating this number of possible tool sets is not problematic. However, it is possible to generate tool lists with several hundred feasible tools and the number of possible tool sets can grow explosively. This problem can be lessened by the addition of a check in the recursive routine that counts the number of unique tools in each combination as they are formed. If the number of unique tools is greater than the number of tool positions available then the recursive search is failed at that point (although it may well continue in other branches of the search tree). This method eliminates the generation of whole branches of tool combinations that all contain too

many unique tools. Thus, the search is still exhaustive but does not necessarily check every possible combination of tools.

If the tool lists given in Table 6.1 are rationalized for a machine with just two available tool positions, the possible tool sets will be AGA, AHA, AAA, AJA, EGE, EHE, EAE, EJE. The algorithm does not include a check to remove combinations that reduce the tool variety too far, such as the combination AAA in the above example. This is because each combination of tools is evaluated according to the original tool selection criteria and an over-optimized tool set will tend to incur a greater performance penalty than a combination featuring fewer tool substitutions.

6.5.2 Sorting of rationalized tool sets

As with the tool selection method described in the previous chapter, the tool variety reduction method calculates all the possible tool setups and then sorts them by user-defined criteria to produce a preferred solution. All the tools in the stored tool lists have associated optimized cutting data and a weighting factor that was used to sort the list into an order of preference. As these weighting factors reflect the preferred performance characteristics of individual tools, they can be used to evaluate the performance penalty of substituting tools to reduce tool variety. For each derived combination of tools, the associated weighting factors are summed and stored with the tool combination. The reduced tool sets are then sorted by this combined weighting factor to give the rationalized tool set that gives the least reduction in overall performance, as defined by the user. If each tool selection process is performed on all the available tools, this variety reduction approach is guaranteed to produce all the possible tool sets that satisfy the constraint of a limited number of available tool positions.

The tool lists shown in Table 6.1 are sorted according to a user specified objective function that is a function of metal removal rate, tool life, machining cost and machining time as presented in Chapter 5. As a simple example of this procedure, the tool lists shown in Table 6.1 are restated in Table 6.2 along with the associated weighting values generated in the tool selection procedure.

	Operation 1		Operation 2		Operation 3	
	Tool	Weight	Tool	Weight	Tool	Weight
1st	Tool A	2284	Tool G	2962	Tool E	1746
2nd	Tool B	1778	Tool H	2952	Tool A	686
3rd	Tool C	1768	Tool A	2402		
4th	Tool D	1170	Tool J	2098		
5th	Tool E	956				

Table 6.2: Tool list with tool selection weighting values

The rationalized tool sets to reduce the number of unique tools to two or less are the following combinations: AGA, AHA, AAA, AJA, EGE, EHE, EAE, EJE. For each of these tool sets, the weighting factors of the constituent tools are summed to give a combined weighting value for the tool set. Ordering the tool sets by combined weighting gives the list or rationalized tool sets shown in Table 6.3.

Tool set	Combined weighting
AGA	5932
AHA	5922
EGE	5664
EHE	5654
AAA	5372
EAE	5104
AJA	5068
EJE	4800

Table 6.3: Sorted list of rationalized tool sets

It can be seen that, for this example, the rationalized tool sets that gives the least decrease in machining performance comprises tools A, G and A again. It is interesting to note that the over-rationalized tool set of just tool A for all three operations appears some way down this list as the performance decrease entailed with two tool substitutions is often greater than that found with only one tool substitution.

6.5.3 User interface

The user is presented with a simple list based interface to facilitate selection of a set of operations for which optimized tool lists have already been calculated. The initial dialogue box is shown in Figure 6.3.

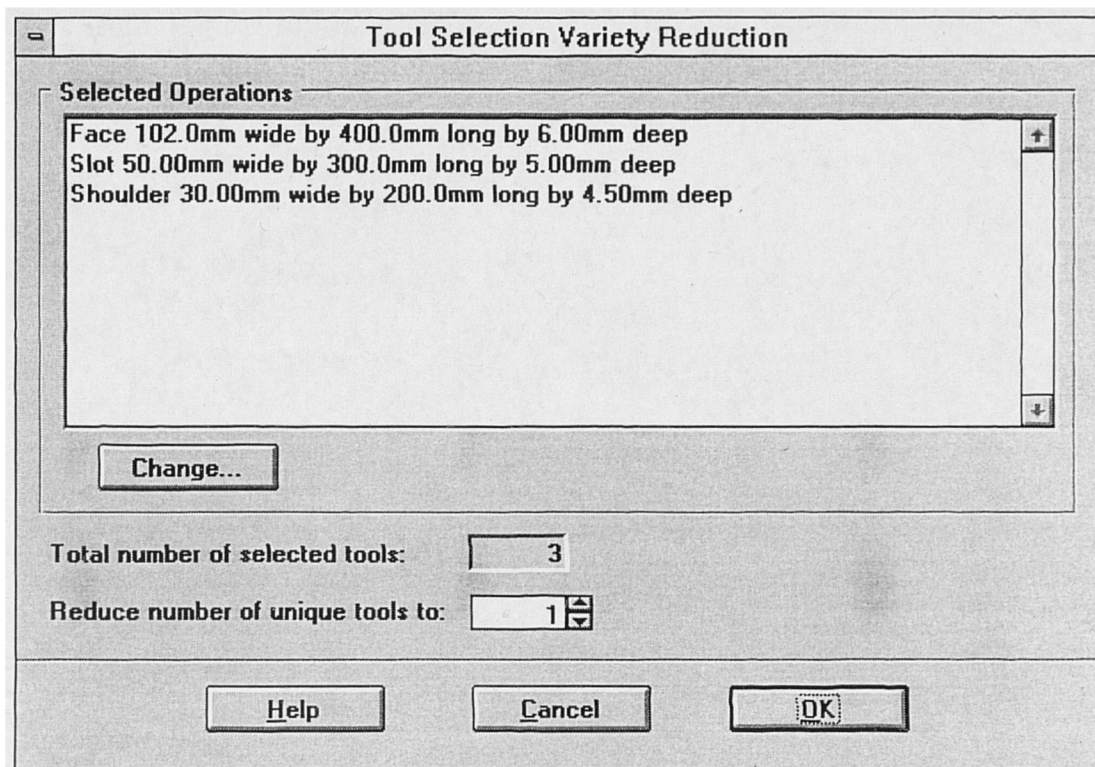

Figure 6.3: Setting the initial parameters for tool variety reduction

For a number of operations, n , the desired number of unique tools can be set to be any value between 1 and $(n-1)$. The exhaustive search is performed rapidly (a search of around 72,000 combinations takes a little less than one minute on a 33Mhz 486 PC) and the resulting sorted list of reduced tool sets is displayed as shown in Figure 6.4.

The dialogue box reproduced in Figure 6.4. shows that, for the operations defined in Figure 6.3, there are thirteen reduced tool sets containing just one unique tool. The tool that will produce the least degradation in objective function is the Seco cutter R220.17-0050 with the insert TPKN1603PDTL-MD12 in T25M grade. All the other reduced tool sets are available for viewing and the associated cutting data for any tool set is immediately available. A full example of a tool variety reduction procedure is given in Chapter 8.

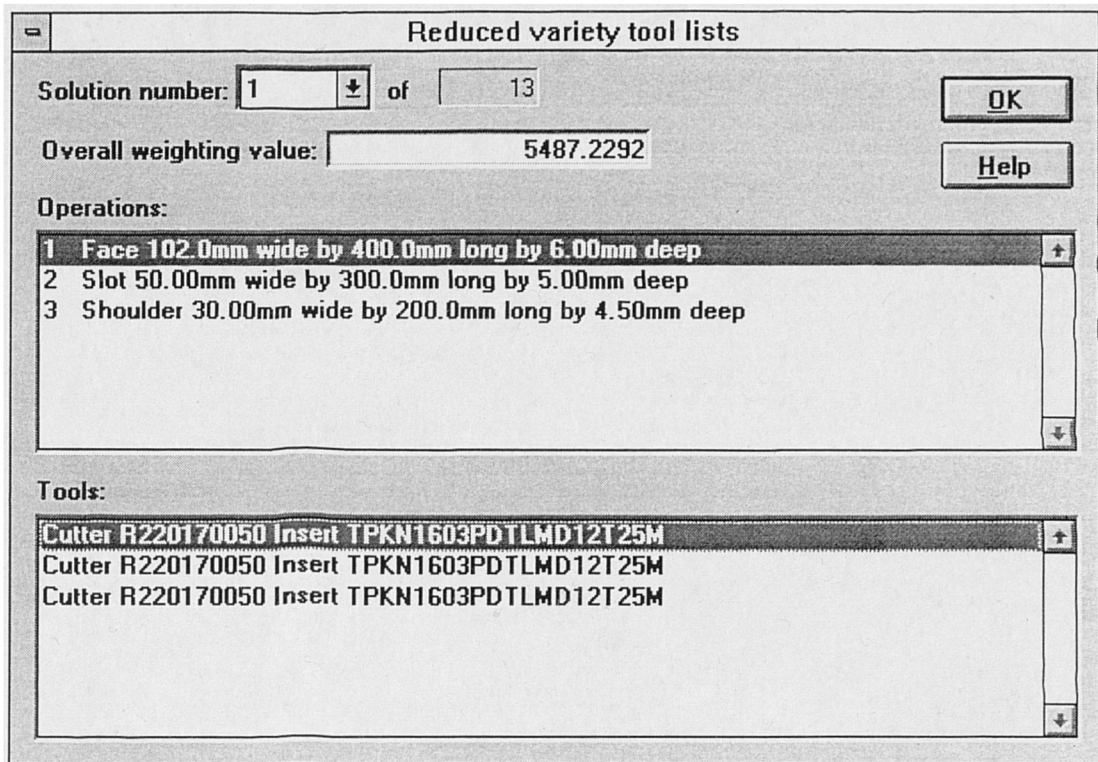

Figure 6.4: Results display of the tool variety reduction method

Chapter 7

Approved data collection and conformance assessment

The process planning system described in the previous four chapters is largely deterministic and 'open loop' i.e. the data is fed forward through the various algorithms and no data is fed back from the final destination of the cutting data, the shop floor. The models used in each of these algorithms can only ever be simplified simulations of reality and thus this feed forward structure is not ideally suited to producing reliable tool selection and cutting data determination for the dynamic machining environment. This chapter describes the formulation and implementation of a simple mechanism to feed data that has been approved on the shop floor back into the system so as to allow the cutting data generated by the system to better conform to the specific prevailing manufacturing conditions. The system thus becomes 'closed loop'.

This chapter describes the background to the problem of approved data conformance assessment. Two different methods for evaluating the relationship between suggested and approved data are discussed. The first method, multiple regression analysis, has been fully implemented in the OPTIMUM system as described in section 7.4.1. The second method, neural networks, offers considerable potential for refining the conformance assessment process in an industrial environment. The functional layout of the conformance assessment method in OPTIMUM is shown in Figure 7.1.

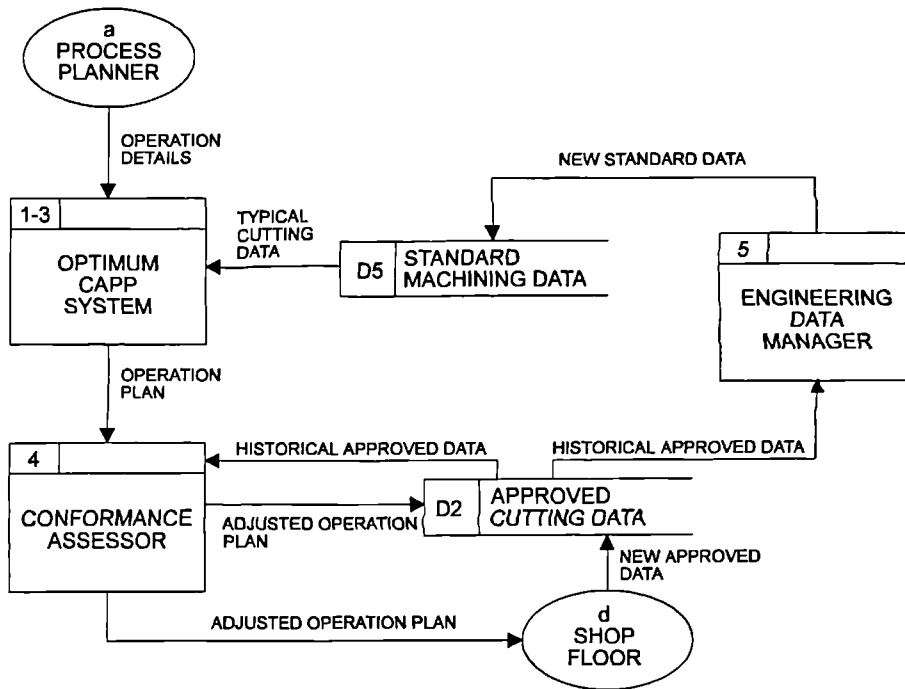

Figure 7.1: Functional layout of the approved data feedback system

7.1 Introduction

CAPP systems often feature mathematical models of the cutting process that can only approximate the actual cutting mechanisms. This form of modelling is limited by the quality of the small amount of sample data that is used to generate cutting data for a wide range of milling operations and tool types. Generally, a mathematical model allows the complex responses of the cutting process (such as tool life, power consumption and cutting force) to be represented by equations rather than large tables of discrete values. Not only do these models reduce the amount of data storage space required (potentially by many orders of magnitude) but characteristic equations can also be used to predict the cutting response for operations or tools for which no sample data is available. Most of these systems are 'open loop' since all data is fed forward through the algorithm.

For any mathematical cutting data model, some example data is usually required for the evaluation of certain empirical constants. A good example of this is the prediction of tool life using Taylor's equation or a derivative of it. Example cutting data with associated tool life values are needed to calculate the material/tool specific constants in the equation (C_1 , α , β and γ). If tool life measurement facilities are available then it may be possible,

over an extended period of time, to gather further sample data so that the Taylor's equation constants may be updated. This could account for certain time dependent processes that affect the achievable tool life on a given machine tool. These will mostly be processes of wear that degrade the repeatability and overall accuracy of the machine tool such as bearing wear, lead screw wear and slide wear. The tool selection module of OPTIMUM calculates the Taylor constants at run time from a table of sample cutting data and tool life values. A simple substitution or addition of fresh example data in this data table will immediately bring the cutting data output closer to the actual tool life values being achieved on the shop floor.

However, there is a large source of verified cutting data available that is generally not exploited in CAPP systems. Every successful machining operation performed in a machine shop will yield a set of proven cutting data that is finally used to produce the machined surfaces. If this final cutting data that has been 'approved' is different to the cutting data suggested in the process plan used, then it is likely that it may be lost through not being recorded. The differences between the cutting data in the process plan and the final approved data is a useful source of knowledge about how the machining model in the CAPP system differs from the real and changing machining responses found on the shop floor. This knowledge can also be used to produce suggested cutting data that is compatible with constraints that are not explicitly programmed in the mathematical machining model. For instance, the cutting data optimization module of OPTIMUM does not include comprehensive chatter constraints. If data suggested by the OPTIMUM system is repeatedly being reduced to alleviate chatter problems then the knowledge arising from the approved data can be used in the future to reduce the suggested data from the system, thus lessening the likelihood of chatter problems. Prototype CAPP systems featuring approved cutting data feedback for turning operations have been developed at the University of Durham [Maropoulos (1992), Maropoulos & Gill (1995), Keating *et al.* (1995)].

7.2 Feedback data requirements

In order to effectively collect and process approved data from the shop floor, it is important to define what information is required. The approved data is constrained by several criteria:

1. Availability

The data should be easily available to the process planner or operator. It should be in a convenient form with standard units, preferably directly measurable from the machine e.g. cutting velocity, feed rate.

2. Ease of capture

The collection of the data should be straightforward. Thus, it is preferable to avoid any complicated time dependent data or large amounts of data that must be logged. Sensor based systems can be used but they can introduce new problems concerning sensor reliability and signal interpretation.

3. Relevance

This is perhaps the most complex and yet most important criterion. Defining a suitable set of parameters or attributes that consistently represent the efficiency of the machining operation can greatly contribute to the effectiveness of a feedback system. Extra or redundant data can generally be handled as it will be a function of some of the other data. However, it is important not to omit any relevant data, particularly for machining responses that are not fully described in the machining model of the CAPP system.

The data that is commonly available from a machine tool falls into three main categories: continuous, discrete and subjective. Continuous data is numerical information such as cutting velocity, depth of cut or feed per tooth which can take any value in a range of possible values. Some older machines can only set spindle speeds and feed rates at one of a range of discrete settings. Other discrete parameters include the cutter and insert description, the material type and some logical machining parameters such as cutting fluid and workholding methods. Many physical manifestations of machining performance such as noise, vibration and chip type are best described in subjective terms [Maropoulos

& Alamin (1995)]. Whilst most of these factors can be quantified and measured in some way, this process is often beyond the means of most machining enterprises in terms of time and cost.

The best people to input approved data into the system will be the machine operators as they have immediate access to the actual cutting parameters used and they often possess considerable machining experience with which to consistently express any subjective data that is required.

Field	Description	Type
1	Reference number (for approved data table)	Numeric
2	Machine type (e.g. mill, lathe, drill)	Numeric
3	Machine number (from machines database)	Numeric
4	Date of operation	Date
5	Component number	Numeric
6	Operation number	Numeric
7	Operation type	Numeric
8	Operation description	Character
9	Material group	Numeric
10	Machinability group	Numeric
11	Material description	Character
12	Material hardness	Numeric
13	Suggested cutting velocity, v	Numeric
14	Suggested feed per tooth, s_z	Numeric
15	Suggested average chip thickness, h_m	Numeric
16	Suggested radial depth of cut, B	Numeric
17	Suggested axial depth of cut, a_a	Numeric
18	Suggested radial passes	Numeric
19	Suggested axial passes	Numeric
20	Suggested tool life	Numeric
21	Suggested holder code	Numeric
22	Suggested insert code	Numeric
23	Suggested insert grade	Character
24	Approved cutting velocity	Numeric
25	Approved feed per tooth	Numeric
26	Approved average chip thickness	Numeric
27	Approved radial depth of cut	Numeric
28	Approved axial depth of cut	Numeric
29	Approved radial passes	Numeric
30	Approved axial passes	Numeric
31	Approved tool life	Numeric
32	Approved vibration record	Numeric
33	Approved chip quality	Numeric
34	Approved problems (free form text)	Character
35	Approved notes	Character

Table 7.1: Approved data structure

For comparison purposes, it is desirable to store approved data that tallies with the data generated by the main cutting parameters module and include additional data about any extraordinary problems that occur. Other more subjective data can be included as either a sequence of codes (for instance, describing the level of noise pollution) or a free form description in text format. Finally, reference information describing the machine tool, the cutter/insert combination and the component details is required to enable selective analysis later on. A sample approved data set for a milling operation is shown in Table 7.1.

7.3 Data acquisition methods

Generally, the final working cutting data for a given milling operation is stored in the part program. The increasing levels of automation introduced with CNC machining centres and integrated CAM systems offer considerable potential for automatic retrieval and storage of the final cutting data. Most CAM systems feature a database of process plans and this could be interrogated to extract the exact operation geometry and cutting conditions used on a particular component. Recent developments in Distributed Numerical Control (DNC) [Toh & Newman (1995)] would enable the transmission, to a central computer in real time, of information relating to the performance of the machine tool and in particular any problems encountered with the suggested cutting data from the process plan such as excess vibration, insufficient power or unsatisfactory chip forming. Thus, it would be possible to automatically extract the suggested cutting data from the process plans database and the approved data from a DNC link.

Unfortunately, many machining environments are not controlled by a CAM/DNC system and probably the most suitable data acquisition method for these situations is manual recording, either on paper or into a computer based data management system. The OPTIMUM system is currently not linked to a specific CAM system and thus it includes a data entry and management system that is used to maintain all the data tables of the system. This is used to input approved data against the appropriate suggested data. As demonstrated in the design of the machinability assessor, it is important to make this data entry process as simple as possible. Fields consisting of short codes can be filled from a list of possible codes. The approved cutting data fields can initially be filled with the

values of the suggested cutting data (it is likely that some of this cutting data will not have been altered as machine operators often only modify one cutting parameter at a time). A level of feasibility checking can be applied to this approved cutting data by comparing it to the suggested data - any excessive differences can be flagged for confirmation by the user. All the approved data described in Table 7.1 is stored in a single approved database.

7.4 Conformance assessment methods

A large data table of suggested cutting data and the associated approved data is a valuable resource for refining the performance of an algorithmic CAPP system. Any method of analysis of the differences between the two data sets must be of a form that can be easily applied to the future output of the CAPP system to enhance accuracy and consistency. The relationship between the optimized cutting data output from the CAPP system and the approved data is likely to be complex as it can be a result of either weaknesses in the machining model being used or the stochastic variation of dependent process variables. To model precisely all the relevant processes occurring during even a simple machining operation is widely held to be beyond the scope of simple mathematical modelling with characteristic equations. Two promising approaches to the assessment of conformance between suggested and approved data are statistical analysis and non-deterministic modelling.

7.4.1 Statistical methods

As shown in the machinability assessment method described in Chapter 4, simple statistical methods may be usefully employed to derive relationships between independent and dependent variables for machining. If there is sufficient approved data available then multiple regression may be used to perform curve fitting between the suggested values and the approved values for a given process parameter. Whilst this process is numerically simple to achieve, the definition of which records in the approved data table are sufficiently similar to the operation under consideration to merit inclusion in the regression analysis is a problematic task. The similarity between the setup of the approved operation and the current operation must be high enough to produce a characteristic relationship between approved and suggested data yet relaxed enough to include enough approved data to perform a statistically significant analysis. Maropoulos

and Gill (1995) suggest a set of similarity criteria that may be used to extract approved data records for turning operations. The two extremes of approved data record matching are:

1. Perfect matching

Approved cutting data will be extracted only for the same operation performed on the same workpiece material by the same cutting tool on the same machine tool. Despite the fact that *this is likely to give the most precise and consistent results*, a large amount of very similar data is required to perform non-trivial analyses for a useful range of tools, materials and operation types.

2. Partial matching

With this form of matching criteria, not all of the identifying parameters mentioned above need to be the same. As any given approved data record is more likely to match the criteria than for perfect matching, this form of matching allows analysis to be performed on considerably smaller approved data tables than for perfect matching. It is desirable for the matching criteria to be relaxed first in relation to the machining parameters that are least likely to affect the overall relationship between suggested and approved data. As the machine tool critically affects the available power, this is a good choice to be a match. The type of workpiece material, combined with its surface conditioning, can greatly influence the feasible cutting data so some form of matching by material group is desirable. Whilst it is difficult to equate the response of tools used for widely differing operations, for any given type of operation the machining response is often similar for a range of tools. So approved data may be usefully analyzed whilst being grouped by operation type. A description of the partial matching criteria used in the OPTIMUM system is included in the following section.

7.4.2 Conformance assessment implementation

The conformance assessment method implemented in the OPTIMUM system performs regression analysis on the approved data tables. This analysis is performed in real time on a subset of the approved data table that is extracted by applying the following criteria:

- Suggested Machine Number = Approved Machine Number
- Suggested Material Group = Approved Material Group
- Suggested Machinability Group = Approved Machinability Group
- Suggested Operation Type = Approved Operation Type

These four matching criteria were chosen to provide close matching of approved data records without requiring perfect matches. The machine tool can critically affect the process parameters that can be employed on a given component. Many constraints on the cutting data are determined by the machine tool, such as available power, table feed range, spindle speed range, overall component size, workholding features and tool size. Therefore it is important that extracted approved records should be for the same machine tool as the operation under consideration. Similarly, the workpiece material influences the overall level of cutting data that is generated. Thus, the approved records are matched on both material group and machinability group. Finally, the type of milling operation defines the types of cutters that may be used and the critical dimensions of those cutters. As the type of cutter constrains the cutting data used, this is the fourth matching criterion.

Some other possible matching criteria are not included. The exact cutter designation or the less precise cutter family designation is not used as many different cutters can perform in similar ways for a particular milling operation. The dimensions of the operation and the cutter are not considered as a large amount of approved data for many different sizes of operation would be required to produce reliable data matching for the full range of available tools. As more approved cutting data is gathered it would be possible to introduce some cutter dimensions, such as effective diameter, as an additional matching criterion. This would provide a more refined conformance assessment process.

The regression analysis is performed on four of the major cutting parameters: cutting velocity, feed per tooth, axial depth and radial depth. As the axial and radial depths of cut are functions of the operation and tool geometry, they are not likely to be adjusted during the cutting data approval process. However, it is to be expected that, when attempting aggressive, optimized cutting data, some modification of the cutting velocity and/or the feed per tooth may be necessary. The conformance assessment method is applied to one set of cutting data at a time, selected by the user. If the approved data that matches the given operation by the aforementioned matching criteria is insufficient for a full regression calculation, the process fails gracefully. A third order polynomial curve fit is calculated for each of the four major cutting parameters. An example of a regression curve generated for cutting velocity for facing operations on cast carbon steel is shown in Figure 7.2.

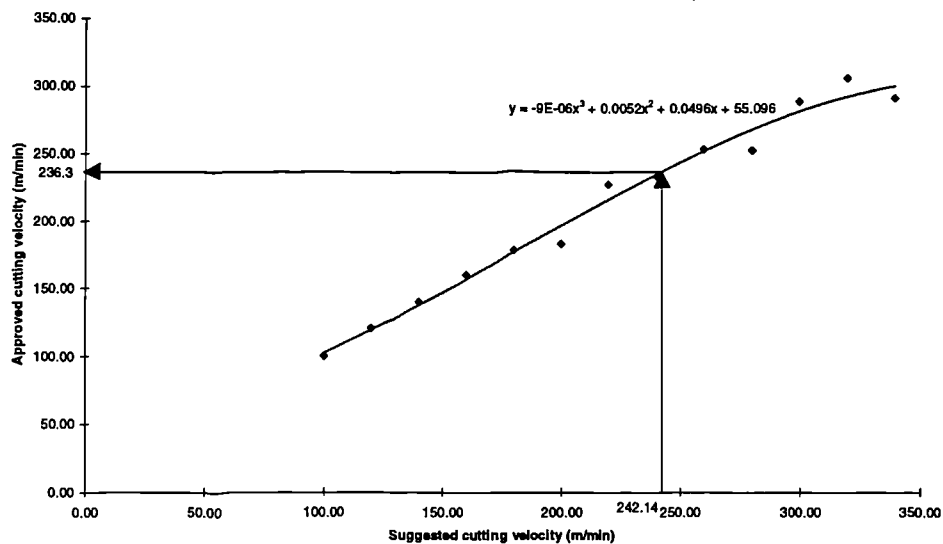

Figure 7.2: Multiple regression curve fitting for cutting velocity conformance assessment

A modified cutting velocity value is generated by evaluating the polynomial function of the curve fit with the suggested cutting velocity. For example, a suggested cutting velocity of 242.14 m/min produces a modified value of 236.35 m/min, as shown by the arrows in Figure 7.2.

The full set of adjusted cutting data is presented as shown in Figure 7.3 (the suggested data is the cutting data for the selected tool in Example 12 of Chapter 8). As might be

expected, the cutting velocity and feed per tooth are both reduced slightly whilst the axial and radial depths of cut remain unchanged. A worked example of the conformance assessment process is presented in Chapter 8.

Conformance Assessment	
Component:	Chapter 8 tests
Operation:	Face 200.0mm wide by 200.0mm long by 1.00mm deep
Material:	carbon steels, cast - All sub-groups - 150 HB
Machine:	FLEXIMATIC FM300
Cutter:	R22013825012C
Insert:	SENN120308TM12T25M
Initial data	
Velocity:	242.14 m/min
Feed per tooth:	0.50 mm
Axial depth:	1.00 mm
Radial depth:	100.00 mm
Adjusted data	
Velocity:	236.35 m/min
Feed per tooth:	0.45 mm
Axial depth:	1.00 mm
Radial depth:	100.00 mm
<input type="button" value="OK"/> <input type="button" value="Cancel"/> <input type="button" value="Help"/>	

Figure 7.3: Adjusted cutting data from conformance assessment method

It is worth noting that for such a curve fitting exercise to be significant, at least four distinct matching approved data records are required. When considering the wide range of machine tools, workpiece materials and milling operations that may be encountered in a machine shop, a substantial amount of approved data must be collected for the conformance assessment module to perform well in a wide range of situations. Fortunately, a well utilized machine tool is producing approved data almost continuously. However, an efficient data gathering and storage method is critical to the efficient use of approved data and the manual data entry method currently implemented in OPTIMUM may become impractical in manufacturing environments with a high variety of machining centres, cutting tools and workpiece geometries. A direct interface with an established DNC system would provide a fertile area for new research in producing robust and industrially relevant cutting data generation.

7.4.3 Modelling of stochastic behaviour

The mechanical, thermodynamic and chemical processes that occur during metal cutting are, to this day, still not fully modelled and most attempts to mathematically model the machining process have involved considerable simplifications in order to increase applicability and robustness. However, certain parameters are more easily analyzed than others and mathematical modelling of the major cutting parameters (cutting velocity, feed, depth of cut) can provide useful initial optimized cutting data. Some machining responses are rather more complex or difficult to predict. For instance, the onset of chatter may be caused by a variety of factors such as tool deflection, workpiece deflection or built-up edge effects. Although the useful tool life is used as the expression of the cutting data objective function, it is highly susceptible to scatter and often suffers from poor repeatability [Kuljanic (1980), Zompi (1979)]. These stochastic characteristics may be investigated using modern non-deterministic methods such as genetic algorithms or neural networks.

Neural networks are “*massively parallel interconnected networks of simple (usually adaptive) elements and their hierarchical organizations which are intended to interact with objects of the real world in the same way as biological nervous systems do*” [Kohonen (1988)]. A typical neural network structure is shown in Figure 7.4.

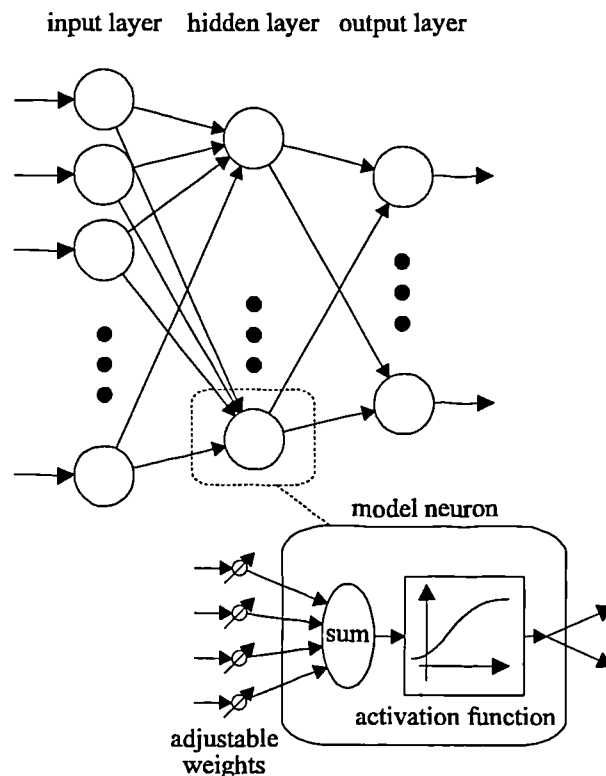

Figure 7.4: General structure of a neural network

Neural networks are well suited to input of a numerical nature or a simple range of discrete values. For example, chatter may be enumerated onto a scale of 1 to 10 with 1 representing negligible chatter and 10 representing catastrophic chatter.

A possible configuration for a neural network for conformance assessment would be eight input nodes, four output nodes and one hidden layer of seven nodes. The input and output nodes could be configured as shown in Table 7.2.

Input node	Description
1	Machine
2	Material group
3	Machinability group
4	Operation
5	Cutting velocity
6	Feed per tooth
7	Axial D.O.C.
8	Radial D.O.C.

Output node	Description
1	Cutting velocity
2	Feed per tooth
3	Axial D.O.C.
4	Radial D.O.C.

Table 7.2: Neural network input and output nodes

Although there is currently considerable interest in applications of neural networks to manufacturing problems, some of the scientific and economic expectations of neural networks are unreasonable. Huang and Zhang (1995) suggest that the main drawbacks of neural networks are:

1. The configuration of a neural network is usually time consuming, as one needs to use a trial-and-error method to find the proper neural network architecture for a given problem.
2. The knowledge representation of a neural network is vague and not easily understood.
3. A neural network cannot explain its results explicitly, which implies that the user interface of a neural network may not be as friendly or productive as that of, say, an expert system.
4. The current neural network learning algorithms are not efficient enough and cannot guarantee network convergence.
5. How to derive some type of optimal training set for a neural network application still remains a problem.

Neural networks are becoming a commonly used tool for the modelling of complex processes. Published literature describes applications of neural networks which include cutting data generation [Wang (1993a, 1993b), Narayanan (1995)], modelling of workpiece vibration [Tansel *et al.* (1993a)], chatter prediction [Tansel *et al.* (1993b), Tarnng & Chen (1994)] and tool condition monitoring [Burke & Rangwala (1991), Tarnng *et al.* (1994)]. The application of neural networks to cutting data conformance assessment for milling presents an interesting scenario for future research work.

7.5 Data availability

In any consideration of the use of approved cutting data, it is important not to forget some of the factors that affect the availability of such approved data. Any CAPP system that optimizes cutting data is likely to produce process parameters that are more aggressive than the standard cutting data used in most manufacturing companies. In order to obtain useful approved data, this aggressive cutting data must be used on the appropriate machine setup. Any changes that are required to achieve satisfactory cutting should be recorded in the approved data. This is a process that inevitably has some risk associated with it as there is a realistic chance of the machining operation failing. In normal manufacture there are many paradigms of failure such as premature tool failure, poor surface finish, out of tolerance geometry and workpiece damage. For these reasons, it is important to build a good relationship between the research team and the industrial collaborator.

A process of testing and approved data collection has been performed for turning in two companies in the north-east of England [Lewis (1995)]. This work has demonstrated the principle of using approved data to enhance the conformance of a generative cutting data algorithm. A similar program of testing for this milling algorithm offers considerable scope for a future experimental research project.

Chapter 8

Testing and results

This chapter contains a selection of examples to demonstrate the various capabilities of the OPTIMUM system. Whilst much of the system has initially been designed for use by a tool manufacturer, it is hopefully sufficiently flexible to be useful in any process planning department where there is rapid turnaround of components and tool selection can be problematic (typically in a small batch or jobbing shop environment).

The following examples are divided into four sections. The first contains samples of the output of the machinability assessment module. The second section consists of examples of the output of the tool selection and cutting data optimization module. The third section presents the results of a tool variety reduction exercise and the fourth section features a worked example of a conformance assessment procedure.

8.1 Machinability assessment examples

In order to test the ability of the machinability assessor to function using varying amounts and levels of detail of input data, the test operations are taken from real field test reports generated by engineers from Seco Tools, UK. These field tests are carried out at customers' premises and are often used to demonstrate the superior performance and lower cost of a Seco tool set over the standard tool set being used. Field tests are also a vital element of the process of introduction of a new tool into the marketplace. These field test reports feature a wide variety of recorded data. It is interesting to note that, even with a standard data collection form as used by Seco, the data obtained can vary considerably in accuracy and completeness.

It is also worth considering how these field tests are conducted. Generally, the tool engineer does not try to achieve optimum cutting conditions immediately but rather, a process of gradual adjustment is used to try to achieve cutting parameters that give a higher performance than the standard data in use at that particular facility. The main parameter that is varied is cutting velocity. Feed per tooth is generally set to a conservative value that is expected to be safe and then the cutting velocity is altered. One of the main advantages of a CAPP system is that it is possible to manipulate many independent variables to produce optimized data, a feat that is difficult to achieve manually.

The machinability assessment method presented in this thesis is designed to provide advisory initial cutting data from a varied amount of input data. The data tables currently used to interpolate this data [Metcut Research Associates (1980)] contain conservative cutting data. This is partly due to the *advances in tool design and carbide technology* since the publication of this data source and partly due to the requirement for cutting data in handbooks to offer a wide range of applicability. Thus, there are three main differences between the cutting data generation method employed in the machinability assessor and traditional cutting data optimization algorithms. Firstly, the quality and quantity of the input data to the machinability assessor may be low. Secondly, the cutting data output will always be conservative rather than aggressive. Thirdly, the generated cutting parameters are non-specific in that a particular cutter and insert grade are NOT suggested.

Whilst these three factors may be seen to be advantageous when performing tool calculations at a conceptual design stage or when complete input data is not available, they also make verification difficult. Cutting data from the machinability assessor is not expected to be exactly the same as optimized data or even cutting data found from field tests. Rather it is designed to give a reasonable starting figure. If the risk of using speculative data of this form is too great then obviously more complete input data is required so that a complete optimization and tool selection procedure can be executed.

As with all computer programs, the quality of the output data is always a reflection of the quality of the input data.

The following sections give examples of field test data along with the corresponding machinability assessment data and optimized cutting data generated by the tool selection algorithm for comparison purposes. The optimized data is for a constant tool life of 15 minutes and several different levels of harshness.

8.1.1 Example 1

Operation	Facing	Machine	KA0-Ming
Material	Rolled Steel Section	Power	35HP
Hardness	170BHN	Condition	Average
Seco Group	2/3	Coolant	Dry

a_a (mm)	B (mm)	L (mm)
5	102	-

Cutter No.	R220.13.0125.12C
Inserts	SEKN 1203 AFTN
Wipers	M14 T25M

	v (m/min)	n (rpm)	s_z (mm)	h_{zm} (mm)	m (cm ³ /min)
Field test	250	636	0.199	-	-
Machinability assessment	184	-	0.39	-	-
100% harshness	224	570	0.46	0.19	318.76
50% harshness	240	611	0.35	0.15	260.44
1% harshness	287	730	0.17	0.07	153.52

Table 8.1: Example 1

This example has a fairly complete set of data, including a surface hardness although not a precise material description. The total length of cut is often not recorded, as can be seen here. The machinability assessment module has produced a conservative cutting velocity and a larger value of feed per tooth. The machinability data is probably feasible but is not close to the field results because it is not calculated for a specific cutter and insert combination. As previously mentioned, field tests do not tend to produce high values of feed per tooth and this often accounts for rather low quoted values of s_z and correspondingly higher values of cutting velocity. However, it is interesting to note that the low harshness optimized cutting data is close to the field test results. The cutting data

for 50% and 100% harshness produces, as expected, much higher values of feed per tooth along with a reduction in cutting velocity.

8.1.2 Example 2

Operation	Sq. shoulder
Material	Stainless steel
Hardness	150BHN
Seco Group	

Machine	Rigid Rorschach
Power	22kW
Condition	Good
Coolant	

a_a (mm)	B (mm)	L (mm)
4.5	30	78

Cutter No.	R220.690063-16G
Inserts	APKR 1604PDR-76 T25M
Wipers	

	v (m/min)	n (rpm)	s_z (mm)	h_{2m} (mm)	m (cm ³ /min)
Field test	180	-	0.074	-	-
Machinability assessment	93	-	0.17	-	-
100% harshness	189	955	0.26	0.16	439.64
50% harshness	203	1024	0.19	0.12	353.72
1% harshness	239	1206	0.10	0.06	212.63

Table 8.2: Example 2

An imprecise material description is provided along with a surface hardness. The material group selected was number 13, 'stainless steels, wrought' with no specific machinability group specified. As before, the machinability assessment values are conservative with a slightly higher value of feed per tooth (the unusual feed per tooth used in the field test suggests that the machine tool may only have a limited range of feed rates). Again, the low harshness optimized data is rather closer to the field test results.

8.1.3 Example 3

Operation	Sq. shoulder
Material	Group 9 SS
Hardness	
Seco Group	9

Machine	MAHO
Power	10-12kW
Condition	Good
Coolant	

a_a (mm)	B (mm)	L (mm)
5	75	-

Cutter No.	R220.17-0100
Inserts	TPKR 2204PDTR-76 T25M
Wipers	

	v (m/min)	n (rpm)	s_z (mm)	h_{zm} (mm)	m (cm ³ /min)
Field test	134	405	0.15	-	-
Machinability assessment	76	-	0.18	-	-
100% harshness	127	403	0.32	0.18	119.62
50% harshness	208	662	0.21	0.12	131.03
1% harshness	191	608	0.11	0.06	61.33

Table 8.3: Example 3

Very little material data is provided for this test piece, beyond the fact that it is a stainless steel in Seco material group 9. The machinability assessment gives a lower cutting velocity and a slightly more aggressive feed per tooth. In the standard cutting data tables feed per tooth is generally set at one of a discrete set of values, rather than varying continuously, and this makes it difficult to smoothly interpolate new values of s_z . The large difference between the suggested cutting velocity and the field test value may be caused by an artefact of the cutting philosophy that was used to produce the initial machinability data (from the *Machining Data Handbook*). Stainless steel can be successfully cut in two ranges of cutting velocity, one low in value and the other much higher. Recently, tool manufacturers have tended to suggest cutting at much higher velocities than was common when the *Machining Handbook* was published (1980), presumably in order to exploit the higher rates of metal removal that are achievable with modern carbide grades. The addition of more company specific data to the cutting data tables would tend to reduce these apparent discrepancies. The optimized cutting solutions tend to give a higher cutting velocity and feed per tooth than the field test. This is likely to be a result of the optimization process that will tend to use all available

power, although full details of the machine tool used in the field test were not available. The optimized data with harshness levels of 50% and 100% gives cutting data with considerably higher values of feed per tooth than are likely to be attempted in a field test, although these values are within the capability of the given cutter/insert combination.

8.1.4 Example 4

Operation	Facing
Material	S/Steel 304
Hardness	
Seco Group	9

Machine	Giddings Lewis & Fraser
Power	Adequate
Condition	Average
Coolant	Dry

a_a (mm)	B (mm)	L (mm)
2	50	3650

Cutter No.	R220.13.0125-12
Inserts	SEKN 1203 AFTN T25M
Wipers	

	v (m/min)	n (rpm)	s_z (mm)	h_{zm} (mm)	m (cm ³ /min)
Field test	140	-	0.15	-	-
Machinability assessment (135 BHN)	201	-	0.30	-	-
Machinability assessment (185 BHN)	185	-	0.28	-	-
Machinability assessment (235 BHN)	164	-	0.23	-	-
100% harshness	131	334	0.53	0.22	124.72
50% harshness	145	370	0.35	0.15	91.07
1% harshness	173	442	0.17	0.07	52.48

Table 8.4: Example 4

The specified material, stainless steel 304, is classified as a wrought austenitic stainless steel. As no figure for surface hardness is provided, the assessor provides a set of cutting data for the range of expected hardness values for this material group (135-235 BHN). The worst case scenario is the highest surface hardness and this presents cutting data that is comparable, although a little higher, to the final result of the field test. The other preliminary cutting data presented in the field test report is lower than the final cutting data so it seems likely that the eventual values were not arrived at by a process of reduction.

8.1.5 Summary

These examples demonstrate the ability of the machinability assessment module to produce initial cutting data even when presented with input data of low accuracy or partial completeness. This method may be used to obtain process parameters when input data is sparse or difficult to obtain, such as in the remote technical support of tooling or in the early conceptual design stages of the product cycle as an aide to concurrent engineering. Presently most cutting data for technical support is derived from tool manufacturers' documentation or from field tests conducted in customers' manufacturing facilities. As previously mentioned, these field test results tend to be the result of a process of satisfaction rather than optimization and they are subject to some interpretation about how the various process parameters are varied to improve cutting performance.

The machinability assessor has been shown to work effectively with a variety of input data. Precise verification is difficult due to the often imprecise nature of the input data. Further comparison with specific machining environments may provide some clues as to possible weaknesses in the data tables that are used to interpolate the new machinability parameters. However, due to the data driven design of the software, enhanced performance can easily be achieved by merely updating these data tables from more up-to-date or comprehensive sources. In any given manufacturing environment, verified cutting data is freely available from process plans and NC programs. The cutting data tables currently used by the system are intended to provide a reasonable starting point so that the machinability assessor can be used during the initial period when more specific approved cutting data is gathered.

8.2 Tool selection examples

Several examples of the cutting data optimization and tool selection procedure are presented in this section as a basis for discussion and also to illustrate the capabilities of the algorithm.

Currently, the cutters data table contains 532 different cutters and the inserts table contains 3819 inserts. These tables were automatically derived from a machine readable

copy of the Seco Tools catalogue and the cutter and insert prices were added manually from the current price lists. The relational data table that links the two tables (allowing a one to many relationship between cutters and inserts) was derived from the Seco Tools UK quoting system. This provides a total of 35,988 possible different tools i.e. cutter/insert combinations.

Two machines are included in these examples: a medium powered EMCO VMC-200 Vertical machining centre (10kW) and a more powerful Fleximatic FM300 (18kW). These have been chosen to demonstrate the power and physical size constraints placed upon the cutting process by the machine specification. All the machine details have been obtained from the catalogues of machine tool manufacturers.

Four workpiece material types have been considered: cast carbon steel, wrought tool steel, wrought free machining alloy steel and cast stainless steel. If not specified, all the example program output has been generated for cast carbon steel and optimized for the maximum production rate with 0% harshness (this makes it easier to compare with catalogue data). All the tool sorting has been performed with equal weighting (25%) on maximum production rate, maximum tool life, minimum cost and minimum machining time. The sample tool list outputs have been generated directly from the results data tables and show detailed parameters for the top tool and critical parameters for the other suboptimal tools in the tool list. The number of tools has been limited to demonstrate the major characteristics of the tool selection procedure and also to provide tool lists short enough to print on one page (with all cutters and inserts marked as available, a simple facing operation can produce a tool list with more than 300 feasible tools!). As the program outputs fills about a page for each tool selection procedure, the results are grouped together at the end of this section, starting on page 181.

8.2.1 Examples 5 and 6: Geometric constraints

These examples are in relation to the machining of a simple slot as shown in Figure 8.1.

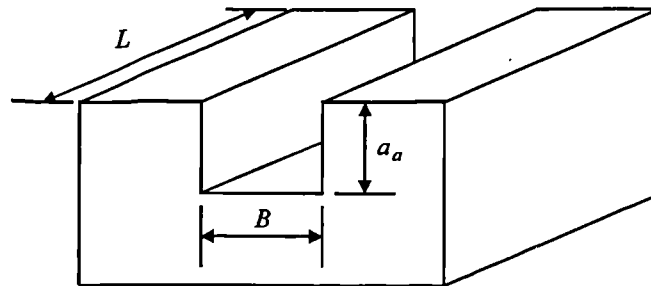

Figure 8.1: Example slotting operation geometry

The operation and tool selection details are as follows:

Material	Carbon steel, cast - 150BHN
Machine	Fleximatic FM300
Operation type	Straight slot
Dimensions	
L	200 mm
B	40 mm
a_a	9 mm

Cutting data optimization criteria	
Optimization method	Maximum production rate
Cutting data harshness	0%
Tool selection criteria	
Maximum metal removal rate	85%
Maximum tool life	5%
Minimum overall cost	5%
Minimum overall time	5%

A summary of the results of the tool selection process is shown in Table 8.5. The tools are sorted largely by metal removal rate in order to accentuate the effect of cutter size and depth of cut on the tool selection process. The selected tool is the largest feasible tool that can perform the operation, with a 40mm cutting diameter, thus giving the fewest number of axial and radial passes. It is interesting to note that, although a coated insert grade such as T25M is often suggested for milling carbon steel, a similar but uncoated grade, S25M, can be used to produce a higher metal removal rate, albeit with a reduced tool life. Smaller cutters with diameters of 32mm and 25mm appear further down the tool list. Example 6 is the same as the previous one but with the slot depth

being increased from 9 mm to 13 mm. Table 8.6 shows that the selected tool is now different to that given previously because the maximum depth of cut constraint has reduced the performance of the largest tool. In this case, the smaller 32 mm tool can still cut the slot in one axial pass although two radial passes are required to achieve the specified slot width. This is shown to remove material faster than with two radial passes and two axial passes when using the larger 40 mm cutter.

8.2.2 Example 7: Pocket milling constraints

For this example, the operation being considered is a rectangular pocket of the form shown in Figure 8.2.

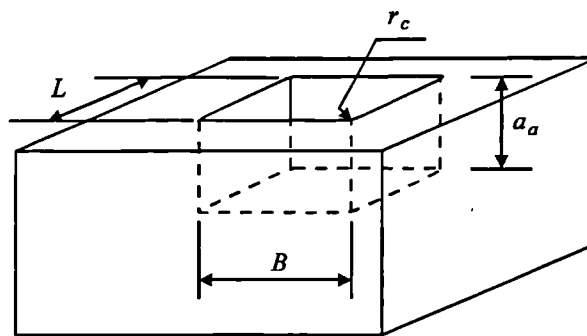

Figure 8.2: Example pocket operation geometry

The operation and tool selection details are as follows:

Material	Carbon steel, cast - 150BHN
Machine	Fleximatic FM300
Operation type	Closed pocket
Dimensions	
L	200 mm
B	50 mm
a_a	5 mm
r_c	18 mm

Cutting data optimization criteria	
Optimization method	Maximum production rate
Cutting data harshness	0%
Tool selection criteria	
Maximum metal removal rate	25%
Maximum tool life	25%
Minimum overall cost	25%
Minimum overall time	25%

The output of the system is shown in Table 8.7. For closed pockets, a sample set of plunging parameters are calculated and only tools that are capable of plunging are considered. The cutters that are capable of performing plunging cuts have the single letter code for plunging, L, associated with them in the cutters data table. Suggested plunging cutting data has been generated as described in Chapter 5. As seen in the previous two examples, closed pocket milling is decomposed into two sub-operations: the first full immersion pass followed by the evenly spaced, partial immersion radial passes. For subsequent passes, fewer cutting edges are simultaneously engaged in the cut and thus it is feasible to use slightly higher cutting data to produce the same tool life objective as for the first pass. The corner radius of 18 mm restricts the maximum possible diameter of cutter and thus all the 40 mm and 50 mm cutters are disregarded. With the tool list sorting criteria evenly distributed over the four sorting parameters, coated carbide grades (those beginning with a 'T') tend to give slightly better performance than uncoated grades (those beginning with an 'S').

8.2.3 Examples 8 and 9: Available power limitation

A facing operation of the form shown in Figure 8.3 is used to demonstrate the influence of the machine power on the cutting conditions optimization.

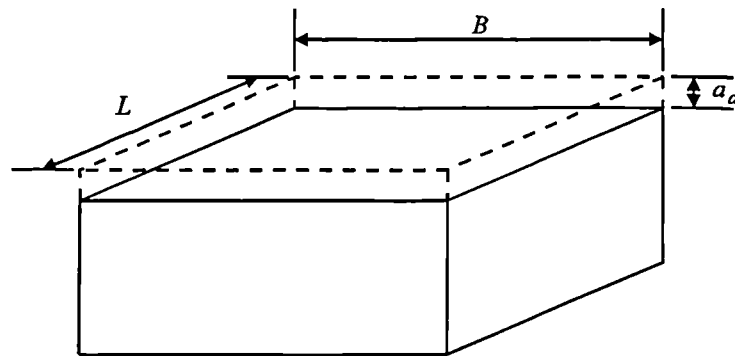

Figure 8.3: Example facing operation geometry

Example 8 is of the following form:

Material	Carbon steel, cast - 150BHN
Machine	Fleximatic FM300
Operation type	Facing
Dimensions	
L	400 mm
B	200 mm
a_d	4 mm

Cutting data optimization criteria	
Optimization method	Maximum production rate
Cutting data harshness	0%
Tool selection criteria	
Maximum metal removal rate	33%
Maximum tool life	1%
Minimum overall cost	33%
Minimum overall time	33%

No surface finish is specified i.e. it is a roughing cut. The results for Example 8 are shown in Table 8.8. Again, the largest feasible cutter is selected with a coated insert grade. Smaller cutters and less suitable insert grades appear further down the list as suboptimal tools. Example 9 is exactly the same as Example 8 except the chosen machine tool is the smaller 10kW EMCO VMC-200 Vertical machining centre. The lower power threshold in Example 9 means that the largest feasible tool, the 250 mm cutter selected for Example 8, must take two axial passes to reduce its power requirement. Of course, this increases the cutting time, lowers the metal removal rate and increases the cost, so the optimal tool for the Fleximatic machine appears some way down the tool list for the EMCO machine.

8.2.4 Examples 10 and 11: Feature decomposition

Some easily identified geometric features do not map onto just one machining operation. A good example of this is the T-slot, commonly encountered in machine tool manufacture. The geometry of a typical T-slot is shown in Figure 8.4. As well as possessing a slot depth and width, there is also a depth and width associated with the neck of the T-slot cutter, shown as ND and NW respectively in Figure 8.4.

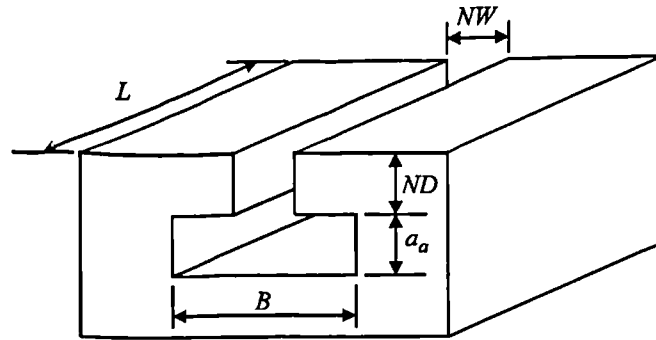

Figure 8.4: Example T-slot operation geometry

The details of Example 10 are as follows:

Material	Carbon steel, cast - 150BHN
Machine	Fleximatic FM300
Operation type	T-slot
Dimensions	
L	200 mm
B	32 mm
a_a	14 mm
ND	4 mm
NW	25 mm

Cutting data optimization criteria	
Optimization method	Maximum production rate
Cutting data harshness	0%
Tool selection criteria	
Maximum metal removal rate	25%
Maximum tool life	25%
Minimum overall cost	25%
Minimum overall time	25%

The cutting edges on a T-slot cutter are only present on its lower disc section and not on the neck. Thus, an initial plain slot, of width NW , must be cut to allow the neck of the T-slot cutter access into the workpiece whilst it cuts out the wide bottom slot geometry. The OPTIMUM system decomposes T-slot geometries into two machining operations: the initial plain slot and then the following T-slotting cut. It is debatable whether the initial slot should be to the full depth of the T-slot ($ND+a_a$) or just the depth of the neck (ND). The former will leave less material to be removed by the T-slot cutter (these can be quite expensive) but the number of cutting interruptions will be doubled to two per revolution as opposed to the single tool entry encountered when cutting with the full

width of a tool. Currently, OPTIMUM is configured to define a plain slot for the full depth of the T-slot although this can be easily changed.

The plain slot results are shown in Table 8.10 and the T-slot cutter selection results are given in Table 8.11. The geometric constraints on a T-slot cutter are considerable and only cutters that can fit completely into the lower slot void will be considered. Also the cutters must have a long enough neck to be able to reach the bottom of the slot and the neck must not be wider than the specified neck width.

8.2.5 Examples 12 and 13: Surface finish constraint

Whilst it is possible to attempt aggressive cutting strategies when performing roughing cuts, the final finishing cuts generally require more constrained process parameters. Possibly the most crucial constraint on finish machining is the surface finish that has been specified as this will actively constrain the maximum feed per tooth that can be used. Example 12 is for a finish facing operation of the following form:

Material	Carbon steel, cast - 150BHN
Machine	Fleximatic FM300
Operation type	Facing
Dimensions	
L	200 mm
B	200 mm
a_a	1 mm
R_a	10 μm

Cutting data optimization criteria	
Optimization method	Maximum production rate
Cutting data harshness	100%
Tool selection criteria	
Maximum metal removal rate	25%
Maximum tool life	25%
Minimum overall cost	25%
Minimum overall time	25%

To emphasise the effect of the surface finish, both of these examples are for maximum production rate but with a harshness level of 100%. This has the effect of increasing the initial feed per tooth to the maximum allowable for the cutter/insert combination. Example 12 with a surface finish of 10 μm produces the output shown in Table 8.12. In Example 13, the surface finish is reduced to 1 μm . This finer surface finish heavily limits

the feed per tooth, as shown in Table 8.13. For the same objective function, this lower feed per tooth results in a considerably lower metal removal rate and, consequently, increased total time and cost.

8.2.6 Examples 14, 15, 16 and 17: Effect of workpiece material

The influence of workpiece material can be seen in these four examples. The operation under consideration is a square shoulder, of the form shown in Figure 8.5.

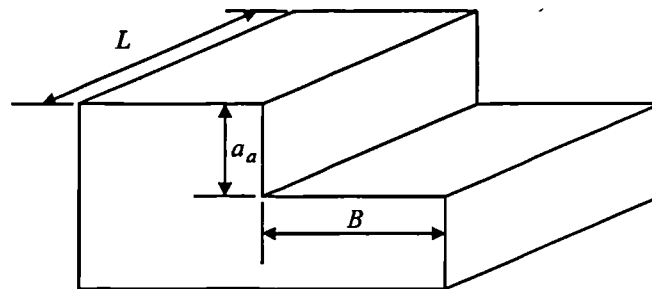

Figure 8.5: Example square shoulder geometry

The operation and tool selection details for these examples are as follows:

Material	Carbon steel, cast - 150BHN Tool steels, wrought - 320 BHN Free machining alloy steels, wrought - 320 BHN Stainless steels, cast - 290 BHN
Machine	Fleximatic FM300
Operation type	Square shoulder
Dimensions	
L	200 mm
B	80 mm
a_a	5 mm

Cutting data optimization criteria	
Optimization method	Maximum production rate
Cutting data harshness	0%
Tool selection criteria	
Maximum metal removal rate	25%
Maximum tool life	25%
Minimum overall cost	25%
Minimum overall time	25%

The tool selection procedure has been executed for four different workpiece materials and the results are summarized in Tables 8.14 to 8.17. As chip capacity is not implemented as an active constraint, the different chipping characteristics of these

workpiece materials does not directly affect the choice of cutter. However, the choice of insert grade and the constants in the tool life objective functions are dependent upon workpiece material. For geometric reasons, the large 160 mm cutter is selected as the optimum cutter for each example. The main determinant for each example data set is the combination of the workpiece material and the insert grade. Tool steel is better cut with uncoated carbides whereas alloy steels, carbon steels and particularly stainless steels are easier to cut with coated grades. The preferred cutter geometry rules implemented in the tool selection module allow certain geometries of cutters to be excluded for specified material groups. In this case, square shoulder cutters must have an approach angle of 90°. However, most of the general Seco tools capable of performing square shouldering are suitable for a wide range of material types and this is borne out by the fact that the selected cutter in each of these examples is the same.

8.2.7 Examples 18 and 19: Effect of objective function and optimization criteria

Whilst most of the previous examples have been calculated for maximum production rate and 0% harshness, the OPTIMUM system does offer considerable flexibility in the specification of the objective functions used to optimize the cutting conditions. Example 18 concerns a facing operation (see Figure 8.3) of the following form:

Material	Carbon steel, cast - 150BHN
Machine	Fleximatic FM300
Operation type	Facing
Dimensions	
L	400 mm
B	400 mm
a_a	1 mm

For comparison purposes, cutting data for the same cutter and insert is presented for a range of objective functions. The cutter and insert are those that were selected for maximum production rate and 0% harshness - the standard Seco facing cutter R220.13-8250-12C with the SEKN1203AFN-E12 T25M insert.

The results are shown in Table 8.18. This example illustrates the difficulty in finding a so-called '*optimum*' tool and cutting conditions. The three main objective functions can all be applicable in different manufacturing situations yet considerable differences can be

found in the cutting data thus generated. As mentioned in Chapter 2, the current Seco milling guide [Seco Tools AB (1994)] provides cutting velocities for each family of cutters according to the Seco material group and a feed per tooth from a predefined set of discrete values (in this case, 0.1 mm, 0.2 mm and 0.3 mm). In addition, cutting data is presented from the milling data computer program distributed by Seco called MILDA. This program generates cutting data for a specified cutter/insert combination and operation geometry.

The maximum production rate criteria tends to produce cutting data that gives a high metal removal rate but often at the expense of cutting cost, as can be seen when compared to the data for minimum production cost. Fixing the expected tool life at a constant value tends to produce cutting data related proportionally to this tool life value, within the active constraints. The tool life calculated for maximum production rate is 31 minutes and the tool life for minimum production cost is 104 minutes. These tool life values are reinforced by the similar cutting data shown for constant tool life of 32 minutes and 130 minutes respectively. The cutting data for constant tool life also shows that the operation cost appears to reach a minimum for a tool life between 65 minutes and 195 minutes. The cutting data generated for maximum production rate compares well with that produced by MILDA, giving a metal removal rate up to 30% higher. Interestingly, the machinability assessor produces cutting data that is reasonably close to that produced by MILDA, without the benefit of a precise tool and operation specification.

The use of a harshness coefficient is new in cutting data optimization programs and allows the user to define the aggressiveness of the generated data. Setting the harshness to a high value (near 100%) tends to give high values of feed per tooth and the cutting velocity is adjusted downwards to satisfy the current objective function. However, even with 100% harshness, the cutter is performing with a feed per tooth that is within its specified chip handling range.

Example 19 is for a slotting operation of the following form (see also Figure 8.5):

Material	Carbon steel, cast - 150BHN
Machine	Fleximatic FM300
Operation type	Square shoulder
Dimensions	
L	200 mm
B	20 mm
a_a	4 mm

The tool considered consists of the cutter R220.69-0050-16 and the insert APFT 1604PDR-M13 T25M. The patterns shown in Table 8.19 are similar to those in the previous example. In this case the tool life for minimum cost was calculated as 27 minutes and this is reinforced by the costs shown for a range of fixed tool life values. Again, the cutting data for a fixed tool life of 65 minutes is similar to that suggested by the Seco handbook and the MILDA program. The machinability assessor suggests rather conservative data, probably due to the lack of precise input data being used.

8.2.8 Summary

The examples presented in this section have shown the complexity of a tool selection procedure for milling operations. Many simpler tool selection algorithms have been suggested but it has been shown that in order to reliably identify the active constraints for any given operation, a machining model that includes all the major process parameter constraints is required. The interaction of these constraints is often elaborate and difficult to visualize or express in a repeatable form for manual process planning. The assignment of 'weights' to certain tool and workpiece features can simplify this process although it is likely that there may be many situations where the heaviest 'weight' turns out to be irrelevant. Experience alone, while very valuable, cannot be enough to handle the wide range of tool and material behaviour that is encountered in modern manufacturing industry.

A cutting data optimization and tool selection system, such as the OPTIMUM system described in this thesis, can provide a useful aid for tool selection in any manufacturing situation without any requirement for extensive machining experience, as long as the input data is correct. The tool lists generated in the tool selection process can also

illustrate which factors are critically influencing the feasible cutting performance for any specific machining job. For the more experienced process planner or for 'what-if' analyses, the system offers a set of user defined criteria that guide the cutting data optimization process. Also a compound objective function is provided to define what performance identifiers are used to select the optimal tool. The goal of tool selection and cutting data generation in industry is rarely as simple as just maximum production rate or minimum production cost.

```
*****
Tool list number   : 1
Component name    : Chapter 8 tests
Operation         : Slot 44.00mm wide by 200.0mm long by 9.00mm deep
Workpiece material : carbon steels, cast - All sub-groups - 150 HB
Machine           : FLEXIMATIC FM300
Notes             : Slot 40.00mm wide by 200.0mm long by 9.00mm deep
*****
```

```
Selected tool
*****
Cutter           = R217.69-03040-13
Insert           = XCMX13T330TR-M11 S25M
Total cost       = £ 0.39
Axial passes     = 1
Axial D.O.C.    = 9.00 mm
Radial passes    = 1
Radial D.O.C.   = 40.00 mm
Cutting velocity = 293.92 m/min
Spindle speed    = 2338.96 RPM
Feed per tooth   = 0.09 mm
Av. chip thickness = 0.06 mm
Engagement angle = 3.14 mm
Metal removal rate = 317.44 mm
Power            = 15342.73 W
Tool life        = 6.95 min
Comment          = This is the initial full immersion slotting cut
Notes:
```

```
*****
Tool list
*****
```

Rank	Weight	Tool	Cost	Time	Tool life	MRR
1	12764.24	Holder R217.69-03040-13	0.39	0.23	6.95	317.44
		Insert XCMX13T330TR-M11 S25M				
2	11959.36	Holder R217.69-03040-13	0.41	0.24	9.45	299.11
		Insert XCMX13T308TR-M11 S60M				
3	9319.93	Holder R215.17-3032.2-16	0.25	0.14	3.78	233.07
		Insert TPKR1603PDTR-ME10 T25M				
4	7795.32	Holder R215.17-3032.2-16	0.28	0.16	3.72	198.30
		Insert TPKN1603PDTR-MD12 S10M				
5	7277.99	Holder R217.69-03040-13	0.64	0.36	7.55	200.58
		Insert XCMX13T330TR-M11 T25M				
6	7186.05	Holder R215.17-3032.2-16	0.25	0.17	3.48	184.23
		Insert TPGN160308 S25M				
7	6643.48	Holder R215.17-3032.2-16	0.33	0.19	4.72	173.58
		Insert TPKR1603PDTR-ME10 S60M				
8	5760.86	Holder R215.17-3025.2-11	0.38	0.27	3.48	160.10
		Insert TPGN110208 S25M				

Table 8.5: Example 5 results

```
*****
Tool list number   : 2
Component name    : Chapter 8 tests
Operation         : Slot 44.00mm wide by 200.0mm long by 13.00mm deep
Workpiece material : carbon steels, cast - All sub-groups - 150 HB
Machine          : FLEXIMATIC FM300
Notes            : Slot 44.00mm wide by 200.0mm long by 13.00mm deep
*****
```

Selected tool

```
*****
INITIAL PASS
Cutter           = R215.17-3032.2-16
Insert          = TPKR1603PDTR-ME10 T25M
Total cost      = £ 0.33
Axial passes    = 1
Axial D.O.C.    = 13.00 mm
Radial passes   = 1
Radial D.O.C.   = 32.00 mm
Cutting velocity = 431.62 m/min
Spindle speed   = 4293.40 RPM
Feed per tooth  = 0.09 mm
Av. chip thickness = 0.06 mm
Engagement angle = 3.14 mm
Metal removal rate = 336.66 mm
Power          = 16272.05 W
Tool life      = 3.78 min
Comment        = This is the initial full immersion slotting cut
SUBSEQUENT PASSES
Axial passes    = 1
Axial D.O.C.    = 13.00 mm
Radial passes   = 1
Radial D.O.C.   = 12.00 mm
Cutting velocity = 530.64 m/min
Spindle speed   = 5278.36 RPM
Feed per tooth  = 0.11 mm
Av. chip thickness = 0.06 mm
Power          = 8393.52 W
Tool life      = 3.12 min
Comment        = Subsequent partial immersion cutting passes
Notes:
*****
```

```
*****
Tool list
*****
Rank Weight   Tool                               Cost   Time   Tool life   MRR
1   10676.85  Holder R215.17-3032.2-16             0.33   0.18   3.78       336.66
                Insert TPKR1603PDTR-ME10 T25M
2   10557.38  Holder R215.17-3032.2-16             0.38   0.18   3.78       336.66
                Insert TPAN1603PPTN T25M
3   9851.80   Holder R217.69-03040-13              0.19   0.11   7.55       289.73
                Insert XCMX13T330TR-M11 T25M
4   8933.92   Holder R215.17-3032.2-16             0.37   0.21   3.72       286.43
                Insert TPKN1603PDTR-MD12 S10M
5   8231.25   Holder R215.17-3032.2-16             0.33   0.23   3.48       266.11
                Insert TPGN160308 S25M
6   8207.99   Holder R215.17-3032.2-16             0.40   0.23   3.48       266.11
                Insert TPKR1603PDTR-ME10 S25M
7   7788.62   Holder R217.69-03040-13              0.23   0.14   6.95       229.26
                Insert XCMX13T330TR-M11 S25M
8   7653.43   Holder R215.17-3032.2-16             0.43   0.24   4.72       250.72
                Insert TPKR1603PDTR-ME10 S60M
9   7304.23   Holder R217.69-03040-13              0.26   0.15   9.45       216.03
                Insert XCMX13T308TR-M11 S60M
10  1202.70   Holder R215.17-3025.2-11             1.18   0.82   3.48       115.63
                Insert TPGN110208 S25M
*****
```

Table 8.6: Example 6 results

```

*****
Tool list number   : 3
Component name    : Chapter 8 tests
Operation         : Pocket 50.00mm wide by 200.0mm long by 5.00mm deep
                  : with 18.0mm corner radius
Workpiece material : carbon steels, cast - All sub-groups - 150 HB
Machine           : FLEXIMATIC FM300
Notes             : Pocket 50.00mm wide by 200.0mm long by 5.00mm deep

Selected tool
*****
INITIAL PASS
Cutter            = R215.17-3032.2-16
Insert           = TPKR1603PDTR-ME10 T25M
Total cost       = £ 0.42
Axial passes     = 1
Axial D.O.C.    = 5.00 mm
Radial passes    = 1
Radial D.O.C.   = 32.00 mm
Cutting velocity = 431.62 m/min
Spindle speed    = 4293.40 RPM
Feed per tooth   = 0.09 mm
Av. chip thickness = 0.06 mm
Engagement angle = 3.14 mm
Metal removal rate = 129.49 mm
Power            = 6258.48 W
Tool life        = 3.78 min
Comment          = This is the initial full immersion slotting cut
SUBSEQUENT PASSES
Axial passes     = 1
Axial D.O.C.    = 5.00 mm
Radial passes    = 1
Radial D.O.C.   = 18.00 mm
Cutting velocity = 490.32 m/min
Spindle speed    = 4877.28 RPM
Feed per tooth   = 0.09 mm
Av. chip thickness = 0.06 mm
Power            = 3838.42 W
Tool life        = 4.03 min
Comment          = Subsequent partial immersion cutting passes
Notes:
Initial plunging parameters
=====
Chip thickness = 0.06 mm
Feed = 0.25 mm/min
Cutting velocity = 410.95 m/min
RPM = 4087.75 RPM
MRR = 197.25 cm3/min
Power = 7627.1 W

```

```

*****
Tool list
*****
Rank Weight   Tool                               Cost   Time   Tool life   MRR
1   1508.29   Holder R215.17-3032.2-16                 0.42   0.23    3.78       129.49
                Insert TPKR1603PDTR-ME10 T25M
2   1142.46   Holder R215.17-3032.2-16                 0.48   0.23    3.78       129.49
                Insert TPAN1603PPTN T25M
3   543.54    Holder R215.17-3032.2-16                 0.46   0.27    3.72       110.17
                Insert TPKN1603PDTR-MD12 S10M
4   342.15    Holder R215.17-3032.2-16                 0.42   0.29    3.48       102.35
                Insert TPGN160308 S25M
5   -377.35   Holder R215.17-3032.2-16                 0.53   0.30    4.72       96.43
                Insert TPKR1603PDTR-ME10 S60M
6   -2972.98  Holder R215.17-3025.2-11                 0.70   0.48    3.48       88.95
                Insert TPGN110208 S25M
*****

```

Table 8.7: Example 7 results

```

*****
Tool list number   : 4
Component name    : Chapter 8 tests
Operation         : Face 200.0mm wide by 400.0mm long by 4.00mm deep
Workpiece material : carbon steels, cast - All sub-groups - 150 HB
Machine           : FLEXIMATIC FM300
Notes             : Face 200.0mm wide by 400.0mm long by 4.00mm deep

```

```

Selected tool
*****
Cutter            = R220.13-8250-12C
Insert            = SENN120308-E10 T25M
Total cost        = £ 1.60
Axial passes      = 1
Axial D.O.C.     = 4.00 mm
Radial passes     = 3
Radial D.O.C.    = 66.67 mm
Cutting velocity  = 327.09 m/min
Spindle speed     = 416.47 RPM
Feed per tooth    = 0.20 mm
Av. chip thickness = 0.07 mm
Engagement angle  = 1.09 mm
Metal removal rate = 357.95 mm
Power             = 17301.04 W
Tool life         = 19.28 min
Comment          =
Notes:

```

```

*****
Tool list
*****
Rank Weight   Tool                               Cost   Time   Tool life   MRR
1   2076.05   Holder R220.13-8250-12C                 1.60   0.89   19.28      357.95
                Insert SENN120308-E10 T25M
2   1956.65   Holder R220.13-8250-12C                 1.67   0.90   25.59      354.29
                Insert SEKR1203AFN-E07 S10M
3   1227.13   Holder R220.13-8250-12C                 1.75   0.98   23.58      326.04
                Insert SENN1303AFTN-MD15 S25M
4   1052.20   Holder R220.13-8250-12C                 1.84   1.00   34.30      320.11
                Insert SEKR1203AFN-E07 S60M
5   -670.47   Holder R220.13-8160-12                  2.16   1.20   14.85      266.23
                Insert SENN120308-E10 T25M
6   -881.80   Holder R220.13-0125-15                  1.83   1.30   13.72      246.40
                Insert SENN150408 T25M
7   -1381.74  Holder R220.13-0100-12                  2.29   1.31   13.07      244.25
                Insert SENN120308-E10 T25M
8   -2141.03  Holder R220.13-8160-12                  2.52   1.42   14.71      226.04
                Insert SENN1303AFTN-MD15 S10M
9   -2852.10  Holder R220.13-0063-12                  2.65   1.55   10.68      206.24
                Insert SENN120308-E10 T25M
10  -2856.97   Holder R220.13-0100-12                  2.68   1.54   12.95      207.32
                Insert SENN1303AFTN-MD15 S10M
11  -3180.62   Holder R220.13-0125-15                  3.03   1.53   13.54      209.21
                Insert SEKR1604AFTN-ME16 S10M
12  -3353.84   Holder R220.13-0063-12                  3.09   1.55   10.68      206.24
                Insert SEAN1303AFTN-M14 T25M
13  -3374.77   Holder R220.13-0125-15                  3.21   1.53   13.54      209.21
                Insert SEAN1504ZZN-E15 S10M
14  -3661.95   Holder R220.13-0100-12                  2.92   1.68   12.28      190.34
                Insert SENN1303AFTN-MD15 S25M
15  -3778.04   Holder R220.13-0100-12                  3.04   1.69   15.60      189.17
                Insert SEKR1203AFN-E07 S60M
16  -3936.86   Holder R220.13-0125-15                  3.24   1.66   12.70      192.25
                Insert SEKN1504AFTN-M18 S25M
17  -4030.86   Holder R220.13-0100-12                  3.26   1.68   12.28      190.34
                Insert SEAN1203AFTN-M14 S25M
18  -4410.69   Holder R220.13-0063-12                  3.10   1.83   10.58      174.98
                Insert SENN1303AFTN-MD15 S10M
19  -6256.40   Holder R220.13-0040-12                  3.77   2.17   6.68       147.66
                Insert SENN120308-E10 T25M
*****

```

Table 8.8: Example 8 results

```
*****
Tool list number      : 5
Component name       : Chapter 8 tests
Operation            : Face 200.0mm wide by 400.0mm long by 4.00mm deep
Workpiece material   : carbon steels, cast - All sub-groups - 150 HB
Machine              : EMCO VMC-200
Vertical machining   : centre
Notes                : Face 200.0mm wide by 400.0mm long by 4.00mm deep
*****
```

```
Selected tool
*****
Cutter               = R220.13-0125-15
Insert               = SENN150408 T25M
Total cost           = £ 1.91
Axial passes         = 1
Axial D.O.C.         = 4.00 mm
Radial passes        = 5
Radial D.O.C.        = 40.00 mm
Cutting velocity     = 377.14 m/min
Spindle speed        = 960.37 RPM
Feed per tooth       = 0.19 mm
Av. chip thickness   = 0.07 mm
Engagement angle     = 1.20 mm
Metal removal rate   = 200.07 mm
Power                = 9670.11 W
Tool life            = 9.72 min
Comment              =
Notes:
```

```
*****
Tool list
*****
```

Rank	Weight	Tool	Cost	Time	Tool life	MRR
1	-900.97	Holder R220.13-0125-15	1.91	1.60	9.72	200.07
		Insert SENN150408 T25M				
2	-1083.47	Holder R220.13-0063-12	2.32	1.55	10.68	206.24
		Insert SENN120308-E10 T25M				
3	-1552.80	Holder R220.13-8160-12	2.55	1.61	9.54	198.33
		Insert SENN120308-E10 T25M				
4	-1564.94	Holder R220.13-0063-12	2.76	1.55	10.68	206.24
		Insert SEAN1303AFTN-M14 T25M				
5	-1741.51	Holder R220.13-0100-12	2.54	1.66	9.80	193.15
		Insert SENN120308-E10 T25M				
6	-1873.45	Holder R220.13-0100-12	2.56	1.68	12.28	190.34
		Insert SENN1303AFTN-MD15 S25M				
7	-2051.81	Holder R220.13-8160-12	2.67	1.70	11.53	188.14
		Insert SENN1303AFTN-MD15 S10M				
8	-2142.59	Holder R220.13-0125-15	2.89	1.66	12.70	192.25
		Insert SEKN1504AFTN-M18 S25M				
9	-2226.71	Holder R220.13-0100-12	2.90	1.68	12.28	190.34
		Insert SEAN1203AFTN-M14 S25M				
10	-2390.84	Holder R220.13-0100-12	2.70	1.78	11.16	180.03
		Insert SENN1303AFTN-MD15 S10M				
11	-2407.23	Holder R220.13-8250-12C	2.83	1.79	19.28	178.98
		Insert SENN120308-E10 T25M				
12	-2570.14	Holder R220.13-8250-12C	2.95	1.81	25.59	177.15
		Insert SEKR1203AFN-E07 S10M				
13	-2574.27	Holder R220.13-0125-15	3.06	1.73	11.20	185.08
		Insert SEKR1604AFTN-ME16 S10M				
14	-2598.22	Holder R220.13-0063-12	2.71	1.83	10.58	174.98
		Insert SENN1303AFTN-MD15 S10M				
15	-2781.11	Holder R220.13-0125-15	3.26	1.73	11.20	185.08
		Insert SEAN1504ZZN-E15 S10M				
16	-3291.06	Holder R220.13-8250-12C	3.08	1.96	23.58	163.02
		Insert SENN1303AFTN-MD15 S25M				
17	-3385.05	Holder R220.13-0100-12	3.10	1.96	14.17	163.54
		Insert SEKR1203AFN-E07 S60M				
18	-3552.53	Holder R220.13-8250-12C	3.26	2.00	34.30	160.06
		Insert SEKR1203AFN-E07 S60M				
19	-4334.93	Holder R220.13-0040-12	3.30	2.17	6.68	147.66
		Insert SENN120308-E10 T25M				

```
*****
```

Table 8.9: Example 9 results

```

*****
Tool list number   : 6
Component name    : Chapter 8 tests
Operation         : T-slot 32.00mm wide by 200.0mm long by 14.00mm deep
Workpiece material : carbon steels, cast - All sub-groups - 150 HB
Machine          : FLEXIMATIC FM300
Notes            : This is the first plain slotting cut for the following feature
                  T-slot 32.00mm wide by 200.0mm long by 14.00mm deep

```

Selected tool

```

*****
Cutter            = R215.17-3025.2-11
Insert           = TPGN110208 S25M
Total cost       = £ 0.81
Axial passes     = 2
Axial D.O.C.    = 9.00 mm
Radial passes    = 1
Radial D.O.C.   = 25.00 mm
Cutting velocity = 355.78 m/min
Spindle speed    = 4529.94 RPM
Feed per tooth   = 0.08 mm
Av. chip thickness = 0.05 mm
Engagement angle = 3.14 mm
Metal removal rate = 160.10 mm
Power            = 7738.24 W
Tool life       = 3.48 min
Comment         = This is the initial full immersion slotting cut
Notes:

```

```

*****
Tool list
*****
Rank Weight   Tool                               Cost   Time   Tool life   MRR
1   0.00      Holder R215.17-3025.2-11          0.81   0.56    3.48    160.10
                Insert TPGN110208 S25M
2   0.00      Holder R215.17-3025.2-11          0.81   0.56    3.48    160.10
                Insert TPGN110204 S25M
3   0.00      Holder R215.17-3025.2-11          0.81   0.56    3.48    160.10
                Insert TPUN110208 S25M
*****

```

Table 8.10: Example 10 results

```

*****
Tool list number   : 7
Component name    : Chapter 8 tests
Operation         : T-slot 32.00mm wide by 200.0mm long by 14.00mm deep
Workpiece material : carbon steels, cast - All sub-groups - 150 HB
Machine          : FLEXIMATIC FM300
Notes            : T-slot 32.00mm wide by 200.0mm long by 14.00mm deep

```

```

Selected tool
*****
Cutter           = R395.19-3232.4-14
Insert          = CCMX08T308-E07 T25M
Total cost      = £ 0.96
Axial passes    = 1
Axial D.O.C.   = 14.00 mm
Radial passes   = 1
Radial D.O.C.  = 32.00 mm
Cutting velocity = 431.62 m/min
Spindle speed   = 4293.40 RPM
Feed per tooth  = 0.09 mm
Av. chip thickness = 0.06 mm
Engagement angle = 3.14 mm
Metal removal rate = 181.28 mm
Power           = 17523.75 W
Tool life       = 3.78 min
Comment        = This is the initial full immersion slotting cut
Notes:

```

```

*****
Tool list
*****
Rank Weight   Tool                               Cost   Time   Tool life   MRR
1   1339.35   Holder R395.19-3232.4-14           0.96   0.49   3.78       181.28
                Insert CCMX08T308-E07 T25M
2   1328.64   Holder R395.19-3232.4-14           0.96   0.49   3.78       181.28
                Insert CCMX08T308T-M08 T25M
3   -333.83   Holder R395.19-3232.4-14           1.18   0.63   3.48       143.29
                Insert CCMX08T308-E07 S25M
4   -344.54   Holder R395.19-3232.4-14           1.18   0.63   3.48       143.29
                Insert CCMX08T308T-M08 S25M
5   -748.38   Holder R395.19-3232.4-14           1.25   0.66   4.72       135.00
                Insert CCMX08T308-E07 S60M
6   -759.10   Holder R395.19-3232.4-14           1.25   0.66   4.72       135.00
                Insert CCMX08T308T-M08 S60M
*****

```

Table 8.11: Example 11 results

```

*****
Tool list number   : 8
Component name    : Chapter 8 tests
Operation         : Face 200.0mm wide by 200.0mm long by 1.00mm deep
                   with 10.00µm surface finish
Workpiece material : carbon steels, cast - All sub-groups - 150 HB
Machine           : FLEXIMATIC FM300
Notes             : Face 200.0mm wide by 200.0mm long by 1.00mm deep

Selected tool
*****
Cutter            = R220.13-8250-12C
Insert           = SENN120308T-M12 T25M
Total cost       = £ 0.29
Axial passes     = 1
Axial D.O.C.    = 1.00 mm
Radial passes    = 2
Radial D.O.C.   = 100.00 mm
Cutting velocity = 242.14 m/min
Spindle speed    = 308.31 RPM
Feed per tooth   = 0.50 mm
Av. chip thickness = 0.21 mm
Engagement angle = 1.37 mm
Metal removal rate = 246.36 mm
Power            = 11907.29 W
Tool life        = 26.13 min
Comment         =
Notes:
*****
Tool list
*****
Rank Weight   Tool                               Cost   Time   Tool life   MRR
1    10332.71 Holder R220.13-8250-12C           0.29   0.16   26.13      246.36
      Insert SENN120308T-M12 T25M
2    5512.43  Holder R220.13-8250-12C           0.61   0.31   26.13      127.61
      Insert SEKR1303AFTN-ME13 T25M
3    4687.91  Holder R220.13-0125-15           0.48   0.22   13.72      180.49
      Insert SEKR1604AFTN-ME16 T25M
4    4550.45  Holder R220.13-8250-12C           0.68   0.37   25.59      108.38
      Insert SEKR1303AFTN-ME13 S10M
5    4314.93  Holder R220.13-8160-12           0.43   0.24   14.85      165.76
      Insert SENN120308T-M12 T25M
6    4289.04  Holder R220.13-0125-15           0.35   0.25   13.72      158.96
      Insert SENN150408 T25M
7    3961.65  Holder R220.13-8250-12C           0.74   0.40   23.58      99.21
      Insert SEKR1303AFTN-ME13 S25M
8    3630.28  Holder R220.13-0125-15           0.52   0.26   13.54      151.92
      Insert SEKR1604AFTN-ME16 S10M
9    3421.34  Holder R220.13-0100-12           0.46   0.26   13.07      152.07
      Insert SENN120308T-M12 T25M
10   3116.39  Holder R220.13-8160-12           0.53   0.29   14.71      139.71
      Insert SEKR1303AFTN-ME13 S10M
11   2864.65  Holder R220.13-0125-15           0.58   0.29   12.70      135.79
      Insert SEKR1604AFTN-ME16 S25M
12   2396.85  Holder R220.13-8160-12           0.59   0.32   13.91      125.30
      Insert SEKR1303AFTN-ME13 S25M
13   2275.00  Holder R220.13-0100-12           0.56   0.31   12.95      128.14
      Insert SEKR1303AFTN-ME13 S10M
14   1989.47  Holder R220.13-0063-12           0.53   0.31   10.68      128.40
      Insert SENN120308T-M12 T25M
15   1506.49  Holder R220.13-0100-12           0.63   0.35   12.28      114.91
      Insert SEKR1303AFTN-ME13 S25M
16   827.62   Holder R220.13-0063-12           0.65   0.37   10.58      108.15
      Insert SEKR1303AFTN-ME13 S10M
17   87.65    Holder R220.13-0063-12           0.73   0.41   10.01      97.01
      Insert SEKR1303AFTN-ME13 S25M
18   -766.47  Holder R220.13-0100-12           0.88   0.49   15.60      81.63
      Insert SEKN1203AFN-E12 S60M
19   -942.86  Holder R220.13-8160-12           0.96   0.52   17.88      76.64
      Insert SEKN1203AFN-E12 S60M
20   -997.41  Holder R220.13-0040-12           0.76   0.44   6.68       91.93
      Insert SENN120308T-M12 T25M
21   -2223.11 Holder R220.13-0040-12           0.92   0.52   6.63       77.36
      Insert SEKN1203AFTN-M14 S10M
22   -2291.30 Holder R220.13-0040-12           0.93   0.52   7.92       76.92
      Insert SEKN1203AFN-E12 S60M
*****

```

Table 8.12: Example 12 results

```

*****
Tool list number      : 9
Component name       : Chapter 8 tests
Operation            : Face 200.0mm wide by 200.0mm long by 1.00mm deep with 1.00µm
                    : with 1.00µm surface finish
Workpiece material   : carbon steels, cast - All sub-groups - 150 HB
Machine              : FLEXIMATIC FM300
Notes                : Face 200.0mm wide by 200.0mm long by 1.00mm deep

Selected tool
*****
Cutter               = R220.13-8250-12C
Insert               = SEKR1303AFTN-ME13 T25M
Total cost           = £ 0.61
Axial passes         = 1
Axial D.O.C.         = 1.00 mm
Radial passes        = 2
Radial D.O.C.        = 100.00 mm
Cutting velocity     = 286.37 m/min
Spindle speed        = 364.61 RPM
Feed per tooth       = 0.22 mm
Av. chip thickness   = 0.09 mm
Engagement angle     = 1.37 mm
Metal removal rate   = 127.61 mm
Power                = 6168.02 W
Tool life            = 26.13 min
Comment              =
Notes:

*****
Tool list
*****
Rank Weight   Tool                               Cost   Time   Tool life   MRR
1    5958.70   Holder R220.13-8250-12C                 0.61   0.31    26.13    127.61
                Insert SEKR1303AFTN-ME13 T25M
2    5198.85   Holder R220.13-0125-15                   0.48   0.22    13.72    180.49
                Insert SEKR1604AFTN-ME16 T25M
3    4984.57   Holder R220.13-8250-12C                 0.68   0.37    25.59    108.38
                Insert SEKR1303AFTN-ME13 S10M
4    4394.25   Holder R220.13-8250-12C                 0.74   0.40    23.58    99.21
                Insert SEKR1303AFTN-ME13 S25M
5    4286.56   Holder R220.13-8250-12C                 0.73   0.41    26.13    98.44
                Insert SENN120308T-M12 T25M
6    4099.35   Holder R220.13-0125-15                   0.52   0.26    13.54    151.92
                Insert SEKR1604AFTN-ME16 S10M
7    3570.36   Holder R220.13-8160-12                   0.53   0.29    14.71    139.71
                Insert SEKR1303AFTN-ME13 S10M
8    3317.67   Holder R220.13-0125-15                   0.58   0.29    12.70    135.79
                Insert SEKR1604AFTN-ME16 S25M
9    2838.38   Holder R220.13-8160-12                   0.59   0.32    13.91    125.30
                Insert SEKR1303AFTN-ME13 S25M
10   2715.13   Holder R220.13-0100-12                   0.56   0.31    12.95    128.14
                Insert SEKR1303AFTN-ME13 S10M
11   1941.05   Holder R220.13-0100-12                   0.63   0.35    12.28    114.91
                Insert SEKR1303AFTN-ME13 S25M
12   1256.93   Holder R220.13-0063-12                   0.65   0.37    10.58    108.15
                Insert SEKR1303AFTN-ME13 S10M
13   517.18    Holder R220.13-0063-12                   0.73   0.41    10.01    97.01
                Insert SEKR1303AFTN-ME13 S25M
14   -323.54   Holder R220.13-0100-12                   0.88   0.49    15.60    81.63
                Insert SEKN1203AFN-E12 S60M
15   -489.84   Holder R220.13-8160-12                   0.96   0.52    17.88    76.64
                Insert SEKN1203AFN-E12 S60M
16   -995.09   Holder R220.13-8160-12                   1.00   0.56    14.85    71.48
                Insert SENN120308T-M12 T25M
17  -1348.31   Holder R220.13-0125-15                   0.89   0.63    13.72    63.52
                Insert SENN150408 T25M
18  -1774.39   Holder R220.13-0040-12                   0.92   0.52    6.63     77.36
                Insert SEKN1203AFTN-M14 S10M
19  -1809.95   Holder R220.13-0100-12                   1.05   0.60    13.07    66.51
                Insert SENN120308T-M12 T25M
20  -1842.05   Holder R220.13-0040-12                   0.93   0.52    7.92     76.92
                Insert SEKN1203AFN-E12 S60M
21  -3545.56   Holder R220.13-0063-12                   1.23   0.72    10.68    55.57
                Insert SENN120308T-M12 T25M
22  -7234.64   Holder R220.13-0040-12                   1.71   0.98    6.68     40.74
                Insert SENN120308T-M12 T25M
*****

```

Table 8.13: Example 13 results

```

*****
Tool list number   : 10
Component name    : Chapter 8 tests
Operation         : Shoulder 80.00mm wide by 200.0mm long by 5.00mm deep
Workpiece material : carbon steels, cast - All sub-groups - 150 HB
Machine           : FLEXIMATIC FM300
Notes            : Shoulder 80.00mm wide by 200.0mm long by 5.00mm deep

```

```

Selected tool
*****
Cutter            = R220.17-0160
Insert           = TPKN2204PDTR-MD15 T25M
Total cost       = £ 0.83
Axial passes     = 1
Axial D.O.C.    = 5.00 mm
Radial passes    = 1
Radial D.O.C.   = 80.00 mm
Cutting velocity = 382.35 m/min
Spindle speed    = 760.65 RPM
Feed per tooth   = 0.09 mm
Av. chip thickness = 0.06 mm
Engagement angle = 1.57 mm
Metal removal rate = 200.73 mm
Power            = 9702.05 W
Tool life        = 13.21 min
Comment         =
Notes:

```

```

*****
Tool list
*****
Rank Weight Tool Cost Time Tool life MRR
1 3590.06 Holder R220.17-0160 0.83 0.40 13.21 200.73
Insert TPKN2204PDTR-MD15 T25M
2 3130.09 Holder R220.17-0125 0.81 0.40 12.86 200.38
Insert TPKN2204PDTR-MD15 T25M
3 2605.11 Holder R220.17-0160 0.92 0.47 13.02 170.98
Insert TPKN2204PDTR-MD15 S10M
4 2116.09 Holder R220.17-0125 0.91 0.47 12.74 170.63
Insert TPKN2204PDTR-MD15 S10M
5 2072.75 Holder R220.17-0160 1.00 0.50 12.17 158.80
Insert TPKN2204PPR-MD14 S25M
6 1630.59 Holder R220.17-0160 1.07 0.53 16.54 149.63
Insert TPKR2204PDTR-ME13 S60M
7 1563.92 Holder R220.17-0125 0.98 0.51 12.06 158.30
Insert TPKN2204PPR-MD14 S25M
8 1199.95 Holder R220.17-0125 1.04 0.53 15.43 149.93
Insert TPKR2204PDTR-ME13 S60M
9 301.07 Holder R220.69-0040-16 0.96 0.54 8.71 149.12
Insert APKT1604PDR-E12 T25M
10 123.21 Holder R220.17-0100 1.13 0.57 8.17 140.45
Insert TPKN2204PDTR-MD15 T25M
11 -888.50 Holder R220.69-0040-16 1.15 0.63 8.63 126.87
Insert APFT1604PDTR-D15 S10M
12 -930.21 Holder R220.17-0100 1.26 0.67 8.00 119.57
Insert TPKN2204PDTR-MD15 S10M
13 -1285.39 Holder R220.69-0040-16 1.16 0.68 8.18 117.71
Insert APKT1604PDTR-ME14 S25M
14 -1496.13 Holder R220.17-0100 1.35 0.72 7.37 111.23
Insert TPKN2204PPR-MD14 S25M
15 -1689.44 Holder R220.69-0040-16 1.22 0.72 10.40 111.55
Insert APKT1604PDR-E12 S60M
16 -3489.28 Holder R220.17-0063 1.52 0.81 6.35 98.58
Insert TPKN2204PDTR-MD15 S10M
17 -4139.68 Holder R220.17-0063 1.64 0.87 6.01 91.48
Insert TPKN2204PPR-MD14 S25M
18 -4679.79 Holder R220.17-0063 1.75 0.92 7.70 86.63
Insert TPKR2204PDTR-ME13 S60M
19 -5398.65 Holder R215.17-3032.2-16 1.75 0.96 4.24 83.69
Insert TPKR1603PDTR-ME10 T25M
*****

```

Table 8.14: Example 14 results

```

*****
Tool list number      : 11
Component name       : Chapter 8 tests
Operation            : Shoulder 80.00mm wide by 200.0mm long by 5.00mm deep
Workpiece material   : tool steels, wrought - All sub-groups - 320 HB
Machine              : FLEXIMATIC FM300
Notes                : Shoulder 80.00mm wide by 200.0mm long by 5.00mm deep
    
```

```

Selected tool
*****
Cutter               = R220.17-0160
Insert               = TPKN2204PDTR-MD15 T25M
Total cost           = £ 1.02
Axial passes         = 1
Axial D.O.C.         = 5.00 mm
Radial passes        = 1
Radial D.O.C.        = 80.00 mm
Cutting velocity     = 311.85 m/min
Spindle speed        = 620.41 RPM
Feed per tooth       = 0.09 mm
Av. chip thickness   = 0.06 mm
Engagement angle     = 1.57 mm
Metal removal rate   = 163.72 mm
Power                = 11017.23 W
Tool life            = 10.05 min
Comment              =
Notes:
    
```

```

*****
Tool list
*****

```

Rank	Weight	Tool	Cost	Time	Tool life	MRR
1	4172.90	Holder R220.17-0160	1.02	0.49	10.05	163.72
		Insert TPKN2204PDTR-MD15 T25M				
2	3860.55	Holder R220.17-0160	1.03	0.52	12.46	153.88
		Insert TPKN2204PDTR-MD15 S10M				
3	3632.70	Holder R220.17-0125	1.00	0.49	10.32	162.68
		Insert TPKN2204PDTR-MD15 T25M				
4	3632.66	Holder R220.17-0160	1.06	0.53	10.13	150.16
		Insert TPKN2204PPR-MD14 S25M				
5	3331.17	Holder R220.17-0125	1.01	0.52	12.29	153.46
		Insert TPKN2204PDTR-MD15 S10M				
6	3051.39	Holder R220.17-0125	1.05	0.54	10.37	149.22
		Insert TPKN2204PPR-MD14 S25M				
7	2429.08	Holder R220.17-0160	1.28	0.64	14.82	124.79
		Insert TPKR2204PDTR-ME13 S60M				
8	1922.65	Holder R220.17-0125	1.25	0.64	14.15	124.80
		Insert TPKR2204PDTR-ME13 S60M				
9	752.72	Holder R220.69-0040-16	1.18	0.66	7.04	120.98
		Insert APKT1604PDR-E12 T25M				
10	724.28	Holder R220.17-0100	1.38	0.69	5.84	115.21
		Insert TPKN2204PDTR-MD15 T25M				
11	724.28	Holder R220.17-0100	1.38	0.69	5.84	115.21
		Insert TPKN2204PDTR-MD15 T25M				
12	376.35	Holder R220.17-0100	1.40	0.74	7.59	107.74
		Insert TPKN2204PDTR-MD15 S10M				
13	376.35	Holder R220.17-0100	1.40	0.74	7.59	107.74
		Insert TPKN2204PDTR-MD15 S10M				
14	300.25	Holder R220.69-0040-16	1.28	0.70	8.34	114.13
		Insert APFT1604PDTR-D15 S10M				
15	202.23	Holder R220.69-0040-16	1.24	0.72	7.06	111.06
		Insert APKT1604PDTR-ME14 S25M				
16	172.10	Holder R220.17-0100	1.43	0.76	5.91	105.73
		Insert TPKN2204PPR-MD14 S25M				
17	172.10	Holder R220.17-0100	1.43	0.76	5.91	105.73
		Insert TPKN2204PPR-MD14 S25M				
18	-994.33	Holder R220.69-0040-16	1.47	0.86	9.56	92.80
		Insert APKT1604PDR-E12 S60M				
19	-2174.55	Holder R220.17-0063	1.69	0.90	6.12	88.71
		Insert TPKN2204PDTR-MD15 S10M				
20	-2450.43	Holder R220.17-0063	1.75	0.93	5.16	86.44
		Insert TPKN2204PPR-MD14 S25M				
21	-3914.73	Holder R220.17-0063	2.10	1.11	7.05	72.08
		Insert TPKR2204PDTR-ME13 S60M				

```

*****
    
```

Table 8.15: Example 15 results

```

*****
Tool list number   : 12
Component name    : Chapter 8 tests
Operation         : Shoulder 80.00mm wide by 200.0mm long by 5.00mm deep
Workpiece material : free machining alloy steels, wrought - All sub-groups - 320 HB
Machine           : FLEXIMATIC FM300
Notes             : Shoulder 80.00mm wide by 200.0mm long by 5.00mm deep

```

```

Selected tool
*****
Cutter            = R220.17-0160
Insert            = TPKN2204PDTR-MD15 T25M
Total cost        = f 1.21
Axial passes      = 1
Axial D.O.C.     = 5.00 mm
Radial passes     = 1
Radial D.O.C.    = 80.00 mm
Cutting velocity  = 262.86 m/min
Spindle speed     = 522.95 RPM
Feed per tooth    = 0.09 mm
Av. chip thickness = 0.06 mm
Engagement angle  = 1.57 mm
Metal removal rate = 138.00 mm
Power             = 8337.68 W
Tool life         = 7.53 min
Comment          =
Notes:

```

```

*****
Tool list
*****
Rank Weight   Tool                               Cost   Time   Tool life   MRR
1   4470.26   Holder R220.17-0160                    1.21   0.58    7.53       138.00
                Insert TPKN2204PDTR-MD15 T25M
2   3867.40   Holder R220.17-0125                    1.20   0.59    8.17       136.45
                Insert TPKN2204PDTR-MD15 T25M
3   3427.20   Holder R220.17-0160                    1.36   0.69    9.41       116.54
                Insert TPKN2204PDTR-MD15 S10M
4   3328.23   Holder R220.17-0160                    1.38   0.70    7.61       115.01
                Insert TPKN2204PPR-MD14 S25M
5   2877.31   Holder R220.17-0125                    1.34   0.69    9.79       115.66
                Insert TPKN2204PDTR-MD15 S10M
6   2754.52   Holder R220.17-0125                    1.37   0.70    8.25       113.74
                Insert TPKN2204PPR-MD14 S25M
7   2376.35   Holder R220.17-0160                    1.60   0.80   12.53       100.14
                Insert TPKR2204PDTR-ME13 S60M
8   1855.44   Holder R220.17-0125                    1.57   0.80   12.34        99.88
                Insert TPKR2204PDTR-ME13 S60M
9   1066.51   Holder R220.17-0100                    1.63   0.82    4.11       97.78
                Insert TPKN2204PDTR-MD15 T25M
10  1066.51   Holder R220.17-0100                    1.63   0.82    4.11       97.78
                Insert TPKN2204PDTR-MD15 T25M
11  1011.89   Holder R220.69-0040-16                 1.41   0.79    5.61       101.48
                Insert APKT1604PDR-E12 T25M
12  -16.18    Holder R220.17-0100                    1.84   0.97    5.38       82.11
                Insert TPKN2204PDTR-MD15 S10M
13  -16.18    Holder R220.17-0100                    1.84   0.97    5.38       82.11
                Insert TPKN2204PDTR-MD15 S10M
14  -76.84    Holder R220.17-0100                    1.85   0.98    4.16       81.42
                Insert TPKN2204PPR-MD14 S25M
15  -76.84    Holder R220.17-0100                    1.85   0.98    4.16       81.42
                Insert TPKN2204PPR-MD14 S25M
16  -147.91   Holder R220.69-0040-16                 1.62   0.95    5.67       84.55
                Insert APKT1604PDTR-ME14 S25M
17  -165.58   Holder R220.69-0040-16                 1.70   0.93    6.69       86.00
                Insert APFT1604PDTR-D15 S10M
18  -1055.14  Holder R220.69-0040-16                 1.84   1.08    8.37       74.29
                Insert APKT1604PDR-E12 S60M
19  -2706.29  Holder R220.17-0063                    2.25   1.20    4.87       66.90
                Insert TPKN2204PDTR-MD15 S10M
20  -2843.54  Holder R220.17-0063                    2.29   1.22    4.10       65.81
                Insert TPKN2204PPR-MD14 S25M
21  -3967.00  Holder R220.17-0063                    2.63   1.39    6.15       57.75
                Insert TPKR2204PDTR-ME13 S60M
*****

```

Table 8.16: Example 16 results

```

*****
Tool list number   : 13
Component name    : Chapter 8 tests
Operation         : Shoulder 80.00mm wide by 200.0mm long by 5.00mm deep
Workpiece material : stainless steels, cast - All sub-groups - 290 HB
Machine           : FLEXIMATIC FM300
Notes             : Shoulder 80.00mm wide by 200.0mm long by 5.00mm deep

```

Selected tool

```

*****
Cutter            = R220.17-0160
Insert           = TPKN2204PDTR-MD15 T15M
Total cost       = £ 1.23
Axial passes     = 1
Axial D.O.C.    = 5.00 mm
Radial passes    = 1
Radial D.O.C.   = 80.00 mm
Cutting velocity = 261.32 m/min
Spindle speed    = 519.89 RPM
Feed per tooth   = 0.09 mm
Av. chip thickness = 0.06 mm
Engagement angle = 1.57 mm
Metal removal rate = 137.20 mm
Power            = 7117.02 W
Tool life        = 7.77 min
Comment          =
Notes:

```

```

*****
Tool list
*****
Rank Weight   Tool                               Cost   Time   Tool life   MRR
1    6142.03  Holder R220.17-0160                       1.23   0.58    7.77       137.20
                Insert TPKN2204PDTR-MD15 T15M
2    5544.21  Holder R220.17-0125                       1.22   0.59    8.34       135.72
                Insert TPKN2204PDTR-MD15 T15M
3    3841.03  Holder R220.17-0160                       1.71   0.82    7.48       97.66
                Insert TPKN2204PDTR-MD15 T25M
4    3382.61  Holder R220.17-0160                       1.41   0.91    8.39       87.48
                Insert TPKR2204PDTR-ME13 HX
5    3350.78  Holder R220.17-0160                       1.78   0.90   10.64       88.93
                Insert TPKN2204PPR-MD14 S25M
6    3243.10  Holder R220.17-0125                       1.70   0.83    8.13       96.55
                Insert TPKN2204PDTR-MD15 T25M
7    2809.16  Holder R220.17-0125                       1.75   0.90   10.82       88.44
                Insert TPKN2204PPR-MD14 S25M
8    2719.26  Holder R220.17-0100                       1.66   0.82    4.29       97.32
                Insert TPKN2204PDTR-MD15 T15M
9    421.45   Holder R220.17-0100                       2.30   1.16    4.08       69.20
                Insert TPKN2204PDTR-MD15 T25M
10   421.45   Holder R220.17-0100                       2.30   1.16    4.08       69.20
                Insert TPKN2204PDTR-MD15 T25M
11   394.81   Holder R220.69-0040-16                     2.00   1.11    5.58       71.80
                Insert APKT1604PDR-E12 T25M
12   204.73   Holder R220.17-0063                       2.04   1.01    4.15       78.82
                Insert TPKN2204PDTR-MD15 T15M
13  -104.27   Holder R220.69-0040-16                     2.08   1.22    7.37       65.76
                Insert APKT1604PDTR-ME14 S25M
14  -136.54   Holder R220.17-0100                       2.41   1.28    6.26       62.47
                Insert TPKN2204PPR-MD14 S25M
15  -136.54   Holder R220.17-0100                       2.41   1.28    6.26       62.47
                Insert TPKN2204PPR-MD14 S25M
16  -448.26   Holder R220.69-0040-16                     2.18   1.24    6.02       64.73
                Insert APKT1604PDR-E12 HX
17  -484.70   Holder R220.17-0100                       2.51   1.29    4.76       62.15
                Insert TPKN2204PPR-M14 HX
18  -2771.32  Holder R220.17-0063                       2.93   1.56    5.38       51.13
                Insert TPKN2204PPR-MD14 S25M
19  -3116.97  Holder R220.17-0063                       3.08   1.58    4.38       50.58
                Insert TPKN2204PPR-M14 HX
*****

```

Table 8.17: Example 17 results

Data source	v (m/min)	s_z (mm)	m (cm ³ /min)	Power (W)	Cost (£)
Seco handbook	295	0.10	81	-	-
Seco handbook	240	0.20	132	-	-
Seco handbook	210	0.30	173	-	-
MILDA (30 min tool life)	266	0.15	110	4000	-
MILDA (30 min tool life)	241	0.21	142	5000	-
MILDA (30 min tool life)	222	0.28	170	6000	-
MILDA (30 min tool life)	207	0.34	195	7000	-
Machinability assessor (200Bhn)	238	0.19	124	-	-
Machinability assessor (250Bhn)	219	0.18	108	-	-
Machinability assessor (300Bhn)	221	0.14	85	-	-
Max. Prod. Rate (0% harshness)	285.17	0.15	117.72	5690	2.62
Max. Prod. Rate (50% harshness)	245.95	0.31	210.30	10165	1.47
Max. Prod. Rate (100% harshness)	225.97	0.48	293.17	14170	1.05
Min. Prod. Cost (0% harshness)	219.35	0.15	90.55	4376	2.26
Min. Prod. Cost (50% harshness)	189.18	0.31	161.77	7819	1.26
Min. Prod. Cost (100% harshness)	173.82	0.48	225.50	10899	0.91
8 min Tool Life (0% harshness)	382.04	0.15	157.70	7622	4.65
16 min Tool Life (0% harshness)	328.78	0.15	135.72	6560	3.29
32 min Tool Life (0% harshness)	282.94	0.15	116.80	5654	2.60
65 min Tool Life (0% harshness)	243.50	0.15	100.51	4858	2.30
130 min Tool Life (0% harshness)	209.55	0.15	86.50	4180	2.26
195 min Tool Life (0% harshness)	191.93	0.15	79.23	3829	2.32

Table 8.18: Example 18 results

Data source	v (m/min)	s_z (mm)	m (cm ³ /min)	Power (W)	Cost (£)
Seco handbook	275	0.10	72	-	-
Seco handbook	245	0.15	96	-	-
MILDA (30 min tool life)	308	0.10	81	4000	-
MILDA (30 min tool life)	295	0.11	85	4000	-
MILDA (30 min tool life)	285	0.13	97	4000	-
MILDA (30 min tool life)	275	0.15	108	4000	-
MILDA (30 min tool life)	259	0.18	122	5000	-
MILDA (30 min tool life)	246	0.22	142	5000	-
Machinability assessor (100Bhn)	144	0.18	68	-	-
Machinability assessor (150Bhn)	128	0.18	60	-	-
Machinability assessor (200Bhn)	111	0.18	52	-	-
Machinability assessor (250Bhn)	95	0.15	37	-	-
Machinability assessor (300Bhn)	79	0.09	19	-	-
Max. Prod. Rate (0% harshness)	429.59	0.10	112.35	5430	0.27
Max. Prod. Rate (50% harshness)	373.16	0.21	195.19	9434	0.16
Max. Prod. Rate (100% harshness)	343.64	0.31	269.63	13032	0.11
Min. Prod. Cost (0% harshness)	331.12	0.10	86.60	4186	0.24
Min. Prod. Cost (50% harshness)	287.62	0.21	150.45	7272	0.14
Min. Prod. Cost (100% harshness)	264.88	0.31	207.83	10045	0.10
8 min Tool Life (0% harshness)	430.02	0.10	112.46	5436	0.27
16 min Tool Life (0% harshness)	370.07	0.10	96.78	4678	0.24
32 min Tool Life (0% harshness)	319.45	0.10	83.54	4038	0.24
65 min Tool Life (0% harshness)	274.91	0.10	71.90	3475	0.25

Table 8.19: Example 19 results

8.3 Tool variety reduction example

The tool variety reduction method of OPTIMUM may be demonstrated by applying it to several of the operations given in the previous section. Three suitable operations are described in examples 5, 7 and 14. To recap, these operations are:

Machine	FLEXIMATIC FM300
Material	Carbon steel, cast - 150 HB
Example 5	Slot 44.00mm wide by 200.0mm long by 9.00mm deep
Example 7	Pocket 50.00mm wide by 200.0mm long by 5.00mm deep with 15.0mm corner radius
Example 14	Shoulder 80.00mm wide by 200.0mm long by 5.00mm deep

Table 8.20: Sample operations for tool variety reduction

These examples are for operation types that can be machined by a variety of cutter types such as face cutters, square shoulder cutters, slotting cutters and end mills. Thus, it is likely that some tools will be capable of machining more than one of these operations. The tool lists presented in the previous section contain 8, 6 and 19 tools respectively. Thus the number of possible tool sets is $8 \times 6 \times 19 = 912$. The example tool variety reduction procedure is initiated as shown in Figure 8.6.

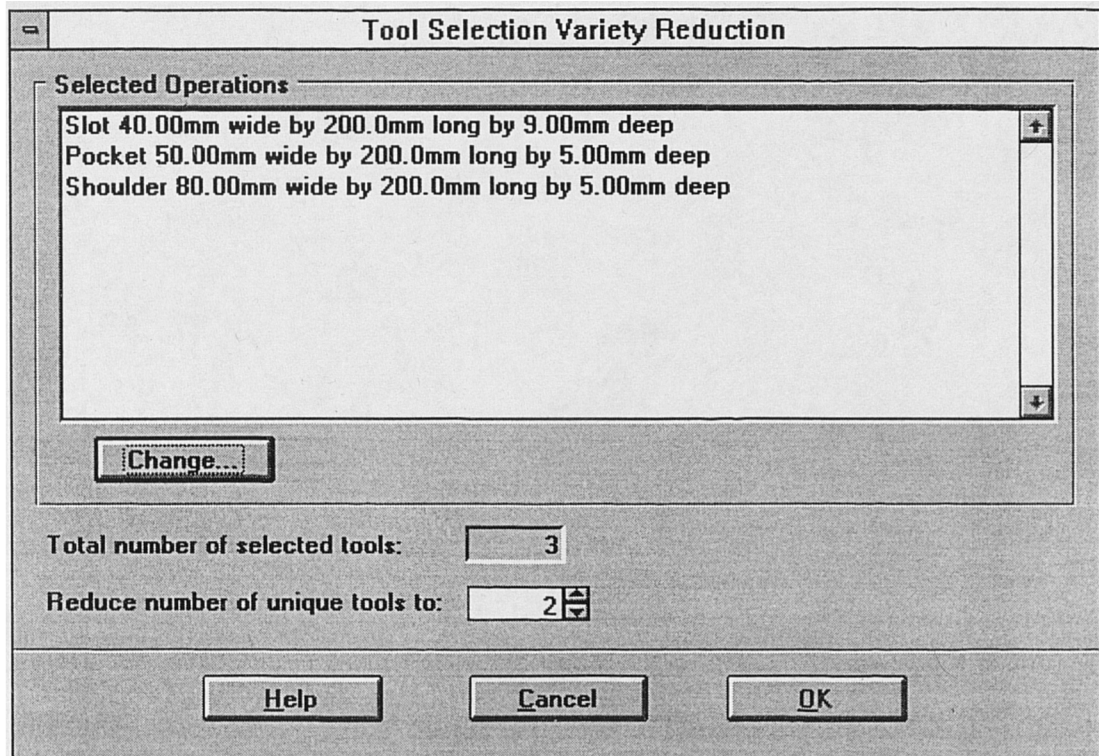

Figure 8.6: Tool variety reduction example setup

Reducing the number of unique tools to just two gives 88 possible tool sets from the 912 possible sets in 17 seconds on a 33MHz 486 based PC. The results are presented in the form shown in Figure 8.7.

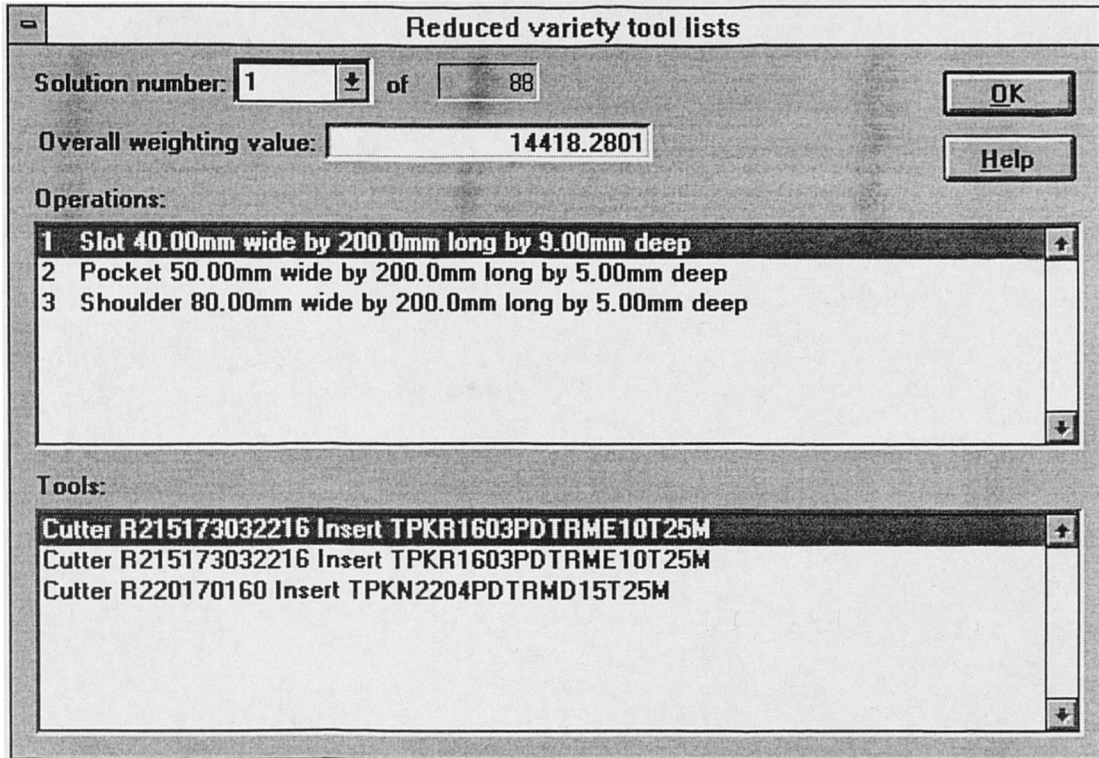

Figure 8.7: Tool variety reduction example results

The full list of possible tool sets is given in Table 8.21.

Rank	Weight	Example 5 (Slot milling)	Example 7 (Pocket milling)	Example 14 (Face milling)
1	14418.28	R215.17-3032.2-16 TPKR1603PDTR-ME10 T25M	R215.17-3032.2-16 TPKR1603PDTR-ME10 T25M	R220.17-0160 TPKN2204PDTR-MD15 T25M
2	13958.31	R215.17-3032.2-16 TPKR1603PDTR-ME10 T25M	R215.17-3032.2-16 TPKR1603PDTR-ME10 T25M	R220.17-0125 TPKN2204PDTR-MD15 T25M
3	13433.33	R215.17-3032.2-16 TPKR1603PDTR-ME10 T25M	R215.17-3032.2-16 TPKR1603PDTR-ME10 T25M	R220.17-0160 TPKN2204PDTR-MD15 S10M
4	12944.32	R215.17-3032.2-16 TPKR1603PDTR-ME10 T25M	R215.17-3032.2-16 TPKR1603PDTR-ME10 T25M	R220.17-0125 TPKN2204PDTR-MD15 S10M
5	12900.97	R215.17-3032.2-16 TPKR1603PDTR-ME10 T25M	R215.17-3032.2-16 TPKR1603PDTR-ME10 T25M	R220.17-0160 TPKN2204PPR-MD14 S25M
6	12458.82	R215.17-3032.2-16 TPKR1603PDTR-ME10 T25M	R215.17-3032.2-16 TPKR1603PDTR-ME10 T25M	R220.17-0160 TPKR2204PDTR-ME13 S60M
7	12392.14	R215.17-3032.2-16 TPKR1603PDTR-ME10 T25M	R215.17-3032.2-16 TPKR1603PDTR-ME10 T25M	R220.17-0125 TPKN2204PPR-MD14 S25M
8	12028.17	R215.17-3032.2-16 TPKR1603PDTR-ME10 T25M	R215.17-3032.2-16 TPKR1603PDTR-ME10 T25M	R220.17-0125 TPKR2204PDTR-ME13 S60M
9	11928.92	R215.17-3032.2-16 TPKN1603PDTR-MD12 S10M	R215.17-3032.2-16 TPKN1603PDTR-MD12 S10M	R220.17-0160 TPKN2204PDTR-MD15 T25M
10	11468.95	R215.17-3032.2-16 TPKN1603PDTR-MD12 S10M	R215.17-3032.2-16 TPKN1603PDTR-MD12 S10M	R220.17-0125 TPKN2204PDTR-MD15 T25M
11	11129.29	R215.17-3032.2-16 TPKR1603PDTR-ME10 T25M	R215.17-3032.2-16 TPKR1603PDTR-ME10 T25M	R220.69-0040-16 APKT1604PDR-E12 T25M
12	11118.25	R215.17-3032.2-16	R215.17-3032.2-16	R220.17-0160

Rank	Weight	Example 5 (Slot milling)	Example 7 (Pocket milling)	Example 14 (Face milling)
		TPGN160308 S25M	TPGN160308 S25M	TPKN2204PDTR-MD15 T25M
13	10951.44	R215.17-3032.2-16 TPKR1603PDTR-ME10 T25M	R215.17-3032.2-16 TPKR1603PDTR-ME10 T25M	R220.17-0100 TPKN2204PDTR-MD15 T25M
14	10943.97	R215.17-3032.2-16 TPKN1603PDTR-MD12 S10M	R215.17-3032.2-16 TPKN1603PDTR-MD12 S10M	R220.17-0160 TPKN2204PDTR-MD15 S10M
15	10658.28	R215.17-3032.2-16 TPGN160308 S25M	R215.17-3032.2-16 TPGN160308 S25M	R220.17-0125 TPKN2204PDTR-MD15 T25M
16	10454.95	R215.17-3032.2-16 TPKN1603PDTR-MD12 S10M	R215.17-3032.2-16 TPKN1603PDTR-MD12 S10M	R220.17-0125 TPKN2204PDTR-MD15 S10M
17	10411.61	R215.17-3032.2-16 TPKN1603PDTR-MD12 S10M	R215.17-3032.2-16 TPKN1603PDTR-MD12 S10M	R220.17-0160 TPKN2204PPR-MD14 S25M
18	10133.30	R215.17-3032.2-16 TPGN160308 S25M	R215.17-3032.2-16 TPGN160308 S25M	R220.17-0160 TPKN2204PDTR-MD15 S10M
19	9969.45	R215.17-3032.2-16 TPKN1603PDTR-MD12 S10M	R215.17-3032.2-16 TPKN1603PDTR-MD12 S10M	R220.17-0160 TPKR2204PDTR-ME13 S60M
20	9939.72	R215.17-3032.2-16 TPKR1603PDTR-ME10 T25M	R215.17-3032.2-16 TPKR1603PDTR-ME10 T25M	R220.69-0040-16 APFT1604PDTR-D15 S10M
21	9902.78	R215.17-3032.2-16 TPKN1603PDTR-MD12 S10M	R215.17-3032.2-16 TPKN1603PDTR-MD12 S10M	R220.17-0125 TPKN2204PPR-MD14 S25M
22	9898.01	R215.17-3032.2-16 TPKR1603PDTR-ME10 T25M	R215.17-3032.2-16 TPKR1603PDTR-ME10 T25M	R220.17-0100 TPKN2204PDTR-MD15 S10M
23	9644.28	R215.17-3032.2-16 TPGN160308 S25M	R215.17-3032.2-16 TPGN160308 S25M	R220.17-0125 TPKN2204PDTR-MD15 S10M
24	9600.94	R215.17-3032.2-16 TPGN160308 S25M	R215.17-3032.2-16 TPGN160308 S25M	R220.17-0160 TPKN2204PPR-MD14 S25M
25	9542.84	R215.17-3032.2-16 TPKR1603PDTR-ME10 T25M	R215.17-3032.2-16 TPKR1603PDTR-ME10 T25M	R220.69-0040-16 APKT1604PDTR-ME14 S25M
26	9538.81	R215.17-3032.2-16 TPKN1603PDTR-MD12 S10M	R215.17-3032.2-16 TPKN1603PDTR-MD12 S10M	R220.17-0125 TPKR2204PDTR-ME13 S60M
27	9332.09	R215.17-3032.2-16 TPKR1603PDTR-ME10 T25M	R215.17-3032.2-16 TPKR1603PDTR-ME10 T25M	R220.17-0100 TPKN2204PPR-MD14 S25M
28	9158.79	R215.17-3032.2-16 TPGN160308 S25M	R215.17-3032.2-16 TPGN160308 S25M	R220.17-0160 TPKR2204PDTR-ME13 S60M
29	9138.79	R215.17-3032.2-16 TPKR1603PDTR-ME10 T25M	R215.17-3032.2-16 TPKR1603PDTR-ME10 T25M	R220.69-0040-16 APKT1604PDR-E12 S60M
30	9092.11	R215.17-3032.2-16 TPGN160308 S25M	R215.17-3032.2-16 TPGN160308 S25M	R220.17-0125 TPKN2204PPR-MD14 S25M
31	8873.88	R217.69-03040-13 XCMX13T330TR-M11 S25M	R215.17-3032.2-16 TPKR1603PDTR-ME10 T25M	R215.17-3032.2-16 TPKR1603PDTR-ME10 T25M
32	8728.14	R215.17-3032.2-16 TPGN160308 S25M	R215.17-3032.2-16 TPGN160308 S25M	R220.17-0125 TPKR2204PDTR-ME13 S60M
33	8639.92	R215.17-3032.2-16 TPKN1603PDTR-MD12 S10M	R215.17-3032.2-16 TPKN1603PDTR-MD12 S10M	R220.69-0040-16 APKT1604PDR-E12 T25M
34	8462.07	R215.17-3032.2-16 TPKN1603PDTR-MD12 S10M	R215.17-3032.2-16 TPKN1603PDTR-MD12 S10M	R220.17-0100 TPKN2204PDTR-MD15 T25M
35	8069.00	R217.69-03040-13 XCMX13T308TR-M11 S60M	R215.17-3032.2-16 TPKR1603PDTR-ME10 T25M	R215.17-3032.2-16 TPKR1603PDTR-ME10 T25M
36	7829.26	R215.17-3032.2-16 TPGN160308 S25M	R215.17-3032.2-16 TPGN160308 S25M	R220.69-0040-16 APKT1604PDR-E12 T25M
37	7651.40	R215.17-3032.2-16 TPGN160308 S25M	R215.17-3032.2-16 TPGN160308 S25M	R220.17-0100 TPKN2204PDTR-MD15 T25M
38	7450.36	R215.17-3032.2-16 TPKN1603PDTR-MD12 S10M	R215.17-3032.2-16 TPKN1603PDTR-MD12 S10M	R220.69-0040-16 APFT1604PDTR-D15 S10M
39	7408.65	R215.17-3032.2-16 TPKN1603PDTR-MD12 S10M	R215.17-3032.2-16 TPKN1603PDTR-MD12 S10M	R220.17-0100 TPKN2204PDTR-MD15 S10M
40	7338.95	R215.17-3032.2-16 TPKR1603PDTR-ME10 T25M	R215.17-3032.2-16 TPKR1603PDTR-ME10 T25M	R220.17-0063 TPKN2204PPR-MD15 S10M
41	7053.47	R215.17-3032.2-16 TPKN1603PDTR-MD12 S10M	R215.17-3032.2-16 TPKN1603PDTR-MD12 S10M	R220.69-0040-16 APKT1604PDTR-ME14 S25M
42	6842.73	R215.17-3032.2-16 TPKN1603PDTR-MD12 S10M	R215.17-3032.2-16 TPKN1603PDTR-MD12 S10M	R220.17-0100 TPKN2204PPR-MD14 S25M
43	6688.54	R215.17-3032.2-16 TPKR1603PDTR-ME10 T25M	R215.17-3032.2-16 TPKR1603PDTR-ME10 T25M	R220.17-0063 TPKN2204PPR-MD14 S25M
44	6649.42	R215.17-3032.2-16 TPKN1603PDTR-MD12 S10M	R215.17-3032.2-16 TPKN1603PDTR-MD12 S10M	R220.69-0040-16 APKT1604PDR-E12 S60M
45	6639.69	R215.17-3032.2-16 TPGN160308 S25M	R215.17-3032.2-16 TPGN160308 S25M	R220.69-0040-16 APFT1604PDTR-D15 S10M
46	6597.98	R215.17-3032.2-16 TPGN160308 S25M	R215.17-3032.2-16 TPGN160308 S25M	R220.17-0100 TPKN2204PDTR-MD15 S10M
47	6377.94	R215.17-3025.2-11 TPGN110208 S25M	R215.17-3025.2-11 TPGN110208 S25M	R220.17-0160 TPKN2204PDTR-MD15 T25M

Rank	Weight	Example 5 (Slot milling)	Example 7 (Pocket milling)	Example 14 (Face milling)
48	6242.80	R215.17-3032.2-16 TPGN160308 S25M	R215.17-3032.2-16 TPGN160308 S25M	R220.69-0040-16 APKT1604PDTR-ME14 S25M
49	6148.43	R215.17-3032.2-16 TPKR1603PDTR-ME10 T25M	R215.17-3032.2-16 TPKR1603PDTR-ME10 T25M	R220.17-0063 TPKR2204PDTR-ME13 S60M
50	6032.06	R215.17-3032.2-16 TPGN160308 S25M	R215.17-3032.2-16 TPGN160308 S25M	R220.17-0100 TPKN2204PPR-MD14 S25M
51	5917.97	R215.17-3025.2-11 TPGN110208 S25M	R215.17-3025.2-11 TPGN110208 S25M	R220.17-0125 TPKN2204PDTR-MD15 T25M
52	5838.75	R215.17-3032.2-16 TPGN160308 S25M	R215.17-3032.2-16 TPGN160308 S25M	R220.69-0040-16 APKT1604PDR-E12 S60M
53	5429.57	R215.17-3032.2-16 TPKR1603PDTR-ME10 T25M	R215.17-3032.2-16 TPKR1603PDTR-ME10 T25M	R215.17-3032.2-16 TPKR1603PDTR-ME10 T25M
54	5392.99	R215.17-3025.2-11 TPGN110208 S25M	R215.17-3025.2-11 TPGN110208 S25M	R220.17-0160 TPKN2204PDTR-MD15 S10M
55	5063.75	R215.17-3032.2-16 TPKR1603PDTR-ME10 T25M	R215.17-3032.2-16 TPAN1603PPTN T25M	R215.17-3032.2-16 TPKR1603PDTR-ME10 T25M
56	4903.98	R215.17-3025.2-11 TPGN110208 S25M	R215.17-3025.2-11 TPGN110208 S25M	R220.17-0125 TPKN2204PDTR-MD15 S10M
57	4860.63	R215.17-3025.2-11 TPGN110208 S25M	R215.17-3025.2-11 TPGN110208 S25M	R220.17-0160 TPKN2204PPR-MD14 S25M
58	4849.58	R215.17-3032.2-16 TPKN1603PDTR-MD12 S10M	R215.17-3032.2-16 TPKN1603PDTR-MD12 S10M	R220.17-0063 TPKN2204PDTR-MD15 S10M
59	4464.82	R215.17-3032.2-16 TPKR1603PDTR-ME10 T25M	R215.17-3032.2-16 TPKN1603PDTR-MD12 S10M	R215.17-3032.2-16 TPKR1603PDTR-ME10 T25M
60	4418.48	R215.17-3025.2-11 TPGN110208 S25M	R215.17-3025.2-11 TPGN110208 S25M	R220.17-0160 TPKR2204PDTR-ME13 S60M
61	4351.80	R215.17-3025.2-11 TPGN110208 S25M	R215.17-3025.2-11 TPGN110208 S25M	R220.17-0125 TPKN2204PPR-MD14 S25M
62	4263.43	R215.17-3032.2-16 TPKR1603PDTR-ME10 T25M	R215.17-3032.2-16 TPGN160308 S25M	R215.17-3032.2-16 TPKR1603PDTR-ME10 T25M
63	4199.18	R215.17-3032.2-16 TPKN1603PDTR-MD12 S10M	R215.17-3032.2-16 TPKN1603PDTR-MD12 S10M	R220.17-0063 TPKN2204PPR-MD14 S25M
64	4038.91	R215.17-3032.2-16 TPGN160308 S25M	R215.17-3032.2-16 TPGN160308 S25M	R220.17-0063 TPKN2204PDTR-MD15 S10M
65	3987.83	R215.17-3025.2-11 TPGN110208 S25M	R215.17-3025.2-11 TPGN110208 S25M	R220.17-0125 TPKR2204PDTR-ME13 S60M
66	3915.66	R215.17-3032.2-16 TPKR1603PDTR-ME10 T25M	R215.17-3032.2-16 TPKR1603PDTR-ME10 S25M	R215.17-3032.2-16 TPKR1603PDTR-ME10 T25M
67	3904.96	R215.17-3032.2-16 TPKN1603PDTR-MD12 S10M	R215.17-3032.2-16 TPKR1603PDTR-ME10 T25M	R215.17-3032.2-16 TPKR1603PDTR-ME10 T25M
68	3659.07	R215.17-3032.2-16 TPKN1603PDTR-MD12 S10M	R215.17-3032.2-16 TPKN1603PDTR-MD12 S10M	R220.17-0063 TPKR2204PDTR-ME13 S60M
69	3388.51	R215.17-3032.2-16 TPGN160308 S25M	R215.17-3032.2-16 TPGN160308 S25M	R220.17-0063 TPKN2204PPR-MD14 S25M
70	3387.63	R217.69-03040-13 XCMX13T330TR-M11 T25M	R215.17-3032.2-16 TPKR1603PDTR-ME10 T25M	R215.17-3032.2-16 TPKR1603PDTR-ME10 T25M
71	3295.68	R215.17-3032.2-16 TPGN160308 S25M	R215.17-3032.2-16 TPKR1603PDTR-ME10 T25M	R215.17-3032.2-16 TPKR1603PDTR-ME10 T25M
72	3088.95	R215.17-3025.2-11 TPGN110208 S25M	R215.17-3025.2-11 TPGN110208 S25M	R220.69-0040-16 APKT1604PDR-E12 T25M
73	2940.21	R215.17-3032.2-16 TPKN1603PDTR-MD12 S10M	R215.17-3032.2-16 TPKN1603PDTR-MD12 S10M	R215.17-3032.2-16 TPKR1603PDTR-ME10 T25M
74	2911.10	R215.17-3025.2-11 TPGN110208 S25M	R215.17-3025.2-11 TPGN110208 S25M	R220.17-0100 TPKN2204PDTR-MD15 T25M
75	2848.40	R215.17-3032.2-16 TPGN160308 S25M	R215.17-3032.2-16 TPGN160308 S25M	R220.17-0063 TPKR2204PDTR-ME13 S60M
76	2753.12	R215.17-3032.2-16 TPKR1603PDTR-ME10 S60M	R215.17-3032.2-16 TPKR1603PDTR-ME10 T25M	R215.17-3032.2-16 TPKR1603PDTR-ME10 T25M
77	2129.54	R215.17-3032.2-16 TPGN160308 S25M	R215.17-3032.2-16 TPGN160308 S25M	R215.17-3032.2-16 TPKR1603PDTR-ME10 T25M
78	1899.38	R215.17-3025.2-11 TPGN110208 S25M	R215.17-3025.2-11 TPGN110208 S25M	R220.69-0040-16 APKT1604PDTR-D15 S10M
79	1870.50	R215.17-3025.2-11 TPGN110208 S25M	R215.17-3032.2-16 TPKR1603PDTR-ME10 T25M	R215.17-3032.2-16 TPKR1603PDTR-ME10 T25M
80	1857.67	R215.17-3025.2-11 TPGN110208 S25M	R215.17-3025.2-11 TPGN110208 S25M	R220.17-0100 TPKN2204PDTR-MD15 S10M
81	1502.50	R215.17-3025.2-11 TPGN110208 S25M	R215.17-3025.2-11 TPGN110208 S25M	R220.69-0040-16 APKT1604PDTR-ME14 S25M
82	1291.75	R215.17-3025.2-11 TPGN110208 S25M	R215.17-3025.2-11 TPGN110208 S25M	R220.17-0100 TPKN2204PPR-MD14 S25M
83	1098.45	R215.17-3025.2-11	R215.17-3025.2-11	R220.69-0040-16

Rank	Weight	Example 5 (Slot milling)	Example 7 (Pocket milling)	Example 14 (Face milling)
		TPGN110208 S25M	TPGN110208 S25M	APKT1604PDR-E12 S60M
84	948.30	R215.17-3032.2-16 TPKR1603PDTR-ME10 T25M	R215.17-3025.2-11 TPGN110208 S25M	R215.17-3032.2-16 TPKR1603PDTR-ME10 T25M
85	-701.39	R215.17-3025.2-11 TPGN110208 S25M	R215.17-3025.2-11 TPGN110208 S25M	R220.17-0063 TPKN2204PDTR-MD15 S10M
86	-1351.80	R215.17-3025.2-11 TPGN110208 S25M	R215.17-3025.2-11 TPGN110208 S25M	R220.17-0063 TPKN2204PPR-MD14 S25M
87	-1891.91	R215.17-3025.2-11 TPGN110208 S25M	R215.17-3025.2-11 TPGN110208 S25M	R220.17-0063 TPKR2204PDTR-ME13 S60M
88	-2610.77	R215.17-3025.2-11 TPGN110208 S25M	R215.17-3025.2-11 TPGN110208 S25M	R215.17-3032.2-16 TPKR1603PDTR-ME10 T25M

Table 8.21: Example tool sets from the tool variety reduction procedure

The preferred rationalized tool set consists of the 1st, 3rd and 1st tools in the respective tool lists. The least favourable tool set (88th in the list) consists of the most suboptimal tools for each of the three tool lists. The exhaustive nature of the tool variety reduction process can produce large lists of possible tool sets. Unlike some other tool rationalization methods, all of the associated cutting data is exactly as produced by the cutting data optimization procedure and no modifications are required as all the possible active constraints have been considered for each operation.

It is interesting to note that there is one tool set that is actually over-rationalized. It is possible to machine all three operations with just one insert/cutter combination. This tool set of one unique tool is given at position 53 in the full list of tool sets. Although it would be possible to eliminate all tool sets with fewer unique tools than specified, the loss in performance produced by the additional tool substitutions will tend to place these tool sets at highly suboptimal positions in the list of tool sets. For this reason, it is unlikely that an over-rationalized tool set will appear as the preferred tool set at the top of the list.

8.4 Conformance assessment example

This section describes a full worked example of the operation of the conformance assessment method implemented in the OPTIMUM system. Unfortunately, as an extensive set of cutting tests in industry was not possible in this research project, the approved data table must be filled with synthetic data in order to demonstrate the principles of cutting data conformance assessment by multiple regression.

The operation considered in this example is that given previously in the tool selection Example 8. To recap, the operation is a facing cut 200.0mm wide by 400.0mm long by 4.00mm deep in cast carbon steel. The selected tool is a R220.13-8250-12C facing cutter fitted with SENN120308-E10 T25M inserts. The optimized cutting data is given in Table 8.8.

A set of approved data is constructed for facing in cast carbon steel with the following suggested and approved cutting parameters:

Operation	Material group	S _v	S _{s_z}	S _{a_r}	S _B	A _v	A _{s_z}	A _{a_r}	A _B
Facing	15	100	0.1	25.5	3	100	0.1	25.5	3
Facing	15	120	0.12	25.5	3	120	0.11	25.5	3
Facing	15	140	0.14	24.5	3	140	0.13	24.5	3
Facing	15	160	0.16	25.5	3	160	0.15	25.5	3
Facing	15	180	0.18	25.5	3	178	0.17	25.5	3
Facing	15	200	0.2	25.5	3.1	183	0.19	25.5	3.1
Facing	15	220	0.22	23.5	3	227	0.21	23.5	3
Facing	15	240	0.24	25.5	3	233	0.24	25.5	3
Facing	15	260	0.26	25.5	3	253	0.25	25.5	3
Facing	15	280	0.28	25.5	3	252	0.27	25.5	3
Facing	15	300	0.3	25.5	3	288	0.29	25.5	3
Facing	15	320	0.32	27	3	305	0.3	27	3
Facing	15	340	0.34	19	4	290	0.32	19	4

Table 8.22: Approved data records for face milling cast carbon steel

where S_x is the initial suggested value of parameter *x* and A_x is the approved value of the same parameter. It may be noted that the values of axial and radial depth of cut have not been modified in the approval process as these parameters are not highly constrained in face milling. Thus, just the cutting velocity and feed per tooth will be adjusted in the conformance assessment process.

A multiple regression analysis on the values of approved cutting velocity and suggested cutting velocity produces a polynomial expression relating the former to the latter. This polynomial is shown as a best fit curve on the graph in Figure 8.8. A modified value of cutting velocity is calculated by substituting the initial given value into this best fit equation, as shown by the arrows in Figure 8.8.

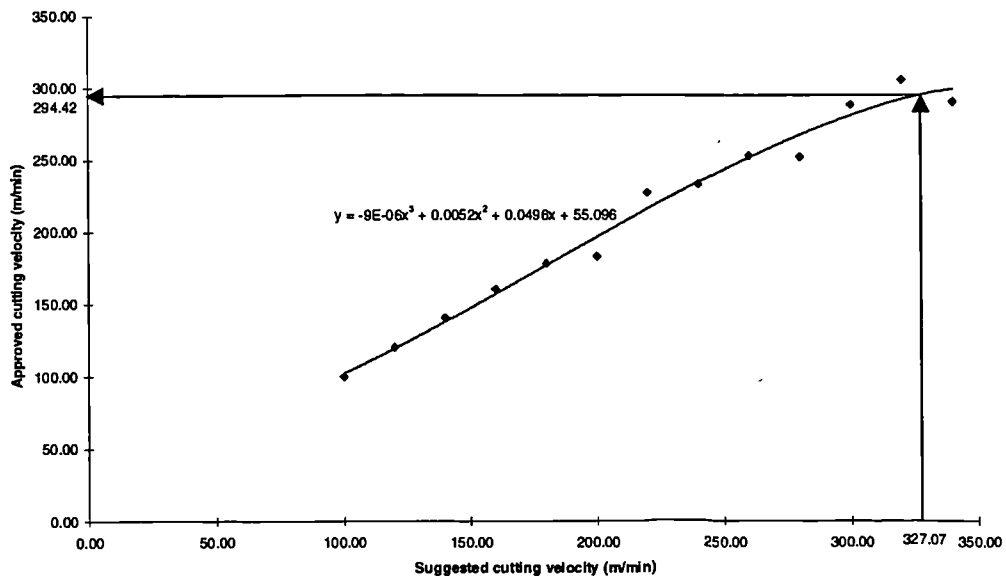

Figure 8.8: Multiple regression curve to interpolate adjusted cutting velocity

Similarly, the value of feed per tooth is modified by applying a polynomial curve fit to the suggested and approved feed per tooth values, as shown in Figure 8.9.

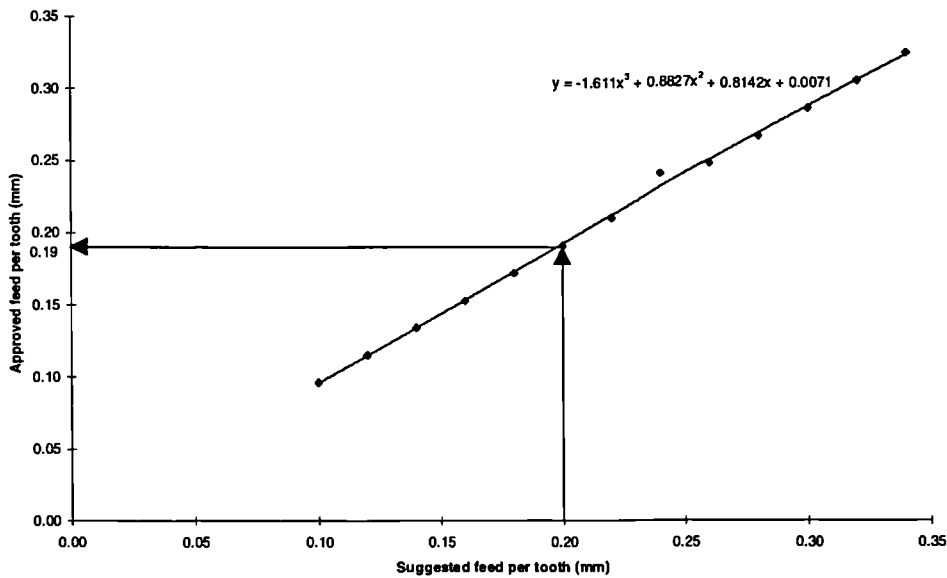

Figure 8.9: Multiple regression curve to interpolate adjusted feed per tooth

The same procedure is applied to axial and radial depth of cut although, in this case, this produces no change to the data as the approved values are the same as the suggested

values in the approved data table. The adjusted cutting data is presented to the user in the dialogue box shown in Figure 8.10.

Conformance Assessment	
Component:	Chapter 8 tests
Operation:	Face 200.0mm wide by 400.0mm long by 4.00mm deep
Material:	carbon steels, cast - All sub-groups - 150 HB
Machine:	FLEXIMATIC FM300
Cutter:	R22013825012C
Insert:	SENN120308E10T25M
Initial data	
Velocity:	327.09 m/min
Feed per tooth:	0.20 mm
Axial depth:	4.00 mm
Radial depth:	66.67 mm
Adjusted data	
Velocity:	294.42 m/min
Feed per tooth:	0.19 mm
Axial depth:	4.00 mm
Radial depth:	66.67 mm
<input type="button" value="OK"/> <input type="button" value="Cancel"/> <input type="button" value="Help"/>	

Figure 8.10: Output of conformance assessment module

As the cutting data optimization routine of OPTIMUM tends to produce aggressive data, approved cutting data is likely to be reduced from the suggested values. This conformance assessment method provides a valuable facility to refine the OPTIMUM system to provide cutting data that is closely tailored to a specific manufacturing environment, including constraints that are not explicitly programmed in the mathematical machining model described in Chapter 4. Further experimental work is required to find an efficient set of approved data matching criteria and to find the most flexible and robust method of modelling the relationship between suggested and approved cutting data.

Chapter 9

Conclusions and recommendations for further work

In research the horizon recedes as we advance, and is no nearer at sixty than it was at twenty. As the power of endurance weakens with age, the urgency of the pursuit grows more intense... And research is always incomplete.

Isaac Casaubon, ch. 10 - Mark Pattison

9.1 Discussion

A system for machinability assessment and automatic tool selection for milling operations called OPTIMUM has been developed. The system has been successfully implemented using FoxPro 2.6 for Windows. Several separate functional modules are integrated together under a uniform graphical user interface. Ease of use has been a major criterion for the software design and this is particularly true of the user interface.

A comprehensive review of published literature was conducted in four main areas: computer aided process planning, cutting data optimization, tool selection and machinability evaluation. Many of the process planning systems reviewed do not include fully featured cutting data optimization or tool selection procedures but allow the user to select the preferred tool and use tables of standard cutting data to provide process parameters. Cutting data optimization for milling is a multivariate problem of greater complexity than for turning, where much research work has centred. A balance needs to be drawn between oversimplifying the mathematical model and including many subtle

constraints that require constants which are usually determined by experimental procedures. There is a dearth of published research about tool selection for milling. Guidelines for desirable performance indicators that can be used for tool selection often tend to contradict advice from other authors. Despite the many published studies of the machining response of individual materials, there has been little work regarding the systematic use of machinability data tables for predicting machinability characteristics for new jobs or material types.

The problem of machinability assessment has been identified. The ongoing reduction in the level of skills and experience of operators and process planners in industry has created an increased requirement for expert support from tool manufacturers. Unfortunately, the accuracy and completeness of the operation data that is often supplied by customers is variable. A method of obtaining initial cutting data with incomplete or imprecise material and operation input data is required. Modern concurrent engineering also demands that process planning calculations be performed very early in the product cycle, when precise component descriptions may not yet be available. In the OPTIMUM system, the mechanical and chemical properties of the workpiece material may be defined in general terms or, if possible, with more specific detail. Similarly, the operation can be defined with a full geometric description or as just a generic type of cut. Rule-based logic has proved to be a robust method for characterizing workpiece material by chemical composition. The system's materials database has been used to automatically induce a set of rules that can reliably categorize a wide variety of materials. Rules possess the advantage that the developer can specify the exact method of evaluating which rules are satisfied by the input data set. Thus, a workpiece material can still be categorized if only a partial chemical composition is given. Combined with multiple regression for enhanced cutting data interpolation, the machinability assessor presents a novel and flexible method for initial cutting parameter determination.

The OPTIMUM system can select tools from a wide range of cutters and inserts for a representative set of common milling operations. By attempting to reject unsuitable tools as early as possible, the process is sufficiently rapid to enable the checking of tens of thousands of possible tools in only a few minutes. Cutters are evaluated against a set of

user defined rules relating suitable cutter rake angles with material types as well as being assessed for geometric compatibility with the operation dimensions. Tool life data has been extracted from manufacturers' handbooks for specific combinations of material group and cutter family. Cutting data may be optimized for maximum production rate, minimum cost or constant tool life. In addition, a new optimization criterion called *harshness* can be defined by the user. The harshness of a cut describes the average chip thickness taken in the cut and is a function of the chip capacity of the cutter. The initial feed per tooth is derived from this harshness value, which can vary from 0% (for conservative cutting data) to 100% (for aggressive cutting data). The optimal tool is selected from a list of feasible tools and associated cutting conditions by a user defined sorting criterion which is a function of maximum metal removal rate, maximum tool life, minimum overall cost and minimum overall time.

The introduction to Chapter 6 presents five levels of tool selection ranging from individual machining operations up to the whole shop floor (multiple machines and multiple workpieces). Many modern machine tools and machining centres feature automated tool changing from a magazine or carousel of preset tools. Thus, for a group of operations on one component, an optimized set of tools is required to fill the limited number of preset tool positions. As the OPTIMUM tool selection module selects tools for individual operations, a process of rationalization is required to produce optimal sets of tools for a group of operations. The tool lists that are created for tool selection purposes are used to reduce the variety of selected tools using pattern matching methods. This method of tool rationalization has the twin benefits of not requiring any recalculation of cutting data and also being totally comprehensive because all the possible combinations of available tools are considered.

The collection and analysis of verified machining data from the shop floor can contribute greatly to overcoming some of the limitations of algorithmic process planning systems. A procedure for the application of approved data to improve the future performance of the system has been described. A set of cutting trials in industry using the aggressive cutting data suggested by the OPTIMUM system was beyond the scope of this research project. This is an area with considerable potential for further work.

9.1.1 Implementation issues

The methods developed in this thesis are of sufficient complexity that verification and validation are only feasible if the algorithm is implemented in software form. The large amount of data that is manipulated during the program execution dictated the use of a programming language that has high level data management functions. As described in Chapter 3, FoxPro 2.6 for Windows was selected and has proved to be a powerful and versatile development tool. However, there are a few points of note regarding the implementation process within the context of the whole research project.

Custom software forms a visible “deliverable” of a research project and it is often judged within the context of commercial software that is widely used within academia and industry. The days of research software with a purely text based interface are, if not gone, at least coming to an end. Of the 48,373 lines of FoxPro code that comprise the OPTIMUM system, a little over half are connected with the user interface. Although certain elements of the user interface design are required to facilitate the efficient use of the program (see Chapter 4), much of this code is concerned with behaviour that is becoming standard within modern Graphical User Interfaces.

It is important that a manufacturing engineering research project should not be dominated by software development but nevertheless, a substantial amount of time is required for language familiarization, control flow specification and interface design. It is to be hoped that the currently growing crop of “*Visual*” programming tools (such as Visual Basic, Delphi and the new version of FoxPro, Visual FoxPro 3.0) will remove some of the onus of interface coding from researchers and allow an approach more focused upon the actual functionality that is required. The end is invariably more important than the means.

9.1.2 Data management and availability

The development process for the OPTIMUM yielded two main ongoing problems: data management and the inevitable debugging phase. The latter is impossible to avoid but the former proved to be surmountable with some considerable effort. Unlike most prototype tool selection systems reported in published literature, the OPTIMUM system works

upon data tables of materials, cutters, inserts etc. which are sufficiently large that data management becomes a significant concern.

All the data that is used in OPTIMUM has been gathered from public domain sources, to avoid the use of parameters that are valuable for complex modelling but esoteric and difficult to obtain. For example, chatter has been handled as an active constraint in some research projects [Enparantza (1991)], but the modal vibration parameters that are required are not generally available and require experimental work for their evaluation. Conversely, many prototype systems do not feature comprehensive coverage of data that is widely available, such as tool catalogues, price lists, workpiece material specifications and machine details. OPTIMUM features a comprehensive tool set and more than seven hundred ferrous workpiece materials.

The data tables used by OPTIMUM are fully normalized and structured in a relational hierarchy. However, much of the data is categorized by three or more independent variables and thus it can become difficult to visualize or navigate as the data would require a three dimensional table structure which is problematic to display on a flat computer monitor. For instance, the example cutting data tables are arranged according to material group, material hardness and depth of cut. As most of these tables contain many hundreds of records, it is often useful to view a subset of the table selected according to a filtering expression. The data management module of OPTIMUM provides user friendly screens to add, edit or delete records from each of the major data tables in the system. In addition, there is a password protected administrator mode that provides a simulated interactive command prompt at which any FoxPro commands may be executed to allow complete freedom in data manipulation.

9.2 Conclusions

The research described in this thesis has addressed the following issues:

- Although there are many centres of excellence for machining, there is a common perception that machining expertise in British industry is declining,

possibly partly due to the ever increasing range of tools and workpiece materials now available.

- Cutting data evaluation and tool selection procedures are performed by tool manufacturers in order to support their customers' tooling requirements as a matter of course.
- Often the operation data supplied by the customer, particularly regarding workpiece material specification, is incomplete.
- Many current process planning systems do not include any capability for automatically selecting cutting tools and optimizing cutting data.
- A consistent method of cutting data generation and tool selection is required.

In order to address these problems:

- A machinability assessment method including rule-based decision logic and statistical interpolation mechanisms was developed to provide feasible initial cutting data for a wide range of operation information, including incomplete or imprecise input data.
- A flexible and robust tool selection and cutting data optimization method has been developed.
- An efficient and exhaustive method of tool variety reduction has been developed to rationalize tool selection for groups of operations, particularly when a only limited number of tools may be used.
- A procedure for the feedback of approved data from the shop floor to improve the conformance and accuracy of the system in the future has been developed.
- The above methods have been implemented on an IBM-compatible PC. The software has been extensively tested with encouraging results.

The research described in this thesis demonstrates novelty in the following ways:

- The application of modern database management technology and mathematical modelling techniques to provide rapid and consistent tool selection for a wide range of tools, materials and optimization criteria. Until recently the

manipulation of such large amounts of data has been hampered by the lack of computer processing power and well structured sources of machining cutting data. Also, compared to turning, there is little published literature regarding computer aided tool selection for milling, probably because the cutting process found in milling is significantly more complex than that for turning.

- The machinability assessor facilitates the generation of initial cutting conditions for a large selection of workpiece materials. Unlike most reported CAPP systems, a wide range of input data is permitted including imprecise material descriptions and incomplete data. *This module has been developed to fulfil a genuine industrial need.*
- Much machining and process planning research is based on small data sets for workpiece materials and tools. This system includes a large materials set (>750 different ferrous alloys) and a comprehensive tool set (the complete catalogue of Seco Tools).
- The system is designed according to the philosophy of data driven operation. All critical parameters including material details, machine and tool information, material categorization rules, and sample cutting data are stored in simple relational database files. Rules and regression calculations may be regenerated in real time so that all calculations will reflect the most recent and appropriate data that is available. It is believed that a high degree of flexibility of operation is necessary for research based CAPP methods to be successfully exploited in the industrial environment.
- As the tool selection method generates comprehensive lists of feasible tools with associated cutting conditions, the system is able to perform tool variety reduction using an exhaustive search on all possible combinations of tools. Cutting data modifications or 'rules of thumb' are not required.
- Most reported machining planning systems are open loop i.e. there is no feedback structure to assist the output of the model to conform more closely with the conditions achieved on the shop floor. However, this research features a feedback interface that presents a simple method of post-processing the suggested data. Combined with the data-driven nature of the software

implementation, the system will produce more accurate data as more recent data is input into the systems data files.

9.3 Recommendations for further work

As this research was partially funded by an industrial sponsoring company, the recommendations for further work are split into two distinct sections. First, the potential for further development and exploitation in an industrial context is discussed. This is followed by a brief exploration of how the basic research behind this project might be extended in the future.

9.3.1 Recommendations for industrial application

Perhaps inevitably, much of the potential further work for industrial application is based upon issues of implementation. The software is fully functional and robust but on-line documentation is missing, although a set of hook routines already exists in the software (every screen or dialogue box has a help button). As the system runs under the Microsoft Windows operating environment, help files can easily be viewed using the standard Windows help engine. Whilst it is hard to justify the considerable effort required to produce comprehensive on-line help during a research project of limited duration, this form of documentation is becoming increasingly *de rigueur* for modern software and it can reduce or even eliminate the requirement for printed manuals.

A study of the likely usage of the system in a given company could be used to streamline the user interface to allow more rapid execution with the most common settings as defaults, without removing any of the user defined options.

A link to the automatic quoting system used at Seco Tools UK would allow the sharing of the most up-to-date lists of available tools and prices. A full data dictionary system would allow even greater sharing of data from a range of sources without the need for extensive recoding or file format translation.

The materials database currently includes only ferrous materials. This could be extended to include major non-ferrous materials such as alloys of aluminium, titanium, nickel, cobalt, tin, etc. Further investigation is required to confirm if these extra material types

exhibit the relationship between physical properties and machining characteristics that has been shown for ferrous alloys. The rule induction system is fed example data directly from the main material data table and the process of refreshing the rule base when the materials table has changed could benefit from a greater degree of automation (currently a small amount of user interaction is required). Ideally, the actual induction engine could be integrated into the OPTIMUM system, thus eliminating any requirement for user interaction.

The tool selection module selects tools and cutting data in a repeatable and highly stable manner. Sometimes a tooling expert will wish to select a tool for reasons of experience or personal preference that are not modelled in the system. As the system is designed to be an advisory tool only, a method for adding extra selection rules or assigning arbitrary weights to tools could be added. An example of an additional rule is *“facing tools are always selected for facing operations, even if a tool of another type, such as a square shoulder cutter or an end mill, would give superior performance”*. This would enable the system to suggest tooling that completely conforms with current company policy and objectives. Whilst these additional rules conflict somewhat with the philosophy of using a complex machining model for tool selection, real commercial objectives may be difficult to express purely in terms of numerical performance indicators and it is believed that flexibility of operation is of primary importance to gain some degree of acceptance in industry.

The conformance assessment interface described in Chapter 7 is at an early stage of development. The method of approved data collection has yet to be determined. A close working relationship with an industrial collaborator would be necessary to be able to attempt aggressive cutting operations in industry. Also the collection of approved data presents some interesting problems in managing the perception of the research project and gaining the trust of workers in the machine shop. This process has recently been attempted for turning operations [Lewis (1995)] with encouraging results.

9.3.2 Recommendations for further research

Some of the proposals for further industrial development described in the preceding section also suggest directions for further academic research. Despite the simplicity of adding additional material types to the materials database, the behaviour of long chipping materials, such as aluminium, requires further investigation. To encourage industrial exploitation, the system should be able to handle the wide range of high performance alloys that are now migrating from aerospace and medical applications to more mainstream industries such as food technology, automotive and general mechanical engineering. The amount of data available regarding these alloys (many of which are proprietary) is small and experimental work may be needed to establish some aspects of the machining response.

OPTIMUM features a straightforward operation geometry input interface. An active link to a CAD system or solid modeller would provide a wealth of extra information to enhance the tool selection process. Feature based CAD technology would enable the extraction of machinable features from a component geometry. Solid modelling software could provide critical information about geometric constraints for complex geometries such as the largest cutter diameter that can fit into a freely contoured pocket. Many CAD/CAM packages feature extensive facilities for tool collision checking and tool path generation. Unfortunately, most of these systems have, at best, rudimentary tool selection and cutting data generation mechanisms. Hence the development of the OPTIMUM system.

The active constraints that are considered by the program could be extended. In particular, constraints that relate to geometry deformation, such as chatter, tool deflection and workpiece deformation, could all benefit from further investigation. It seems likely that a link to a solid modelling system would be required to enable useful analysis of the tool and workpiece deflection problems. However, if workholding is adequate then these can sometimes be reduced to a state that does not actively constrain the cutting parameters. Chatter is an important problem to consider and it may yield to a combination of mathematical modelling of limiting values of process parameters and

effective approved data feedback that will define the actual chatter limits on a given machine setup.

Tool life prediction and management has been a problematic area since before F.W. Taylor proposed his famous equation in 1907. Further experimental work is required to investigate possible extensions to the Taylor equation when applied to milling. Several such additional coefficients are discussed in the literature review, Chapter 2. Tool life scatter is a well known phenomenon and a method of assessing confidence in tool life predictions could be useful for increasing user confidence [Alamin (1996)].

The tool variety reduction algorithm presented here is an efficient and comprehensive method of optimizing tool selection for more than one operation. However, there are several additional functions that could be added to enhance its operation. Full tool wear balancing would require the implementation of sister tooling. Additional interfaces to the cutting data optimization process are needed to allow optimized but highly tailored data to be generated for sister tools and for tools being used with unconventional material/grade combinations. Some modification of the optimized cutting data is also required to enable the formation of tool sets that can machine a given whole number of components i.e. a minimum batch size.

The use of approved data and conformance assessment offers potential advantages of accuracy and robustness over purely algorithmic systems. However, the most promising methods of assessment are still not clear. Much current research deals with nondeterministic modelling methods such as neural nets, genetic algorithms and fuzzy logic. It appears that a combination of the strength of rigorous mathematical modelling with the flexibility of these new modelling techniques offers the best hope to produce industrially applicable CAPP and finally make the difficult leap from laboratory to factory.

References

- Agapiou, J.S. (1992a), 'The optimization of machining operations based on a combined criterion, Part 1: The use of combined objectives in single-pass operations', *Transactions of the ASME, Journal of Engineering for Industry*, vol. **114**, no. 4, 500-507.
- Agapiou, J.S. (1992b), 'The optimization of machining operations based on a combined criterion, Part 2: Multipass operations', *Transactions of the ASME, Journal of Engineering for Industry*, vol. **114**, no. 4, 508-513.
- Aggarwal, T.R. (1985), 'A new approach to selecting machining parameters and machine tools for high speed milling of aluminium', *International Conference*, Detroit, USA, 6-9 May 1985, Technical paper of the SME, Paper MR85-471.
- Alamin, B.B. (1996), 'Tool life prediction and management for an integrated tool selection system', *PhD Thesis*, University of Durham, Durham, UK.
- Alting, L. and Zhang, H.C. (1989), 'Computer-aided process planning - the state-of-the-art survey', *International Journal of Production Research*, vol. **27**, no. 4, 553-585.
- Armarego, E.J.A., Smith, A.J.R. and Wang, J. (1993), 'Constrained optimization strategies and CAM software for single-pass peripheral milling', *International Journal of Production Research*, vol. **31**, no. 9, 2139-2160.
- Arsecularatne, J.A., Hinduja, S. and Barrow, G. (1992), 'Optimum cutting conditions for turned components', *Proceedings of the Institution of Mechanical Engineers part b - Journal of Engineering Manufacture*, vol. **206**, no. 1, 15-31.
- Arsecularatne, J.A. and Mathew, P. (1995), 'An optimal tool replacement strategy for computer numerical controlled turning centres', *Proceedings of the Institution of Mechanical Engineers part b - Journal of Engineering Manufacture*, vol. **209**, no. 6, 481-490.
- Boer, C., De Malherbe, M.C. and Venter, R. (1977), 'Adaptive control optimization for a numerically controlled milling process', *Proceedings 18th MTDR Conference*, Manchester, UK, 665-670.
- Boogert, R.M., Kals, H.J.J. and van Houten, F.J.A.M. (1996), 'Tool paths and cutting technology in computer-aided process planning', *International Journal of Advanced Manufacturing Technology*, vol. **11**, 186-197.
- Boulger, F.W., Moorhead, H.A. and Gavey, T.M. (1951), 'Superior machinability of MX steel explained', *Iron Age*, vol. **167**, 90-95.
- Bouzakis, H.K.D. and Methenitis, G. (1985), 'Determination of the values of the technological parameters which are used to describe the time course of cutting force components in milling.', *Annals of the CIRP*, vol. **34**, no. 1, 141-144.

- Burke, L.I. and Rangwala, S. (1991), 'Tool condition monitoring in metal-cutting - a neural network approach', *Journal of Intelligent Manufacturing*, vol. 2, no. 5, 269-280.
- Carpenter, I.D. and Maropoulos, P.G. (1993), 'A decision support system for process planning milling operations', Bramley, A. and Mileham, T (ed.), *Proceedings 9th National Conference on Manufacturing Research*, Bath University Press, Bath, UK, 22-26.
- Carpenter, I.D. and Maropoulos, P.G. (1994a), 'Milling decisions', *Manufacturing Engineer*, vol. 73, no. 2, 82-83.
- Carpenter, I.D. and Maropoulos, P.G. (1994b), 'A novel machinability assessor for ferrous alloys', Case, K. and Newman, S. (ed.), *Proceedings 10th National Conference on Manufacturing Research*, Francis & Taylor, Loughborough, UK, 632-636.
- Carpenter, I.D. and Maropoulos, P.G. (1995), 'A new method for the flexible definition of machinability for milling operations', *Proceedings 11th International Conference on Computer-Aided Production Engineering*, IMechE Conference Transactions, 55-60.
- Chang, T.C., Anderson, D.C. and Mitchell, O.R. (1988), 'QTC - An integrated design, manufacturing and inspection system for prismatic parts', *Proceedings ASME Computers in Engineering Conference*, San Francisco, California, 417-426.
- Chang, T.C. and Wysk, R.A. (1984), 'Integrating CAD and CAM through automated process planning', *International Journal of Production Research*, vol. 22, no. 5, 877-894.
- Chang, T.C. and Wysk, R.A. (1985), *An Introduction to Process Planning Systems*, Prentice-Hall Inc., Englewood Cliffs, New jersey.
- Chang, T.C., Wysk, R.A., Davis, R.P. and Choi, B. (1982), 'Milling parameter optimization through a discrete variable transformation', *International Journal of Production Research*, vol. 20, no. 4, 507-516.
- Chen, S.J., Hinduja, S. and Barrow, G. (1989), 'Automatic tool selection for rough turning operations', *International Journal of Machine Tools and Manufacture*, vol. 29, no. 4, 535-553.
- Chisholm, A.W.J. and Richardson, B.D. (1965), 'A study of the effect of non-metallic inclusions on the machinability of two ferrous materials', *Proceedings of the Institution of Mechanical Engineers*.
- Czaplicki, L. (1962), 'L'usinabilite et al coupe des metaux', *Res. Soc. Roy. Belge Ingeniere*, vol. 12, 708-736.
- de Jong, M.T. and Fuchs, A. (1994), *PART Advanced Manufacturing Technology White Paper*, ICEM Technologies.

- Domazet, D. (1990), 'The automatic tool selection with the production rules matrix method', *Annals of the CIRP*, vol. 39, no. 1, 497-500.
- Draghici, G. and Paltinea, C. (1974), 'Calculation by convex mathematical programming of the optimum cutting conditions when cylindrical milling', *International Journal of Machine Tool Design and Research*, vol. 14, 143-160.
- Drozda, T.J. and Wick, C. (Ed) (1983), *Tool and Manufacturing Engineers Handbook*, SME, 4th Ed..
- ElMaraghy, H.A., Agerman, E., Davies, B.J., ElMaraghy, W.H. and Eversheim, W. (1993), 'Evolution and future perspectives of CAPP', *Annals of the CIRP*, vol. 42, no. 2, 739-751.
- Enparantza, R. (1991), 'Tool selection and cutting conditions optimisation in milling', *PhD Thesis*, UMIST, Manchester, UK.
- Ermer, D.S. (1971), 'Optimization of the constrained machining economics problem by geometric programming', *Transactions of the ASME, Journal of Engineering for Industry*, vol. 93, 1067-1072.
- Ermer, D.S. and Araj, S.N. (1983), 'Optimum selection of machining conditions for peripheral milling with practical constraints', *Manufacturing Engineering Transactions*, North American Manufacturing Research Institute of SME, Dearborn, Michigan, USA, 453-460.
- Eskicioglu, H. and Davies, B.J. (1983), 'Interactive process planning system for prismatic parts (ICAPP).', *Annals of the CIRP*, vol. 32, no. 1, 365-370.
- Eversheim, W. and Esch, H. (1983), 'Automated generation of process plans for prismatic parts.', *Annals of the CIRP*, vol. 32, no. 1, 361-364.
- Eversheim, W. and Holz, B. (1982), 'Computer aided programming of NC-machine tools by using the system AUTAP-NC', *Annals of the CIRP*, vol. 31, no. 1, 323-327.
- Eversheim, W. and Schulz, J. (1985), 'Survey of computer-aided process planning systems.', *Annals of the CIRP*, vol. 34, no. 2, 607-613.
- Fenton, R.G. and Gagnon, M.F.J. (1993), 'Computer-aided tool material selection for metal-cutting operations', *Annals of the CIRP*, vol. 42, no. 1, 565-568.
- Field, M., Zlatin, N., Williams, R. and Kronenberg, M. (1969), 'Computerized determination and analysis of cost and production rates for machining operations: Part 2 - milling, drilling, reaming, and tapping', *Transactions of the ASME, Journal of Engineering for Industry*, vol. 91, 585-596.
- Friedman, M.Y. and Tipnis, V.A. (1976), 'Cutting rate-tool life characteristic functions for material removal processes Part 1: Theory', *Transactions of the ASME, Journal of Engineering for Industry*, vol. 98, 481-486.

- Friedman, M.Y., Tipnis, V.A. and Field, M. (1975), 'Economic generation of tool life data using the R-T characteristic curve', *Proceedings 16th MTDR Conference*, Manchester, UK, 579-583.
- Gaines, B.R. and Shaw, M.L.G. (1993), 'Eliciting knowledge and transferring it effectively to a knowledge-based system', *IEEE transactions on knowledge and data engineering*, vol. 5, no. 1, 4-14.
- Garret, J.H., Case, M.P., Hall, J.W., Yerramareddy, S., Herman, A., Sun, R., Ranjithan, S. and Westervelt, J. (1993), 'Engineering applications of neural networks', *Journal of Intelligent Manufacturing*, vol. 4, 1-21.
- Gerloch, S.F. (1992), *A methodology for tool selection and rationalisation*, B.Sc. (Hons) Final year project, University of Durham.
- Giusti, F., Santochi, M. and Dini, G. (1986), 'COATS: an expert module for optimal tool selection.', *Annals of the CIRP*, vol. 35, no. 1, 337-340.
- Gouret, J.Y. and Maimi, L. (1986), 'Cutting operations parameters optimization', *Material Science Monographs 35*, Elsevier Science Publishers B.V., Amsterdam, Holland, 215-222.
- Gupta, R., Batra, J.L. and Lal, G.K. (1994), 'Profit rate maximization in multipass turning with constraints: a geometric programming approach', *International Journal of Production Research*, vol. 32, no. 7, 1557-1569.
- Hart, A. (1986), *Knowledge Acquisition for Expert Systems*, Kogan Page, London.
- Henkin, A. and Datsko, J. (1963), 'The influence of physical properties on machinability', *Transactions of the ASME, Journal of Engineering for Industry*, 321-327.
- Hinduja, S. and Barrow, G. (1993), 'SITS - A Semi-Intelligent Tool Selection System for Turned Components', *Annals of the CIRP*, vol. 42, no. 1, 535-539.
- Hinduja, S., Petty, D.J., Tester, M. and Barrow, G. (1985), 'Calculation of optimum cutting conditions for turning operations', *Proceedings of the Institution of Mechanical Engineers part b - Journal of Engineering Manufacture*, vol. 199, no. 2, 81-92.
- Huang, S.H. and Zhang, H.C. (1995), 'Neural-expert hybrid approach for intelligent manufacturing: A survey', *Computers in Industry*, vol. 26, 107-126.
- Intelligent Environments (1992), *Crystal Induction System User Guide*, Intelligent Environments.

- Inui, M., Suzuki, H., Kimura, F. and Sata, T. (1987), 'Extending process planning capabilities with dynamic manipulation of product models', *Proceedings 19th CIRP International Seminar on Manufacturing Systems*, Penn. State, USA, 1-2 June 1987, 273-280.
- Iwata, K. and Fukada, Y. (1987), 'KAPPS: know-how and knowledge assisted production planning system in the machining shop', *Proceedings 19th CIRP International Seminar on Manufacturing Systems*, Penn. State, USA, 1-2 June 1987, 287-292.
- Janitzky, E.J. (1944), 'Machinability of plain carbon, alloy and austenitic steels and its relation to yield stress ratios when tensile strengths are similar', *Transactions of the ASME*, vol. **66**, 649-652.
- Jha, N.K. (1990), 'A discrete-data base multiple objective optimization of milling operation through geometric-programming', *Transactions of the ASME, Journal of Engineering for Industry*, vol. **112**, no. 4, 368-374.
- Jin, L.Z. and Sandstrom, R. (1994a), 'Evaluation of machinability data', *Journal of Testing and Evaluation*, vol. **22**, no. 3, 204-211.
- Jin, L.Z. and Sandstrom, R. (1994b), 'Machinability data applied to materials selection', *Materials and Design*, vol. **16**, no. 6, 339-346.
- Keating, W.G., Lewis, P.R., Simmons, J.E.L. and Maropoulos, P.G. (1995), 'Intelligent tool selection system', *Journal of Materials Processing Technology*, vol. **55**, no. 2, 91-94.
- Kilic, S.E., Cogun, C. and Sen, D.T. (1993), 'A computer-aided graphical technique for the optimization of machining conditions', *Computers in Industry*, vol. **22**, no. 3, 319-326.
- Kiritsis, D. (1995), 'A review of knowledge-based expert systems for process planning. methods and problems', *International Journal of Advanced Manufacturing Technology*, vol. **10**, 240-262.
- Kirksharian, A. and Masory, O. (1988), 'A graphical interactive tool for the solution of the machining economics problem', *Proceedings Computer Engineering Conference*, ASME, 143-148.
- Koenigsberger, F. and Tlustý, J. (1970), *Machine tool structures, volume 1*, Pergamon Press.
- Kohonen, T. (1988), 'An introduction to neural computing', *Neural Networks*, 3-16.
- Kuljanic, E. (1980), 'Random strategy method for determining tool life equations.', *Annals of the CIRP*, vol. **29**, no. 1, 351-356.

- Lau, T.L. (1987), 'Optimization of milling conditions', *PhD Thesis*, UMIST, Manchester, UK.
- Lewis, P.R. (1995), 'Cutting data for automated turning tool selection in industry', *PhD Thesis*, University of Durham, Durham, UK.
- Liy, Y.S. and Allen, R. (1986), 'A proposed synthetic, interactive process planning system', *Proceedings 1st International Conference on Computer Aided Production Engineering*, Edinburgh, Scotland, April 1986, 201-208.
- Luebbe, R. and Finch, B. (1992), 'Theory of constraints and linear programming: a comparison', *International Journal of Production Research*, vol. 30, no. 6, 1471-1478.
- Maropoulos, P.G. (1988), 'Automatic selection of tools for turning operations', *PhD Thesis*, UMIST, Manchester, UK.
- Maropoulos, P.G. (1992), 'Cutting-tool selection - an intelligent methodology and its interfaces with technical and planning functions', *Proceedings of the Institution of Mechanical Engineers part b - Journal of Engineering Manufacture*, vol. 206, no. 1, 49-60.
- Maropoulos, P.G. (1995a), 'Review of research in tooling technology, process modeling and process planning .1. tooling and process modeling', *Computer Integrated Manufacturing Systems*, vol. 8, no. 1, 5-12.
- Maropoulos, P.G. (1995b), 'Review of research in tooling technology, process modeling and process planning .2. process planning', *Computer Integrated Manufacturing Systems*, vol. 8, no. 1, 13-20.
- Maropoulos, P.G. and Alamin, B. (1995), 'Intelligent tool selection for machining cylindrical components Part 2: results from the testing of the knowledge-based module', *Proceedings of the Institution of Mechanical Engineers part b - Journal of Engineering Manufacture*, vol. 209, no. 3, 183-192.
- Maropoulos, P.G. and Gill, P.A.T. (1995), 'Intelligent tool selection for machining cylindrical components Part 1: logic of the knowledge-based module', *Proceedings of the Institution of Mechanical Engineers part b - Journal of Engineering Manufacture*, vol. 209, no. 3, 173-182.
- Maropoulos, P.G. and Hinduja, S. (1989), 'A tool-regulation and balancing system for turning centres', *International Journal of Advanced Manufacturing Technology*, vol. 4, 207-226.
- Maropoulos, P.G. and Hinduja, S. (1990), 'Automatic tool selection for finish turning', *Proceedings of the Institution of Mechanical Engineers part b - Journal of Engineering Manufacture*, vol. 204, no. 1, 43-51.
- Maropoulos, P.G. and Hinduja, S. (1991), 'Automatic tool selection for rough turning', *International Journal of Production Research*, vol. 29, no. 6, 1185-1204.

- Martelotti, M.E. (1945), 'An analysis of the milling process; part II: down milling', *Transactions of the ASME*, vol. 47, 23-251.
- Melkote, R. and Taylor, D.L. (1988), 'Implementation of rule based selection of milling cutters, feed rate and spindle speed', *Proceedings of the Conference on Computers in Engineering*, San Francisco, 1-4 August 1988, ASME, New York, 427-432.
- Metcut Research Associates (1980), *Machining Data Handbook*, Machinability Data Center.
- Metha, N.K. and Singh, C.K. (1980), 'Determination of optimum cutting parameters in face milling operation', *Proceedings 9th AIMTDR Conference IIT*, Kanpur, December 1980, 200-205.
- Milacic, V.R., Urosevic, M., Veljovic, A., Miler, A. and Race, I. (1987), 'SAPT: expert system based on hybrid concept of group technology', *Proceedings 19th CIRP International Seminar on Manufacturing Systems*, Penn. State, USA, 1-2 June 1987, 189-195.
- Mills, B. and Redford, A.H. (1983), *Machinability of Engineering Materials*, Applied Science Publishers.
- Narayanan, V. (1995), 'Systems for the prediction of process parameters', *Journal of Materials Processing Technology*, vol. 54, no. 1-4, 64-69.
- Niebel, B.W. (1965), 'Mechanized process selection for planning new designs', *ASME paper no. 737*.
- Ostafiev, V.A. (1983), 'Integrated optimization of end milling', *Soviet Engineering Research*, vol. 3, no. 7, 32-34.
- Ostafiev, V.A., Globa, A.V. and Globa, L.S. (1984), 'Integrated end milling optimization development.', *Annals of the CIRP*, vol. 33, no. 1, 29-32.
- Park, M.W. and Davies, B.J. (1987), 'Integration of process planning into CAD using IGES', *Proceedings 19th CIRP International Seminar on Manufacturing Systems*, Penn. State, USA, 1-2 June 1987, 315-319.
- Park, M.W., Vosniakos, G.C. and Davies, B.J. (1990), 'Automatic feature extraction in wire frame models of 2+D prismatic parts', *Proceedings 28th MTDR Conference*, 83-89.
- Petropoulos, P.G. (1973), 'Optimal selection of machining rate variables by geometric programming', *International Journal of Production Research*, vol. 11, no. 4, 305-314.
- Quinlan, J.R. (1979), 'Discovering rules by induction from large collections of examples', Michie, D. (ed.), *Expert Systems in the Micro Electronic Age*, Edinburgh University Press, UK, 168-201.

- Radford and Richardson (1980), *Production Engineering Technology*, Macmillan.
- Razfar, R. and Ridgway, K. (1994a), 'Ex-catsmill - an expert system for selecting cutting tools and conditions for milling', *IEE conference publication*, IEE, Stevenage, UK, 203-208.
- Razfar, R. and Ridgway, K. (1994b), 'A knowledge based system for the selection of cutting tools and conditions for milling', Case, K. and Newman, S. (ed.), *Proceedings 10th National Conference on Manufacturing Research*, Francis & Taylor, Loughborough, UK, 259-263.
- Reitz, C. (1981), 'Optimizing milling conditions', *Tooling and Production*, February 1981, 82-84.
- Rembold, U., Nnaji, B.O. and Storr, A. (1993), *Computer integrated manufacturing and engineering*, Addison-Wesley.
- Rho, H.M., Geelink, R., van't Erve, A.H. and Kals, H.J.J. (1992), 'An integrated cutting tool selection and operation sequencing method', *Annals of the CIRP*, vol. 41, no. 1, 517-520.
- Robbins, F.J. and Lawless, J.J. (1955), 'Heat treatment - for better machinability', *Iron Age*, vol. 176, 94-97.
- Sakal, R.L. and Chow, J.G. (1994), 'An integrated intelligent process planning system for prismatic parts using pc-based cad and cam software packages', *International Journal of Advanced Manufacturing Technology*, vol. 9, no. 3, 166-174.
- Salomons, O.W., van Houten, F.J.A.M. and Kals, H.J.J. (1993), 'Review of research in feature-based design', *Journal of Manufacturing Systems*, vol. 12, no. 2, 113-132.
- Sandvik Coromant (1985), *Milling Guide*, Sandvik Coromant, C-1129:005-ENG, Sweden.
- Sandvik Coromant (1991), *Rotating tools and inserts*, Sandvik Tools, C-1100:3-ENG, Sweden.
- Schaeffler, A.L. (1948), 'Welding dissimilar metals with stainless electrodes', *Iron Age*, vol. 162, no. 1, 72-79.
- Schaeffler, A.L. (1949), 'Constitution diagram for stainless steel weld metal', *Metal Progress*, vol. 56, no. 5, 680-680B.
- Seco Tools AB (1993), *Milling Main Catalogue*, Seco Tools, ST934738, Sweden.
- Seco Tools AB (1994), *Milling Technical Guide*, Seco Tools, ST944739E, Sweden.
- Shaw, M.C. (1984), *Metal Cutting Principles*, Oxford University Press.

- Sheikh, A.K., Kendall, L.A. and Pandit, S.M. (1980), 'Probabilistic optimization of multitool machining operations', *Transactions of the ASME, Journal of Engineering for Industry*, vol. **102**, 239-246.
- Shin, Y.C. and Joo, Y.S. (1992), 'Optimization of machining conditions with practical constraints', *International Journal of Production Research*, vol. **30**, no. 12, 2907-2919.
- Smith, S. and Delio, T. (1992), 'Sensor-based chatter detection and avoidance by spindle speed selection', *Transactions of the ASME, Journal of Dynamic Systems Measurement and Control*, vol. **114**, no. 3, 486-492.
- Smith, S. and Tlustý, J. (1991), 'An overview of modeling and simulation of the milling process', *Transactions of the ASME, Journal of Engineering for Industry*, vol. **113**, no. 2, 169-175.
- Sotirov, G.R., Vitanov, V.I., Ghosh, S.K., Mincoff, N.C. and Harrison, D.K. (1992), 'Multicriteria optimization of cutting processes', *Journal of Materials Processing Technology*, vol. **31**, no. 1-2, 307-315.
- Studel, H.J. (1984), 'Computer-aided process planning - past, present and future', *International Journal of Production Research*, vol. **22**, no. 2, 253-266.
- Subrahmanyam, S. and Wozny, M. (1995), 'An overview of automatic feature recognition techniques for computer-aided process planning', *Computers in Industry*, vol. **26**, no. 1, 1-21.
- Tan, F.P. and Creese, R.C. (1995), 'A generalized multi-pass machining model for machining parameter selection in turning', *International Journal of Production Research*, vol. **33**, no. 5, 1467-1487.
- Tansel, I.N., Tziranis, A. and Wagiman, A. (1993a), 'Modeling workpiece vibrations with neural networks', *Journal of Intelligent Manufacturing*, vol. **4**, 95-107.
- Tansel, I.N., Wagiman, A. and Tziranis, A. (1993b), 'Recognition of chatter with neural networks', *International Journal of Machine Tools and Manufacture*, vol. **31**, no. 4, 539-552.
- Tarng, Y.S. and Chen, M.C. (1994), 'An intelligent sensor for detection of milling chatter', *Journal of Intelligent Manufacturing*, vol. **5**, no. 3, 193-200.
- Tarng, Y.S., Hsieh, Y.W. and Hwang, S.T. (1994), 'An intelligent sensor for monitoring milling cutter breakage', *International Journal of Advanced Manufacturing Technology*, vol. **9**, no. 3, 141-146.
- Taylor, F.W. (1907), 'On the art of metal cutting', *Transactions of the ASME*, vol. **28**, 31-350.

- Thompson, W. (1985), 'Computer assisted machining economics', *Automach Australia'85 Conference*, Melbourne, Australia, 2-5 July 1985, Technical paper of the SME, Paper MM85-667.
- Tipnis, V.A. and Friedman, M.Y. (1976), 'Cutting rate-tool life characteristic functions for material removal processes Part 2: Verification and applications', *Transactions of the ASME, Journal of Engineering for Industry*, vol. 98, 487-496.
- Thusty, J. (1978), 'Analysis of the state of research in cutting dynamics', *Annals of the CIRP*, vol. 27, no. 2, 583-589.
- Toh, K.T.K. and Newman, S.T. (1995), 'The future of DNC in batch manufacturing environment', *Proceedings 11th International Conference on Computer-Aided Production Engineering*, IMechE Conference Transactions, 283-287.
- van Houten, F.J.A.M. (1986), 'Strategy in generative planning of turning processes.', *Annals of the CIRP*, vol. 35, no. 1, 331-335.
- van Houten, F.J.A.M. and Kals, H.J.J. (1981), 'Development of a technological processor as a part of a workpiece programming system.', *Annals of the CIRP*, vol. 30, no. 1, 363-368.
- van Houten, F.J.A.M. and van't Erve, A.H. (1988), 'PART, a parallel approach to computer aided process planning', *Proceedings 4th International Conference on Computer-Aided Production Engineering*, Edinburgh, Scotland.
- van Houten, F.J.A.M., van't Erve, A.H., Boogert, R.M., Nauta, J.M. and Kals, H.J.J. (1989), 'PART, a feature based computer aided process planning system', *Proceedings 21st CIRP International Seminar on Manufacturing Systems*, Stockholm, Sweden.
- van Houten, F.J.A.M., van't Erve, A.H., Boogert, R.M., Nauta, J.M. and Kals, H.J.J. (1990), 'PART, selection of machining methods and tools', *Proceedings 22nd CIRP International Seminar on Manufacturing Systems*, Enschede, Holland, June 1990.
- van't Erve, A.H. and Kals, H.J.J. (1986), 'XPLANE, a generative computer aided process planning system for part manufacturing', *Annals of the CIRP*, vol. 35, no. 1, 325-329.
- Wang, J. (1993a), 'A neural-network approach to multiple-objective cutting parameter optimization-based on fuzzy preference information', *Computers and Industrial Engineering*, vol. 25, no. 1-4, 389-392.
- Wang, J. (1993b), 'Multiple-objective optimisation of machining operations based on neural networks', *International Journal of Advanced Manufacturing Technology*, vol. 8, 234-243.
- Weill, R., Spur, G. and Eversheim, W. (1982), 'Survey of computer-aided process planning systems.', *Annals of the CIRP*, vol. 31, no. 2, 539-551.

- Whittman, G.P. (1945), 'Studies of the machinability of carbon and alloy steels', *Mechanical Engineers*, vol. **67**, 575-583.
- Woldman, N.E. (1947), 'Good and bad structures in machining steels', *Material and Methods*, vol. **25**, 80-86.
- Wysk, R.A. (1977), 'An automated process planning and selection program: APPAS', *PhD Thesis*, Purdue University, West Lafayette, Indiana, USA.
- Yellowley, I. and Barrow, G. (1978), 'The assessment of tool life in peripheral milling', *Proceedings 19th MTDR Conference*, 432-452.
- Yellowley, I. and Gunn, E.A. (1989), 'The optimal subdivision of cut in multi-pass machining operations', *International Journal of Production Research*, vol. **27**, no. 9, 1573-1588.
- Yellowley, I., Wong, A. and De Smit, B. (1978), 'The economics of peripheral milling', *Proceedings 6th NAMRC*, 388-394.
- Yeo, S.H., Rahman, M. and Wong, Y.S. (1989), 'Towards enhancement of machinability data by multiple-regression', *Journal of Mechanical Working Technology*, vol. **19**, no. 1, 85-99.
- Yeo, S.H., Wong, Y.S. and Rahman, M. (1991), 'Knowledge-based systems in the machining domain', *International Journal of Advanced Manufacturing Technology*, vol. **6**, 35-44.
- Zhang, J.H. and Hinduja, S. (1995), 'Determination of the optimum tool set for a given batch of turned components', *Annals of the CIRP*, vol. **44**, no. 1, 445-450.
- Zlatin, N. and Field, M. (1950), 'Evaluation of machinability of rolled steels, forgings and cast irons', *Machining Theory and Practice*, A.S.M., Cleveland, Ohio.
- Zompi, A. (1979), 'Tool life distributions in process optimization: Parameter identification and applications', *Annals of the CIRP*, vol. **28**, no. 1, 371-375.
- Zoutendijk, G. (1959), 'Maximizing a function in a convex region', *Journal of the Royal Statistical Society*, vol. **21**, no. 2, 338-355.
- Zoutendijk, G. (1960), *Methods of feasible directions*, Elsevier, Amsterdam.

Appendix A

Data table structures

This Appendix lists the structures of all the major data tables used or created by the OPTIMUM system and includes a short description for each field. This list is based upon a structure dump from FoxPro for Windows. Each field is described by name, type, width and number of decimal places, if any.

Structure for table: approved.dbf

Table description: Approved cutting data table

Number of data records: 13

Field	Name	Type	Width	Decimals	Description
1	OP_ID	Numeric	10		Unique ID number for this record
2	MACH_TYPE	Numeric	4		Machine type
3	MACH_NO	Numeric	4		Machine reference number
4	DATE	Date	8		Date of operation
5	COMP_NO	Numeric	5		Component number
6	OP_NO	Numeric	3		Operation number
7	OPTYPE	Numeric	3		Operation type
8	OP_DESC	Character	60		Description of operation
9	MAT_GROUP	Numeric	6		Material group
10	MACH_GROUP	Numeric	6		Machinability group
11	MAT_DESC	Character	100		Description of material
12	MAT_HARD	Numeric	5		Material surface hardness (BHN)
13	S_V	Numeric	10	2	Suggested cutting velocity (m/min)
14	S_SZ	Numeric	6	2	Suggested feed per tooth (mm)
15	S_HM	Numeric	6	2	Suggested average chip thickness (mm)
16	S_AR	Numeric	10	2	Suggested radial depth of cut (mm)
17	S_AA	Numeric	10	2	Suggested axial depth of cut (mm)
18	S_RPASSES	Numeric	6		Suggested radial passes
19	S_APASSES	Numeric	6		Suggested axial passes
20	S_TL	Numeric	4		Suggested tool life (min)
21	S HOLDER	Numeric	10		Suggested holder reference
22	S_INSERT	Numeric	10		Suggested insert reference
23	S_GRADE	Character	10		Suggested insert grade
24	S_EXT	Character	30		Extra information
25	A_V	Numeric	10	2	Approved cutting velocity (m/min)
26	A_SZ	Numeric	10	4	Approved feed per tooth (mm)
27	A_HM	Numeric	6	2	Approved average chip thickness (mm)
28	A_AR	Numeric	10	2	Approved radial depth of cut (mm)
29	A_AA	Numeric	10	2	Approved axial depth of cut (mm)
30	A_RPASSES	Numeric	6		Approved radial passes
31	A_APASSES	Numeric	6		Approved axial passes
32	A_TL	Numeric	4		Approved tool life (min)
33	A_VIBR	Numeric	6		Approved vibration index
34	A_CHIPS	Numeric	6		Approved chipping index
35	A_PROBS	Character	100		Description of any problems

Structure for table: face_rat.dbf

Table description: Ratios of cutting velocity between common insert grades for facing

Number of data records: 250

Field	Name	Type	Width	Decimals	Description
1	GROUP_NO	Numeric	4		Seco material group
2	STARTGRADE	Character	9		Primary insert grade
3	ENDGRADE	Character	9		Secondary insert grade
4	F_RATIO	Numeric	9	2	Ratio for finishing
5	SR_RATIO	Numeric	9	2	Ratio for semi-roughing
6	R_RATIO	Numeric	9	2	Ratio for roughing

Structure for table: cdmill.dbf

Table description: Table for tool life data

Number of data records: 10976

Field	Name	Type	Width	Decimals	Description
1	MATGRP	Numeric	3		Seco material group
2	DATASET	Character	10		Cutter family code
3	GRADE	Character	6		Insert grade
4	FEED	Numeric	5	2	Feed rate (mm/min)
5	VVAL	Numeric	5		Cutting velocity (m/min)
6	KSVAL	Numeric	5		Specific resistance to cut (N/mm ²)
7	TOOLLIFE	Numeric	3		Tool life (min)
8	LNT	Numeric	20	10	Natural logarithm of tool life
9	LNV	Numeric	20	10	Natural logarithm of cutting velocity
10	LNS	Numeric	20	10	Natural logarithm of feed

Structure for table: comps.dbf

Table description: Component description table

Number of data records: 12

Field	Name	Type	Width	Decimals	Description
1	COMP_NO	Numeric	5		Component reference number
2	OP_NO	Numeric	3		Operation reference number
3	DESCRIPT	Character	80		Description of component
4	OPDESC	Character	60		Description of operation
5	CUTTYPE	Numeric	3		Cut type (roughing, semi-roughing, finishing)
6	OPTYPE	Numeric	3		Operation type code
7	OPDIMEN1	Numeric	8	2	Operation dimension one
8	OPDIMEN2	Numeric	8	2	Operation dimension two
9	OPDIMEN3	Numeric	8	2	Operation dimension three
10	OPDIMEN4	Numeric	8	2	Operation dimension four
11	OPDIMEN5	Numeric	8	2	Operation dimension five
12	OPDIMEN6	Numeric	8	2	Operation dimension six

Structure for table: face_dat.dbf

Table description: Standard cutting data for facing

Number of data records: 804

Field	Name	Type	Width	Decimals	Description
1	MAT_GRP	Numeric	10		Material group
2	MACH_GRP	Numeric	10		Machinability group
3	MIN_HARD	Numeric	6		Minimum surface hardness (BHn)
4	MAX_HARD	Numeric	6		Maximum surface hardness (BHn)
5	CONDIT	Character	18		Surface conditioning
6	DOC	Numeric	3		Depth of cut (mm)
7	HSS_V	Numeric	10		Cutting velocity - HSS tools (m/min)
8	HSS_SZ	Numeric	10	3	Feed per tooth - HSS tools (mm)
9	HSS_TMAT	Character	10		Tool material type - HSS tools
10	UNC_BRAZ	Numeric	10		Cut velocity - brazed uncoated tools (m/min)
11	UNC_INDXX	Numeric	10		Cut velocity - indexed uncoated tools (m/min)
12	UNC_SZ	Numeric	10	3	Feed per tooth - uncoated tools (mm)
13	UNC_TMAT	Character	10		Tool material type - uncoated tools
14	CT_V	Numeric	10		Cutting velocity - coated tools (m/min)
15	CT_SZ	Numeric	10	3	Feed per tooth - coated tools (mm)
16	CT_TMAT	Character	10		Tool material type - coated tools

Structure for table: grades.dbf

Table description: Insert grade details

Number of data records: 13

Field	Name	Type	Width	Decimals	Description
1	GRADE	Character	10		Insert grade
2	TYPE	Numeric	2		General type (coated, uncoated etc)
3	INS_DESC	Memo	10		Description of grade properties
4	P_MIN	Numeric	4		Minimum ISO P value
5	P_MAX	Numeric	4		Maximum ISO P value
6	M_MIN	Numeric	4		Minimum ISO M value
7	M_MAX	Numeric	4		Maximum ISO M value
8	K_MIN	Numeric	4		Minimum ISO K value
9	K_MAX	Numeric	4		Maximum ISO K value
10	MAKER	Character	50		Manufacturer's name

Structure for table: groups.dbf

Table description: Store names and numbers of all machinability groups

Number of data records: 106

Field	Name	Type	Width	Decimals	Description
1	MAT_NO	Numeric	5		Material group
2	MACH_NO	Numeric	5		Machinability group
3	MACH_NAME	Character	50		Machinability group description

Structure for table: machgrps.dbf

Table description: Material classification rules

Number of data records: 182

Field	Name	Type	Width	Decimals	Description
1	GROUP	Numeric	4		Machinability group target
2	FEMIN	Numeric	7	3	Minimum amount of iron (%)
3	FEMAX	Numeric	7	3	Maximum amount of iron (%)
4	CMIN	Numeric	7	3	Minimum amount of carbon (%)
5	CMAX	Numeric	7	3	Maximum amount of carbon (%)
6	CUMIN	Numeric	7	3	Minimum amount of copper (%)
7	CUMAX	Numeric	7	3	Maximum amount of copper (%)
8	NIMIN	Numeric	7	3	Minimum amount of nicekl (%)
9	NIMAX	Numeric	7	3	Maximum amount of nickel (%)
10	CRMIN	Numeric	7	3	Minimum amount of chromium (%)
11	CRMAY	Numeric	7	3	Maximum amount of chromium (%)
12	MNMIN	Numeric	7	3	Minimum amount of manganese (%)
13	MNMAX	Numeric	7	3	Maximum amount of manganese (%)
14	PMIN	Numeric	7	3	Minimum amount of phosphorus (%)
15	PMAX	Numeric	7	3	Maximum amount of phosphorus (%)
16	SMIN	Numeric	7	3	Minimum amount of sulphur (%)
17	SMAX	Numeric	7	3	Maximum amount of sulphur (%)
18	MOMIN	Numeric	7	3	Minimum amount of molybdenum (%)
19	MOMAX	Numeric	7	3	Maximum amount of molybdenum (%)
20	TIMIN	Numeric	7	3	Minimum amount of titanium (%)
21	TIMAX	Numeric	7	3	Maximum amount of titanium (%)
22	PBMIN	Numeric	7	3	Minimum amount of lead (%)
23	PBMAX	Numeric	7	3	Maximum amount of lead (%)
24	COMIN	Numeric	7	3	Minimum amount of cobalt (%)
25	COMAX	Numeric	7	3	Maximum amount of cobalt (%)
26	BMIN	Numeric	7	3	Minimum amount of boron (%)
27	BMAX	Numeric	7	3	Maximum amount of boron (%)
28	NBMIN	Numeric	7	3	Minimum amount of niobium (%)
29	NBMAX	Numeric	7	3	Maximum amount of niobium (%)
30	WMIN	Numeric	7	3	Minimum amount of tungsten (%)
31	WMAX	Numeric	7	3	Maximum amount of tungsten (%)
32	VMIN	Numeric	7	3	Minimum amount of vanadium (%)
33	VMAX	Numeric	7	3	Maximum amount of vanadium (%)
34	ALMIN	Numeric	7	3	Minimum amount of aluminium (%)
35	ALMAX	Numeric	7	3	Maximum amount of aluminium (%)
36	SIMIN	Numeric	7	3	Minimum amount of silicon (%)
37	SIMAX	Numeric	7	3	Maximum amount of silicon (%)
38	NMIN	Numeric	7	3	Minimum amount of nitrogen (%)
39	NMAX	Numeric	7	3	Maximum amount of nitrogen (%)

Structure for table: gr_name.dbf

Table description: Store names and numbers of all material groups

Number of data records: 50

Field	Name	Type	Width	Decimals	Description
1	MAT_NO	Numeric	5		Material group
2	GRP_NAME	Character	50		Material group description

Structure for table: machines.dbf

Table description: Machine tool details (from catalogues)

Number of data records: 5

Field	Name	Type	Width	Decimals	Description
1	REFNUM	Numeric	5		Machine reference number
2	MACH_DESC	Character	80		Description of machine
3	LONGTRAV	Numeric	10		Longitudinal travel (mm)
4	CROSSTRAV	Numeric	10		Cross travel (mm)
5	HEADTRAV	Numeric	10		Head travel (mm)
6	SPIN2TABLE	Numeric	10		Spindle to table distance (mm)
7	SPIN2COL	Numeric	10		Spindle to column distance (mm)
8	SYSTRES	Numeric	10	5	System resolution (mm)
9	MACHRES	Numeric	10	5	Machine resolution (mm)
10	MIN_RPM	Numeric	10		Minimum spindle speed (RPM)
11	MAX_RPM	Numeric	10		Maximum spindle speed (RPM)
12	S_OUT_DIAM	Numeric	10		Spindle outer diameter (mm)
13	S_IN_DIAM	Numeric	10		Spindle inner diameter (mm)
14	POWER	Numeric	10		Power rating (W)
15	EFFIC	Numeric	3		Machine efficiency
16	MIN_FEED	Numeric	10	5	Minimum feed rate (m/min)
17	MAX_FEED	Numeric	10	5	Maximum feed rate (m/min)
18	MAX_T_DIAM	Numeric	10		Maximum tool diameter (mm)
19	MAX_T_HITE	Numeric	10		Maximum tool height (mm)
20	RAPIDTRAV	Numeric	10	5	Rapid traverse rate (m/min)
21	COSTRATE	Numeric	10		Machine cost rate (£/hour)
22	MAX_TORS	Numeric	10	5	Maximum spindle torque (Nm)
23	MAX_DEFL	Numeric	10	5	Maximum spindle deflection (mm)
24	POW_THRESH	Numeric	10		Power threshold (RPM)

Structure for table: millins.dbf

Table description: Milling insert details (from Seco Tools)

Number of data records: 3819

Field	Name	Type	Width	Decimals	Description
1	PRDCAT	Character	5		Product catalogue
2	MREF	Character	20		Insert reference code
3	PARTNO	Character	25		Insert part number
4	PRDTYPE	Character	5		Product type description
5	DESC	Character	30		Insert description
6	GRADE	Character	10		Insert grade
7	IEHAND	Character	5		Handedness of insert
8	FITTYPE	Character	30		Fitting type
9	DIM1	Numeric	8	3	Generic dimension (varies by insert type)
10	DIM2	Numeric	8	3	Generic dimension (varies by insert type)
11	INSLNGTH	Numeric	3		Insert edge length (mm)
12	INSCOST	Numeric	7	3	Insert cost (£)
13	IDEAL_HZM	Numeric	3		Ideal Hzm for chipbreaker (mm)
14	INS_AVAIL	Logical	1		Availability flag
15	WIPERWIDTH	Numeric	5	2	Width of wiper flat, if present (mm)
16	NOSERADIUS	Numeric	5	2	Insert nose radius (mm)

Structure for table: millcut.dbf

Table description: Milling cutter details (from Seco Tools)

Number of data records: 532

Field	Name	Type	Width	Decimals	Description
1	PRDCAT	Character	5		Product catalogue (milling, turning etc)
2	MREF	Character	20		Cutter reference code
3	MAKER	Character	20		Manufacturer
4	PARTNO	Character	25		Cutter part number
5	AVAILABLE	Logical	1		Availability flag
6	CUT_CODES	Character	10		Feasible operation codes
7	CUTTYPE	Character	20		General cutter type
8	DESC	Character	30		Cutter description
9	WEIGHT	Numeric	8	3	Weight (kg)
10	GAUGEL	Numeric	8	3	Gauge length (mm)
11	TOOLDIA	Numeric	8	3	Tool cutting diameter (mm)
12	FITTYPE	Character	30		Fitting type
13	KFACTOR	Numeric	8	3	Number of cutting teeth
14	TINSQTY	Numeric	8	3	Total number of inserts
15	DIM1	Numeric	8	3	Generic dimension (varies by cutter type)
16	APPRANGLE	Numeric	8	3	Approach angle (°)
17	MAXDEPTH	Numeric	8	3	Maximum cutting depth (mm)
18	DIM4	Numeric	8	3	Generic dimension (varies by cutter type)
19	MAXWID	Numeric	8	3	Maximum width of cutter (mm)
20	GAMMAO_MIN	Numeric	6	1	Minimum cutting rake (°)
21	GAMMAO_MAX	Numeric	6	1	Maximum cutting rake (°)
22	GAMMAP_MIN	Numeric	6	1	Minimum axial rake (°)
23	GAMMAP_MAX	Numeric	6	1	Maximum axial rake (°)
24	GAMMAF_MIN	Numeric	6	1	Minimum radial rake (°)
25	GAMMAF_MAX	Numeric	6	1	Maximum radial rake (°)
26	STHZM	Numeric	8	3	Minimum average chip thickness (mm)
27	SPHZM	Numeric	8	3	Average chip thickness step size (mm)
28	NSHZM	Numeric	8	3	Number of steps in Hzm
29	TOOLHEIGHT	Numeric	10	2	Overall tool height (mm)
30	CUTTERCOST	Numeric	8	3	Cutter cost (£)
31	MOUNTTIME	Numeric	5		Typical mounting time (min)
32	REMOVETIME	Numeric	5		Typical removal time (min)
33	INSCHGTIME	Numeric	5		Typical insert change time (min)

Structure for table: optypes.dbf

Table description: Names, codes and required dimensions for all feasible machining operations

Number of data records: 13

Field	Name	Type	Width	Decimals	Description
1	OPNAME	Character	26		Operation description
2	NUM_DIMS	Numeric	3		Number of dimensions
3	DIM1_NAME	Character	20		Name of first dimension
4	DIM1_UNIT	Character	10		Units of first dimension
5	DIM2_NAME	Character	20		Name of second dimension
6	DIM2_UNIT	Character	10		Units of second dimension
7	DIM3_NAME	Character	20		Name of third dimension
8	DIM3_UNIT	Character	10		Units of third dimension
9	DIM4_NAME	Character	20		Name of fourth dimension
10	DIM4_UNIT	Character	10		Units of fourth dimension
11	DIM5_NAME	Character	20		Name of fifth dimension
12	DIM5_UNIT	Character	10		Units of fifth dimension
13	DIM6_NAME	Character	20		Name of sixth dimension
14	DIM6_UNIT	Character	10		Units of sixth dimension
15	OP_NUM	Numeric	3		Operation number
16	OP_CODE	Character	1		Single character operation code

Structure for table: results.dbf

Table description: Store results of machinability assessor

Number of data records: 52

Date of last update: 24/08/95

Field	Name	Type	Width	Decimals	Description
1	R_DESC	Character	50		Description of operation and material
2	R_MATGR	Numeric	5		Material group
3	R_MACHGR	Numeric	5		Machinability group
4	R_HARDNESS	Numeric	5		Surface hardness (BHn)
5	R_OPTYPE	Numeric	3		Operation code
6	R_DOC	Numeric	6	2	Depth of cut (mm)
7	R_V	Numeric	5		Cutting velocity (m/min)
8	R_S	Numeric	10	5	Feed per tooth (mm)
9	TOOL_MAT	Character	20		ISO tool material code

Structure for table: seco_grp.dbf

Table description: Relate Seco material groups to OPTIMUM material groups

Number of data records: 100

Field	Name	Type	Width	Decimals	Description
1	GROUP_NO	Numeric	9		Material group number
2	MACH_GRP	Numeric	10		Machinability group number
3	SECO_GRP	Numeric	3		Seco group number
4	GRP_NAME	Character	50		Material group description
5	MACH_NAME	Character	50		Machinability group description
6	SECO_NAME	Character	200		Seco group description

Structure for table: steels.dbf

Table description: Material descriptions including chemical compositions

Number of data records: 710

Field	Name	Type	Width	Decimals	Description
1	GROUP_NO	Numeric	9		Material group
2	GRP_NAME	Character	50		Material group description
3	MACH_GRP	Numeric	10		Machinability group
4	SECO_GRP	Numeric	3		Seco material group
5	MATERIAL_D	Character	30		Standard material designation (AISI)
6	FE	Numeric	6	2	Percentage composition of iron
7	C	Numeric	6	2	Percentage composition of carbon
8	CU	Numeric	6	2	Percentage composition of copper
9	NI	Numeric	6	2	Percentage composition of nickel
10	CR	Numeric	6	2	Percentage composition of chromium
11	MN	Numeric	6	2	Percentage composition of manganese
12	P	Numeric	6	2	Percentage composition of phosphorus
13	S	Numeric	6	2	Percentage composition of sulphur
14	MO	Numeric	6	2	Percentage composition of molybdenum
15	TI	Numeric	6	2	Percentage composition of titanium
16	PB	Numeric	6	2	Percentage composition of lead
17	CO	Numeric	6	2	Percentage composition of cobalt
18	B	Numeric	6	2	Percentage composition of boron
19	NB	Numeric	6	2	Percentage composition of niobium
20	W	Numeric	6	2	Percentage composition of tungsten
21	V	Numeric	6	2	Percentage composition of vanadium
22	AL	Numeric	6	2	Percentage composition of aluminium
23	SI	Numeric	6	2	Percentage composition of silicon
24	N	Numeric	6	2	Percentage composition of nitrogen

Structure for table: toolgeom.dbf

Table description: Tool geometry selection rules

Number of data records: 1

Field	Name	Type	Width	Decimals	Description
1	SECOGROUPS	Character	60		List of Seco material groups
2	MAX_GAMMAO	Numeric	7	2	Maximum cutting rake (°)
3	MIN_GAMMAO	Numeric	7	2	Minimum cutting rake (°)
4	MAX_GAMMAP	Numeric	7	2	Maximum axial rake (°)
5	MIN_GAMMAP	Numeric	7	2	Minimum axial rake (°)
6	MAX_GAMMAF	Numeric	7	2	Maximum radial rake (°)
7	MIN_GAMMAF	Numeric	7	2	Minimum radial rake (°)

Structure for table: toolist.dbf

Table description: Store lists of suggested tools with associated cutting data

Number of data records: 166

Field	Name	Type	Width	Decimals	Description
1	T_REFNUM	Numeric	6		Tool list number
2	T_RANKING	Numeric	4		Ranking within tool list
3	T_CUTMREF	Character	20		Cutter reference code
4	T_INSMREF	Character	20		Insert reference code
5	T_COMMENT1	Character	60		Note
6	T_COMMENT2	Character	60		Note
7	T_TOTCOST	Numeric	10	2	Total cost (£)
8	T_MRR	Numeric	10	4	Metal removal rate (mm ³ /min)
9	T_CUTTIME	Numeric	10	2	Cutting time (min)
10	T_NCUTTIME	Numeric	10	2	Non-cutting time (min)
11	T_EXPTLIFE	Numeric	10	4	Expected tool life (min)
12	T_V	Numeric	10	2	Cutting velocity (m/min)
13	T_AA	Numeric	10	2	Axial depth of cut (mm)
14	T_AR	Numeric	10	2	Radial depth of cut (mm)
15	T_SZ	Numeric	10	2	Feed per tooth (mm)
16	T_HZM	Numeric	10	2	Average chip thickness (mm)
17	T_RPM	Numeric	10	2	Spindle speed (RPM)
18	T_TABLFEED	Numeric	10	2	Table feed (mm/min)
19	T_POWER	Numeric	10	2	Power required (W)
20	T_VFORCE	Numeric	10	2	Tangential force component (N)
21	T_RFORCE	Numeric	10	2	Radial force component (N)
22	T_AFORCE	Numeric	10	2	Axial force component (N)
23	T_TOTFORCE	Numeric	10	2	Resultant cutting force (N)
24	T_APASSES	Numeric	4		Number of axial passes
25	T_AXDEPTH	Numeric	10	2	Total axial depth of cut (mm)
26	T_RPASSES	Numeric	4		Number of radial passes
27	T_RADEPTH	Numeric	10	2	Total radial depth of cut (mm)
28	T_CUTDIST	Numeric	10	2	Total cutting distance (mm)
29	T_NCUTDIST	Numeric	10	2	Total non-cutting distance (mm)
30	T_RADUSAGE	Numeric	5	2	Percentage radial usage
31	T_TLIFE	Numeric	10	4	Tool life (min)
32	T_AXUSAGE	Numeric	5	2	Percentage axial usage
33	T_WEIGHT	Numeric	20	10	Sort weighting value
34	T_ENGANG	Numeric	5	2	Engagement angle (°)
35	T_IDEALHZM	Numeric	4		Ideal Hzm for cutter (mm)
36	T_NOTES	Memo	10		Notes
37	S_V	Numeric	10	2	Secondary pass information....
38	S_AA	Numeric	10	2	
39	S_AR	Numeric	10	2	
40	S_SZ	Numeric	10	2	
41	S_HZM	Numeric	10	2	
42	S_RPM	Numeric	10	2	
43	S_TABLFEED	Numeric	10	2	
44	S_MRR	Numeric	10	2	
45	S_POWER	Numeric	10	2	
46	S_APASSES	Numeric	4		
47	S_AXDEPTH	Numeric	10	2	
48	S_RPASSES	Numeric	4		
49	S_RADEPTH	Numeric	10	2	
50	S_RADUSAGE	Numeric	5	2	
51	S_AXUSAGE	Numeric	5	2	
52	S_ENGANG	Numeric	5	2	
53	S_TLIFE	Numeric	10	4	

Structure for table: xrefinsm.dbf

Table description: Table to relate holders table with inserts table (from Seco Tools)

Number of data records: 6173

Field	Name	Type	Width	Decimals	Description
1	MREF	Character	20		Cutter reference code
2	SEARCH	Character	25		Insert reference code search fragment
3	INSQTY	Numeric	2		Total number of inserts

Structure for table: var_rank.dbf

Table description: summary of reduced variety tool set

Number of data records: 39

Field	Name	Type	Width	Decimals	Description
1	R_REFNUM	Numeric	4		Variety reduction exercise number
2	R_RANKING	Numeric	6		Tool set ranking number
3	SET_NUM	Numeric	6		Tool set index number
4	TOTALSCORE	Numeric	12	4	Total performance weight for tool set

Structure for table: var_sols.dbf

Table description: tool item in reduced variety tool set

Number of data records: 104

Field	Name	Type	Width	Decimals	Description
1	R_REFNUM	Numeric	6		Variety reduction exercise number
2	SET_NUM	Numeric	6		Tool set number
3	LIST_NUM	Numeric	6		Tool list number
4	TOOLNUM	Numeric	6		Tool number within tool list
5	WEIGHTING	Numeric	20	10	Weighting value for tool
6	NOTES	Character	254		Notes

Structure for table: toolsumm.dbf

Table description: Summary information for tool lists

Number of data records: 5

Field	Name	Type	Width	Decimals	Description
1	W_REFNUM	Numeric	6		Tool list reference number
2	W_NOTES	Character	120		Tool list general notes
3	W_MATGRP	Numeric	3		Material group
4	W_MACHGRP	Numeric	3		Machinability group
5	W_MATDESC	Character	100		Material description
6	MACHINENUM	Numeric	10		Machine reference number
7	MACH_DESC	Character	70		Machine description
8	W_OPNUM	Numeric	6		Operation reference number
9	W_COMPNUM	Numeric	6		Component reference number

Appendix B

Material groupings

The material groups used in the OPTIMUM system (based upon those in the *Machining Data Handbook*) are shown in Table B.1.

Material Group	Group Name	Machinability Group	Machinability Group Name
1	Free Machining Carbon Steels, Wrought	1	Low Carbon Resulfurized
1	Free Machining Carbon Steels, Wrought	2	Low Carbon Resulfurized
1	Free Machining Carbon Steels, Wrought	3	Low Carbon Resulfurized
1	Free Machining Carbon Steels, Wrought	4	Medium Carbon Resulfurized
1	Free Machining Carbon Steels, Wrought	5	Low Carbon Leaded
1	Free Machining Carbon Steels, Wrought	6	Low Carbon Leaded
1	Free Machining Carbon Steels, Wrought	7	Medium Carbon Leaded
1	Free Machining Carbon Steels, Wrought	8	Medium Carbon Leaded
2	Carbon Steels, Wrought	9	Low Carbon
2	Carbon Steels, Wrought	10	Low Carbon
2	Carbon Steels, Wrought	11	Medium Carbon
2	Carbon Steels, Wrought	12	Medium Carbon
2	Carbon Steels, Wrought	13	High Carbon
3	Carbon & Ferritic Alloy Steels (High Temp. Service)	14	Machinability group 14
3	Carbon & Ferritic Alloy Steels (High Temp. Service)	15	Machinability group 15
3	Carbon & Ferritic Alloy Steels (High Temp. Service)	16	Machinability group 16
4	Free Machining Alloy Steels, Wrought	17	Medium Carbon Resulfurized
4	Free Machining Alloy Steels, Wrought	18	Medium and High Carbon Leaded
5	Alloy Steels, Wrought	19	Low Carbon
5	Alloy Steels, Wrought	20	Medium Carbon
5	Alloy Steels, Wrought	21	Medium Carbon
5	Alloy Steels, Wrought	22	Medium Carbon
5	Alloy Steels, Wrought	23	High Carbon
6	High Strength Steels, Wrought	24	Machinability group 24
6	High Strength Steels, Wrought	25	Machinability group 25
6	High Strength Steels, Wrought	26	Machinability group 26
7	Maraging Steels, Wrought	27	Machinability group 27
7	Maraging Steels, Wrought	28	Machinability group 28
8	Tool Steels, Wrought	29	High Speed
8	Tool Steels, Wrought	30	High Speed
8	Tool Steels, Wrought	31	High Speed
8	Tool Steels, Wrought	32	Hot Work
8	Tool Steels, Wrought	33	Hot Work
8	Tool Steels, Wrought	34	Cold Work
8	Tool Steels, Wrought	35	Cold Work
8	Tool Steels, Wrought	36	Shock Resisting
8	Tool Steels, Wrought	37	Mold
8	Tool Steels, Wrought	38	Mold
8	Tool Steels, Wrought	39	Special Purpose
8	Tool Steels, Wrought	40	Special Purpose
8	Tool Steels, Wrought	41	Water Hardening
9	Nitriding Steels, Wrought	42	Machinability group 42
10	Armour Plate, Ship Plate, Aircraft Plate, Wrought	43	Machinability group 43
10	Armour Plate, Ship Plate, Aircraft Plate, Wrought	44	Machinability group 44
11	Structural Steels, Wrought	45	Machinability group 45
11	Structural Steels, Wrought	46	Machinability group 46
11	Structural Steels, Wrought	47	Machinability group 47
11	Structural Steels, Wrought	48	Machinability group 48
11	Structural Steels, Wrought	49	Machinability group 49
11	Structural Steels, Wrought	50	Machinability group 50
11	Structural Steels, Wrought	51	Machinability group 51
12	Free Machining Stainless Steels, Wrought	52	Ferritic

Material Group	Group Name	Machinability Group	Machinability Group Name
12	Free Machining Stainless Steels, Wrought	53	Austenitic
12	Free Machining Stainless Steels, Wrought	54	Martensitic
13	Stainless Steels, Wrought	55	Ferritic
13	Stainless Steels, Wrought	56	Austenitic
13	Stainless Steels, Wrought	57	Austenitic
13	Stainless Steels, Wrought	58	Austenitic
13	Stainless Steels, Wrought	59	Martensitic
13	Stainless Steels, Wrought	60	Martensitic
13	Stainless Steels, Wrought	61	Martensitic
14	Precipitation Hardening Stainless Steels, Wrought	62	Machinability group 62
15	Carbon Steels, Cast	63	Low Carbon
15	Carbon Steels, Cast	64	Medium Carbon
16	Alloy Steels, Cast	65	Low Carbon
16	Alloy Steels, Cast	66	Medium Carbon
17	Tool Steels, Cast	67	Hot Work
17	Tool Steels, Cast	68	Cold Work
17	Tool Steels, Cast	69	Cold Work
17	Tool Steels, Cast	70	Shock Resisting
18	Stainless Steels, Cast	71	Ferritic
18	Stainless Steels, Cast	72	Austenitic
18	Stainless Steels, Cast	73	Austenitic
18	Stainless Steels, Cast	74	Austenitic
18	Stainless Steels, Cast	75	Austenitic
18	Stainless Steels, Cast	76	Martensitic
19	Precipitation Hardening Stainless Steels, Cast	77	Machinability group 77
20	Austenitic Manganese Steels, Cast	78	Machinability group 78
21	Cast Grey Irons	79	Ferritic
21	Cast Grey Irons	80	Pearlitic-Ferritic
21	Cast Grey Irons	81	Pearlitic
21	Cast Grey Irons	82	Pearlitic plus Free Carbides
21	Cast Grey Irons	83	Pearlitic or Acicular plus Free Carbides
21	Cast Grey Irons	84	Austenitic (NI-RESIST)
21	Cast Grey Irons	85	Austenitic (NI-RESIST)
21	Cast Grey Irons	86	Austenitic (NI-RESIST)
22	Compacted Graphite Cast Irons	87	Machinability group 87
23	Ductile Cast Irons	88	Ferritic
23	Ductile Cast Irons	89	Ferritic-Pearlitic
23	Ductile Cast Irons	90	Pearlitic-Martensitic
23	Ductile Cast Irons	91	Martensitic
23	Ductile Cast Irons	92	Austenitic (NI-RESIST Ductile)
23	Ductile Cast Irons	93	Austenitic (NI-RESIST Ductile)
24	Malleable Cast Irons	94	Ferritic
24	Malleable Cast Irons	95	Pearlitic
24	Malleable Cast Irons	96	Tempered Martensite
24	Malleable Cast Irons	97	Tempered Martensite
24	Malleable Cast Irons	98	Tempered Martensite
24	Malleable Cast Irons	99	Tempered Martensite
25	White Cast Irons	100	Machinability group 100
25	White Cast Irons	101	Machinability group 101
27	Chromium-nickel Alloy Castings	102	Machinability group 102
28	Aluminium Alloys, Wrought	103	Machinability group 103
29	Aluminium Alloys, Cast	104	Sand and Permanent Mold
29	Aluminium Alloys, Cast	105	Die Castings
29	Aluminium Alloys, Cast	106	Die Castings
29	Aluminium Alloys, Cast	107	Die Castings
30	Magnesium Alloys, Wrought	108	Machinability group 108
31	Magnesium Alloys, Cast	109	Machinability group 109
32	Titanium Alloys, Wrought	110	Commercially Pure
32	Titanium Alloys, Wrought	111	Commercially Pure
32	Titanium Alloys, Wrought	112	Commercially Pure
32	Titanium Alloys, Wrought	113	Alpha and Alpha-Beta Alloys
32	Titanium Alloys, Wrought	114	Alpha and Alpha-Beta Alloys
32	Titanium Alloys, Wrought	115	Alpha and Alpha-Beta Alloys
32	Titanium Alloys, Wrought	116	Alpha and Alpha-Beta Alloys
32	Titanium Alloys, Wrought	117	Alpha and Alpha-Beta Alloys
32	Titanium Alloys, Wrought	118	Alpha and Alpha-Beta Alloys
32	Titanium Alloys, Wrought	119	Beta Alloys
33	Titanium Alloys, Cast	120	Commercially Pure

Material Group	Group Name	Machinability Group	Machinability Group Name
33	Titanium Alloys, Cast	121	Commercially Pure
33	Titanium Alloys, Cast	122	Alpha and Alpha-Beta Alloys
34	Copper Alloys, Wrought	123	Machinability group 123
34	Copper Alloys, Wrought	124	Machinability group 124
34	Copper Alloys, Wrought	125	Machinability group 125
35	Copper Alloys, Cast	126	Machinability group 126
35	Copper Alloys, Cast	127	Machinability group 127
35	Copper Alloys, Cast	128	Machinability group 128
36	Nickel Alloys, Wrought And Cast	129	Machinability group 129
36	Nickel Alloys, Wrought And Cast	130	Machinability group 130
36	Nickel Alloys, Wrought And Cast	131	Machinability group 131
37	Beryllium Nickel Alloys, Wrought And Cast	132	Machinability group 132
38	Nitinol Alloys, Wrought	133	Machinability group 133
38	Nitinol Alloys, Wrought	134	Machinability group 134
38	Nitinol Alloys, Wrought	135	Machinability group 135
39	High Temperature Alloys	136	Nickel Base, Wrought
39	High Temperature Alloys	137	Nickel Base, Wrought
39	High Temperature Alloys	138	Nickel Base, Wrought
39	High Temperature Alloys	139	Nickel Base, Wrought
39	High Temperature Alloys	140	Nickel Base, Wrought
39	High Temperature Alloys	141	Nickel Base, Cast
39	High Temperature Alloys	142	Nickel Base, Cast
39	High Temperature Alloys	143	Cobalt Base, Wrought
39	High Temperature Alloys	144	Cobalt Base, Wrought
39	High Temperature Alloys	145	Iron Base, Wrought
40	Refractory Alloys, Wrought, Cast, P/m	146	Columbium
40	Refractory Alloys, Wrought, Cast, P/m	147	Molybdenum
40	Refractory Alloys, Wrought, Cast, P/m	148	Tantalum
40	Refractory Alloys, Wrought, Cast, P/m	149	Tungsten, 85% Density
40	Refractory Alloys, Wrought, Cast, P/m	150	Tungsten, 93% Density
40	Refractory Alloys, Wrought, Cast, P/m	151	Tungsten, 96%/100% Density
40	Refractory Alloys, Wrought, Cast, P/m	152	Tungsten - 2 Thoria
40	Refractory Alloys, Wrought, Cast, P/m	153	Tungsten Alloys
40	Refractory Alloys, Wrought, Cast, P/m	154	Tungsten Alloys
40	Refractory Alloys, Wrought, Cast, P/m	155	Tungsten Alloys
41	Zinc Alloys, Cast	156	Machinability group 156
42	Lead Alloys, Cast	157	Lead Babbit Alloys
42	Lead Alloys, Cast	158	Lead Antimony Alloys
43	Tin Alloys, Cast	159	Tin Babbit Alloys
44	Uranium, Wrought	160	Machinability group 160
45	Zirconium Alloys, Wrought	161	Machinability group 161
46	Manganese, Wrought	162	Machinability group 162
47	Powder Metal Alloys	163	Copper
47	Powder Metal Alloys	164	Brasses
47	Powder Metal Alloys	165	Bronzes
47	Powder Metal Alloys	166	Copper-Nickel Alloys
47	Powder Metal Alloys	167	Nickel and Nickel Alloys
47	Powder Metal Alloys	168	Refractory Metal Base
47	Powder Metal Alloys	169	Irons
47	Powder Metal Alloys	170	Steels
47	Powder Metal Alloys	171	Stainless Steels
47	Powder Metal Alloys	172	Aluminium Alloys
48	Machinable Carbides	173	Machinability group 173
50	Free Machining Magnetic Alloys	174	Machinability group 174
50	Free Machining Magnetic Alloys	175	Machinability group 175
51	Magnetic Alloys	176	Machinability group 176
51	Magnetic Alloys	177	Machinability group 177
52	Free Machining Controlled Expansion Alloys	178	Machinability group 178
53	Controlled Expansion Alloys	179	Machinability group 179

Table B.1: Material groups and subgroups

The Seco designated material groups are shown in Table B.2

Material group	Mild and alloy steel
1	Very soft "tacky" steels. Purely ferritic steels.
2	Free-cutting steels. Other than stainless free-cutting steels.
3	Structural steels, ordinary carbon steels. Carbon steels with low to medium carbon contents (<0.5%C).
4	High carbon steels, ordinary low-alloy steels. Medium-hard steels for toughening. high carbon steels (>0.5%C). Ferritic and martensitic stainless steels.
5	Normal tool steels. Harder steels for toughening. Martensitic stainless steels.
6	Difficult tools steels. High-alloy steels with high hardness. Martensitic stainless steels.
7	Difficult high-strength steels. Hardened steels from group 3-6. Martensitic stainless steels.
Stainless steel	
8	Easy-cutting stainless steels. Free-cutting stainless steels. Calcium treated stainless steels.
9	Moderately difficult stainless steels. Austenitic and duplex.
10	Stainless steels difficult to machine. Austenitic and duplex.
Cast iron	
12	Cast iron with medium hardness. Grey iron.
13	Low-alloy cast iron with low hardness. Malleable iron castings. Nodular iron.
14	Medium-hard alloy cast iron. Moderately difficult malleable castings. Nodular iron.
15	High-alloy cast iron difficult to machine. Difficult malleable iron castings. Nodular iron.
Other materials	
16	Free-cutting non-ferrous materials. Aluminium <16% Si Brass, zinc, magnesium.
17	Non-ferrous materials. Aluminium >16% Si Aluminium bronze, cupro-nickel.
20	Nickel cobalt and iron based superalloys <30Rc Incoloy 800, Inconel 601, 617, 625, Monel 400.
21	Nickel cobalt and iron based superalloys >30Rc Inconel 718, 750-X, Incolo 925, Monel K-500.
22	Titanium based alloys. Ti-6Al-4V

Table B.2: Seco material groups

Appendix C

Material classification rules

This Appendix includes a selection of the material classification rules generated for the OPTIMUM system from the standard materials data table. The syntax is the logical rule form used by the Crystal expert system shell and the rules are presented in this form as it is rather more readable, although longer, than the tabulated form used by the OPTIMUM software.

Each rule expresses in one or more clauses the conditions placed upon the chemical composition of a material for it to be categorized within one of the machinability groups listed in Appendix B.

```
Group_No is 1
  IF
    AND Si is less than 0.275
    AND NOT P is less than 0.025
    AND NOT P is less than 0.035
    AND C is less than 0.295
    AND NOT S is less than 0.075
    AND Fe is less than 98.940
    AND S is less than 0.225
    AND DO: Conclusion Display

  OR
    AND Si is less than 0.275
    AND NOT P is less than 0.025
    AND NOT P is less than 0.035
    AND C is less than 0.295
    AND NOT S is less than 0.075
    AND Fe is less than 98.940
    AND NOT S is less than 0.225
    AND NOT C is less than 0.160
    AND Fe is less than 98.305
    AND DO: Conclusion Display

Group_No is 2
  IF
    AND Si is less than 0.275
    AND NOT P is less than 0.025
    AND NOT P is less than 0.035
    AND C is less than 0.295
    AND NOT S is less than 0.075
    AND Fe is less than 98.940
    AND NOT S is less than 0.225
    AND C is less than 0.160
    AND NOT S is less than 0.265
    AND DO: Conclusion Display

Group_No is 3
  IF
    AND Si is less than 0.275
    AND NOT P is less than 0.025
    AND NOT P is less than 0.035
    AND C is less than 0.295
    AND NOT S is less than 0.075
    AND NOT Fe is less than 98.940
    AND DO: Conclusion Display

Group_No is 4
  IF
    AND Si is less than 0.275
    AND NOT P is less than 0.025
    AND NOT P is less than 0.035
    AND NOT C is less than 0.295
```

```

AND      C is less than 0.575
AND      Fe is less than 98.515
AND      NOT S is less than 0.075
AND      Pb is less than 0.125
AND      DO: Conclusion Display

OR       Si is less than 0.275
AND      NOT P is less than 0.025
AND      NOT P is less than 0.035
AND      NOT C is less than 0.295
AND      C is less than 0.575
AND      NOT Fe is less than 98.515
AND      S is less than 0.075
AND      Fe is less than 98.620
AND      C is less than 0.455
AND      DO: Conclusion Display

OR       Si is less than 0.275
AND      NOT P is less than 0.025
AND      NOT P is less than 0.035
AND      NOT C is less than 0.295
AND      C is less than 0.575
AND      NOT Fe is less than 98.515
AND      NOT S is less than 0.075
AND      DO: Conclusion Display

Group_No is 5
IF       Si is less than 0.275
AND      NOT P is less than 0.025
AND      NOT P is less than 0.035
AND      C is less than 0.295
AND      NOT S is less than 0.075
AND      Fe is less than 98.940
AND      NOT S is less than 0.225
AND      NOT C is less than 0.160
AND      NOT Fe is less than 98.305
AND      DO: Conclusion Display

Group_No is 6
IF       Si is less than 0.275
AND      NOT P is less than 0.025
AND      NOT P is less than 0.035
AND      C is less than 0.295
AND      NOT S is less than 0.075
AND      Fe is less than 98.940
AND      NOT S is less than 0.225
AND      C is less than 0.160
AND      S is less than 0.265
AND      DO: Conclusion Display

Group_No is 7
IF       Si is less than 0.275
AND      NOT P is less than 0.025
AND      NOT P is less than 0.035
AND      NOT C is less than 0.295
AND      C is less than 0.575
AND      Fe is less than 98.515
AND      S is less than 0.075
AND      NOT Fe is less than 98.405
AND      DO: Conclusion Display

Group_No is 8
IF       Si is less than 0.275
AND      NOT P is less than 0.025
AND      NOT P is less than 0.035
AND      NOT C is less than 0.295
AND      C is less than 0.575
AND      Fe is less than 98.515
AND      NOT S is less than 0.075
AND      NOT Pb is less than 0.125
AND      DO: Conclusion Display

Group_No is 9
IF       Si is less than 0.275
AND      NOT P is less than 0.025
AND      NOT P is less than 0.035
AND      C is less than 0.295
AND      S is less than 0.075
AND      NOT Fe is less than 99.170
AND      DO: Conclusion Display

```

```

Group_No is 10
  IF      Si is less than 0.275
    AND   NOT P is less than 0.025
    AND   NOT P is less than 0.035
    AND   C is less than 0.295
    AND   S is less than 0.075
    AND   Fe is less than 99.170
    AND   Si is less than 0.100
    AND   NOT Fe is less than 98.370
    AND   C is less than 0.235
    AND   DO: Conclusion Display

  OR      Si is less than 0.275
    AND   NOT P is less than 0.025
    AND   NOT P is less than 0.035
    AND   C is less than 0.295
    AND   S is less than 0.075
    AND   Fe is less than 99.170
    AND   Si is less than 0.100
    AND   NOT Fe is less than 98.370
    AND   NOT C is less than 0.235
    AND   NOT Fe is less than 98.790
    AND   DO: Conclusion Display

Group_No is 11
  IF      Si is less than 0.275
    AND   NOT P is less than 0.025
    AND   NOT P is less than 0.035
    AND   C is less than 0.295
    AND   S is less than 0.075
    AND   Fe is less than 99.170
    AND   Si is less than 0.100
    AND   Fe is less than 98.370
    AND   NOT Fe is less than 98.205
    AND   DO: Conclusion Display

  OR      Si is less than 0.275
    AND   NOT P is less than 0.025
    AND   NOT P is less than 0.035
    AND   C is less than 0.295
    AND   S is less than 0.075
    AND   Fe is less than 99.170
    AND   Si is less than 0.100
    AND   NOT Fe is less than 98.370
    AND   NOT C is less than 0.235
    AND   Fe is less than 98.790
    AND   DO: Conclusion Display

  OR      Si is less than 0.275
    AND   NOT P is less than 0.025
    AND   NOT P is less than 0.035
    AND   NOT C is less than 0.295
    AND   C is less than 0.575
    AND   NOT Fe is less than 98.515
    AND   S is less than 0.075
    AND   Fe is less than 98.620
    AND   NOT C is less than 0.455
    AND   DO: Conclusion Display

  OR      Si is less than 0.275
    AND   NOT P is less than 0.025
    AND   NOT P is less than 0.035
    AND   NOT C is less than 0.295
    AND   C is less than 0.575
    AND   NOT Fe is less than 98.515
    AND   S is less than 0.075
    AND   NOT Fe is less than 98.620
    AND   DO: Conclusion Display

Group_No is 12
  IF      Si is less than 0.275
    AND   NOT P is less than 0.025
    AND   NOT P is less than 0.035
    AND   C is less than 0.295
    AND   S is less than 0.075
    AND   Fe is less than 99.170
    AND   Si is less than 0.100
    AND   Fe is less than 98.370
    AND   Fe is less than 98.205

```

```

AND      DO: Conclusion Display

OR
AND      Si is less than 0.275
AND      NOT P is less than 0.025
AND      NOT P is less than 0.035
AND      NOT C is less than 0.295
AND      C is less than 0.575
AND      Fe is less than 98.515
AND      S is less than 0.075
AND      Fe is less than 98.405
AND      DO: Conclusion Display

Group_No is 13
IF
AND      Si is less than 0.275
AND      NOT P is less than 0.025
AND      NOT P is less than 0.035
AND      NOT C is less than 0.295
AND      NOT C is less than 0.575
AND      DO: Conclusion Display

Group_No is 14
IF
AND      Si is less than 0.275
AND      NOT P is less than 0.025
AND      NOT P is less than 0.035
AND      C is less than 0.295
AND      S is less than 0.075
AND      Fe is less than 99.170
AND      NOT Si is less than 0.100
AND      DO: Conclusion Display

OR
AND      NOT Si is less than 0.275
AND      NOT P is less than 0.035
AND      Si is less than 0.410
AND      NOT N is less than 0.500
AND      N is less than 2.000
AND      DO: Conclusion Display

Group_No is 15
IF
AND      NOT Si is less than 0.275
AND      P is less than 0.035
AND      NOT P is less than 0.025
AND      C is less than 0.125
AND      NOT Fe is less than 96.065
AND      DO: Conclusion Display

Group_No is 16
IF
AND      NOT Si is less than 0.275
AND      P is less than 0.035
AND      NOT P is less than 0.025
AND      C is less than 0.125
AND      Fe is less than 96.065
AND      NOT Fe is less than 81.640
AND      DO: Conclusion Display

Group_No is 17
IF
AND      Si is less than 0.275
AND      NOT P is less than 0.025
AND      P is less than 0.035
AND      NOT C is less than 0.385
AND      C is less than 0.485
AND      Pb is less than 0.125
AND      NOT S is less than 0.070
AND      DO: Conclusion Display

OR
AND      Si is less than 0.275
AND      NOT P is less than 0.025
AND      P is less than 0.035
AND      NOT C is less than 0.385
AND      NOT C is less than 0.485
AND      NOT Cr is less than 0.900
AND      NOT Fe is less than 96.925
AND      Fe is less than 97.155
AND      DO: Conclusion Display

Group_No is 18
IF
AND      Si is less than 0.275
AND      NOT P is less than 0.025
AND      P is less than 0.035
AND      C is less than 0.385
AND      C is less than 0.245

```

```

AND      NOT Pb is less than 0.125
AND      DO: Conclusion Display

OR
AND      Si is less than 0.275
AND      NOT P is less than 0.025
AND      P is less than 0.035
AND      C is less than 0.385
AND      NOT C is less than 0.245
AND      NOT Pb is less than 0.125
AND      DO: Conclusion Display

OR
AND      Si is less than 0.275
AND      NOT P is less than 0.025
AND      P is less than 0.035
AND      NOT C is less than 0.385
AND      C is less than 0.485
AND      NOT Pb is less than 0.125
AND      DO: Conclusion Display

OR
AND      Si is less than 0.275
AND      NOT P is less than 0.025
AND      P is less than 0.035
AND      NOT C is less than 0.385
AND      NOT C is less than 0.485
AND      NOT Cr is less than 0.900
AND      Fe is less than 96.925
AND      DO: Conclusion Display

Group_No is 19
IF
AND      Si is less than 0.275
AND      P is less than 0.025
AND      Co is less than 3.500
AND      C is less than 0.725
AND      Ni is less than 8.750
AND      NOT Ni is less than 0.525
AND      NOT Ni is less than 0.575
AND      NOT Mn is less than 0.450
AND      Fe is less than 94.650
AND      DO: Conclusion Display

OR
AND      Si is less than 0.275
AND      P is less than 0.025
AND      Co is less than 3.500
AND      C is less than 0.725
AND      Ni is less than 8.750
AND      NOT Ni is less than 0.525
AND      NOT Ni is less than 0.575
AND      NOT Mn is less than 0.450
AND      NOT Fe is less than 94.650
AND      NOT Fe is less than 97.045
AND      Fe is less than 97.155
AND      DO: Conclusion Display

OR
AND      Si is less than 0.275
AND      NOT P is less than 0.025
AND      P is less than 0.035
AND      C is less than 0.385
AND      C is less than 0.245
AND      Pb is less than 0.125
AND      DO: Conclusion Display

Group_No is 20
IF
AND      Si is less than 0.275
AND      NOT P is less than 0.025
AND      P is less than 0.035
AND      C is less than 0.385
AND      NOT C is less than 0.245
AND      Pb is less than 0.125
AND      DO: Conclusion Display

Group_No is 21
IF
AND      Si is less than 0.275
AND      NOT P is less than 0.025
AND      P is less than 0.035
AND      NOT C is less than 0.385
AND      C is less than 0.485
AND      Pb is less than 0.125
AND      S is less than 0.070
AND      DO: Conclusion Display

```

Group_No is 22

```

IF
  AND Si is less than 0.275
  AND NOT P is less than 0.025
  AND P is less than 0.035
  AND NOT C is less than 0.385
  AND NOT C is less than 0.485
  AND Cr is less than 0.900
  AND DO: Conclusion Display

OR
  AND Si is less than 0.275
  AND NOT P is less than 0.025
  AND P is less than 0.035
  AND NOT C is less than 0.385
  AND NOT C is less than 0.485
  AND NOT Cr is less than 0.900
  AND NOT Fe is less than 96.925
  AND NOT Fe is less than 97.155
  AND DO: Conclusion Display

OR
  AND NOT Si is less than 0.275
  AND P is less than 0.035
  AND NOT P is less than 0.025
  AND NOT C is less than 0.125
  AND NOT C is less than 0.445
  AND DO: Conclusion Display

```

Group_No is 23

```

IF
  AND Si is less than 0.275
  AND P is less than 0.025
  AND Co is less than 3.500
  AND NOT C is less than 0.725
  AND NOT Fe is less than 85.450
  AND NOT Cr is less than 0.250
  AND C is less than 1.050
  AND Mn is less than 0.500
  AND Cr is less than 4.550
  AND C is less than 0.900
  AND Fe is less than 93.925
  AND DO: Conclusion Display

OR
  AND Si is less than 0.275
  AND P is less than 0.025
  AND Co is less than 3.500
  AND NOT C is less than 0.725
  AND NOT Fe is less than 85.450
  AND NOT Cr is less than 0.250
  AND C is less than 1.050
  AND Mn is less than 0.500
  AND Cr is less than 4.550
  AND NOT C is less than 0.900
  AND DO: Conclusion Display

```

Group_No is 24

```

IF
  AND Si is less than 0.275
  AND P is less than 0.025
  AND Co is less than 3.500
  AND C is less than 0.725
  AND Ni is less than 8.750
  AND NOT Ni is less than 0.525
  AND Ni is less than 0.575
  AND DO: Conclusion Display

OR
  AND NOT Si is less than 0.275
  AND P is less than 0.035
  AND P is less than 0.025
  AND V is less than 0.010
  AND Si is less than 0.325
  AND NOT Mn is less than 0.625
  AND Fe is less than 95.950
  AND DO: Conclusion Display

OR
  AND NOT Si is less than 0.275
  AND P is less than 0.035
  AND P is less than 0.025
  AND NOT V is less than 0.010
  AND C is less than 0.525
  AND NOT Fe is less than 90.245
  AND DO: Conclusion Display

```

Group_No is 25

```
IF      Si is less than 0.275
AND     P is less than 0.025
AND     NOT Co is less than 3.500
AND     Cr is less than 1.500
AND     NOT Fe is less than 77.010
AND     Fe is less than 85.600
AND     DO: Conclusion Display

Group_No is 26
IF      Si is less than 0.275
AND     P is less than 0.025
AND     NOT Co is less than 3.500
AND     Cr is less than 1.500
AND     NOT Fe is less than 77.010
AND     NOT Fe is less than 85.600
AND     DO: Conclusion Display

Group_No is 27
IF      Si is less than 0.275
AND     P is less than 0.025
AND     Co is less than 3.500
AND     C is less than 0.725
AND     NOT Ni is less than 8.750
AND     DO: Conclusion Display

Group_No is 28
IF      Si is less than 0.275
AND     P is less than 0.025
AND     NOT Co is less than 3.500
AND     Cr is less than 1.500
AND     Fe is less than 77.010
AND     DO: Conclusion Display
```

Appendix D

Multiple regression techniques

The large amounts of example cutting data available lend themselves to statistical analysis to produce a mathematical model of how the dependent variables, such as cutting velocity and feed, are related to the independent variables, such as surface hardness. One of the simplest forms of analysis is the use of linear and multiple regression methods to fit a polynomial function to the sample data. The polynomial is of the form:

$$Y = \beta_0 X + \beta_1 X^2 + \beta_2 X^3 + \dots + \beta_n X^n + \varepsilon \quad (\text{D.1})$$

As the order of the polynomial function increases it is necessary to have a larger number of unique data points to solve for the constant coefficients β_i . Thus the order of the polynomial considered will depend on several factors:

1. The perceived pattern of the data. Possibly the most effective way of finding the best polynomial to fit to a given set of data is the "eyeball" method.
2. The number of different values of the independent variable. For instance, if the data for a material group only contains two different values of hardness, it is impossible to fit a second order polynomial (quadratic) to the data.
3. The uniformity of the data. The data must be sufficiently uniform for a simple polynomial fit to be valid. This is related to the "eyeball" technique and may be quantified by calculating the sum of squares of the residuals or the fitting factor, R^2 .

Notation

To simplify the presentation of these regression solutions, some common functions and combinations of variables are defined as follows:

For a set of example data points of the form (x,y) :

$$\begin{aligned}
 a &= \sum x & b &= \sum x^2 & c &= \sum x^3 \\
 d &= \sum x^4 & e &= \sum x^5 & f &= \sum x^6 \\
 t &= \sum y & u &= \sum xy & v &= \sum x^2y & w &= \sum x^3y \\
 n &= \text{number of example points} \\
 h &= (at - nu) & i &= (bu - av) & j &= (cv - bw) \\
 k &= (a^2 - bn) & l &= (ab - cn) & m &= (ac - dn) \\
 z &= (b^2 - ac) & o &= (bc - ad) & p &= (bd - ae) \\
 q &= (c^2 - bd) & r &= (cd - be) & s &= (ce - bf)
 \end{aligned}$$

Linear regression

Linear regression involves fitting an equation of the order 1 to the observed data points. Graphically, this represents drawing a least squares best fit straight line through the points. If the least squares fit is represented by the following equation:

$$y = \beta_0 + \beta_1 x + \varepsilon \quad (\text{D.2})$$

then the least squares solution for β_0 and β_1 is given by:

$$\begin{aligned}
 \beta_1 &= \frac{n \sum XY - \sum X \sum Y}{n \sum X^2 - (\sum X)^2} \\
 &= \frac{nu - at}{nb - a^2}
 \end{aligned} \quad (\text{D.3})$$

$$\begin{aligned}
 \beta_0 &= \frac{\sum Y - \beta_1 \sum X}{n} \\
 &= \frac{t - \beta_1 a}{n}
 \end{aligned} \quad (\text{D.4})$$

Multiple regression

If a higher order fit is required or there are more than one independent variables then the multiple regression technique is applicable. This may be thought of as several linear regression calculations performed in sequence on each independent variable whilst keeping all the other variables constant.

Second order polynomial (quadratic) curve fitting

The simplest example involves two independent variables. If these variables are set to be x and x^2 then a polynomial function of the following form may be fitted to the example data:

$$y = \beta_0 + \beta_1 x + \beta_2 x^2 + \varepsilon \quad (\text{D.5})$$

Using calculus, the least squares situation produces the following equations :

$$\begin{aligned} t &= n\beta_0 + a\beta_1 + b\beta_2 \\ u &= a\beta_0 + b\beta_1 + c\beta_2 \\ v &= b\beta_0 + c\beta_1 + d\beta_2 \end{aligned} \quad (\text{D.6})$$

Equations D.6 may be solved for β_n to give:

$$\beta_0 = \frac{(uc - vb)(b^2 - ac) + (ua - bt)(c^2 - bd)}{(a^2 - bn)(c^2 - bd) - (b^2 - ac)^2} \quad (\text{D.7})$$

$$\beta_1 = \frac{(av - ub)(cn - ab) + (at - un)(ad - bc)}{(a^2 - bn)(ad - bc) - (ac - b^2)(cn - ab)} \quad (\text{D.8})$$

$$\beta_2 = \frac{(ub - av)(a^2 - bn) - (ta - un)(b^2 - ac)}{(cn - ab)(b^2 - ac) - (ad - bc)(a^2 - bn)} \quad (\text{D.9})$$

Third order polynomial (cubic) curve fitting

In order to fit a polynomial of order 3, it is necessary to solve for β_n in the equation:

$$y = \beta_0 + \beta_1x + \beta_2x^2 + \beta_3x^3 \quad (\text{D.10})$$

The least squares solution gives the following four simultaneous equations:

$$\begin{aligned} \sum y &= n\beta_0 + (\sum x)\beta_1 + (\sum x^2)\beta_2 + (\sum x^3)\beta_3 \\ \sum xy &= (\sum x)\beta_0 + (\sum x^2)\beta_1 + (\sum x^3)\beta_2 + (\sum x^4)\beta_3 \\ \sum x^2y &= (\sum x^2)\beta_0 + (\sum x^3)\beta_1 + (\sum x^4)\beta_2 + (\sum x^5)\beta_3 \\ \sum x^3y &= (\sum x^3)\beta_0 + (\sum x^4)\beta_1 + (\sum x^5)\beta_2 + (\sum x^6)\beta_3 \end{aligned} \quad (\text{D.11})$$

Equations D.11 may be solved to give:

$$\beta_3 = \frac{(iq - jz)(lz - ko) + (ik - hz)(oq - rz)}{(kp - mz)(oq - rz) + (pq - sz)(lz - ko)} \quad (\text{D.12})$$

$$\beta_2 = \frac{(iq - jz) + (sz - pq)\beta_3}{(oq - rz)} \quad (\text{D.13})$$

$$\beta_1 = \frac{h - l\beta_2 - m\beta_3}{k} \quad (\text{D.14})$$

$$\beta_0 = \frac{u - b\beta_1 - c\beta_2 - d\beta_3}{a} \quad (\text{D.15})$$

Appendix E

Cutting data regression curves

This appendix presents a small selection of the regression curve equations generated by the machinability assessment module. Each set of curves is specific to a machinability group. The two types of curves shown are for cutting velocity against material hardness and feed per tooth against material hardness. Each graph features three data series representing roughing, semi-roughing and finishing cuts. The cutting velocity data is approximated with respect to material hardness by second order polynomials. The feed per tooth data is approximated with respect to material hardness by third order polynomials. All hardness values are taken as the minimum hardness for each item of cutting data.

The machinability groups considered are:

Group 17: Free machining alloy steels, wrought (medium carbon resulfurized)

Group 18: Free machining alloy steels, wrought (medium and high carbon leaded)

Group 54: Free machining stainless steels, wrought (martensitic)

Group 66: Alloy steels, cast (medium carbon)

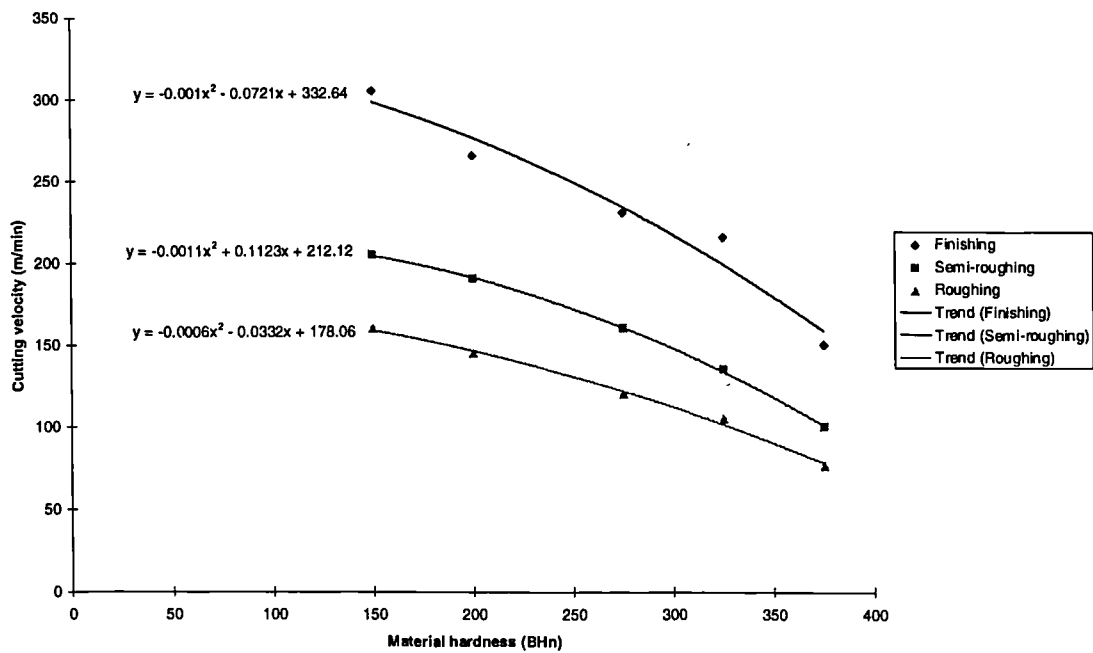

Figure E.1: Regression curves of cutting velocity against material hardness for free machining alloy steels, wrought (medium carbon resulfurized)

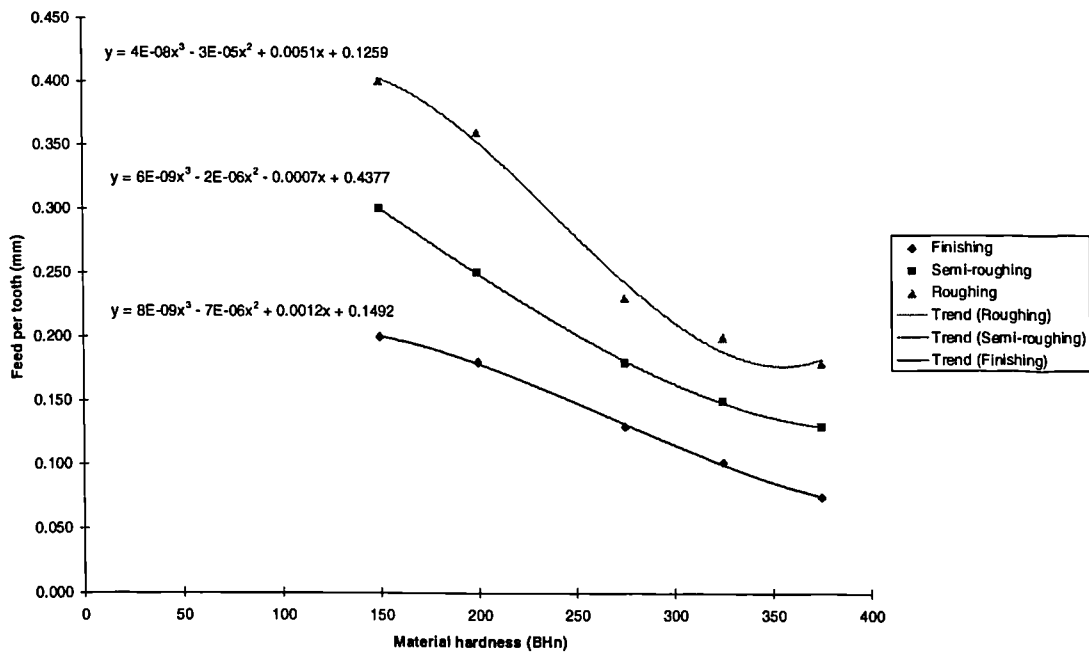

Figure E.2: Regression curves of fed per tooth against material hardness for free machining alloy steels, wrought (medium carbon resulfurized)

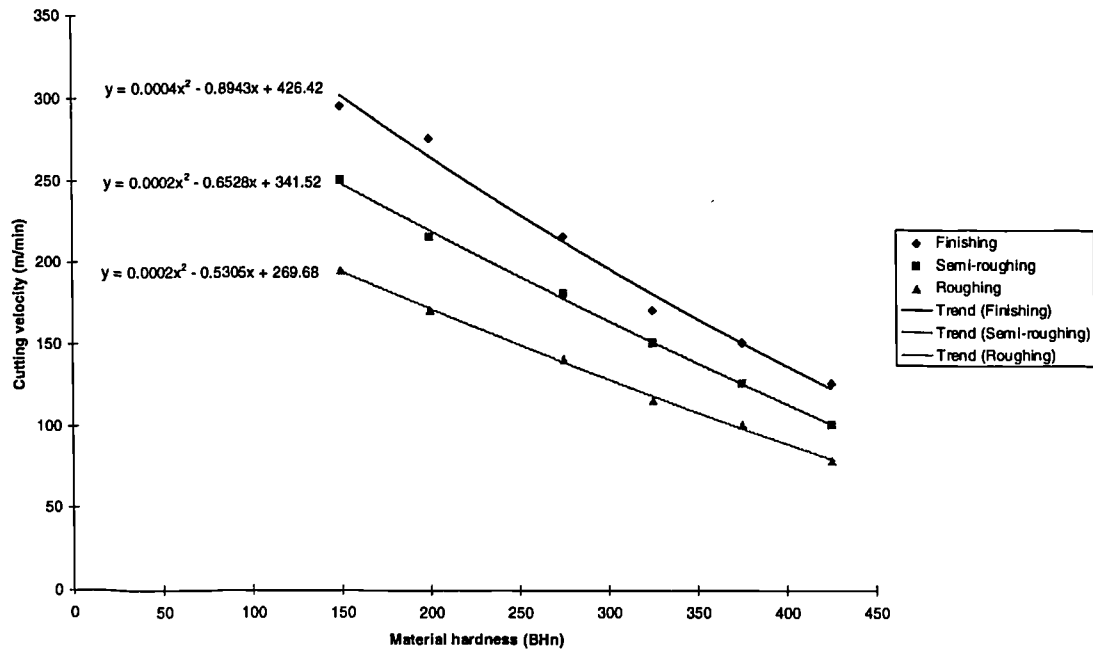

Figure E.3: Regression curves of cutting velocity against material hardness for free machining alloy steels, wrought (medium and high carbon leaded)

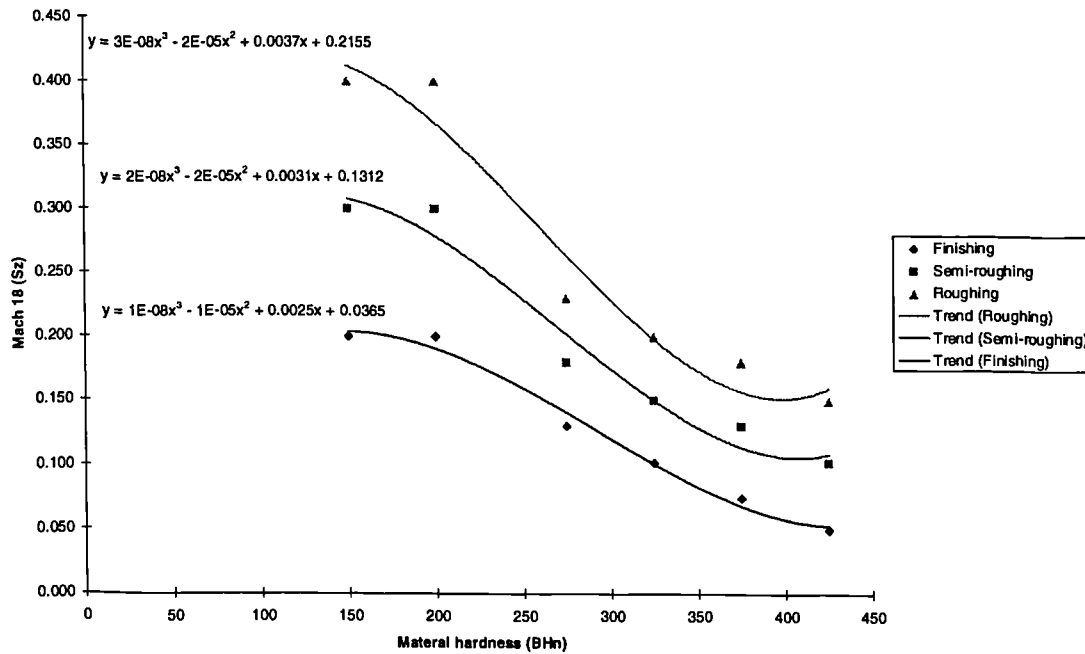

Figure E.4: Regression curves of feed per tooth against material hardness for free machining alloy steels, wrought (medium and high carbon leaded)

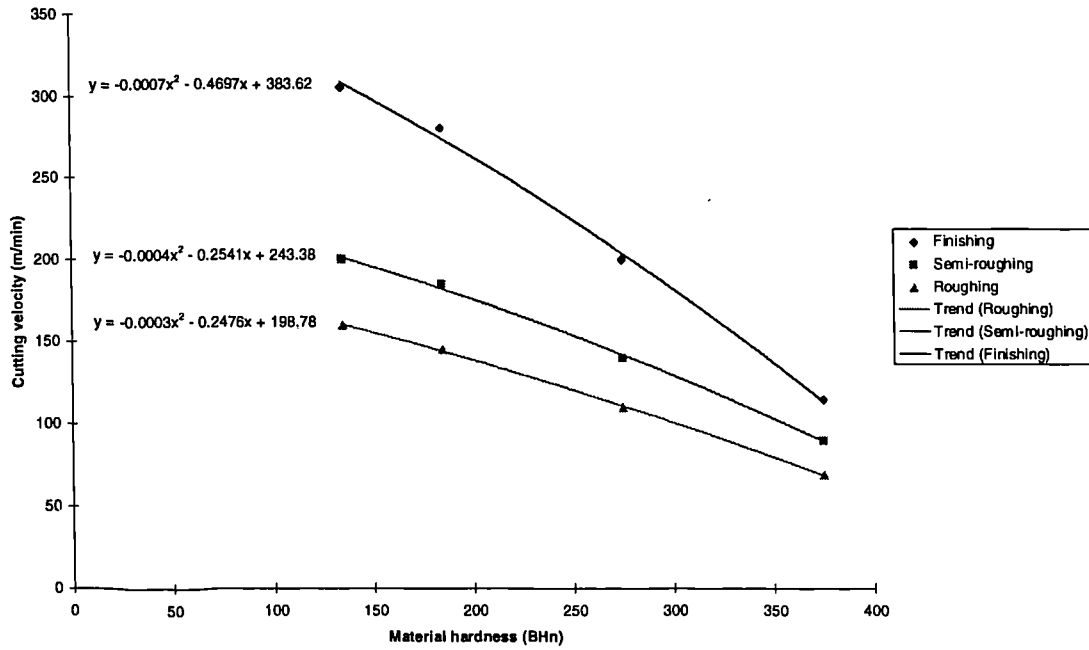

Figure E.5: Regression curves of cutting velocity against material hardness for free machining stainless steels, wrought (martensitic)

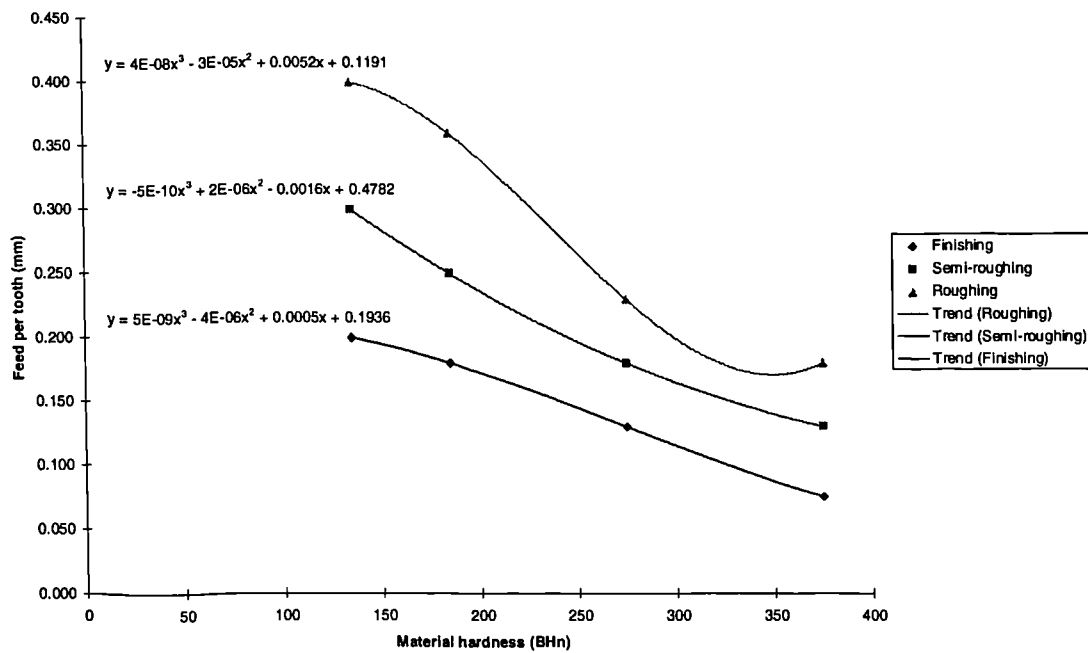

Figure E.6: Regression curves of feed per tooth against material hardness for free machining stainless steels, wrought (martensitic)

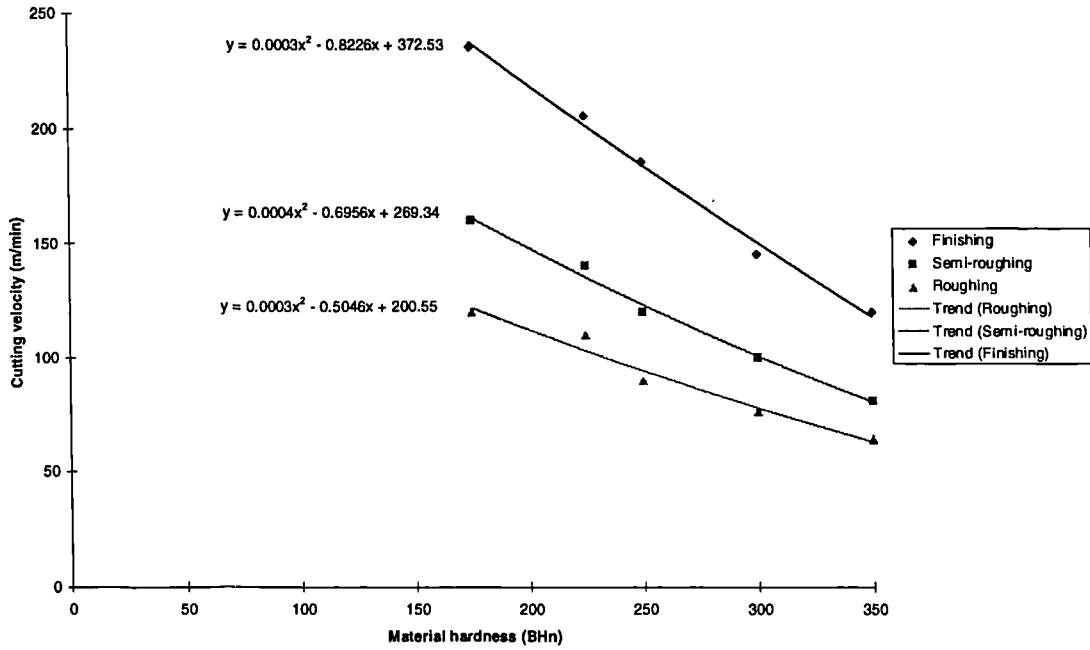

Figure E.7: Regression curves of cutting velocity against material hardness for alloy steels, cast (medium carbon)

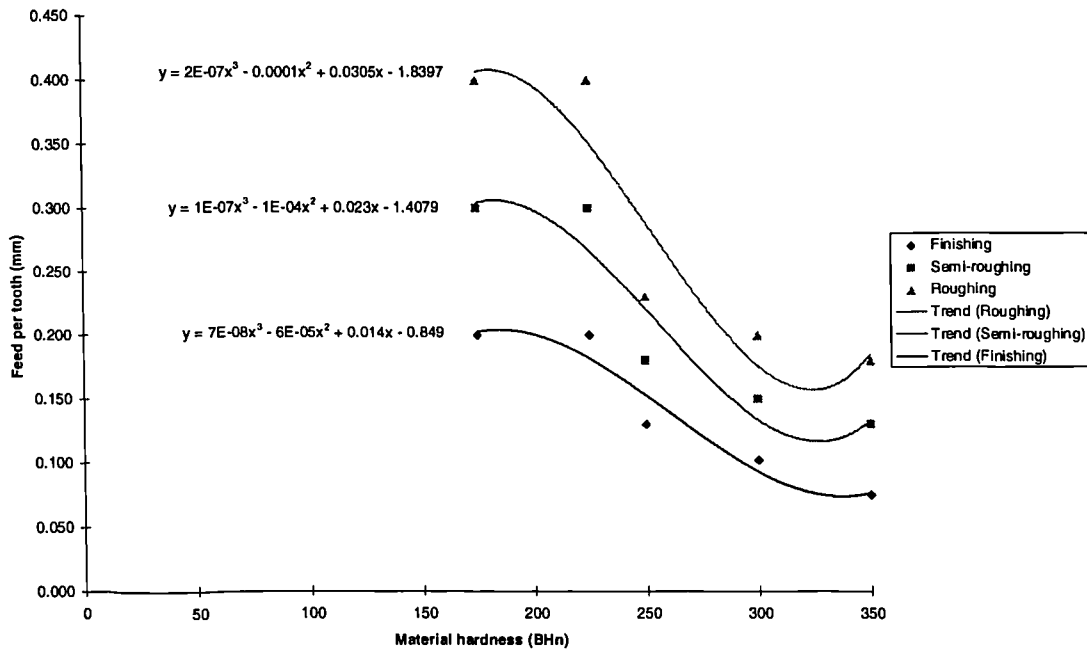

Figure E.8: Regression curves of feed per tooth against material hardness for alloy steels, cast (medium carbon)

Appendix F

ISO classification system for cemented carbide tools

Cemented carbides (sometimes called cermets) are lattices of hard transition metal carbides held within a softer binding metal matrix. They are manufactured by powder metallurgical processes consisting of production of the carbide particles followed by compaction and sintering at high temperature. Most modern cemented carbides feature hard tungsten carbide (WC) particles and cobalt as the binder metal.

Cemented carbides have been classified by the International Organisation for Standardization in ISO 513 : 1991 *Application of hard cutting materials for machining by chip removal - Designation of the main groups of chip removal and groups of application*. This is identical to the British Standard BS 7662 : 1993.

The carbides are classified on the basis of the material to be machined. A summary of this classification system is given in Table F.1. Cutting speed and wear resistance increase from the bottom to the top of the classification whilst toughness and feed rate increase from the top to the bottom of the table.

Although it is not possible to directly relate an specific insert grade to a corresponding single ISO carbide designation, most tool manufacturers do provide ISO application ranges for their insert grades. The ISO application ranges of the currently available insert grades from Seco Tools are summarized in Table F.2.

Main machining group	Application group	Operation and working conditions
P: steel, cast steel.	P01	High precision turning and boring, high cutting speeds, small chip cross-section, dimensional accuracy, good surface finish, and vibration-free machining.
	P10/20	Turning, copy turning, thread cutting and milling, high cutting speeds, and small to medium chip cross-section.
	P30	Turning milling, planing, medium to low cutting speeds, medium to large chip cross-section, also under favourable conditions.
	P40	Turning, planing, milling, shaping, low cutting speeds, large chip cross-section, high rake angles, unfavourable conditions; also automatic turning.
	P50	Where highest demands are made on toughness of carbide: turning, planing and shaping, low cutting speeds, large chip cross-section, and high rakes under unfavourable conditions. Automatic turning.
M: steel, cast steel, austenitic manganese steel, cast-iron alloys, austenitic steels, malleable and spheroidal cast iron, free cutting mild steel.	M10	Turning, medium to high cutting speeds, small to medium chip cross-section.
	M20	Turning, milling, medium cutting speeds, and medium chip cross-section.
	M30	Turning, milling, planing, medium cutting speeds, medium to large cross-section.
	M40	Turning, form turning, parting off and recessing, particularly for automatics.
K: cast iron, chilled cast iron, hardened steel, non-ferrous metals, non-metallic materials.	K01	Turning precision turning and precision boring, finish milling, and scraping.
	K10	Turning, milling, boring, countersinking, reaming, scraping and broaching.
	K20	Turning, milling, planing, countersinking, reaming, scraping and broaching under tougher conditions than K10.
	K30	Turning, milling, planing, shaping under unfavourable conditions, high rakes.
	K40	Turning, milling, planing, shaping under unfavourable conditions, high rakes.

Table F.1: ISO classification of cemented carbides

Grade	Description	ISO P	ISO M	ISO K
T10M	Grade for fine to medium machining of cast iron without cutting fluid. Extremely wear resistant grade for high cutting speeds.	-	-	5
T15M	Basic grade for fine to heavy machining of grey cast iron and nodular cast iron with or without cutting fluid.	-	-	1-24
T20M	Wear resistant grade for fine to medium machining at high cutting speed in steel, and for milling in hardened steel. Complementary grade to T25M in milling of stainless steel at high cutting speed. Usable in roughing of grey cast iron and nodular cast iron.	8-30	15-25	20-35
T25M	Very tough grade for medium machining to roughing of steel. Basic grade for milling in austenitic stainless steel. Excellent grade for machining under unstable conditions.	15-45	20-40	30-40
T60M	PVD-coated grade for milling with Minimaster. Good combination of wear resistance and toughness.	28	-1	-1
CP30	Wear resistant grade for slotting, and cutting-off. Complementary grade to T25M at high cutting speeds in steel. Usable in hardened steel.	15-30	-	-
CP50	Universal grade for thread milling. Very tough PVD-coated micrograin grade with good edge sharpness.	20-30	15-30	20-30
C15M	Carbonitride-based cermet for fine to medium machining of steel, and for fine machining of austenitic stainless steel. First choice for operations where the demands for surface finish are high.	5-25	10-25	-
S10M	Wear resistant grade for fine to medium machining within the ISO P and ISO M area. Excellent complement to T20M in hard steel. Performs well with coolant.	10-25	15-25	-
S25M	Universal grade for steel milling with a very broad application area. Performs very well with coolant. Excellent grade for milling when the demands for toughness, wear resistance, and resistance to comb cracking are high.	20-40	18-31	-
S4	Grade for heavy-duty machining.	25-35	24-28	-
S60M	Tough grade for roughing under adverse conditions. Suitable for high feeds and large depths of cut. Performs very well with coolant. Very suitable for machining conditions involving casting skin and sand inclusions.	28-45	29-35	-
HX	Basic grade for milling in cast iron and non-ferrous metals. Fine grained grade with very high hardness and high toughness. Usable with cutting fluids.	-	18-22	15-25

Table F.2: ISO application ranges for Seco insert grades

Appendix G

Derivation of tool life objective functions

In order to optimize cutting conditions for milling operations there must be a clearly defined objective upon which mathematical methods can be applied to produce a solution. The most common objective functions are minimum cost and maximum production rate. The following derivations show how these objectives may be expressed as functions of tool life with respect to cutting velocity.

Minimum cost

Tool life is given by the extended Taylor's equation:

$$T = \frac{2\pi}{\phi_s} \frac{C_1}{v^\alpha s_{eq}^\beta a^\gamma} = \frac{C_a}{v^\alpha} \quad (G.1)$$

where C_a is a constant with respect to cutting velocity (v).

Cutting time per component is given by:

$$\begin{aligned} t_2 &= \frac{L_{total}}{s_{table}} \\ &= \frac{L_{total}}{s_2 n_i n} \\ &= \frac{L_{total} \pi D}{1000 v s_2 n_i} \end{aligned}$$

and,

$$t_2 = \frac{C_b}{v} \quad (G.2)$$

where C_b is a constant with respect to cutting velocity (v).

Total cost per component is given by the following equation:

$$c_{total} = (xt_1) + (xt_2) + \left(\frac{xt_2 n_i t_3}{T_{exp}} \right) + \left(\frac{yt_2}{T_{exp}} \right) \quad (G.3)$$

Substituting equations G.1 and G.2 into equation G.3 gives:

$$c_{total} = xt_1 + \frac{x C_b}{v} + \frac{C_b}{C_a} v^{(\alpha-1)} (xt_3 n_i + y) \quad (G.4)$$

As long as α is greater than 1, equation G.4 can be partially differentiated with respect to v and set to zero:

$$\begin{aligned} \frac{\partial C_t}{\partial v} &= -\frac{x C_b}{v^2} + \frac{C_b}{C_a} (xt_3 n_i + y) (\alpha - 1) v^{(\alpha-2)} \\ &= 0 \quad \text{for minimum cost} \end{aligned} \quad (G.5)$$

Thus the optimum cutting velocity for minimum cost (v_{oc}) is given by:

$$v_{oc} = \left[\frac{x C_a}{(xt_3 n_i + y) (\alpha - 1)} \right]^{\frac{1}{\alpha}} \quad (G.6)$$

and the corresponding tool life for minimum cost (T_{oc}) is given by:

$$T_{oc} = \frac{C_a}{v_{oc}^\alpha} = (\alpha - 1) \frac{(xt_3 n_i + y)}{x} \quad (G.7)$$

Maximum production rate

Maximum production rate is generally equivalent to minimum production time per component. The total time taken to produce one component is given by:

$$t_{total} = t_1 + t_2 + n_i t_3 \left(\frac{t_2}{T} \right) \quad (G.8)$$

Substituting equations G.1 and G.2 into equation G.8 gives:

$$t_{total} = t_1 + \frac{C_b}{v} + \frac{C_b}{C_a} t_3 n_i (\alpha - 1) v^{(\alpha-1)} \quad (G.9)$$

As long as α is greater than 1, equation G.9 can be partially differentiated with respect to v and set to zero:

$$\begin{aligned} \frac{\partial t_{total}}{\partial v} &= -\frac{C_b}{v^2} + \frac{C_b}{C_a} t_3 n_i (\alpha - 1) v^{(\alpha-2)} \\ &= 0 \quad \text{for minimum production time} \end{aligned} \quad (G.10)$$

Thus the optimum cutting velocity for maximum production rate (v_{ot}) is given by:

$$v_{ot} = \left[\frac{C_a}{n_i t_3 (\alpha - 1)} \right]^{\frac{1}{\alpha}} \quad (G.11)$$

and the corresponding tool life for maximum production rate (T_{ot}) is given by:

$$T_{ot} = \frac{C_a}{v_{ot}^\alpha} = (\alpha - 1) n_i t_3 \quad (G.12)$$

Appendix H

Calculation of engagement angle

If the eccentricity of the milling cutter from the centre of the area to be machined is known then the engagement angle can be calculated as follows:

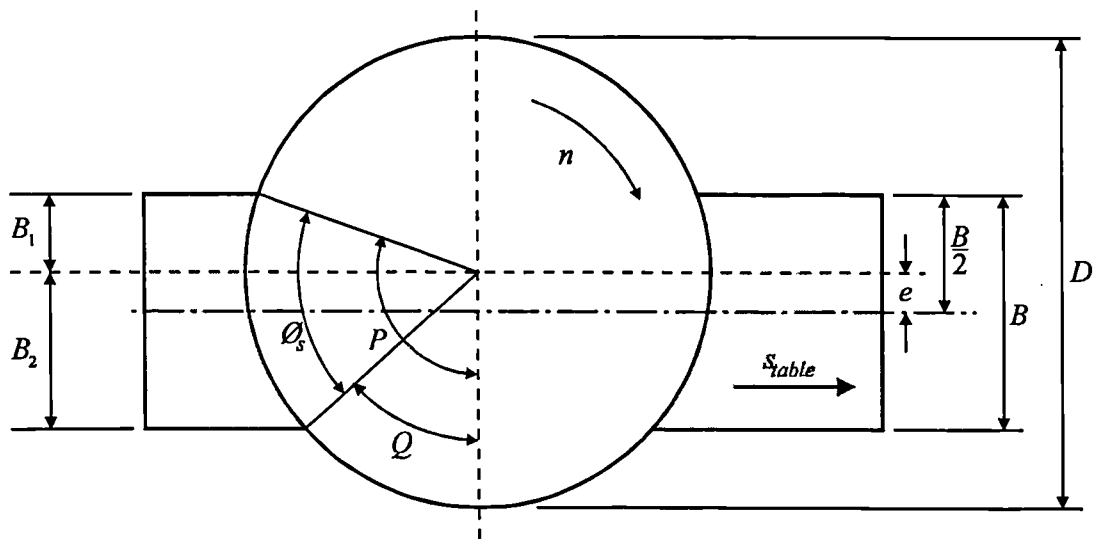

Figure H.1: Engagement angle of a milling cutter

From Figure H.1 it can be seen that:

$$B_1 = \frac{B}{2} - e \quad (H.1)$$

$$B_1 = \frac{B - 2e}{2}$$

and similarly:

$$B_2 = \frac{B}{2} + e \quad (H.2)$$

$$= \frac{B + 2e}{2}$$

For the angle P :

$$\begin{aligned}\cos(P) &= \frac{-2B_1}{D} \\ &= \frac{(2e - B)}{D}\end{aligned}\quad (\text{H.3})$$

and similarly for the angle Q :

$$\begin{aligned}\cos(Q) &= \frac{2B_2}{D} \\ &= \frac{(B + 2e)}{D}\end{aligned}\quad (\text{H.4})$$

The engagement angle ϕ_s is the difference between the angles P and Q :

$$\phi_s = P - Q \quad (\text{H.5})$$

Substituting equations H.3 and H.4 into equation H.5 gives:

$$\phi_s = \cos^{-1}\left(\frac{2e - B}{D}\right) - \cos^{-1}\left(\frac{B + 2e}{D}\right) \quad (\text{H.6})$$

Appendix I

Cutter geometry definition

The basic geometry of the cutting edge of an straight sided insert mounted on a cutter is shown in Figure I.1.

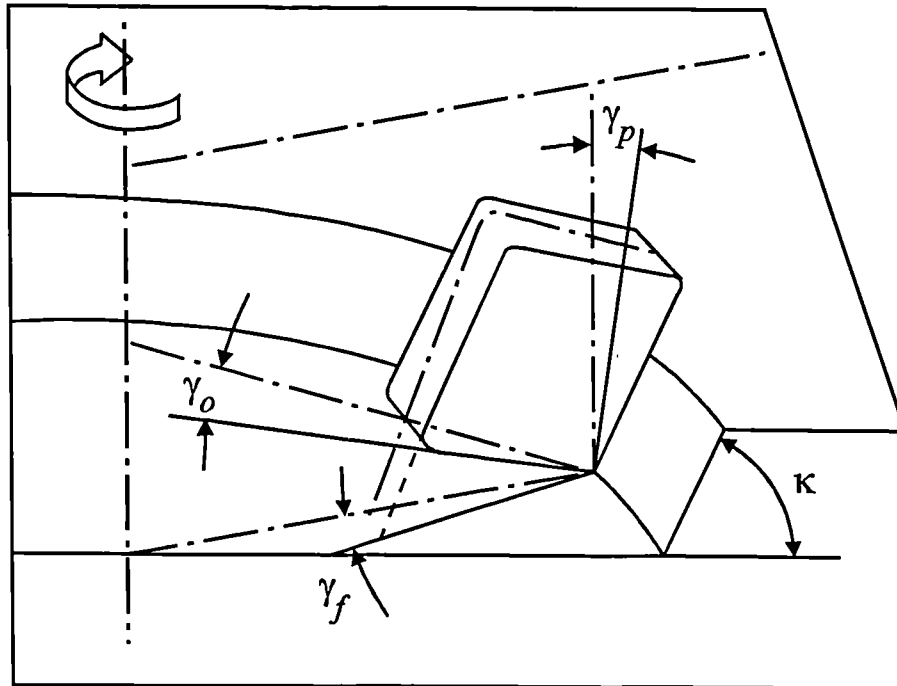

Figure I.1: Geometry of cutting edge (after Seco Tools AB, 1994)

where γ_f is the tool radial rake angle ($^\circ$), γ_o is the tool orthogonal rake angle ($^\circ$), γ_p is the tool axial rake angle ($^\circ$) and κ is the cutter approach angle ($^\circ$)

The axial and radial rake angles are important in defining the chip evacuation process and the direction of the cutting forces. They also define to a large extent the effective mechanical strength of the cutting edge. Axial and radial rake angles can be positive or negative and the three most common configurations of these angles are shown in Figure I.2.

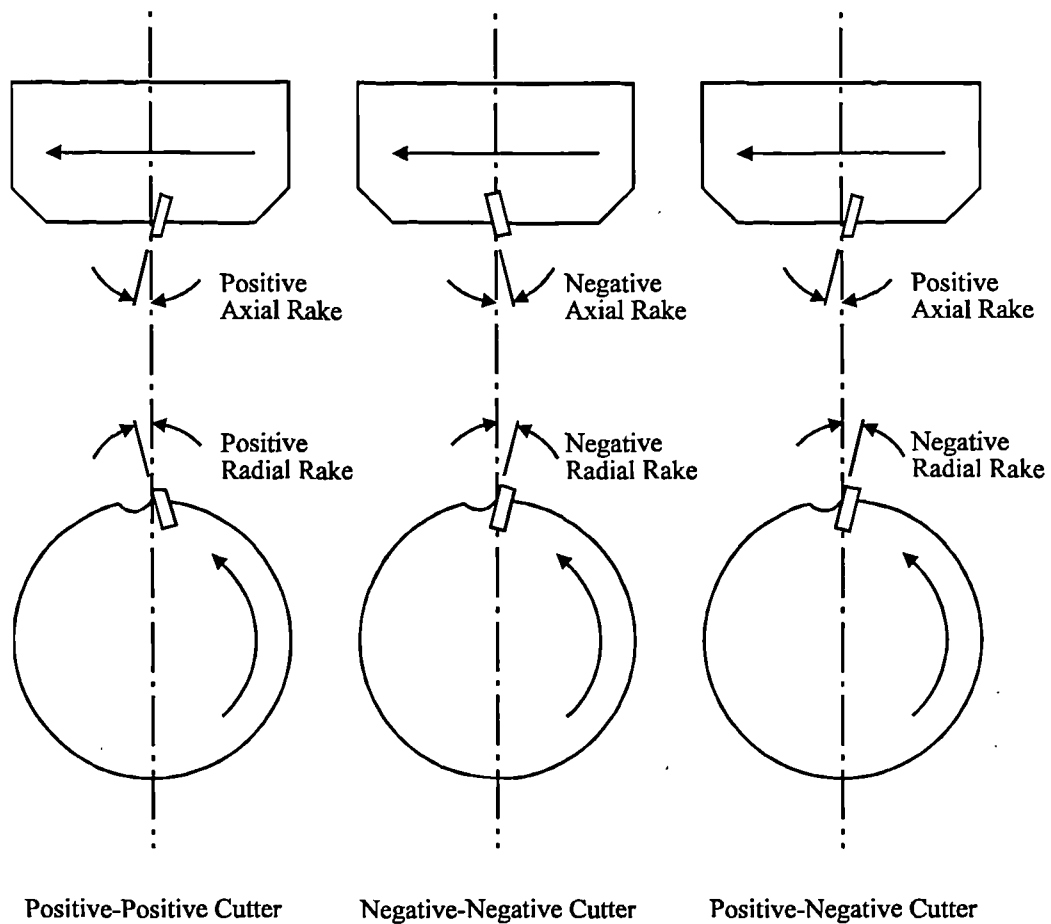

Figure I.2: Common cutter rake angle configurations

A negative-negative cutter offers the strongest cutting edge and has the advantage that double-sided square inserts can be used, thus providing eight strong and relatively inexpensive cutting edges per insert. As the chip tends to be bent downwards, towards the workpiece, there may be problems of chip welding or poor chip evacuation and this geometry is not generally recommended for long chipping materials. This geometry is commonly used for hard materials where heavy impact forces are anticipated. A positive-positive cutter geometry can only be used with single sided inserts. It produces a light cutting action and a chip forming mechanism that is favourable for steel. A positive-negative cutter will form helical chips that tend to spiral out of the chip pocket. This makes it particularly suitable for slotting and other closed or semi-closed operations where efficient chip evacuation is required.

