

Durham E-Theses

A Comparison of Stave Churches and Pre-Christian Cult-Houses, Their Origins and Influences

LYLE TOMPSEN

How to cite:

TOMPSEN, LYLE (2020) A Comparison of Stave Churches and Pre-Christian Cult-Houses, Their Origins and Influences. Doctoral thesis, Durham University.

Use policy

The full-text may be used and/or reproduced, and given to third parties in any format or medium, without prior permission or charge, for personal research or study, educational, or not-for-profit purposes provided that:

- a full bibliographic reference is made to the original source
- a <https://etheses.durham.ac.uk/id/eprint/13505/> is made to the metadata record in Durham E-Theses
- the full-text is not changed in any way

The full-text must not be sold in any format or medium without the formal permission of the copyright holders.

Please consult the [full Durham E-Theses policy](#) for further details.



Fig. 40 Bulbous base from Haltdalen Stave Church. The image on the left is from Haltdalen Stave Church. The right hand image is a bell shaped base from Nidaros Cathedral. It is firmly dated to c. 1090-1120 (Photo source of Nidaros architectural remant from Blindheim 1966: Plate 11).

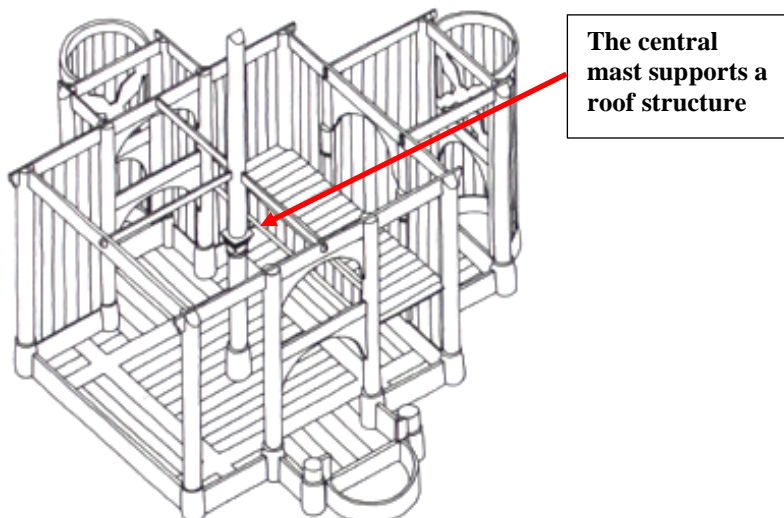

Fig. 41 Mast church reconstruction. This isometric of a Mast Church is based on an original drawing by Håkon Christie in 1969. Secondary source: Ankar and Havran 2005: 192 . Used with permission from the Directorate for Cultural Heritage. Mast churches are detailed in Section: Stave Church Styles.

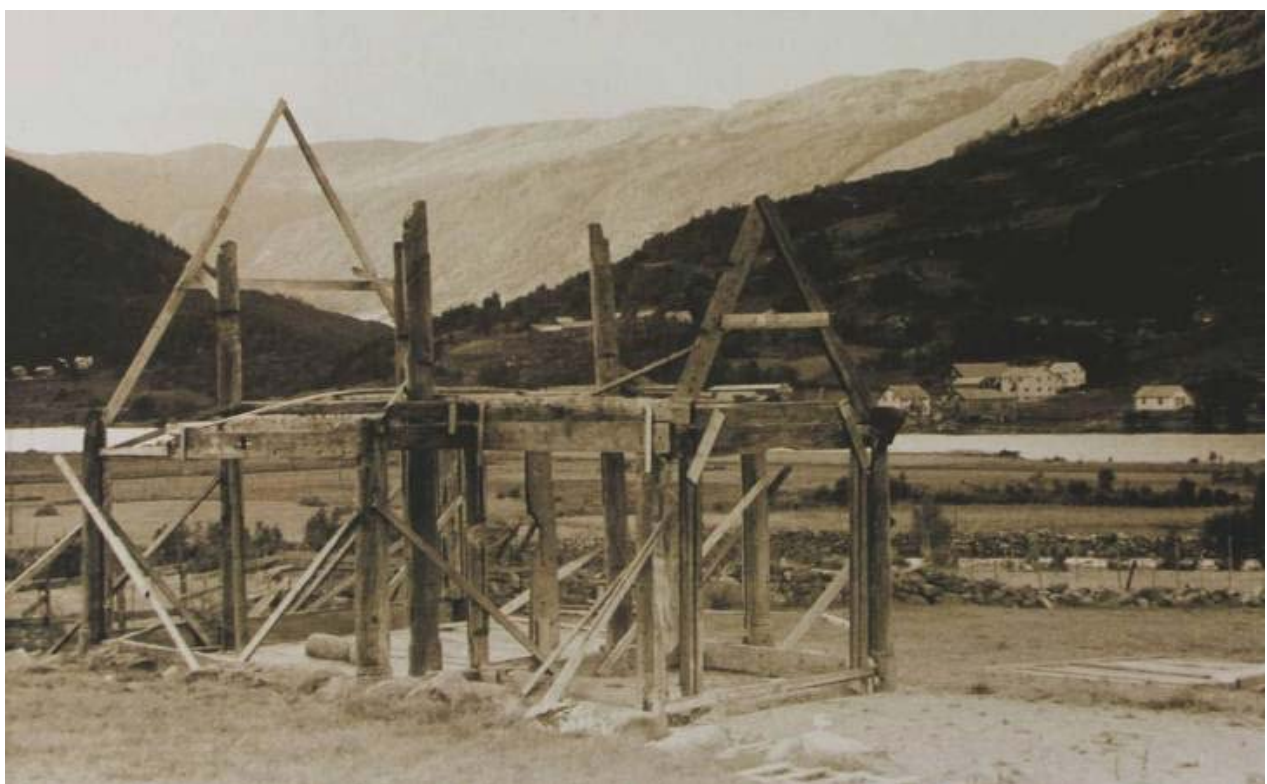
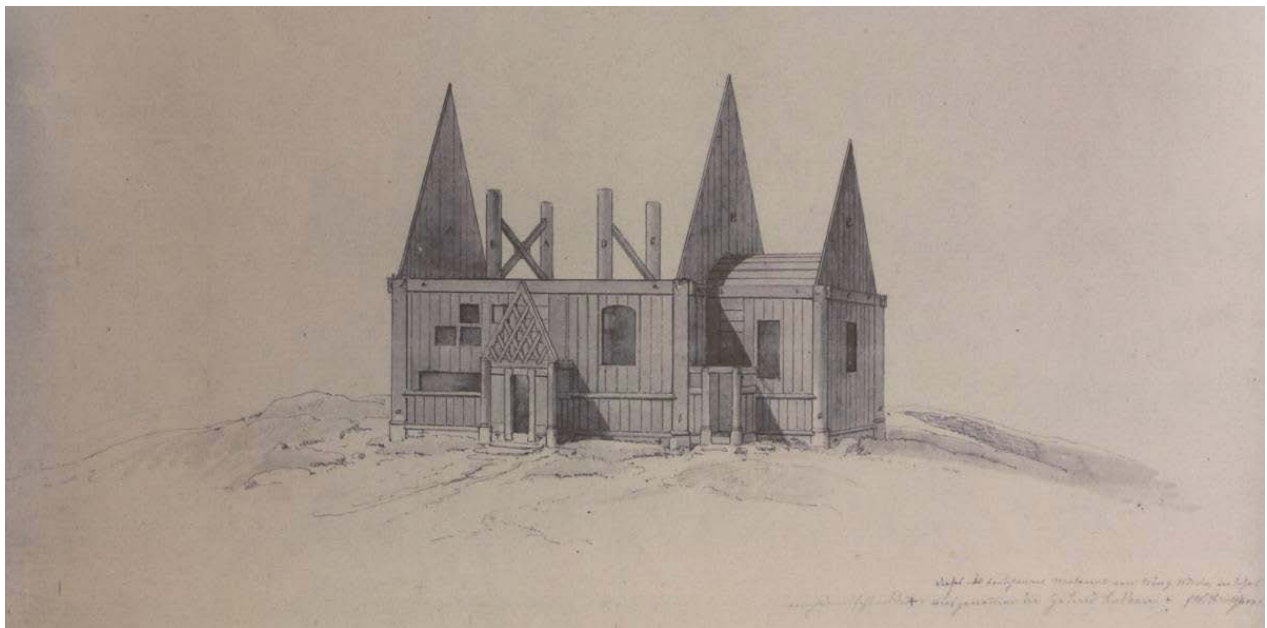

Fig. 42 Vang and Oye Stave Church. The top image is Vang Church in 1841. When parts were crated and sent to Poland for reconstruction, the entire roof structure is missing (drawing by Franz Wilhelm Schiertz). The bottom photo is Øye Stave Church during reconstruction. These are all that remained of the original structure. Both images used with permission from Riksantikvaren, Directorate for Cultural Heritage.



Fig. 43 Kvernes Stave Church reconstruction from 1633. Source: Valebrokk and Thiis-Evensen 2001: 82.

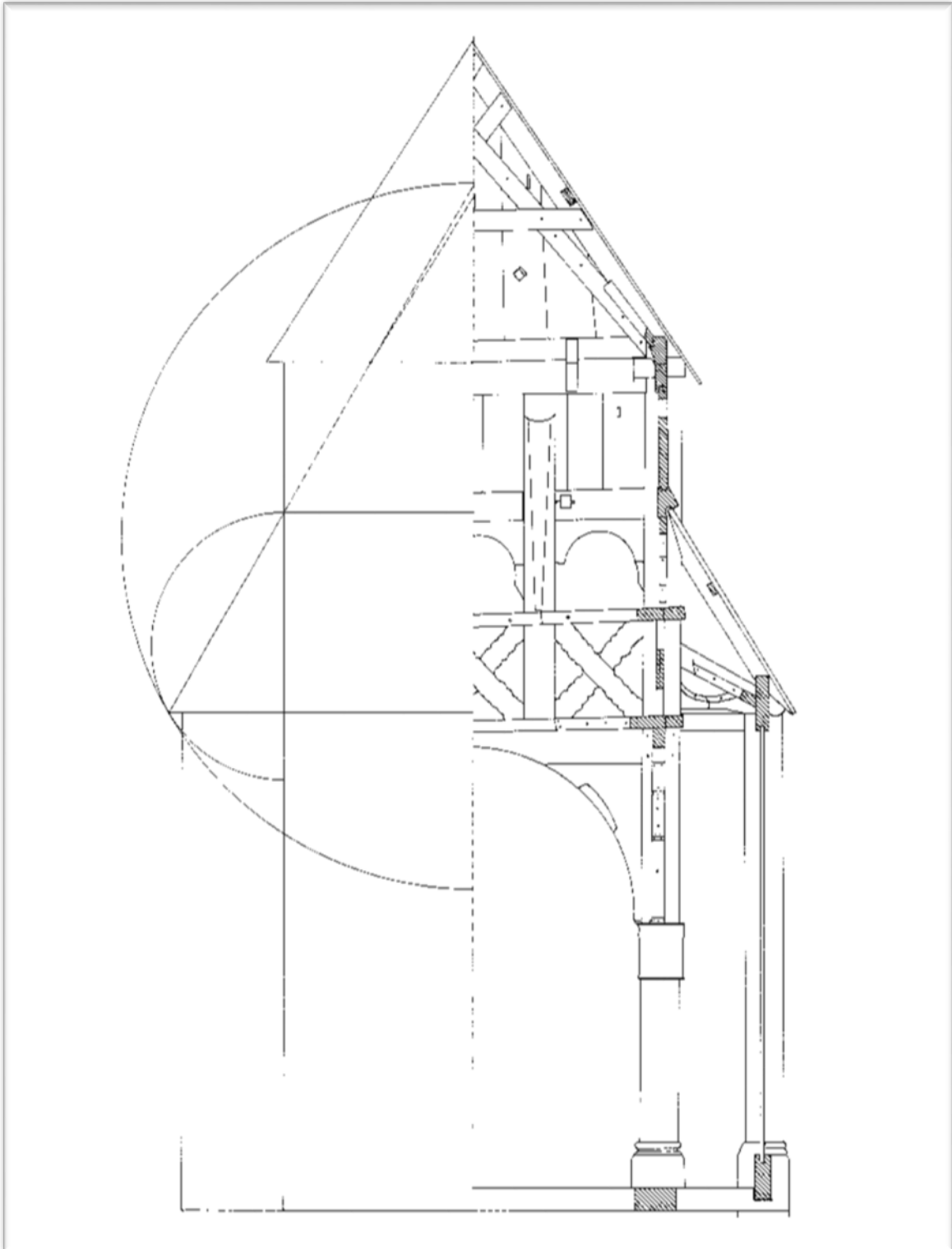

Fig. 44 Lomen Stave Church and its underlying geometric planning principles. Source: Jensenius 1988: Frontspiece.

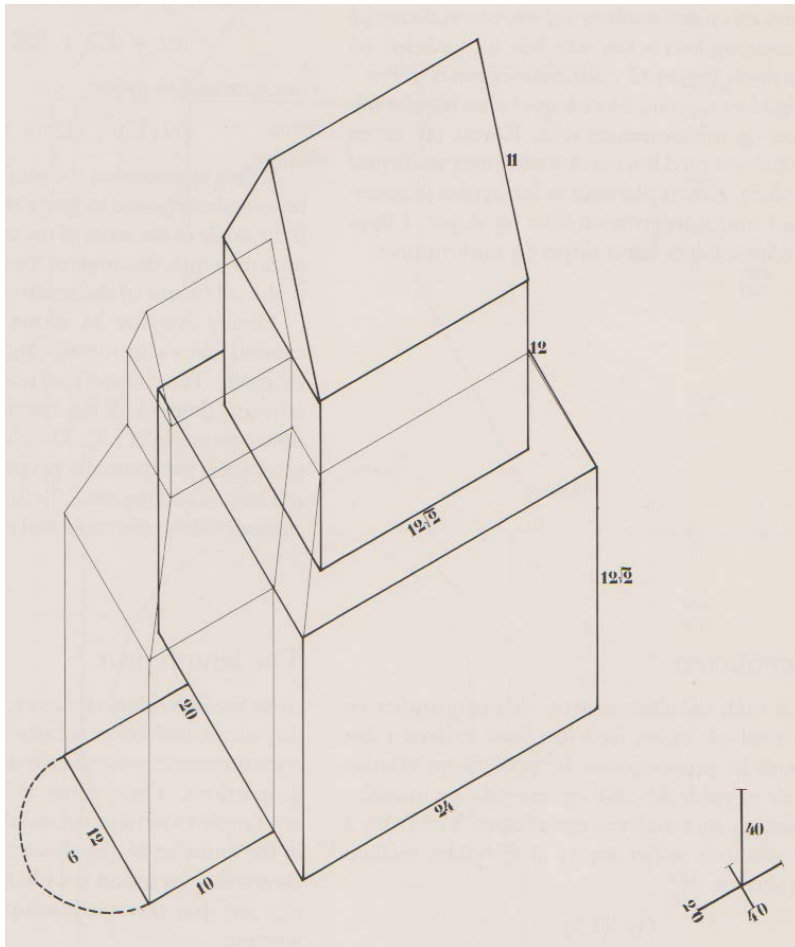

Fig. 45 The ratios used in the construction of Lomen Stave Church.
 Source: Jensenius 1988: 58.

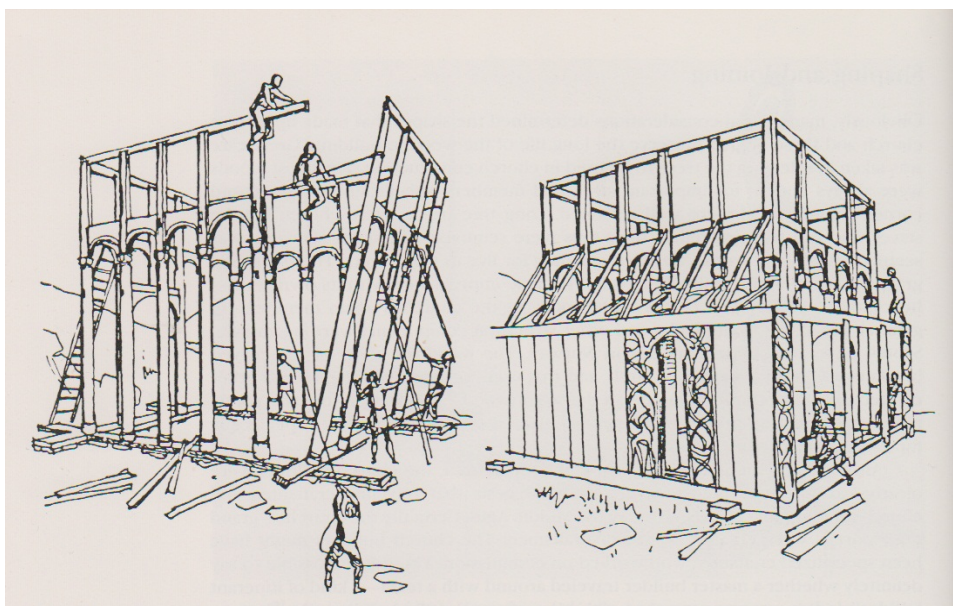

Fig. 46 Raising a stave church. Source Holan 1990: 180.



Fig. 47 Haltdalen Stave Church as simple Two-Cell style.



Fig. 48 Borgund Stave Church as a Basilica style church.



Fig. 49 Uvdal Stave Church. Source:< <http://www.stavkirke.no/index.php/en/the-stave-churches/ad/uvdal-stavkirke,28>> [Accessed 2 January 2015]



**Rødven Stave Church. Source:
Valebrokk and Thiis-Evensen
2001: 80.**

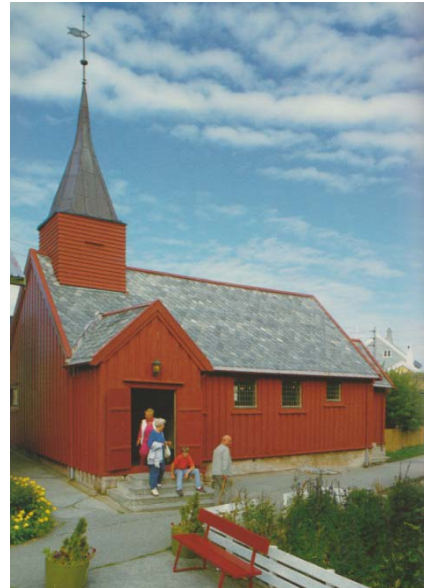

**Grip Stave Church. Source:
Valebrokk, and Thiis-Evensen
2001: 86.**



Kvernes Stave Church. Source: Anker and Havran 2005: 316.

Fig. 50 Møre Stave Churches.

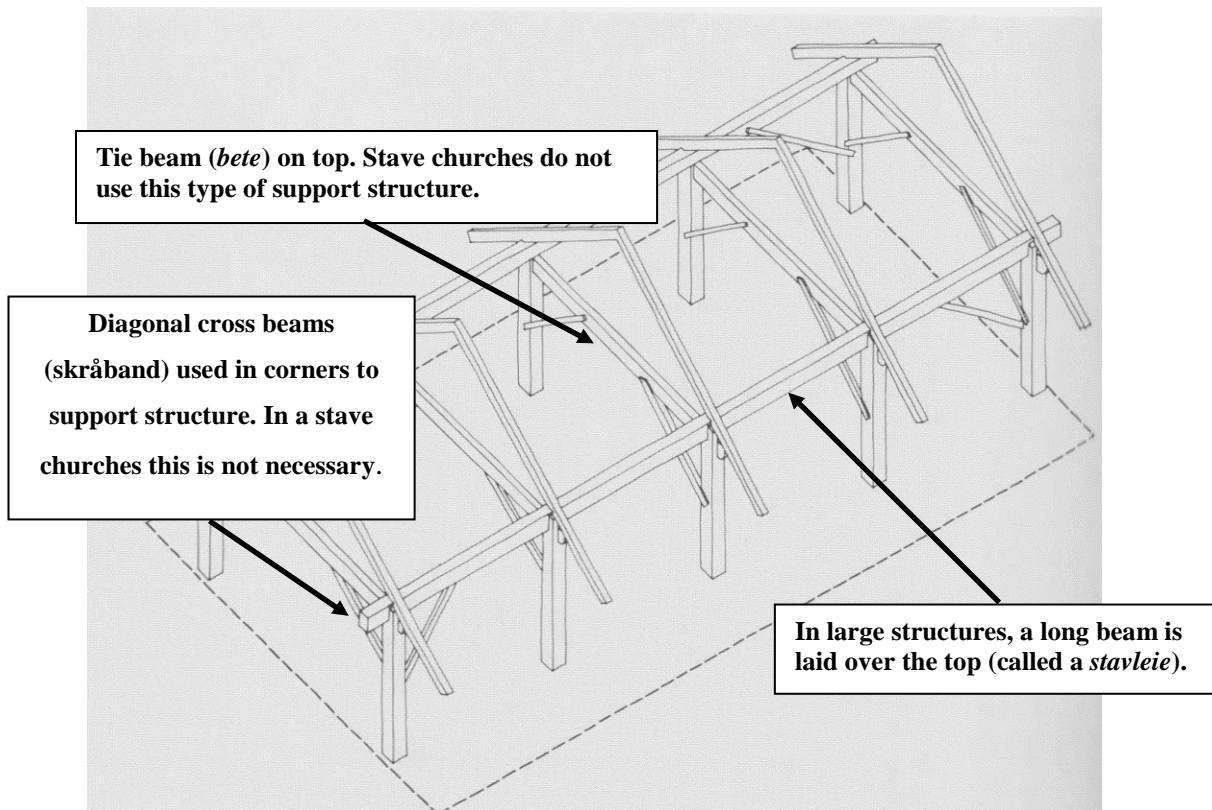

Fig. 51 Grindbygget perspective. Source: after Christie 1981:200.

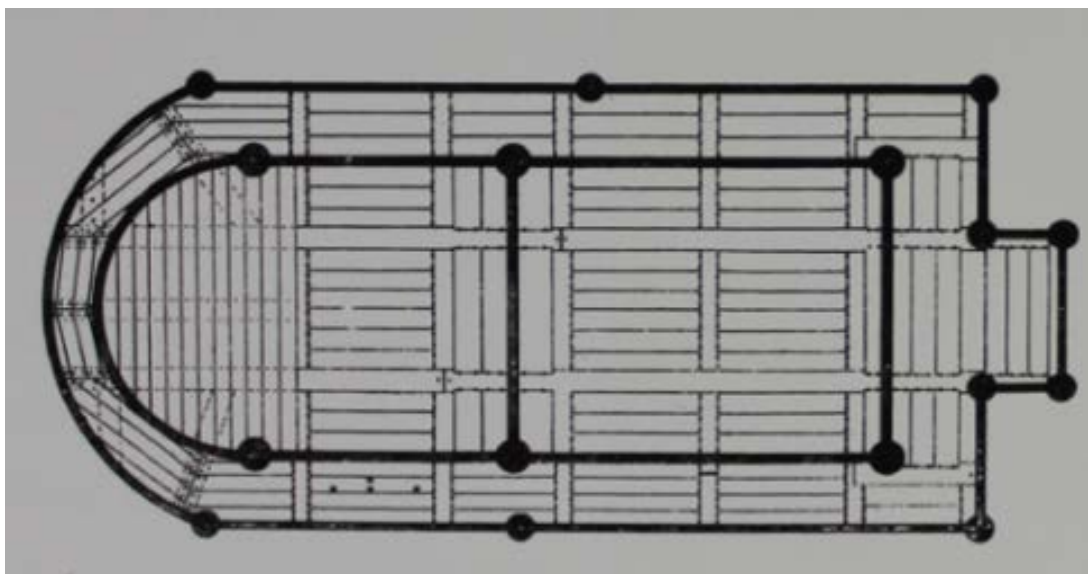

Fig. 52 Reinli Stave Church in its medieval configuration. The nave and the chancel are the same width. Used with permission from the Directorate for Cultural Heritage, secondary source: Ankar and Havran 2005: 244.

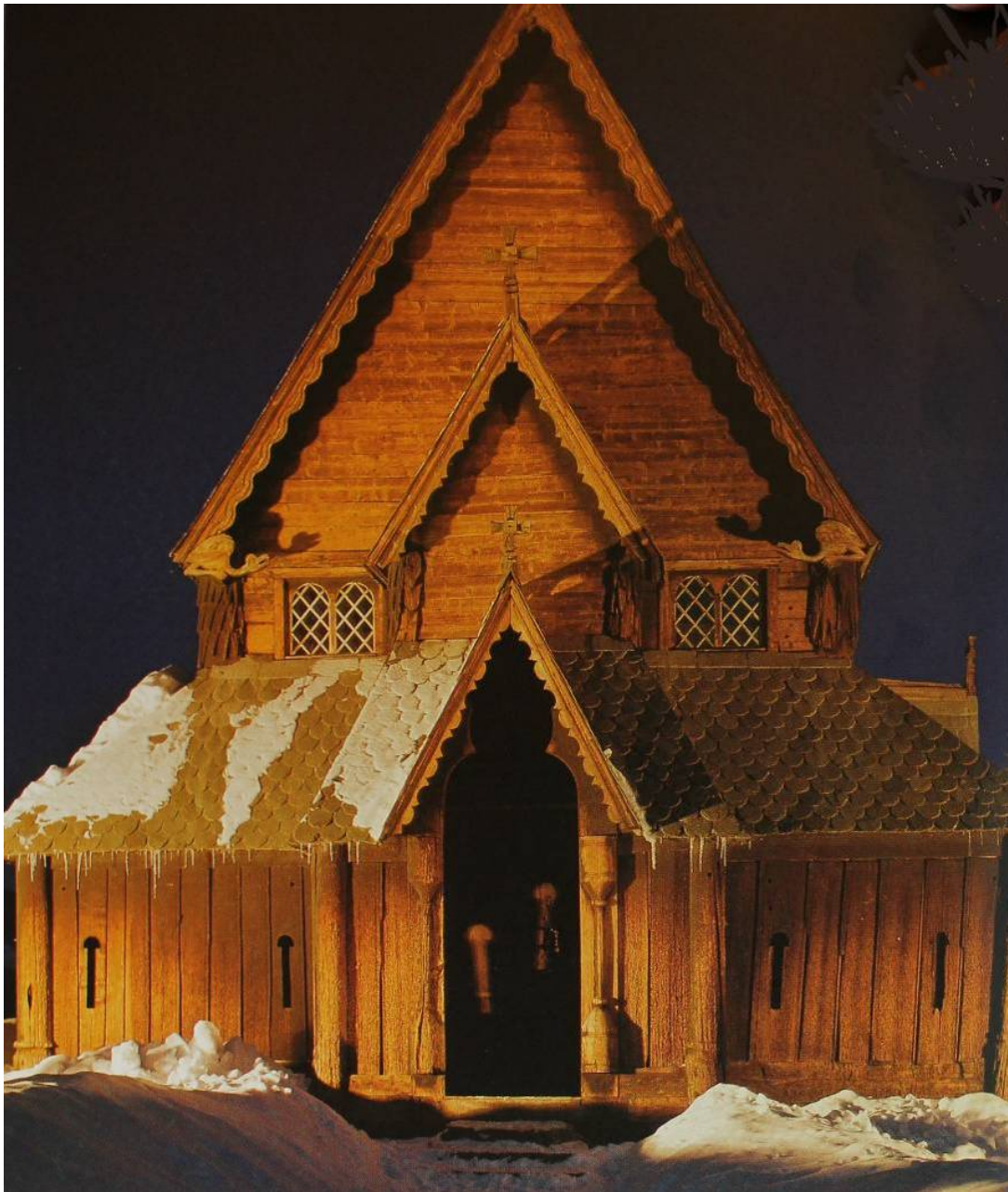
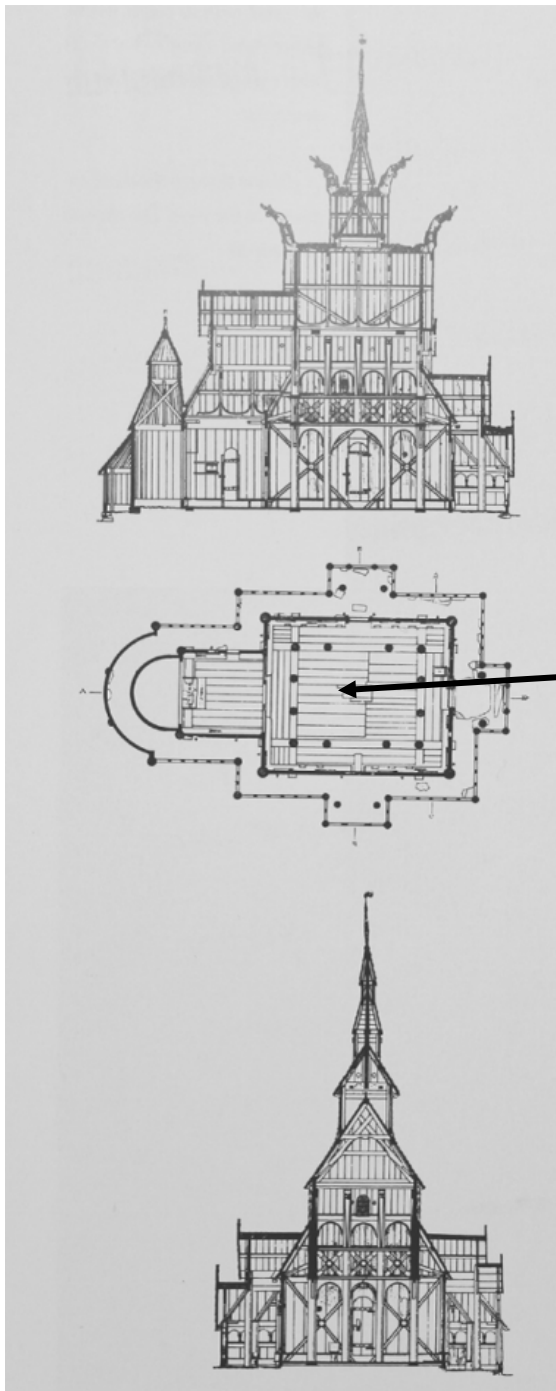

Fig. 53 Reinli Stave Church. Source: Valebrokk and Thiis-Evensen 2001: 68.



The interior (and likely the earliest phase) of the church is clearly is based on the rectangular nave and square chancel see in the Simple two-cell style.

Fig. 54 Technical drawing of Borgund Stave Church by Henrik Bull.
Used with permission from Riksantikvaren, Directorate for Cultural Heritage.

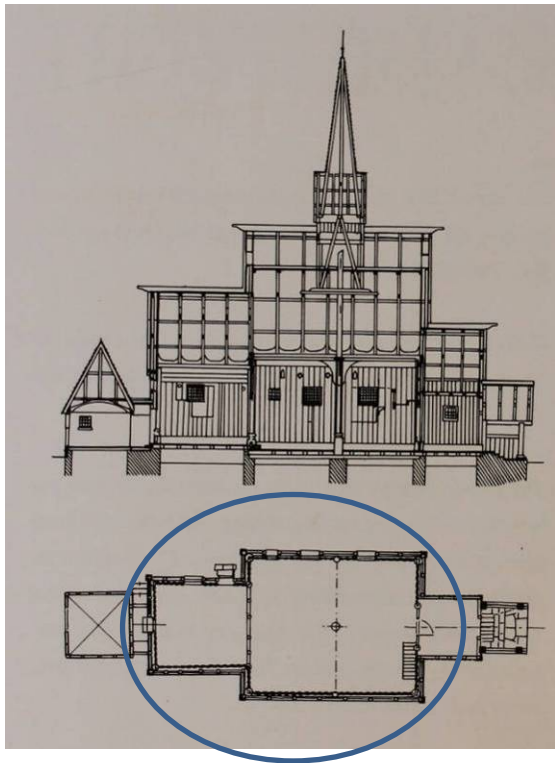

Fig. 55 Høyjord Stave Church plans and elevations. Although the church has been extensively reconstructed, the Nave and Chancel pattern are preserved in the floor plan (used with permission from the Directorate for Cultural Heritage, secondary source: Ankar and Havran 2005: 212).

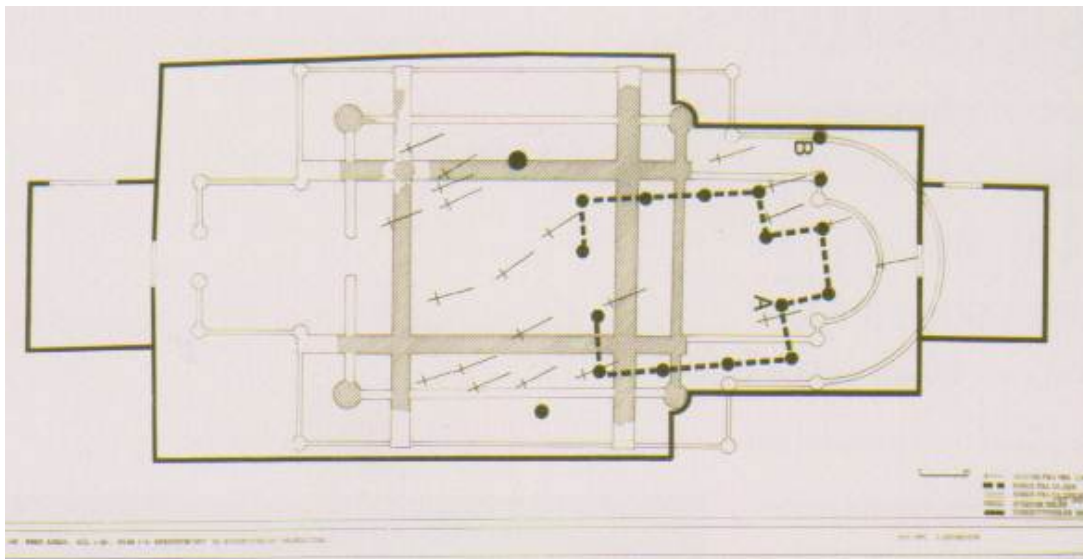

Fig. 56 Archaeological overview of Høre Stave Church. This sources from an unpublished plan created by Jørgen Jensenius in 1979. The original is stored in the Riksantikvaren. The location of the coin used for dating evidence is the sideways “B” on the upper right hand of the diagram. This early structure is interpreted as a two-cell post structure.

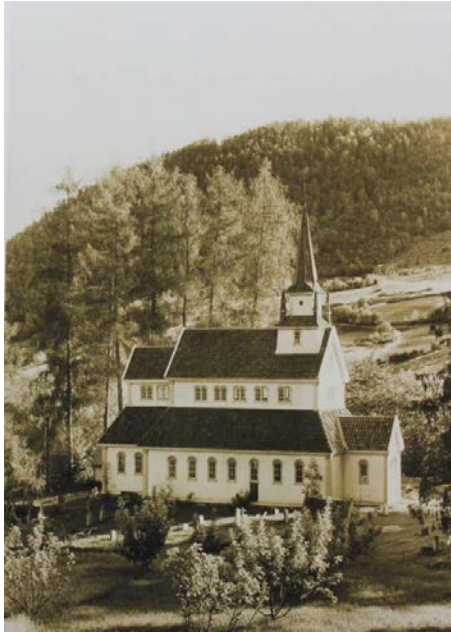
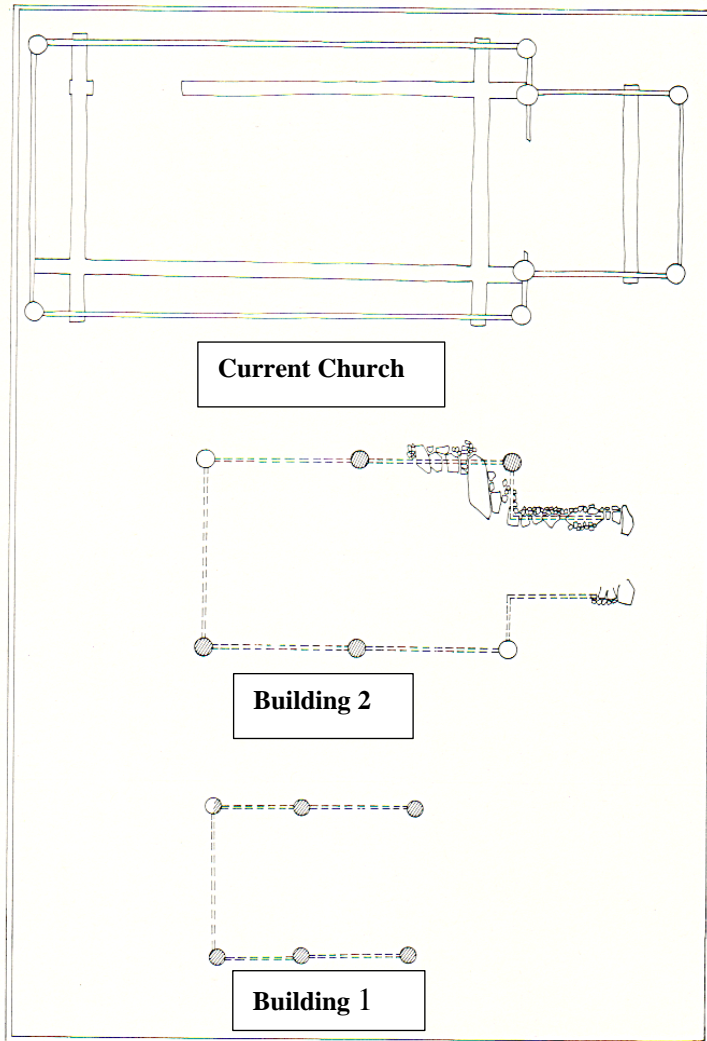
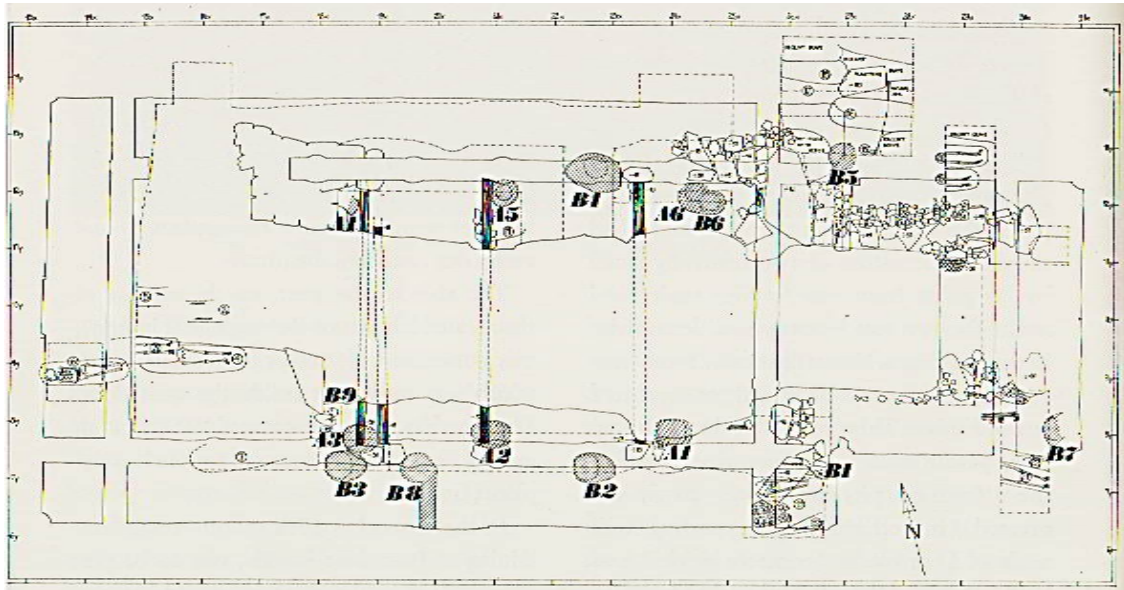

Fig. 57 Kaugpanger Stave church. The image on the left is from 1964 (used with permission from the Directorate for Cultural Heritage, secondary source Ankar and Havran 2005: 127.). The image on the right is from 2015 (photo by author).



In this diagram the top church plan conforms to the church outline on the excavation overview above. The middle church in this diagram is clearly of a two-cell from. The bottom structure was incomplete and was likely burned down. Image source: Bjerkens and Lidén 1975.

Fig. 58 Kaupanger church excavation details.

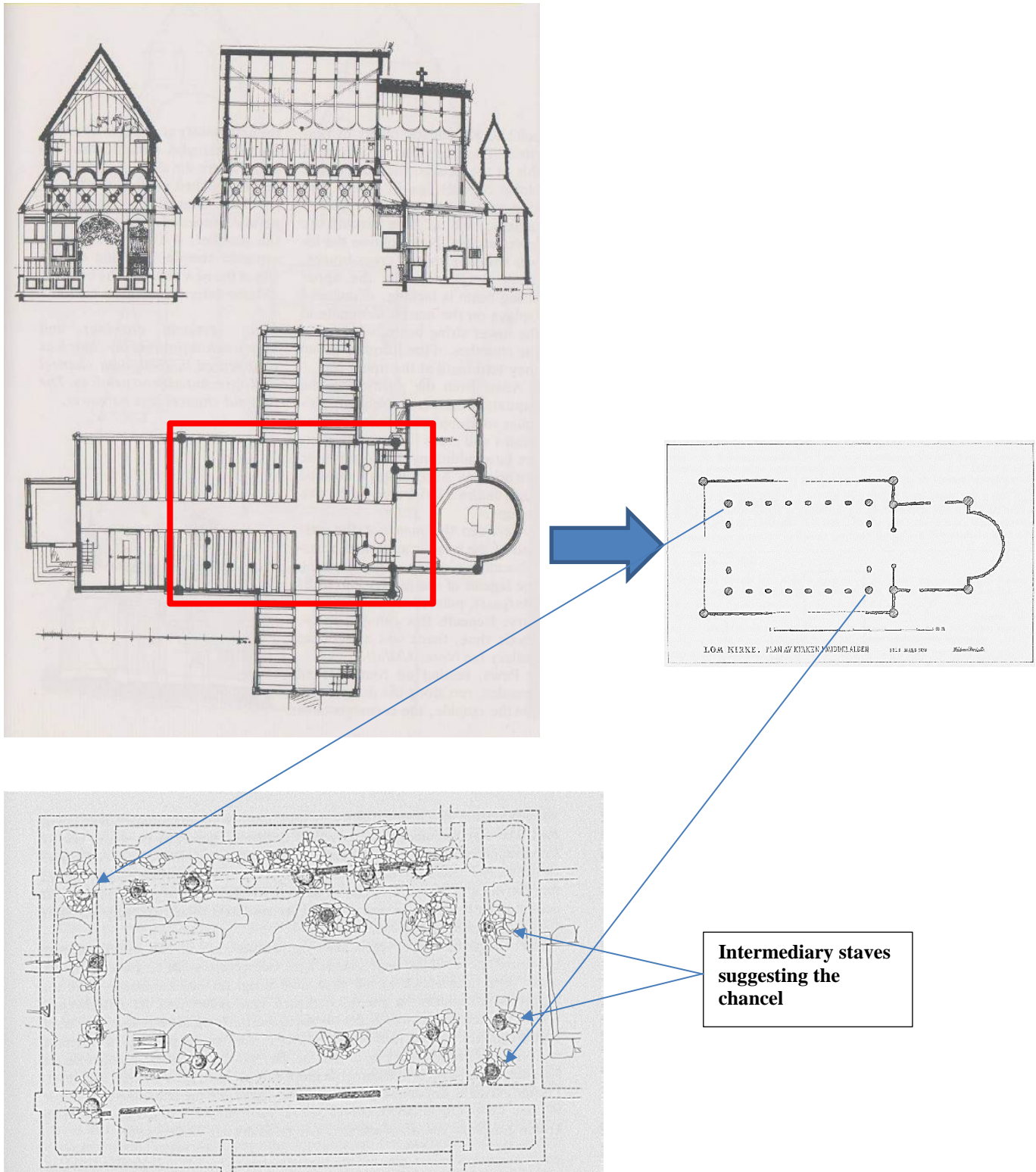

Fig. 59 Lom Stave Church plan with excavation details. The top left image is Lom Stave Church as it appears today (drawing by Håkon Christie , secondary source Bugge 1983: 59). The red square represents the location of the medieval church (the image on the right, sources from the reconstruction by Christie 1978: 194) The stave construction in the nave is built on a wooden chassis. This chassis is represented by the dotted lines on the excavation diagram (source Christie 1978:109). The post-holes of the older church are below these beams. It can be seen that the original form of this church, is a two-cell structure.

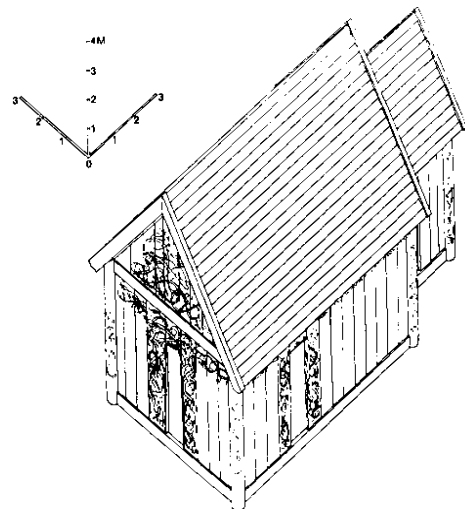
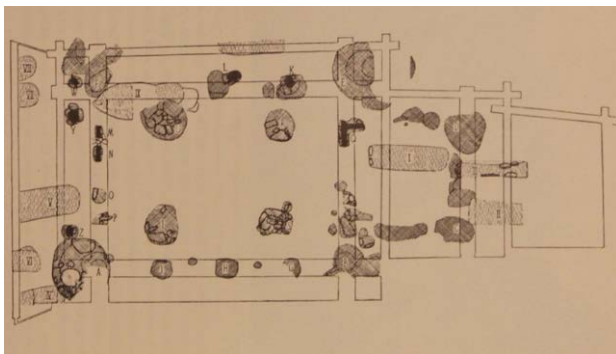
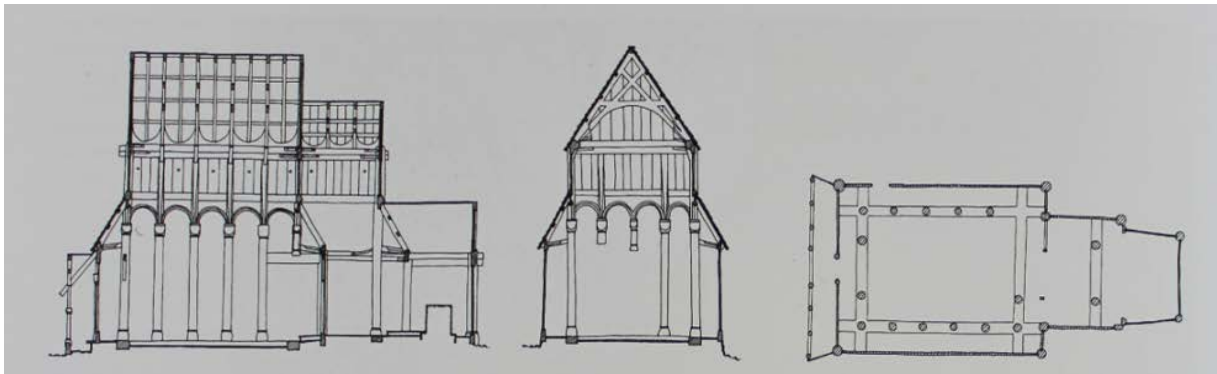

Fig. 60 Urnes Stave Church excavation details. The top image is how Urnes appears today (used with permission from Riksantikvaren, Directorate for Cultural Heritage, secondary source: Ankar and Havran 2005: 104.) The bottom left images is the site overview from the excavation in 1959. The isometric utilizes both archaeological evidence, as well as a reconstruction of the existing parts (Krogh 1971: 151)



Fig. 61 Urnes portal and wall, the type site for the Urnes style. A metre ranging rod is visible in the centre.

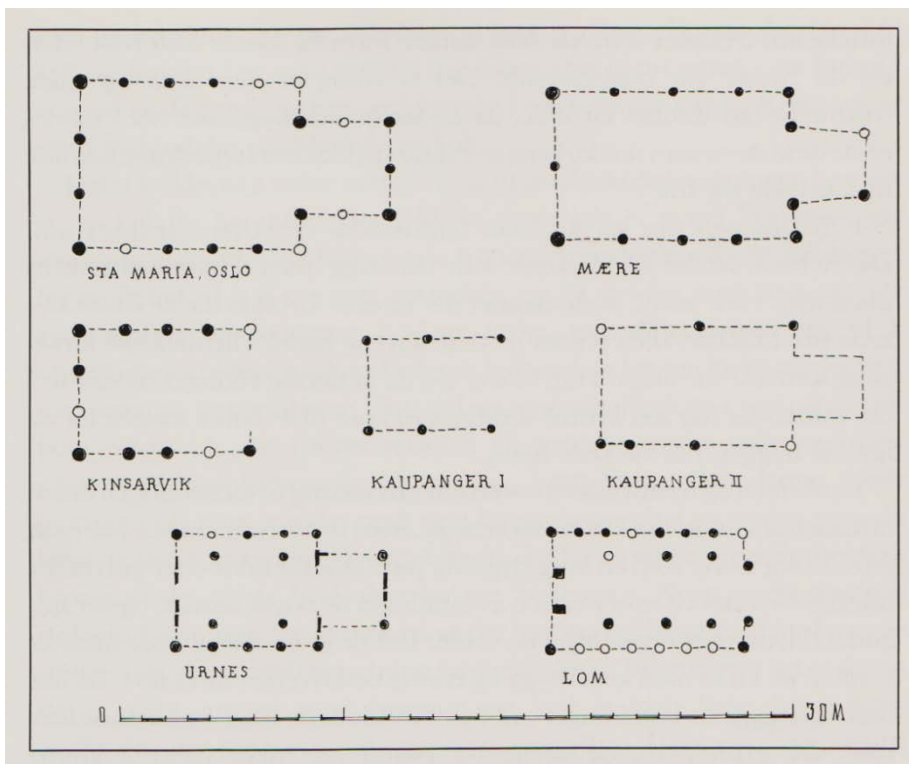

Fig. 62 A compilation of church excavations. The original chancel has often been destroyed by the inclusion of deep burial vaults. As far as is known, all of these structures are two-cell structures. Image source: Christie 1981: 205.



Fig. 63 Carved board with Urnes style from Brågarps kyrka, Scania, Sweden. HML

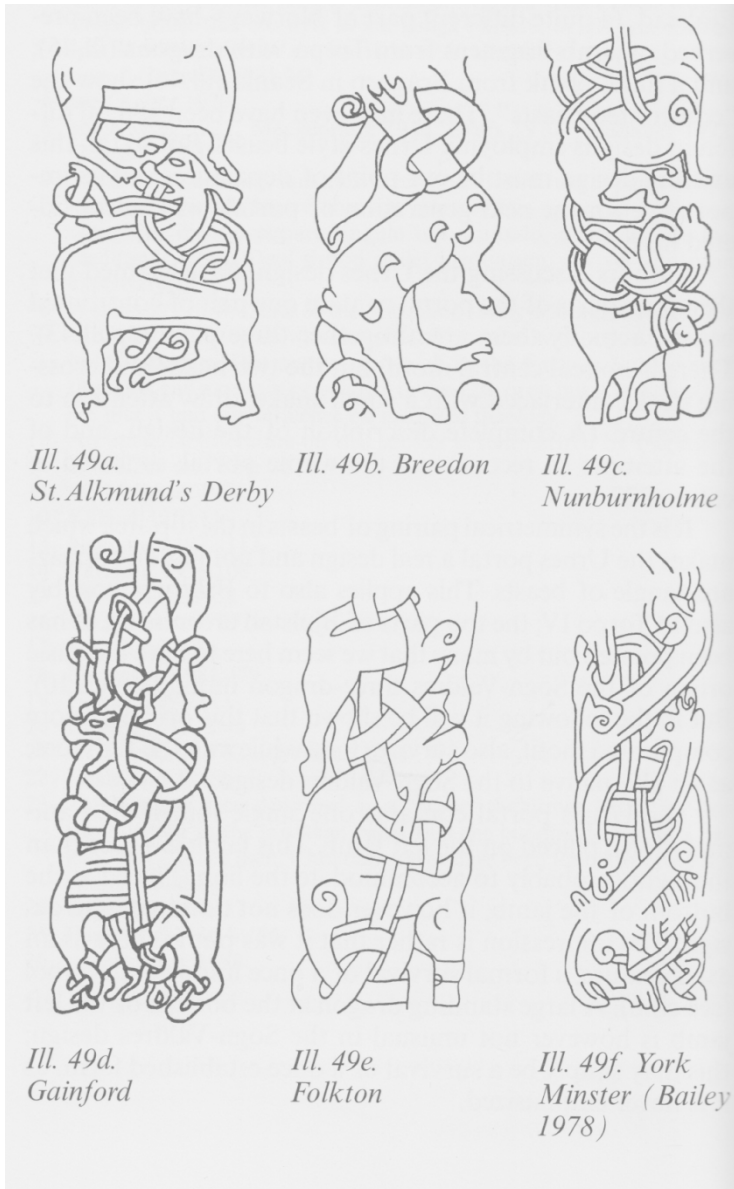
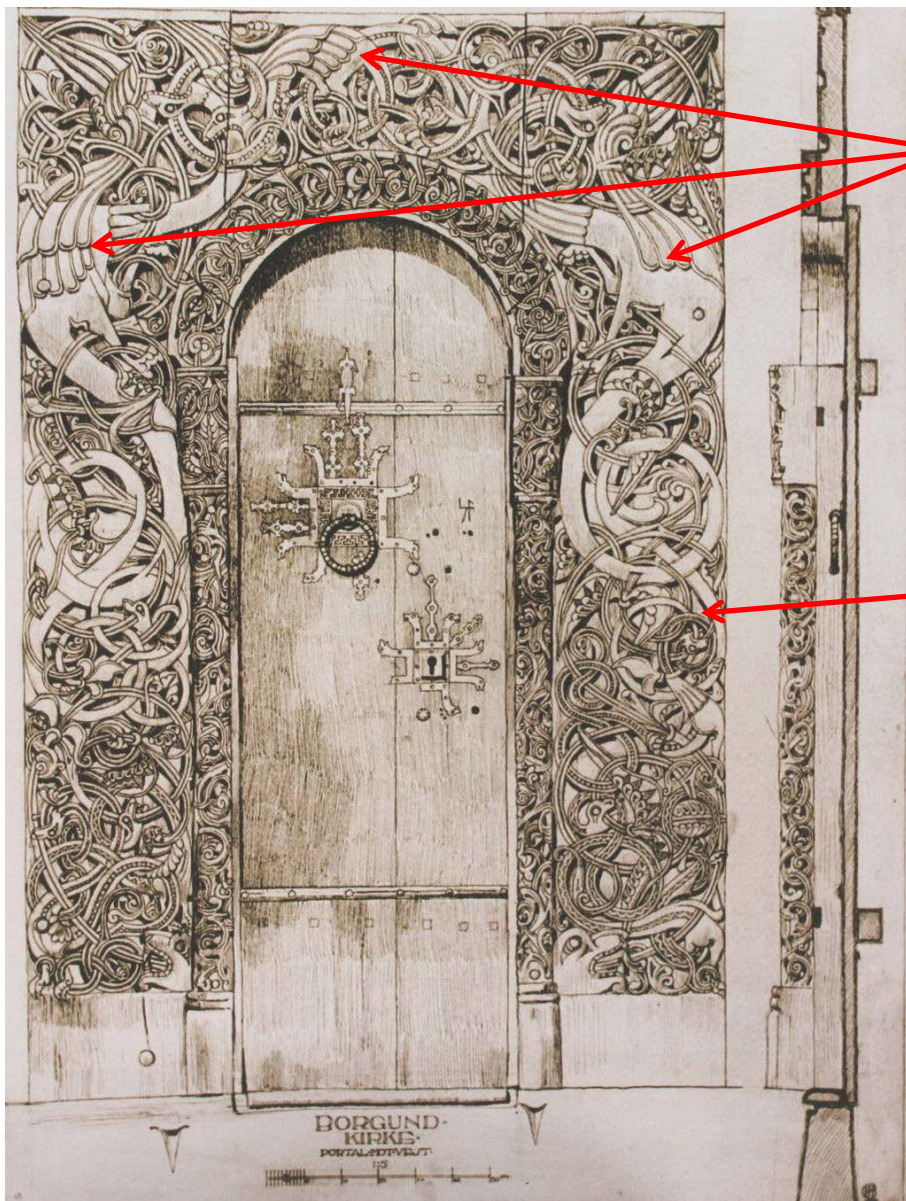

Fig. 64 "Beast Chain" examples from the Anglo-Saxon tradition. Source: Hohler 1999a: 60. The beast chain image on the right is from the pilaster base Vågå church, Vågå, Oppland, Norway. Source: Blindheim 1966: Image 77



Fig. 65 Sample cushion capital at Urnes Stave Church.



The highly stylized three dragon motif can be seen on the top half

The vine motif can be seen on either side of the

Fig. 66 Borgund Stave Church portal. Image used with permission from Riksantikvaren, Directorate for Cultural Heritage.



Ål Kirke portal c. 1150. HMM

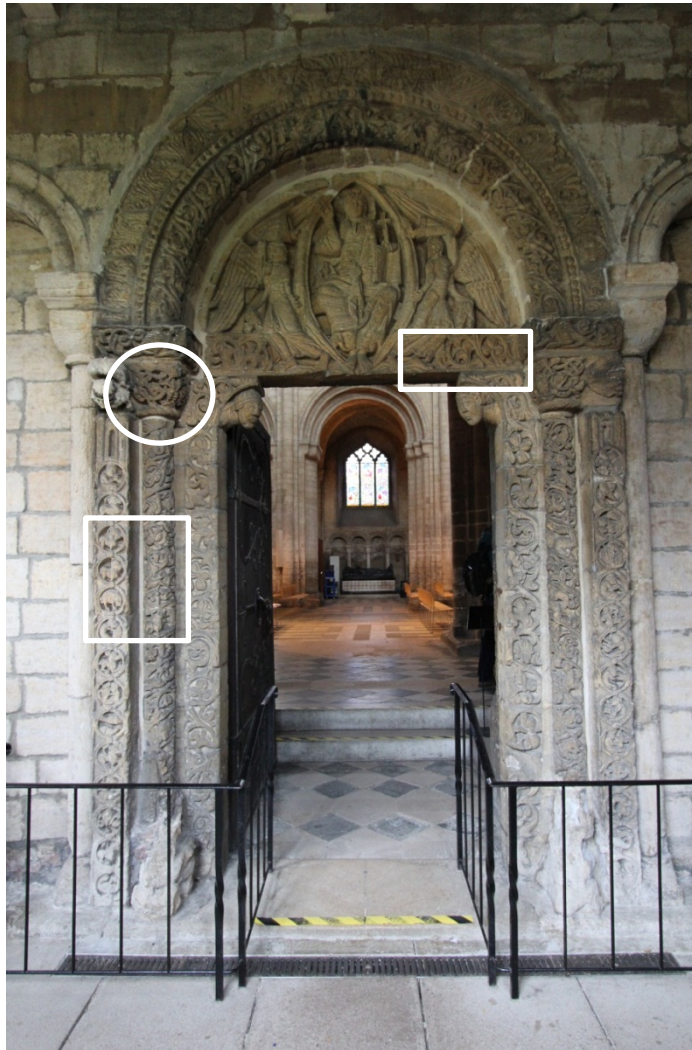

Prior's Doorway in Ely Cathedral.



Sauland Kirke portal c. 1200
(placed horizontally for comparison purposes). HMN



Sauland Kirke. HMN



Fig. 67 A comparison of stave church decoration to Prior's Doorway in Ely Cathedral.



Fig. 68 Lombardic styled lion capitals. The left is from Lund Cathedral, Sweden. The right is from Borgund Stave Church. The bottom (much weathered) image is a lion bending backwards on Ely Cathedral's Prior's door (UK).

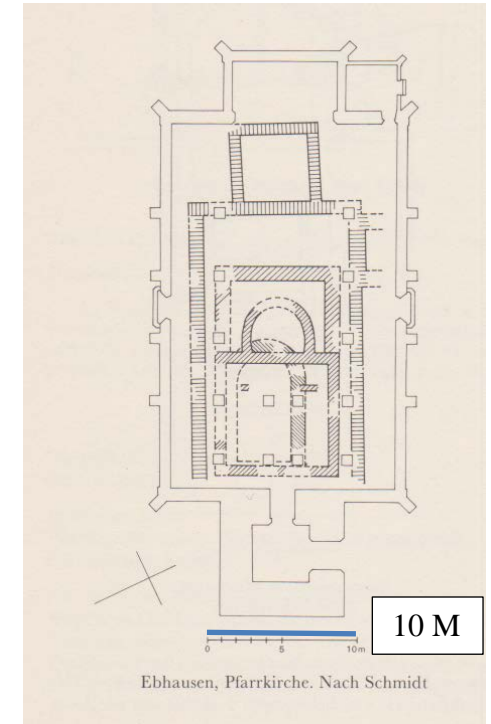
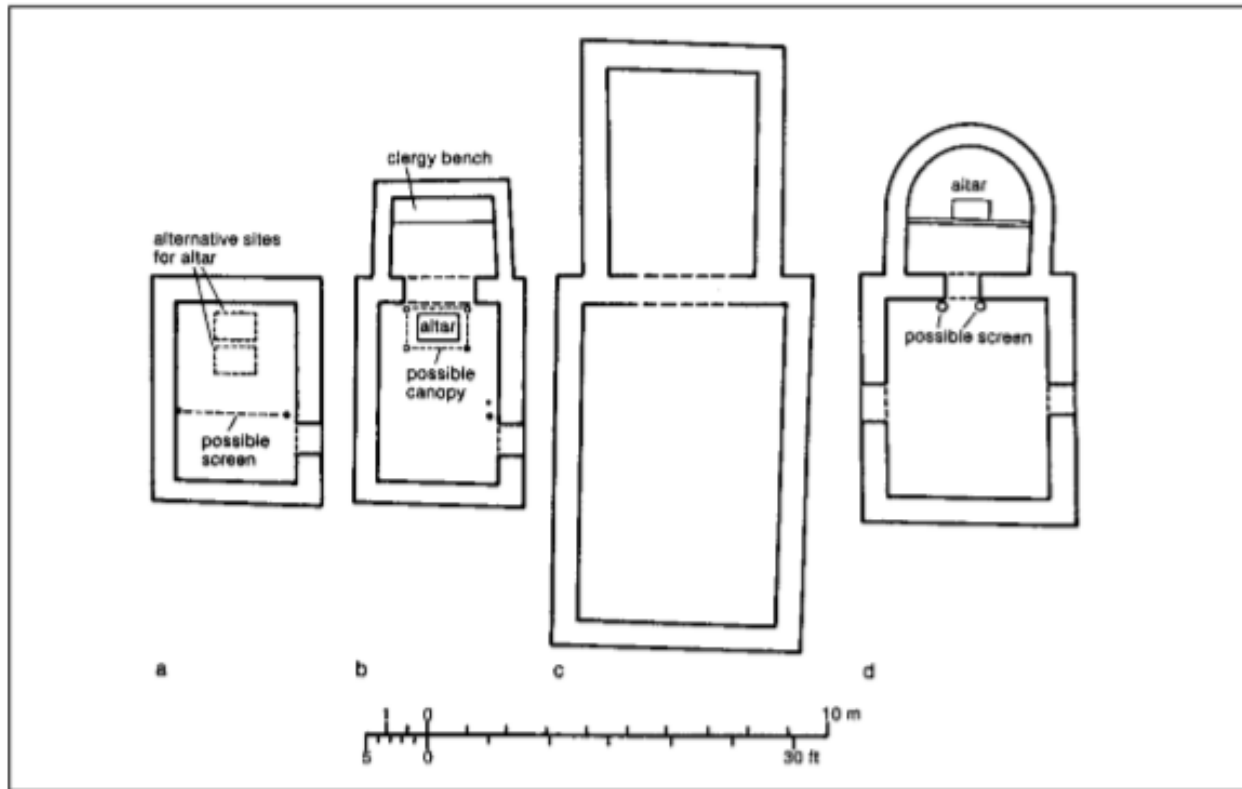

Fig. 69 Church evolution. The left hand image is a comparison of the three phases seen at Raunds Furnells, (Northamptonshire). It shows the pattern of a one room structure being enlarged, and ultimately becoming a two-cell church (information and photo source: Barwell, 2004: 14). Britain is not alone in having examples of this type of structural evolution. The example on the right is Ebhausen church (Ebhausen, Calw, Karlsruhe, Baden-Wuerttemberg, Germany) Photo source: Oswald, Schaefer and Sennhauser 1991: 102.

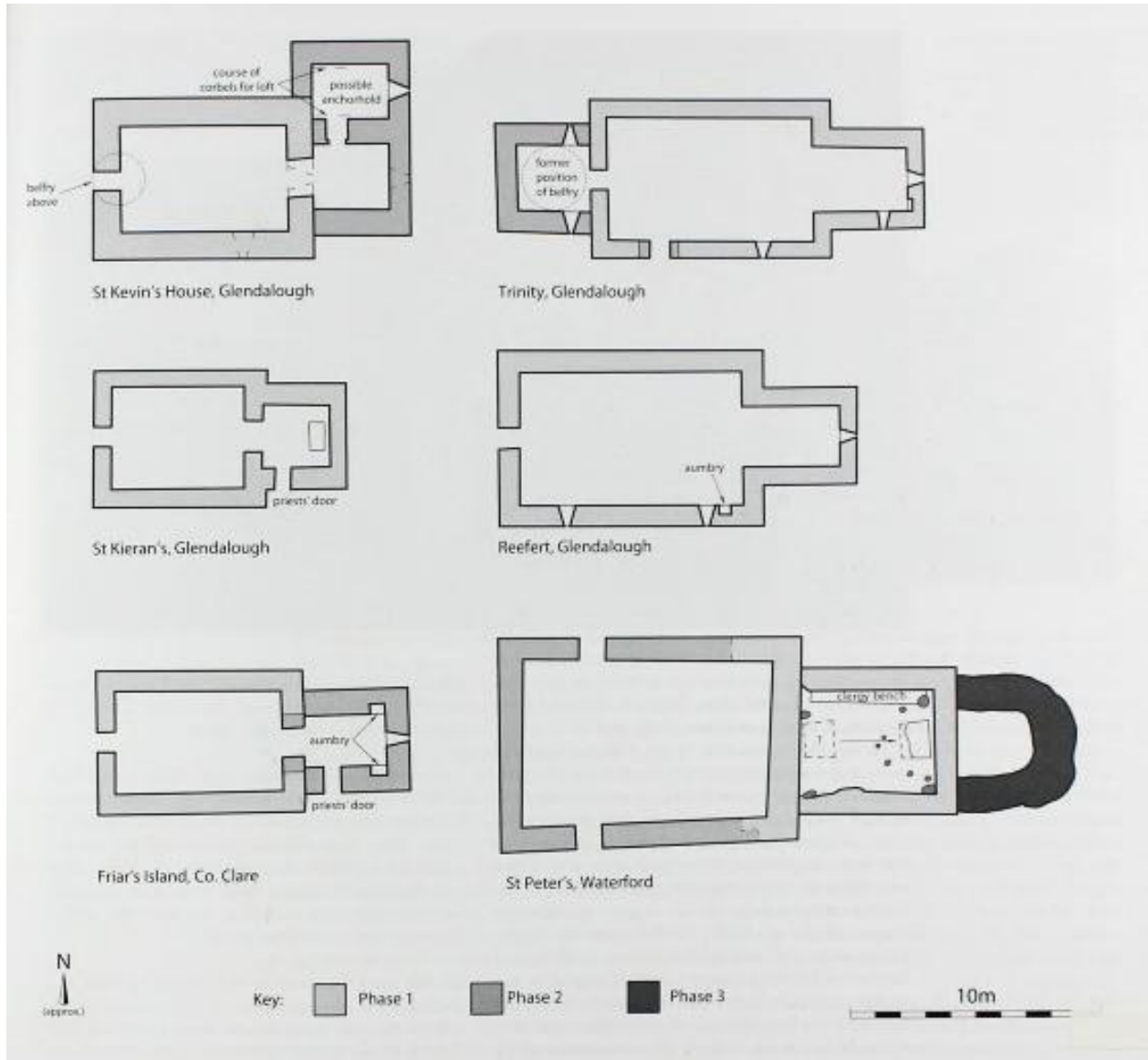

Fig. 70 Irish churches with chancels added to them. Source: Ó Carragáin 2010: 193.

Side by Side Comparisons of Early Medieval Church plans to scale

10 Meters

Anglo-Saxon

Medieval Norwegian Stone

Norwegian Stave Church

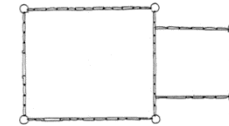
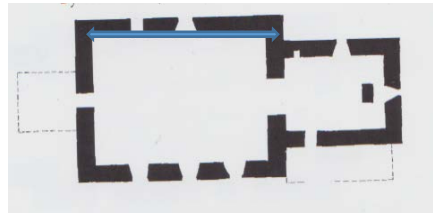
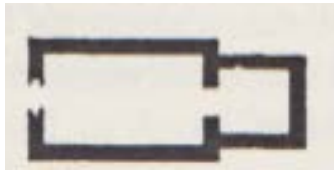

Chithurst Church,
Tayler and Tayler 2011
V3: 982.

Byneset Kirke, Ekroll, Stige,
Havran 2000: 269.

Haltdalen Stave Church after Christie
1976:67.

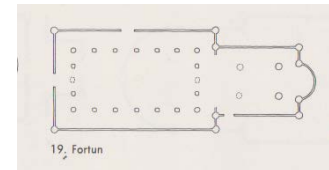
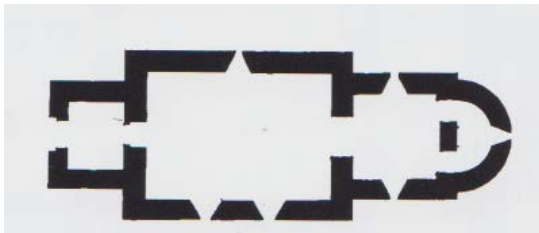
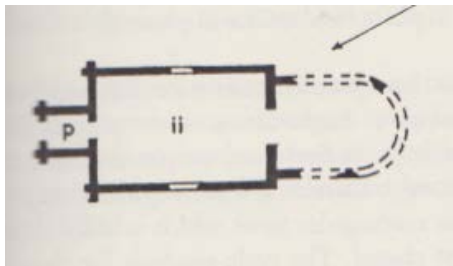

Canterbury St Pancras Tayler and
Tavler 2011 V3: 979.

Talgie Kirke. Ekroll, Stige, Havran 2000:
257

Fortun Stave Church
Bugge: 1983: 83

Fig. 71 Anglo-Saxon and Norwegian Stone Churches



Haltdalen Stave Church (1170).



Twelfth century Værnes Church, Norway.



Twelfth century Kalvslund Kirke, Denmark.



12th-century Hedareds Stave Church, Sweden. Source: Ekhoﬀ 1916:185.



Early 12th century two-cell Church of the Trinity, Glendalough (Co Wicklow), Ireland.

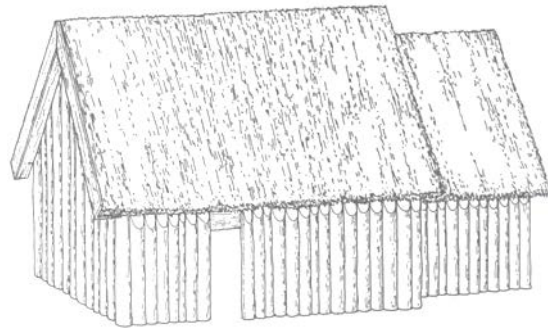

Late 11th century Greensted Church (Essex) reconstruction. Source: Ahrens 2001:102

Fig. 72 Regional examples of Two-Cell structures.



Side view of Haltdalen and Escomb churches



Chancel view of Haltdalen and Escomb churches

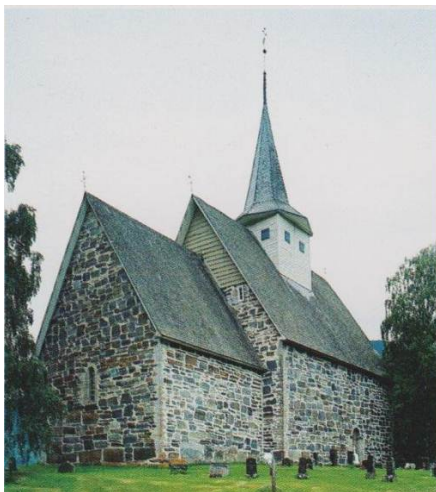

Vestre Slidre Kirke stone church (c. 1200) Norway for comparison purposes. Source: Ekroll 2000:72

Fig. 73 Comparison of Escomb and Haltdalen.

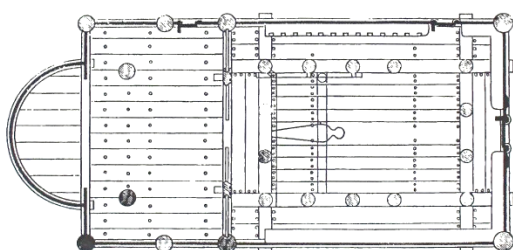
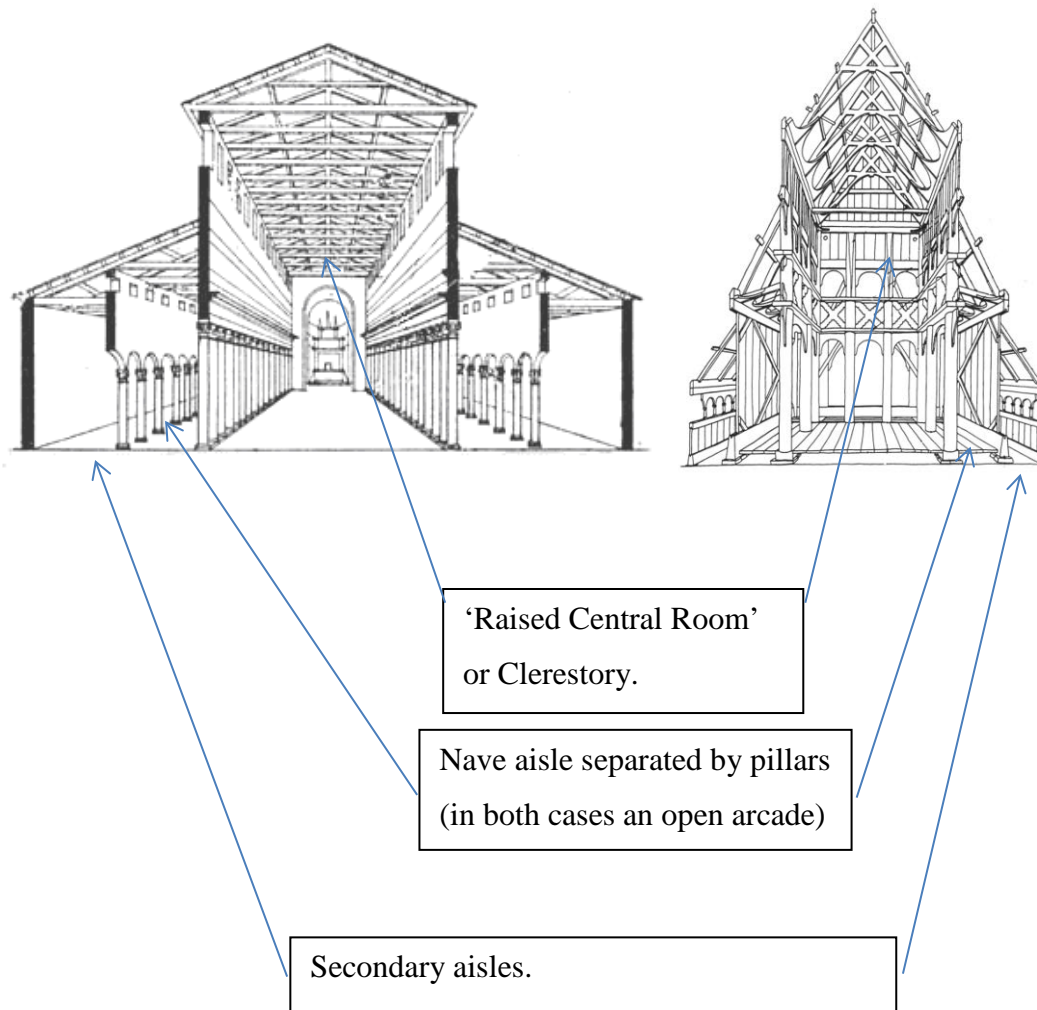

Torpo ground plan

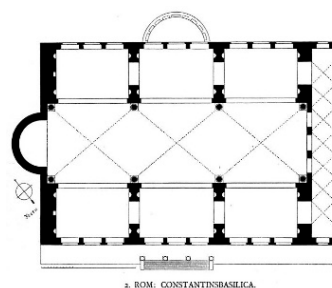

Basilica plan of Maxentius and Constantine

Fig. 74 Stave Church as wooden basilica.

Perspective of St Peter's (on top) after Banister Fletcher's 1905 architectural reconstruction
 <<http://t771unit2.pbworks.com/w/page/6766428/Chapter%208%3A%20Early%20Christian%20and%20Byzantine%20Art>> [Accessed 24 March 2013]. Borgund Stave Church perspective after Håkon Christie. Torpo ground plan (on bottom left) source: Dietrichson 1892: 278. Basilica plan of Maxentius and Constantine source:
 <http://en.wikipedia.org/wiki/File:Dehio_6_Basilica_of_Maxentius_Floor_plan.jpg> [Accessed 03 December 2013].



Escomb raised roof.

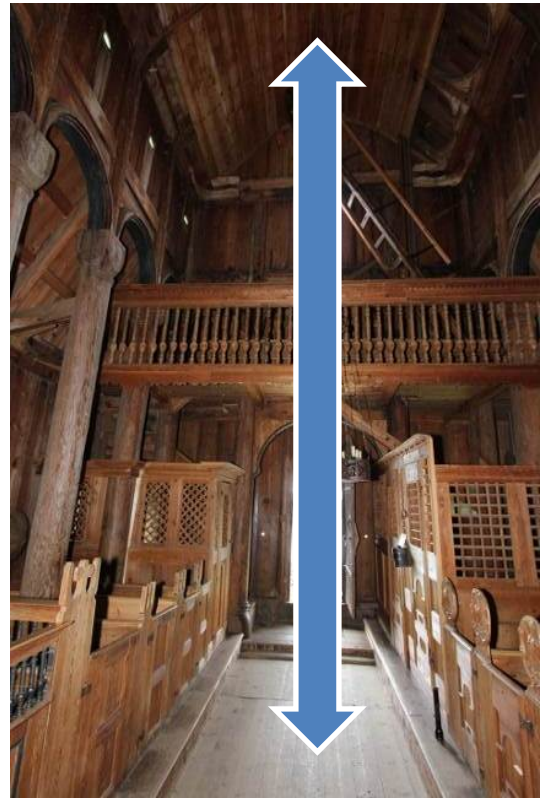

Urnes raised roof.

Fig. 75 Central Raised Rooves.

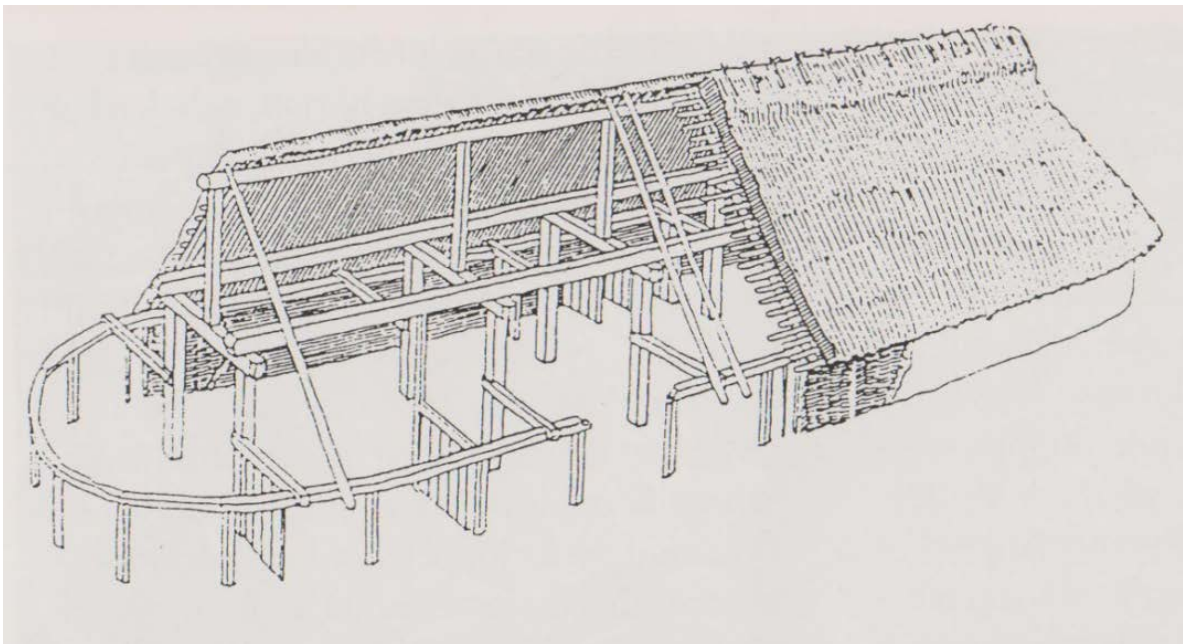

Fig. 76 Bronze Age structure from 1000 BCE in Jylland in Denmark. Source: Burenhult 1999:22.

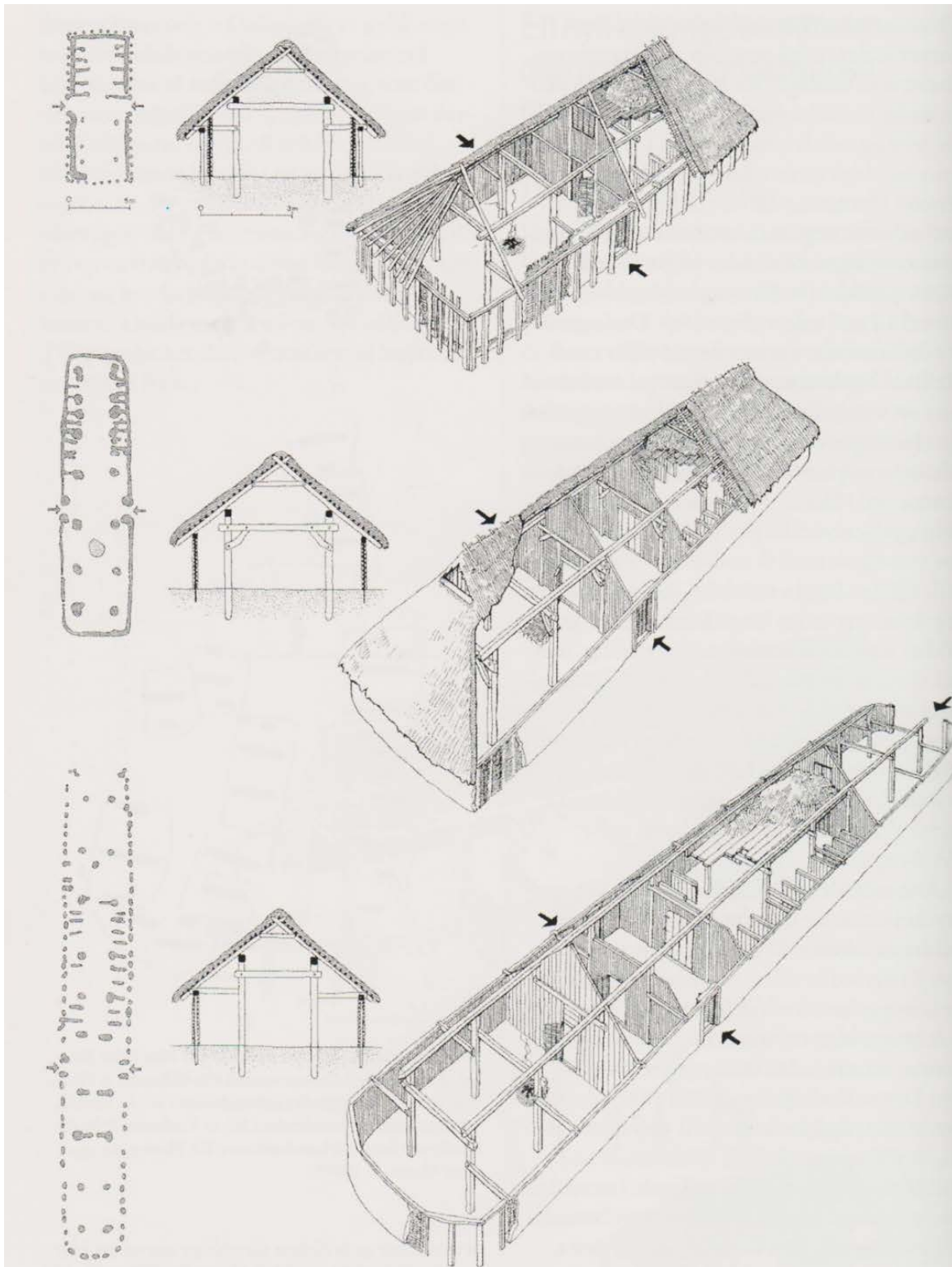

Fig. 77 Three Danish longhouses spanning 1000 years. Source Berglund 1999: 188. The building at the top is from 500-300 BCE from Grøntoft, the middle structure is 100 BCE to AD 100 from Hodde; and the bottom structure is AD 200-500 from Vorbasse.

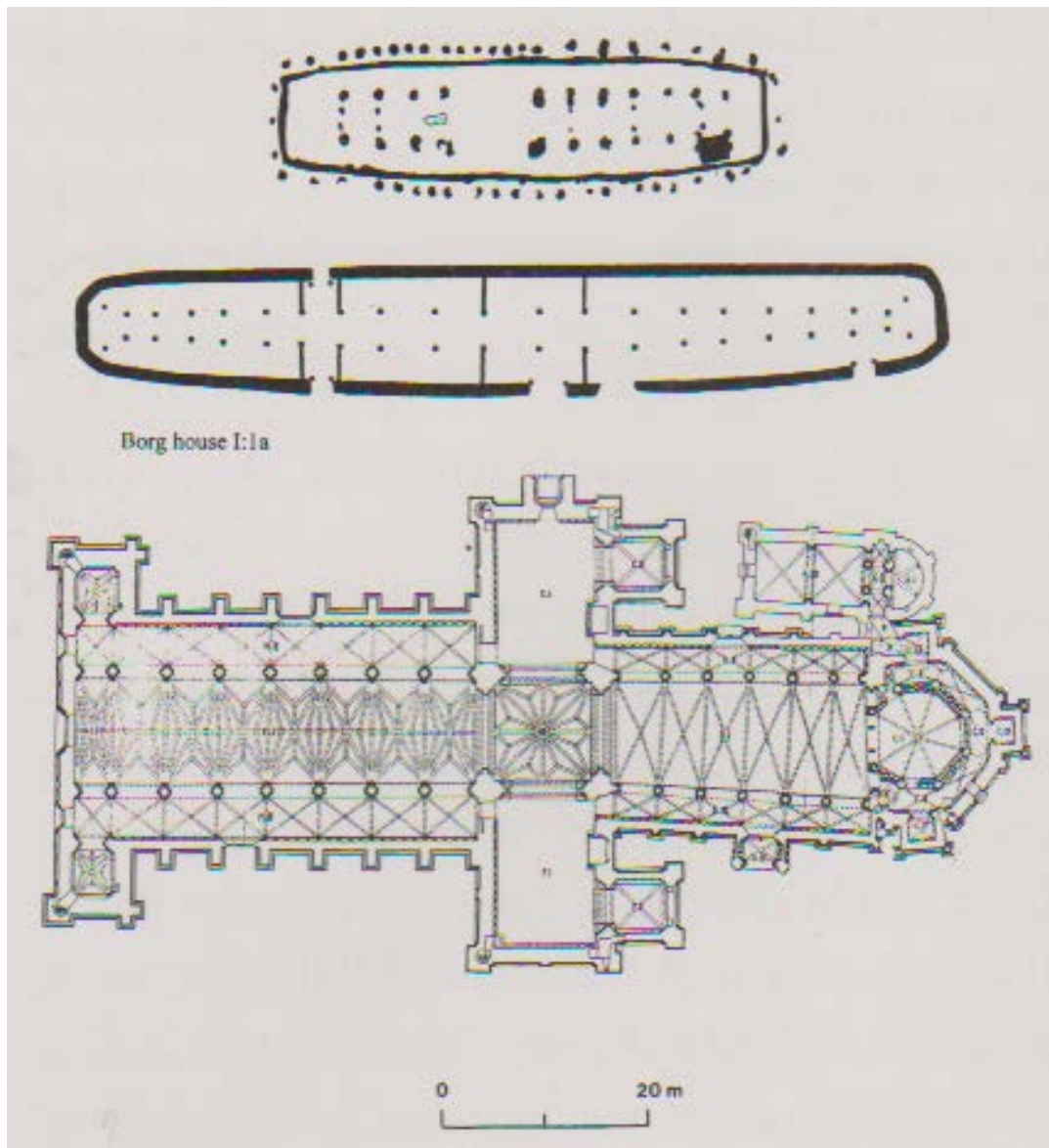
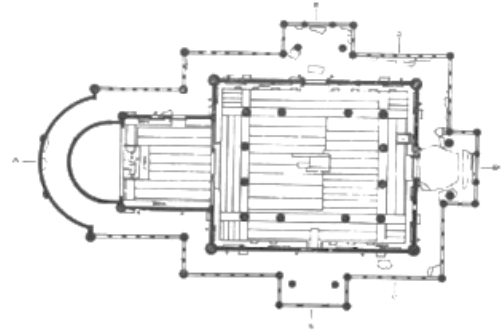

Fig. 78 Relative Hall sizes, and their similar superstructure. Source: after Steinsland 2005: 288.



Fig. 79 Borgund external ambulatory c. 1200.



Plan source: used with permission from

Riksantikvaren (Directorate for Cultural Heritage, secondary source Ankar and Havran 2005: 146).



Reliquary from the demolished stave church in Filefjell (c. 1240). DKS



Reliquary from Hedalen Stave Church. BRM

Fig. 80 Extant reliquaries.

ST. DROTEN I LUND

FORSØK PÅ REKONSTRUKSJON VED ROAR HAUGLID -69

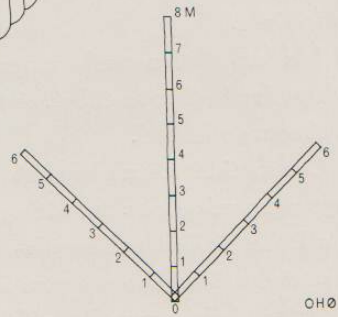
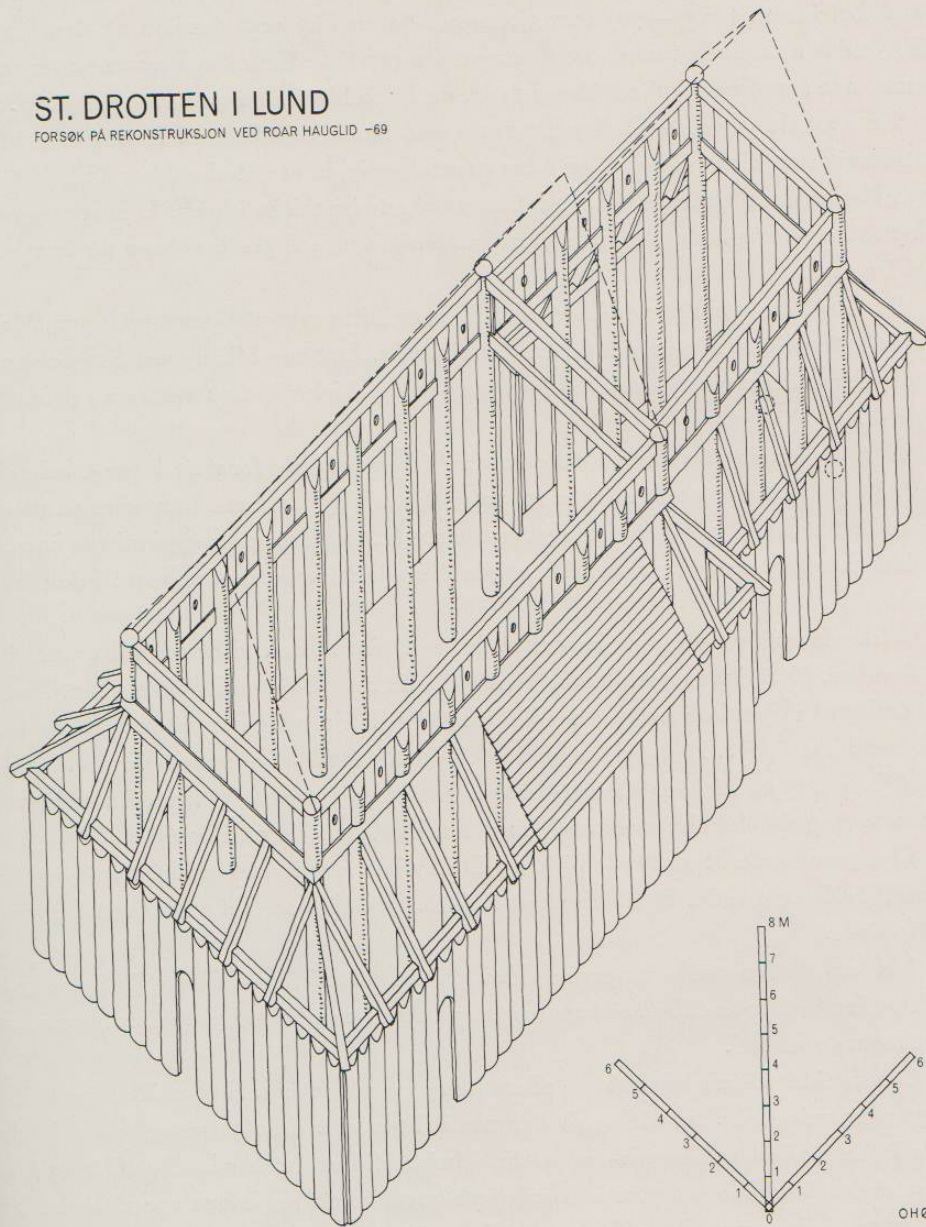

Fig. 81 St. Drotten, Lund, Sweden c. 1060. Isometric reconstruction by Hauglid 1976: 166.



Fig. 82 12th-century Eriksberg Shrine. HMS.



Fig. 83 Chartres Cathedral window, Bay 21, The life of Saint Julien l'Hospitalier, Signature panel.
Source: <http://www.medievalart.org.uk/chartres/21_pages/Chartres_Bay21_Panel01.htm> [Accessed 19 November 2011].

Stave church with mid-mast: Nes

1. Mid-mast
2. Floor beam
3. Floor consisting of floor planks
4. Sill beam
5. Wall planks
6. Corner post
7. Diagonal brace
8. Horizontal brace
9. Quadrant bracket
10. Wall plate, lower member
11. Tie beam
12. Wall plate, upper member
13. Quadrant bracket
14. Roof boarding
15. Rafter
16. Scissor brace
17. Purlin
18. Brace
19. Brace
20. Collar beam
21. Batten

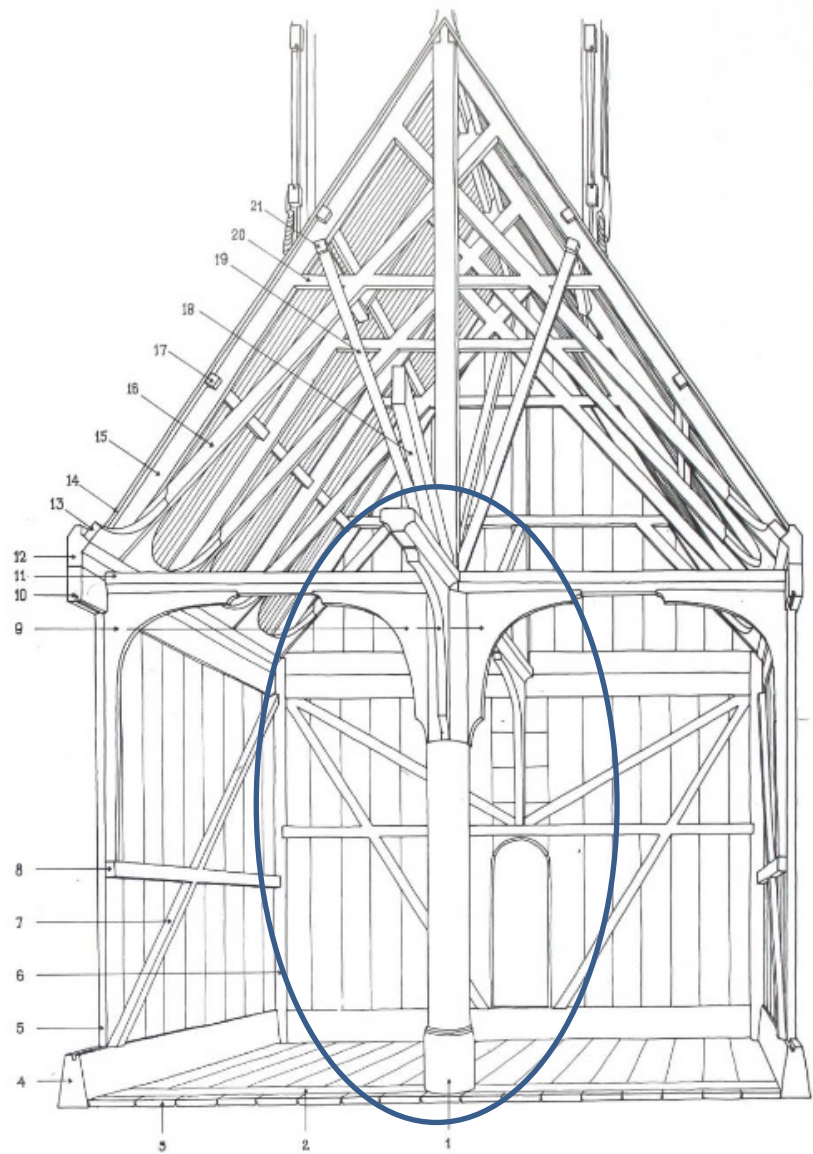

Fig. 84 Mid-Mast Stave Church.

Transverse section of a Mid-mast Church, with the roof structure highlighted. After Håkon Christie 1976, secondary source: Anker and Havran (2005: 339).

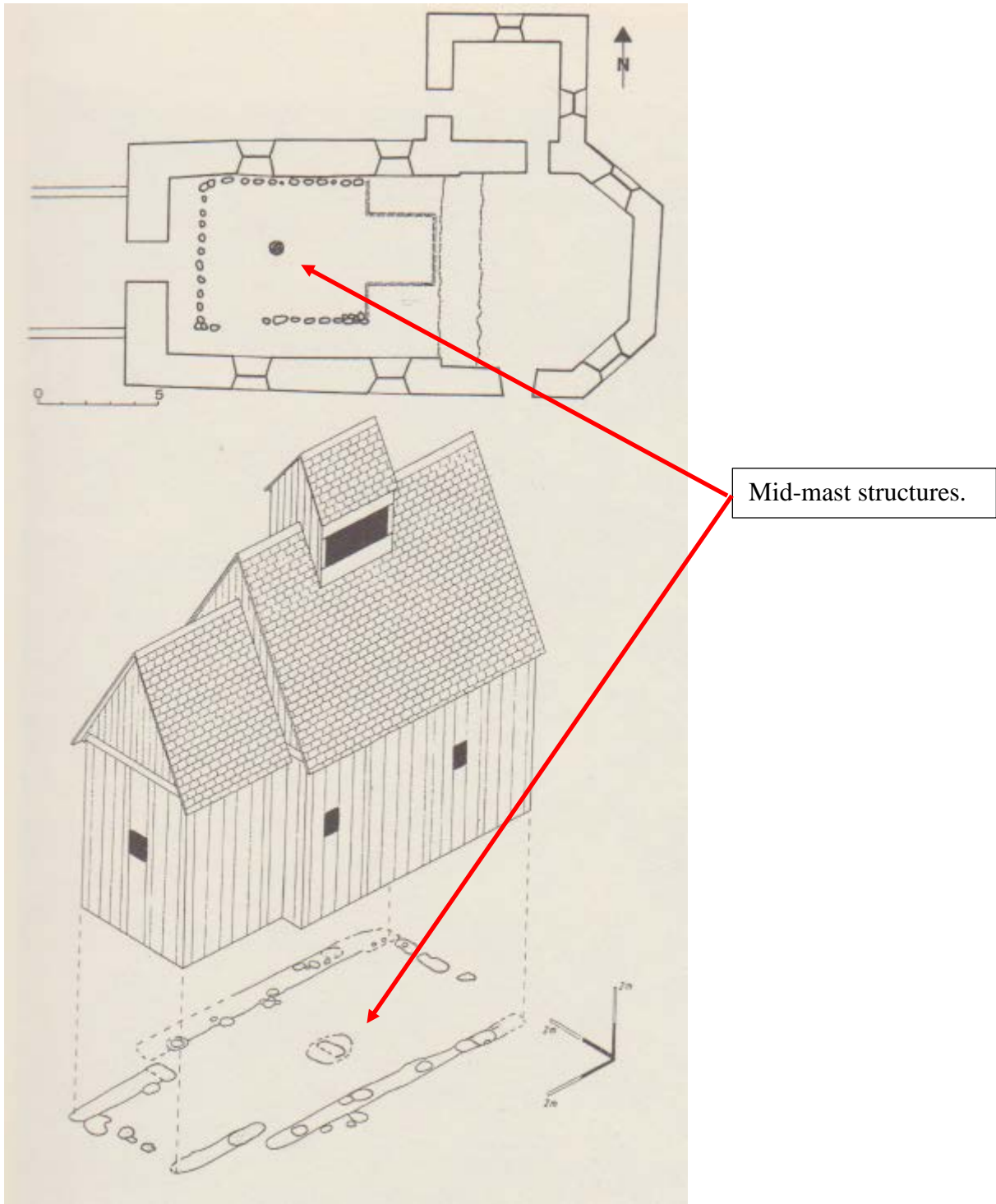
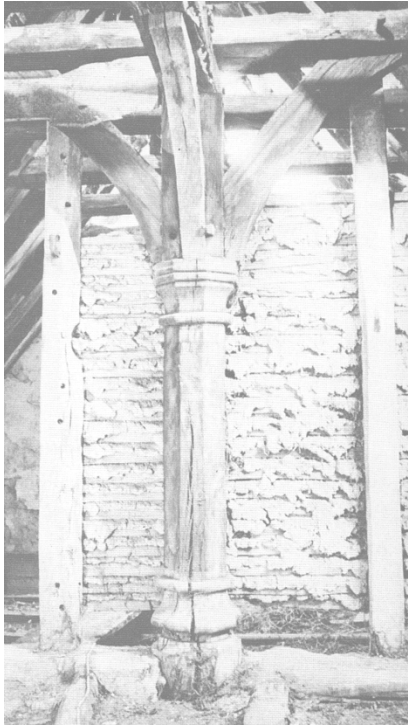
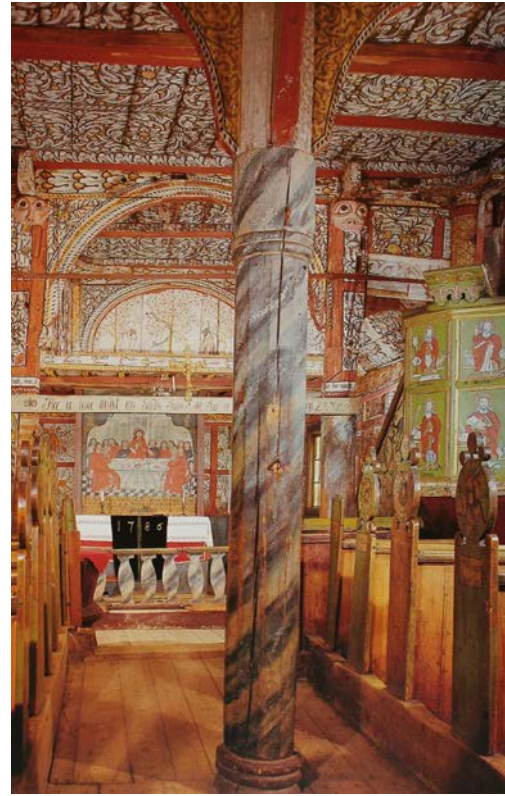

Fig. 85 Examples of Mid-mast structures outside Norway. The church on the top is Mattmar, Sweden, the bottom plan is from Norwich England.
Source: Ahrens 2001: 259.



Medieval Crown Post
(Netherdale, St Nicholas at
Wade, Kent). Source: Harris
2012: Fig 11.



Uvdal Stave Church centre pillar.
Photo source: Valebrokk and Thiis-
Evensen 2001: 50.

Fig. 86 Mid-Mast and Roof supports.



Nore Stave Church. Source: Anker and Havran 2005: 190



Tomb of Galla Placidia, Ravenna c. AD 665. Source: <http://en.wikipedia.org/wiki/Mausoleum_of_Galla_Placidia> [Accessed 03 March 2014].



Uvdal Stave Church. Photo source: Anker and Havran 2005: 200.

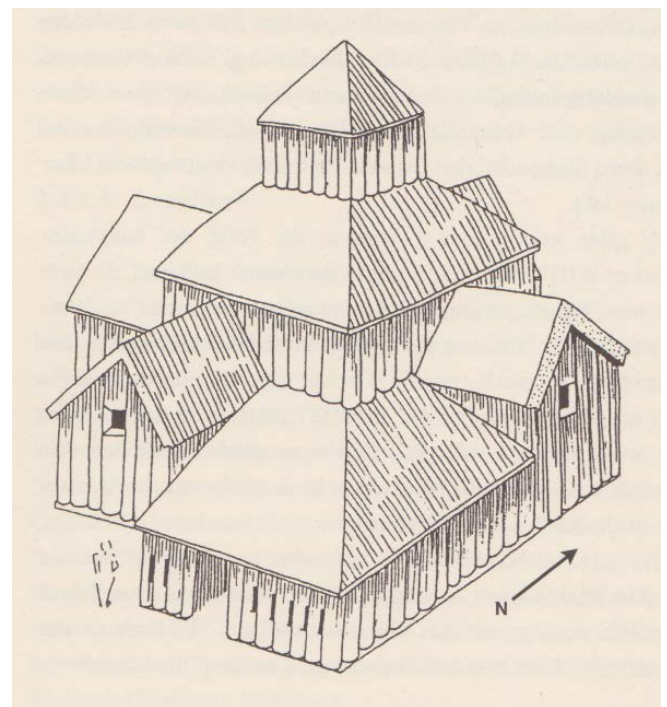

Reconstruction of late 11th-century Potterne Church (Davey 1990: 60).

Fig. 87 Norwegian Equal Arm church comparisons.

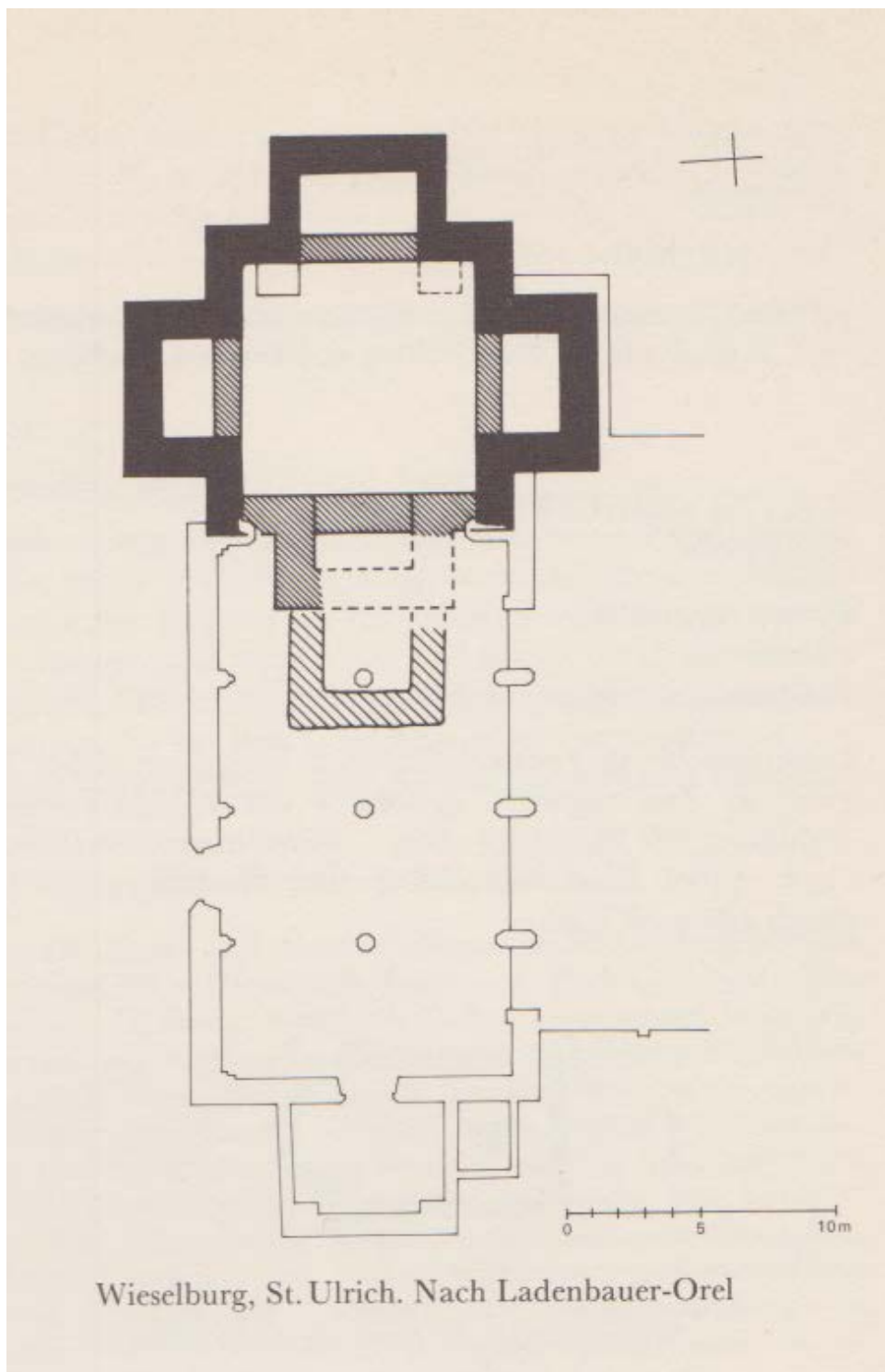

Fig. 88 St. Ulrich, Wieselburg, Lower Austria, Austria 10th century.
Source: Oswald, Schaefer and Sennhauser 1991: 459.

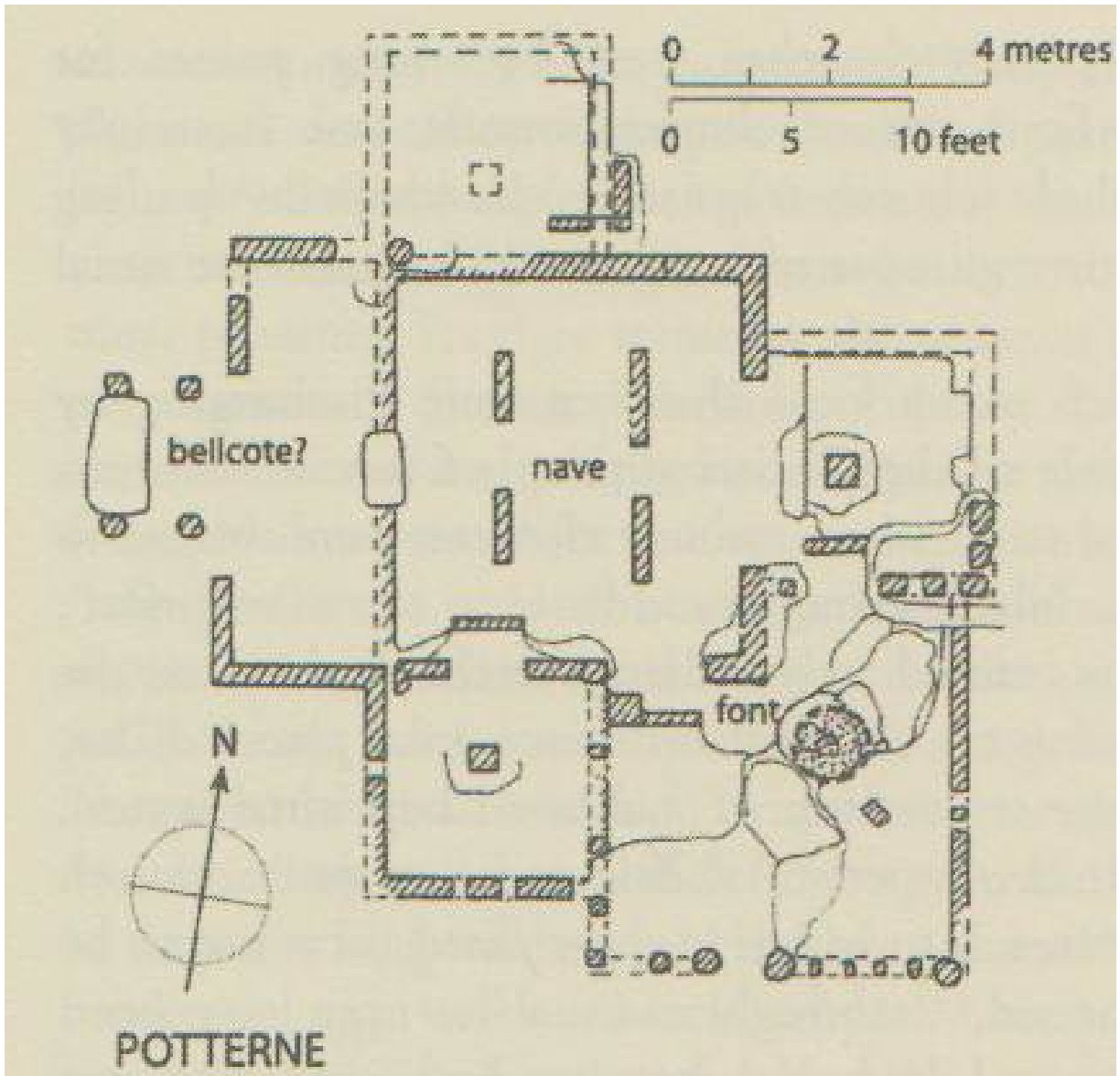

Fig. 89 Late 11th-century timber church in Potterne, Wiltshire. Source: Blair 2010: 460.



Our Lady Church in Kalundborg, Denmark. Source:
 <<http://www.panoramio.com/photo/55573930>>
 [Accessed 05 June 2012]



Kalundborg floor - plan source,
 Toman 2004: 252. Plan is for form
 comparison only, this is not adjusted
 for scale.



Nore floor plan. Source:
 Holan 1990: 119.

Fig. 90 Plan comparisons of Kalundborg and Nore Stave Church.



Fig. 91 Nidaros Cathedral.

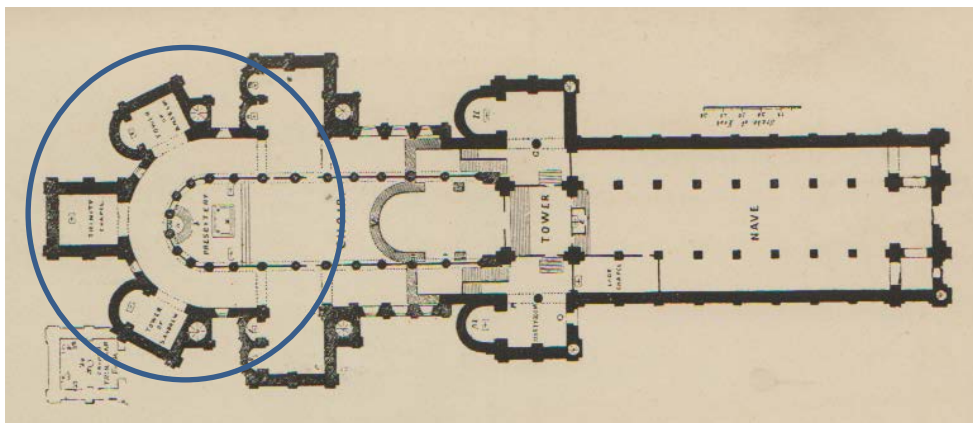
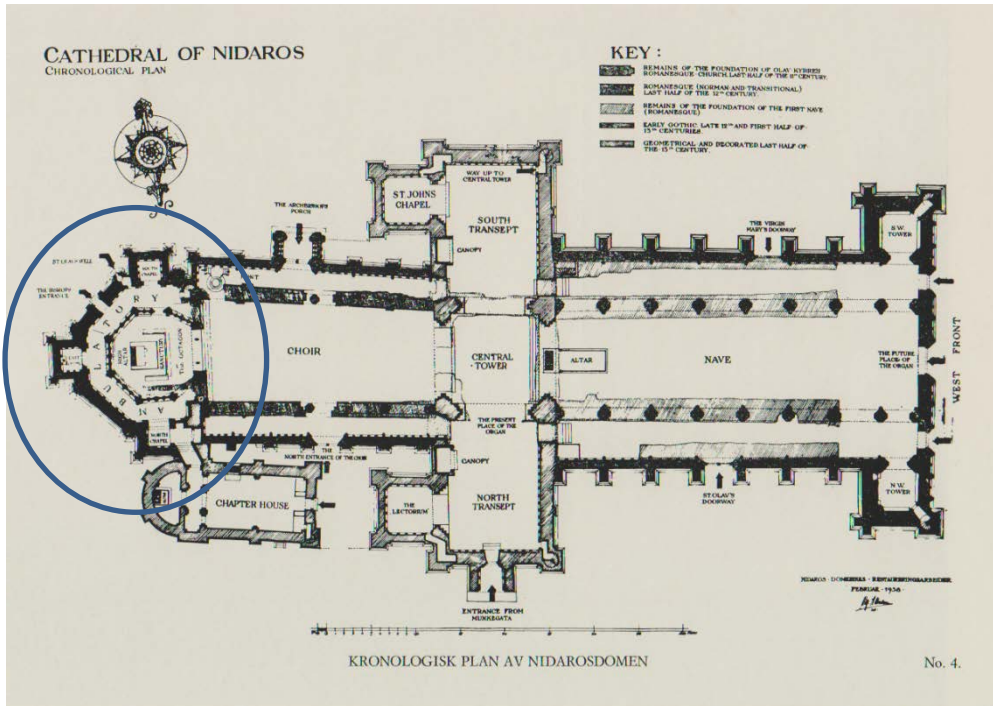

Fig. 92 A comparison of Nidaros and Canterbury Cathedral ground plans. The top image is the floor plan for Nidaros Cathedral (Thiis 1974: Plate 4). The plan on the bottom is Canterbury Cathedral in 1774 (Withers 1899: Plate 2)

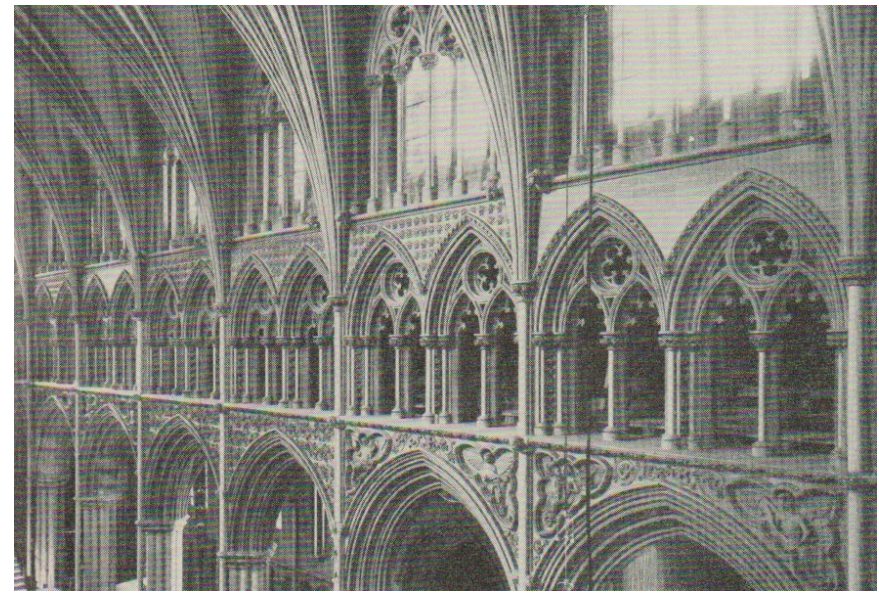
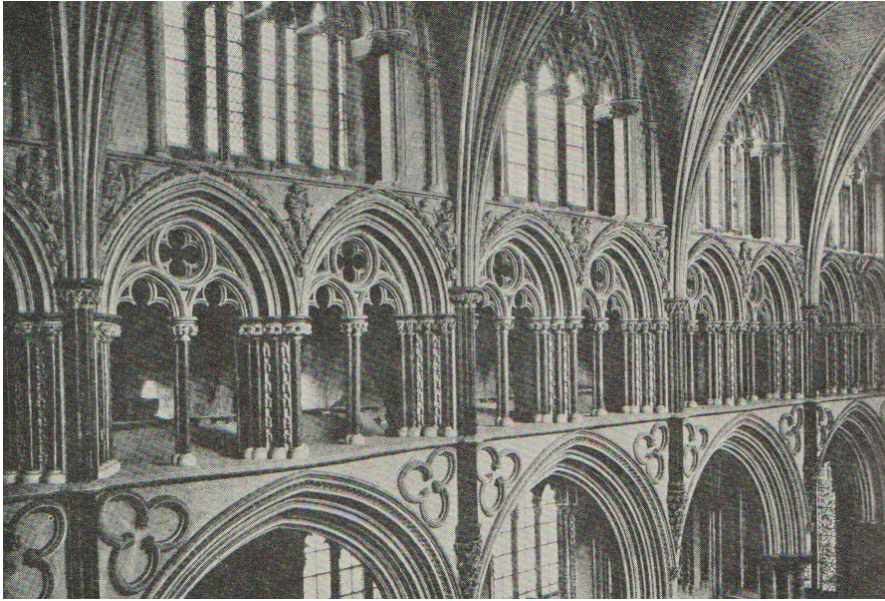

Fig. 93 A comparison of Lincoln and Nidaros choir wall. Image on the left is from Lincoln Cathedral's north choir wall (Fisher 1965: 336). The image on the right is Nidaros Cathedral's south Choir wall (Fischer 1965: 337).

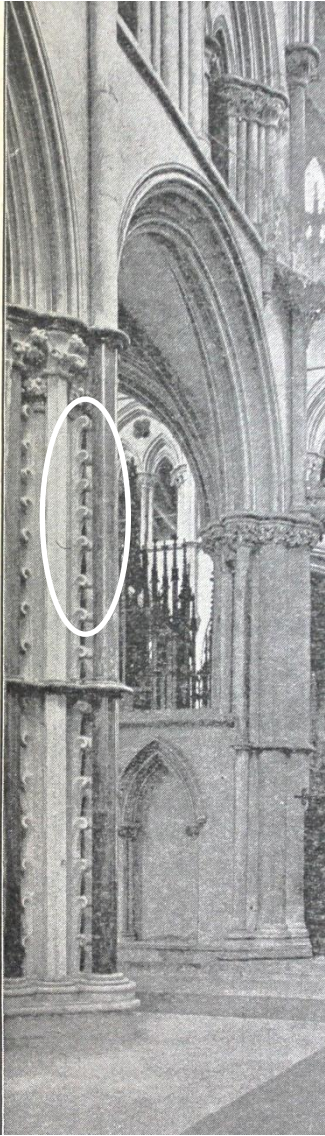

Fig. 94 The Lincoln cathedral 'Nidaros' column (Kendrick 1899: 113) and the Nidaros cathedral 'Lincoln' column (Fischer 1981: 23).



Dragon hood mould Nidaros Cathedral.



Dragon hood mould Lincoln Cathedral.



The Lincoln dragon head has a precise copy in an early twelve century unfinished architectural remnant from Nidaros Cathedral. Source: Blindheim 1966: Figure 31.

Fig. 95 A comparison of hood moulds in Lincoln and Nidaros.



Fig. 96 The original Nidaros Sheila na gig (1150-1180). MET.
A copy is located on the church in the original position.



Fig. 97 Kilpeck Sheila na gig. This carving is contemporaneous to Nidaros (mid to late 12th century). It is located at the Kilpeck Church of St. Mary and St. David (UK). Note that the eyes and face are similar to that of the Sheila na gig at Nidaros. For a comparison point, the an example from Ireland has been included (Source:< <http://homepage.eircom.net/~archaeology/three/sheela.htm> >[Accessed 13 January 2013]



Fig. 98 Resurrection egg from Sigtuna (Uppland, Sweden). HMS Catalog item: SHM 18562.



Church of St. Nicholas (1766), Glotovo, Russia. Built in 1766. Source Brumfield 2004: 508.



Urne Stave Church (1130) Luster, Sogn og Fjordane, Norway.

Fig. 99 Superficial similarities in Russian and Norwegian churches



Fig. 100 External Ambulatory and super structure of the Church of St. Philip and St. Jacob at Sękowa, Poland. Although the external ambulatory shares similarities with the Norwegian example, there are differences. The eastern ambulatories usually (although there are exceptions) go around only three sides of the church. There is also the issue of the horizontal wall construction. This building style (called blockbau) is common in Eastern traditions but not in medieval Norwegian ones. The roof and superstructure are also different.



Fig. 101 Icon of Saint Alexander of Oshevensk. This icon (there are several extant, and they are still produced) is believed to show the Aleksandro-Oshevenskii Monastery as it existed in the 15th century (Khodakovskiy 2016: 11-2). Image source: <<http://www.skete.com/images/products/icons/CS1158lg.jpg>> [Accessed 01 August 2017]

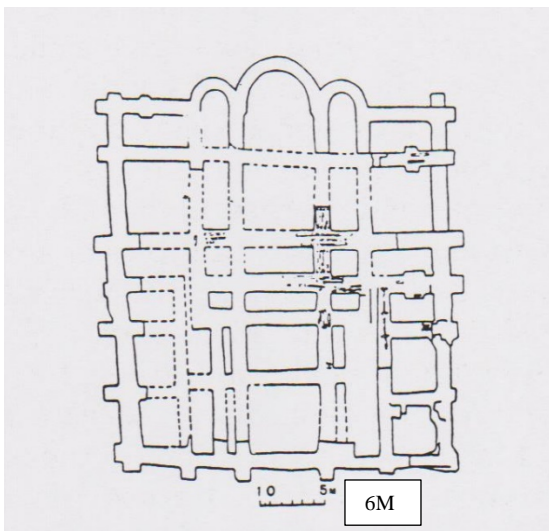
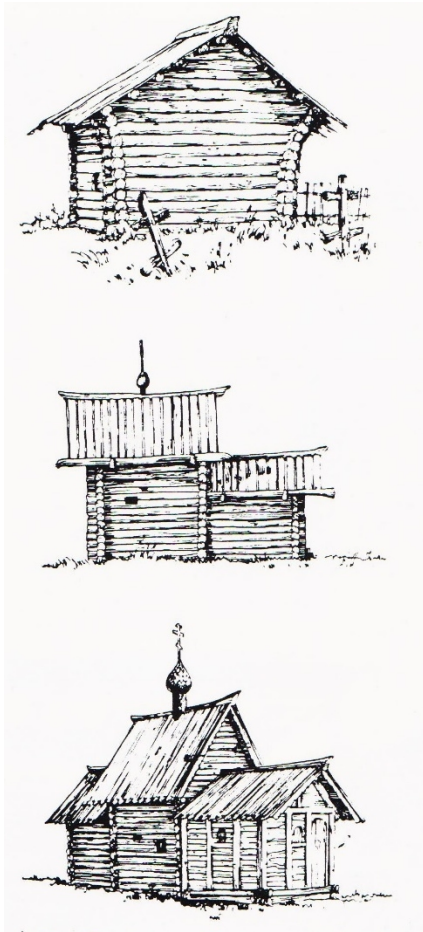

Fig. 102 Ground plans of the Church of the Tithe, Kiev c. 989-996. Plan reconstruction by Mikhail Karger. Source: Brumfield 2004: 11.

Typology of Russian Timber Churches (from our target time frame).

Klet



The images from top to bottom are: Yukko-Guba (viewed from the east), Akhpoila (view from the south) and St. Lazarus (from the north-west). Photo source: Buxton 1981: 39

Shater



This is the form at its most basic. The square structure can be seen under the octagonal tower. The pyramidal roof and its flat sections can be clearly seen. This is St Demetrius of Salonica, Verkhnyaya Uftyuga, Russia . Photo source: Brumfield 2004: 194.

Other Types (later than the thirteenth century).

Kub

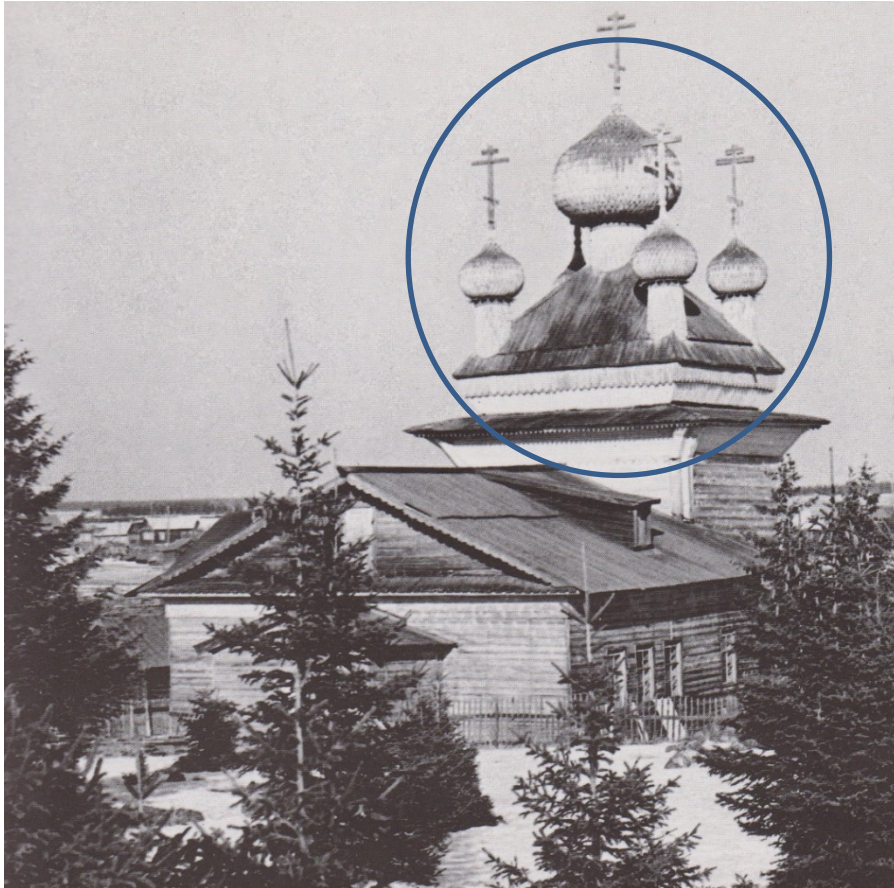

A tetrahedral roof on a rectangular base. It can be visualized as a large onion dome, on a pyramidal base. Mid-18th century Church of St. Peter and Paul, Virma (Karelia, Russia). Photo source: Opolovnikova and Opolovnikova 1989: 237.

Combined: Tiered and Many Domed Style

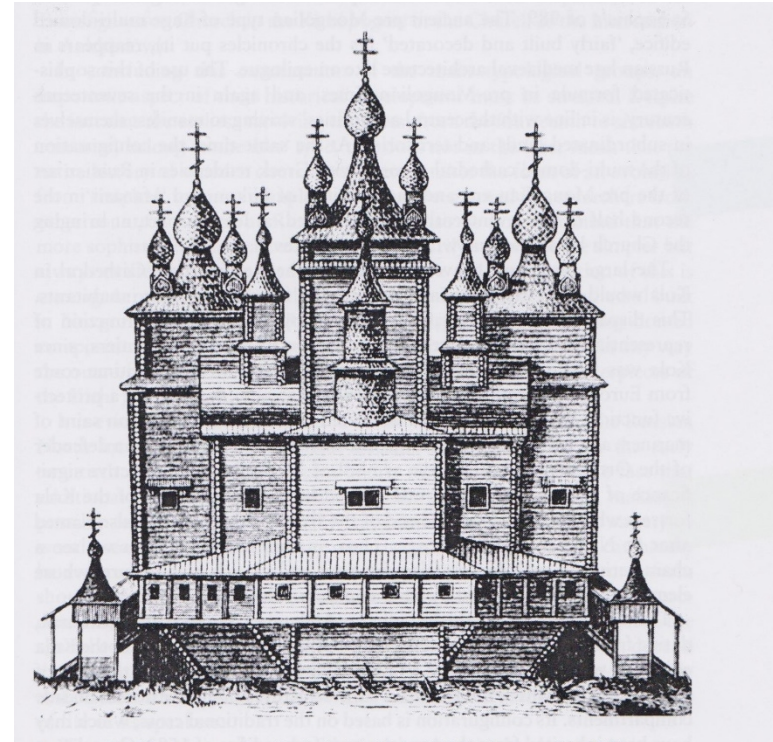

This church combines the Tiered (layered) structure, with Many-Domes. Both styles occur centuries out of our target time frame, showing up in the late 17th century. For the sake of completeness we include this example. This is the Resurrection Cathedral in Kola (Russia), built in 1684. Photo source: Khodavosky 2016: 79

Fig. 103 Typologies of Russian Timber Churches.



Plan Source: Opolovnikov and Opolovnikova 1989: 164. The blue line is five meter scale.

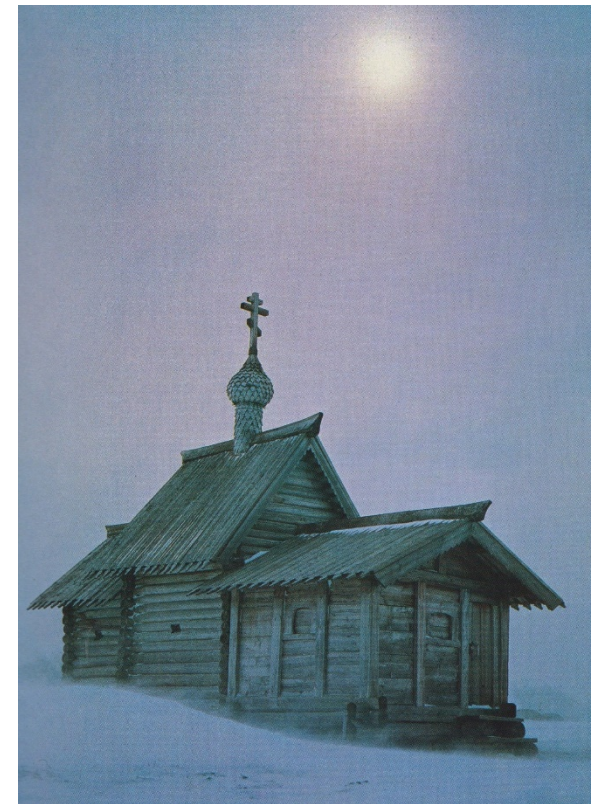
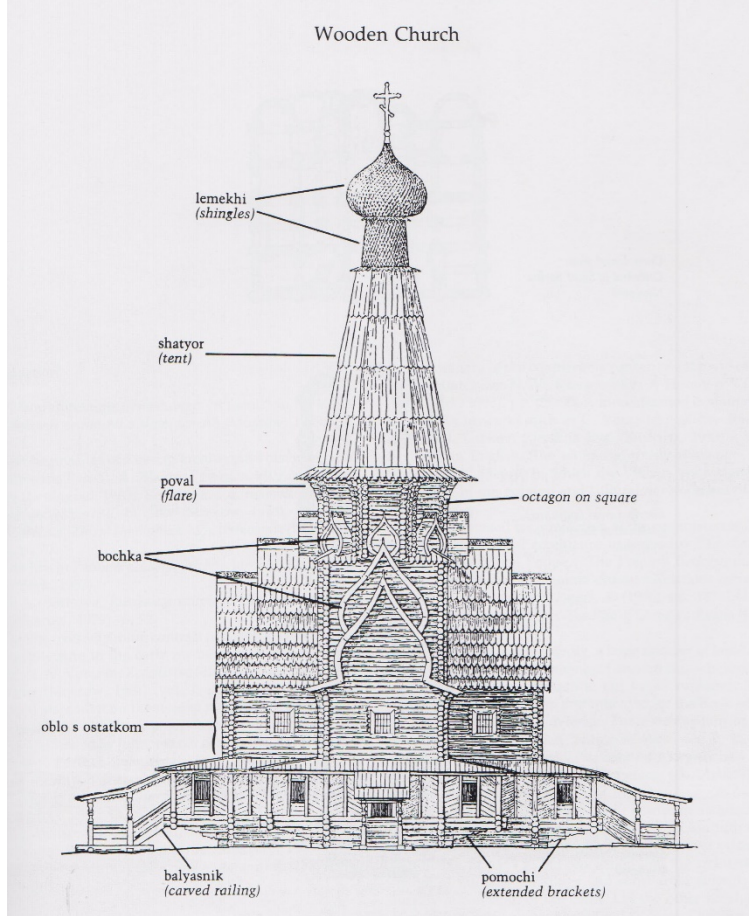

Photo source: Opolovnikov and Opolovnikova 1989: Plate XV

Fig. 104 . The Church of the Resurrection of Lazarus, Kizhi Island, Karelia

5M

Both plans share the same scale and are aligned West (left) to East.



Church of the Presentation (1684), Osinovo, Arkhangelsk, Russia. Source: Brumfield 2004: 525.

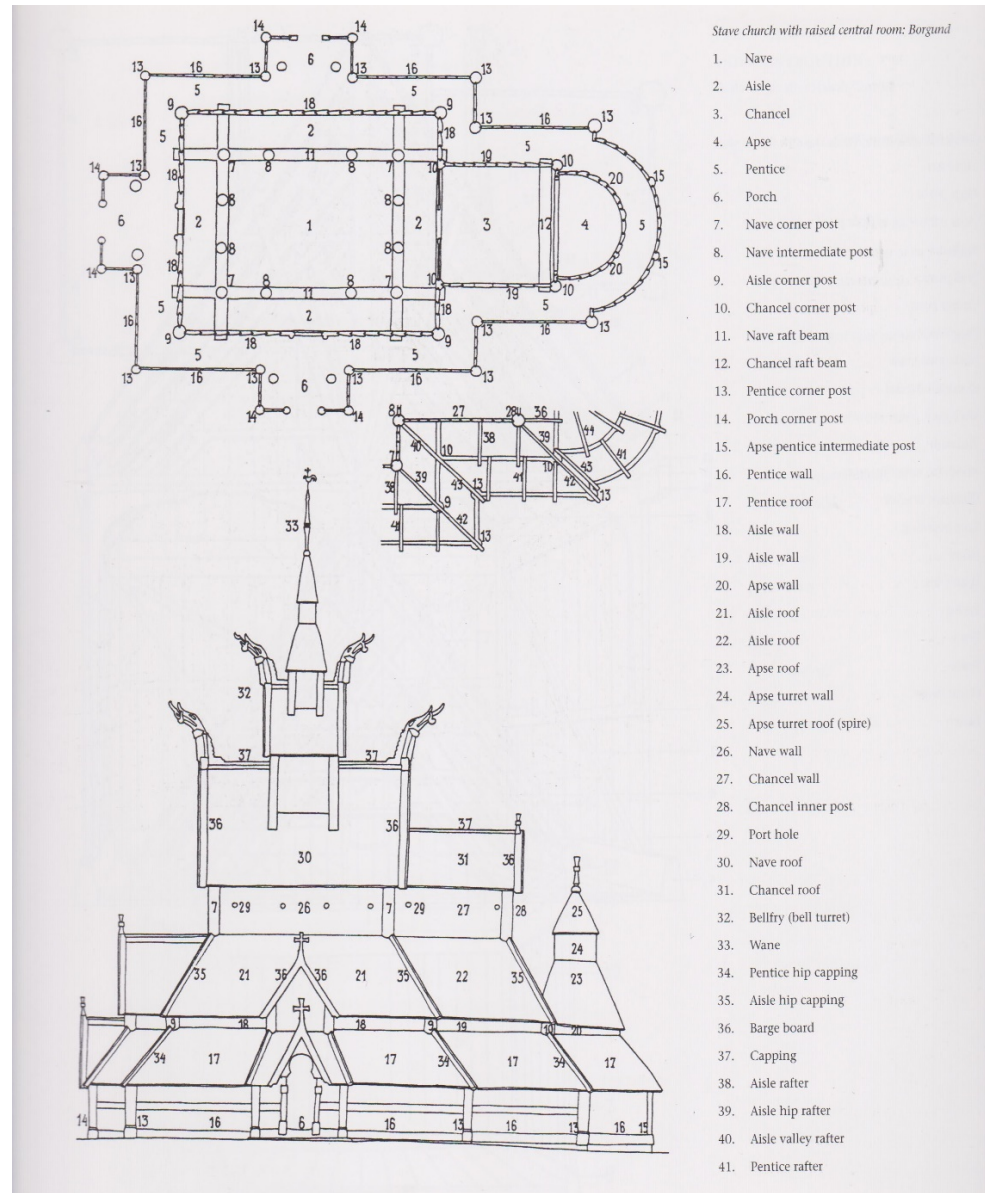

Borgund Stave Church (1180), Lærdal, Sogn og Fjordane, Norway. Ankar and Havran 2005a: 340.

Fig. 105 Russian and Norwegian plan comparison



Odin Stone, from Hustad Church, Nord-Trøndelag, Norway. Source: Walaker Nordeide 2011: 39.



This c. 10th century Icelandic 'Wolf head' Thors Hammer combines pagan and Christian imagery. THB

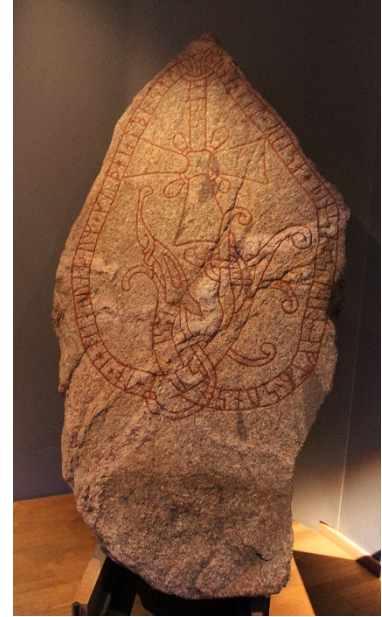

It is not unusual to have a mix of pagan and Christian symbology. Unna's Rune Stone, Torsätra, Uppland, Sweden (Rundata U 613) has both extensive dragon imagery, with a cross and Christian inscription. HMS

Skog church wall hanging (Hälsingland, Sweden). This provides a good example of the difficulties in interpretation.



This imagery has been interpreted differently depending on your point of view. It may represent Thor, Odin and Frey or, it may represent St. Olaf, Knut and Erik. It is worth noting that the animals are moving away from these three figures.



This is quite clearly a two cell stave church.

Fig. 106 Artefacts that may demonstrate syncretic beliefs.