

## Durham E-Theses

---

### *Biopolymer Stabilised Earthen Construction Materials*

SRAVAN MUGUDA-VISWANATH

#### How to cite:

---

MUGUDA-VISWANATH, SRAVAN (2019) Biopolymer Stabilised Earthen Construction Materials. Doctoral thesis, Durham University.

#### Use policy

---

The full-text may be used and/or reproduced, and given to third parties in any format or medium, without prior permission or charge, for personal research or study, educational, or not-for-profit purposes provided that:

- a full bibliographic reference is made to the original source
- a <https://etheses.durham.ac.uk/id/eprint/13444/> is made to the metadata record in Durham E-Theses
- the full-text is not changed in any way

The full-text must not be sold in any format or medium without the formal permission of the copyright holders.

Please consult the [full Durham E-Theses policy](#) for further details.

# Biopolymer Stabilised Earthen Construction Materials

Thesis by

Sravan Muguda Viswanath

Submitted as partial consideration towards  
the degree of Doctor of Philosophy



Department of Engineering  
Durham University  
United Kingdom



ISA BTP - SIAME  
University of Pau and Pays de l'Adour  
France

September 2019

# Abstract

Earthen structures (i.e. structural units manufactured from soil) are often regarded as sustainable forms of construction due to their characteristically low carbon footprint. Unstabilised earthen construction materials have low embodied energy, excellent hygroscopic properties and recycling potential. However, in this form, the material is susceptible to deterioration against water ingress and most modern earthen construction materials rely on cement to improve their durability properties. Using cement leads to compromises in hygroscopic properties and recyclability potential. In this situation, it is imperative to look for alternatives to cement, which can address these issues without compromising on the desired engineering properties of these materials. This thesis explores the use of biopolymers, namely guar and xanthan gum, as stabilisers for earthen construction materials. As an initial step, an experimental campaign was undertaken to understand biopolymer stabilisation and optimise their use to stabilise earthen construction materials. The results from this campaign reveal that biopolymer stabilised soils derive their strength through a combination of soil suction and hydrogel formation. The intrinsic chemical properties of the biopolymer affect the nature of hydrogel formation and in turn strength. In a subsequent campaign of experimental work, hydraulic and mechanical properties of these biopolymer stabilised soils were determined. The hydraulic properties of the biopolymer stabilised soils indicate that for the range of water contents, the suction values of biopolymer stabilised soils are higher than unamended soils. The soil water retention curves suggest that both biopolymers have increased the air entry value of the soil while affecting the void size distribution. Shear strength parameters of biopolymer stabilised soils were obtained through constant water triaxial tests, and it was noted that both biopolymers have a significant and yet different effect on soil cohesion and internal friction angle. With time, guar gum stabilised soils derive strength through the frictional component of the soil strength, while xanthan gum stabilised soil strength has a noticeable contribution from soil cohesion. Macrostructural analysis in the form of X-RCT scans indicate that both biopolymers form soil agglomerations and increase overall porosity. The void size distribution curves obtained from XRCT scanning complement the findings of the suction tests. As a final study, the performance of biopolymer stabilised earthen construction materials was assessed as a building material. Durability performance of these materials against water ingress was evaluated, and it was noted both biopolymers provide satisfactory stabilisation to improve the erosional resistance of the material. In conclusion, unlike cement, biopolymer stabilised earthen materials do not compromise on hygroscopic properties and have better mechanical performance than unamended earthen construction materials. Finally, recyclability tests suggest that apart from improving the strength, durability and hygroscopic properties of the material, biopolymer stabilised earthen construction materials have a better potential for recycling without any environmental concerns.

# Résumé

Les constructions en terre crue, soit fabriquées à partir de sol, sont considérées comme des constructions durables en raison de leur faible empreinte environnementale : les matériaux de construction à base de terre crue non stabilisée ont une faible énergie intrinsèque, d'excellentes propriétés hygroscopiques et un fort potentiel de recyclage. Cependant, sous cette forme, les matériaux sont susceptibles de se détériorer au contact de l'eau. Ainsi, les éléments de constructions modernes en terre crue utilisent du ciment pour améliorer leur durabilité, mais entachent de ce fait leurs propriétés hygroscopiques et leur potentiel de recyclable. Il est donc impératif de développer des solutions alternatives à l'incorporation de ciment, pouvant améliorer la résistance à l'eau sans pour autant compromettre les propriétés qui constituent les atouts de ces matériaux durables. Ces travaux de doctorat étudient l'utilisation de deux biopolymères, la gomme de guar et le xanthane, comme stabilisants naturels pour les matériaux de construction en terre crue. Dans un premier temps, une campagne expérimentale a été menée pour comprendre le mécanisme de stabilisation de la terre par ces biopolymères et optimiser cette technique. Les résultats révèlent que la nature intrinsèque des biopolymères induit la formation d'hydrogels qui participent à renforcer le matériau et à modifier les phénomènes de succion. L'addition d'environ 2,0 % de biopolymère en masse de sol sec est suffisant pour obtenir un comportement mécanique comparable à la stabilisation au ciment à un taux de 8,0 %. Afin de mieux caractériser l'influence des biopolymères, les propriétés hydrauliques et mécaniques des sols ainsi stabilisés ont été étudiées. Les tests de caractérisation prouvent que, pour une même gamme de teneur en eau, la succion des sols stabilisés par les biopolymères est supérieure à celle des sols non stabilisés. Les courbes de rétention d'eau sol démontrent que la valeur d'entrée d'air est augmentée en présence des biopolymères, ce qui affecte la distribution de la taille des vides. Les paramètres de résistance au cisaillement ont été obtenus par des essais triaxiaux à teneur d'eau constante. Les deux biopolymères ont un effet significatif, et pourtant différent, sur la cohésion du sol et l'angle de friction interne. Dans le temps, la modification de résistance des sols stabilisés à la gomme de guar est liée à la variation de la composante de friction, tandis que pour les sols stabilisés à la gomme de xanthane cette variation est pilotée par la cohésion du sol. L'analyse microstructurale par micro tomographie X-RCT montre que les biopolymères favorisent l'agglomération des particules de sol, ce qui modifie la porosité globale. Les courbes de distribution de la taille des vides obtenues par balayage XRCT confirment les résultats des essais de succion. Pour finir, les performances en termes de durabilité de ces matériaux de construction stabilisés aux biopolymères en présence d'eau ont été validées par différents tests ainsi que leur potentiel de recyclage. Il apparaît donc que l'utilisation de ces biopolymères comme stabilisant améliore la résistance mécanique des matériaux en terre crue et leur durabilité ; et que contrairement à la stabilisation au ciment le comportement hygroscopique est conservé - voire amélioré-, ainsi que le potentiel de recyclage.

# Declaration

The work in this thesis is based on research carried out in the Sustainable Infrastructure group, Department of Engineering, Durham University, United Kingdom and SIAME laboratory, University of Pau and Pays de l' Adour, France. No part of this report has been submitted elsewhere for any other degree or qualification and it all my own work unless referenced to the contrary in the text.

Copyright © 2019 by Sravan Muguda Viswanath.

"The copyright of this thesis rests with the author. No quotations from it should be published without the authors prior written consent and information derived from it should be acknowledged."

अनन्याश्चिन्तयन्तो मां ये जनाः पर्युपासते  
तेषां नित्याभियुक्तानां योगक्षेमं वहाम्यहम् ॥ २२ ॥

*ananyāś cintayanto mām  
ye janāḥ paryupāsate  
teṣāṃ nityābhīyuktānām  
yoga-kṣemaṃ vahāmy aham*

But those who always worship Me with exclusive devotion, meditating on My transcendental form—to them I carry what they lack, and I preserve what they have.

*Dedicated to my spiritual master HH Jayapataka Swami Maharaj*

# Table of Contents

|  |     |
|--|-----|
| Abstract .....   | i   |
| Résumé.....  | ii  |
| Declaration.....   | iii |
| Acknowledgements .....   | ix  |
| Publications.....  | x   |
| Nomenclature .....   | xi  |
| Chapter 1 Introduction.....  | 1   |
| 1.1 “Earth” as a building material.....  | 1   |
| 1.2 Revival of earthen construction.....   | 1   |
| 1.3 Earthen materials – Modern perspective.....                                    | 4   |
| 1.3.1 Problems with modern earthen construction .....                              | 6   |
| 1.4 Research aims and objectives.....  | 7   |
| 1.5 Thesis structure .....   | 8   |
| References .....   | 9   |
| Chapter 2 Literature Review .....  | 11  |
| 2.1 Chapter introduction.....  | 11  |
| 2.2 Earthen construction techniques .....  | 11  |
| 2.2.1 Rammed earth wall construction .....   | 11  |
| 2.2.1.1. Overview of rammed earth construction.....                                | 11  |
| 2.2.1.2. Construction procedure for a rammed earth wall.....                       | 14  |
| 2.2.2 Compressed earth blocks .....  | 15  |
| 2.2.2.1. Overview of compressed earth blocks .....                                 | 15  |
| 2.2.2.2. Manufacturing procedure for compressed earth blocks.....                  | 16  |
| 2.2.3 Suitable soils for earthen materials .....                                   | 17  |
| 2.2.3.1. Particle size distribution .....  | 17  |
| 2.2.3.2. Plasticity and Shrinkage properties of earthen construction material..... | 19  |
| a) Clay mineralogy .....   | 19  |
| b) Plasticity properties of earthen construction material .....                    | 21  |
| c) Shrinkage properties of earthen material.....                                   | 22  |
| 2.2.4 Desired engineering properties of earthen material.....                      | 23  |
| 2.2.4.1. Strength characteristics of earthen material.....                         | 24  |
| 2.2.4.2. Durability characteristics of earthen material.....                       | 28  |
| 2.2.4.3. Hygroscopic characteristics of earthen material.....                      | 30  |
| 2.2.4.4. Recyclability potential of earthen material.....                          | 32  |

|          |  |    |
|----------|--|----|
| 2.3      | Role of unsaturated soil mechanics in earthen materials .....                                | 33 |
| 2.3.1    | Phase relationships .....  | 33 |
| 2.3.2    | Strength of soils .....  | 34 |
| 2.3.3    | Suction in unsaturated soils.....  | 35 |
| 2.3.3.1. | Matric suction .....   | 35 |
| 2.3.3.2. | Osmotic suction.....   | 36 |
| 2.3.3.3. | Total suction.....   | 36 |
| 2.3.4    | Soil-water retention curve .....   | 36 |
| 2.3.5    | Role of soil suction in earthen construction materials .....                                 | 39 |
| 2.4      | Bio-stabilisation techniques .....   | 43 |
| 2.4.1    | Bio-stabilisation of soils .....   | 43 |
| 2.4.2    | Biopolymer soil stabilisation.....   | 44 |
| 2.4.3    | Biopolymer stabilisation in geotechnical engineering.....                                    | 45 |
| 2.4.3.1. | Guar Gum .....   | 46 |
| 2.4.3.2. | Xanthan Gum.....   | 47 |
| 2.4.3.3. | Effect of biopolymer stabilisation on different soil properties .....                        | 47 |
| 2.4.3.4. | Summary of biopolymer soil stabilisation .....   | 53 |
| 2.4.4    | Biopolymer soil stabilisation for earthen construction materials.....                        | 53 |
| 2.5      | Concluding remarks .....   | 54 |
|          | References .....   | 55 |
|          | Chapter 3 Biopolymer Stabilisation .....   | 61 |
| 3.1      | Introduction .....   | 61 |
| 3.2      | Materials.....   | 61 |
| 3.2.1    | Engineered soil mixture .....  | 61 |
| 3.2.2    | Biopolymers.....   | 64 |
| 3.2.3    | Cement .....   | 65 |
| 3.3      | Experimental programme.....  | 65 |
| 3.3.1    | Effect of biopolymers on plasticity and shrinkage properties of the soil mix..               | 65 |
| 3.3.1.1. | Methodology .....  | 65 |
| 3.3.1.2. | Test results .....   | 65 |
| 3.3.2    | Strength characteristics of biopolymer stabilised earthen construction materials.....        | 68 |
| 3.3.2.1. | Unconfined compressive strength of biopolymer stabilised earthen construction materials..... | 68 |
| 3.3.2.2. | Tensile strength of biopolymer stabilised earthen construction materials.....                | 74 |

|   |     |
|---|-----|
| 3.3.2.3. Discussion on strength test results .....  | 77  |
| 3.3.3 Synergistic behaviour of biopolymers .....  | 81  |
| 3.3.3.1. Plasticity and shrinkage characteristics .....   | 81  |
| 3.3.3.2. Strength characteristics.....  | 83  |
| 3.3.4 Macrostructural investigation through X-Ray computed tomography.....                          | 84  |
| 3.3.4.1. X-Ray computed tomography.....   | 84  |
| 3.3.4.2. Sample preparation and scanning.....   | 86  |
| 3.3.4.3. Qualitative analysis.....  | 87  |
| 3.3.5 Preliminary durability tests.....   | 88  |
| 3.3.5.1. Sample preparation and testing methodology .....   | 88  |
| 3.3.5.2. Test results .....   | 89  |
| 3.4 Concluding remarks .....  | 90  |
| References .....  | 92  |
| Chapter 4 Geotechnical characterisation of biopolymer stabilised earthen construction material..... | 95  |
| 4.1 Chapter Introduction .....  | 95  |
| 4.2 Shear Strength of Unsaturated soils.....  | 95  |
| 4.3 Experimental Programme .....  | 97  |
| 4.4 Suction tests.....  | 98  |
| 4.4.1 Testing methodology .....   | 98  |
| 4.4.2 Test results.....   | 99  |
| 4.4.2.1. Suction test results .....   | 99  |
| 4.4.2.2. Soil water retention curve .....   | 103 |
| 4.4.2.3. Scanning curve.....  | 107 |
| 4.5 Constant water content triaxial tests .....   | 109 |
| 4.5.1 Testing methodology .....   | 109 |
| Figure 4.14. Typical setup for triaxial test .....  | 110 |
| 4.5.2 Stress – strain relationship.....   | 111 |
| 4.5.3 Determination of shear strength parameters .....  | 115 |
| 4.5.4 Strength characteristics of engineered soil mix.....  | 120 |
| 4.6. Macrostructural investigation using X-ray computed tomography .....                            | 125 |
| 4.6.1 Specimen Preparation .....  | 125 |
| 4.6.2 Test results.....   | 127 |
| 4.6.2.1. X-RCT scans .....  | 127 |
| 4.6.2.2. Porosity and void size distribution curves.....  | 131 |

|   |     |
|---|-----|
| Table 4.7. Porosity for all samples at different curing periods. ....                                   | 131 |
| 4.7. Concluding remarks .....   | 134 |
| References .....  | 137 |
| Chapter 5 Assessment of biopolymer stabilised earthen construction material as a building material..... | 139 |
| 5.1 Chapter Introduction .....  | 139 |
| 5.2 Sample preparation.....   | 139 |
| 5.2.1 Materials.....  | 139 |
| 5.2.2 Sample preparation.....   | 140 |
| 5.2.2.1. Small cylindrical specimens.....   | 141 |
| 5.2.2.2. Tile specimens.....  | 141 |
| 5.2.2.3. Large cylindrical samples.....   | 142 |
| 5.2.2.4. Brick samples .....  | 142 |
| 5.3 Durability tests .....  | 145 |
| 5.3.1. Rainfall induced erosional tests .....   | 146 |
| 5.3.1.1. Testing methodology.....   | 146 |
| 5.3.1.2. Results and discussion .....   | 148 |
| 5.3.2. Contact tests .....  | 150 |
| 5.3.2.1. Test procedure.....  | 151 |
| 5.3.2.2. Test results .....   | 151 |
| 5.3.3. Suction tests.....   | 152 |
| 5.3.3.1. Test procedure.....  | 152 |
| 5.3.3.2. Test results .....   | 154 |
| 5.3.4. Dip tests .....  | 154 |
| 5.3.4.1. Test procedure.....  | 154 |
| 5.3.4.2. Test results .....   | 155 |
| 5.3.5. Discussion on durability tests.....  | 156 |
| 5.4 Hygroscopic behaviour of earthen construction materials.....  | 158 |
| 5.4.1. Test methodology .....   | 158 |
| 5.4.2. Test results.....  | 160 |
| 5.4.2.1. Moisture absorption curves.....  | 160 |
| 5.4.2.2. Moisture buffering value .....   | 162 |
| 5.5 Recyclability potential of earthen construction materials. ....                                     | 166 |
| 5.5.1. Materials.....   | 166 |
| 5.5.2. Recycling Procedure .....  | 167 |

|          |  |     |
|----------|--|-----|
| 5.5.3.   | Test method and results.....   | 167 |
| 5.5.3.1. | Particle size analysis.....  | 167 |
| 5.5.3.2. | Atterberg limits and Linear Shrinkage tests.....                       | 168 |
| 5.5.3.3. | Chemical tests on water.....   | 170 |
| 5.5.4.   | Discussion on test results.....  | 171 |
| 5.6.     | Concluding remarks.....  | 172 |
|          | References.....  | 174 |
|          | Chapter 6 Conclusions.....   | 176 |
| 6.1      | Chapter introduction.....  | 176 |
| 6.2      | Research highlights.....   | 176 |
| 6.2.1    | Biopolymer stabilisation.....  | 176 |
| 6.2.2    | Geotechnical characterisation.....                                     | 177 |
| 6.2.2.1. | Suction tests.....   | 177 |
| 6.2.2.2. | Triaxial tests.....  | 178 |
| 6.2.2.3. | Macrostructure analysis.....   | 179 |
| 6.2.3    | Assessment as building material.....                                   | 179 |
| 6.2.3.1. | Durability tests.....  | 179 |
| 6.2.3.2. | Hygroscopic behaviour.....   | 180 |
| 6.2.3.3. | Recycling potential.....   | 180 |
| 6.3      | Implications of biopolymer stabilisation.....                          | 180 |
| 6.3.1    | In geotechnical engineering.....                                       | 180 |
| 6.3.2    | Application in earthen building construction.....                      | 181 |
| 6.4      | Potential future research work.....                                    | 182 |
| 6.4.1    | Microstructure analysis.....   | 182 |
| 6.4.2    | Durability tests.....  | 182 |
| 6.4.3    | Life cycle assessment for biopolymer stabilised earthen materials..... | 183 |
| 6.4.4    | Field Implementation.....  | 183 |
| 6.5      | Concluding remarks.....  | 184 |
|          | References.....  | 185 |
|          | Appendix.....  | 186 |

## List of Tables

|   |     |
|---|-----|
| Chapter 2 Literature Review .....   | 11  |
| Table 2.1. Theoretical manufacturing output of CEBs (Rigassi, 1985).....  | 17  |
| Table 2.2. Recommended soil proportions for unstabilised earthen materials.....   | 19  |
| Table 2.3. Recommended soil proportions for cement stabilised earthen materials .....   | 20  |
| Table 2.4. Recommended plasticity properties for cement stabilised earthen materials .....  | 22  |
| Table 2.5. Design and characteristic compressive strength for compressed earth blocks as per different national regulations.....                | 27  |
| Table 2.6. Design and characteristic compressive strength for rammed earth as per different national regulations .....                          | 27  |
| Table 2.7. Recommended durability tests in practice in different countries.....   | 29  |
| Chapter 3 Biopolymer Stabilisation .....  | 61  |
| Table 3.1. Physical properties of the unstabilised soil mixture. ....   | 64  |
| Table 3.2. Physical properties of biopolymers used (Intralabs, 2016a, 2016b).....   | 65  |
| Table 3.3. Different proportions of biopolymer used in this study. ....   | 69  |
| Table 3.4. Tensile to unconfined compressive strength ratios.....   | 80  |
| Table 3.5. Synergistic combinations of biopolymer used in this study.....   | 81  |
| Table 3.6. Atterberg limits and linear shrinkage values.....  | 82  |
| Table 3.7. Tests results of preliminary durability tests.....   | 90  |
| Chapter 4 Geotechnical characterisation of biopolymer stabilised earthen construction material.....   | 95  |
| Table 4.1. Soil Modulus at different curing periods.....  | 111 |
| Table 4.2. Shear strength parameters, total suction and water content values for unamended soil specimens .....                                 | 116 |
| Table 4.3. Shear strength parameters, total suction and water content values of guar gum stabilised soil specimens.....                         | 117 |
| Table 4.4. Shear strength parameters, total suction and water content values for xanthan gum stabilised soil specimens .....                    | 118 |
| Table 4.5. Shear strength parameters, total suction and water content values for xanthan gum stabilised soil specimens .....                    | 123 |
| Table 4.6. Comparison of shear strength parameters of different earthen construction materials from literature and data from present study..... | 124 |
| Table 4.7. Porosity for all samples at different curing periods. ....   | 131 |
| Chapter 5 Assessment of biopolymer stabilised earthen construction material as a building material.....   | 139 |
| Table 5.1. Different sample configurations considered in this assessment.....   | 140 |

|   |     |
|---|-----|
| Table 5.2. Classification of earthen construction material as per NZS 4298 (1998) ...         | 146 |
| Table 5.3. Classification of compressed earth blocks as per DIN 18945 (2013). .....           | 157 |
| Table 5.4. Classification of earthen construction materials as per DIN 18945 (2013).<br>..... | 157 |
| Table 5.5. Results for the chemical tests of water.....                                       | 171 |

## List of Figures

|   |    |
|---|----|
| Chapter 2 Literature Review .....   | 11 |
| Figure 2.1. Rammed earth portion of The Great Wall of China at Gansu, China. Photo retrieved from <a href="https://www.murailledechine.com/voyage-jiayuguan-gansu">https://www.murailledechine.com/voyage-jiayuguan-gansu</a> ..... | 12 |
| Figure 2.2. Chapel of Reconciliation in Berlin, Germany, Photo by Reitermann (2001) .....   | 13 |
| Figure 2.3. Illustration of rammed earth wall construction .....  | 15 |
| Figure 2.4. Illustration of manufacturing compressed earth blocks .....   | 16 |
| Figure 2.5. Recommended particle size distribution for rammed earth and compressed earth blocks.....  | 18 |
| Figure 2.6. Recommended soil plasticity range for rammed earth and compressed earth blocks.....   | 21 |
| Figure 2.7. Illustration as presented by Burroughs (2008) to determine the suitability of soils for rammed earth construction based on particle size gradation, plasticity and shrinkage properties .....                           | 23 |
| Figure 2.8 Relationship of wet compressive strength with (a) dry density and (b) placement moisture content (Reddy and Kumar, 2011a) .....  | 25 |
| Figure 2.9 Relationship between mechanical properties of earthen material with dry density and stabiliser content (Reddy and Kumar, 2011b).....   | 25 |
| Figure 2.10 Variation of stiffness and strength of earthen materials for different compacting pressures (Bruno et al., 2016).....   | 26 |
| Figure 2.11 Extrapolation for unstabilised rammed earth wall (Bui et al., 2009) .....   | 29 |
| Figure 2.12 Moisture buffering values of different earthen materials as per Rode et al., (2005) categorisation.....   | 32 |
| Figure 2.13 presents a typical life cycle of earthen construction material.....   | 33 |
| Figure 2.14 Different states of soil element.....   | 34 |
| Figure 2.15 A typical soil water retention curve as presented by Toll et al., (2015) .....  | 37 |
| Figure 2.16 Effect of clay mineralogy on soil water retention in the high suction regime (Likos, 2000).....   | 38 |
| Figure 2.17 Plot showing the variation of deviator stress and suction for different initial water contents, Reproduced from Jaquin et al., (2009). .....  | 39 |
| Figure 2.18 Variation of suction with water content (Bui et al., 2014) .....  | 40 |
| Figure 2.19 UCS of 5-1-4 and 7-1-2 mixes against humidity and temperature (Beckett and Augarde, 2012) .....   | 41 |
| Figure 2.20 Planar EMC failure envelope for California sandy loam used for rammed earth construction (Beckett et al., 2017) .....   | 42 |
| Figure 2.21 An example of how the monosaccharide units combine to form a biopolymer.....  | 45 |

|   |    |
|---|----|
| Figure 2.22 typical interaction of biopolymer with granular media as presented by Qureshi et al., (2014).....   | 45 |
| Figure 2.23. Typical chemical structure of guar gum.....  | 46 |
| Figure 2.24. Typical chemical structure of xanthan gum.....   | 47 |
| Figure 2.25. ESEM images of mine tailings treated with (a) xanthan gum (b) guar gum (Chen et al., 2013) .....   | 48 |
| Figure 2.26. Comparison of compressive strength for dry and wet mixing methods (Chang et al., 2015) .....   | 49 |
| Figure 2.27. SEM Images of xanthan gum treated soils (Chang et al., 2015) .....   | 50 |
| Figure 2.28. SEM Images of xanthan gum treated sand for different curing times (a) 1h, (b) 1 week and (c) 3 week (Ayeldeen et al., 2016) .....  | 50 |
| Figure 2.29. Particle size analysis tests (a) bentonite (b) kaolinite (Latifi et al., 2016) .....   | 52 |
| Chapter 3 Biopolymer Stabilisation .....  | 61 |
| Figure 3.1. Particle size distribution for the engineered soil mix.....   | 62 |
| Figure 3.2. Plasticity properties of the engineered soil mix.....   | 63 |
| Figure 3.3. Compaction characteristics of the engineered soil mix.....  | 64 |
| Figure 3.4. Effect of biopolymers on Atterberg limits of the soil. ....   | 66 |
| Figure 3.5. Effect of biopolymers on plasticity properties of the soil .....  | 67 |
| Figure 3.6. Effect of biopolymers on linear shrinkage of the soil.....  | 67 |
| Figure 3.7. Setup for preparation of UCS test specimens (a) Mould, (b) Static compactor.....  | 70 |
| Figure 3.8. Testing of UCS test specimens (a) universal testing machine, (b) dewpoint potentiometer.....  | 71 |
| Figure 3.9. Stress–strain behaviour in UC tests (for each %stabiliser only one test among three replicates is shown): (a) guar gum, 7 days, (b) guar gum, 28 days, (c) xanthan gum, 7 days, (d) xanthan gum, 28 days.....       | 72 |
| Figure. 3.10. UC test results for guar gum (average values of peak strength based on three replicates), (a) peak strength, (b) soil modulus .....   | 73 |
| Figure. 3.11. UC test results for xanthan gum (average values of peak strength based on three replicates), (a) peak strength, (b) soil modulus .....  | 73 |
| Figure 3.12. Direct tension tests a) NDTT illustration (b) Test-setup .....   | 74 |
| Figure 3.13. Stress–strain behaviour in Tensile tests (for each %stabiliser only one test among three replicates is shown): (a) guar gum, 7 days, (b) guar gum, 28 days, (c) xanthan gum, 7 days, (d) xanthan gum, 28 days..... | 76 |
| Figure 3.14. Failure patterns for 28-day tensile specimens for a) guar gum (b) xanthan gum .....  | 77 |
| Figure. 3.15. Tensile test results (average values of tensile strength based on three replicates), (a) guar gum, (b) xanthan gum .....  | 77 |

|  |     |
|--|-----|
| Figure. 3.16. Suction and water content values after UC tests (a) guar gum, (b) xanthan gum.....   | 78  |
| Figure 3.17. Effect of synergistic behaviour of biopolymers on plasticity properties of the soil.....  | 82  |
| Figure 3.18. Comparison of strength characteristics of synergistic combinations (a) UC peak strength and stiffness, (b) peak tensile strength.....     | 83  |
| Figure 3.19. Typical X-RCT machine setup.....  | 85  |
| Figure 3.20. Typical XRCT scan of soil.....  | 86  |
| Figure 3.21. XRCT Scan images for guar gum (a & b) and xanthan gum (c & d) stabilised specimens after 7 and 28 days respectively.....                  | 87  |
| Figure 3.22. Test setup for durability test as per NZS 4298 (1998).....  | 89  |
| Figure 3.23. Eroded surface after durability tests (a) guar gum and (b) xanthan gum.....   | 90  |
| Chapter 4 Geotechnical characterisation of biopolymer stabilised earthen construction material.....  | 95  |
| Figure 4.1 Illustration of the extended Mohr-Coulomb failure criterion.....  | 96  |
| Figure 4.2. Suction tests, (a) Specimen mould used to prepare suction specimens and (b) Moisture content tin containing suction cup and specimen.....  | 98  |
| Figure 4.3. Variation of total suction and change in gravimetric water content with drying time of unamended specimens.....                            | 100 |
| Figure 4.4. Variation of total suction and change in gravimetric water content with drying time of guar gum stabilised specimens.....                  | 101 |
| Figure 4.5. Variation of total suction and change in gravimetric water content with drying time of xanthan gum stabilised specimens.....               | 101 |
| Figure 4.6. Comparison of variation of total suction and change in gravimetric water content with time of all specimens.....                           | 102 |
| Figure 4.7. Soil water retention curve of unamended soil specimen.....   | 104 |
| Figure 4.8. Soil water retention curve of guar gum stabilised soil specimen.....   | 105 |
| Figure 4.9. Soil water retention curve of xanthan gum stabilised soil specimen.....  | 105 |
| Figure 4.10. Comparison of soil water retention curve for all combinations.....  | 106 |
| Figure 4.11. Total suction versus gravimetric water content of unamended soil in residual condition.....   | 107 |
| Figure 4.12. Total suction versus gravimetric water content of guar gum stabilised soil in residual condition.....                                     | 108 |
| Figure 4.13. Total suction versus gravimetric water content of xanthan gum stabilised soil in residual condition.....                                  | 108 |
| Figure 4.14. Typical setup for triaxial test.....  | 110 |
| Figure 4.15. Stress-strain plots of unamended soil specimens for curing periods, 1, 4, 7, 10, 14 and 28 days are plotted from a to f respectively..... | 112 |

|  |     |
|--|-----|
| Figure 4.16. Stress-strain plots of guar gum stabilised soil specimens for curing periods, 1, 4, 7, 10, 14 and 28 days are plotted from a to f respectively.....   | 113 |
| Figure 4.17. Stress-strain plots of xanthan gum stabilised soil specimens for curing periods, 1, 4, 7, 10,14 and 28 days are plotted from a to f respectively..... | 114 |
| Figure 4.18. p-q diagram of unamended soil specimens at different curing periods...  | 116 |
| Figure 4.19. p-q diagram of guar gum stabilised soil specimens at different curing periods.....  | 117 |
| Figure 4.20. p-q diagram of xanthan gum stabilised soil specimens at different curing periods.....   | 118 |
| Figure 4.21. Deviator stress/strain plots and typical failure pattern of guar gum stabilised soil specimens (a) 1 day, (b) 7 days, (c) 28 days .....               | 121 |
| Figure 4.22. Deviator stress/strain plots and typical failure pattern of xanthan gum stabilised soil specimens (a) 1 day, (b) 7 days, (c) 28 days .....            | 122 |
| Figure 4.23. p-q diagram of guar gum stabilised soil specimens at different curing periods.....  | 123 |
| Figure 4.24. p-q diagram of xanthan gum stabilised soil specimens at different curing periods.....   | 124 |
| Figure 4.25. Flow chart of different steps involved in image processing and analyses using Avizo.....  | 126 |
| Figure 4.26. X-RCT scans of unamended soil specimens at 1 – day curing period, (a) soil (b) porosity and (c) soil with porosity.....                               | 128 |
| Figure 4.27. X-RCT scans of unamended soil specimens at 7 – day curing period, (a) soil (b) porosity and (c) soil with porosity.....                               | 128 |
| Figure 4.28. X-RCT scans of unamended soil specimens at 28 – day curing period, (a) soil (b) porosity and (c) soil with porosity.....                              | 128 |
| Figure 4.29. X-RCT scans of guar gum stabilised soil specimens at 1 – day curing period, (a) soil (b) porosity and (c) soil with porosity.....                     | 129 |
| Figure 4.30. X-RCT scans of guar gum stabilised soil specimens at 7 – day curing period, (a) soil (b) porosity and (c) soil with porosity.....                     | 129 |
| Figure 4.31. X-RCT scans of guar gum stabilised soil specimens at 28 – day curing period, (a) soil (b) porosity and (c) soil with porosity.....                    | 129 |
| Figure 4.34. X-RCT scans of xanthan gum stabilised soil specimens at 28 – day curing period, (a) soil (b) porosity and (c) soil with porosity.....                 | 130 |
| Figure 4.35. Void size distribution of all the specimens after 1 day of curing.....  | 132 |
| Figure 4.36. Void size distribution of all specimens after 7 days of curing.....   | 133 |
| Figure 4.37. Void size distribution of all specimens after 28 days of curing.....  | 134 |
| Chapter 5 Assessment of biopolymer stabilised earthen construction material as a building material.....  | 139 |
| Figure. 5.1. Comparison of particle size gradation of sands used .....   | 140 |

|   |     |
|---|-----|
| Figure. 5.2. Preparation of tile specimens, (a) Denison T60C hydraulic press and (b) 150 mm cube mould .....  | 141 |
| Figure. 5.3. Manufacturing of large cylinders, (a) Zwick Roell press and (b) Mould for cylinders .....  | 142 |
| Figure. 5.4. Manufacturing of bricks, (a) 3R RP 3000 TC/TH press, (b) dismantled open compaction mould, and (c) assembled compaction mould.....                         | 143 |
| Figure. 5.5. Steps for manufacturing bricks .....   | 144 |
| Figure. 5.6. Test setup for Geelong erosion test .....  | 147 |
| Figure. 5.7. Average depth of erosion for (a) tile specimens and (b) cylindrical specimens .....  | 148 |
| Figure. 5.8. Rate of erosion for (a) guar gum, 7 days, (b) guar gum, 28 days, (c) xanthan gum, 7 days, (d) xanthan gum, 28 days.....                                    | 149 |
| Figure. 5.9. Test Setup for Contact test.....   | 150 |
| Figure. 5.10. Conditions of bricks before and after contact tests for, (a) unamended bricks, (b) guar gum stabilised bricks, and (c) xanthan gum stabilised bricks..... | 151 |
| Figure. 5.11. Test setup for the suction test .....   | 152 |
| Figure. 5.12. Condition of bricks before and after the suction tests .....  | 153 |
| Figure. 5.13. Test setup for dip tests.....   | 154 |
| Figure. 5.14. Loss of mass for all the bricks after dip tests .....   | 155 |
| Figure. 5.15. Conditions of bricks after dip tests: (a) unamended brick, (b) guar gum stabilised brick and (c) xanthan gum stabilised brick.....                        | 155 |
| Figure. 5.16. Moisture buffering tests, (a) Climatic chamber and (b) Cylindrical samples and (c) Brick samples.....   | 159 |
| Figure. 5.17. Moisture absorption versus time for all cylindrical samples.....  | 160 |
| Figure. 5.18. Moisture absorption versus time for all biopolymer stabilised samples.....  | 161 |
| Figure. 5.19. Comparison of moisture absorption for the last stable cycle, (a) guar gum and (b) xanthan gum.....  | 162 |
| Figure. 5.20. Moisture buffering value (uptake versus release) – guar gum samples.....  | 163 |
| Figure. 5.21. Moisture buffering value (uptake versus release) – xanthan gum samples .....  | 163 |
| Figure. 5.22. Moisture buffering value ( $MBV_{\text{practical}}$ ) for all samples.....  | 164 |
| Figure. 5.23. Comparison of moisture buffering values of present study with literature data .....   | 165 |
| Figure. 5.24. Comparison of particle size distribution of engineered soil mix with recycled soil mixes .....  | 168 |
| Figure 5.25. Plasticity properties of the unamended, stabilised and recycled material .....   | 169 |
| Figure 5.26. Variation of Linear Shrinkage .....  | 170 |

|   |     |
|---|-----|
| Chapter 6 Conclusions .....   | 176 |
| Figure 6.1 Field implementation, (a) constructed rammed earth wallets, (b) cracks<br>and (c) water retention in rammed earth wallet ..... | 184 |

# Acknowledgements

When I received the offer to work as a Marie Curie Early Stage Researcher, I was overwhelmed with joy and excitement to start my career as a researcher. From the day I joined Durham University to this day in the University of Pau and Pays de L'Adour, where I am submitting my research thesis, I see myself to have grown to be a confident researcher. This is entirely due to the support which I have received from my supervisors. I humbly thank Dr Paul Hughes, Professor Charles Augarde, Dr Celine Perlot and Professor Domenico Gallipoli for their support, guidance and inspiration.

I acknowledge the support of the European Commission through the Marie Skłodowska-Curie Innovative Training Networks (ITN-ETN) project TERRE 'Training Engineers and Researchers to Rethink geotechnical Engineering for a low carbon future' for providing this fellowship. Being part of TERRE was inspirational as I was able to meet fellow Early Stage Researchers and other reputed research fraternity in geotechnical engineering. I thank the entire network led by Professor Alessandro Tarantino for organising various doctoral schools and workshops at different research institutes. These research programmes helped me to improve my research skills and gain knowledge of unsaturated soil mechanics. I thank Dr. Agostino Walter Bruno for his timely and helpful guidance during the project.

Working in two universities, I had to get adjusted to two different work cultures and administrative procedures. Relocating to different country posed many challenges in terms of visa applications and accommodation. Further, as an experimental research programme, there were many issues faced in the laboratory. I was able to solve all these challenges with the support of administrative staff, laboratory staff and fellow colleagues. Though I cannot name each one of them here, I thank one and all who have supported me whenever I needed a helping hand.

I thank my family members who have been a constant support to me. I thank Professor H B Nagaraj from BMS College of Engineering for constant encouragement. Lastly and more importantly, I thank my ever-supporting wife, Mamatha and sweet little son Nikunj who have given me their unwavering support in completing my research thesis.

Regards,

Sravan

# Publications

The research findings presented in this thesis have been published, presented or submitted. The list of research publications from the thesis is as follows

- Muguda S, Booth SJ, Hughes PN, Augarde CE, Perlot C, Bruno AW, and Gallipoli D. 2017. Mechanical properties of biopolymer-stabilised soil-based construction materials. *Géotechnique Letters*, 7(4), 309–314.
- Muguda S, Booth SJ, Hughes PN, Augarde CE, Perlot C, Bruno AW, and Gallipoli D. 2018. Preliminary study on use of biopolymers in earthen construction. In *The 7th International conference on Unsaturated soils*. Hong Kong.
- Muguda S, Lucas G, Hughes PN, Augarde CE, Cuccurullo A, Perlot C, Bruno AW and Gallipoli D. 2018. Advances in using biological stabilisers and hyper-compaction for sustainable earthen construction materials. In *International Symposium on Earthen Structures 2018*. Bengaluru.
- Muguda S, Hughes PN, Augarde CE, Perlot C, Bruno AW, and Gallipoli D. 2019. Geotechnical characterisation of recycled biopolymer-stabilised earthen materials. In *Proceedings of the XVII ECSMGE-2019*. Reykjavik, Iceland.
- Muguda S, Hughes PN, Augarde CE, Perlot C, Bruno AW, and Gallipoli D. Geotechnical characteristics of biopolymer-stabilised earthen materials. Submitted to *Géotechnique*.
- Muguda S, Hughes PN, Augarde CE, Perlot C, Bruno AW, and Gallipoli D. Durability, Hygroscopic and Recycability properties of biopolymer-stabilised earthen construction materials. Submitted to *Construction and Building Materials*.

# Nomenclature

## Abbreviations

|      |  |                 |   |
|------|--|-----------------|---|
| CEB  | Compressed earth block                     | $s$             | Soil suction                                  |
| CSB  | Cement stabilised block                    | $u_a$           | Pore air pressure                             |
| CSEB | Compressed stabilised earth block          | $u_w$           | Pore water pressure                           |
| COV  | Co-efficient of variation                  | $\Psi$          | Total Suction                                 |
| LS   | Linear Shrinkage                           | $\Psi_m$        | Matric suction of soil                        |
| PI   | Plasticity Index                           | $\Psi_o$        | Osmotic suction of soil                       |
| MDD  | Maximum Dry Density                        | $\Psi_r$        | Residual soil suction                         |
| OWC  | Optimum Water content                      | $C$             | Capillary component of matric suction of soil |
| MBV  | Moisture buffering value                   | $\kappa$        | Water-air curvature                           |
| ESEM | Environmental scanning electron microscopy | $A$             | Adsorptive component of suction               |
| SEM  | Scanning electron microscopy               | $t$             | Film thickness                                |
| UC   | Unconfined Compression                     | $\gamma_{dmax}$ | Maximum dry density                           |
| NDTT | Newcastle Direct Tensile test              | $w_L$           | Liquid Limit                                  |
| SWCC | Soil water characteristic curve            | $w_p$           | Plastic Limit                                 |
| SWRC | Soil water retention curve                 | $\rho_w$        | Density of water                              |
| CT   | Computed Tomography                        | $R$             | Universal gas constant                        |
| XRCT | X-Ray Computed Tomography                  | $T$             | Absolute temperature                          |
| ORP  | Oxidation reduction potential              | RH              | Relative Humidity                             |
| DO   | Dissolved oxygen                           | $w_v$           | Molecular mass of water vapour                |
| WHO  | World Health Organisation                  | $w$             | Gravimetric water content                     |
|      |  | $w_{sat}$       | Saturated gravimetric water content           |
|      |  | $C(s)$          | Correction function                           |
|      |  | $a, m \& n$     | Fitting parameters                            |
|      |  | $q$             | Deviator stress                               |
|      |  | $p$             | Mean stress                                   |
|      |  | $C$             | Intercept of failure envelope                 |
|      |  | $M$             | Slope of failure envelope                     |

## Symbols

|           |   |
|-----------|---|
| $e$       | Void ratio  |
| $V_v$     | Volume of voids   |
| $V_s$     | Volume of solids  |
| $n$       | Porosity  |
| $V$       | Total Volume of soil  |
| $S_r$     | Degree of Saturation  |
| $\tau$    | Total shear strength of soil  |
| $\tau'$   | Effective shear strength of soil  |
| $c$       | Cohesion of soil  |
| $c'$      | Effective cohesion of soil  |
| $\sigma$  | Total normal stress of soil   |
| $\sigma'$ | Effective normal stress of soil   |
| $\phi$    | Angle of internal friction under total stress condition                                 |
| $\phi'$   | Angle of internal friction under total stress condition                                 |
| $\phi_b$  | Angle indicating the rate of increase in shear strength relative to the matric suction. |

# Chapter 1

## Introduction

### 1.1 “Earth” as a building material

Earth as a building material is an idea inspired by nature. Living organisms such as termites and ovenbirds extensively use earth to build their homes, which provide them suitable habitation against harsh environmental forces (Gould and Gould, 2012). Humans have been using earth as a building material for over 10,000 years. From the earliest known use as *sundried adobe blocks* in Jericho, Palestine (9000 BC), remains of *rammed earth foundations* in Assyria (5000 BC), portions of Great Wall of China and other earthen structures suggest that earth was used historically in various forms suited to the social, economic, geological and climatic conditions (Jaquin and Augarde, 2012; Schroeder, 2016; Vyncke et al., 2018). Earthen materials can be divided into three categories, namely, *adobe or compressed earth blocks*, *cob*, and *rammed earth* (Houben and Guillaud, 1994; Keefe, 2005; Pacheco-Torgal and Jalali, 2012).

Adobe and compressed earth blocks are unit-based materials, while cob and rammed earth are in-situ based earthen construction techniques. *Adobe blocks* are hand moulded sundried bricks where a wet soil mixture is made into a brick using a wooden mould. In *compressed earth blocks*, a moist earth mixture is placed in a brick mould and compacted to a specific pressure using a mechanical or hydraulic press. *Cob* is a wet mixture of soil and straw, set in layers to form a structure in-situ. Similar to adobe, the final cob structure is left to dry. *Rammed earth* walls are layers of moist earth compacted within formwork. On reaching the final wall height, the formwork is removed, and the solid wall is left to dry. In simple terms, earthen materials can be defined as a compacted mixture of soil and water placed as a building unit. On drying, these earthen materials gain strength providing stability to the earthen structure. However, in this form, these materials are susceptible to deterioration against wind and rainfall. To improve durability, traditionally, these materials have been stabilised through the inclusion of straw or organic compounds such as plant extracts and animal dung (Ngowi, 1997; Plank, 2004). The stabilisations have improved the durability of these materials and ensured the longevity of earthen structures. Though these vernacular building techniques utilising earth have existed in the past, its relevance in the present-day construction has dwindled due to the advent of modern building materials such as timber, steel and concrete.

### 1.2 Revival of earthen construction

There was an enlivened interest for earthen materials in the early part of the twentieth century where these materials were studied under the framework of pavement geotechnics (Olivier and Mesbah, 1987). However, since 1970, the interest in earthen materials has primarily arisen to develop an alternative low-cost walling material and to fulfil housing needs in developing

countries. Another source of interest for earthen materials was in maintenance and restoration of historic earthen structures (Germen, 1979). Initial attempts to promote earth as a building material was taken up in 1950 via the United Nations; subsequently, earthen building was promoted during the 1976 Vancouver Assembly of the United Nations Conference on Human Settlements (UN Bulletin No. 4, 1950; UNHCS, 1976; UNIDO, 1980; Kerali, 2001). During these promotions, it was noted that earthen materials were perceived to be primitive and inferior to cement-based materials concerning its durability (Etzion and Saller, 1987). Subsequently, to eradicate this perception scientifically, much research work has focussed on different aspects of earthen materials. Soil characterisation, suitability of stabilisers and improvement in production and construction techniques are a few of the initial research areas investigated.

Sub soil, which is the main ingredient of earthen construction materials, is necessarily a mixture of different components namely gravel, sand, silt and clay. The clay ensures bonding, sand and gravel act as a skeleton and silt fills up the voids making the material denser (Etzion and Saller, 1987). Unlike sand and silt which are inert, clay is sensitive to water, hence prior understanding of the clay behaviour in soil is essential. Clays are usually made of three types of minerals, namely, kaolin, illite and montmorillonite. Usually, soils having kaolinite as the primary clay mineral are preferred for earthen construction as they are less susceptible to volume change. Desired proportions of sand, silt and clay vary depending on the earthen construction technique adopted (Etzion and Saller, 1987). Hence, several researchers across the world have studied the suitability of various soils based on soil gradation, plasticity and shrinkage properties for different earthen construction techniques and have reported acceptable limits of these parameters. Though there are reported variations in the recommended limits, in general, for adobe, higher clay contents at about 30-50%, 0-20% silt and 50-70% sand is acceptable. In the case of rammed earth and compressed earth blocks, lower clay contents at about 0-20%, 0-50% silt and 50-80% sand are recommended (Cytryn, 1957; Olivier and Mesbah, 1987; Houben and Guillaud, 1994; Hall and Djerbib, 2004; Reddy et al., 2007; Burroughs, 2008). In terms of soil plasticity, soils having a liquid limit in the range of 30-50% and plasticity index less than 20% are preferred for earthen materials (Fitzmaurice, 1958; Bryan, 1988). Recently, characterisation in terms of shrinkage properties suggests that soils having linear shrinkage less than 5.0% are preferable for earthen materials (Burroughs, 2010). Soils which fall within these categories are deemed to be suitable for earthen construction.

To be competitive in modern construction, the mechanical and durability properties of earthen materials need enhancement. In order to achieve this, “*soil stabilisation*”, a technique effectively employed in pavement geotechnics has been considered in earthen construction. Whilst different stabilisers such as cement, lime, bitumen and polymers have been explored, it is “*cement*” which tends to be the most popular amongst these stabilisers. Hence, extensive research studies have been undertaken to understand the role of cement as a stabiliser for earthen construction materials. A number of references indicate that to compete with conventional fired bricks, the wet compressive strength of cement stabilised earthen blocks

should be in the range of 1.5-3.5 MPa (Fitzmaurice, 1958; Houben and Guillaud, 1994; Webb, 1994; IS 1725, 2013). Earthen blocks when stabilised with cement at 7-12% of soil mass achieve this desired strength and in turn durability (Fitzmaurice, 1958; Spence, 1975; Bryan, 1988; Reddy and Jagadish, 1989; Houben and Guillaud, 1994; Walker and Stace, 1997; Ciancio and Boulter, 2012). For rammed earth walls, the recommended characteristic compressive strength should be higher than 2MPa; this corresponds to the minimum strength required for one-storey external walls of 300mm thickness (Middleton and Schneider, 1987; Walker, 2002). The addition of 5-10% cement by soil mass is sufficient to produce this desired strength and durability in rammed earth walls (Webb, 1994; Reddy and Kumar, 2009). Soil stabilisation has been an important innovation which has not only improved the strength and durability of earthen materials but has also helped to eradicate the perception of earthen materials being an inferior building material.

Soil mixtures used in adobe and cob essentially have higher clay contents and are mixed at higher water contents. In order to have improved mechanical performance, it is necessary that the clay in the soil mixture is uniformly distributed (Hamard et al., 2016). Hence, soil mixtures are usually pre-soaked and mixed thoroughly. Traditionally, mixing for adobe and cob was done manually; however, modern innovations have developed mechanised mixing which has improved mixing action and reduced labour (Hamard et al., 2016). Attempts to improve soil mixing have been made through the use of concrete mixers, mortar mixers and rotavators (Keefe, 2005). On the other hand, compressed earth blocks and rammed earth are mixed at lower water contents and compacted to a specific pressure. Hence, compaction plays a vital role in these materials. As an initial step towards improvement in earth blocks, CINVA-Ram, an earth block making machine, was developed in 1956 (Webb, 1983). Subsequently, many block making machines such as ASTRAM, CETA-Ram, CTA Triple-Block Press have been developed in different countries (Webb, 1983; Mukerji, 1986). Production of compressed earth blocks through block making machines has ensured control over their material properties and dimensional accuracies. Rammed earth walls have undergone two significant innovations. Pneumatic backfill tampers powered with air compressors have replaced traditional wooden rammers which has ensured better ramming (Easton and Easton, 2012) and the traditional wooden formwork has been replaced with different varieties of modern formwork which enables the construction of continuous rammed earth walls with precise geometries. Both of these developments have modernised rammed earth construction and made it a construction material which is highly durable and aesthetically pleasing.

Extensive laboratory research and field implementations carried over four decades on the above topics have led to the development of technical standards for different earthen materials in a few countries around the world. These standards ensure quality control over material characterisation, structural design, construction techniques and material testing. Not only has the revival of earthen construction ensured the development of competitive building materials but it has also increased understanding of functionality, energy costs and sustainability of these construction products. With these developments, modern earth

construction has redefined the past notion of being inferior, primitive structures to architecturally pleasing durable structures. However, even with these developments, the general uptake of earthen construction materials in construction industry is still low.

### 1.3 Earthen materials – Modern perspective

With the revival of earthen construction, the modern perspective of earthen material is that it is a building material which has inherent sustainable characteristics. Characteristics such as low embodied energy, low operational energy, fire resistant and recycling capabilities have made earthen materials an attractive sustainable building material in modern construction.

- **Embodied energy.** Earthen materials have less embodied energy compared to fired bricks or concrete. They require a mere 1% of the required energy to manufacture and process an equivalent quantity of cement concrete (Deboucha and Hashim, 2011). Another example is the cumulative energy demand of compressed stabilised earth blocks at nearly half of traditional fired bricks (Schroeder, 2016).
- **Energy efficiency.** With proper design, earth buildings over their lifetime consume less operational energy when compared to conventional structures. Due to the synergy of thermal conductivity and hygroscopic properties of earthen materials, the indoor environment of earth buildings tends to be comfortable during both summer and winter (Gallipoli et al., 2014). As earthen materials can acclimatise themselves to any natural environment, they help to reduce operational costs of heating or cooling in an earth building.
- **Carbon emissions.** Unlike concrete and steel buildings, earth structures have the least carbon emissions associated with them (Pacheco-Torgal and Jalali, 2012). As a natural product, earthen materials undergo less processing for construction which ensures less carbon is emitted (Keefe, 2005). With a small carbon footprint, earth buildings can reduce the annual carbon emissions contributed by building construction.
- **Recycling.** On demolition, earthen materials are recycled easily. As these materials would have undergone the least modification during construction, they need less energy to recycle them (Schroeder, 2016). The recycled material can be reused or safely disposed of with the least environmental impact. The potential to recycle these materials prevents the generation of demolition waste which is one of the most significant contributors of waste worldwide.
- **Acoustic insulation.** Earth buildings have excellent acoustic insulating properties (Calkins, 2008). Gallipoli et al., (2014) have reported that a 0.3m thick rammed earth wall prepared at a dry density of 2100 kg/m<sup>3</sup> has a relatively high sound reduction index of 58.3 dB; this should be compared to UK building regulations which recommend a sound reduction index value should be a minimum of 40dB.

- **Fire Resistance.** Earth materials are naturally fire resistant and harden on exposure to fire. Many chimneys and fireplaces which have been constructed using earthen materials have not undergone any damage due to fire (Ciurileanu and Horvath, 2012).

With these inherent characteristics, earthen materials are often considered “*green*” and “*sustainable*” building materials. However, earthen materials do have few drawbacks which limit their adoption into mainstream construction.

- **Soil suitability.** For all kinds of earthen construction techniques, only soils having the desired proportion of sand, silt and clay are considered suitable for construction. This may limit the possibility of using any soil available in a given locality. If locally available soil is deemed unfit, suitable soil must be sourced from different localities. Sourcing of suitable soil involves transportation which would increase the carbon footprint and energy consumption associated with the material.
- **Construction standards.** Unlike concrete structures, design and construction using earthen construction materials depend upon standards which have often been empirically derived rather than obtained from engineering science. The empirical design approach has not always brought out the potential benefits of earthen materials which if accurately quantified can bring down the construction costs (Gallipoli et al., 2017).
- **Workmanship.** For earth buildings, two levels of quality control are necessary, one during selection, processing and storage of the soil, and another during construction to ensure that each unit of earthen materials achieves the required density. These checks ensure that the earth building meets the required design strength and durability. Hence, the built quality of earth buildings highly relies on the workmanship carried out at the site (Crowley, 1997).
- **Durability.** The main drawback of any earthen material is its inability to withstand deterioration against surface erosion. Research studies have shown that unstabilised earthen materials are highly susceptible to damage in wet climates and persistent rainfall leads to deterioration of the structure (Bui et al., 2009). For instance, extrapolated results indicate 25 to 80mm erosion over a period of 100 years which is unacceptable in modern construction.
- **Dependence on chemical stabilisers.** In order to improve durability, earthen materials are often treated with chemical stabilisers such as cement and lime. Though the treatment leads to improved engineering properties, the dependence on chemical stabilisers represents a compromise on cost and reduces the green credentials of these materials (Gallipoli et al., 2017).
- **Seismic vulnerability.** Earth buildings have a high seismic vulnerability because they are dense and possess low tensile strength. Hence, earth materials usually exhibit brittle failure which is usually avoided in structural design. Hence, earth buildings are usually limited to geographical locations which are which is less prone to seismic activity.

- **Poor insulation.** At extreme climatic conditions, earth buildings pose problems with regards to insulation. The earthen walls require proper insulation in order to make the earthen building habitable(Krayenhoff, 2012).

### 1.3.1 Problems with modern earthen construction

Of all the drawbacks mentioned above, the dependency of earthen materials on chemical stabilisers has a direct impact on the inherent characteristics which make them sustainable. The inclusion of chemical stabilisers, whilst improving durability, has to an extent reduced the “green” credentials of earthen materials. Research has shown that the inclusion of chemical stabilisers to earthen materials has led to increased embodied energy and carbon footprint, increased operational energy and reduced recyclability potential (Gallipoli et al., 2017).

Cement production, which contributes 7-8% to global carbon emissions annually, is the most popular stabiliser in earthen construction. Studies have shown that the addition of cement affects embodied energy and carbon footprint of earthen materials. Reddy and Kumar (2010) report that in cement stabilised rammed earth walls, embodied energy of cement significantly contributes to the overall embodied energy of the earthen material. Typically, earthen materials stabilised with cement at 9% have an equivalent carbon footprint to that of a fired brick or weak concrete (Lax, 2010). Maskell et al.,(2014) studied the environmental impact of different chemical stabilisers used in earthen construction. It was reported that in practice, the optimum dosage of the stabiliser is determined on the basis of achieving maximum strength and durability, but it is seldom determined in terms of sustainability. As an example, the acceptable cement content to have a sustainable 100mm thick rammed earth wall was estimated to be 6.9%, however, in practice, the walls are much thicker and recommended cement contents are much higher. These studies reveal that the dependence on cement for strength and durability has led to increased embodied energy and carbon footprint which are above the threshold values of sustainability.

Hygroscopic behaviour of earthen materials controls the indoor environment of the building and has a direct impact on air-conditioning. McGregor et al., (2014) undertook a comparative study on the hygroscopic behaviour of unstabilised and stabilised compressed earth blocks. Different chemical stabilisers, namely cement, lime and sodium hydroxide were used in this study. It was noted that the unstabilised blocks had slightly higher moisture buffering value (MBV) than the stabilised blocks, indicating better hygroscopic behaviour. Within the stabilised versions, cement had better performance than lime and sodium hydroxide stabilised blocks. Recently, Arrigoni et al.,(2017) undertook a study to understand the impact of stabilisation on the hygroscopic behaviour of rammed earth. Cement and calcium carbide residue were used as stabilisers in this study. It was reported that stabilisation had a drastic reduction in the hygroscopic behaviour of the stabilised rammed earth. Research findings from these studies indicate that unstabilised earthen materials have better hygroscopic behaviour than stabilised alternatives. The construction technique and the stabiliser used further influences the

---

hygroscopic performance of the earthen materials. As hygroscopic behaviour has a direct impact on the operational energy of the building, it is necessary that the stabilised versions match the performances of unstabilised earthen materials.

Stabilised earthen structures which commonly rely on chemical stabilisers for durability pose a severe obstacle in recycling the material on demolition. On stabilisation, the soil particles are firmly bonded through strong cementitious bonds which are hard to disintegrate. Unlike unstabilised earthen materials which can be recycled and reused easily, the demolished stabilised versions are usually downcycled or dumped in landfill (Schroeder, 2016). The inability to recycle the modern earthen material leads to the production of construction demolition waste which is one of the most significant contributors to the total waste globally. Hence, modern earthen construction needs to employ alternative stabilisers which ensure the stabilised material is both durable and recyclable on demolition.

### 1.4 Research aims and objectives

In a pursuit to compete with modern building materials, earthen construction materials have compromised their inherent green credentials. In modern construction, earthen construction materials were initially preferred for their green credentials, and now these materials are scrutinised for their dependence on stabilisers with high carbon costs. With the growing global interest in sustainability, future construction is expected to utilise sustainable materials. In this regard, earthen materials have the potential be the most appropriate building materials provided they re-establish their inherent green credentials. Bio-stabilisation is an exciting stabilisation technique which is being investigated actively in geotechnical engineering applications. In particular, microbial induced calcium precipitation and biopolymers have been viewed as possible alternatives for conventional stabilisers especially in soil treatment and improvement (Ivanov and Stabnikov, 2016; Pacheco-Torgal et al., 2016). This situation motivates this study to find a suitable bio-stabiliser as an alternative to high energy consuming stabilisers which may provide desirable strength and durability to earthen materials.

The main aim of this thesis is to identify a suitable bio-stabiliser, understand its potential as a stabiliser through geotechnical characterisation and assess the performance of bio-stabilised earthen material as a building material. In order to achieve this the following objectives for the research programme are considered.

- **Bio-stabilisation.** To identify and optimise the identified bio-stabilisation technique for earthen construction materials
- **Geotechnical characterisation.** To establish mechanical and hydraulic behaviour of the bio-stabilised earthen material through soil mechanics principles.
- **Building material assessment.** To evaluate the durability, hygroscopic behaviour and recycling potential of bio-stabilised earthen materials.

### 1.5 Thesis structure

In Chapter 2 of the thesis, three important aspects which are interlinked in this work namely, earthen construction, unsaturated soil mechanics and bio-stabilisation are discussed. Detailed discussions on the earthen construction techniques for which bio-stabilisation is employed in this study are presented herein. Further, a brief introduction to unsaturated soil mechanics is presented which contributes to an understanding of the mechanical and hydraulic behaviours of earthen materials. As the thesis aims in utilising a bio-stabilisation technique in earthen construction, discussions on different bio-stabilisation techniques, advantages and disadvantages of these techniques and the literature relating to the shortlisted bio-stabilisers are presented. In this study, biopolymers namely *guar* and *xanthan* gum are chosen as potential stabilisers.

Chapter 3 presents the test results of a preliminary experimental campaign undertaken to understand biopolymer soil stabilisation. Results of air-dried compressive and tensile strengths for earthen material stabilised with different biopolymer dosages are presented. The test results yielded an understanding of how both strengths are influenced by biopolymer interactions and soil suction. On comparing the strengths with those of unamended and cement stabilised earthen material an optimum stabiliser content is determined. Further, results of preliminary durability tests and X-ray computed tomography scans are presented. Understanding of biopolymer stabilisation is crucial for subsequent campaigns of geotechnical characterisation and building material assessment.

Chapter 4 investigates the *mechanical* and *hydraulic* behaviour of biopolymer stabilised earthen construction materials. To evaluate the mechanical behaviour, constant water content triaxial tests are done on air-dried biopolymer stabilised earthen material. Soil-water retention properties are determined to understand the hydraulic behaviour of the biopolymer stabilised material. The effect of biopolymer stabilisation on macropore structure at different curing periods are presented through x-ray computed tomography scans.

Assessment of biopolymer stabilised materials as a building material are presented in Chapter 5. *Durability* performance of biopolymer stabilised earthen construction materials is evaluated through different tests namely erosional resistance, immersion, contact and suction tests, and the results of these tests are presented in this chapter. Tests results of the *hygroscopic behaviour* (via moisture buffering tests) and *recyclability potential* (through standard geotechnical tests) of these materials are also presented. Further, the performance of biopolymer stabilised material is compared with unamended and cement stabilised earthen materials in this chapter.

Conclusions of the research findings from Chapters 3 to 5, as well as potential implications of biopolymer soil stabilisation and future recommendations, are presented in Chapter 6.

### References

- Arrigoni A, Grillet AC, Pelosato R, Dotelli G, Beckett C, Woloszyn M, and Ciancio D. 2017. Reduction of rammed earth's hygroscopic performance under stabilisation: an experimental investigation. *Building and Environment*, 115, 358–367.
- Bryan AJ. 1988. Criteria for the suitability of soil for cement stabilization. *Building and Environment*, 23(4), 309–319.
- Bui QB, Morel JC, Venkatarama Reddy B, and Ghayad W. 2009. Durability of rammed earth walls exposed for 20 years to natural weathering. *Building and Environment*, 44(5), 912–919.
- Burroughs S. 2008. Soil Property Criteria for Rammed Earth Stabilization. *Journal of Materials in Civil Engineering*, 20(3), 264–273.
- Burroughs S. 2010. Recommendations for the Selection, Stabilization, and Compaction of Soil for Rammed Earth Wall Construction. *Journal of Green Building*, 5(1), 101–114.
- Calkins M. 2008. *Materials for Sustainable Sites: A Complete Guide to the Evaluation, Selection, and Use of Sustainable Construction Materials*. John Wiley & Sons.
- Ciancio D, and Boulter M. 2012. Stabilised rammed earth: a case study in Western Australia. *Proceedings of the Institution of Civil Engineers - Engineering Sustainability*, 165(2), 141–154.
- Ciurileanu GT, and Horvath IB. 2012. Modular Building Using Rammed Earth. *Acta Technica Napocensis: Civil Engineering & Architecture*, 55(2), 173–181.
- Crowley M. 1997. Quality control for earth structures. *Australian Institute of Building Papers*, 8, 109–118.
- Cytryn S. 1957. *Soil Construction: Its Principles and Application for Housing*. Jerusalem: The Weizman Science Press of Israel.
- Deboucha S, and Hashim R. 2011. A review on bricks and stabilized compressed earth blocks, 6(3), 499–506.
- Easton D, and Easton T. 2012. Modern rammed earth construction techniques. In M. R. Hall, R. Lindsay, & M. B. T.-M. E. B. Krayenhoff (Eds.), *Modern Earth Buildings* (pp. 364–384). Elsevier.
- Etzion Y, and Saller M. 1987. Earth Construction—A Review of Needs and Methods. *Architectural Science Review*, 30(2), 43–48.
- Fitzmaurice R. 1958. *Manual on stabilized soil construction for housing*. New York: United Nations, Technical Assistance Programme.
- Gallipoli D, Bruno AW, Perlot C, and Mendes J. 2017. A geotechnical perspective of raw earth building. *Acta Geotechnica*, 12(3), 463–478.
- Gallipoli D, Bruno AW, Perlot C, and Salmon N. 2014. *Raw earth construction: is there a role for unsaturated soil mechanics*. Taylor & Francis Group, London, UK.
- Germen A. 1979. The endurance of earths as building material and the discreet but continuous charm of adobe. *METU Journal of the Faculty of Architecture*, 5(1), 37–68.
- Gould JL, and Gould CG. 2012. *Animal architects: building and the evolution of intelligence*. Basic Books.
- Hall M, and Djerbib Y. 2004. Rammed earth sample production: context, recommendations and consistency. *Construction and Building Materials*, 18(4), 281–286.
- Hamard E, Cazacliu B, Razakamanantsoa A, and Morel JC. 2016. Cob, a vernacular earth construction process in the context of modern sustainable building. *Building and Environment*, 106, 103–119.
- Houben H, and Guillaud H. 1994. *Earth construction: a comprehensive guide*. Intermediate Technology Publications.
- IS 1725. 2013. *Indian Standard IS 1725: Stabilized soil blocks used in general building construction — Specification*. New Delhi: Bureau of Indian Standards.
- Ivanov V, and Stabnikov V. 2016. *Construction Biotechnology: Biogeochemistry, Microbiology and Biotechnology of Construction Materials and Processes*. Springer.
- Jaquin PA, and Augarde C. 2012. *Earth building: history, science and conservation*. Bracknell: IHS BRE Press.
- Keefe L. 2005. *Earth Building Methods and Materials, repair and conservation*. Taylor & Francis.
- Kerali AG. 2001. *Durability of Compressed and Cement Stabilised Building Blocks*. University of Warwick.
- Krayenhoff M. 2012. North American modern earth construction. In *Modern Earth Buildings* (pp. 561–608). Elsevier.
- Lax C. 2010. *Life cycle assessment of rammed earth*. University of Bath. Retrieved from [http://www.ebuk.uk.com/docs/Dissertation\\_Clar\\_e\\_Lax.pdf](http://www.ebuk.uk.com/docs/Dissertation_Clar_e_Lax.pdf)
- Maskell D, Heath A, and Walker P. 2014. Comparing the Environmental Impact of Stabilisers for Unfired Earth Construction. *Key Engineering Materials*, 600, 132–143.
- McGregor F, Heath A, Fodde E, and Shea A. 2014.

## Chapter 1. Introduction

---

- Conditions affecting the moisture buffering measurement performed on compressed earth blocks. *Building and Environment*, 75, 11–18.
- Middleton GF, and Schneider LM. 1987. *Bulletin 5: Earth-Wall Construction (Vol. 5)*. Sydney, Australia: CSIRO.
- Mukerji K. 1986. Soil block presses. Publication of Deutsches Zentrum für Entwicklungstechnologien – GATE, a Division of the Deutsche Gesellschaft für Technische Zusammenarbeit (GTZ) GmbH.
- Ngowi AB. 1997. Improving the traditional earth construction: a case study of Botswana. *Construction and Building Materials*, 11(1), 1–7.
- Olivier M, and Mesbah A. 1987. Influence of different parameters on the resistance of earth, used as a building material. In *International Conference on Mud Architecture*, Trivandrum, India (Vol. 25).
- Pacheco-Torgal F, Ivanov V, Karak N, and Jonkers H. 2016. *Biopolymers and Biotech Admixtures for Eco-Efficient Construction Materials*. Woodhead Publishing.
- Pacheco-Torgal F, and Jalali S. 2012. Earth construction: Lessons from the past for future eco-efficient construction. *Construction and Building Materials*, 29, 512–519.
- Plank J. 2004. Applications of biopolymers and other biotechnological products in building materials. *Applied Microbiology and Biotechnology*, 66(1), 1–9.
- Reddy B, and Jagadish JS. 1989. Properties of soil-cement block masonry. *Masonry International*, 3(2), 80–84.
- Reddy B, and Kumar PP. 2009. Role of clay content and moisture on characteristics of cement stabilised rammed earth. In *Proceedings of the 11th International Conference on Non-Conventional Materials and Technologies (NOCMAT)*. Bath University.
- Reddy B, and Kumar PP. 2010. Embodied energy in cement stabilised rammed earth walls. *Energy and Buildings*, 42(3), 380–385.
- Reddy B, Lal R, and Rao KN. 2007. Optimum Soil Grading for the Soil-Cement Blocks. *Journal of Materials in Civil Engineering*, 19(2), 139–148.
- Schroeder H. 2016. *Sustainable Building with Earth*. Cham: Springer International Publishing.
- Spence RJS. 1975. Predicting the performance of soil-cement as a building material in tropical countries. *Build. Sci.*, 10, 155.
- UN Bulletin No. 4. 1950. *Housing, Town and Country Planning*. New York: United Nations.
- UNHCS. 1976. *Report of HABITAT, A/CONF.* Vancouver.
- UNIDO. 1980. *Appropriate Industrial Technology for Construction and Building Materials. Monographs on Appropriate Industrial Technology, No.12*. New York: UNIDO.
- Vyncke J, Kupers L, and Denies N. 2018. Earth as Building Material - An overview of RILEM activities and recent Innovations in Geotechnics. *MATEC Web of Conferences*, 149, 1–7.
- Walker P. 2002. *Standards Australia, 2002. HB 195: The Australian Earth Building Handbook*.
- Walker P, and Stace T. 1997. Properties of some cement stabilised compressed earth blocks and mortars. *Materials and Structures/Materiaux et Constructions*, 30(203), 545–551.
- Webb D. 1983. Stabilized soil construction in Kenya. In *International conference on economical housing in developing countries*. Paris: UNESCO.
- Webb D. 1994. Stabilised soil and the built environment. *Renewable Energy*, 5(5–8), 1066–1080

# Chapter 2

## Literature Review

### 2.1 Chapter introduction

In this thesis, bio-stabilisation is employed for the development of new earthen construction materials for techniques such as rammed earth and compressed earth blocks. Here a historical overview of these techniques is presented and along with their construction procedures, suitable soils and desired engineering properties are discussed. Earthen construction materials which are essentially compacted soil can be understood considering it in terms of unsaturated soil mechanics (Jaquin et al., 2009); hence, subsequent sections in this chapter gives an overview of the basics of soil mechanics and unsaturated soil mechanics. Finally, the chapter concludes with literature focussing on the chosen bio-stabilisation technique, i.e. *biopolymer stabilisation*.

### 2.2 Earthen construction techniques

#### 2.2.1 Rammed earth wall construction

##### 2.2.1.1. Overview of rammed earth construction

Rammed earth construction is one of the most widely used earthen construction techniques across the world. A detailed chronological study on historic rammed earth structures scattered around the world suggests that rammed earth construction may have originated independently in ancient China and Mediterranean, and later spread throughout the world with human migration (Jaquin et al., 2008). Studies on these traditional earthen constructions have led to the development of design guidelines for the present-day rammed earth construction.

In China, though rammed earth structures existed in the late Neolithic period (2000-3000 BC), Schroeder (2016) suggests that Fu Yueh, a minister in Shang Dynasty's (around 1320 BC) was the first "rammed earth master builder". Excavations at Shang Dynasty capital in Anyang, Henan Province have revealed a rammed earth wall 70 m long and 2-4 m thick (Houben and Guillaud, 1994). Later, rammed earth construction techniques spread across Henan and Shandong provinces under Zhou and Qin dynasties. It is during this era that sections of the Great Wall of China were initially built using rammed earth technique (Beckett, 2011). Houben and Guillaud (1994) mention that the 'true' rammed earth technique using formwork was constructed during the Three Kingdoms period (221-581 AD). The Tang Dynasty developed many cities with fortified rammed earth walls along the Silk Route (Jiyao and Weitung, 1990). For instance, the Tang Fort of Baishui, located at the western end of the Silk Route is solely constructed using rammed earth techniques (Jaquin et al., 2008). Regulated trade might have led to the development of rammed earth structures with Japan; a classic example is the

## Chapter 2. Literature review

---

renowned Buddhist monastery in Horyuji (607 AD), the earliest known rammed earth structure in Japan). Later, the rise of the Ming Dynasty (1368-1644 AD) after the fall of the Jin empire led to Chinese expansionism. This expansion led to the development of rammed earth structures across China (Jaquin et al., 2008). The largest and most well-known sections of the Great Wall using rammed earth techniques were built during this period. Later, the use of rammed earth technology spread across Asia. Historic rammed earth structures are found in Himalayan regions like Tibet, Bhutan, Nepal and India (Jaquin et al., 2008).



Figure 2.1. Rammed earth portion of The Great Wall of China at Gansu, China. Photo retrieved from <https://www.murailledechine.com/voyage-jiayuguan-gansu>

In the Mediterranean, it seems that rammed earth was initially used in Phoenician settlements, where excavations have revealed the use of rammed earth construction. This seems to be independent of the rammed earth technique developed by the “oasis dwellers’ of North Africa (Michon, 1990). Excavations of third century AD sites reveal many rammed earth walls in Southern France (Houben and Guillaud, 1994). In the eighth century, there was a re-introduction of rammed earth construction through the Muslim invasions in Europe and North Africa. The Almoravid and Almohad Berber Dynasties, that originated from the Sahara and ruled North Africa and Iberia, used rammed earth extensively (Jaquin et al., 2008), and example being the city walls and El Badi Palace constructed in 1578 in Marrakesh, Morocco. Much of the vernacular architecture in Morocco at that time used rammed earth construction techniques. After the fall of Muslim rulers in 1492, the Christian rulers employed Muslim artisans and

## Chapter 2. Literature review

---

craftsmen and used rammed earth techniques which later spread across Spain. In Spain, rammed earth was used for military buildings and this vernacular architecture lasted until the end of nineteenth century (Font and Hidalgo, 1991; Gerrard, 2003). Colonial expansion to North and South America, Australia and New Zealand led to the introduction of rammed earth structures in these countries. Prior to colonial expansion, there were no reported earth structures in these countries (Beckett, 2011). Around 1556 AD, colonists built the first rammed earth structure in North America at St Augustine, Florida. Subsequently, the use of rammed earth construction spread across North America with colonisation between 1607 and 1703. Colonists also took rammed earth construction to northern regions of South America. In São Paulo, the cathedral of Taubaté was built in 1645 using the rammed earth technique (Jaquin et al., 2008). Subsequently, many rammed earth structures were built in São Paulo, where it was the most widely used construction technique between the 18<sup>th</sup> and 19<sup>th</sup> century. European explorers introduced rammed earth construction technique to Australia and New Zealand. Similar to America, rammed earth construction spread across the Australian continent with colonial expansion.



Figure 2.2. Chapel of Reconciliation in Berlin, Germany, Photo by Reitermann (2001)

In late 18<sup>th</sup> century and throughout the 19<sup>th</sup> century, there was a strong revival of earthen construction due to the initiative of the Lyonnais architect and professor Francois Cointeraux. Cointeraux conducted several experiments on rammed earth technique and detailed the specification for constructing earthen building in this publication “*Ecole d’Architecture Rurale*”

---

(1791). This later led to dissemination of earthen construction in Europe, United States of America and Australia (Gallipoli et al., 2017). In the early 20<sup>th</sup> century, the interest in earthen materials was primarily to develop low-cost buildings. However, with its aesthetic appeal, rammed earth is recognized by various architects across the globe. From the early 21<sup>st</sup> century, countries like Australia, New Zealand, United States of America, Canada, India, and many European countries have seen the construction of rammed earth buildings. With better construction quality and technology, modern rammed earth structures have seen several innovations. With better ramming equipment, modern rammed earth walls are thinner and taller, while flexible formwork has paved the way to curved walls (Niroumand et al., 2012; Wallis, 2012). With these developments, many modern rammed earth structures have been constructed across the globe. Some examples are the Chapel of Reconciliation in Germany, the Naked Stables Private Reserve in China and the Nk'Mip Desert Cultural Center in Canada (Krayenhoff, 2012; Niroumand et al., 2012; Wallis, 2012). Figure 2.2 shows the first of these which is an iconic representation of the reunion of East Germany and West Germany and is constructed using rammed earth techniques.

### 2.2.1.2. Construction procedure for a rammed earth wall

Figure 2.3 illustrates a typical onsite construction sequence of a rammed earth wall. Traditionally, rammed earth walls were constructed using the sub-soil available at the site, however, modern rammed earth tends to adhere to strict guidelines delineating the desired soil properties. A detailed section on desired soil properties appears later in this chapter. Generally, a well-graded soil mixture consisting of 50-80% sand and gravel, 10-30% silt and 5-20% clay is preferred (Walker et al., 2005). Initially, all the ingredients, i.e. sand, gravel and fines (silt and clay) are dry mixed thoroughly. For stabilised versions, the required quantity of the chemical stabiliser (cement and/or lime) is introduced to this dry mixture. A predetermined quantity of water is then added to this mixture and mixed thoroughly either manually or through mechanised mixing. Each rammed earth wall is manufactured as a collection of large blocks, with each block prepared with layers of compacted earth within formwork. The formwork is made of sturdy material and is ensured plumb through vertical supports. The moist soil mixture is introduced into this formwork arrangement and rammed into layers until the desired density is achieved. Ramming is done either through hand-held rammers or pneumatically powered tampers (Niroumand et al., 2012).

The process of introducing the soil mixture into the formwork and ramming is done until the maximum height to which the wall can be compacted within the formwork (lift). Usually the first lift of wall is constructed onto an earthen foundation or concrete stem wall depending upon the design specifications. Once a lift is completed, the formwork is loosened and re-mounted on top of the freshly rammed wall section. The process of introducing the moist soil mixture into the formwork, ramming it up to lift height and re-mounting of formwork is repeated till the

---

required wall height is achieved. Once the wall is completed, the formwork is removed and wall is left to dry to gain strength. In the case of stabilised rammed earth walls, where cement or lime is used to achieve design strength, suitable curing techniques are employed.

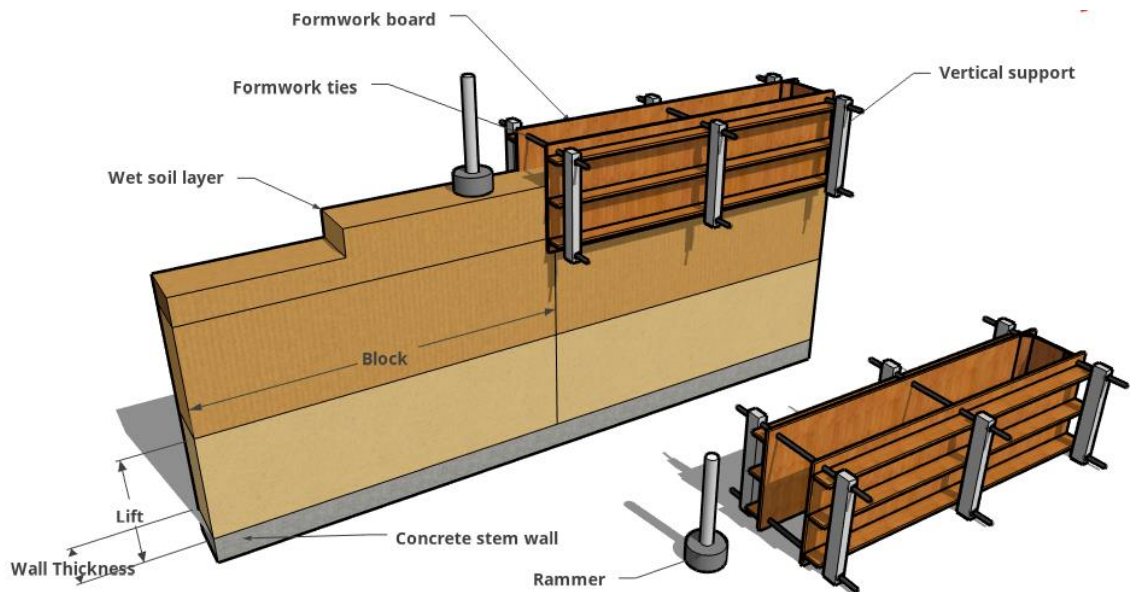

Figure 2.3. Illustration of rammed earth wall construction

### 2.2.2 Compressed earth blocks

#### 2.2.2.1. Overview of compressed earth blocks

Compressed earth blocks (CEBs) are the modern variant of the hand moulded “*Adobe*” blocks. Compared to adobe blocks which have a history of about 9000 years, CEBs are relatively newer forms of earthen materials. In the 18<sup>th</sup> century, the concept of manufacturing earthen blocks using a wooden press became popular in Europe (Deboucha and Hashim, 2011; Vyncke et al., 2018). However, the pivotal point for compressed earth blocks came with the invention of a small mechanical press CINVA-RAM by engineer Raul Ramirez at Inter-American Housing and Planning Centre (CINVA), Bogota, Colombia (Webb, 1983; Reddy et al., 2007; Deboucha and Hashim, 2011). In the United Nations Conference on Human Settlement held in Vancouver Assembly, CEBs were promoted as alternative low-cost walling units (UNHCS, 1976; Kerali, 2001). Since this promotion, CEBs have been considered as a low-cost alternative to conventional fired bricks and have been used extensively in many countries across Asia, North America and Africa. CEBs later adopted soil stabilisation, leading to the development of Cement Stabilized Blocks (CSBs), which have comparable mechanical and other performances to that of traditional fired bricks. Many pilot housing projects were undertaken using CSBs manufactured using the CINVA-RAM (Fullerton, 1967; Selvanayagam, 1970; Moriarty et al., 1975; Spence, 1975; Hughes, 1983). The houses constructed using CSBs were found to have better inner climatic conditions than modern materials (Fullerton, 1967; Hughes, 1983). However, these projects

reported concerns over long-term durability of CSBs. Subsequently, importance was given to both compression and stabilisation which led to the development of Compressed Stabilized Earth Blocks (CSEBs). Modern variants of block making presses such as ASTRAM, CETA-Ram, CTA Triple-Block Press developed improved the compacting effort during the manufacture of the blocks (Webb, 1983; Mukerji, 1986). Furthermore, many completed automated production units which manufacture CSEBs of different sizes and shapes were developed (Rigassi, 1985). With regards to stabilisation, many research studies have documented the role of different stabilisers in preparing CSEBs with improved strength and durability performances (Fitzmaurice, 1958; Olivier and Mesbah, 1987; Houben and Guillaud, 1994; Reddy and Jagadish, 1995; Walker and Stace, 1997; Reddy and Kumar, 2009; Nagaraj et al., 2016). With this evolution, earthen blocks of these types now are formidable competitors to traditional fired bricks.

### 2.2.2.2. Manufacturing procedure for compressed earth blocks

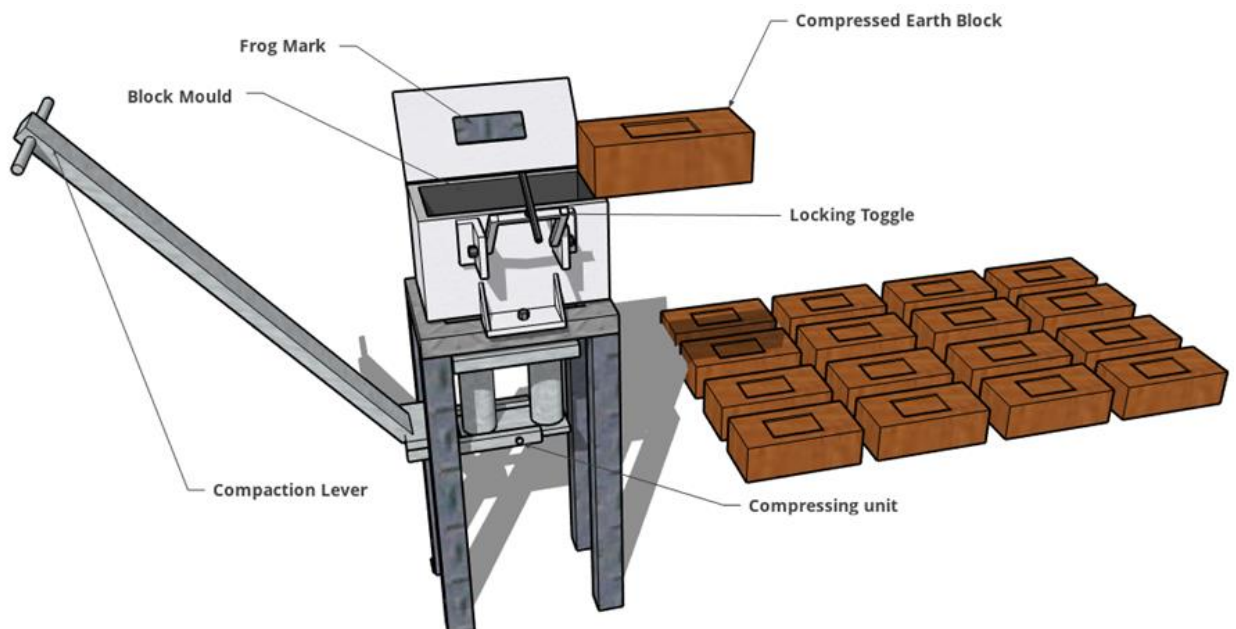

Figure 2.4. Illustration of manufacturing compressed earth blocks

Preparation of CEBs involves batching, mixing, placing the mix, compaction, ejection and curing of the blocks. The required quantities (mass basis) of the ingredients namely, soil components and the stabilizer (in case of CSEBs) are initially mixed in the dry condition. Similar to rammed earth walls, a well-graded soil mixture consisting of 50-80% sand and gravel, 10-30% silt and 5-20% clay is preferred for making compressed earth blocks (Walker et al., 2005). Stabiliser content for CSEBs varies in range of 7-12% of the soil mass (Fitzmaurice, 1958; Spence, 1975; Bryan, 1988; Reddy and Jagadish, 1989; Houben and Guillaud, 1994; Walker and Stace, 1997; Ciancio and Boulter, 2012). A pre-determined water which is sufficient enough to make the soil mixture mouldable is sprinkled on the dry mix and thoroughly mixed until a uniform

distribution of moisture is achieved. Then the wet mix is transferred into the mould and manually remoulded inside to ensure the required bulk mass for a block fits inside the mould. Then, the lid of the mould is closed and properly locked at the top. Using the toggle lever mechanism, the mix is compressed to give the designed compactive effort. It is ensured that the compaction of the blocks is undertaken within 15 minutes of wet mixing. The soil block is then ejected out of the mould by opening the top lid (Figure 2.4). The ejected blocks are stacked for curing to achieve the desired strength. CSEBs can be manufactured using manual or mechanised presses or can have dedicated production units. Based on the technique employed the daily production output varies. Theoretical outputs of different manufacturing processes are presented in Table 2.1.

Table 2.1. Theoretical manufacturing output of CEBs (Rigassi, 1985).

| Sl. No | Production type         | Theoretical Output / day |
|--------|-------------------------|--------------------------|
| 1      | Manual presses          | 300 - 1500               |
| 2      | Motor-driven presses    | 1000 - 5000              |
| 3      | Mobile production units | 1500 - 4000              |
| 4      | Fixed production units  | 2000 - 10000+            |

### 2.2.3 Suitable soils for earthen materials

This section discusses different guidelines which evaluate the suitability of soil used for modern earthen construction materials. The soil of interest is generally scrutinised for its particle size distribution and the effect of the dominant clay mineral present in the soil.

#### 2.2.3.1. Particle size distribution

Sub-soil is essentially made of different components namely, gravel, sand, silt, clay or a mixture of these components. In an earthen material both gravel and sand act as a skeleton for the earthen material, while silt fills in the voids making the material dense, and clay provides the necessary bonding. To obtain a stronger earthen material, the proportion of the clay component needs to be optimum (Etzion and Saller, 1987). However, high proportions of clay lead to excessive shrinkage and cracking on drying due to its sensitivity to water. Hence, arriving at the right combination of these soil components is the primary objective in the design of any earthen material. Ideally, an earthen construction material should contain high proportions of sand and silt, while an adequate quantity of clay to act as a binder (Maniatidis and Walker, 2003). Several researchers have attempted to define suitable proportions of soil components for different earthen materials based on laboratory trials and field implementations. Based on these experiences many countries have come up with technical standards, normative or technical documents. Jiménez Delgado and Guerrero (2007) reviewed more than 20 technical documents

---

concerning soil suitability for unstabilised earthen materials. The documents included technical standards and normative documents of different countries, and technical recommendations from different researchers. This review concluded that clay content should be in a range of 10-22% for CEBs and 10-15% for rammed earth. Figure 2.5 presents limits of particle size distributions for both compressed earth blocks and rammed earth as recommended by various standards (MOPT, 1992; Houben and Guillaud, 1994; CRATerre-EAG: Rigassi, 1995; CRATerre-EAG., 1998; AFNOR, 2001). Table 2.2 tabulates the recommended soil proportions by different researchers. Though there are anomalies between these recommended values, the most recommended soil proportion is one containing a high sand content at about 70% and a fine fraction (silt and clay) of about 30% (Maniatidis and Walker, 2003).

In the case of stabilised earthen construction, the recommended soil proportions vary slightly due to the addition of the stabiliser. In modern earthen construction, cement is the most popular amongst a variety of stabilisers used. Due to the better stabilising effect of cement with sand grains, cement stabilised earthen materials tend to have higher sand and gravel and lower fine fractions (Maniatidis and Walker, 2003). Table 2.3 presents recommended soil proportions for cement stabilised rammed earth and compressed earth blocks.

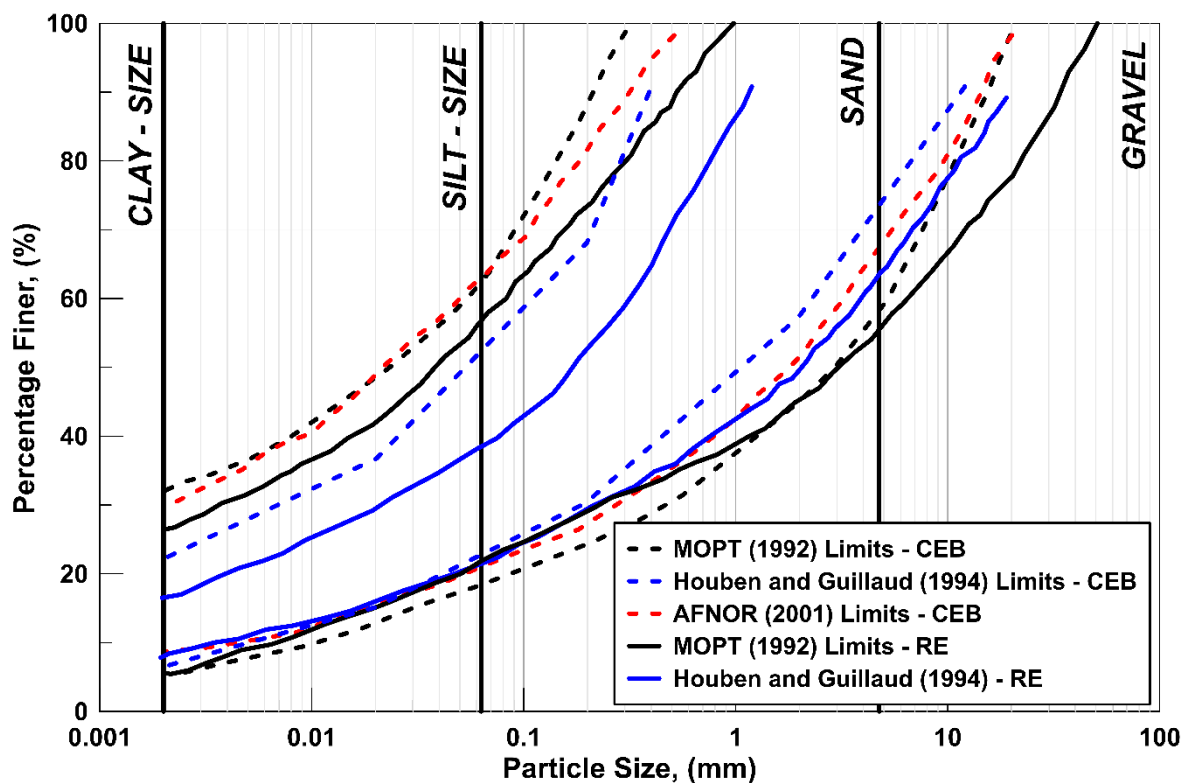

Figure 2.5. Recommended particle size distribution for rammed earth and compressed earth blocks

Table 2.2. Recommended soil proportions for unstabilised earthen materials

| Techniques             | Reference                             | Clay  | Silt  | Sand  | Gravel |
|------------------------|---------------------------------------|-------|-------|-------|--------|
| Rammed earth           | Alley(1948)                           | 25-30 | 50-80 | 10-20 |        |
|                        | McHenry (1984)                        | 30-35 | -     | 65-70 |        |
|                        | Etizon and Saller (1987) <sup>1</sup> | 0-20  | 0-50  | 50-80 | -      |
|                        | Etizon and Saller (1987) <sup>2</sup> | 20-30 | 50-80 | 0-30  | -      |
|                        | Smith and Austin (1989)               | 4-15  | 40    | 60-80 | -      |
|                        | Houben and Guillaud (1994)            | 0-25  | 10-30 | 45-75 |        |
|                        | Norton (1997)                         | 10-25 | 15-30 | 65-70 |        |
|                        | SAZS 724 (2001)                       | 5-15  | 15-30 | 50-70 |        |
|                        | McHenry (1984)                        | 4-15  | 32    | 30    | 23     |
|                        | Etizon and Saller (1987) <sup>1</sup> | 0-20  | 0-50  | 50-80 | -      |
| Compressed earth block | Etizon and Saller (1987) <sup>2</sup> | 20-30 | 50-80 | 0-30  | -      |
|                        | Smith and Austin (1989)               | 4-15  | 40    | 60-80 | -      |
|                        | Houben and Guillaud (1994)            | 6-22  | -     | -     | -      |

### 2.2.3.2. Plasticity and Shrinkage properties of earthen construction material

#### a) Clay mineralogy

Clay is an integral part of any earthen construction material. As a fine particle with effective size less than 0.002mm, the effect of gravity on a clay particle is negligible compared to that of the electrical forces acting on its surface (Terzaghi et al., 1963). Depending on the chemical composition of the clay there is chemical interaction with active minerals. During the preparation of an earthen construction material, the clay fraction in the soil mixture readily reacts with water. This interaction provides the initial bonding with the inert soil fractions (i.e., gravel, sand and silt). In the case of stabilised earthen materials, the stabilisers chemically interact with clay particles to form cementitious bonds.

The chemical composition of clay particles enables them to interact with the environment attracting moisture to their surfaces readily. This property plays a vital role in the hygroscopic behaviour of the earthen material (McGregor, Heath, Shea et al., 2014). On the other hand, the physical and chemical properties of the clay fraction affect the volumetric stability of the earthen materials. Cycles of drying/wetting due to environmental conditions lead to the shrinkage/swelling of clays within the earthen material thus leading to reduction of

## Chapter 2. Literature review

strength and stiffness (Fabbri et al., 2018). The shrinkage/swelling of the earthen materials is directly related to the chemical composition of the clay fraction.

Table 2.3. Recommended soil proportions for cement stabilised earthen materials

| Techniques             | Reference                  | Clay  | Silt  | Sand       | Gravel |
|------------------------|----------------------------|-------|-------|------------|--------|
| Rammed earth           | Verma and Mehra(1950)      | -     | -     | >35        | -      |
|                        | United Nations (1964)      | 20-55 | -     | 45-80      | -      |
|                        | Gooding (1993)             | 10-25 | 15-25 | 45-90      | -      |
|                        | Montgomery (1998)          | 15-25 | 10-30 | 40-75      | -      |
|                        | Standards Australia (2002) | 25    | 15    | 45         | -      |
|                        | Walker et al (2005)        | 5-20  | 10-30 | 45-80      | -      |
| Compressed earth block | Fitzmaurice (1958)         | 5-20  | -     | 20 Minimum | -      |
|                        | United Nations (1964)      | 10-25 | -     | -          | -      |
|                        | Spence(1975)               | <35   | -     | -          | -      |
|                        | VITA(1975)                 | 5-30  | -     | ≥33        | -      |
|                        | Norton (1997)              | 10-25 | -     | -          | -      |
|                        | Olivier and Mesbah (1987)  | 20    | -     | 70         | -      |
|                        | Reddy and Jagadish (1995)  | -     | -     | 70 ± 5     | -      |
|                        | Walker (1995)              | 20-35 | -     | 70-85      | -      |
|                        | Walker and Stace(1997)     | 15-30 | -     | -          | -      |
|                        | Reddy et al (2007)         | 14-16 | -     | -          | -      |
| Reddy and Latha (2014) | 10-14                      | -     | -     | -          |        |

Clay minerals are crystalline hydrous alumino-silicates having a lattice structure in which the atoms are arranged in the form of layers. The arrangement of these layers and the chemical composition of these layers determine the type of clay mineral (Terzaghi et al., 1963). The basic units of a clay mineral are silica tetrahedra and alumina octahedra. Different arrangements of these basic units produce different clay minerals. *Kaolinite*, *Illite* and *Montmorillonite* are the most commonly occurring clay minerals in soils. A unit of *kaolinite* consists of a single layer silica tetrahedron layer and a single layer of alumina octahedron. *Illite* has 2:1 sandwich of a tetrahedron– octahedron–tetrahedron layers, with poorly hydrated potassium cations in between. A unit of *montmorillonite* is similar to *illite*; however, calcium and sodium ions are situated at the exterior of the sheets. Amongst these three clay minerals, *kaolinite* has the least affinity to water and is less susceptible to volume changes, while

*montmorillonite* has the highest affinity to water and is most susceptible to volume changes. Hence, an ideal soil for making earthen material usually contains a clay fraction high in *kaolinite*, and the least desirable will contain *montmorillonite* (Etzion and Saller, 1987). A natural soil may consist of all these clay minerals, but the predominant clay mineral controls the clay behaviour. To understand the effect of the predominant clay mineral and to assess the suitability of the soil, plasticity and shrinkage properties of the soil are determined.

b) Plasticity properties of earthen construction material

When a soil slurry consisting sufficient clay portion starts drying, it passes from the liquid state through a plastic state and finally into a solid state (Terzaghi et al., 1963). The transition of the soil from one state to another occurs at critical values of water content. In geotechnical engineering, water content of the soil is defined as the ratio of mass of water to the mass of soil solids in a given mass of soil. The water content at which the transition of the soil takes place from a plastic state to a liquid state is the *liquid limit*, while the minimum water content required to make the soil plastic is the *plastic limit*. These limits are commonly referred to as Atterberg limits. Between these two limits, the soil behaves as a plastic material, i.e. it deforms continuously in ductile fashion. This range of water content between liquid and plastic limits is referred to as the *plasticity index* and is dependent on the clay minerals present in the soil. To determine the soil plasticity, the numerical values of plasticity index are plotted against the liquid limit on a plasticity chart which categorises the soil into different categories of plasticity, a standard practice in the classification of soils in geotechnical engineering (BS 1377-2, 1990). In their review, Jiménez Delgado and Guerrero (2007) noted that very few recommendations were available in the literature in regards to soil plasticity. Figure 2.6 presents the recommended range of soil plasticity for unstabilised rammed earth and compressed earth blocks (Houben and Guillaud, 1994; CRATerre-EAG., 1998; AFNOR, 2001).

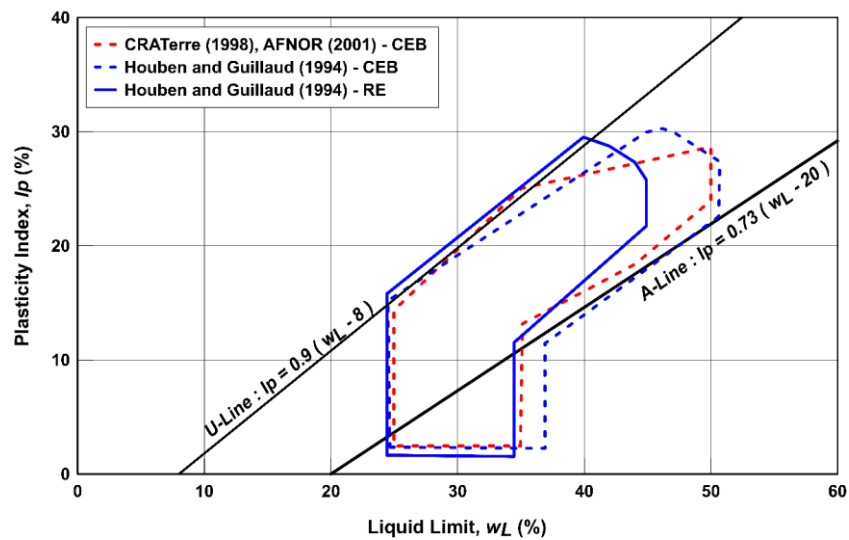

Figure 2.6. Recommended soil plasticity range for rammed earth and compressed earth blocks

For cement stabilised earthen materials, the recommended soil plasticity properties vary due to the addition of the stabiliser. The average recommended liquid limit of the soil used for cement stabilised earthen construction materials is 30-40%, while the plasticity index is 15-20%. Recommended plasticity properties of cement stabilised earthen materials are tabulated in Table 2.4.

Table 2.4. Recommended plasticity properties for cement stabilised earthen materials

| <b>Techniques</b>      | <b>Reference</b>           | <b>Liquid limit (%)</b> | <b>Plasticity Index (%)</b> |
|------------------------|----------------------------|-------------------------|-----------------------------|
|                        | Verma and Mehra(1950)      | <25                     | 8.5-10.5                    |
|                        | IS 2110 (1980)             | <27                     | 8.5-10.5                    |
| Rammed earth           | Houben and Guillaud (1994) | 25-50                   | 10-25                       |
|                        | Walker (2002)              | 35-45                   | 10-30                       |
|                        | Walker et al (2005)        | <45                     | 2-30                        |
| Compressed earth block | Fitzmaurice (1958)         | <40                     | 2.5-22                      |
|                        | Spence(1975)               | -                       | <20                         |
|                        | Walker (1995)              | -                       | 5-15                        |

### c) Shrinkage properties of earthen material

Unlike particle size distribution and plasticity properties, studies on classifying soils based on shrinkage properties for earthen construction are limited. Soils having clay minerals which undergo excessive shrinkage/swelling lead to cracks and should be avoided in earthen construction (NZS 4298, 1998). Cracks are a concern to an earthen material in terms of durability and more particularly for rammed earth considering its monolithic nature. While early studies attempted to understand the shrinkage characteristics of the manufactured earthen materials (Walker, 1995), subsequent studies have tended to categorise soils based on the shrinkage properties (Walker et al., 2005). Burroughs (2008, 2010) undertook a detailed study in classifying suitable soils for rammed earth construction based on soil gradation, plasticity and shrinkage properties. Figure 2.7 illustrates the steps in determining soil suitability for rammed earth construction based on this study. It can be observed from the figure that, based on the linear shrinkage and plasticity index values of the soil, the probability of constructing rammed earth walls that meet or exceed a compressive strength criterion of 2 MPa can be evaluated. This would eliminate the necessity of determining unconfined compressive strength of the soil in order to evaluate its suitability in preparing earthen construction material. Further, Burroughs (2010) categorised favourable soils into four categories and

recommended the required stabiliser content needed to achieve the compressive strength criterion of 2 MPa. Research findings from these studies suggests both plasticity and shrinkage properties of the soil would be sufficient not only to categorise the suitability of soil for preparing earthen construction materials, but also arrive at the required stabiliser content for stabilisation.

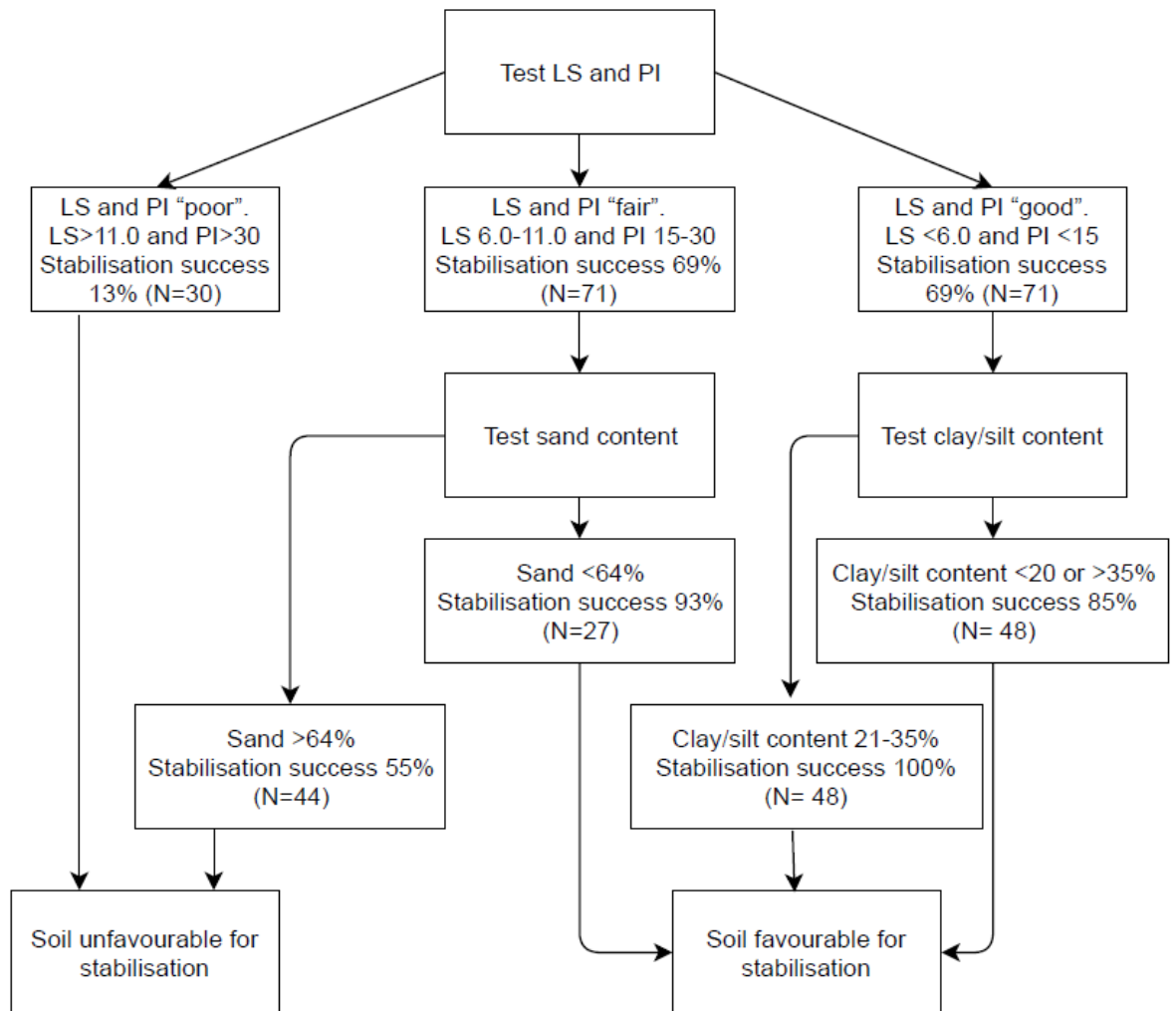

Figure 2.7. Illustration as presented by Burroughs (2008) to determine the suitability of soils for rammed earth construction based on particle size gradation, plasticity and shrinkage properties

### 2.2.4 Desired engineering properties of earthen material

This section discusses the different desired engineering properties of earthen construction material namely strength characteristics, durability and hygroscopic properties, and recyclability potential.

### 2.2.4.1. Strength characteristics of earthen material

Strength is the most common parameter used to assess the performance of earthen construction material. Similar to concrete and masonry units, evaluation of earthen materials is mostly done through the determination of compressive strength (Walker, 1997; Jean Claude Morel et al., 2007; Aubert et al., 2016). Compressive strength is the most commonly used test method primarily due to the relatively simple procedures needed to obtain values. It also provides valuable insights in forecasting the durability performance of the material (Reddy and Jagadish, 1995). Along with compressive strength, tensile, flexural or shear strengths are also sometimes used to evaluate the suitability of earthen construction materials.

Factors like density, placement water content, compaction and stabiliser content define the strength characteristics of an earthen material. Many studies have attempted to understand the influence of these factors (Houben and Guillaud, 1994; Walker, 1995; Jean Claude Morel et al., 2007; Kouakou and Morel, 2009; Reddy and Kumar, 2011a, 2011b). Based on twenty years of consistent test data, Houben and Guillaud (1994) reported a strong relationship between compressive strength and density of compressed earth blocks. Walker (1995) studied the strength characteristics of cement stabilised earth blocks prepared with eleven modified soils having a broad spectrum of plasticity. Soil-cement blocks treated with three different cement-soil ratios were prepared for each modified soil and each were tested for saturated compressive strength. For a given combination with a sample size of ten blocks, the saturated compressive strength showed an increasing trend with increasing block density. Morel et al., (2007) showed that the compressive strength of unstabilised and cement stabilised soils had similar increasing trends with density. International standards such as IS 1725 (2013) recommend manufacturing compressed earth blocks under controlled density signifying the prominent relation between density and strength.

Reddy and Kumar (2011a, 2011b) undertook an extensive study to understand the effect of compaction characteristics, placement water content and stabiliser content on the strength characteristics of cement stabilised rammed earth. Five soils of varying soil gradation and three stabiliser contents (5%, 8% and 12%) were chosen for this study. Compaction characteristics (i.e. maximum dry density (MDD) and optimum water content (OWC)) for the five soils and all cement treated combinations were determined. To establish a relation between dry density, placement water content and compressive strength, cylindrical specimens of 76mm height and 38mm diameter with different water contents were prepared. It is interesting to note that in this study compressive strength not only showed a strong relation to the density of the material but also to the placement water content (Figure 2.8).

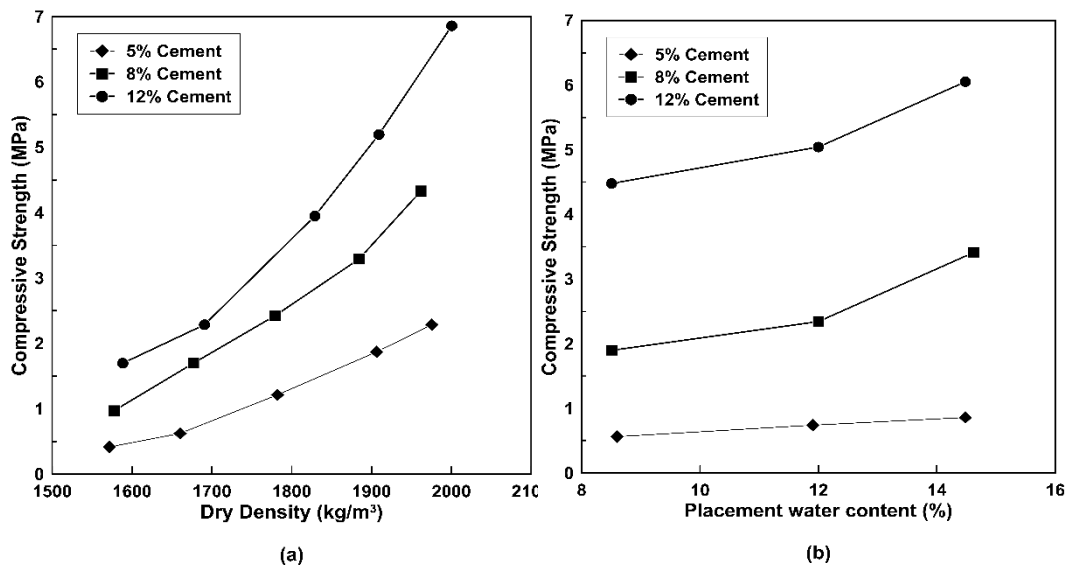

Figure 2.8 Relationship of wet compressive strength with (a) dry density and (b) placement moisture content (Reddy and Kumar, 2011a)

Also, in this study, cement stabilised rammed earth prisms (150mm x 150mm x 300mm) were manufactured for a particular soil for different densities and stabiliser contents (5%, 8% and 12%) and different mechanical properties were determined. It was noted that mechanical behaviour was strongly related to the dry density of the earthen material and stabiliser content. (Figure 2.9). The results from these studies clearly indicate that the strength characteristics of earthen materials are in direct relation to density, stabiliser content and placement conditions.

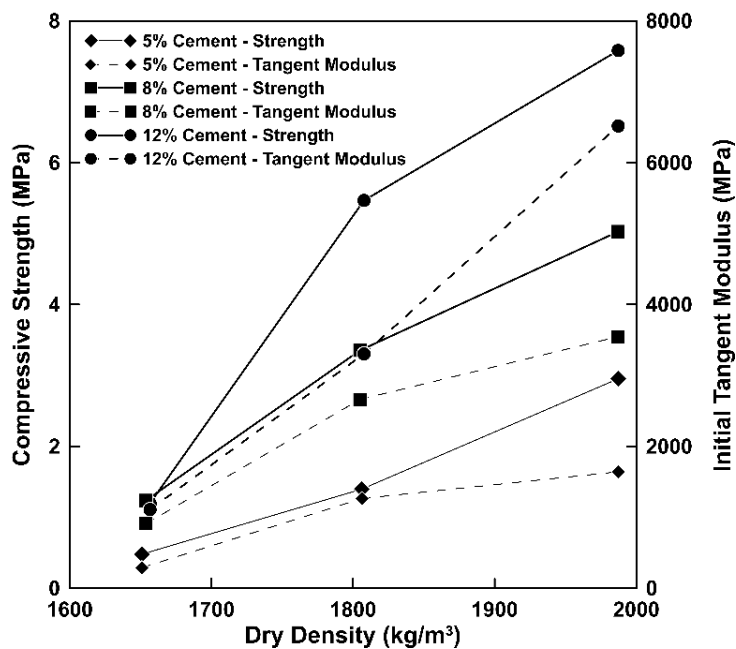

Figure 2.9 Relationship between mechanical properties of earthen material with dry density and stabiliser content (Reddy and Kumar, 2011b)

As the dry density of the earthen material is dependent on compaction energy during the manufacture of the earthen material, a few studies have analysed the influence of compaction pressure on the mechanical behaviour of earthen materials (Olivier and Mesbah, 1986; Bruno et al., 2016). Olivier and Mesbah (1986) studied the effect of compaction pressure on the mechanical properties of earthen construction materials. Cylindrical samples of diameter 11 cm and height 11 cm were prepared for different compacting pressures from 1.2 to 10 MPa. It was reported that higher compaction pressure increased the maximum dry density of the soil and in turn, the compressive strength indicating higher compacting pressures would help in preparing earthen materials with better strength. Recently, Bruno et al.,(2016) investigated the mechanical behaviour of hyper-compacted earthen blocks compacted at high pressures in the range of 25 to 100 MPa developing of earthen construction materials of high density. It was reported that the mechanical properties, i.e. stiffness and strength improved with compacting pressure (Figure 2.10).

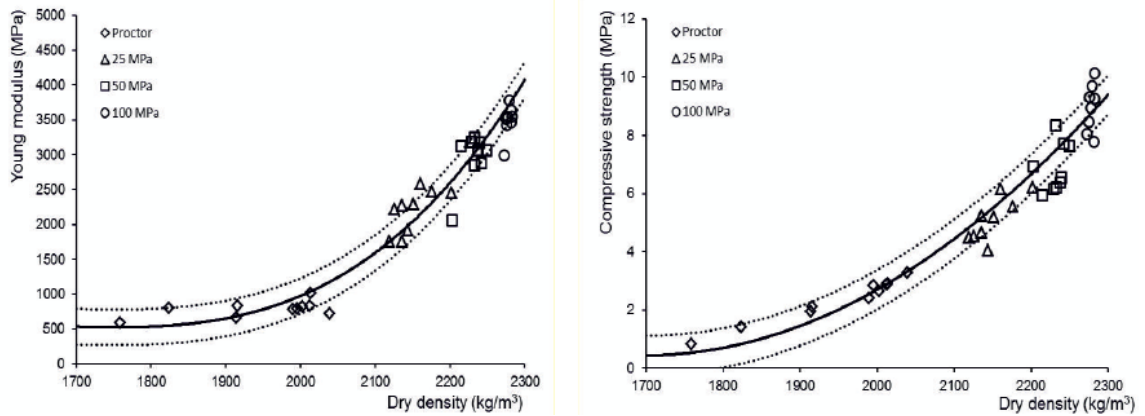

Figure 2.10 Variation of stiffness and strength of earthen materials for different compacting pressures (Bruno et al., 2016)

The determination of the compressive strength is also affected by the testing procedure adopted. As indicated in Morel et al., (2007), the compressive strength of earthen construction material is routinely determined through either direct unit strength tests, the RILEM test or indirect tests. The direct unit strength test is the determination of the compressive strength by crushing the earthen material in the direction of its compaction. The RILEM (1994) test estimates the compressive strength by halving the brick and stacking the two halves with a mortar joint, thus doubling the slenderness ratio of the sample, while the mortar joint replicates masonry construction. A few other indirect measures to estimate compressive strengths have been developed, primarily to assist in in-situ quality control (Morel et al., 2007). The three-point bending test is one type of indirect test which measures flexural strength and estimates compressive strength based on the flexural strength (Morel et al., 2007). Laboratory determined compressive strengths are also affected by the sample geometry. Typically, three different shapes have been considered for compressive strength tests, namely prismatic, cylindrical and

## Chapter 2. Literature review

cubical samples. In addition strengths for prismatic and cylindrical samples are affected by the specimen aspect ratio (Walker, 1997; Morel et al., 2007; Aubert et al., 2016). From the above discussions, it can be concluded that the estimation of compressive strength is affected by various physical properties of the earthen material and the test procedure adopted.

Table 2.5. Design and characteristic compressive strength for compressed earth blocks as per different national regulations

| Country     | Reference                          | Compressive strength (MPa) |                | Comments                                   |
|-------------|------------------------------------|----------------------------|----------------|--|
|             |                                    | Design                     | Characteristic |  |
| Germany     | DIN 18945 (2013)                   | -                          | 2.5-7.5        | For bricks Class 1-7                       |
| India       | IS 1725 (2013)                     | -                          | 3.5            | Cement stabilised                          |
| New Zealand | NZS 4297 (1998)<br>NZS 4298 (1998) | 0.5                        | >1.6           | For both unstabilised and stabilised units |

Table 2.6. Design and characteristic compressive strength for rammed earth as per different national regulations

| Country     | Reference                          | Compressive strength (MPa) |                 | Stabilisation condition                    |
|-------------|------------------------------------|----------------------------|-----------------|--|
|             |                                    | Design                     | Characteristic  |  |
| Australia   | CSIRO(1987)                        | 0.7                        | -               | Unstabilised                               |
|             | EBAA(2004)                         | 1.0                        | -               | Cement stabilised                          |
| Germany     | Lehmbau Regeln (2009)              | 0.3-0.5                    | -               |  |
| India       | IS 2110 (1980)                     | -                          | 1.4             | Cement stabilised                          |
| Spain       | MOPT (1992)                        | 0.2 (dry)<br>0.1(wet)      | 0.6-1.8         | Cement stabilised                          |
| Switzerland | SIA (1994)                         | 0.3-0.5                    | 2-4             | For both unstabilised and stabilised units |
| New Zealand | NZS 4297 (1998)<br>NZS 4298 (1998) | 0.5                        | >1.6            | For both unstabilised and stabilised units |
| USA         | CID-GCB-NMBC-14.7.4(2006)          | -                          | <2.07<br>>1.725 |  |

During actual earthen construction, the workmanship affects the physical factors which control the strength (Schroeder, 2016). In order to reduce the effects of workmanship and maintain quality, international standards specify either design or characteristic strengths of earthen material. Design or permissible strength is the factored strength arrived through

appropriate strength reduction considering the likely worst-case scenarios that may affect the earthen material. The characteristic compressive strength is the strength obtained from material testing. The recommended design and characteristic compressive strengths vary according to the standard of practice followed. Table 2.5 and 2.6 tabulates these recommended strengths for compressed earth blocks and rammed earth as per different international standards respectively.

### 2.2.4.2. Durability characteristics of earthen material

Ability to withstand environmental forces without disrupting the functional requirement of the structure is the durability performance of an earthen structure. Parts of the Great Wall of China, the Horyuji Temple in Japan and traditional rammed earth houses in France are time tested examples which display satisfactory durability performance (Bui et al., 2009). The durability performance of an earthen material is generally assessed through its ability to resist erosion against moisture ingress. Erosion would lead to the breakdown of aggregated soil particles (unstabilised or stabilised) leading to the degradation of the material (Beckett and Ciancio, 2016). It can be conjectured that the durability of traditional unstabilised earth structures was ensured through appropriate building design (suitable roof or basement avoiding capillary rise) which has enabled the longevity of these structures (Bui et al., 2009). Though these structures are time tested examples of earthen structures, traditional earthen construction materials fail to the requirement of modern-day durability standards. In order to comply with these durability requirements, modern earthen construction materials rely on chemical stabilisation. Several durability tests emulating rainfall induced erosion and capillary rise deterioration have been proposed to assess earthen materials (Heathcote, 1995; Morel et al., 2012). Drip tests, wire brush tests, and spray tests simulate erosion, while immersion, suction and contact tests assess the earthen material for capillary rise deterioration ( Morel et al., 2012).

In the literature, durability studies mainly deal with the performances of stabilised earthen materials. Walker (1995) investigated the durability characteristics of cement stabilised earth blocks prepared with soils having different plasticity properties, as discussed above in Section [2.2.3.2](#). Durability tests were conducted as per ASTM D559 (1989), and it was noted that soils with plasticity index below 15-20 performed adequately, while a higher cement content of 10% was needed for soils with a plasticity index above 25. Guettala et al., (2006) investigated the performance of stabilised compressed blocks (with cement and/or lime) both under laboratory confined testing and environmental exposure. It was noted that after four years, exposed walls of the test materials showed less sign of deterioration. Bui et al., (2009) investigated the durability characteristics of rammed earth walls which were exposed to natural weathering for 20 years. It was reported that the mean erosion depth was only 2 mm (0.5% wall thickness) for lime stabilised rammed earth walls, while it was 6.4 mm (1.6 % wall thickness) for unstabilised rammed earth walls. On extrapolation, the lifespan of these unstabilised

rammed earth walls was then determined to be about 60 years (Figure 2.11). Beckett and Ciancio (2016) obtained core samples from 32-year-old cement stabilised rammed earth (CSRE) walls and compared strength and durability properties with 28-day old rammed earth cores. It was noted that there was a significant loss of compressive strength in aged samples as compared to the freshly prepared samples. Furthermore, it was concluded that the rate of erosion was about 0.1 to 0.2 mm/year for CSRE when exposed to severe climatic conditions.

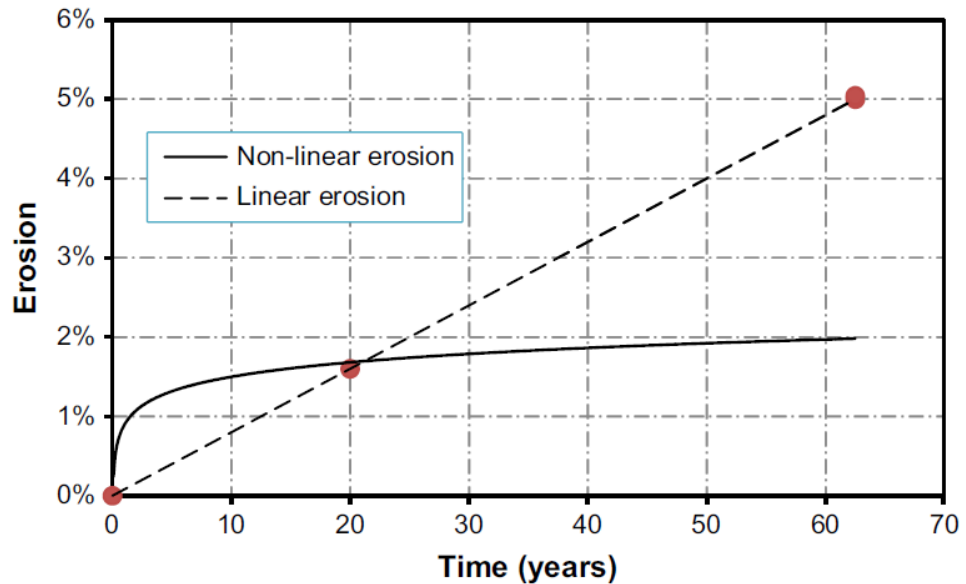

Figure 2.11 Extrapolation for unstabilised rammed earth wall (Bui et al., 2009)

Table 2.7. Recommended durability tests in practice in different countries

|                          | Reference        | Wire brush | Spray | Drip | Immersion | Contact | Suction |
|--------------------------|------------------|------------|-------|------|-----------|---------|---------|
| Brazil <sup>#</sup>      | NBR 13354(1996)  | √          |       |      |           |         |         |
| Indian <sup>#</sup>      | IS 1725 (2013)   | √          |       |      |           |         |         |
| Germany <sup>#</sup>     | DIN 18945(2013)  |            |       |      | √         | √       | √       |
| New Zealand <sup>§</sup> | NZS 4298 (1998)  |            | √     | √    |           | √       | √       |
| Spain <sup>#</sup>       | UNE 41410(2008)  | √          |       | √    |           | √       | √       |
| Sri Lanka <sup>#</sup>   | SLS 1382-3(2009) |            | √     |      |           |         |         |
| USA <sup>†</sup>         | ASTM D559 (1989) | √          |       |      |           |         |         |
| Zimbabwe <sup>*</sup>    | SAZ 724 (2001)   |            | √     | √    |           |         |         |

Note: <sup>#</sup> CEBs, <sup>\*</sup> RE, <sup>§</sup> both CEB & RE and <sup>†</sup>Soil-cement mixtures

Without the addition of cement as stabiliser, earthen construction materials would fail to pass some of the standard durability tests, and several researchers opine that these tests are too severe and unrealistic (Heathcote, 1995; Ogunye and Boussabaine, 2002; Guettala et al., 2006). Recently, Bruno et al., (2017) investigated the effect of alternative stabilisers on the

mechanical and durability properties of hyper-compacted earthen materials. The study employed immersion, contact and suction tests as prescribed by DIN 18945 (2013). The results indicated inclusion of alternative stabilisers improved durability deeming the material to be classed better than those of unstabilised material prepared using standard compaction. Many recommended durability tests are primarily aimed to assess cement stabilised earthen materials; however, use of these tests to assess earthen materials which are stabilised using alternative stabilisers may be inconclusive. Hence, based on the stabiliser chosen, and the proposed use of the material, an appropriate test procedure needs to be adopted. Table 2.7 presents preferred durability tests in practice in different countries.

### 2.2.4.3. Hygroscopic characteristics of earthen material

Hygroscopic properties of a building material determine the indoor air quality and humidity levels within a building. Padfield (1998) recognised that unfired clay masonry is one building material that has high potential to self-regulate indoor humidity levels. The experimental measurement of the hygroscopic behaviour of a building material is termed as the Moisture Buffering Value (MBV) or hygric inertia value and was originally proposed in the NORDTEST project (Rode, 2005). MBV is a single parameter which can be used to compare humidity buffering potential between building materials. The practical definition of  $MBV_{\text{practical}}$  as presented by Rode (2005):

*“The practical Moisture Buffering Value MBV indicates the amount of water that is transported in or out of a material per open surface area, during a certain period of time, when it is subjected to variations in relative humidity of the surrounding air. When the moisture exchange during the period is reported per open surface area and per %RH variation, the result is the  $MBV_{\text{practical}}$ . The unit for  $MBV_{\text{practical}}$  is  $\text{kg}/\text{m}^2 \text{ \%RH}$ ”*

Experimentally,  $MBV_{\text{practical}}$  is determined in an experimental setup where the material of interest is subjected to cycles of high and low humidity at a constant temperature. As in the literature, there are different proposed test procedures which differ in the recommended humidity levels and duration over which these humidity levels are maintained. Though there are many recognised procedures as prescribed by Fraunhofer IBP, Lund University, DIN standard, Japanese industrial standard and ISO standard to determine  $MBV_{\text{practical}}$ , the most common method used for earthen materials is the NORDTEST method (McGregor et al., 2016). In NORDTEST method, each cycle corresponds to an exposure of higher humidity of 75% RH for 8 hours and followed by lower humidity of 33% RH for 16 hours. For the stable cycle, the  $MBV_{\text{practical}}$  for a given material is determined by the following equation (2.1):

$$MBV_{\text{practical}} = \frac{\Delta m}{S \Delta \%RH} \quad (2.1)$$

were,  $\Delta m$  is change in mass of the sample due to change in relative humidity,  $S$  is the total exposure surface area and  $\Delta \%RH$  is difference between the humidity levels. Based on several round robin experiments, Rode et al., (2005) categorised different building materials having “negligible” to “excellent” hygroscopic behaviour. This categorization has helped subsequent research to compare hygroscopic behaviour of different building materials.

Detailed studies in understanding the hygroscopic behaviour of earthen construction materials are recent developments in earthen construction. Allinson and Hall (2012) investigated the hygroscopic behaviour of stabilised rammed earth materials with varying soil gradations. Three soil gradations denoted by 613, 433 and 703 were considered. (The designations indicate the respective soil proportions (e.g., 613 indicating 60% sand, 10% gravel and 30% fines by mass). Disc-shaped specimens of 105 mm diameter and 40 mm height were prepared for each gradation and cured for 28 days. After curing, the hygroscopic behaviour of these materials was characterised using the NORDTEST method. It was reported that samples took about five days to reach equilibrium and the stabilised rammed earth specimens had moisture buffering value in the range of 0.68 - 1.29 g/m<sup>2</sup> %RH which was higher than other conventional building materials such as gypsum boards and fired bricks which had moisture buffering value of 0.64 and 0.48 g/m<sup>2</sup> %RH respectively. Among earthen construction materials, samples with the highest sand content showed better performance indicating the importance of soil grading in the hygroscopic behaviour of earthen materials. Using similar testing procedures, McGregor et al., (2014) investigated the effect of clay mineralogy on the hygroscopic behaviour of earthen materials. Seven combinations of earthen materials with varying clay minerals namely kaolin, illite and smectite were considered. It was noted that the moisture buffering values of these earthen materials were in the range of 1.13 and 3.73 g/m<sup>2</sup> %RH. It was reported that the predominant clay mineral greatly influenced the MBV of the materials. Fine and active clay minerals like montmorillonite significantly contributed to moisture buffering but had secondary negative effects such as increased swelling and shrinkage. This study brings out the importance of the clay minerals in their contribution to forming the hygroscopic properties of earthen construction materials.

McGregor et al.,(2014) undertook a comparative study on the hygroscopic behaviour of unstabilised and stabilised compressed earth blocks. Different chemical stabilisers (cement, lime and sodium hydroxide) were used in this study. It was noted that unstabilised blocks had slightly better performance than the stabilised blocks. Within the stabilised versions, cement had performed better than lime and sodium hydroxide-stabilised earth blocks. Recently, Arrigoni et al.,(2017) undertook a study to understand the impact of stabilisation on the hygroscopic behaviour of rammed earth. Cement was used as a stabiliser in this study. It was reported that addition of the cement reduced the moisture buffering values of the stabilised rammed earth to 0.82 g/m<sup>2</sup> %RH, while the value for unstabilised rammed earth was 2.05 g/m<sup>2</sup>

%RH. This study clearly indicates that addition of chemical stabiliser compromises the hygroscopic behaviour of the material. In another study, Oudhof et al., (2015) determined the moisture buffering value of straw-clay mixture which is a type of earthen material usually prepared as a mixture of unprocessed earth, straw and water. Based on the Rode et al., (2005) categorisation, the moisture buffering values of different earthen materials as reported in these studies and others is presented in Figure 2.12.

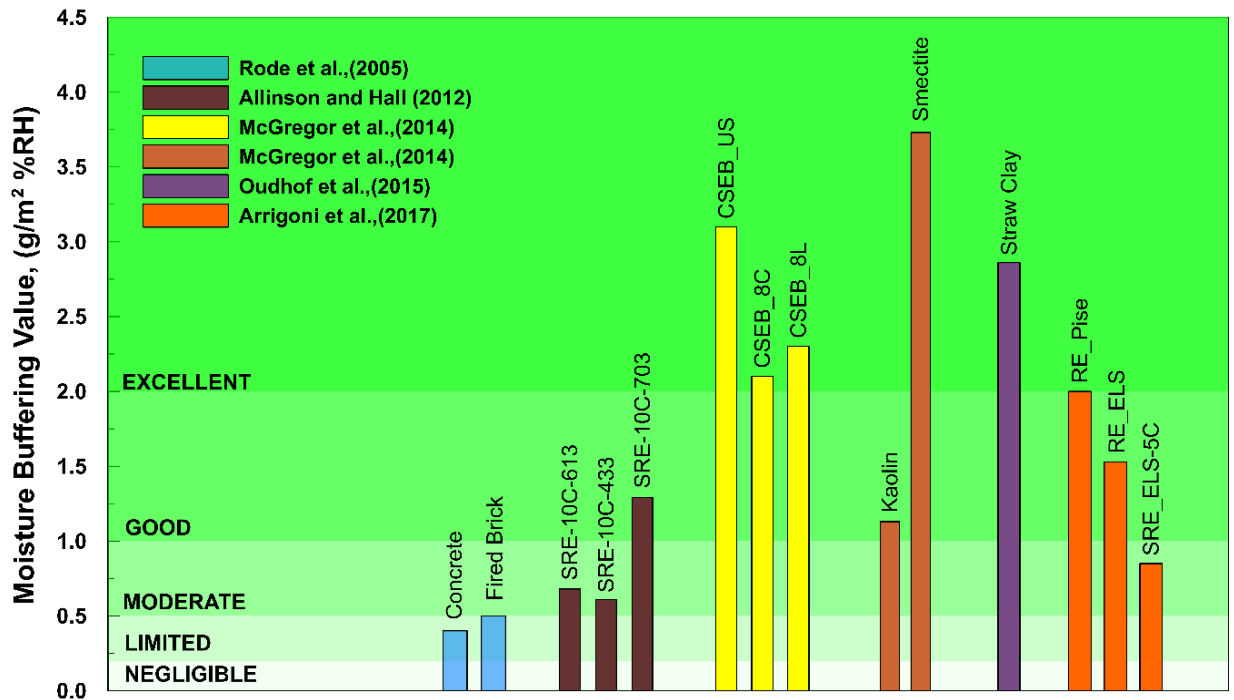

Figure 2.12 Moisture buffering values of different earthen materials as per Rode et al., (2005) categorisation.

#### 2.2.4.4. Recyclability potential of earthen material

From the Figure 2.13, it can be observed that recycling is the last step in completing the life cycle of earthen material. Modern earthen construction materials which were primarily developed as a low-cost walling unit have also got the perception that these materials can be recycled (Treloar et al., 2001). However, unlike unstabilised earthen materials which need less energy to recycle, modern earthen materials which rely on chemical stabilisation for good durability hinders the recycling process (Gallipoli et al., 2017). Cement stabilised earthen materials need high energy intensive process to completely recycled which is usually uneconomically. Hence, usually at the end of their life, stabilised earthen materials are downcycled through energy-intensive processes or easily dumped in a landfill (Schroeder, 2016). Disposal leads to accumulation of construction waste which is a significant contributor to overall global waste. This situation prompts one to explore ways to recycle these materials or to look for alternative stabilisers which can make the earthen material both durable and recyclable.

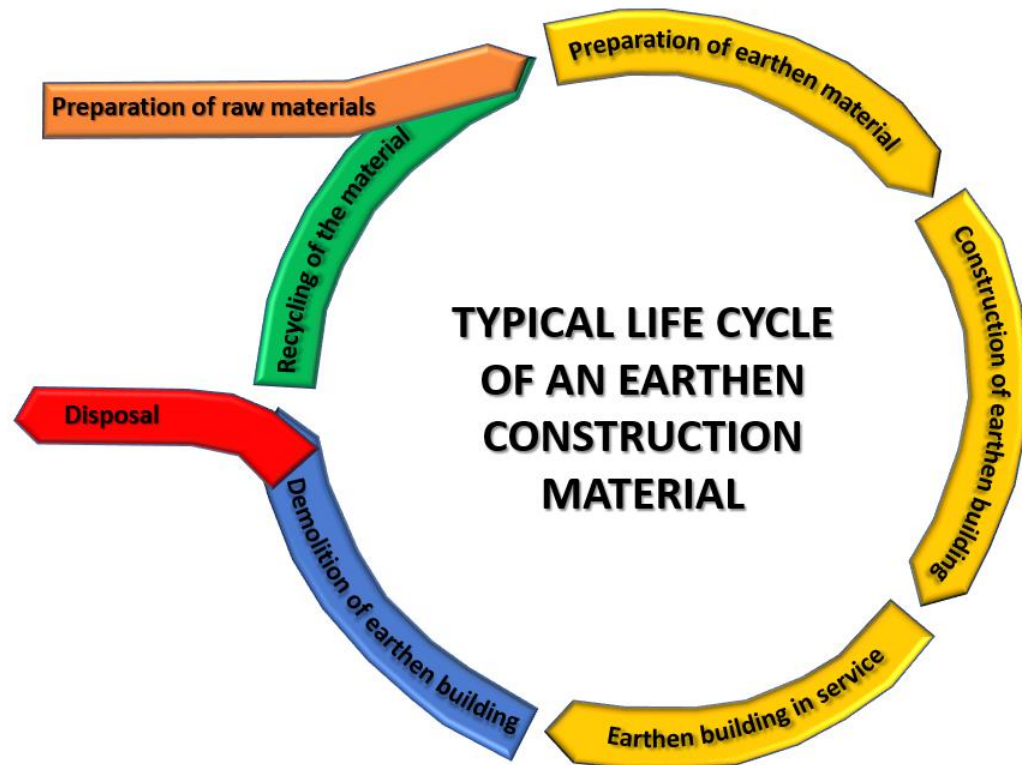

Figure 2.13 presents a typical life cycle of earthen construction material

## 2.3 Role of unsaturated soil mechanics in earthen materials

Earthen materials are compacted soil-mixtures which are primarily in an “unsaturated” condition in their lifetime. Therefore the behaviour of earthen construction materials can be understood by considering them in terms of unsaturated soil mechanics (Jaquin et al., 2009). This section presents the basic principles associated with unsaturated soil mechanics and related research studies in earthen materials.

### 2.3.1 Phase relationships

Soil is a three-phase material consisting of soil solids, water and air. Soil components such as gravel, sand, silt and clay constitute the soil solids which form the skeleton of a soil element. Air and water occupy the void space between the soil particles. A soil element is considered to be “saturated” if water fills up the voids, and when only air occupies the voids it is considered to be in “dry” state. In between these two extremities, where both air and water occupy voids the soil element is considered to be “unsaturated”. A typical illustration of these three states is presented in Figure 2.14.

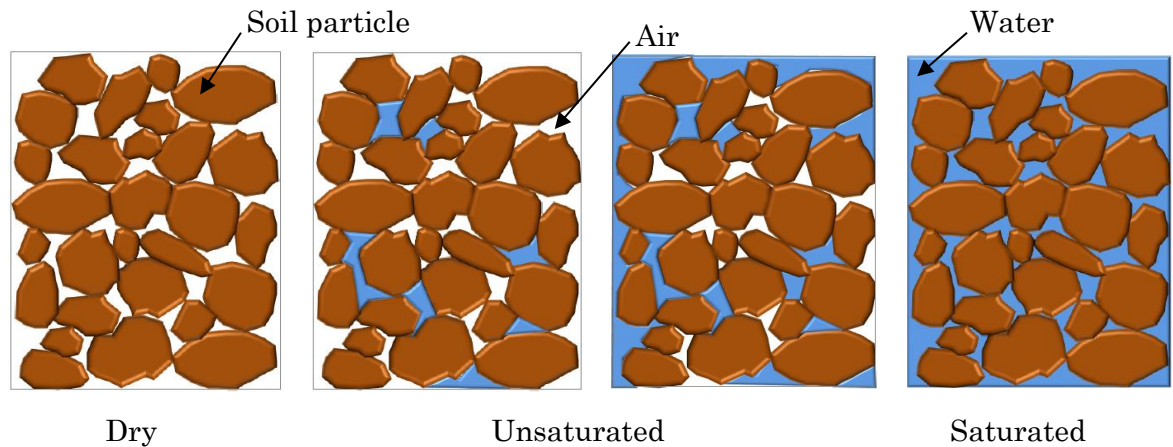

Figure 2.14 Different states of soil element

Phase relationships describe the soil skeleton and voids within a soil element. A selection relationship is given below.

1. The *void ratio* ( $e$ ), is the ratio of volume of voids present in the soil ( $V_v$ ), to the volume of solid particles ( $V_s$ ):

$$e = \frac{V_v}{V_s} \quad (2.2)$$

2. *Porosity* ( $n$ ), is the ratio of volume of voids to the total volume ( $V$ ), where  $V = V_v + V_s$

$$n = \frac{V_v}{V} = \frac{e}{1 + e} \quad (2.3)$$

3. The *degree of saturation* ( $S_r$ ). For a fully saturated soil, the degree of saturation is one, while for dry soil it is zero. Degree of saturation is expressed as the ratio of volume of water ( $V_w$ ) to the volume of voids ( $V_v$ ):

$$S_r = \frac{V_w}{V_v} \quad (2.4)$$

### 2.3.2 Strength of soils

Strength of the soil is the resistance to mass deformation developed from a combination of interparticle friction and adhesion and is reduced by presence of pore pressure. The resistance to deformation is shear strength of the soil unlike compressive or tensile strength of other engineering materials. The soil strength is measured in terms of two parameters: *cohesion* and *angle of internal friction*. Cohesion is the interparticle attraction, while angle of internal friction determines resistance to interparticle slip. The strength of the soil in terms of total stresses is expressed as

$$\tau = c + \sigma \tan \phi \quad (2.5)$$

While in terms of effective stress,

$$\tau' = c' + \sigma' \tan \phi' \quad (2.6)$$

where,

$\tau$  and  $\tau'$  is shear strength under total and effective stress conditions respectively  
 $c$  and  $c'$  is cohesion under total and effective stress conditions respectively,  
 $\phi$  and  $\phi'$  is angle of internal friction under total and effective stress conditions respectively,  
 $\sigma$  and  $\sigma'$  is normal stress under total and effective stress conditions respectively. In effective stress conditions,  $\sigma' = \sigma - \mu$ , where  $\mu$  is pore water pressure

### 2.3.3 Suction in unsaturated soils

Soil suction is defined as the energy required to extract unit volume of pore water, in other words, it is the potential energy of the pore water in an unsaturated soil (Lu and Likos, 2004). In other words, suction is the difference between pore air pressure and pore water pressure, i.e.  $s = u_a - u_w$ . In terms of stress variables, as soil suction increases as the negative pore pressure increases, which in turn increases the effective stress of the soil and thus the shear strength. However, as additional stress parameter which aids in the bonding of particles, suction is required to be considered as an independent stress variable to characterise unsaturated soil (Alonso et al., 1991; Gallipoli et al., 2003; Tarantino, 2007). Major components of suction are *matric suction* ( $\Psi_m$ ) and *osmotic suction* ( $\Psi_o$ ). The sum of these two components is referred to as *total soil suction* ( $\Psi$ ).

#### 2.3.3.1. Matric suction

Suction arising from the combined effects of capillarity of the pore water in soil and short-range adsorption of water on the particle surface is termed as *Matric suction*,  $\Psi_m$ . It is expressed as follows

$$\Psi_m = C(\kappa) + A(t) \quad (2.5)$$

where  $C$  is the capillary component described in its simplest form as a function of the water-air curvature  $\kappa$ , and  $A$  is the adsorptive component which is a function of the film thickness  $t$  (Philip, 1977).

The development of menisci and liquid bridges between soil particles due to the surface tension and interface curvature results in a difference between water and air pressure. This differential pressure leads to inter-particle forces stabilising the soil particles. This inter-particle forces contribution to the matric suction can be described by the capillary component  $C(\kappa)$  (Tuller and Or, 2005; Gens, 2010). In addition to capillarity, soils exhibit adsorption, which

leads to hydration envelopes over the particle surfaces. The adsorption of water on soil particles primarily occurs through electrostatic and van der Waals forces within the regions of the soil-water interface. The electrostatic forces arise due to the net negative charge on the clay surface, and the quantum of these forces depends on the clay mineralogy and net surface area of the clay. Van der Waals forces arise from the atomic interactions occurring between the surface of the soil particle and water molecules (Lu and Likos, 2004). In a given soil, quantification of these two components of matric suction is very difficult and also their effects on mechanical behaviour of soil cannot be considered to be equivalent (Baker and Frydman, 2009). At a high degree of saturation, the pore water in the soil matrix exists as a funicular (continuous) regime, and the capillary component will dominate, however, at relatively lower degrees of saturation, the pore water exists as a pendular (discontinuous) regime and the adsorptive component of suction will be prominent (Lu and Likos, 2004).

### 2.3.3.2. Osmotic suction

Osmotic suction arises due to the dissolved solutes in the pore water. Dissolved solutes may occur due to the introduction of salts into the pore water, either by externally induced solutes (e.g. natural leaching process) or due to naturally occurring solutes adsorbed by the soil mineral surfaces (e.g. exchangeable cations adsorbed by clay) (Lu and Likos, 2004). The introduction of these salts decreases the chemical potential of pore water resulting in difference of pressure between pore water and free water. This differential pressure is termed the *Osmotic suction*,  $\Psi_o$  (Lu and Likos, 2004).

### 2.3.3.3. Total suction

Based on the above discussion, it can be understood that the suctions developed in unsaturated soils are due to combination of matric and osmotic suctions. The algebraic sum of these suctions is usually termed the *Total suction*,  $\Psi$  (Lu and Likos, 2004; Gens, 2010). Total suction can be written as follows

$$\Psi = \Psi_m + \Psi_o = C(\kappa) + A(t) + \Psi_o \quad (2.6)$$

### 2.3.4 Soil-water retention curve

In unsaturated soil mechanics, soil suction and gravimetric water content are the two most important state variables. The functional relationship between these two variables is the *soil water characteristic curve* (SWCC). The use of the word '*characteristic*' would suggest that the soil has a unique relationship between suction and water content, however, in reality, the relationship between these two variables depends on the hydraulic and stress history of the soil (Lu and Likos, 2004). Nuth and Laloui (2008) suggested that it is therefore more appropriate to use the word '*retention*' rather than '*characteristic*' to express the relationship between soil suction and water for a given condition. Since then subsequent research studies now refer to

this functional relationship as the *soil water retention curve* (SWRC). Figure 2.15 presents a typical soil water retention curve presenting its prominent features.

When subjected to drying, a saturated soil starts to follow a *primary drying curve* on a SWRC. The largest pores start to desaturate first, and at this stage, air starts to enter the soil. This transition stage where air starts to enter the soil is known as the *Air Entry Value (AEV)*. Beyond this point, the water content tends to reduce sharply as finer pores start to desaturate. At a value of suction known as the *Residual Suction* (corresponding to residual water content), the curve may flatten indicating small changes of water resulting from higher variations of suction. In this residual zone, the water is primarily held as adsorbed water on clay particles rather than capillary water (McQueen and Miller, 1974). In order to achieve zero water content, a suction of 1GPa is required (Fredlund and Xing, 1994)

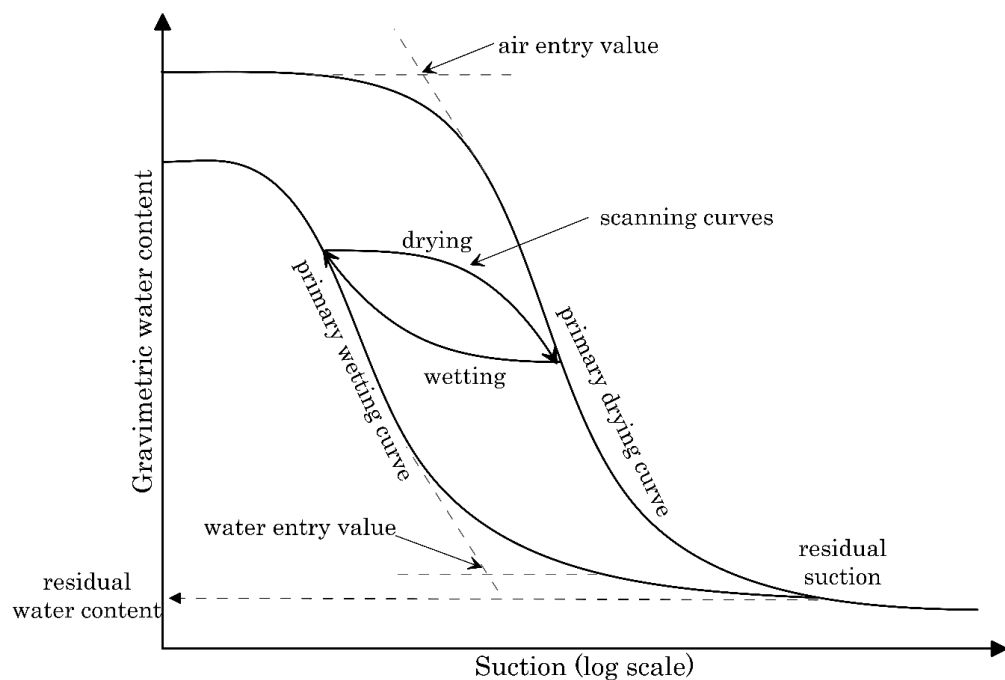

Figure 2.15 A typical soil water retention curve as presented by Toll et al., (2015)

On wetting the soil which is in the residual zone, the suction will decrease and follows the *primary wetting curve* path on the SWRC. At the *water entry value*, a significant increase in water content is noticed as many pores start to fill with water (Toll et al., 2015). The wetting continues until the soil becomes completely saturated; however, the final water content may be lower than the initial saturated water content. The primary drying and wetting curves present a hysteretic envelope within which the soil can exist (Toll et al., 2015). Within these primary curves, a soil may be wetted partway during the drying process; at this stage, the soil may follow a flatter *scanning curve* until it reaches the primary wetting curve. Similarly, if wetting is halted partway, the soil will follow a *scanning curve*, until the primary curve is reached. Within this scanning region, the behaviour is thought to be reversible while water retention along the

primary curves is irreversible (Tarantino, 2009). The hysteresis effect of drying and wetting the soil shows that the suction required to dry a wet soil to given water content is not the same as the suction required to wet a dry soil to achieve the same water content (Nishimura and Fredlund, 2002; Rojas and Rojas, 2005).

The primary factors which influence the shape of SWRC are soil type and its gradation, pore size distribution, density and clay mineralogy (H. Yang et al., 2004; Lu and Likos, 2004). Being inert and having a less specific surface area, the adsorption component of suction for sands is relatively low. Over the unsaturated water content range, capillarity is the predominant contributor to the suction component for sands (Lu and Likos, 2004). Compared to clay, the air entry value for sand is lower, and the pore size distribution controls the overall shape and slope of the SWRC (Hillel, 1998; H. Yang et al., 2004; Lu and Likos, 2004). Sands having lower porosities such as uniformly graded or dense sands have steeper slopes, lesser hysteresis, higher air entry value and residual suction in their SWRCs (H. Yang et al., 2004). With higher specific surface area and charged surfaces, the adsorption component of the suction dominates in clays. The air entry value and residual suction of the clays are relatively higher than sand and in addition, the shape of the SWRC for clays is affected by the clay mineralogy. As seen from Figure 2.16, high plasticity clays such as smectite may sustain extremely high suctions over a wide range of water contents, while low plasticity clay such as kaolin may adsorb less water in the high suction regime (Likos, 2000).

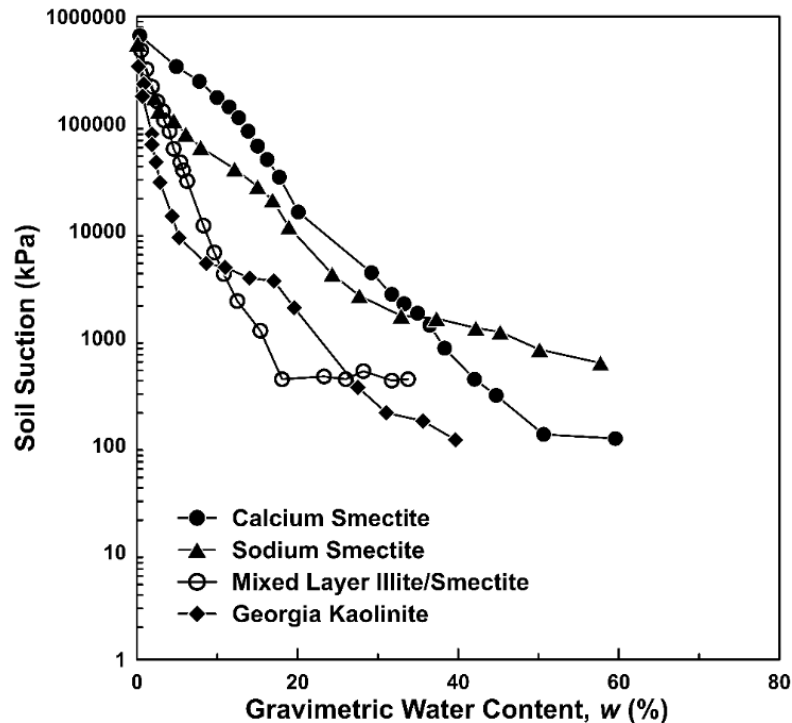

Figure 2.16 Effect of clay mineralogy on soil water retention in the high suction regime (Likos, 2000)

### 2.3.5 Role of soil suction in earthen construction materials

Several researchers have tried to understand the behaviour of earthen materials through unsaturated soil mechanics principles (Jaquin et al., 2009; Nowamooz and Chazallon, 2011; Beckett and Augarde, 2012; Bui et al., 2014; Al Aqtash and Bandini, 2015; Gerard et al., 2015; Beckett et al., 2017). A selection of the essential works undertaken on this subject is herein discussed.

In order to understand the influence of suction on the strength of drying earthen construction material, a study was undertaken by Jaquin et al.,(2009) in which coarse aggregate, sand and clay/silt (0.25:0.60:0.15) were blended and sieved through a 14 mm sieve to prepare a rammed earth mixture. Compaction tests were performed on this rammed earth mixture to obtain the optimum water content which was nearest to saturation. This water content (i.e. 12.0%) was used to prepare cylindrical samples of the rammed earth mixture. Cylindrical samples were compacted in five layers using 15 blows of a 4.5 kg hammer. Dry densities between 2017 and 2061 Mg/m<sup>3</sup> were achieved using the same compactive effort each time. These cylindrical samples were subjected to air drying, and once a target water content was achieved, samples were sheared using a triaxial rig. During shearing, a high-capacity tensiometer was employed for continuous measurement of suction. The results indicate that there is a clear relationship between initial water content and both suction and strength. Under constant gravimetric water content, samples with initially low suctions showed an increase in suction during shearing, whereas samples with high suction showed the opposite indicating the existence of a unique water content – suction relationship at the critical state (Figure 2.17). The study further suggests that stiffness of the material is suction dependant.

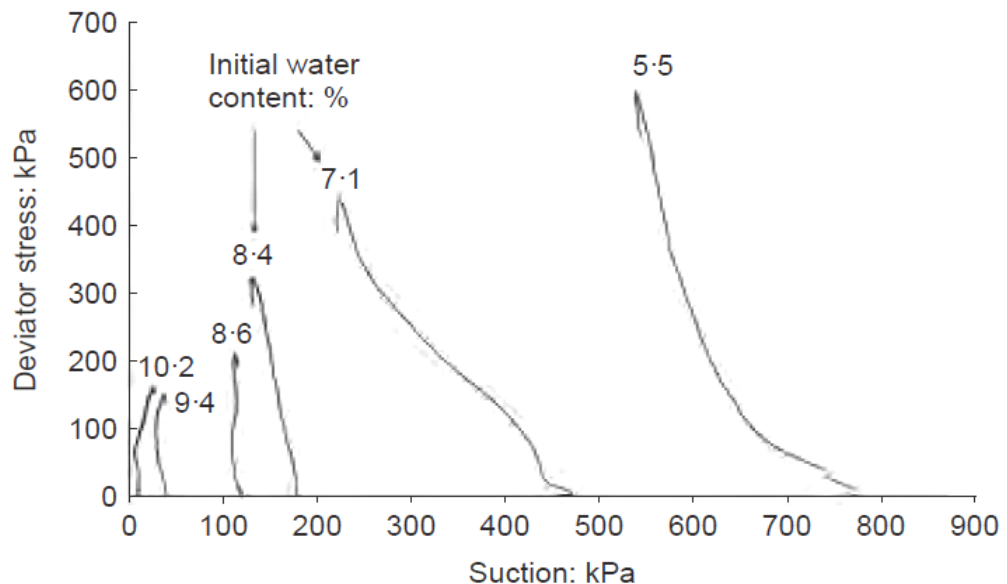

Figure 2.17 Plot showing the variation of deviator stress and suction for different initial water contents, Reproduced from Jaquin et al., (2009).

Bui et al., (2014) undertook a research study to understand the influence of water content on the mechanical characteristics of rammed earth materials prepared with different soils and with a greater range of water contents. Three soil mixtures were considered in this study, i.e. sandy soil, clayey soil and clayey soil stabilised with 2% natural hydraulic lime. UCS test specimens of 300mm length for all soil mixtures were prepared with an initial water content of 11.0% and then the samples were left for air drying to achieve desired water contents. Water contents varying from 11.0% (wet) to 2% (dry) were considered. At desired water contents, samples were placed inside an airtight cover for seven days to ensure the circulation of moisture within the sample. Compressive strength, secant modulus and Poisson's ratio were obtained from the compressive tests. Filter paper method tests (Pierre Delage, 2002) were used to measure suction at different water contents. Variations of suction with mechanical properties were determined. The results confirmed that suction is an important factor contributing to the mechanical behaviour of rammed earth, and varied with water content (Figure 2.18).

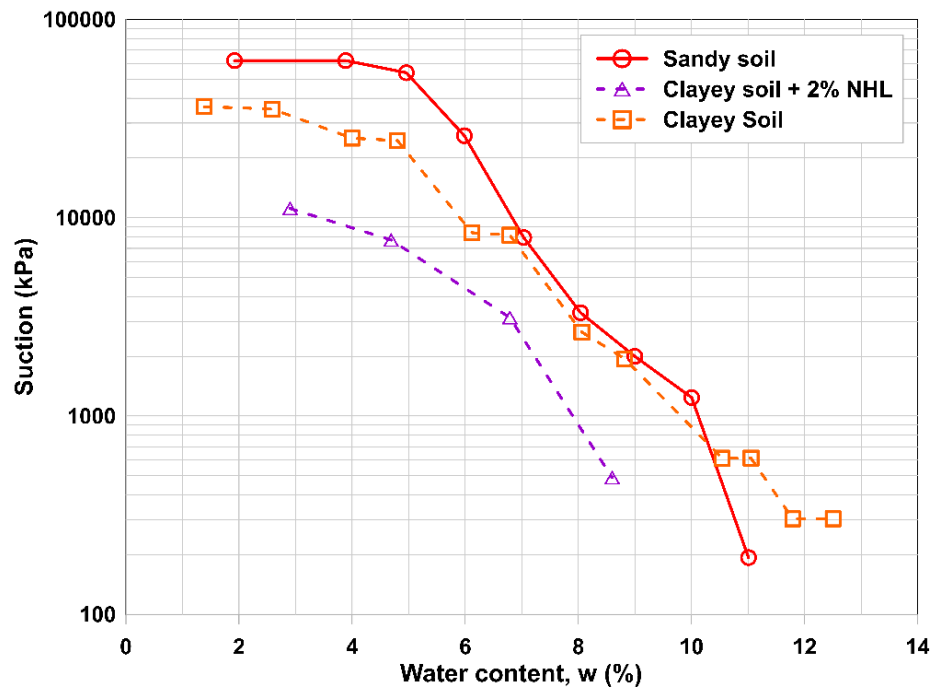

Figure 2.18 Variation of suction with water content (Bui et al., 2014)

Beckett and Augarde (2012) studied the effect of relative humidity and temperature on the strength of rammed earth. Two soil mixtures referred by their relative mix proportions (Sand: Gravel: Clay) 5-1-4 and 7-1-2 were used in their study. 100mm cube specimens for both the mixes were prepared by compacting in three layers to achieve respective optimum density. A screed of mix material passing through 1.18mm was applied on the uppermost surface of the sample to ensure a smooth surface for compressive testing. Samples were left to dry naturally until they reached a constant mass. They were then transferred to the environmental chamber to be held at a given temperature and humidity for seven days to ensure equilibration. A range of temperature and relative humidity values (15, 20, 30 and 40 °C and 30, 50, 70 and 90%) were

selected to replicate different climatic conditions. After equilibration, the samples were removed from the chamber and were tested for unconfined compression. Figure 2.19 shows the UCS results for both the soil mixes. It was reported that the UCS's for both the mixes were significantly affected by humidity and temperature. Results suggested that there was only a slight variation in wetting and drying suction due to very low water contents. For a given applied suction, soil mix 5-1-4 had higher water content, and relatively higher adsorbed water contents than soil mix 7-1-2 due to the presence of a higher clay content. With respect to UCS, at a given suction 7-1-2 achieved higher strength than 5-1-4 due to the former's lower relative adsorbed water content. It is clear from this study that the strength of these unsaturated earthen construction materials is significantly affected by changes in temperature, relative humidity and clay content.

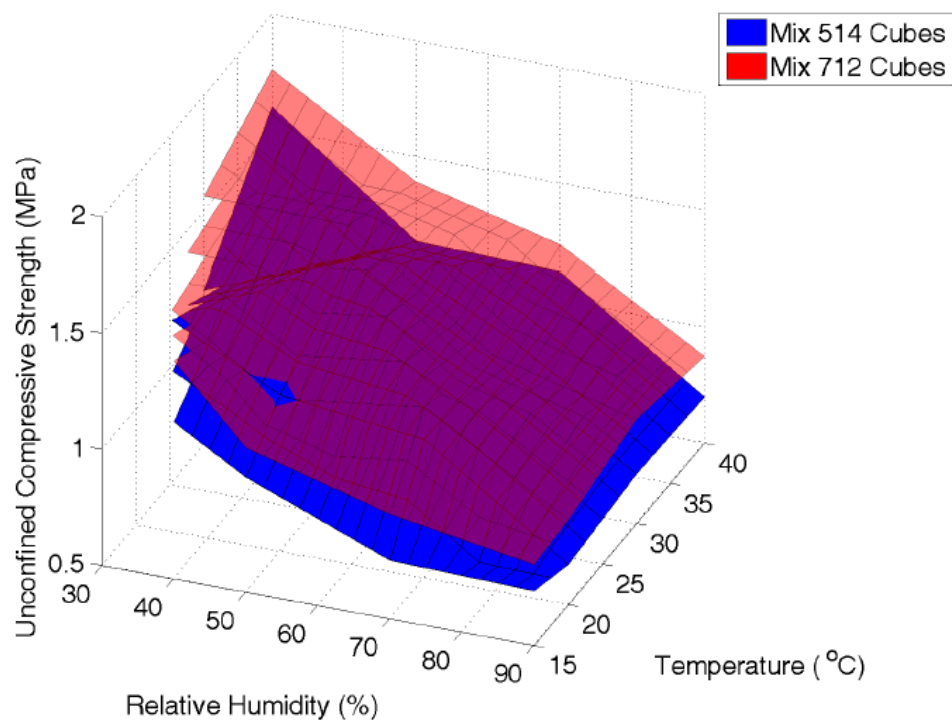

Figure 2.19 UCS of 5-1-4 and 7-1-2 mixes against humidity and temperature (Beckett and Augarde, 2012)

Champiré et al., (2016) investigated the role of clay mineralogy on the mechanical behaviour of unstabilised earthen materials under different relative humidity levels. For this purpose, soils denoted as STR and CRA which had varying clay mineralogy were collected from an existing rammed earth house in South-East of France. The physical properties of these earthen materials, such as particle size distribution, Atterberg limits, clay activity and dominant clay minerals of the earthen materials were determined. These earthen materials had similar soil gradation to each other consisting of 15% clay, 20% silt, 65% sand and similar dry density, but varying clay activity. Cylindrical samples with a diameter of 64.4mm and length of

140mm were prepared. Compressive strengths of these cylinders were determined at a constant temperature of  $24 \pm 2^\circ\text{C}$  and varying relative humidity levels (25%, 75% and 95%). It was noted that these materials exhibited different mechanical behaviour under similar ambient conditions. The sample with higher clay activity (i.e., CRA) was less rigid and less resistant than the other samples. Differing mechanical behaviour between these earthen materials at similar ambient conditions can be related to the clay mineralogy which contributes differently to the adsorption component of suction.

Beckett et al., (2017) predicted rammed earth strength based on extended Mohr-Coulomb (EMC) framework. Unconfined compressive strength and indirect tensile strength (ITS) were determined for cylindrical specimens prepared for mixtures used in their previous work (Beckett and Augarde, 2012). For these strengths at residual suction, failure envelopes based on an 'extended' Mohr-Coulomb criterion were constructed and methods to predict strengths were derived. Excellent agreement was found between the measured and predicted strengths of the earthen materials. A simplified experimental procedure for field practitioners was also recommended for predicting strengths based on the EMC framework. Using this procedure an existing rammed earth facility predicted strengths of a compacted Californian sandy loam. Figure 2.20 presents the planar EMC failure envelope for the Californian sandy loam.

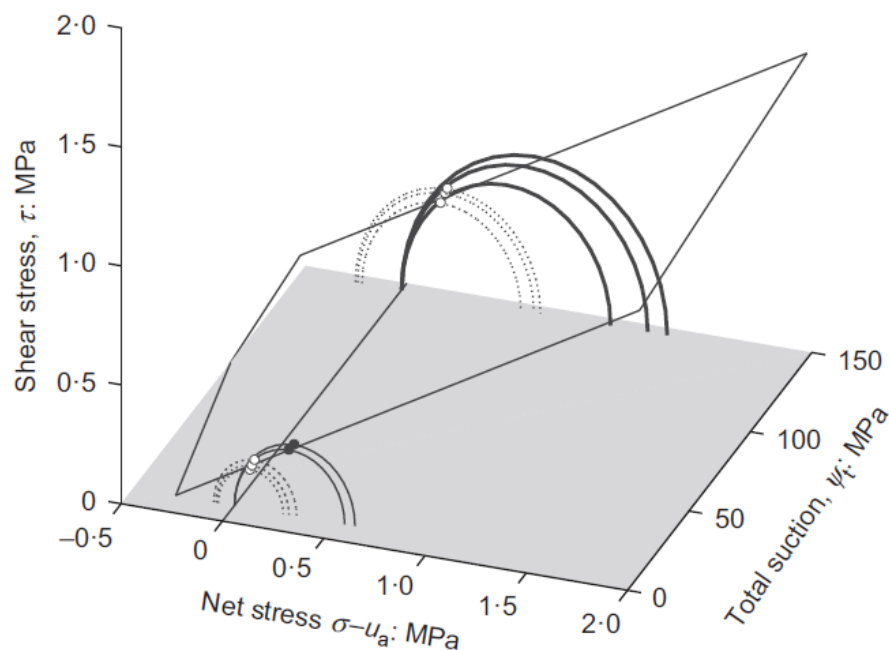

Figure 2.20 Planar EMC failure envelope for California sandy loam used for rammed earth construction (Beckett et al., 2017)

### 2.4 Bio-stabilisation techniques

In most historical earthen structures, the mechanical properties of the soil were improved through either mechanical tamping or with the additions of bio-material in the form of egg-whites or proteins (Plank, 2004; F. Yang et al., 2010). Now industrial stabilisers like cement have replaced these bio-stabilisers for improved strength and durability. The current state of practice of using cement and lime for improving engineering properties of earthen materials have been criticised for a lack of sustainability (Lax, 2010; Maskell et al., 2014). This has prompted research effort to find suitable alternatives for energy intensive and CO<sub>2</sub> producing stabilisers (Chang et al., 2016). Bio-stabilisation methods used historically may have the potential to replace cement and provide sustainable soil stabilisation.

#### 2.4.1 Bio-stabilisation of soils

The use of biological process or products to improve soil properties is termed “bio-stabilisation” of soils. Bio-stabilisation is not a new process known to humanity. The Romans used bio-stabilisers like proteins as set retarders for gypsum used in building construction (Plank, 2005), while the Chinese used sticky rice mortar as a construction binder for the Great Wall of China (F. Yang et al., 2010). Today, bio-stabilisation techniques have been proposed as a potential alternative to chemical stabilisers and are being actively investigated in different geotechnical engineering applications.

Based on the requirements, bio-stabilisation methods can be classified broadly under eight categories (Stabnikov et al., 2015):

1. *Bioaggregation of soil*: to increase the effective size of the soil particles to reduce soil erosion and dust emission.
2. *Biocrusting*: formation of a crust on the soil surface to resist wind and water erosions and to reduce dust emission and water erosion.
3. *Biocoating*: formation of a layer on a solid surface so that the colonization or aesthetics, or corrosion protection of the surface is improved.
4. *Bioclogging*: filling in the pores of the soil or rock fissures in order to reduce the permeability of the material.
5. *Biocementation*: binding of soil particles in order to improve soil strength significantly.
6. *Bio desaturation*: to produce biogas bubbles in-situ to reduce saturation and liquefaction potential of soil
7. *Bioencapsulation*: to increase the strength by encapsulating soil particles like soft clay, loose sand, quick sand and muck soil
8. *Bioremediation*: biodegradation of the soil pollutants in contaminated soils.

In earthen construction materials, as a potential replacement to chemical stabilisers, the bio-stabilisation method of interest should be that which binds the soil particles to increase shear strength, i.e. *Biocementation*. Within *biocementation*, microbial-induced calcite precipitation (MICP) and biopolymer stabilisation techniques have been considered as potential alternatives to traditional stabilisers (Ivanov and Stabnikov, 2016; Pacheco-Torgal et al., 2016). MICP employs micro-organisms to precipitate calcium carbonate into the soil voids and to provide particle bonding (Fujita et al., 2000). While MICP has been found to be applicable to soil remediation and CO<sub>2</sub> sequestration (Renforth et al., 2009), it has several shortcomings with respect to field implementation for fine-grained soils, transportation, cultivation and possible toxic residues (Rong et al., 2011; Pacheco-Torgal and Labrincha, 2013; Chang et al., 2016; Pacheco-Torgal et al., 2016). Other the other hand, biopolymer stabilisation is another biocementation process which has been used in the recent past for soil stabilisation. Unlike MICP, biopolymers have a relatively simple application procedure and provide enhanced soil stabilisation for different soil types (Chang et al., 2016). In addition, there is an excellent diversity of biopolymers available, and the market share of biopolymers is expected to increase due to growing interest in using biodegradable building materials (Babu et al., 2010).

### 2.4.2 Biopolymer soil stabilisation

Biopolymers are naturally occurring polymers synthesised through biological processes. These biopolymers are polysaccharides composed of a large network of bonded monosaccharide units. These monosaccharide units maybe the simplest form of carbohydrates, which have carbon atoms bonded with hydroxyl groups (e.g. glucose, fructose or galactose). When mixed in water, the hydroxyl groups of each monosaccharide unit in the polysaccharide readily interact with water to form "*hydrogels*". Figure 2.21 presents an example of how the monosaccharide units link with each other to form a long chain polymer. This long chain of monosaccharide is the backbone, while the outer hydroxyl groups are cross-links of the biopolymer.

These "*hydrogels*" can be defined as chemically or physically as cross-linked polymers having a hydrophilic structure which allows them to absorb water into their three-dimensional porous structure and swell without dissolving (Brax et al., 2017). Their ability to absorb water arises from hydrophilic functional groups attached to the polymer backbone, while their resistance to dissolution comes from the cross-links between network chains (Gerlach and Arndt, 2009). When mixed with soil and water, these hydrogels form a complex structure connecting soil particles. In the case of granular material, these hydrogels coat themselves to the surface of soil particles and bind them together to provide the stabilisation effect (Chang, Prasadhi et al., 2015). While in clays, the stabilisation is primarily achieved through either hydrogen and/or ionic bonding with clay particles depending on the intrinsic properties of the biopolymers chosen (Chen et al., 2013; Chang et al., 2015). Figure 2.22 shows a typical interaction of biopolymer with granular media as presented by Qureshi et al., (2014).

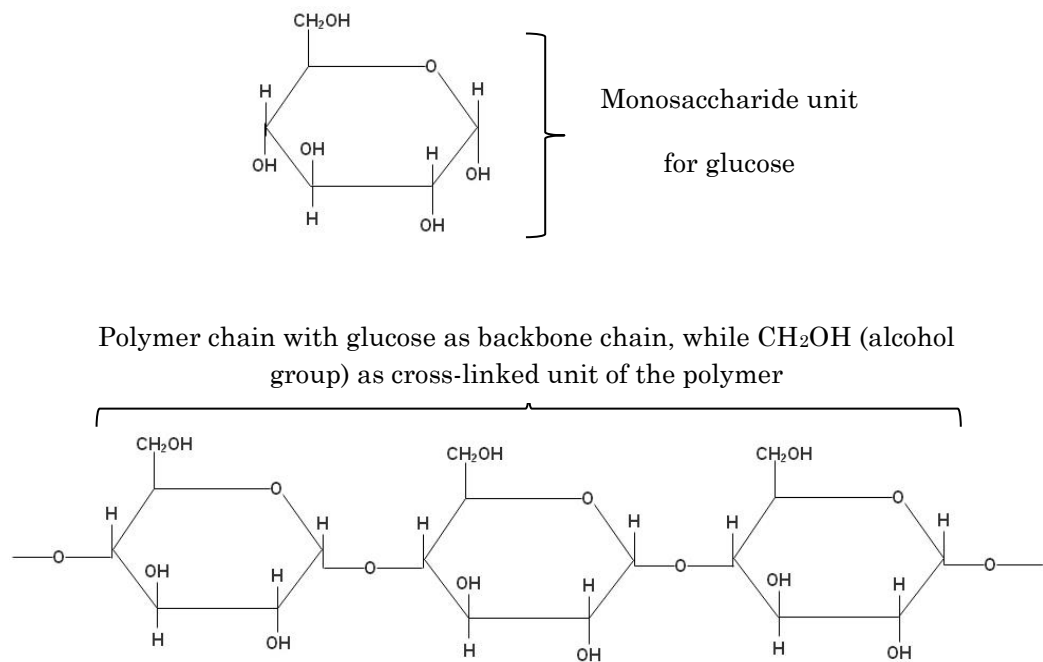

Figure 2.21 An example of how the monosaccharide units combine to form a biopolymer

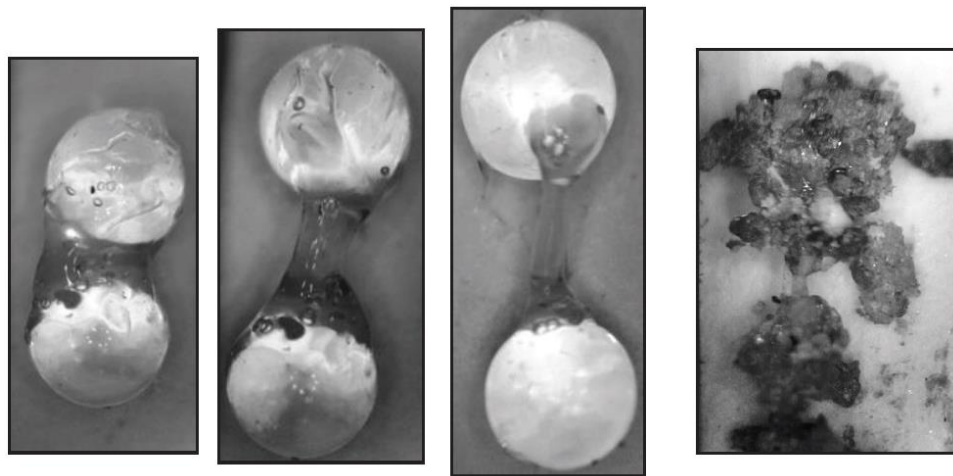

Figure 2.22 typical interaction of biopolymer with granular media as presented by Qureshi et al., (2014)

### 2.4.3 Biopolymer stabilisation in geotechnical engineering

In geotechnical engineering applications, biopolymers were initially used to reduce soil permeability and have consequently found application in seepage barriers. It was reported that introduction of biopolymers in small quantities ensured reduction of hydraulic conductivity of the soil by three to four orders of magnitude indicating the pore plugging effect (Bouazza et al., 2009; Aminpour and O'Kelly, 2015). More recently, researchers have used different biopolymers

to improve the engineering properties of particular soils (e.g. sand or clay) and attempted to understand different aspects of biopolymer stabilisation such as suitable curing conditions, its suitability for different soil types, and effects on physical, mechanical, hydraulic and durability properties of the soil (Cabalar and Canakci, 2011; Khatami and O’Kelly, 2013; Chang, Im et al., 2015; Ayeldeen et al., 2016; Latifi et al., 2016; Qureshi et al., 2017). Biopolymers such as xanthan gum and guar gum which have not only shown promising stabilising effects (Bouazza et al., 2009; Cabalar and Canakci, 2011; Chang, Im et al., 2015), but are also have better stability against pH and temperature variations (Chudzikowski, 1971; Katzbauer, 1998). With these credentials, guar gum and xanthan gum are chosen as potential biopolymers in this study hence, the focus of the literature review has been limited to these biopolymers.

### 2.4.3.1. Guar Gum

Guar gum is powdered endosperm of cluster bean (*Cyamopsis tetragonolobus*) which belongs to Leguminosae plant family (Chudzikowski, 1971; Mudgil et al., 2011). The process of extracting endosperm involves different stages and varies according to the quality and species of the plant. Detailed information on manufacturing process are reported by Mudgil et al.,(2011) and Thombare et al., (2016). The extracted endosperm undergoes purification and the efficiency of purification determines the quality of guar gum (Thombare et al., 2016). Based on the seed quality, amount of impurities present, viscosity potential and rate of hydration different grades of guar gum are manufactured which have different industrial applications (Chudzikowski, 1971; Thombare et al., 2016).

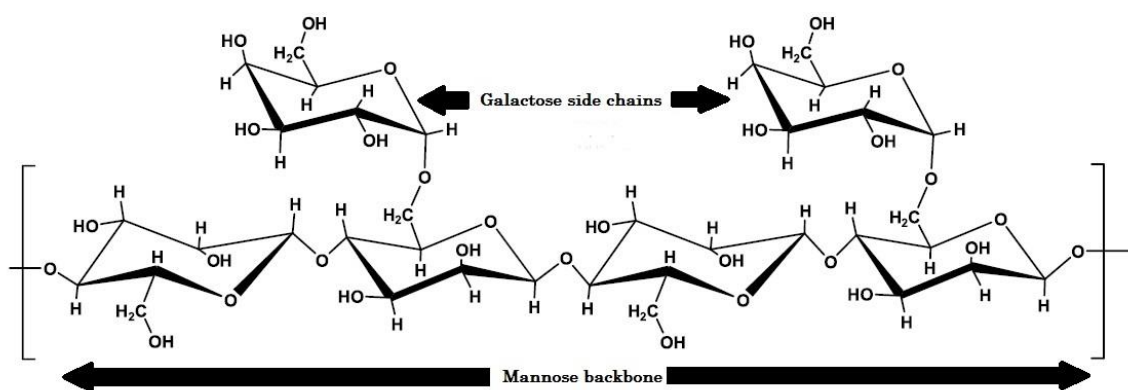

Figure 2.23. Typical chemical structure of guar gum.

Chemically, guar gum is a neutrally charged polysaccharide made of galactose and mannose groups (Figure 2.23). Mannose groups form the backbone of the guar gum, while galactose groups which are attached to the mannose groups are the side chains of the polymer. This rich hydroxyl polymer readily reacts with water through hydrogen bonding, significantly imparting the viscosity and thickens the solution. Apart from being thickener, guar gum

dissolves in cold water and has wide pH and thermal stability (Chudzikowski, 1971; Thombare et al., 2016). With these properties, guar gum has found applications in many industries.

### 2.4.3.2. Xanthan Gum

Xanthan gum was discovered in 1961 by the research laboratories of the US Department of Agriculture (Katzbauer, 1998). Xanthan gum is produced from plant-pathogenic bacterium *Xanthomonas campestris*. To produce xanthan gum, the bacterium is cultured in a well aerated and agitated fermenter. The medium consists of carbohydrate source, nitrogen source and nutrient salts which aid in fermentation process. After fermentation, the bacteria are removed by heating and xanthan gum is recovered through precipitation. The polymer is then dried, milled and packed. Factors such as carbohydrate source, fermentation process and heating temperature define the quality of xanthan gum. Detailed manufacturing process of xanthan gum is reported by Garcia-Ochoa et al.,(2000). Figure 2.24 illustrates typical chemical structure of xanthan gum. Chemically, xanthan gum is an anionic polymer whose backbone consisting repeated pentasaccharide units formed by two glucose units, two mannose units and glucuronic acid unit. Trisaccharide side chains contain glucuronic acid between two mannose units (Becker et al., 1998; Katzbauer, 1998; Garcia-Ochoa et al., 2000). Similar to guar gum, the hydroxyl groups of the group readily with water which significantly increases viscosity of the solution. Xanthan gum easily dissolves in cold water and has good stability against pH and temperature variations (Katzbauer, 1998). Another important property of xanthan gum is that they work in synergy with plant galactomannans as guar gum to increase viscosity (Garcia-Ochoa et al., 2000).

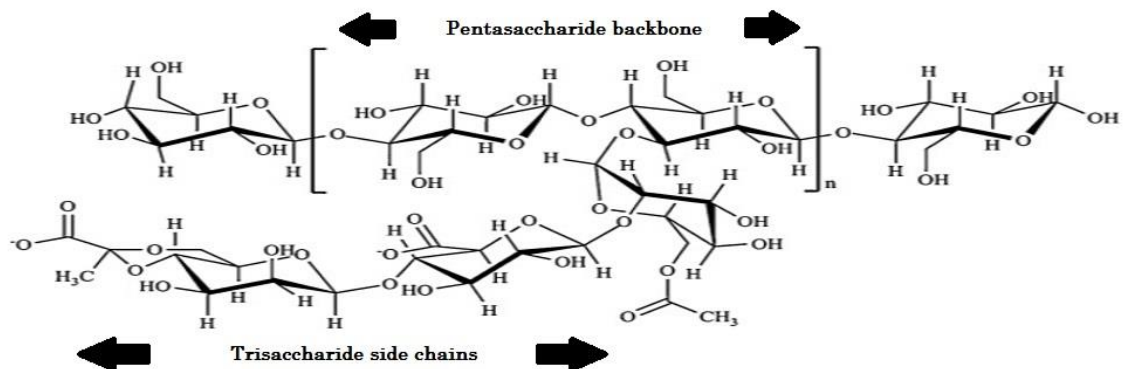

Figure 2.24. Typical chemical structure of xanthan gum.

### 2.4.3.3. Effect of biopolymer stabilisation on different soil properties

Cabalar and Canakci (2011) investigated the effect of xanthan gum on the strength of sand using direct shear tests. In their study, loose sand was mixed with xanthan gum solutions of 1.0, 3.0 and 5.0% by mass of the soil to form a homogeneous paste. This paste was then poured

into a mould to cure at room temperature for 7, 26 and 50 days. After these curing periods, the treated sand was tested in direct shear. It was reported that the samples with higher xanthan gum solutions of 3.0% and 5.0% had a higher angle of internal friction than those of untreated samples indicating improvement in soil strength due to the addition of xanthan gum. More importantly, it was noted that the improvement in strength was noticed within seven days of curing and the impact of curing time was not significant.

Chen et al., (2013) conducted a feasibility study to understand the stabilisation effect of guar gum and xanthan gum on mine tailings. The fall cone method was used to determine the liquid limit and undrained strength of sun-dried mine tailings mixed with xanthan gum and guar gum solutions. Microstructural imaging was undertaken using environmental scanning electron microscopy (ESEM). The study found that the addition of biopolymers increased both the liquid limit and the undrained strength of the treated mine tailings. Being a neutral polysaccharide, guar gum induced slight aggregation of the mine tailing particles with only hydrogen bonding. In the case of xanthan gum which is an anionic polysaccharide provided a higher degree of aggregation due to additional ionic bonding along with hydrogen bonding. Figure 2.25 presents the ESEM images of xanthan gum and guar gum treated mine tailings as presented by Chen et al., (2013). From the ESEM scans, it can be observed that guar gum form smaller soil agglomerations than xanthan gum, at the same time xanthan gum induces higher void spaces within the soil matrix.

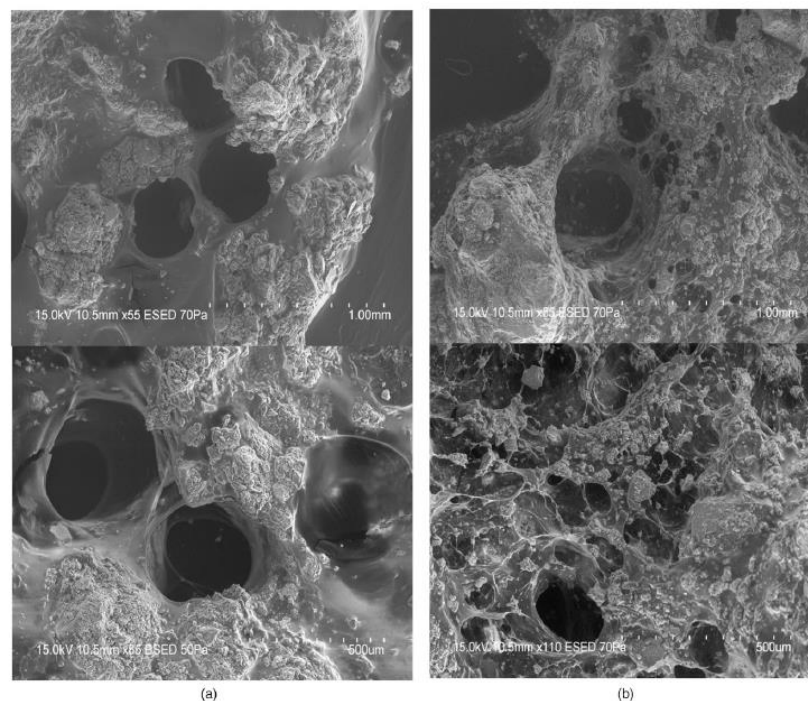

Figure 2.25. ESEM images of mine tailings treated with (a) xanthan gum (b) guar gum (Chen et al., 2013)

Chang et al.,(2015) describes a study of the strengthening effect of xanthan gum on different soil types namely sand, poorly graded sand, natural lean clay and kaolinitic clay. Soils were treated with 1% of xanthan gum and tested for compressive strength on 40mm cubes cured at 200°C for 28 days. It was reported that xanthan gum was more effective in improving the strength and stiffness of clays and well-graded soils. In order to determine an efficient mixing method, two methods were adopted: dry mixing the xanthan gum with soil before the addition of water and wet mixing in which the xanthan gum was premixed in water before its application to the soil. The compressive strength of the samples of dry mixing was found to be more effective than wet mixing indicating that the former was an appropriate method for practical applications (Figure 2.26). Scanning electron microscope (SEM) images were obtained at the end of 28 days for three of the samples, i.e. sand, clay and red yellow soil (Figure 2.27). It can be observed from Fig 2.27a, for sand, xanthan gum coated the grain surfaces and increased the interparticle contact area, while in clays xanthan gum strands directly linked the clay particles and these links are caused due to hydrogen bonding (Fig 2.27b and 2.27c). To understand the effect of biopolymer content, the soils were treated with different xanthan gum contents, i.e. 0.5, 1.0 and 1.5 % of dry soil mass and tested for unconfined compressive strength. It was reported that the strength increased with biopolymer content, however, at 1.5% content, the soil mixture was found to be less workable due to increased viscosity. These research findings give an insight into various aspects of bio-stabilisation of soils, i.e. soil composition, mixing techniques, biopolymer proportions and interactions.

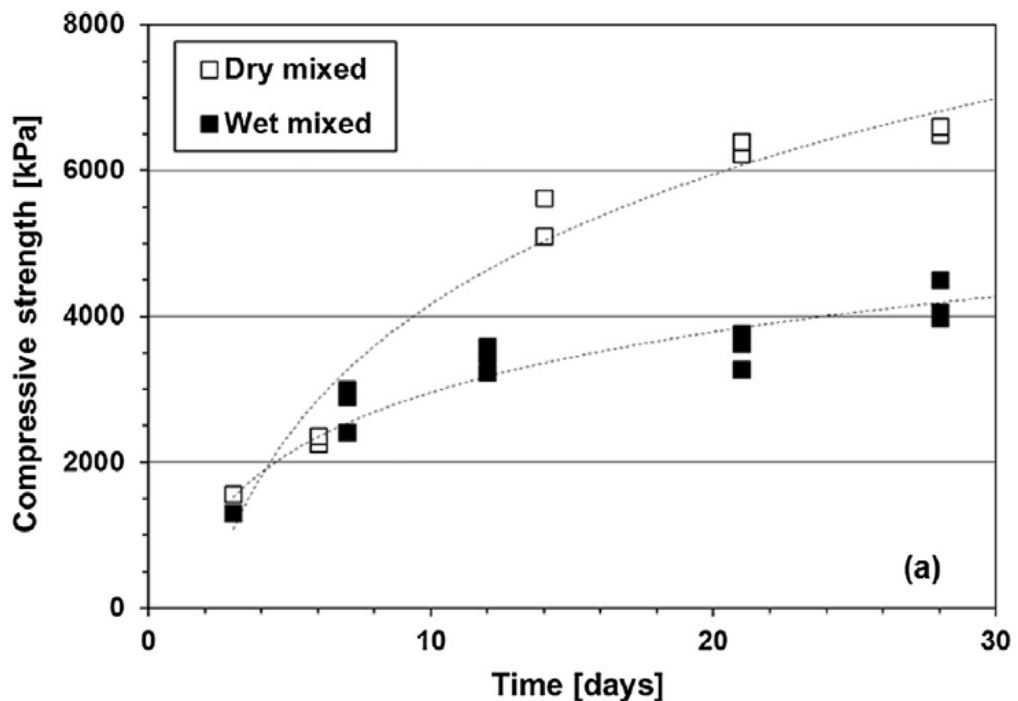

Figure 2.26. Comparison of compressive strength for dry and wet mixing methods (Chang et al., 2015)

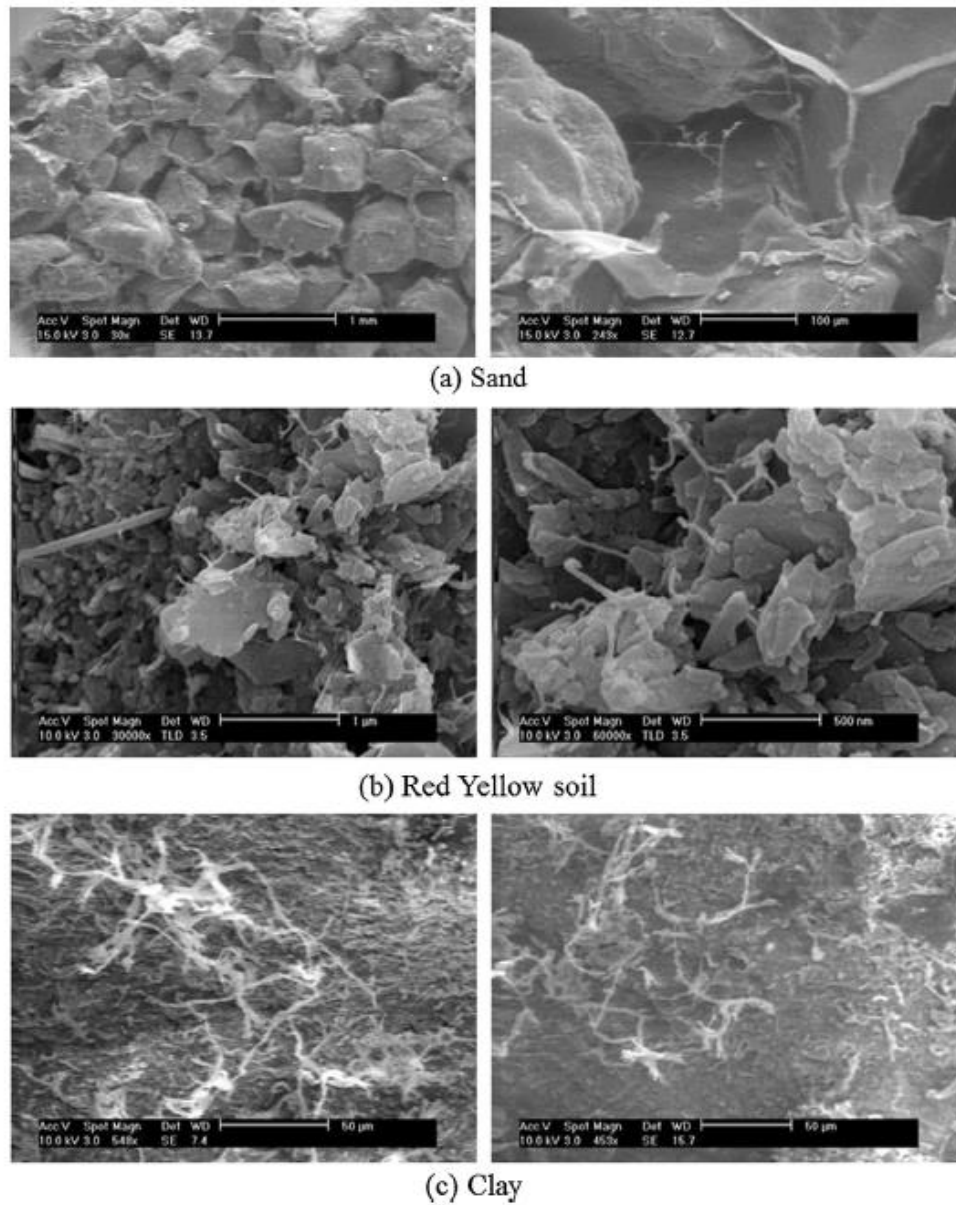

Figure 2.27. SEM Images of xanthan gum treated soils (Chang et al., 2015)

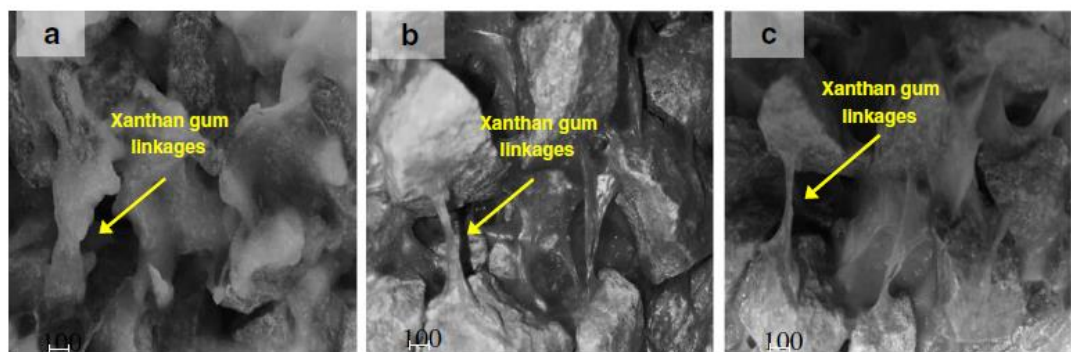

Figure 2.28. SEM Images of xanthan gum treated sand for different curing times (a) 1h, (b) 1 week and (c) 3 week (Ayeldeen et al., 2016)

Ayeldeen et al (2016) treated sand and silt with biopolymers ( xanthan gum, modified starch and guar gum) and then studied the effect of these biopolymers on compaction, strength and permeability characteristics. Biopolymer concentrations of 0.25, 0.5, 1.0 and 2.0 % of dry soil mass were considered in this study. The addition of biopolymers increased the strength of the soils with time, while the permeability decreased. It was reported that the optimum water content increased with increasing biopolymer content for both soils. However, the maximum dry density of the sand showed a steep increase for biopolymer contents from 0.25% - 1.0%, after which there was only marginal increase. In the case of silt, the behaviour was different: the maximum dry density decreased with increase of the biopolymer content. From these findings, it can be concluded that though the addition of biopolymer has improved strength and permeability properties of both soils, it had a different effect on compaction characteristics depending on the soil type. In addition, the study used SEM imaging to understand the effect of curing on the hydrogels formed. From Figure 2.28, it can be observed that at the early stages of biopolymer application, the hydrogels formed are in a thick gel state which transforms to a thinner glassy state with time. It was reported that the change of these hydrogels to glassy state is the reason for higher compressive strength with ageing.

Latifi et al., (2016) studied the effect of xanthan gum on two fine-grained clays namely, bentonite and kaolinite. The two soils were treated with 0.5, 1, 1.5, 2 and 2.5% of xanthan gum and tested for its unconfined compressive strength at 3, 7, 28 and 90 days. Based on these tests, it was concluded that 1.5% was the optimum stabiliser content for both soils. Direct shear tests and one-dimensional consolidation tests were performed for both the soils treated with the optimum stabiliser content at 7, 28 and 90 days. It was reported that there was a significant increase in cohesion for both soils with curing, while the increase in angle of internal friction was marginal. It was reported that the significant changes for the treated soils occur within 28 days of curing. Based on one-dimensional consolidation tests, it was concluded that the compressibility for both soils improved, i.e. specimen compressibility decreased with curing time. These changes were thought due to the formation of hydrogen bonds between the xanthan gum and clay particles which led to the formation of large, firm biopolymer-soil matrices (with flocculated structure) having lesser void space. In order to understand the stabilising effect on particle size distribution, laser diffraction was performed. Figure 2.29 presents the results of these tests for both the soils. Based on these results, it was concluded that the soil-biopolymer interactions lead to particle agglomerations and reduced overall external surface area of the particles.

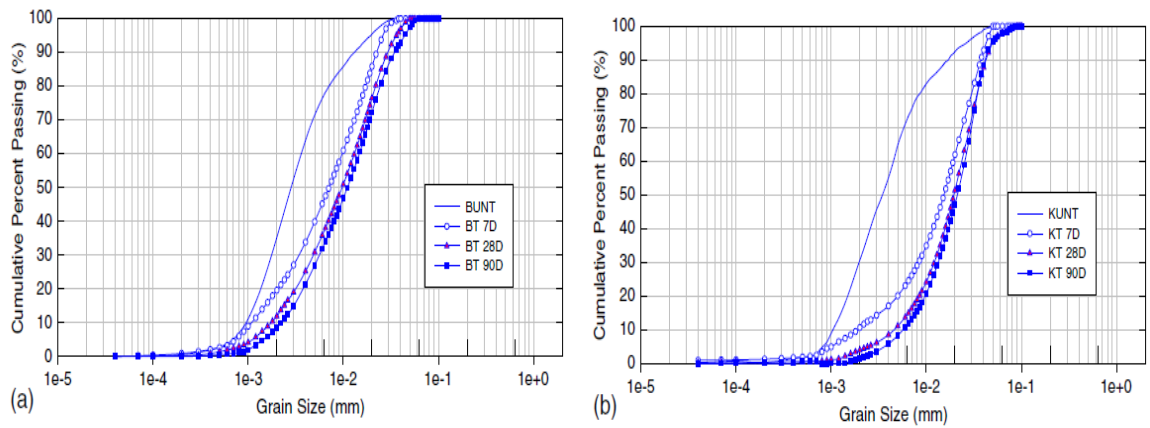

Figure 2.29. Particle size analysis tests (a) bentonite (b) kaolinite (Latifi et al., 2016)

Qureshi et al., (2017) treated a desert sand with different proportions of xanthan gum, i.e. 1.0, 2.0, 3.0 and 5.0%, and 10.0% cement of dry soil mass. Durability performance of these specimens was assessed by conducting slake durability tests. In these durability tests, ten pieces of each dry specimen weighing about 40-50 g were introduced into a wire mesh drum. Then, this drum was half-submerged in a water bath and then rotated at 20 revolutions for a minute. The specimens were then removed from the drum and dried at 105 °C for 2 hours. From the placement of the dry specimen into the drum to the removal of the sample after required revolutions and drying it constitutes one slaking cycle. The slake durability index is expressed as the percentage ratio of the total mass of specimens after two cycles to the original total mass. After two slaking cycles, it was noted that the slake durability index of the sand treated with 3.0% of xanthan gum was higher than that of the sand treated with 10.0% cement, indicating better durability performance of xanthan gum treated sand.

Very recently, Chen et al., (2019) investigated the effect of drying on xanthan gum treated sand. Sand treated with varying concentrations of xanthan gum (0.25-0.50% by mass) were prepared for different drying conditions. After preparation, the samples were fully immersed in water to achieve an initial state of 100% saturation. One set of samples were then dried at a room temperature of 20°C, while another set of samples were dried in an oven at 40°C. Drying of samples was done until target water content corresponding to 66%, 33% and 0% was achieved. At these saturation levels, direct shear tests were then performed under 50, 100, 200 and 300 kPa vertical stresses. It was reported that the oven dried samples showed a gradual improvement in strength with drying. Samples dried at room temperature showed variability in its strength, this was because the inner part of the samples remained moist, while the exterior surface was cemented and crystallised. For both drying conditions, the strengthening effect of xanthan was at a maximum when samples were completely dry.

### 2.4.3.4. Summary of biopolymer soil stabilisation

Based on the literature study, important aspects of biopolymer soil stabilisation are summarised herein.

1. The stabilisation mechanism of biopolymers varies depending on the soil type. In the case of sand, hydrogels coat the soil particles and increase the interparticle contact area, while in clays, biopolymers establish chemical bonds to provide stabilising effect (Chang et al., 2015). The intrinsic properties of biopolymer determine whether the nature of chemical bonding, i.e. hydrogen bonding and with or without ionic bonding (Chen et al., 2013).
2. The time taken to achieve significant strength for biopolymer treated soils seems to be relatively short. For sand, an improvement in strength was seen within 7 days of curing (Cabalar and Canakci, 2011), while for clays, significant improvements occur well within 28 days of curing (Latifi et al., 2016)
3. On drying, the nature of hydrogels tends to change from a thick rubbery state to a thin glassy state. This change leads to a higher compressive strength of soil as noted by Ayeldeen et al., (2016). Further, drying affects the time taken to achieve complete strength gain (C. Chen et al., 2019)
4. Chang et al., (2015) noted that, mixing soil and biopolymer in dry condition yielded higher compressive strength than wet mixed samples. This is an essential guideline for using biopolymers in practical applications.
5. Biopolymer concentrations in the range of 1.0 – 3.0% appear to be sufficient to achieve significant soil stabilisation to improve both strength and durability (Cabalar and Canakci, 2011; Chang, Im et al., 2015; Qureshi et al., 2017). Higher concentrations of biopolymer affect soil workability (Chang, Im et al., 2015).

### 2.4.4 Biopolymer soil stabilisation for earthen construction materials

Though bio-stabilisation techniques have been used historically for improving the strength and durability performance of earthen materials, the use of biopolymers for stabilisation in modern earthen construction is a novel idea. Only in the recent past have researchers attempted to use biopolymers as a stabiliser for earthen materials (Aguilar et al., 2016; Nakamatsu et al., 2017). Aguilar et al., (2016) attempted to stabilise a low plasticity clay used for manufacturing adobe with chitosan which is a synthetically substituted cellulose (varying concentration up to 3.0%). The performance of the biopolymer was evaluated both as a stabiliser and as a coating material. The mechanical behaviour of biopolymer treated samples was assessed through compressive, flexural and bending tests. Resistance against water-induced degradation was assessed via erosional tests. Based on the test results, it was reported that the mechanical performance of biopolymer treated materials was better than that of the untreated material. Further, the erosional tests indicated addition of chitosan improved resistance against water induced erosion

either as a surface coat or as a stabiliser. It was concluded that chitosan at 3.0% was sufficient to improve the strength and durability properties of earthen construction materials. On similar lines, Nakamatsu et al., (2017) investigated the effect of carrageenan (which is a biopolymer derived from algae) on mechanical and durability properties for the same soil used by Aguilar et al., (2016). It was reported that in the case of carrageenan, about 2.0% of concentration was sufficient to achieve significant stabilisation of the earthen material. These fairly rudimentary studies provide a brief outlook of using biopolymers as potential stabilisers for earthen materials. With this research background, this thesis aims to assess the potential of using biopolymer treated earthen material through geotechnical characterisation and assessment as a building material.

### 2.5 Concluding remarks

This chapter has discussed the historical overview of rammed earth and compressed earth blocks which led to the development of technical recommendations for manufacturing modern day earthen materials. Particle size distribution and soil plasticity have become the main parameters which define the suitability of the soil for its use in manufacturing earthen materials. Strength, durability, hygroscopic behaviour and recyclability potential are the desired engineering properties of modern earthen materials. Based on the past research, factors which influence these properties were discussed. It was noted that the addition of chemical stabilisers though has improved strength and durability, it has compromised hygroscopic behaviour and recyclability potential of the earthen material.

Basics of unsaturated soil mechanics were discussed in subsequent sections of the chapter. Phase relationships, soil suction and soil water retention curve, were discussed. Though limited studies report the role of suction in earthen materials, it was noted that suction plays a crucial role in the mechanical behaviour of earthen materials. Further, it was noted that a constitutive model to predict the strength of an earthen material could be developed based on the concepts of unsaturated soil mechanics.

The chapter ended with a discussion on biopolymer stabilisation, which can be a potential alternative to chemical stabilisers. Based on the literature review, it was noted that biopolymers have been effectively used to improve strength, permeability and durability of the soils in many geotechnical applications. It was noted that biopolymers provide stabilisation effect through the formation of hydrogels. Further, essential aspects concerning biopolymer stabilisation were summarised.

In the next chapter, findings from the preliminary study undertaken to understand the stabilisation effect of two biopolymers namely guar gum and xanthan gum is discussed.

### References

- AFNOR. 2001. XP P13-901; Compressed earth blocks for walls and partitions: definitions – Specifications – Test methods – Delivery acceptance conditions.
- Aguilar R, Nakamatsu J, Ramirez E, Elgegren M, Ayarza J, Kim S, ... Ortega-San-Martin L. 2016. The potential use of chitosan as a biopolymer additive for enhanced mechanical properties and water resistance of earthen construction. *Construction and Building Materials*, 114, 625–637.
- Al Aqtash U, and Bandini P. 2015. Prediction of unsaturated shear strength of an adobe soil from the soil-water characteristic curve. *Construction and Building Materials*, 98, 592–599.
- Alley PJ. 1948. *Rammed Earth Construction*. New Zealand Engineering.
- Allinson D, and Hall M. 2012. Humidity buffering using stabilised rammed earth materials. *Proceedings of the Institution of Civil Engineers - Construction Materials*, 165(6), 335–344.
- Alonso EE, Gens A, and Josa A. 1991. Discussion: A constitutive model for partially saturated soils. *Géotechnique*, 41(2), 273–275.
- Aminpour M, and O’Kelly BC. 2015. Applications of biopolymers in dam construction and operation activities. In D. I. and S. R. Pina C., Portela E., Caldeira L., Batista A. (Ed.), *Proceedings of the Second International Dam World Conference (DW2015)* (pp. 937–946). Lisbon, Portugal: LNEC.
- Arrigoni A, Grillet AC, Pelosato R, Dotelli G, Beckett C, Woloszyn M, and Ciancio D. 2017. Reduction of rammed earth’s hygroscopic performance under stabilisation: an experimental investigation. *Building and Environment*, 115, 358–367.
- ASTM-D559. 1989. *Wetting and Drying Compacted Soil- Cement Mixtures*. Philadelphia: American Society for Testing and Materials.
- Aubert JE, Maillard P, Morel JC, and Al Rafii M. 2016. Towards a simple compressive strength test for earth bricks? *Materials and Structures*, 49(5), 1641–1654.
- Australia S. 2002. *The Australian Earth Building Handbook*. Sydney, Australia.
- Ayeldeen MK, Negm AM, and El Sawwaf MA. 2016. Evaluating the physical characteristics of biopolymer/soil mixtures. *Arabian Journal of Geosciences*, 9(5), 329–339.
- Babu NGR, Anitha N, and Rani RHK. 2010. Recent trends in biodegradable products from biopolymers. *Recent Trends in Biodegradable Products from Biopolymers*, 9(11), 30–34.
- Baker R, and Frydman S. 2009. Unsaturated soil mechanics. *Engineering Geology*, 106(1–2), 26–39.
- Becker A, Katzen F, Pühler A, and Ielpi L. 1998. Xanthan gum biosynthesis and application: A biochemical/genetic perspective. *Applied Microbiology and Biotechnology*, 50(2), 145–152.
- Beckett C. 2011. *The Role of Material Structure in Compacted Earthen Building Materials: Implications for Design and Construction*. Durham University. Retrieved from <http://etheses.dur.ac.uk/3313/>
- Beckett C, and Augarde C. 2012. The effect of humidity and temperature on the compressive strength of rammed earth. In *Unsaturated Soils: Research and Applications* (pp. 287–292). Berlin, Heidelberg: Springer Berlin Heidelberg.
- Beckett C, Augarde CE, Easton D, and Easton T. 2017. Strength characterisation of soil-based construction materials. *Géotechnique*.
- Beckett C, and Ciancio D. 2016. Durability of cement-stabilised rammed earth: a case study in Western Australia. *Australian Journal of Civil Engineering*, 14(1), 54–62.
- Bouazza A, Gates WP, and Ranjith PG. 2009. Hydraulic conductivity of biopolymer-treated silty sand. *Géotechnique*, 59(1), 71–72.
- Brax M, Buchmann C, and Schaumann GE. 2017. Biohydrogel induced soil-water interactions: how to untangle the gel effect? A review. *Journal of Plant Nutrition and Soil Science*, 180(2), 121–141.
- Bruno AW, Gallipoli D, Perlot C, and Mendes J. 2016. Effect of very high compaction pressures on the physical and mechanical properties of earthen materials. In P. Delage, Y.-J. Cui, S. Ghabezloo, J.-M. Pereira, & A.-M. Tang (Eds.), *3rd European Conference on Unsaturated Soils – “E-UNSAT 2016”* (Vol. 9, p. 14004).
- Bruno AW, Gallipoli D, Perlot C, and Mendes J. 2017. Effect of stabilisation on mechanical properties, moisture buffering and water durability of hypercompacted earth. *Construction and Building Materials*, 149, 733–740.
- Bryan AJ. 1988. Criteria for the suitability of soil for cement stabilization. *Building and Environment*, 23(4), 309–319.
- BS 1377-2. 1990. *Methods of test for Soils for civil engineering purposes - Part 2: Classification tests*. London: BSI.
- Bui QB, Morel JC, Hans S, and Walker P. 2014. Effect of moisture content on the mechanical characteristics of rammed earth. *Construction and Building Materials*, 54, 163–169.
- Bui QB, Morel JC, Venkatarama Reddy B, and Ghayad W. 2009. Durability of rammed earth walls exposed for 20 years to natural weathering.

## Chapter 2. Literature Review

---

- Building and Environment, 44(5), 912–919.
- Burroughs S. 2008. Soil Property Criteria for Rammed Earth Stabilization. *Journal of Materials in Civil Engineering*, 20(3), 264–273.
- Burroughs S. 2010. Recommendations for the Selection, Stabilization, and Compaction of Soil for Rammed Earth Wall Construction. *Journal of Green Building*, 5(1), 101–114.
- Cabalar AF, and Canakci H. 2011. Direct shear tests on sand treated with xanthan gum. *Proceedings of the ICE - Ground Improvement*, 164, 57–64.
- Champiré F, Fabbri A, Morel J-C, Wong H, and McGregor F. 2016. Impact of relative humidity on the mechanical behavior of compacted earth as a building material. *Construction and Building Materials*, 110, 70–78.
- Chang I, Im J, and Cho G-C. 2016. Introduction of Microbial Biopolymers in Soil Treatment for Future Environmentally-Friendly and Sustainable Geotechnical Engineering. *Sustainability*, 8(3), 251.
- Chang I, Im J, Prasadhi AK, and Cho G-C. 2015. Effects of Xanthan gum biopolymer on soil strengthening. *Construction and Building Materials*, 74(10), 65–72.
- Chang I, Prasadhi AK, Im J, and Cho G-C. 2015. Soil strengthening using thermo-gelation biopolymers. *Construction and Building Materials*, 77(2015), 430–438.
- Chen C, Wu L, Perdjou M, Huang X, and Peng Y. 2019. The drying effect on xanthan gum biopolymer treated sandy soil shear strength. *Construction and Building Materials*, 197, 271–279.
- Chen R, Zhang L, and Budhu M. 2013. Biopolymer Stabilization of Mine Tailings. *Journal of Geotechnical and Geoenvironmental Engineering*, 139(October), 130128212232006.
- Chudzickowski RJ. 1971. Guar gum and its applications. *Journal of the Society of Cosmetic Chemists*, 22(1), 43–60.
- Ciancio D, and Boulter M. 2012. Stabilised rammed earth: a case study in Western Australia. *Proceedings of the Institution of Civil Engineers - Engineering Sustainability*, 165(2), 141–154.
- CID-GCB-NMBC-14.7.4. 2006. New Mexico Earthen Building Materials Code. Santa Fe, NM.: Construction Industries Division of the Regulation and Licensing.
- Cointeraux F. 1791. *Ecole d'architecture rurale*. Premier, deuxième, troisième et quatrième cahier. Vezard & Le Normant.
- CRATerre-EAG: Rigassi V. 1995. Compressed earth blocks, vol. 1: manual of production. Braunschweig, Allemagne: Friedrich Vieweg & Sohn.
- CRATerre-EAG. 1998. CDI, Compressed earth blocks: Standards – Technology series No.11. Brussels: CDI.
- Dachverband Lehm e.V. 2009. *Lehmbau Regeln – Begriffe, Baustoffe, Bauteile* (3rd Edition). Wiesbaden, Germany: Vieweg + Teubner.
- Deboucha S, and Hashim R. 2011. A review on bricks and stabilized compressed earth blocks, 6(3), 499–506.
- Delage P. 2002. Experimental unsaturated soil mechanics. *Proc. 3rd Int. Conf. on Unsaturated Soils, UNSAT, 1961(3)*, 973–996.
- DIN18945. 2013. Earth blocks - Terms and definitions, requirements, test methods.
- EBAA. 2004. Building with earth bricks & rammed earth in Australia. Wangaratta: Earth Building Association of Australia EBAA.
- Etzion Y, and Saller M. 1987. Earth Construction—A Review of Needs and Methods. *Architectural Science Review*, 30(2), 43–48.
- Fabbri A, Morel J-C, and Gallipoli D. 2018. Assessing the performance of earth building materials: a review of recent developments. *RILEM Technical Letters*, 3, 46–58.
- Fitzmaurice R. 1958. *Manual on stabilized soil construction for housing*. New York: United Nations, Technical Assistance Programme.
- Font F, and Hidalgo P. 1991. *El Tapial—Una Técnica Constructiva* Mil Lenaria.
- Fredlund D., and Xing A. 1994. Equations for the soil-water characteristic curve. *Canadian Geotechnical Journal*, 31(4), 521–532.
- Fujita Y, Ferris FG, Lawson RD, Colwell FS, and Smith RW. 2000. Subscribed content calcium carbonate precipitation by ureolytic subsurface bacteria. *Geomicrobiology Journal*, 17(4), 305–318.
- Fullerton RLC. 1967. *Building construction in warm climates*.
- Gallipoli D, Bruno AW, Perlot C, and Mendes J. 2017. A geotechnical perspective of raw earth building. *Acta Geotechnica*, 12(3), 463–478.
- Gallipoli D, Gens A, Sharma R, and Vaunat J. 2003. An elasto-plastic model for unsaturated soil incorporating the effects of suction and degree of saturation on mechanical behaviour. *Géotechnique*, 53(1), 123–136.
- García-Ochoa F, Santos VE, Casas JA, and Gomez E. 2000. Xanthan gum: production, recovery, and properties. *Biotechnology Advances*, 18(7), 549–579.
- Gens A. 2010. Soil–environment interactions in geotechnical engineering. *Géotechnique*, 60(1), 3–74.

## Chapter 2. Literature Review

---

- Gerard P, Mahdad M, Robert McCormack A, and Francois B. 2015. A unified failure criterion for unstabilized rammed earth materials upon varying relative humidity conditions. *Construction and Building Materials*, 95, 437–447.
- Gerlach G, and Arndt K-F. 2009. *Hydrogel sensors and actuators: engineering and technology* (Vol. 6). Springer Science & Business Media.
- Gerrard C. 2003. Paisaje y sen̄orio. La casa conventual de Ambel (Zaragoza): arquitectura e historia de las 6rdenes militares del Temple y del Hospital. Zaragoza.
- Gooding D. 1993. Soil Testing for Soil-Cement Block Preparation (No. Working Paper No. 38.).
- Guettala A, Abibsi A, and Houari H. 2006. Durability study of stabilized earth concrete under both laboratory and climatic conditions exposure. *Construction and Building Materials*, 20(3), 119–127.
- Heathcote KA. 1995. Durability of earthwall buildings. *Construction and Building Materials*, 9(3), 185–189.
- Hillel D. 1998. *Environmental Soil Physics*. California (USA): Academic Press.
- Houben H, and Guillaud H. 1994. *Earth construction: a comprehensive guide*. Intermediate Technology Publications.
- Hughes R. 1983. Material and structural behaviour of soil constructed walls. *Monumentum*, 26(3), 175–188.
- IS-2110. 1980. Code of practice for in-situ construction of walls, in buildings with soil-cement. New Delhi: Bureau of Indian Standards.
- IS 1725. 2013. Indian Standard IS 1725: Stabilized soil blocks used in general building construction — Specification. New Delhi: Bureau of Indian Standards.
- Ivanov V, and Stabnikov V. 2016. *Construction Biotechnology: Biogeochemistry, Microbiology and Biotechnology of Construction Materials and Processes*. Springer.
- Jaquin PA, Augarde CE, Gallipoli D, and Toll DG. 2009. The strength of unstabilised rammed earth materials. *Géotechnique*, 59(5), 487–490.
- Jaquin PA, Augarde CE, and Gerrard CM. 2008. Chronological Description of the Spatial Development of Rammed Earth Techniques. *International Journal of Architectural Heritage*, 2(4), 377–400.
- Jiménez Delgado MC, and Guerrero IC. 2007. The selection of soils for unstabilised earth building: A normative review. *Construction and Building Materials*, 21(2), 237–251.
- Jiyao H, and Weitung J. 1990. Earth-culture-architecture: the protection and development of rammed earth and adobe architecture in China. In *6th International Conference on the Conservation of Earthen Architecture: Adobe 90 preprints: Las Cruces, New Mexico, USA, October 14-19, 1990* (pp. 72–76).
- Katzbauer B. 1998. Properties and applications of xanthan gum. *Polymer Degradation and Stability*, 59(1–3), 81–84.
- Kerali AG. 2001. *Durability of Compressed and Cement Stabilised Building Blocks*. University of Warwick.
- Khatami HR, and O’Kelly BC. 2013. Improving mechanical properties of sand using biopolymers. *Journal of Geotechnical and Geoenvironmental Engineering*, 139(8), 1402–1406.
- Kouakou CH, and Morel JC. 2009. Strength and elastoplastic properties of non-industrial building materials manufactured with clay as a natural binder. *Applied Clay Science*, 44(1–2), 27–34.
- Krayenhoff M. 2012. North American modern earth construction. In *Modern Earth Buildings* (pp. 561–608). Elsevier.
- Latifi N, Horpibulsuk S, Meehan CL, Abd Majid MZ, Tahir MM, and Mohamad ET. 2016. Improvement of Problematic Soils with Biopolymer—An Environmentally Friendly Soil Stabilizer. *Journal of Materials in Civil Engineering*, 29(2).
- Lax C. 2010. Life cycle assessment of rammed earth. University of Bath. Retrieved from [http://www.ebuk.uk.com/docs/Dissertation\\_Clar e\\_Lax.pdf](http://www.ebuk.uk.com/docs/Dissertation_Clar e_Lax.pdf)
- Likos WJ. 2000. Total Suction–Moisture Content Characteristics for Expansive Soils. Colorado School of Mines, Golden, CO. Retrieved from <https://mountainscholar.org/handle/11124/78530>
- Lu N, and Likos WJ. 2004. *Unsaturated Soil Mechanics*. Wiley.
- Maniatidis V, and Walker P. 2003. *A Review of Rammed Earth Construction*. Bath, United Kingdom.
- Maskell D, Heath A, and Walker P. 2014. Comparing the Environmental Impact of Stabilisers for Unfired Earth Construction. *Key Engineering Materials*, 600, 132–143.
- McGregor F, Heath A, Fodde E, and Shea A. 2014. Conditions affecting the moisture buffering measurement performed on compressed earth blocks. *Building and Environment*, 75, 11–18.
- McGregor F, Heath A, Maskell D, Fabbri A, and Morel J-C. 2016. A review on the buffering capacity of earth building materials. *Proceedings of the Institution of Civil Engineers - Construction Materials*, 169(5), 241–251.

## Chapter 2. Literature Review

---

- McGregor F, Heath A, Shea A, and Lawrence M. 2014. The moisture buffering capacity of unfired clay masonry. *Building and Environment*, 82, 599–607.
- McHenry PG. 1984. Adobe and rammed earth buildings: design and construction. University of Arizona.
- McQueen IS, and Miller RF. 1974. Approximating soil moisture characteristics from limited data: Empirical evidence and tentative model. *Water Resources Research*, 10(3), 521–527.
- Michon J-L. 1990. Mud castles (kasbas) of south Morocco-will they survive? In 6th International Conference on the Conservation of Earthen Architecture: Adobe 90 preprints: Las Cruces, New Mexico, USA, October 14-19, 1990 (pp. 99–104).
- Middleton GF, and Schneider LM. 1987. Bulletin 5: Earth-Wall Construction (Vol. 5). Sydney, Australia: CSIRO.
- Montgomery D. 1998. Physical characteristics of soils that encourage SSB breakdown during moisture attack. (Stabilised Soil Research Progress Report SSRPR03).
- MOPT. 1992. Bases Para el Diseño y Construcción con Tapial. Madrid, Spain: Centro de Publicaciones., Secretaría General Técnica, Ministerio de Obras Públicas y Transportes.
- Morel JC, Bui QB, and Hamard E. 2012. Weathering and durability of earthen material and structures. In *Modern Earth Buildings* (pp. 282–303). Elsevier.
- Morel JC, Pkila A, and Walker P. 2007. Compressive strength testing of compressed earth blocks. *Construction and Building Materials*, 21(2), 303–309.
- Moriarty J, Svare T, and Therkildsen O. 1975. Soil-cement for low-cost housing. Norges Byggeforsknings Institutt.
- Mudgil D, Barak S, and Khatkar BS. 2011. Guar gum: processing, properties and food applications—A Review. *Journal of Food Science and Technology*, 51(6), 409–418.
- Mukerji K. 1986. Soil block presses. Publication of Deutsches Zentrum fr Entwicklungstechnologien – GATE, a Division of the Deutsche Gesellschaft fr Technische Zusammenarbeit (GTZ) GmbH.
- Nagaraj HB, Rajesh A, and Sravan MV. 2016. Influence of soil gradation, proportion and combination of admixtures on the properties and durability of CSEBs. *Construction and Building Materials*, 110, 135–144.
- Nakamatsu J, Kim S, Ayarza J, Ramírez E, Elgegren M, and Aguilar R. 2017. Eco-friendly modification of earthen construction with carrageenan: Water durability and mechanical assessment. *Construction and Building Materials*, 139, 193–202.
- NBR-13354. 1996. Solo-cimento - Ensaio de durabilidade por molhagem e secagem. Rio de Janeiro: ABNT-Associação Brasileira de Normas Técnicas.
- Niroumand H, Zain MFM, and Jamil M. 2012. Modern Rammed Earth in Earth Architecture. *Advanced Materials Research*, 457–458, 399–402.
- Nishimura T, and Fredlund DG. 2002. Hysteresis effects resulting from drying and wetting under relatively dry conditions. In *Proceeding of the 3th International Conference of Unsaturated Soil* (pp. 301–306). The Netherlands.
- Norton J. 1997. *Building with Earth. A handbook (Second Edi)*. London: Intermediate Technology Publications.
- Note-164. 1994. Recommendations for the Testing and Use of Constructions Materials, RILEM Technical committee.
- Nowamooz H, and Chazallon C. 2011. Finite element modelling of a rammed earth wall. *Construction and Building Materials*, 25(4), 2112–2121.
- Nuth M, and Laloui L. 2008. Advances in modelling hysteretic water retention curve in deformable soils. *Computers and Geotechnics*, 35(6), 835–844.
- NZS 4297. 1998. Engineering design of earth buildings (Vol. 4297). Wellington: Standards New Zealand.
- NZS 4298. 1998. Materials and workmanship for earth buildings [Building Code Compliance Document E2 (AS2)]. New Zealand Technical Committee. Wellington: Standards New Zealand.
- Ogunye FO, and Boussabaine H. 2002. Diagnosis of assessment methods for weatherability of stabilised compressed soil blocks. *Construction and Building Materials*, 16(3), 163–172.
- Olivier M, and Mesbah A. 1986. Le matériau terre: Essai de compactage statique pour la fabrication de briques de terre compressées. *Bull.liaison Labo P. et Ch*, 146(January), 37–43.
- Olivier M, and Mesbah A. 1987. Influence of different parameters on the resistance of earth, used as a building material. In *International Conference on Mud Architecture*, Trivandrum, India (Vol. 25).
- Oudhof N, Labat M, Magniont C, and Nicot P. 2015. Measurement of the hygrothermal properties of straw-clay mixtures. In *First International Conference on Bio-based Building Materials* (pp. 474–479).
- Pacheco-Torgal F, Ivanov V, Karak N, and Jonkers H. 2016. *Biopolymers and Biotech Admixtures for Eco-Efficient Construction Materials*. Woodhead Publishing.

## Chapter 2. Literature Review

---

- Pacheco-Torgal F, and Labrincha J a. 2013. Biotechnologies and bioinspired materials for the construction industry: an overview. *International Journal of Sustainable Engineering*. Taylor & Francis.
- Padfield T. 1998. The role of absorbent building materials in moderating changes of relative humidity. Department of Structural Engineering and Materials, Lyngby, Technical University of Denmark.
- Philip JR. 1977. Unitary approach to capillary condensation and adsorption. *The Journal of Chemical Physics*, 66(11), 5069–5075.
- Plank J. 2004. Applications of biopolymers and other biotechnological products in building materials. *Applied Microbiology and Biotechnology*, 66(1), 1–9.
- Plank J. 2005. Applications of Biopolymers in Construction Engineering. In A. Steinbüchel (Ed.), *Biopolymers Online*. Weinheim, Germany: Wiley-VCH Verlag GmbH & Co. KGaA.
- Qureshi MU, Bessaih N, Al K, Al-Falahi S, and Al-Mandhari A. 2014. Shear Strength of Omani sand Treated with Biopolymer. In 7th International Congress on Environmental Geotechnics. Melbourne, Australia.
- Qureshi MU, Chang I, and Al-Sadarani K. 2017. Strength and durability characteristics of biopolymer-treated desert sand. *Geomechanics and Engineering*, 12(5), 785–801.
- Reddy B, and Jagadish JS. 1989. Properties of soil-cement block masonry. *Masonry International*, 3(2), 80–84.
- Reddy B, and Jagadish KS. 1995. Influence of soil composition on the strength and durability of soil-cement blocks. *Indian Concrete Journal*, 69(9), 517–524.
- Reddy B, and Kumar PP. 2009. Role of clay content and moisture on characteristics of cement stabilised rammed earth. In *Proceedings of the 11th International Conference on Non-Conventional Materials and Technologies (NOCMAT)*. Bath University.
- Reddy B, and Kumar PP. 2011a. Cement stabilised rammed earth. Part A: Compaction characteristics and physical properties of compacted cement stabilised soils. *Materials and Structures/Materiaux et Constructions*, 44(3), 681–693.
- Reddy B, and Kumar PP. 2011b. Cement stabilised rammed earth. Part B: compressive strength and stress-strain characteristics. *Materials and Structures*, 44(3), 695–707.
- Reddy B, Lal R, and Rao KN. 2007. Optimum Soil Grading for the Soil-Cement Blocks. *Journal of Materials in Civil Engineering*, 19(2), 139–148.
- Reddy B, and Latha MS. 2014. Influence of soil grading on the characteristics of cement stabilised soil compacts. *Materials and Structures*, 47(10), 1633–1645.
- Reitermann R. 2001. Chapel Of Reconciliation. Retrieved from <https://www.archilovers.com/projects/503/gallery?333517>
- Renforth P, Manning DAC, and Lopez-Capel E. 2009. Carbonate precipitation in artificial soils as a sink for atmospheric carbon dioxide. *Applied Geochemistry*, 24(9), 1757–1764.
- Rigassi V. 1985. *Compressed Earth Blocks: Manual of Production*. Network (Vol. D).
- Rode C. 2005. *Moisture Buffering of Building Materials* Department of Civil Engineering Technical University of Denmark.
- Rode C, Peuhkuri R, Mortensen LH, Hansens K, Time B, Gustavsen A, ... Harderup LE. 2005. *Moisture Buffering of Building Materials*, Report BYG-DTU R-126, ISSN 1601-2917. ISBN 87-7877-195.
- Rojas E, and Rojas F. 2005. Modeling hysteresis of the soil-water characteristic curve. *SOILS AND FOUNDATIONS*, 45(3), 135–145.
- Rong H, Qian C, and Wang R. 2011. A cementation method of loose particles based on microbe-based cement. *Science China Technological Sciences*, 54(7), 1722–1729.
- SAZS-724. 2001. *Standard Code of Practice for Rammed Earth Structures*. Harare.
- Schroeder H. 2016. *Sustainable Building with Earth*. Sustainable Building with Earth. Cham: Springer International Publishing.
- Selvanayagam P. 1970. *Soil Cement Blocks For Low Cost Housing -- Correlation of Experimental Results With Site Observations*.
- SIA. 1994. *Regeln zum Bauen mit Lehm/Lehmbau-Atlas, Dokumentationen*. Zurich, Switzerland: Schweizerischer Ingenieur- und Architekten-Verein.
- SLS-1382-3. 2009. *Specification for compressed stabilized earth blocks. Part 3: Guidelines on production, design and construction*. Sri Lanka: SLSI.
- Smith EW, and Austin GS. 1989. *Adobe, pressed-earth, and rammed-earth industries in New Mexico*.
- Spence RJS. 1975. *Predicting the Performance of Soil-cement as a Building Material in Tropical Countries*. Building Science, 10.
- Stabnikov V, Ivanov V, and Chu J. 2015. *Construction Biotechnology: a new area of biotechnological research and applications*. *World Journal of Microbiology and Biotechnology*, 31(9), 1303–1314.

## Chapter 2. Literature Review

---

- Tarantino A. 2007. A possible critical state framework for unsaturated compacted soils. *Géotechnique*, 57(4), 385–389.
- Tarantino A. 2009. A water retention model for deformable soils. *Géotechnique*, 59(9), 751–762.
- Terzaghi K, Peck BR, and Mesri G. 1963. *Soil Mechanics in Engineering Practice* (Third Edit). A Wiley-Interscience Publication.
- Thombare N, Jha U, Mishra S, and Siddiqui MZ. 2016. Guar gum as a promising starting material for diverse applications: A review. *International Journal of Biological Macromolecules*, 88(April), 361–372.
- Toll D, Asquith J, Fraser A, Hassan A, Liu G, Lourenço S, ... Stirling R. 2015. Tensiometer techniques for determining soil water retention curves. In *Unsaturated Soil Mechanics - from Theory to Practice* (pp. 15–22). CRC Press.
- Treloar G, Fay R, Ilozor B, and Love P. 2001. Building materials selection: greenhouse strategies for built facilities. *Facilities*, 19(3/4), 139–150.
- Tuller M, and Or D. 2005. WATER RETENTION AND CHARACTERISTIC CURVE. In *Encyclopedia of Soils in the Environment* (pp. 278–289). Elsevier.
- UNE41410. 2008. Compressed earth blocks for walls and partitions. Definitions, specifications and test methods. Madrid (Spain): Spanish Association for Standardisation and Certification.
- UNHCS. 1976. Report of HABITAT, A/CONF. Vancouver.
- United Nations. 1964. *Soil-cement, its use in building*. New York.
- Verma PL, and Mehra SR. 1950. Use of soil-cement in house construction in the Punjab. *Indian Concr J*, 24(4), 91–96.
- VITA. 1975. *Making buildings blocks with the CINVA-Ram block press, volunteers in technical assistance*. London: Intermediate Technology Publications.
- Vyncke J, Kupers L, and Denies N. 2018. Earth as Building Material - An overview of RILEM activities and recent Innovations in Geotechnics. *MATEC Web of Conferences*, 149, 1–7.
- Walker P. 1995. Strength, durability and shrinkage characteristics of cement stabilised soil blocks. *Cement and Concrete Composites*, 17(4), 301–310.
- Walker P. 1997. Characteristics of Pressed Earth Blocks in Earth Blocks. In *11th International Brick/Block Masonry Conference in Tonji University* (pp. 14–16). Shanghai, China.
- Walker P. 2002. Standards Australia, 2002. HB 195: *The Australian Earth Building Handbook*.
- Walker P, Keable R, Martin J, and Maniatidis V. 2005. *Rammed earth: design and construction guidelines*. BRE Bookshop Watford.
- Walker P, and Stace T. 1997. Properties of some cement stabilised compressed earth blocks and mortars. *Materials and Structures/Materiaux et Constructions*, 30(203), 545–551.
- Wallis RK. 2012. Modern rammed earth construction in China. *Modern Earth Buildings: Materials, Engineering, Constructions and Applications*, 688–711.
- Webb D. 1983. Stabilized soil construction in Kenya. In *International conference on economical housing in developing countries*. Paris: UNESCO.
- Yang F, Zhang B, and Ma Q. 2010. Study of sticky rice-lime mortar technology for the restoration of historical masonry construction. *Accounts of Chemical Research*, 43(6), 936–944.
- Yang H, Rahardjo H, Leong E-C, and Fredlund DG. 2004. Factors affecting drying and wetting soil-water characteristic curves of sandy soils. *Canadian Geotechnical Journal*, 41(5), 908–920.

# Chapter 3

## Biopolymer Stabilisation

### 3.1 Introduction

To understand the potential of using biopolymers as an alternative stabiliser for earthen materials, an exploratory campaign involving strength tests, qualitative macrostructural analyses and preliminary durability tests were conducted. The testing methodology and findings of this campaign are presented in this chapter.

### 3.2 Materials

#### 3.2.1 Engineered soil mixture

In order to obtain an earthen construction material with acceptable compressive strength, the particle size distribution of the soil used in the preparation of the material should be within the recommended limits given by different international standards (Houben and Guillaud, 1994). However, in many scenarios, the natural soil at the site may not satisfy these requirements. In this situation, the soil is usually engineered by combining the dry soil components in required proportions to obtain a material possessing the desired particle gradation (Hall and Djerbib, 2004). Thus, soils used to prepare rammed earth or compressed earth blocks are appropriately termed as “soil mixes” indicating that the material is manufactured (Beckett, 2011). Engineering a soil mix ensures that the properties of the prepared mix remains consistent in regards to its particle size distribution and plasticity properties. The most commonly recommended soil proportion used for manufacturing earthen construction material is the one containing 70% sand and clay content at around 15% (Maniatidis and Walker, 2003; Jiménez Delgado and Guerrero, 2007). In adherence with these recommendations, an engineered soil mix denoted as ‘2-7-1’ containing 20% fine fraction, 70% sand and 10% gravel by mass is considered in this and subsequent investigations of the thesis. By choosing this soil proportion, it was ensured that the soil mix is favourable for preparing both unstabilised and cement stabilised earthen construction materials.

To prepare the soil mix, all the ingredients namely the fine fraction, sand and gravel were initially assembled. For the fine portion, industrial kaolin was procured from M/s IMERYYS, United Kingdom, while sand and gravel were procured from M/s J T Dove limited, United Kingdom. The clay mineralogy is described as kaolinite and chemical analysis by X-ray fluorescence showed SiO<sub>2</sub> 47% and Al<sub>2</sub>O<sub>3</sub> 38% by dry mass (IMERYYS, 2007). By choosing kaolin, it is ensured that the principal clay mineral in the soil mix is kaolinite, which is recommended for earthen construction as it is less susceptible to volume changes on drying and wetting (Etzion and Saller, 1987; Walker et al., 2005). Sharp sand passing through a 2.36mm sieve was prepared. The gravel-sized particles from the sand were removed in order to ensure that the

gravel content in the soil mix was precisely added. The gravel component of the soil mix was prepared by sieving it through a 10mm sieve. These three components were combined in the appropriate proportion to obtain the required soil mix. For the prepared soil mix different physical properties such as particle size distribution, Atterberg limits, linear shrinkage, and compaction characteristics (using the 2.5kg Proctor test) were determined.

The particle size gradation for the soil mix was obtained through wet sieving and sedimentation analysis as specified by BS 1377-2 (1990). Sieve analysis was performed for the coarse fraction retained on a 63  $\mu\text{m}$  sieve and sedimentation analysis for the fine fraction which passed through the 63  $\mu\text{m}$  sieve. Figure 3.1 shows the particle size distribution curve for the engineered soil mix along with the recommended limits of soil grading (MOPT, 1992; Houben and Guillaud, 1994; AFNOR, 2001). It can be observed from the figure that the particle size distribution of the engineered soil mix lies within the recommended limits of soil grading for both rammed earth and compressed earth blocks.

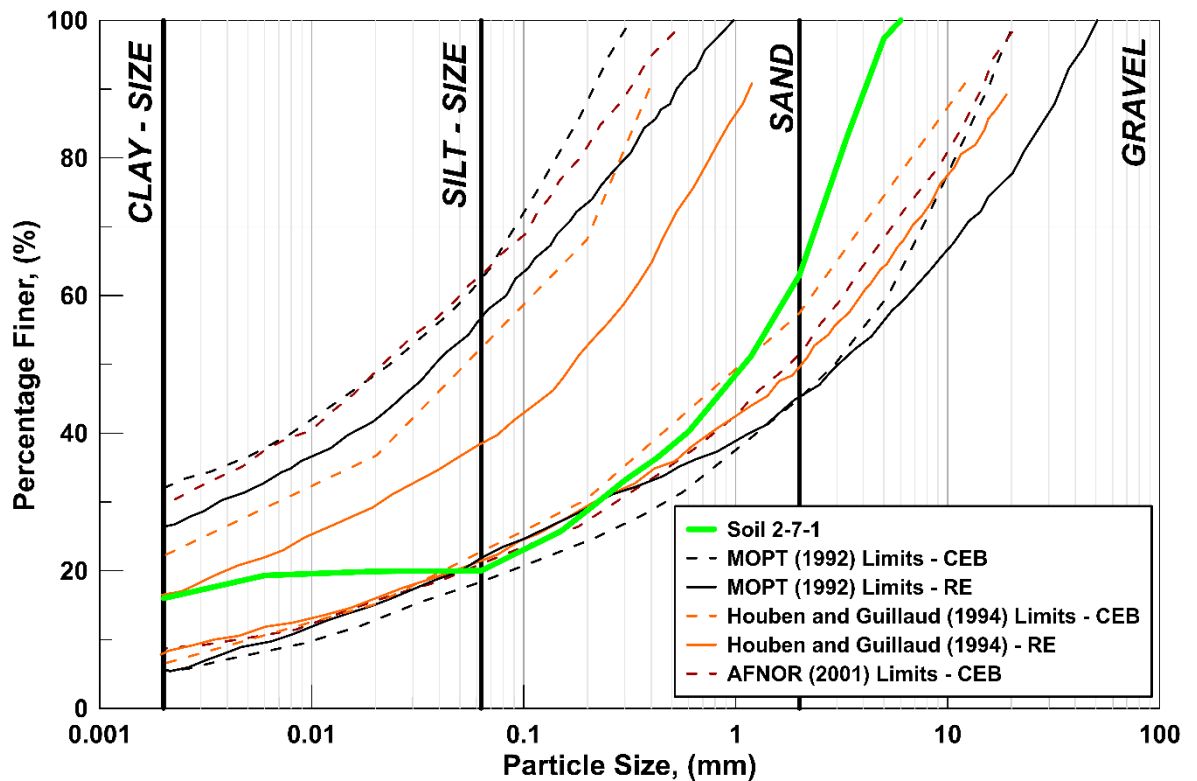

Figure 3.1. Particle size distribution for the engineered soil mix

For the engineered soil mix, Atterberg limits and linear shrinkage are determined for the soil fraction passing the 425  $\mu\text{m}$  sieve. For determining Atterberg limits, the sieved soil fraction was mixed thoroughly with deionized water until a stiff consistency was achieved. After mixing, the mixture was left to equilibrate in air-tight polythene bags for 24 hours, after which Atterberg limits and linear shrinkage were determined in accordance with the British standard (BS 1377-2, 1990) and results are tabulated in Table 3.1. The cone penetration method was used to determine the liquid limit of the soil mixture. The test was conducted progressively from stiff

to soft consistency on the equilibrated soil mix, so as to obtain a minimum of five points for plotting the flow curve. It was ensured that these points fell within the consistency range corresponding to 15 mm to 25 mm of penetration depth. Liquid limit of the specimen, i.e. the water content corresponding to 20 mm cone penetration was later extrapolated from the flow curve. For determining the plastic limit, the equilibrated sample in stiff consistency was spread across a glass plate to dry and at regular intervals the sample was worked along to achieve a uniform dry mixture. This process of drying and mixing the soil was continued until visible cracks started to appear on the soil surface when rolled into 3 mm threads. The water content corresponding to this point was noted as the plastic limit of the soil. The plastic limit values are average of two trials. To obtain linear shrinkage, some portion of the soil from the liquid limit test corresponding to liquid limit consistency, i.e. (around 20 mm cone penetration) was spread uniformly into a shrinkage tray. Air pockets were carefully removed and the tray was left to air dry for 24 hours. After 24 hours, the soil in the tray was oven dried for another 24 hours. Based on the initial and final lengths of the sample the linear shrinkage of the sample was calculated.

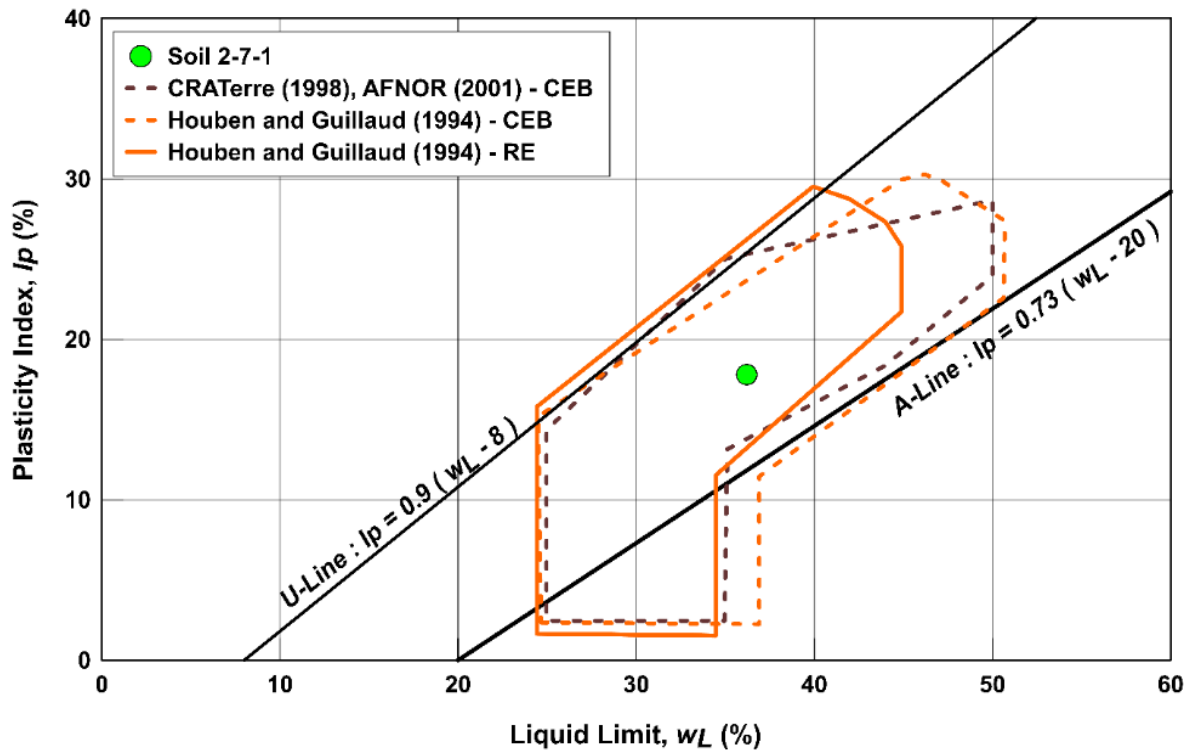

Figure 3.2. Plasticity properties of the engineered soil mix

In Figure 3.2, the liquid limit and the plasticity index of the engineered soil mix are plotted on the plasticity chart along with recommended limits for earthen materials (Houben and Guillaud, 1994; CRATerre-EAG., 1998; AFNOR, 2001). From the figure, it can be noted that the plasticity properties of the engineered soil mix are well within the recommended limits. In addition, based on the plasticity properties and linear shrinkage values, it can be considered that the soil is favourable for cement stabilisation as per the recommendations given by Burroughs (2008).

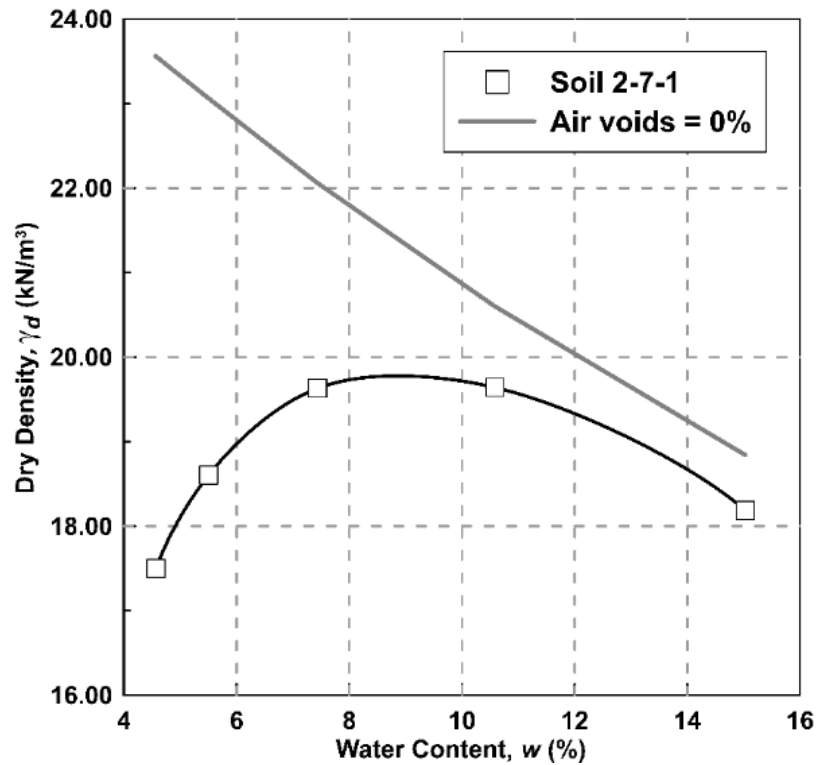

Figure 3.3. Compaction characteristics of the engineered soil mix

Following the work of Hall and Djerbib (2004), Walker et al., (2005) and Bui and Morel (2009), the compaction properties of the engineered soil mix, i.e. optimum water content (OWC) and max dry density ( $\gamma_{d,max}$ ) were determined by performing light Proctor tests as per BS 1377-4 (1990). For the engineered soil, the OWC was found to be 9.8% and  $\gamma_{d,max}$  was 19.62 kN/m<sup>3</sup>. The results of the compaction tests are presented in Figure 3.3. In this thesis, all earthen construction materials (unstabilised, biopolymer and cement stabilised) are manufactured under controlled density to achieve the maximum dry density of the engineered soil mix. Table 3.1 summarises the different physical properties of the soil mixture used in this study.

Table 3.1. Physical properties of the unstabilised soil mixture.

| Soil  | Clay (%) | Silt (%) | Sand (%) | Gravel (%) | Liquid Limit (%) | Plastic Limit (%) | Linear Shrinkage (%) | OWC (%) | $\gamma_{d,max}$ (kN/m <sup>3</sup> ) |
|-------|----------|----------|----------|------------|------------------|-------------------|----------------------|---------|---------------------------------------|
| 2-7-1 | 16       | 04       | 70       | 10         | 36.2             | 18.4              | 05                   | 9.8     | 19.62                                 |

### 3.2.2 Biopolymers

The two chosen biopolymers namely guar gum and xanthan gum were procured from M/s Intralabs, United Kingdom. The physical properties of these biopolymers as provided by the manufacturer are given in Table 3.2.

Table 3.2. Physical properties of biopolymers used (Intralabs, 2016a, 2016b).

| Properties                                   | Guar gum             | Xanthan Gum           | Remarks  |
|--|----------------------|-----------------------|--|
| Colour                                       | White                | Yellow white          |  |
| Viscosity (cP),<br>1% biopolymer<br>solution | 3500                 | 1200-1700             | Guar gum: Water solution<br>Xanthan gum: 1% Potassium<br>chloride solution |
| Particle Size                                | 97% passing 75<br>µm | 95% passing<br>180 µm |  |
| pH   | 6.5-7.5              | 6.0-8.0               |  |

### 3.2.3 Cement

In this thesis, the performance of biopolymer stabilised earthen construction materials are compared with unstabilised and cement stabilised materials. The cement used for stabilisation was CEM II type which conforms to the specifications set out in BS EN 197-1 (2011). The cement was procured from M/s Lafarge Cement UK Limited, United Kingdom.

## 3.3 Experimental programme

In this initial exploratory campaign to understand biopolymer stabilisation, the effect of biopolymers on plasticity, shrinkage and strength characteristics of the earthen construction material was studied. Subsequent sections present the testing methodology and results of this investigation.

### 3.3.1 Effect of biopolymers on plasticity and shrinkage properties of the soil mix

#### 3.3.1.1. Methodology

To understand the effect of biopolymers on plasticity and shrinkage properties of the soil, the portion of engineered soil mix passing through a 425 µm sieve was dry mixed thoroughly with biopolymers at varying contents of 0.5, 1.0, 2.0 and 3.0% by mass. Deionised water was then added to these mixtures and mixed thoroughly until a uniform stiff consistency was achieved. The wet mixtures were then stored in air-tight polythene bags to equilibrate for 24 hours. Atterberg limits namely liquid limit and plastic limits, and linear shrinkage of these equilibrated stabilised soil mixtures were determined as per British standard (BS 1377-2, 1990).

#### 3.3.1.2. Test results

##### a) Effect of biopolymers on plasticity properties of the soil mix

Figure 3.4 presents the effect of biopolymers on the Atterberg limits of the soil. The liquid and plastic limits of unamended soil mix were 36.2 % and 18.4 % respectively. The effect of biopolymers was different with respect to the biopolymer used. On addition of guar gum both

the liquid and plastic limits increased with the increase in biopolymer content. The increase in liquid limit was more significant than the plastic limit, indicating that the amount of water retained by guar gum is more significant at higher water contents. It was interesting to note that xanthan gum had a different effect on the liquid limit. For 0.5% of xanthan gum, the liquid limit was about 53.2% which was higher than that of the liquid limit of the unamended soil mix. After that, liquid limit decreased with increasing biopolymer content. The plastic limit of xanthan stabilised soil increased with the increase in biopolymer content. In order to understand how these variations would affect the plasticity characteristics of the soil, the plasticity indices with respective liquid limits for both the gums at each biopolymer content were plotted on a plasticity chart (Figure 3.5). As per BS 1377-2 (1990), the fines portion of the unamended soil mix was initially classified as Clay of intermediate compressibility i.e., CI. While on addition of guar gum, the classification of the fine portion changed to CH, indicating the behaviour of the biopolymer to be Clay with higher compressibility. In case of xanthan gum, classification changed to CH at lower biopolymer content, while at higher content the classification shifted back again to CI.

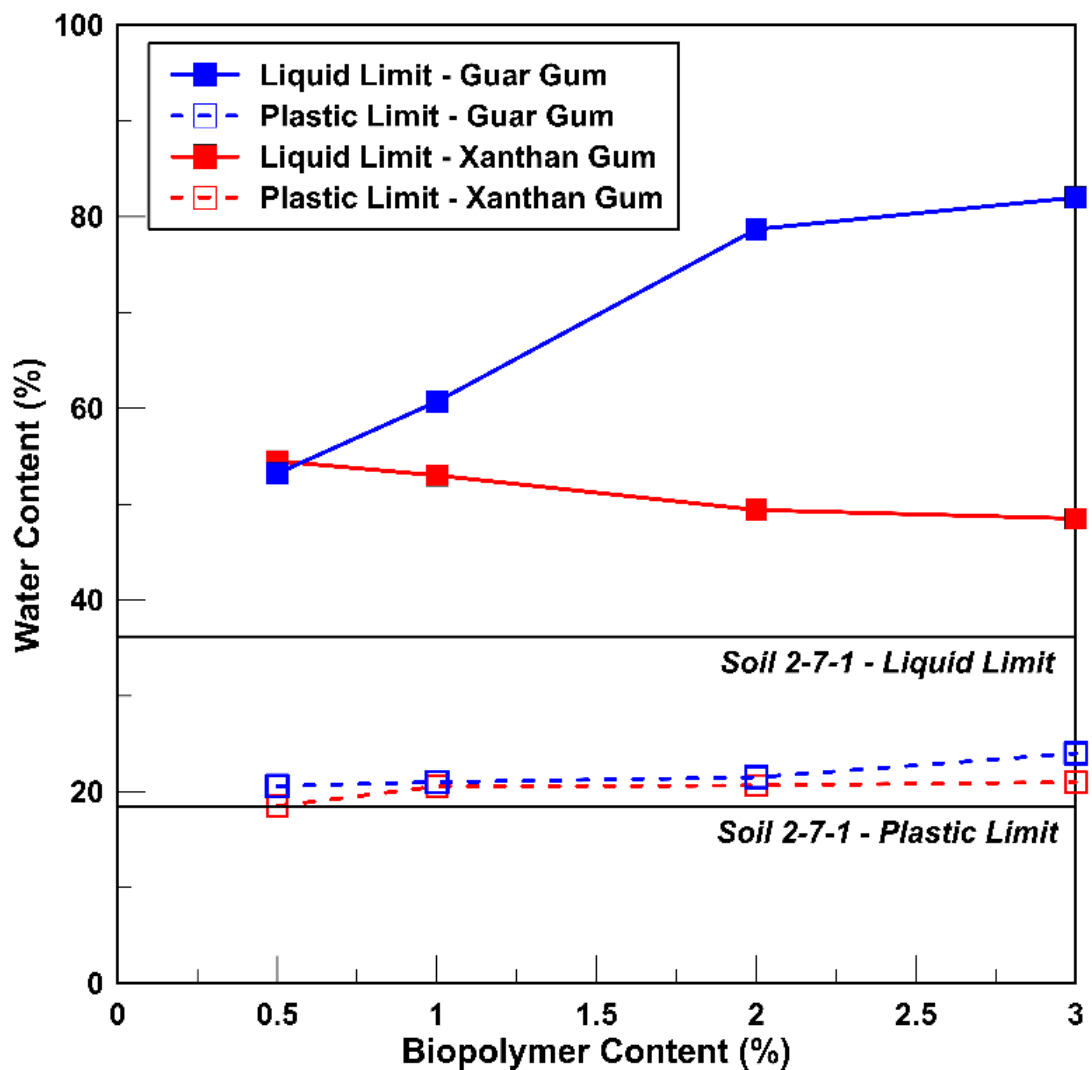

Figure 3.4. Effect of biopolymers on Atterberg limits of the soil.

b) Effect of biopolymers on linear shrinkage

Figure 3.6 presents the results of linear shrinkage tests. The linear shrinkage of the unamended soil mix was 5.0%. The linear shrinkage of the guar gum stabilised soil mix increased with biopolymer content. The linear shrinkage increased up to 12.5% at 3.0% biopolymer content indicating that the guar stabilised soil may be prone to high shrinkage effects. For the xanthan gum, on addition of 1.0% of the biopolymer, the linear shrinkage rose to 7.3%. While on subsequent increase of biopolymer content from 1.0%, the linear shrinkage of the soil reduced. For soil mixes stabilised with 3.0% xanthan gum, the linear shrinkage was about 5.3%, which was about the same as the value for the unamended soil mixture.

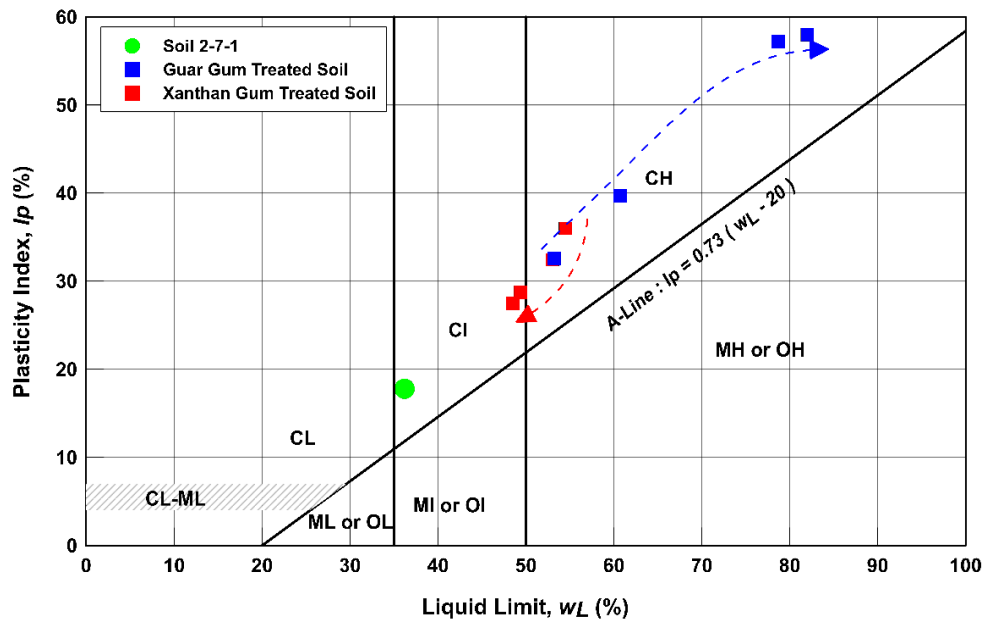

Figure 3.5. Effect of biopolymers on plasticity properties of the soil

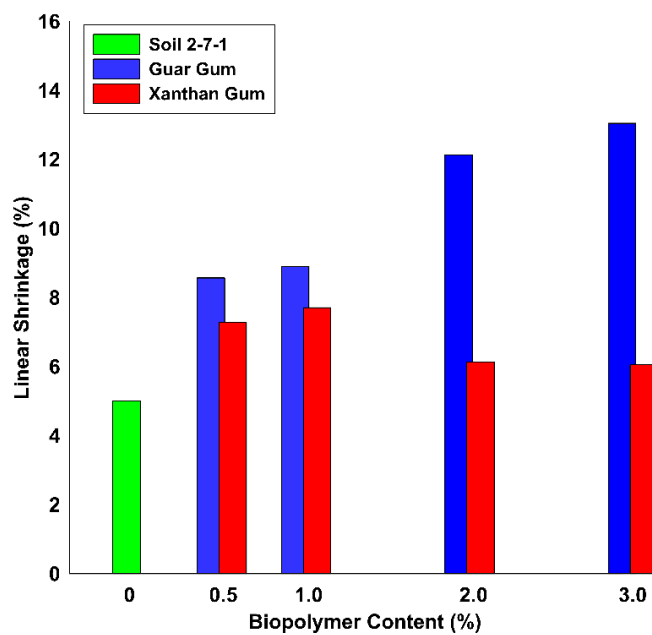

Figure 3.6. Effect of biopolymers on linear shrinkage of the soil

### c) Discussion on test results

Nugent et al.,(2009) reports that on addition of biopolymer, two important interactions occur within the soil-water matrix. Firstly, the hydroxyl groups of the biopolymer readily interact with pore water which increases its viscosity and tends to increase liquid limit. Secondly, the interaction between biopolymer chains and clay particles leads to soil agglomerations which reduces the overall surface area of soil particles. Thus, lower amounts of water are required to hydrate these agglomerations and this tends to lower the liquid limit. The combination of these two interactions determine the final liquid limit of the soil.

Being a neutral polysaccharide with large hydroxyl groups, guar gum essentially interacts with pore water and soil particles through formation of hydrogen bonds (Chudzikowski, 1971). Compared to soil agglomerations, interactions which increase the viscosity are more predominant for guar gum (Nugent et al., 2009) . Thus, the liquid limit of the soil proportionately increases with guar gum content. As a consequence, soil plasticity increases with higher guar gum content (Figure 3.5). Conversely, it would mean that on disappearance of these hydrogen bonds (i.e., drying of hydrogels) and with fewer soil agglomerations, guar gum stabilised soil would excessively shrink. This hypothesis may be confirmed from the higher linear shrinkage values of guar gum stabilised soil mixes (Figure 3.6).

In the case of xanthan gum, which is an anionic polysaccharide, the biopolymer readily interacts with net negative clay particles and forms many soil agglomerations bonded through ionic and hydrogen bonds (Katzbauer, 1998; Nugent et al., 2009; Chang et al., 2018). Nugent et al.,(2009) reports that after the initial peak, xanthan gum has a higher impact on soil agglomerations than its viscosity with increasing biopolymer content. Thus, higher concentrations of xanthan gum lead to greater soil agglomerations which reduce the overall surface area of the soil particles and thus reduces liquid limit (Figure 3.5). On drying, with better stabilisation, the xanthan gum stabilised soil mix may have better volumetric stability as noticed from linear shrinkage values (Figure 3.6).

### 3.3.2 Strength characteristics of biopolymer stabilised earthen construction materials

#### 3.3.2.1. Unconfined compressive strength of biopolymer stabilised earthen construction materials

The main objective of this investigation is to arrive at the biopolymer concentration which can provide comparable compressive strength to a cement stabilised earthen construction material. It was noted from the literature review that biopolymer concentration in the range of 1.0 – 3.0% of the dry soil mass is sufficient to achieve requisite strength and durability (Cabalar and Canakci, 2011; Chang et al., 2015; Qureshi et al., 2017), while higher concentrations of biopolymer affected workability (Chang et al., 2015). Hence, different biopolymer concentrations within this range were considered in this investigation (Table 3.3). For the cement stabilised

specimens, the stabiliser content was kept constant at 8.0% which conforms to the literature recommendations for stabilised earthen construction materials (Fitzmaurice, 1958; Houben and Guillaud, 1994; Walker and Stace, 1997; Bui et al., 2014).

Unconfined compression (UC) tests were performed on compacted cylindrical specimens of 38 mm diameter and 76 mm length. As this parametric study involves preparation of a large set of samples considering five varying stabiliser contents for both biopolymers along with unstabilised and cement stabilised specimens, manufacturing smaller cylindrical specimens was considered to be appropriate to understand the relative performances. Use of smaller cylindrical specimens is a quick and reliable approach which is commonly followed to assess the relative performances between materials of varying properties especially in geotechnical engineering (Reddy et al., 2007; Cristelo et al., 2012; Chan and Low, 2014). In addition, the test results were seen to potentially provide valuable insights to forecast other engineering properties of the stabilised earthen construction materials (Reddy and Jagadish, 1995).

Table 3.3. Different proportions of biopolymer used in this study.

| Biopolymer content by mass (%) | UCS tests | Tensile tests | Additional water added above OWC (%) |             |
|--------------------------------|-----------|---------------|--------------------------------------|-------------|
|                                |           |               | Guar gum                             | Xanthan gum |
| 0.5                            | √         | -             | 0.50                                 | 0.25        |
| 1.0                            | √         | √             | 1.00                                 | 0.50        |
| 1.5                            | √         | √             | 1.50                                 | 0.75        |
| 2.0                            | √         | √             | 2.00                                 | 1.00        |
| 2.5                            | -         | √             | 2.50                                 | 1.25        |
| 3.0                            | √         | √             | 3.00                                 | 1.50        |

### a) Sample preparation

In order to make the UC test specimens, the required quantities (mass basis) of the ingredients (sand, gravel, kaolin and biopolymer) were weighed and initially mixed in the dry condition. The biopolymer was pre-mixed with the dry ingredients of the soil-mixture in order to achieve better interactions with the soil mixture before the formation of hydrogels on later addition of water. The dry mixing enables the biopolymer to interact with the clay fraction more efficiently (Chang et al., 2015; Latifi et al., 2016), while for the sand portion, biopolymer coats the grain surfaces and increase the contact area of soil particles (Chang et al., 2015; Ayeldeen et al., 2016). After dry mixing, water equivalent to optimum water content obtained through the compaction test was added and mixed thoroughly. As biopolymer forms hydrogels when in contact with water, there was a necessity to add additional water in order to make the soil mix workable. The amount of additional water required varied with respect to the biopolymer used and values are given in Table 3.3. After adding the additional water and mixing thoroughly, the required bulk mix was weighed and introduced into the specimen mould in three layers (Figure 3.7). Each layer was statically compacted to achieve the desired density and the surfaces of the first and

### Chapter 3. Biopolymer Stabilisation

---

second layers were scratched in order to ensure proper bonding between layers. The compacting pressure to achieve the required density varied between 2.0-2.5 MPa. Finally, the compacted specimen was carefully removed from the mould. Following the preparation, samples were left to dry naturally in laboratory atmosphere (relative humidity (RH) of 50% and temperature of 21°C) and were then tested after 7 and 28 days. UCS test specimens of unamended and cement stabilised specimens were prepared similarly.

#### b) Testing Methodology

Three replicates of specimens were prepared for each biopolymer content and tested for unconfined compression as per the British standard (BS 1377-7, 1990) at designated curing periods. On the day of testing, mass and dimensions of the test specimens were recorded prior to testing. Test specimens were then set under the loading frame of a Shimadzu universal testing machine (Figure 3.8a). As the surface of the test specimens was level no capping was used for testing. The specimen was uniaxially loaded at a controlled displacement rate of 0.5 mm/min until failure. The displacement rate of 0.5 mm/min was chosen based on the previous testing conducted by Jaquin et al.,(2009) and Beckett et al.,(2017). Loads and displacements were automatically recorded by the TRAPEZIUM LITE X Software. After the completion of the test, some portion of the soil from the specimen was collected to measure the water contents, while another portion was collected to measure total suction using the WP4C dewpoint potentiometer (Decagon Devices, 2007).



(a)



(b)

Figure 3.7. Setup for preparation of UCS test specimens (a) Mould, (b) Static compactor

## Chapter 3. Biopolymer Stabilisation

---

As the test specimens were left to dry naturally under relative humidity (RH) of 50% and temperature of 21°C, it can be expected that these conditions impose high suction on the test specimens. In order to have a measurement at this high suction regime, a dew point potentiometer was used to measure the total suction (Figure 3.8b). The dew point potentiometer works on the principle of equilibrating the sample with the ambient conditions within the sample chamber. The dew point potentiometer used here has a working range of 1-300 MPa and enables suction measurement of soils having very low water contents, e.g. earthen construction materials. Dewpoint potentiometer can obtain suction measurements through three different reading modes, i.e. precise, fast and continuous modes (Decagon Devices, 2007). In precise mode, the measurements are obtained until the successive suction readings are within the preset tolerance level of 0.03MPa. In fast mode, the suction measurement happens only once, however, the readings are less precise. In continuous mode, the measurements are obtained continuously for as long as the specimen is kept in the sample chamber. In this investigation, precise mode was chosen to obtain suction measurements. In general, each sample took about 15-30 min to equilibrate within the sample chamber before the suction reading was displayed. The final suction readings reported herein are mean of the three replicates.



(a)



(b)

Figure 3.8. Testing of UCS test specimens (a) universal testing machine, (b) dewpoint potentiometer

### c) Test results

Axial stress/strain plots recorded during the compressive tests are shown in Figure 3.9. The initial low stiffness at low axial strains are due to sample bedding in and the key conclusions are drawn from the results at > 0.5% strain. After 7 days of curing, for both guar and xanthan gum stabilised specimens, there is an appreciable difference in the modulus between different

concentrations, with higher concentrations leading to higher modulus. At 28 days curing, however, modulus had peaked at 1.5% of biopolymer content (Figure 3.10 and 3.11). These variations of the modulus provide evidence of the change of state of the hydrogel products formed by the biopolymers, which is discussed in more detail below.

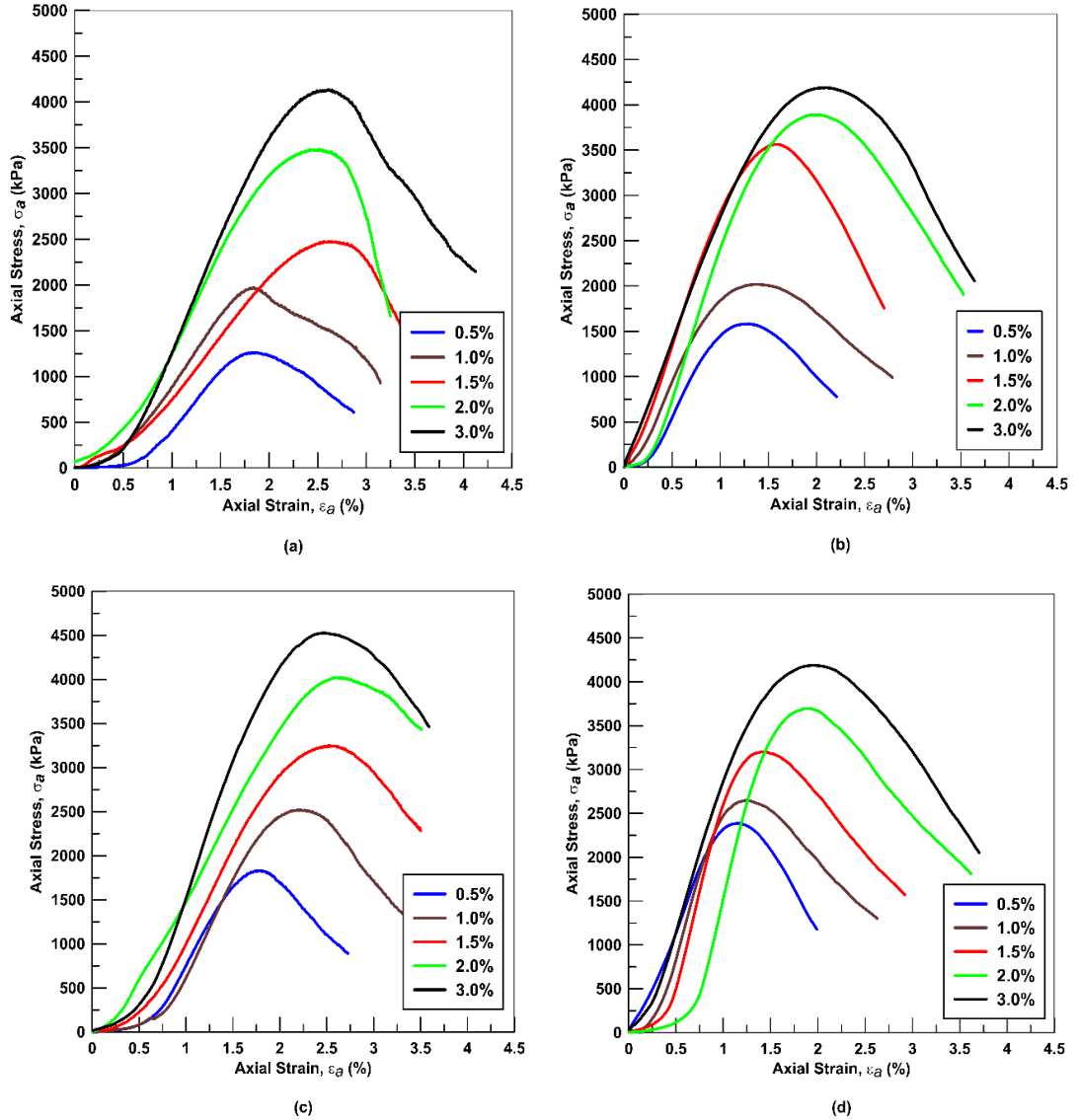

Figure 3.9. Stress–strain behaviour in UC tests (for each %stabiliser only one test among three replicates is shown): (a) guar gum, 7 days, (b) guar gum, 28 days, (c) xanthan gum, 7 days, (d) xanthan gum, 28 days

For each sample, the peak strength was derived from the peak stress obtained from the stress-strain plot, while the slope of the stress-strain curve in the elastic region was considered as the soil modulus. UC peak strength and soil modulus are plotted against % stabiliser for both biopolymers in Figures 3.10 and 3.11 respectively. Entire test results are presented in Appendix. It can be seen that an addition of 2.0% guar gum provides soil with compressive strength higher than the cement-stabilised sample: approximately 30% higher after 7 days and 35% after 28

days. After 7 days, xanthan gum at 1.5% produces approximately the same strength as the cement stabilised specimen and, at 2%, the strength becomes approximately 50% higher than the cement stabilised specimens. This is an encouraging finding confirming the potential of biopolymers as stabilisers. For the range of percentage stabiliser additions, both plots show increasing strength, with no optimum treatment days concentration reached within the range tested, although all stabilised samples improve on the unamended soil. However, xanthan gum stabilised specimens tested at 28 days showed reductions in strength compared to the 7-day specimens. Given the variation in strength behaviour between stabiliser concentrations and curing periods discussed above the primary mechanisms controlling strength would appear to be different to that driving stiffness.

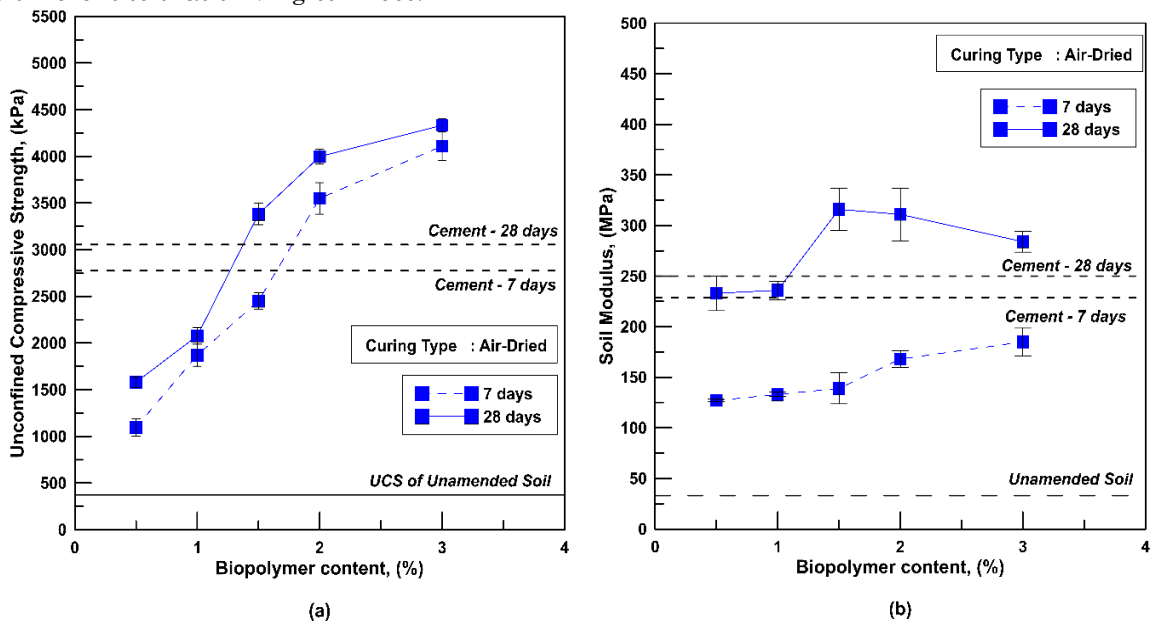

Figure. 3.10. UC test results for guar gum (average values of peak strength based on three replicates), (a) peak strength, (b) soil modulus

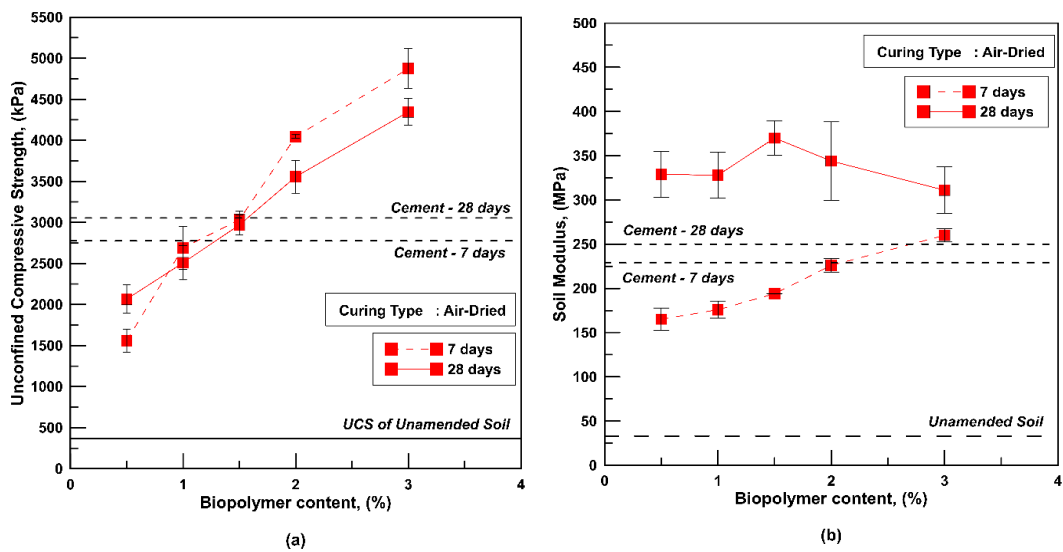

Figure. 3.11. UC test results for xanthan gum (average values of peak strength based on three replicates), (a) peak strength, (b) soil modulus

### 3.3.2.2. Tensile strength of biopolymer stabilised earthen construction materials

Bui et al.,(2014) noted that unlike other characteristics of an earthen construction material, studies of tensile behaviour are limited. In fact, tensile strength of earthen construction material is considered to be very low and its direct determination is often neglected. However, tensile strength of the soil is a key indicator of its cracking propensity, as it depends on soil suction and water content (Towner, 1987). Furthermore, tensile strength is necessary to evaluate the seismic performance of an earthen building (Gomes et al., 2011; Araki et al., 2016).

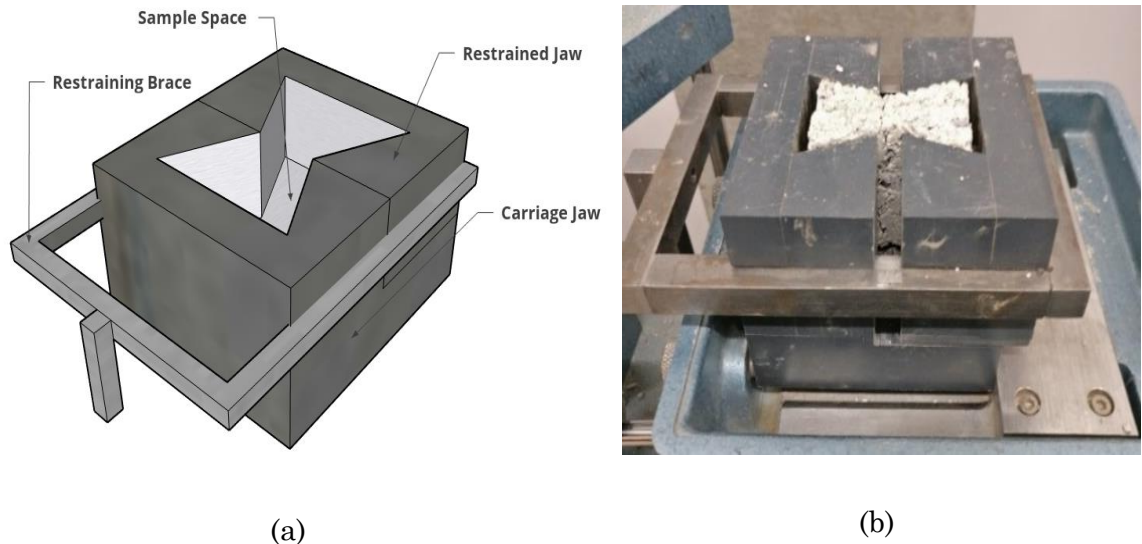

Figure 3.12. Direct tension tests a) NDTT illustration (b) Test-setup

Though being an important parameter, determination of an earthen material's tensile strength experimentally is a difficult task. The methods to determine tensile strength are different for saturated and unsaturated soils as these two classes of soils require different equipment and testing procedures (Nearing et al., 2010). Tensile tests are further classified into direct or indirect tension tests. Direct tension tests apply an axial tensile load, while indirect tests (such as the Brazilian test) exploit the application of compressive loading such that the specimen fails in tension (Stirling et al., 2015). Determination of tensile strength either through direct or indirect approaches has its own advantages and limitations. Recently, Stirling et al., (2015) developed a new method to determine the tensile strength of soils having relatively low saturation. The method known as the Newcastle Direct Tensile Test (NDTT) requires simple reversible modification of existing direct shear apparatus. The tensile strength determined through this new method compares well with the strength obtained from the well-known Brazilian method (an indirect tension test).

#### a) Sample preparation

To determine the tensile strength of biopolymer stabilised earthen construction materials, similar testing arrangements as outlined by Stirling et al.,(2015) was used. Based on UC test

results, it was noted that about 1.5% of biopolymer content was sufficient to obtain a comparable strength of cement stabilised earthen material. Hence, for determining tensile strength, biopolymer contents higher than 1.5% were chosen (Table 3.3). The tensile specimens are manufactured in the shape of a bow-tie (Figure 3.12b) and preparation procedure of these specimens are similar to that of UC test specimens, i.e. compacting the soil in three layers in a sample mould to achieve the required dry density. The specimen possesses a mirrored isosceles trapezium plan cross-section (27 x 16 x 46 mm), this constraint, i.e. reduced cross-sectional area induces failure at the neck of the specimen. Biopolymer stabilised tensile specimens were cured under similar conditions as that of UC test specimens and tested after 7 and 28 days. Tensile strengths of unamended and cement stabilised specimens were also obtained similarly.

On the day of testing, mass and dimension of the cured specimen was noted. The test specimen was introduced into the modified 60mm square direct shear testing rig. The sample was secured between the loading jaws of the modified rig (Figure 3.12). By propelling the motor of the testing rig, the carriage jaw moves away from the restrained jaw uniaxially which induces tension on the sample. The rate of deformation can be controlled similarly to a direct shear test, in this case it was maintained at 0.5 mm/min. The loading on the sample continued until obvious failure. Load and displacement values were recorded manually. For all the specimens tested, the testing duration was about 8 -10 min. After the test was completed, some portion of the tested specimen was collected to measure the water contents, while another portion was collected to measure total suction using the WP4C dewpoint potentiometer (Decagon Devices, 2015).

### b) Test results

Stress/strain plots recorded during the tensile tests are shown in Figure 3.13. After 7 days of curing, for both guar and xanthan gum stabilised specimens, there is a fairly linear relationship between stress and strain for both. All specimens softened after reaching the peak stress. It was observed that beyond peak stress, the specimens started to fail across the neck of the specimen. After 28 days, the observed peak strengths and stiffness for all concentrations of guar gum specimens were less than the 7 day cured specimens. In the case of xanthan gum stabilised specimens, all concentrations led to higher strength and stiffness than 7 day cured specimens. Furthermore, after reaching the peak strength specimens failed immediately with well-defined brittle failure without any signs of softening.

Peak tensile strength is plotted against stabiliser concentration in Figure 3.15 indicating a clear relationship between stabiliser concentration and tensile strength. The error bars show the greater variation for these tests which can be explained by the different modes of failure. Tensile strength will be critically affected by the presence and nature of microcracking which will vary between samples and be difficult to predict or control. Shear failure in the UC tests show much less scatter as the resistance to failure is more distributed over a surface. Unlike the UC results, the tensile strength of the guar gum samples reduced with time whereas the

xanthan gum samples increased with time. At 7 days, all concentrations of biopolymer lead to higher tensile strengths than unamended soil, but lower than the cement stabilised soil. At 28 days, the strength of the 2% xanthan gum stabilised soil exceeds the cement stabilised soil by 38%. Differences in the relative performances of cement and biopolymer stabilised samples when tested in tension, as opposed to compression, suggests that the stabilising mechanisms through which compressive and tensile resistance is mobilised within the specimens are different.

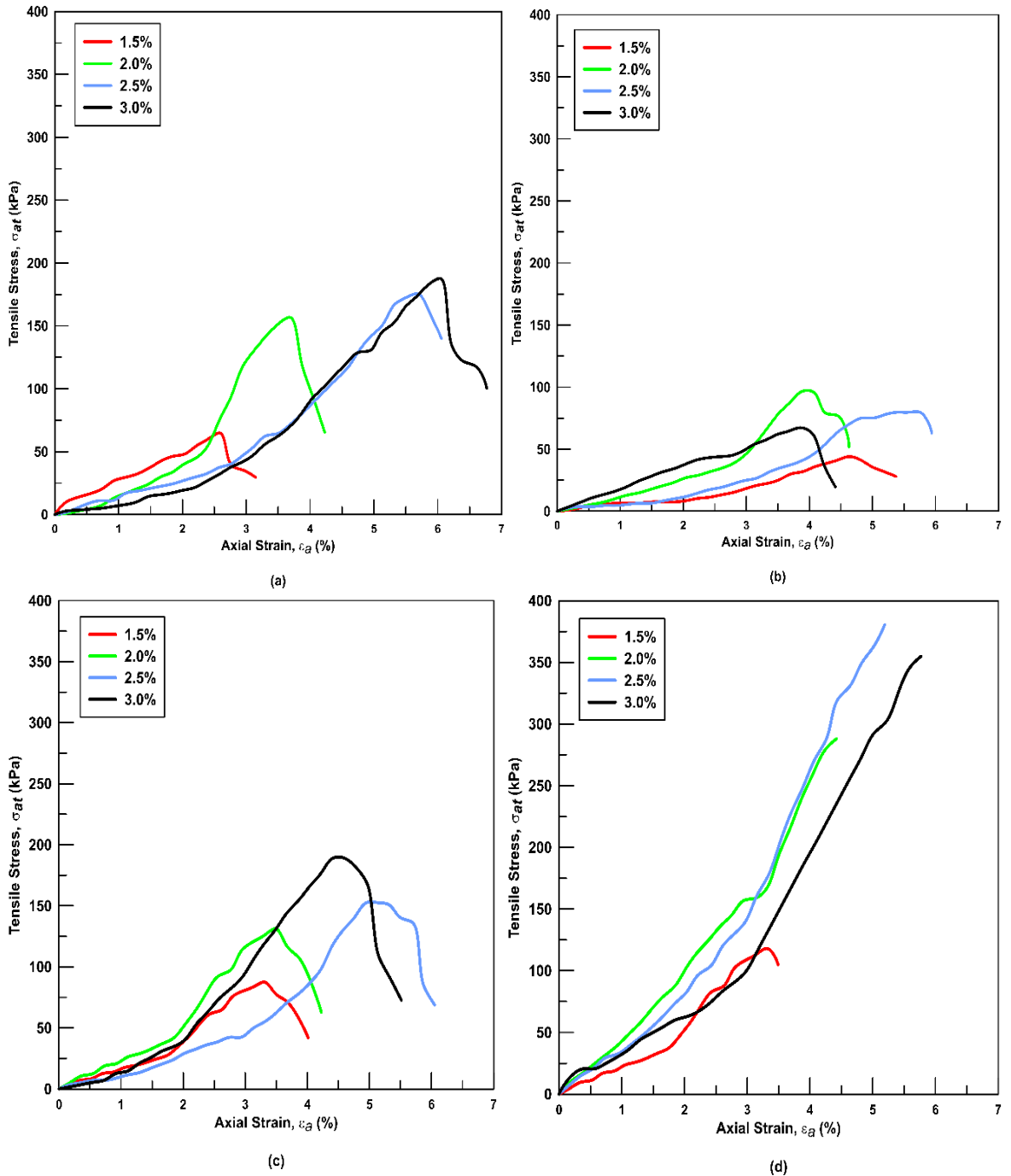

Figure 3.13. Stress–strain behaviour in Tensile tests (for each %stabiliser only one test among three replicates is shown): (a) guar gum, 7 days, (b) guar gum, 28 days, (c) xanthan gum, 7 days, (d) xanthan gum, 28 days



Figure 3.14. Failure patterns for 28-day tensile specimens for a) guar gum (b) xanthan gum

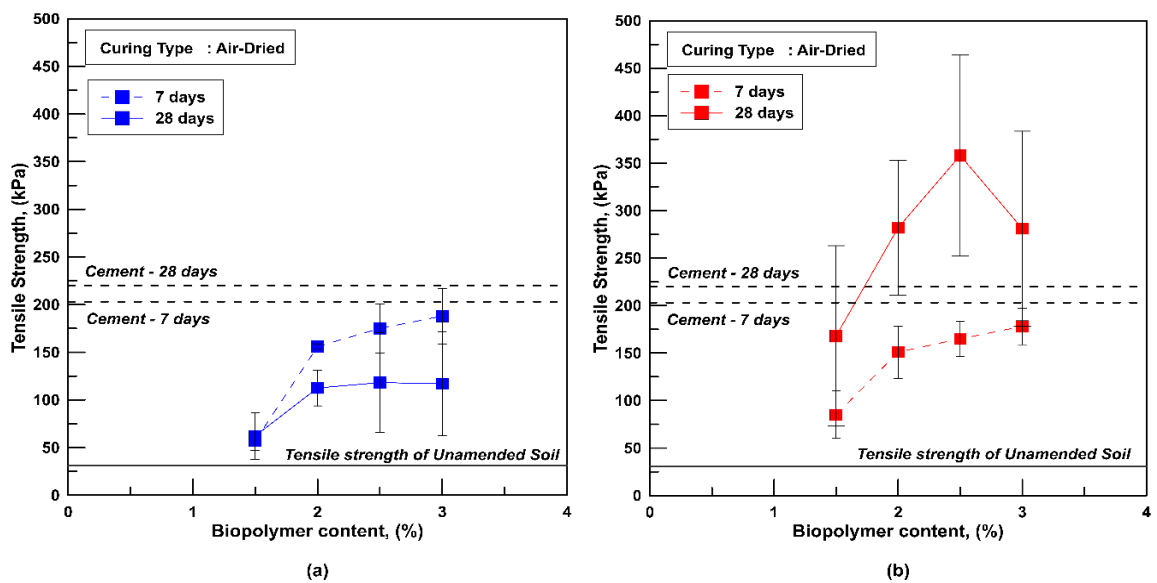

Figure. 3.15. Tensile test results (average values of tensile strength based on three replicates), (a) guar gum, (b) xanthan gum

### 3.3.2.3. Discussion on strength test results

#### a) Effect of suction and hydrogel formation on strength characteristics

As noted in Jaquin et al.,(2009) and Bui et al., (2014), a significant component of the strength of unstabilised soil-based construction materials can be linked to the suction present due to the very low in-situ water contents and presence of fine soil fractions. Lakshmikantha et al., (2012) reports tensile strength in soils to be essentially a product of soil cohesion and soil suction. Further, Zhao (2014) and Cao et al., (2017) using Tempe cell measured soil water characteristic curves (SWCCs) for poorly graded sand initially saturated with water and biopolymer solutions. It was noted that higher matric suction was needed to desaturate sand treated with xanthan gum solution at 2g/L concentration, indicating that addition of biopolymer will have an effect on the suction present in a stabilised soil. It was therefore instructive to measure suction for the

materials tested here to understand the effect of biopolymer addition on suction and potentially strength.

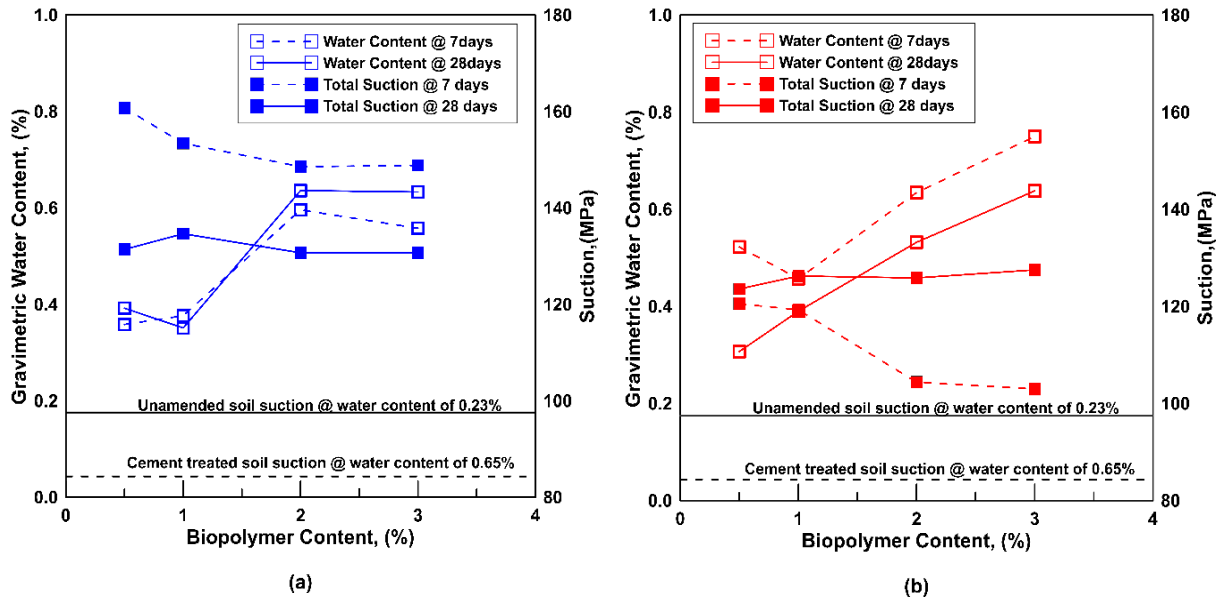

Figure. 3.16. Suction and water content values after UC tests (a) guar gum, (b) xanthan gum

Figure 3.16 shows suction and water content data recorded immediately after UC strength testing. Similar relations between suction and water content were noted for tensile test specimens. Some observations are as follows:

- All biopolymer stabilised samples exhibit higher suctions than the unamended and cement stabilised specimens indicating a contribution from osmotic suction from biopolymer products (indeed suctions are evident in samples of plain hydrated biopolymer confirming this). The effect is not dependent on % stabiliser at 28 days but at 7 days there is a variation indicating that as the hydrogels change state, their contribution to suction varies.
- At 28 days, the water content of guar gum stabilised samples was higher than 7 days, while for xanthan stabilised samples it was lower. This variation may be due to their interaction with surrounding atmosphere. As noted by Kocherbitov et al., (2010), the vapour sorption/diffusion of a biopolymer is dependent on its state, temperature and humidity. Hence, by the end of 28 days, guar gum stabilises through water absorption from the atmosphere, while xanthan gum, uses as much free water as it needs, with the remainder of the water evaporating.
- At 7 days, the suction measured in the unamended samples corresponds to the value calculated using Kelvin's equation, given the average RH and temperature in the laboratory. For the amended samples, however, suction equilibrates at a higher level, between 125 and 135 MPa, further confirming osmotic suction contributions from the presence of the biopolymer products.

- Water contents increase with % stabiliser throughout which is linked to the additional water required to achieve workable mixes. As % stabiliser of biopolymer more hydrogels are formed with which it retains more water in the soil mix.
- After 7 days, high suctions are linked to low water contents for both gums indicating a more significant contribution to suction from pore water than at 28 days.

However, when the suction results are reviewed in parallel with the UC strength data (Figure 3.8 and 3.9) clear conflicts are evident. For the guar gum samples, suctions are seen to reduce between 7 and 28 days, while compressive strengths increase. Equally, for the xanthan gum samples, suctions increase while UC strengths decrease. Changes in UC strength must therefore be explained through additional mechanisms besides suction induced capillary bonding. Conversely, suction changes shown in Figure 3.11 correspond well with changes in tensile strength of the biopolymer stabilised soils in that decreases in suction of guar gum samples after 28 days correspond to lower strengths, and increases in suction in xanthan gum samples correspond to higher strengths. The higher suctions and strengths of the biopolymer stabilised specimens compared to the unamended specimens suggest that the strength gains are caused by a combination of suction and hydrogel bonding. The nature of the bonding of these hydrogels with soil particles depends on the biopolymer type.

Guar gum, being a neutrally charged polysaccharide with large hydroxyl groups (Chudzikowski, 1971), forms a network of hydrogels between soil particles and free water via hydrogen bonds (Chen et al., 2013). At 7 days, these hydrogels (predominantly being in a rubbery state) may contribute to matric suction and hence the stabiliser content contributes to the measured suction (Figure 3.11). Thereby, the combination of suction and hydrogels contribute to the observed higher compressive strength of the soil. Tensile strength is also believed to be driven by a combination of suction and hydrogel bonding. However, as hydrogels are more elastic and weaker than cement bonds in tension, the tensile strengths are lower than the cement stabilised specimens. Once the hydrogels transform to a glassy state, the suctions tend to reduce and reach constant values irrespective of stabiliser content (Figure. 3.11). However, the increase in compressive strength and soil modulus may be attributed to the network of hydrogels now in a glassy state connecting the soil particles. Being a weaker chemical bond, the hydrogen bonds may not contribute to tensile strength with aging.

Xanthan gum is an anionic polysaccharide (Katzbauer, 1998; Garcia-Ochoa et al., 2000) and the gum may interact with cations of the clay portion of the soil mix to form chemically stronger ionic bonds in addition to hydrogen bonds (Chang et al., 2015a). This combination of ionic and hydrogen bonds will result in better aggregation of the soil particles (Chen et al., 2013). Similar to guar gum, at 7 days, the combination of suction and hydrogel bonding contributes to both compressive and tensile behaviour of xanthan gum stabilised soils. Whilst there is a slight decrease in compressive strength at 28 days, ionic bonding and transformation of hydrogels is reflected in higher suction which in turn results in higher soil modulus (Figure. 3.10) and increases in tensile strength with time for xanthan gum stabilised soils.

b) Comparison of unconfined compressive and tensile strengths

Though tensile strength of earthen construction material is a key indicator in understanding its cracking propensity and seismic behaviour, characterisation of these materials is rarely done on the basis of tensile strength (perhaps due to perceived difficulties in tensile testing). Where it is considered, the tensile strength is suggested to be about 10% of the unconfined compressive strength of the material (NZS 4297, 1998). Reported tensile to unconfined compressive strength ratio values suggest that soil gradation and stabilisation effect have an influence on this ratio. Araki et al., (2016) studied the effect of both direct and indirect tensile tests on unstabilised rammed earth materials. It was reported that the tensile strengths were in the range of 5.0 – 12.5% of the corresponding unconfined compressive strengths at the same water content range. Liu and Tong (2017) studied engineering properties of unstabilised rammed earth mixtures with varying clay contents. It was reported that with the increase in clay content of the soil mixture, the tensile to unconfined compressive strength ratio tended to reduce. The strength ratios were in the range of 0.17-0.23. Hallal et al., (2018) reports that the compressive strength of earthen material increased proportionately with cement content, while the improvement in tensile strength was not significant. The reported tensile to unconfined compressive strength ratio reduced from 0.12 for the unstabilised earthen mixture to 0.08 for the stabilised earthen material.

Table 3.4. Tensile to unconfined compressive strength ratios

| Series             | UCS (MPa) | Tensile (MPa) | Tensile to UCS ratio |
|--------------------|-----------|---------------|----------------------|
| Soil 2-7-1         | 0.37      | 0.03          | 0.08                 |
| Cement – 8.0%      | 3.05      | 0.22          | 0.06                 |
| Guar gum – 2.0%    | 3.99      | 0.11          | 0.02                 |
| Xanthan gum – 2.0% | 3.55      | 0.29          | 0.08                 |

From the UC and tensile tests conducted, it can be observed that about 1.5-2.0% of biopolymer content was sufficient to achieve comparable compressive strength to 8% cement stabilised specimens. In case of tensile tests, even at higher concentrations of guar gum, the tensile strengths could not match the strengths of cement stabilised specimens. For xanthan gum stabilised specimens, at about 2.0% of the biopolymer content, the tensile strengths surpassed those of cement stabilised specimens. At this biopolymer content, a comparison of unconfined compressive to tensile strength ratio has been made for biopolymer stabilised specimens unamended and cement stabilised specimens in Table 3.4. It can be observed from the table that all soil mixes have lesser tensile to unconfined compressive strength ratio as suggested by NZS 4297 (1998). Comparing soil mixes, it can be noted that the unamended soil mix has a ratio of 0.08. Addition of cement and guar gum reduced this ratio, with guar gum having the least value. For xanthan gum stabilised specimens, the ratio was identical to the

unamended soil mix, indicating that the addition of xanthan gum has proportional stabilising effects on both compressive and tensile strengths.

### 3.3.3 Synergistic behaviour of biopolymers

It has been reported in the literature that xanthan gum interacts synergistically with galactomannans like guar gum and improves stabilisation (Katzbauer, 1998; Casas et al., 2000). Casas et al., (2000) observed that combinations of xanthan and guar gum solutions showed a higher viscosity than that occurring in each separate gum. This synergistic interaction was further affected by the gum ratio in the mixture and dissolution temperature of both gums. There are very few reported studies which have attempted to utilise these biopolymers in synergy to stabilise soil. Chen (2014) evaluated the dust resistance of mine tailings stabilised with guar gum, xanthan gum and combination of these gums in a wind tunnel test. It was noted that the rate of erosion for synergistically stabilised mine tailing specimens were lesser than the individually stabilised specimens. At the end of 10 cycles of exposure to wind, the observed loss of mass for all biopolymer stabilised mine tailings specimens was lesser than the unstabilised specimens.

To explore the potential of biopolymer synergy, the engineered soil mix was stabilised with three combinations of guar and xanthan gum (Table 3.5). Based on the unconfined compression and tensile test results, it was decided that the biopolymer content at 2.0% of dry soil mass would be sufficient to achieve adequate strengths and hence combined stabiliser content for these combinations was maintained at this level. For these soil mixes, Atterberg limits, linear shrinkage and strength tests were performed following the experimental procedures as described in previous sections.

Table 3.5. Synergistic combinations of biopolymer used in this study.

| Combination | Guar gum (%) | Xanthan gum (%) | Additional water added above OWC, (%) |
|-------------|--------------|-----------------|---------------------------------------|
| 1.          | 1.5          | 0.5             | 1.75                                  |
| 2           | 1.0          | 1.0             | 1.50                                  |
| 3           | 0.5          | 1.5             | 1.25                                  |

#### 3.3.3.1. Plasticity and shrinkage characteristics

Table 3.6 tabulates the Atterberg limits and linear shrinkage values of synergistically stabilised soil mixes. The results are compared with unamended and individually stabilised biopolymer soil mixes where the stabiliser content was maintained at 2.0%. It can be observed from the tabulated results that, similar to individually stabilised soil mixes, the synergistically stabilised soil mixtures have higher liquid and plastic limits than the unamended soil mix. Within these combinations, lower liquid limit was achieved for the combination having the highest xanthan gum content. The plastic limits of the three combinations were in a similar range and higher

than those of individually stabilised soil mixes. To understand the effect of stabilisation on soil plasticity, liquid limit and plasticity indices for all soil mixes were plotted on plasticity chart (Figure 3.17). It can be noted from the plasticity chart, that the classification of the fine portion for all these combinations changed from the original CI to CH. Linear shrinkage test results indicate that the combination having highest xanthan gum achieved a lower linear shrinkage value. The test results suggest that there is no drastic improvement in plasticity or shrinkage properties of synergistically stabilised soil mixes, however, it can be noted that combination of xanthan and guar gum performs better than the soil mix stabilised with only guar gum.

Table 3.6. Atterberg limits and linear shrinkage values.

| Combination             | Liquid limit (%) | Plastic Limit (%) | Plasticity Index (%) | Linear Shrinkage (%) |
|-------------------------|------------------|-------------------|----------------------|----------------------|
| Soil 2-7-1              | 36.2             | 18.4              | 17.8                 | 5.0                  |
| Guar gum (GG) – 2.0%    | 78.7             | 21.5              | 57.2                 | 12.1                 |
| Xanthan gum (XG) – 2.0% | 49.4             | 20.7              | 28.7                 | 6.0                  |
| 1.5% GG + 0.5% XG       | 80.0             | 23.4              | 56.6                 | 11.6                 |
| 1.0% GG + 1.0% XG       | 72.1             | 23.2              | 48.9                 | 8.4                  |
| 0.5% GG + 1.5% XG       | 53.0             | 23.3              | 29.7                 | 6.0                  |

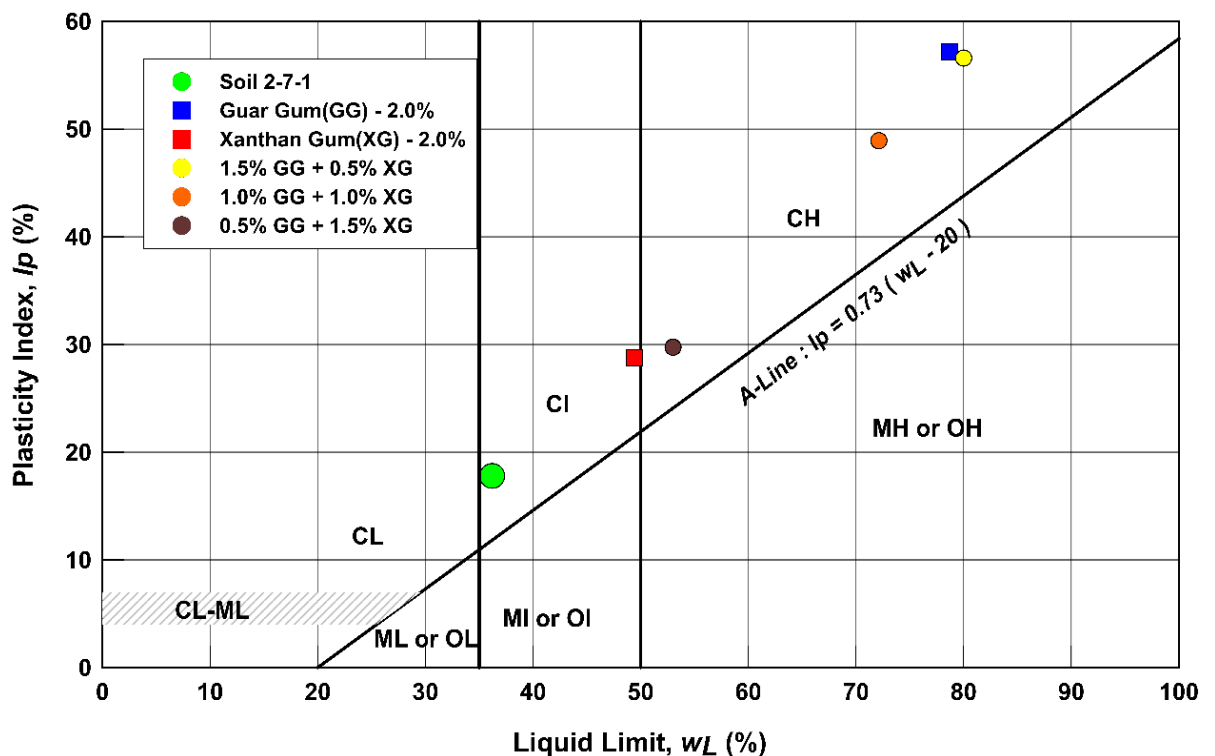

Figure 3.17. Effect of synergistic behaviour of biopolymers on plasticity properties of the soil

3.3.3.2. Strength characteristics

Compressive and tensile test specimens for the synergistic combinations mentioned in Table 3.11 were prepared and tested in a similar procedure as described in section 3.3.2.1. During sample preparation, the additional water above OWC which is needed to make soil workable varied proportionally with the gum ratios considered. The additional water required for these combinations are tabulated in Table 3.9. Strength tests were performed at 7 and 28 days and results were compared with the strengths of individually stabilised and cement stabilised specimens (Figure 3.18). It can be noted that both compressive and tensile strengths of all biopolymer combinations are higher than those of the cement stabilised specimens. Amongst biopolymer combinations, peak compressive strengths of synergistically stabilised specimens were in a similar range to those of individually stabilised specimens at 7 and 28 days. At 7 days, all synergistic combinations had soil modulus than individually stabilised specimens, however, modulus values at 28 days were similar. The synergistic behaviour of biopolymers is more noticeable in tensile strengths. After 28 days, it can be noticed that, even small proportion of xanthan gum (i.e. 0.5%) in combination with guar gum ensured higher tensile strengths than 2.0% guar gum stabilised specimens. Furthermore, the other two combinations which have higher concentrations of xanthan gum achieved higher tensile strengths than 8.0% cement stabilised specimens.

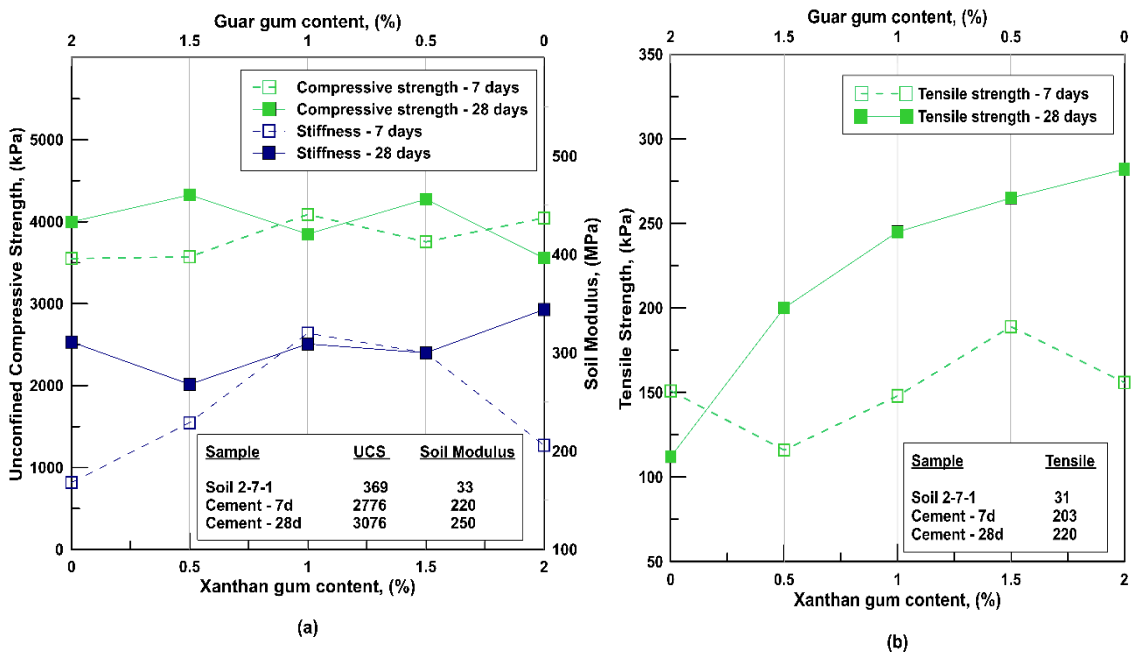

Figure 3.18. Comparison of strength characteristics of synergistic combinations (a) UC peak strength and stiffness, (b) peak tensile strength

It is important to note here that currently there are no reported detailed studies which report environmental sustainability of using biopolymers as soil stabilisers. It is known that xanthan gum sequesters CO<sub>2</sub> during production (Krishna Leela and Sharma, 2000; Chang et al.,

2016) in contrast to cement which emits carbon and this fact may prompt one to classify these biopolymers as sustainable. However, the energy required in the production of these gums may be much greater than for an equivalent amount of cement (Lo et al., 1997). Full Life Cycle Assessment (which is currently not available) is needed to provide firm guidance here. Research findings from this investigation which highlights the potential of biopolymer synergy may be useful from a mechanical point of view, if use of biopolymers in combination is found to be more environmentally sustainable.

### 3.3.4 Macrostructural investigation through X-Ray computed tomography

Soil is a three-phase material consisting of solids (soil particles), fluid (pore water) and gas (air voids). In a soil element, these constituents form a complex internal architecture which is diverse over a range of scales (-mm to - $\mu\text{m}$  scale). For this reason, soil is often considered to be 'the most complex material in the planet' (Young and Crawford, 2004). From a soil mechanics perspective, structure plays a vital role in contributing to the mechanical and hydraulic properties of the soil. Soil structure includes shape, size, distribution and arrangement of soil particles and pore space within the soil. Historically, to understand the soil structure, soil specimens were impregnated with a hardening agent such as resin which would replace air and water from pore spaces. Once the soil specimen was hardened, it was cut into thin slices, polished and analysed (Jang et al., 1999). However, this kind of procedures are time consuming and potentially alter the soil properties. As an alternative, many non-destructive testing techniques have evolved which determine the physical condition of soil specimen without causing any major damage. One such technique is Computed tomography (CT) which creates 2D or 3D reconstructions of internal features of objects (Roscoe, 1970; Wellington and Vinegar, 1987).

#### 3.3.4.1. X-Ray computed tomography

X-Ray Computed tomography (XRCT) is an improved version of CT which has increased scanning resolution: currently XRCT devices can achieve scans with maximum resolutions of roughly  $0.05\ \mu\text{m}$  and resolutions of  $10\ \mu\text{m}$  for objects that are a few millimetres across (Rigby et al., 2011). Similar to CT scanning, XRCT enables one to visualise the object in 2D and 3D based on the principle of attenuation of electromagnetic waves by different materials (Helliwell et al., 2013). A typical XRCT setup is shown in Figure 3.19 and consists of an X-ray source, sample manipulation stage and a detector. The source of an electromagnetic wave may be a conventional X-ray tube or synchrotron light. The sample is mounted on a sample stage which can rotate such that X-ray images can be obtained at incremental angular positions. The detector is either an X-ray detector or a scintillator screen followed by a CCD camera.

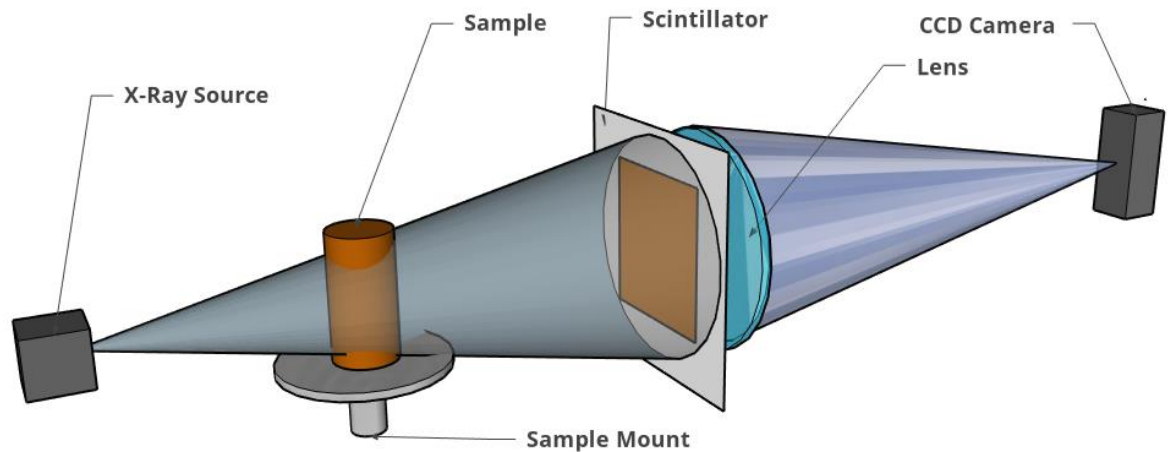

Figure 3.19. Typical X-RCT machine setup.

In an X-ray tube, electrons (negatively charged atomic particles) are made to travel in vacuum from cathode to anode. When this focused electron beam hit the anode, X-rays are generated. The generated X-ray beam upon leaving the tube is then shaped into a cone as it passes through a circular aperture. The emitted X-rays from the source then pass through the sample securely placed on sample stage and are then progressively attenuated (i.e. a loss of energy as the ray passes through the sample) by absorption and scattering due to the sample. Due to the attenuation, the sample becomes a secondary source of X-rays and electrons through atomic interactions (Mooney et al., 2012). The physical characteristics of the sample determine whether they absorb or scatter a photon (free electron) which determines the extent of attenuation. The attenuated X-rays are then picked up by the detector which produces a 2D grey-scale image of the sample at the given orientation. By rotating the sample in small increments on the sample stage, a series of grey-scale attenuated images or 2D projections are captured. which are then used to perform mathematical reconstruction of the sample. Through mathematical filtered back-projection algorithms cross sectional 2D image slices are generated from attenuated images. Each of these tomographic 'slices' consists of discrete units known as pixels. When these slices are stacked one above the other, on 3D tomography the discrete unit is known as voxels (i.e. volume pixels) which represent the spatial resolution of the scan (Helliwell et al., 2013). The reconstructed 3D model of the scanned sample can be used for visual inspection and quantitative analysis.

A processed image from XRCT scan consists of soil particles and pore spaces (both water and air-filled). Based on the attenuation density which is dependent on the material property, the grey values in the image are ordered. The soil particles being denser have the brightest voxels (highly attenuating), while pore spaces, being less denser are shown as darker voxels (low attenuation) (Helliwell et al., 2013). A typical XRCT scan image consisting of different soil components is presented in Figure 3.20.

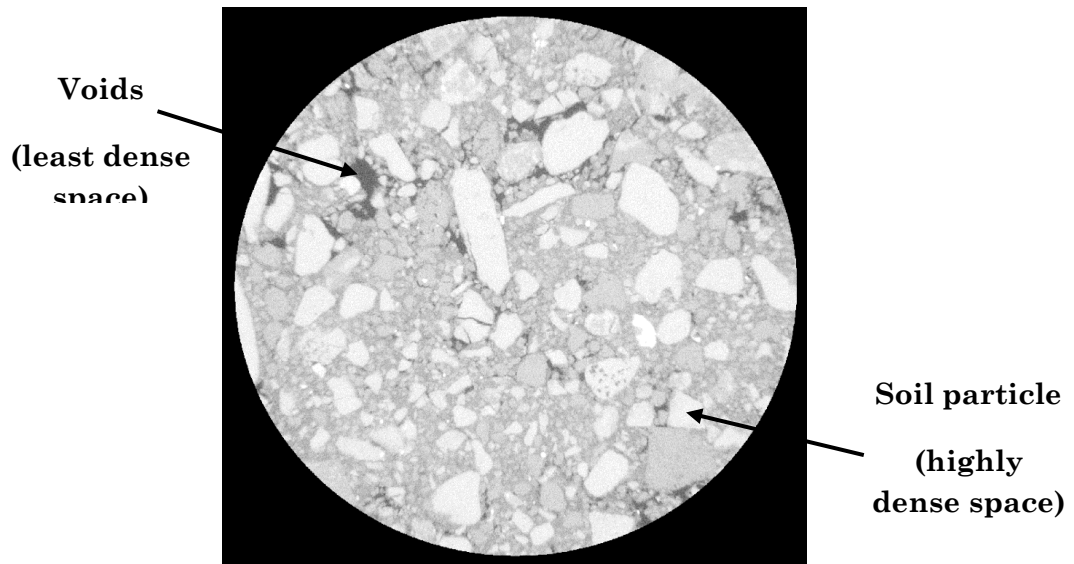

Figure 3.20. Typical XRCT scan of soil.

#### 3.3.4.2. Sample preparation and scanning

As noted from the strength tests, the biopolymer stabilisation is achieved through combination of soil suction and hydrogels. These “*hydrogels*” can be defined as chemically or physically cross-linked polymers having a hydrophilic structure which allows them to absorb water into their three-dimensional porous structure and to swell without dissolving (Brax et al., 2017). From this definition, it appears that the hydrogels form porous structures whose physical state is between a liquid and a solid phase. Further to this, Ayeldeen et al.,(2016) through the use of Scanning Electron Microscopy (SEM) imaging reported that the hydrogels of biopolymers transform from a “rubbery” to “glassy” state with time. The nature of these transformations may further be linked with functional groups of polymer backbone and side chains (Gerlach and Arndt, 2009). However, the mechanical properties of these hydrogels during the transformation is still uncertain. As XRCT scanning produces tomographs based on material properties, an exploratory investigation was undertaken to obtain scans for biopolymer stabilised soil specimens to visually inspect the physical nature of hydrogels in comparison to soil particles.

In this investigation, cylindrical specimens of dimension 36 mm diameter and 78 mm height of soil mix 2-7-1 stabilised with 2% of biopolymer were prepared according to the preparation method mentioned in section [3.3.2.1](#). The samples were prepared to achieve similar density as those of UC test specimens and were cured in similar laboratory conditions. XRCT images were obtained using an XRadia/Zeiss XRM-410 machine based at the Durham University XCT service (ZEISS, 2014). Smith (2015) noted that the XRM-410 can perform scans for samples up to 300mm diameter at different resolution from 1 to 40  $\mu\text{m}$ , however, it was also reported that XRM-410 took a considerable amount of time to scan samples with large dimensions at higher resolutions. Effectively one has to balance the desire for high resolution with a corresponding smaller field of view. Hence, arriving at optimised scan parameters for a

sample with known dimensions, could enable one to reduce the scan time. In this investigation, a resolution of  $8.5\ \mu\text{m}$  was obtained, which was similar to the study in Beckett et al.,(2013) also for earthen construction materials. For a given specimen, after 7 days of curing, the sample was scanned in the XRCT machine. For this resolution, the typical scan lasted about 14-16 hours. After the completion of the scan, the sample was then shifted back to the laboratory to cure. The specimen was scanned again after 28 days of curing.

### 3.3.4.3. Qualitative analysis

XRCT tomographies were processed into 2-D slices across the diameter of the specimens. Due to the restriction of space here, only one slice for each sample at particular curing period is presented. Figs 3.21a and 3.21b, show the 2-D slice for the samples stabilised with guar gum at 7 and 28 days respectively, while Figs 3.16c and 3.16d are for the xanthan gum stabilised specimens.

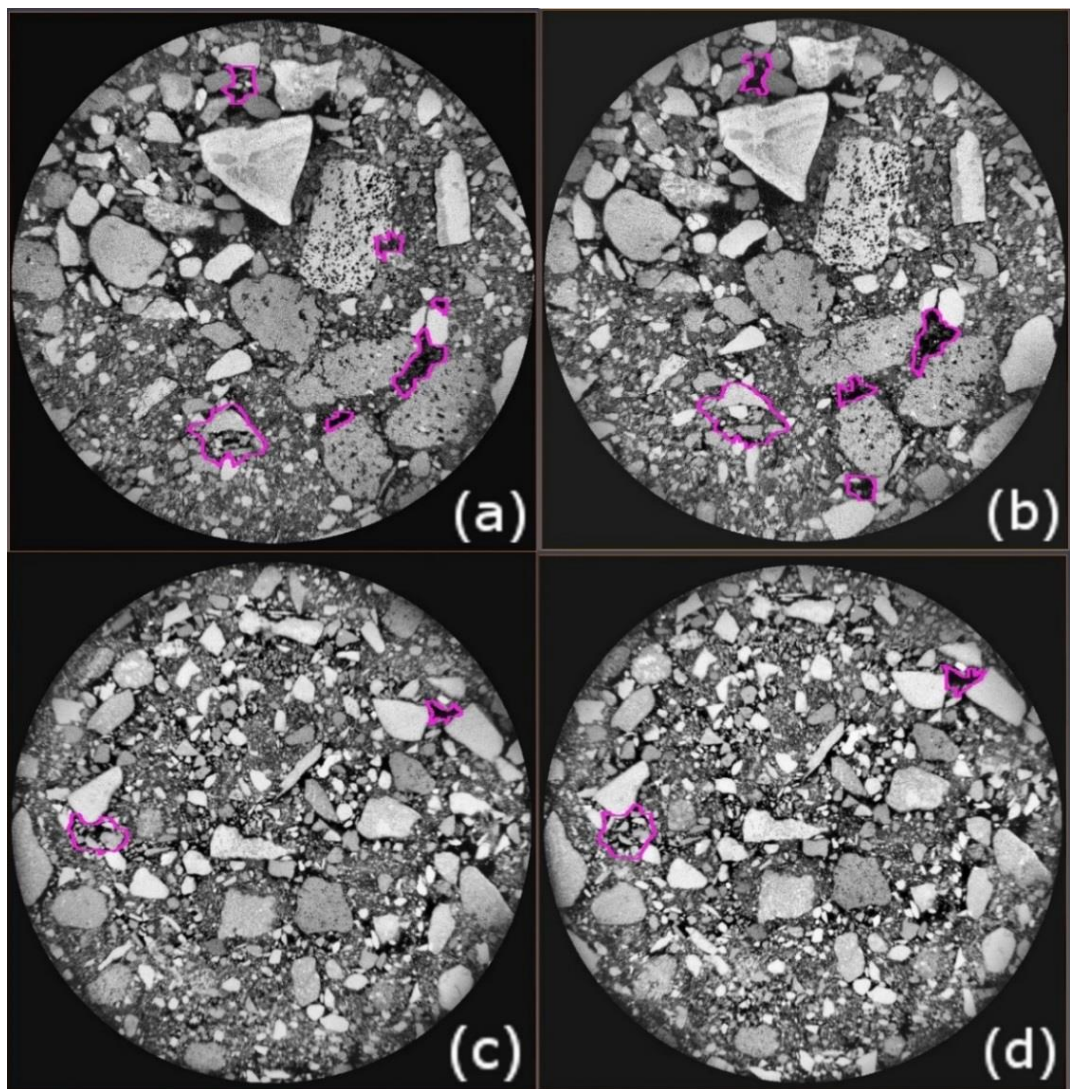

Figure 3.21. XRCT Scan images for guar gum (a & b) and xanthan gum (c & d) stabilised specimens after 7 and 28 days respectively.

The brightest regions correspond to the densest material in the specimen such as gravel or coarse sand portions of the soil mix, while the darkest regions correspond to pore spaces which have low or zero density. The main intention of these scans was to capture the transformation of hydrogels from “rubbery” to “glassy” state as noted by Ayeldeen et al.,(2016), however, hydrogels are necessarily three-dimensional porous structure(Brax et al., 2017). Being porous, hydrogels may also have less significant attenuation effects on x-rays and thus at this resolution it was not possible to capture the network of hydrogel formation, which was expected to be there. However, it was noted that both the biopolymer stabilised earthen materials had slight variations in void spaces between 7 and 28 days of curing period (highlighted portions shown in Fig 3.21). Compared to the xanthan gum stabilised earthen material, this rearrangement was more evident for guar gum stabilised specimens. Though this preliminary investigation was not able to capture hydrogel formation at this level of resolution, it is evident that the addition of biopolymer has a noticeable effect on the macrostructure of the stabilised material. Scanning was undertaken on a sample with smaller dimensions and results were quantitatively analysed to compare the differences between unamended and stabilised samples. Detailed discussions about these analyses are presented in the next chapter.

### 3.3.5 Preliminary durability tests

Durability is a key parameter which determines the acceptance of earthen construction material as a building material. As noted in the previous chapter, international standards across the world recommend different durability tests. Standard durability tests like ASTM D559(1989) and IS 1725(2013) are primarily aimed at the assessment of cement stabilised earthen materials; however, use of these tests to assess earthen materials amended using alternative stabilisers may not be appropriate. Hence, based on the stabiliser chosen an appropriate durability test procedure needs to be adopted. In this preliminary campaign to assess durability performance of biopolymer stabilised earthen material, the water erosional test, i.e. the “Geelong” test as prescribed by New Zealand technical standard (NZS 4298, 1998) was chosen.

#### 3.3.5.1. Sample preparation and testing methodology

To assess the durability performance of biopolymer stabilised earthen construction materials, earthen cubes with 150 mm sides, stabilised with 1.5% of biopolymer content, were prepared. For the preparation, all the ingredients were dry mixed initially and later water was added and mixed thoroughly for 10-15 minutes using a mechanical mixer. The bulk soil mix was then divided into three equal parts and introduced to the mould one part at a time. Using a vibratory hammer, each layer was compacted to the required density. These steps were repeated for all the three portions. All blocks were compacted to achieve identical initial dry density as that of the unconfined compressive test specimens described in section [3.3.2.1](#). Once the block was moulded, it was taken out carefully and left to air cure at a relative humidity of 50% and

temperature of 21°C. After 7 and 28 days of curing, the earthen blocks were tested for resistance against water erosion as per the test procedure described in the code.

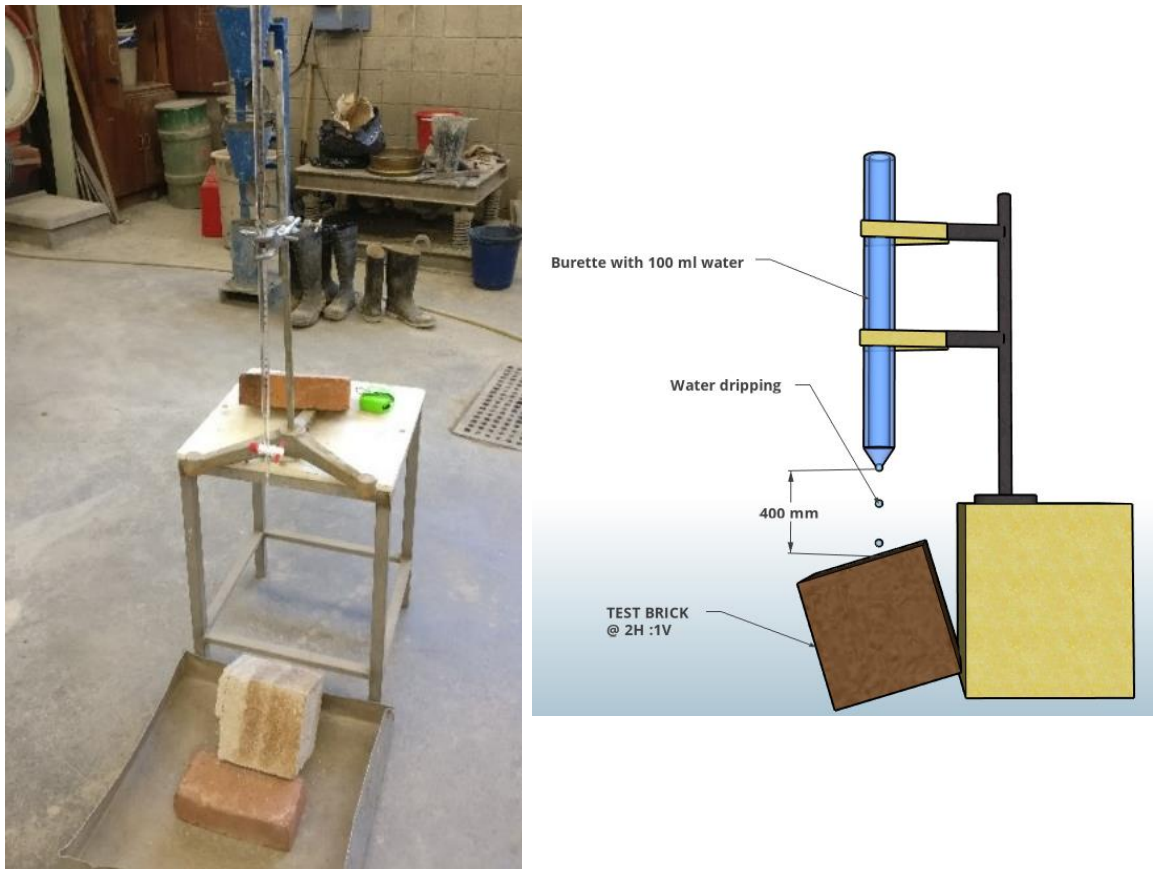

Figure 3.22. Test setup for durability test as per NZS 4298 (1998)

Figure 3.22 shows the test setup for performing the Geelong test. The test procedure involves dripping 100ml of water from a height of 400mm on to the surface of a prepared earthen block kept at an inclination of 2H:1V. 100ml of water is applied within a time period of 20-60 minutes. After dripping is complete, the surface of the block is wiped using a wire brush to remove the eroded soil particles and the depth of erosion is measured using a Vernier calliper with a depth gauge having a precision of 0.02mm. According to the standard, if the depth of erosion is within 5mm from surface, the earthen construction material is considered to have passed the erosion tests.

### 3.3.5.2. Test results

Figures 3.23a and 3.23b show the eroded surfaces of the earthen blocks stabilised with guar gum and xanthan gum respectively at 7 days of aging. Table 3.7 presents the depth of erosion for both earthen blocks at 7 and 28 days respectively. The measured depth of erosion for both blocks was within 5 mm and this eroded depth is well within permissible limits of NZS 4298 (1998) corresponding to an erodibility index of 3. Similar behaviour was observed at 28 days. It was noted that the surface exposed to dripping was intact after durability tests for both the

blocks stabilised with guar gum and xanthan gum respectively. Against varying atmospheric conditions, the physical appearance of earthen materials was also assessed. It was noted that for the guar gum stabilised block, the sides and edges had worn off, while for the xanthan gum stabilised block these areas remained intact.



Figure 3.23. Eroded surface after durability tests (a) guar gum and (b) xanthan gum

Table 3.7. Tests results of preliminary durability tests.

| Combination | Depth of erosion (mm) |        |
|-------------|-----------------------|--------|
|             | 7 day                 | 28 day |
| Guar gum    | 0.75                  | 0.85   |
| Xanthan gum | 0.25                  | 0.30   |

This preliminary campaign was to assess the potential of these biopolymers as stabilisers for earthen construction materials, it being important that any new materials were both strong enough and possessed good durability. The results suggest that biopolymer stabilised earthen materials perform satisfactorily and indicate both biopolymers have potential of being an alternative to cement as a stabiliser. Further erosional tests have been carried out with varying sample geometry. Furthermore, other durability tests such as dip, contact and suction tests which emulate capillary rise deterioration and sudden submergence have been performed for biopolymer stabilised earthen construction materials. Results of this detailed durability studies are presented in Chapter 5 of the thesis.

### 3.4 Concluding remarks

Based on this initial investigation on biopolymer stabilisation, important aspects of biopolymer soil stabilisation are summarised below.

1. Based on the strength tests, it can be noted that under ambient conditions, both soil suction and hydrogel formation appear to contribute to the overall strength of the biopolymer stabilised earthen material.
2. The nature in which these hydrogels interact with soil particles is dependent on the intrinsic characteristics of the biopolymer used. As a neutrally charged polysaccharide, guar gum essentially interacts with soil and water through hydrogen bonding, while xanthan gum which is an anionic polysaccharide interacts through hydrogen and ionic bonding.
3. The nature of hydrogel interaction with soil particles has due influence on mechanical behaviour especially the tensile strength and soil modulus. It was noted that the additional ionic bonding of xanthan gum appeared to lead to higher tensile strengths of the stabilised earthen material.
4. For both biopolymers, about 1.5% of biopolymer content of the dry soil mass was sufficient to achieve comparable compressive strength of 8.0% cement stabilised earthen material. However, comparable tensile strength was only achieved by xanthan gum stabilised earthen material at 2.0% of biopolymer content.
5. There was no drastic improvement in strength for earthen construction materials stabilised with biopolymers in synergy. However, research findings from this investigation which highlights the potential of biopolymer synergy may be useful from a mechanical point of view if use of biopolymers in combination is found to be more environmentally sustainable.
6. Initial XRCT scans could not capture the hydrogel formation at the chosen resolution. However, slight changes in particle re-arrangement were noted for scans between 7- and 28-days curing period.
7. Preliminary durability tests indicate that earthen materials stabilised with these biopolymers have satisfactory performance. Between biopolymers, xanthan gum stabilised earthen material had better performance.

It can be observed from strength tests that both soil suction and hydrogel formation contribute to strength of biopolymer stabilised earthen material. While, XRCT scans reveal addition of biopolymer may have an influence on soil structure. To further the understanding of biopolymer stabilisation, geotechnical characterisation of biopolymer stabilised earthen construction material is undertaken which is presented in the next chapter of the thesis. Preliminary durability tests indicate both guar and xanthan gums show potential of being an alternative stabiliser for earthen construction materials. In order to understand the potential of biopolymer stabilised earthen material as a building material, detailed durability performance, hygroscopic behaviour and recycling potential have been evaluated. The results of this assessment are presented in Chapter 5 of the thesis.

### References

- AFNOR. 2001. XP P13-901; Compressed earth blocks for walls and partitions: definitions – Specifications – Test methods – Delivery acceptance conditions.
- Araki H, Koseki J, and Sato T. 2016. Tensile strength of compacted rammed earth materials. *Soils and Foundations*, 56(2), 189–204.
- ASTM-D559. 1989. Wetting and Drying Compacted Soil- Cement Mixtures. Philadelphia: American Society for Testing and Materials.
- Ayeldeen MK, Negm AM, and El Sawwaf MA. 2016. Evaluating the physical characteristics of biopolymer/soil mixtures. *Arabian Journal of Geosciences*, 9(5), 329–339.
- Beckett C. 2011. The Role of Material Structure in Compacted Earthen Building Materials: Implications for Design and Construction. Durham University. Retrieved from <http://etheses.dur.ac.uk/3313/>
- Beckett C, Augarde CE, Easton D, and Easton T. 2017. Strength characterisation of soil-based construction materials. *Géotechnique*.
- Beckett C, Hall MR, and Augarde CE. 2013. Macrostructural changes in compacted earthen construction materials under loading. *Acta Geotechnica*, 8(4), 423–438.
- Brax M, Buchmann C, and Schaumann GE. 2017. Biohydrogel induced soil-water interactions: how to untangle the gel effect? A review. *Journal of Plant Nutrition and Soil Science*, 180(2), 121–141.
- BS-EN-197-1. 2011. Cement Part 1: Composition, specifications and conformity criteria for common cements. London: BSI.
- BS 1377-2. 1990. Methods of test for Soils for civil engineering purposes - Part 2: Classification tests. London: BSI.
- BS 1377-4. 1990. Methods of test for Soils for civil engineering purposes - Part 4: Compaction tests. London: BSI.
- BS 1377-7. 1990. Methods of test for Soils for civil engineering purposes - Part 7: Shear strength tests (total stress). London: BSI.
- Bui QB, and Morel JC. 2009. Assessing the anisotropy of rammed earth. *Construction and Building Materials*, 23(9), 3005–3011.
- Bui QB, Morel JC, Hans S, and Walker P. 2014. Effect of moisture content on the mechanical characteristics of rammed earth. *Construction and Building Materials*, 54, 163–169.
- Bui TT, Bui QB, Limam A, and Maximilien S. 2014. Failure of rammed earth walls: From observations to quantifications. *Construction and Building Materials*, 51, 295–302.
- Burroughs S. 2008. Soil Property Criteria for Rammed Earth Stabilization. *Journal of Materials in Civil Engineering*, 20(3), 264–273.
- Cabalar AF, and Canakci H. 2011. Direct shear tests on sand treated with xanthan gum. *Proceedings of the ICE - Ground Improvement*, 164, 57–64.
- Cao J, Jung J, Song X, and Bate B. 2017. On the soil water characteristic curves of poorly graded granular materials in aqueous polymer solutions. *Acta Geotechnica*.
- Casas JA, Mohedano AF, and García-Ochoa F. 2000. Viscosity of guar gum and xanthan/guar gum mixture solutions. *Journal of the Science of Food and Agriculture*, 80(12), 1722–1727.
- Chan C-M, and Low L-P. 2014. Development of a Strength Prediction Model for “Green” Compressed Stabilised Earthbricks. *Journal of Sustainable Development*, 3(3), 140–150.
- Chang I, Im J, and Cho G-C. 2016. Introduction of Microbial Biopolymers in Soil Treatment for Future Environmentally-Friendly and Sustainable Geotechnical Engineering. *Sustainability*, 8(3), 251.
- Chang I, Im J, Prasadhi AK, and Cho G-C. 2015. Effects of Xanthan gum biopolymer on soil strengthening. *Construction and Building Materials*, 74(10), 65–72.
- Chang I, Kwon Y-M, Im J, and Cho G-C. 2018. Soil consistency and inter-particle characteristics of xanthan gum biopolymer containing soils with pore-fluid variation. *Canadian Geotechnical Journal*, (October), cgj-2018-0254.
- Chen R. 2014. Bio Stabilisation for Geopolymer Enhancement and Mine tailings Dust Control. The University of Arizona. Retrieved from <http://hdl.handle.net/10150/319999>
- Chen R, Zhang L, and Budhu M. 2013. Biopolymer Stabilization of Mine Tailings. *Journal of Geotechnical and Geoenvironmental Engineering*, 139(October), 130128212232006.
- Chudzikowski RJ. 1971. Guar gum and its applications. *Journal of the Society of Cosmetic Chemists*, 22(1), 43–60.
- CRATerre-EAG. 1998. CDI, Compressed earth blocks: Standards – Technology series No.11. Brussels:CDI.
- Cristelo N, Glendinning S, Miranda T, Oliveira D, and Silva R. 2012. Soil stabilisation using alkaline activation of fly ash for self compacting rammed earth construction. *Construction and Building Materials*, 36, 727–735.
- Decagon Devices. 2015. WP4C WATER POTENTIAL METER. Retrieved June 8, 2017, from <http://www.decagon.com/en/soils/benchtop-instruments/wp4c-water-potential-meter/>
- Decagon Devices I. 2007. Dewpoint PotentiaMeter. WP4C PotenciaMeter. Operator’s Manual, Version 2, 66. Retrieved from [www.decagon.com](http://www.decagon.com)

## Chapter 3. Biopolymer Stabilisation

---

- Etzion Y, and Saller M. 1987. Earth Construction—A Review of Needs and Methods. *Architectural Science Review*, 30(2), 43–48.
- Fitzmaurice R. 1958. Manual on stabilized soil construction for housing. New York: United Nations, Technical Assistance Programme.
- García-Ochoa F, Santos VE, Casas JA, and Gomez E. 2000. Xanthan gum: production, recovery, and properties. *Biotechnology Advances*, 18(7), 549–579.
- Gerlach G, and Arndt K-F. 2009. Hydrogel sensors and actuators: engineering and technology (Vol. 6). Springer Science & Business Media.
- Gomes MI, Lopes M, and de Brito J. 2011. Seismic resistance of earth construction in Portugal. *Engineering Structures*, 33(3), 932–941.
- Hall M, and Djerbib Y. 2004. Rammed earth sample production: context, recommendations and consistency. *Construction and Building Materials*, 18(4), 281–286.
- Hallal MM, Sadek S, and Najjar SS. 2018. Evaluation of Engineering Characteristics of Stabilized Rammed-Earth Material Sourced from Natural Fines-Rich Soil. *Journal of Materials in Civil Engineering*, 30(11), 4018273.
- Helliwell JR, Sturrock CJ, Grayling KM, Tracy SR, Flavel RJ, Young IM, ... Mooney SJ. 2013. Applications of X-ray computed tomography for examining biophysical interactions and structural development in soil systems: a review. *European Journal of Soil Science*, 64(3), 279–297.
- Houben H, and Guillaud H. 1994. Earth construction: a comprehensive guide. Intermediate Technology Publications.
- IMERYS. 2007. Speswhite China Clay - Data sheet (Vol. 44). Ilford, Essex.
- Intralabs. 2016a. Guar gum: product information. Retrieved May 17, 2019, from <http://www.intralabs.co.uk/guar-gum.html>
- Intralabs. 2016b. Xanthan gum: product information. Retrieved May 17, 2019, from <http://www.intralabs.co.uk/xanthan-gum.html>
- IS 1725. 2013. Indian Standard IS 1725: Stabilized soil blocks used in general building construction — Specification. New Delhi: Bureau of Indian Standards.
- Jang D-J, Frost JD, and Park J-Y. 1999. Preparation of epoxy impregnated sand coupons for image analysis. *Geotechnical Testing Journal*, 22(2), 153–164.
- Jaquin PA, Augarde CE, Gallipoli D, and Toll DG. 2009. The strength of unstabilised rammed earth materials. *Géotechnique*, 59(5), 487–490.
- Jiménez Delgado MC, and Guerrero IC. 2007. The selection of soils for unstabilised earth building: A normative review. *Construction and Building Materials*, 21(2), 237–251.
- Katzbauer B. 1998. Properties and applications of xanthan gum. *Polymer Degradation and Stability*, 59(1–3), 81–84.
- Kocherbitov V, Ulvenlund S, Briggner L-E, Kober M, and Arnebrant T. 2010. Hydration of a natural polyelectrolyte xanthan gum: Comparison with non-ionic carbohydrates. *Carbohydrate Polymers*, 82(2), 284–290.
- Krishna Leela J, and Sharma G. 2000. Studies on xanthan production from *Xanthomonas campestris*. *Bioprocess Engineering*, 23(6), 687–689.
- Lakshmikantha MR, Prat PC, and Ledesma A. 2012. Experimental evidence of size effect in soil cracking. *Canadian Geotechnical Journal*, 49(3), 264–284.
- Latifi N, Horpibulsuk S, Meehan CL, Majid MZA, and Rashid ASA. 2016. Xanthan gum biopolymer: an eco-friendly additive for stabilization of tropical organic peat. *Environmental Earth Sciences*, 75(9).
- Liu Q, and Tong L. 2017. Engineering properties of unstabilized rammed earth with different clay contents. *Journal of Wuhan University of Technology-Mater. Sci. Ed.*, 32(4), 914–920.
- Lo Y-M, Yang S-T, and Min DB. 1997. Ultrafiltration of xanthan gum fermentation broth: Process and economic analyses. *Journal of Food Engineering*, 31(2), 219–236.
- Maniatidis V, and Walker P. 2003. A Review of Rammed Earth Construction. Bath, United Kingdom.
- Mooney SJ, Pridmore TP, Helliwell J, and Bennett MJ. 2012. Developing X-ray Computed Tomography to non-invasively image 3-D root systems architecture in soil. *Plant and Soil*, 352(1–2), 1–22.
- MOPT. 1992. Bases Para el Diseño y Construcción con Tapial. Madrid, Spain: Centro de Publicaciones., Secretaría General Técnica, Ministerio de Obras Públicas y Transportes.
- Nearing MA, Parker SC, Bradford JM, and Elliot WJ. 2010. Tensile Strength of Thirty-Three Saturated Repacked Soils. *Soil Science Society of America Journal*, 55(6), 1546.
- Nugent RA, Zhang G, and Gambrell RP. 2009. Effect of Exopolymers on the Liquid Limit of Clays and Its Engineering Implications. *Transportation Research Record: Journal of the Transportation Research Board*, 2101(1), 34–43.
- NZS 4297. 1998. Engineering design of earth buildings (Vol. 4297). Wellington: Standards New Zealand.
- NZS 4298. 1998. Materials and workmanship for earth buildings [Building Code Compliance Document E2 (AS2)]. New Zealand Technical Committee. Wellington: Standards New Zealand.
- Qureshi MU, Chang I, and Al-Sadarani K. 2017. Strength and durability characteristics of

## Chapter 3. Biopolymer Stabilisation

---

- biopolymer-treated desert sand. *Geomechanics and Engineering*, 12(5), 785–801.
- Reddy B, and Jagadish KS. 1995. Influence of soil composition on the strength and durability of soil-cement blocks. *Indian Concrete Journal*, 69(9), 517–524.
- Reddy B, Lal R, and Rao KN. 2007. Optimum Soil Grading for the Soil-Cement Blocks. *Journal of Materials in Civil Engineering*, 19(2), 139–148.
- Rigby SP, Chigada PI, Wang J, Wilkinson SK, Bateman H, Al-Duri B, ... Miri T. 2011. Improving the interpretation of mercury porosimetry data using computerised X-ray tomography and mean-field DFT. *Chemical Engineering Science*, 66(11), 2328–2339.
- Roscoe K. 1970. The Influence of Strains in Soil Mechanics. *Géotechnique*, 20(2), 129–170.
- Smith J. 2015. Examining Soil Based Construction Materials through X-Ray Computed Tomography. Durham University. <https://doi.org/ear>
- Stirling RA, Hughes P, Davie CT, and Glendinning S. 2015. Tensile behaviour of unsaturated compacted clay soils - A direct assessment method. *Applied Clay Science*, 112–113, 123–133.
- Towner GD. 1987. The mechanics of cracking of drying clay. *Journal of Agricultural Engineering Research*, 36(2), 115–124.
- Walker P, Keable R, Martin J, and Maniatidis V. 2005. *Rammed Earth: Design and Construction Guidelines*. Watford: BRE Bookshop Watford.
- Walker P, and Stace T. 1997. Properties of some cement stabilised compressed earth blocks and mortars. *Materials and Structures/Materiaux et Constructions*, 30(203), 545–551.
- Wellington SL, and Vinegar HJ. 1987. X-ray computerized tomography. *Journal of Petroleum Technology*, 39(8), 885–898.
- Young IM, and Crawford JW. 2004. Interactions and self-organization in the soil-microbe complex. *Science*, 304(5677), 1634–1637.
- ZEISS. 2014. ZEISS Xradia 410 Versa Submicron X-ray Imaging: Bridge the Gap in Lab-based Microscopy. Jena, Germany: Carl Zeiss Microscopy GmbH. Retrieved from <https://www.zeiss.com/microscopy/int/products/x-ray-microscopy/zeiss-xradia-410-versa.html>
- Zhao X. 2014. Measurements and transient multistep outflow simulation of soil-water characteristic curve for soils modified with biopolymers.

# Chapter 4

## Geotechnical characterisation of biopolymer stabilised earthen construction material

### 4.1 Chapter Introduction

Geotechnically, an earthen construction material can be considered to be a compacted soil mixture placed to form a structural unit such as a wall (Gallipoli et al., 2014). The compacted soil mixture is placed at a certain water content, the material is then allowed to dry to gain strength and in this condition the material is unsaturated. Further, during its time in-situ, the earthen construction material is exposed to different in-situ conditions which would alter the water content of the material and thereby its strength. In the case of unstabilised earthen construction materials, the change in material strength occurring due to water content variations can be linked with soil suction. Works by Jaquin et al.,(2009) and Bui et al.,(2014) describe the role of soil suction influencing the mechanical properties of earthen construction materials. Subsequent research studies have attempted to characterise earthen construction materials through concepts of unsaturated soil mechanics (Gerard et al., 2015; Beckett et al., 2017). Results from unconfined compression and tensile tests presented in Chapter 3 indicate that the strength of a biopolymer stabilised soil is derived from a combination of soil suction and hydrogel formation. As a continuation to understand the role of soil suction and hydrogel formation on hydraulic and mechanical properties of biopolymer stabilised soils, further investigations were carried out. The testing procedure and results of these investigations are presented in this chapter.

### 4.2 Shear Strength of Unsaturated soils

As discussed in Chapter 2, the shear strength of saturated soil is usually evaluated in terms of the Mohr Coulomb (MC) failure criterion (see Section 2.3). In the case of unsaturated soil, the strength behaviour is typically described through an extended Mohr Coulomb (EMC) failure criterion as formulated by Fredlund et al.,(1973). The stress state variables namely, net normal stress ( $\sigma - u_a$ ) and matric suction ( $u_a - u_w$ ) are commonly used to define the EMC failure envelope. In the form of an equation, the shear strength of unsaturated soil is expressed as follows:

$$\tau_f = c' + (\sigma - u_a)_f \tan \phi' + (u_a - u_w)_f \tan \phi^b \quad (4.1)$$

where,

$\tau_f$  is the shear stress at failure,

$c'$  is intercept of the “extended” Mohr-Coulomb failure envelope on the shear stress axis where the net normal stress and the matric suction at failure are equal to zero.

$(\sigma - u_a)_f$  is net normal stress state on the failure plane at failure

$\sigma$  is the total normal stress at failure

$(u_a - u_w)_f$  is the matric suction on the failure plane at failure

$u_w$  is the pore-water pressure at failure

$u_a$  is the pore-air pressure at failure

$\phi'$  is the effective angle of internal friction

$\phi^b$  is the angle indicating the rate of increase in shear strength relative to the matric suction.

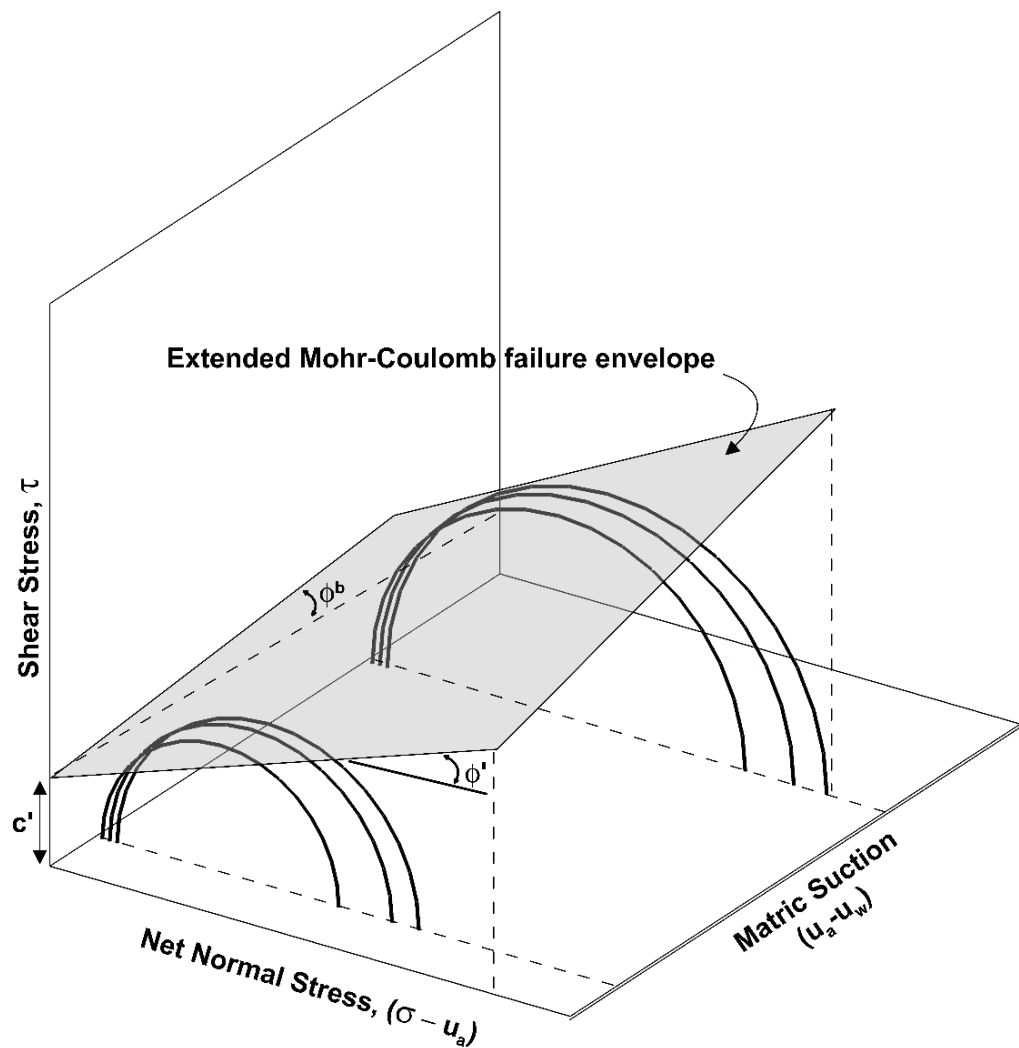

Figure 4.1 Illustration of the extended Mohr-Coulomb failure criterion.

The first two terms on the right hand side of the extended Mohr-Coulomb equation (4.1) describes the relation between shear strength and normal stress. Similar to a saturated soil, the

shear strength of unsaturated soil increases with net normal stress. On the other hand, the effect of matric suction on shear strength is different to that of normal stress (Jennings and Burland, 1962). The effect of matric suction is captured by the last term on the right hand side of Equation 4.1, i.e.  $(u_a - u_w)_f \tan \phi^b$ . In the extended Mohr-Coulomb failure envelope, Mohr circles corresponding to the failure are plotted in three-dimensions. Figure 4.1 illustrates a typical extended Mohr-Coulomb failure envelope for unsaturated soils. In the three-dimensional plot, shear stress,  $\tau$  is ordinate, while the two stress variables namely, net normal stress  $(\sigma - u_a)$  and matric suction  $(u_a - u_w)$  are abscissas. The Mohr circles for unsaturated soils are plotted with respect to net normal stress axis, similar to Mohr circles of saturated soils. However, in the plot, the location of the Mohr circle is a function of matric suction of the soil. The planar surface which is tangent to all the Mohr circles at different matric suctions is referred to as the extended Mohr-Coulomb failure envelope for the unsaturated soil. It is clear from the above description that to develop an EMC failure envelope for an unsaturated soil, laboratory determination of net normal stress and soil suction are essential.

Gerard et al., (2015) measured total suction for air dried rammed earth materials using the vapour equilibrium method. It was observed that under the ambient conditions (40 % relative humidity and 20°C temperature), the total suction of the air-dried rammed earth was 125 MPa. When the humidity level was changed to 97 %, the total suction of the material reduced to 4 MPa. Beckett et al.,(2017) in their study to characterise air dried rammed earth material observed total suctions in the range of 14 – 174 MPa under constant temperature of 20°C and varying humidity levels of 30 – 90%. In Chapter 3, the values of total suction of the material determined through dew point potentiometer after the strength tests were in range of 80 – 125 MPa. From the above discussion, it is clear that, under ambient conditions, an earthen construction material has high suction ( $> 4$  MPa). In this scenario, it is appropriate to understand the mechanical and hydraulic behaviour of the earthen construction material which is under this high suction regime. However, laboratory estimation of matric suction presents difficulties as current available laboratory techniques measure suction values only up to 1.5 MPa (Lu and Likos, 2004). Hence, in this study, to characterise earthen construction materials determination of total suction was considered to be more appropriate rather than matric suction. Further, in high suction regimes, values of total and matric suctions are comparable as the effect of osmotic suction in this regime would be negligible.

### 4.3 Experimental Programme

As discussed previously, the shear strength of an unsaturated soil is dependent on soil suction. The strength tests presented in Chapter 3 suggest that the strength of biopolymer stabilised soils is due to the combination of soil suction and hydrogel formation. In order to obtain a deeper understanding on how biopolymers affect shear strength parameters and soil suction with aging, an experimental programme to determine hydraulic and mechanical properties of guar and

## Chapter 4. Geotechnical Characterisation

xanthan gum stabilised soils was formulated. To obtain hydraulic properties, soil-water retention curves for biopolymer stabilised soils were determined, while for the mechanical properties, strength tests in the form of triaxial tests at different designated curing periods were conducted. Further, to understand the effect of biopolymers on soil structure with aging due to hydrogel formation, X-ray computed tomography scanning of biopolymer stabilised soils at designated curing periods was undertaken.

### 4.4 Suction tests

#### 4.4.1 Testing methodology

In the study of Beckett et al.,(2017), total suction for an air dried rammed earth material varied from 14 MPa (at higher humidity) to 174 MPa (at low humidity). Considering these high suction values, it was decided for the present investigation, total suction measurement would be undertaken using a WP4c dew point potentiometer(Decagon Devices, 2015). In the present investigation, suction specimens of 35 mm diameter and 8 mm thickness which can easily fit into the sample cup of the WP4c dew point potentiometer were prepared to obtain total suction values in the high suction regime. In order to eliminate the effect of maximum particle size on the sample, an engineered soil mix passing through a 2.0 mm sieve was used to prepare the specimen. Unamended, guar and xanthan gum stabilised suction specimens were prepared for this investigation. The stabiliser content for biopolymer stabilised specimens was maintained at 2.0% of dry soil mass.

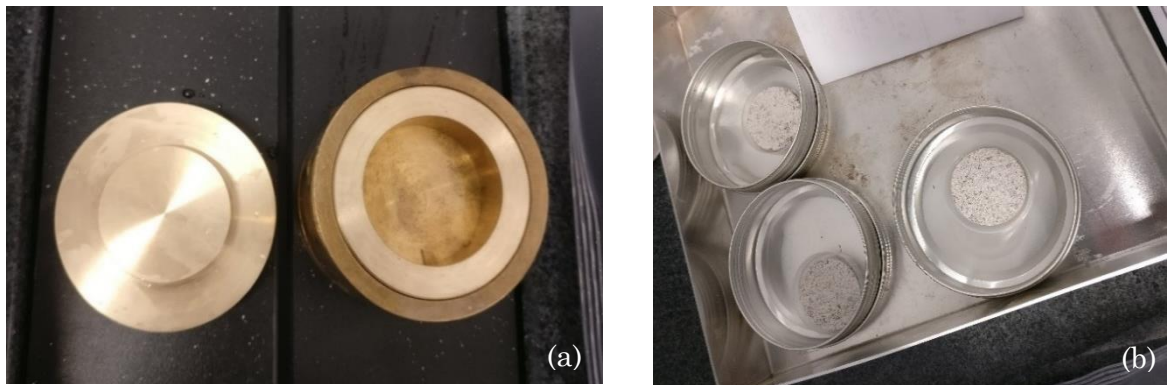

Figure 4.2. Suction tests, (a) Specimen mould used to prepare suction specimens and (b) Moisture content tin containing suction cup and specimen.

In order to make suction specimens, the required quantities (on a mass basis) of the ingredients (80% sand passing through 2.0 mm sieve, 20 % kaolin and biopolymer) were weighed and initially dry mixed. For the stabilised specimens, biopolymer was pre-mixed with the dry soil mixture. After dry mixing, water equivalent to optimum water content and additional water required for making soil mix workable (for biopolymer stabilised specimens) was added and mixed thoroughly (See Section [3.3.2.1](#)). The bulk soil mix was then introduced into a mould specifically fabricated for preparing suction specimens (Figure 4.2a). The bulk soil mix was then

compacted to achieve the desired density. The freshly prepared specimen was then carefully transferred to the suction cup (used for determining total suction using WP4c dew point potentiometer) to determine total suction. Subsequently, the time and the mass of the moisture content tin cup containing the suction cup with soil specimen were recorded. The specimen was then left to dry under laboratory conditions (temperature of 21°C and relative humidity (RH) varying between 45 – 70%). Total suction, time and mass of specimen were recorded periodically for 28 days. At the end of 28 days, after recording the final mass, the specimen was removed from the suction cup and water content was determined using the same moisture content tin. Based on the mass of suction cup and final dry mass of the specimen, the water content of the specimen at different periods was back calculated. From this exercise, total suction and corresponding gravimetric water content at different time periods were obtained. The tests were performed for three replicates of specimens.

### 4.4.2 Test results

#### 4.4.2.1. Suction test results

The results obtained from suction tests, i.e. total suction and corresponding gravimetric water content values were plotted against time for unamended, guar and xanthan gum stabilised soils in Figures 4.3, 4.4 and 4.5 respectively. The total suction values corresponding to maximum and minimum humidity levels of the laboratory were determined using the Kelvin equation (4.1). As a reference, total suction values corresponding to maximum and minimum humidity changes have been included in these plots. The Kelvin equation is given by,

$$\Psi = - \frac{\rho_w RT}{w_v} \ln(RH) \quad (4.1)$$

where,

$\Psi$  is Total suction, R is universal gas constant, T is absolute temperature,  $\rho_w$  is the density of water, and  $w_v$  is the molecular mass of water vapour (Lu and Likos, 2004).

From Figures 4.3 to 4.5, it is obvious that under ambient conditions in the laboratory, the specimen starts to dry, which increases soil suction while water content decreases. In each of the plots, the change in water content due to drying can be divided into three distinct regions. These three distinct regions relate to different stages of evaporation which occur from the soil. As reported by Hillel(1980), the drying of water from the soil surface occurs in three different phases. The maximum rate of drying occurs when the soil is near to its saturation and the drying is controlled by climatic conditions. During this phase, within the soil, the largest pores start to desaturate when it reaches its limiting suction, and at this stage, air starts to enter the soil. In the second phase of drying, the soil conductive properties no longer allow easy movement of water molecules within the soil pores. In this phase, there is a steep decrease in water content as finer pores start to desaturate. Lastly, in the residual phase, the drying of water occurs slowly and mainly due to the process of vapour diffusion. In this residual phase, the suction is basically

---

## Chapter 4. Geotechnical Characterisation

in the residual zone of the SWRC, where only small changes in water content occur even from a high variation of suction. In this phase, water is primarily held as absorbed water on clay particles rather than capillary water (McQueen and Miller, 1974). Wilson (1994) notes that the rate of drying during this phase is controlled by ambient conditions and soil properties such as hydraulic conductivity and vapour diffusivity.

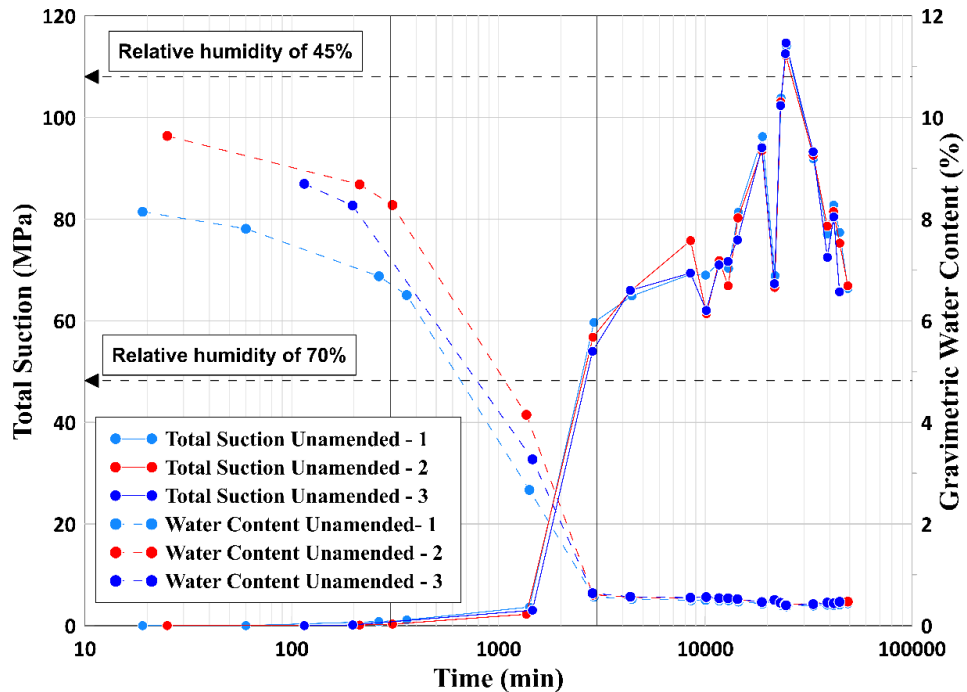

Figure 4.3. Variation of total suction and change in gravimetric water content with drying time of unamended specimens.

Initial observations may suggest that the rate of drying for all the three combinations is similar during the first two phases of drying, however, on closer examination it can be seen that there are slight variations. To have a better insight to the rate of drying for all combinations, an additional graph has been plotted which compares the first two phases of drying for unamended, guar and xanthan gum stabilised specimens (Figure 4.6). As seen from Figure 4.6, the higher initial water contents for biopolymer stabilised specimens may be linked to the additional water added on top of optimum moisture content to the soil-mix to make it workable. It is interesting to note that, in the second phase of drying, the rate of drying for guar gum stabilised specimens is higher than unamended and xanthan gum stabilised specimens. The plots for the guar gum stabilised specimens have steeper slopes than unamended and xanthan gum stabilised specimens. Though guar gum has higher affinity towards water than xanthan gum (Nugent et al., 2009), it appears that, on drying, water tends to escape easily from the stabilised soil specimen. This may be due to the fact that the water molecules are loosely held by biopolymer chains through weak chemical bonds such as hydrogen bonds. In the case of the xanthan gum stabilised specimens, the rate of drying is similar to that of unamended soil specimen, indicating that the hydrogel bonding is not so significant during this phase to slow the rate of drying.

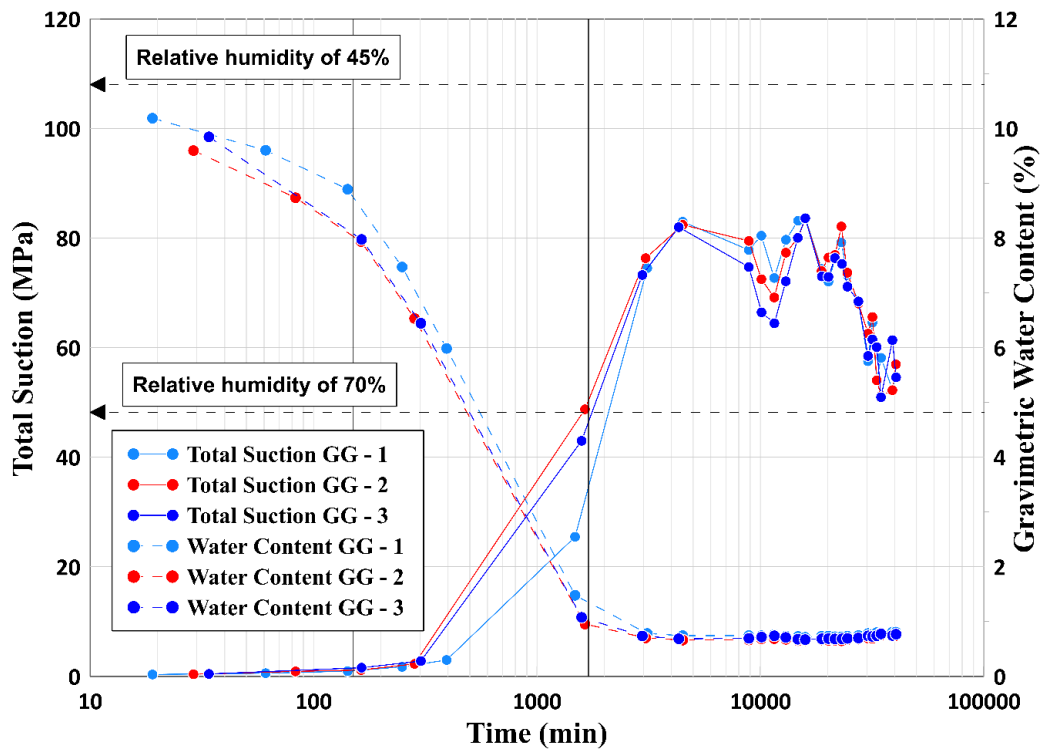

Figure 4.4. Variation of total suction and change in gravimetric water content with drying time of guar gum stabilised specimens

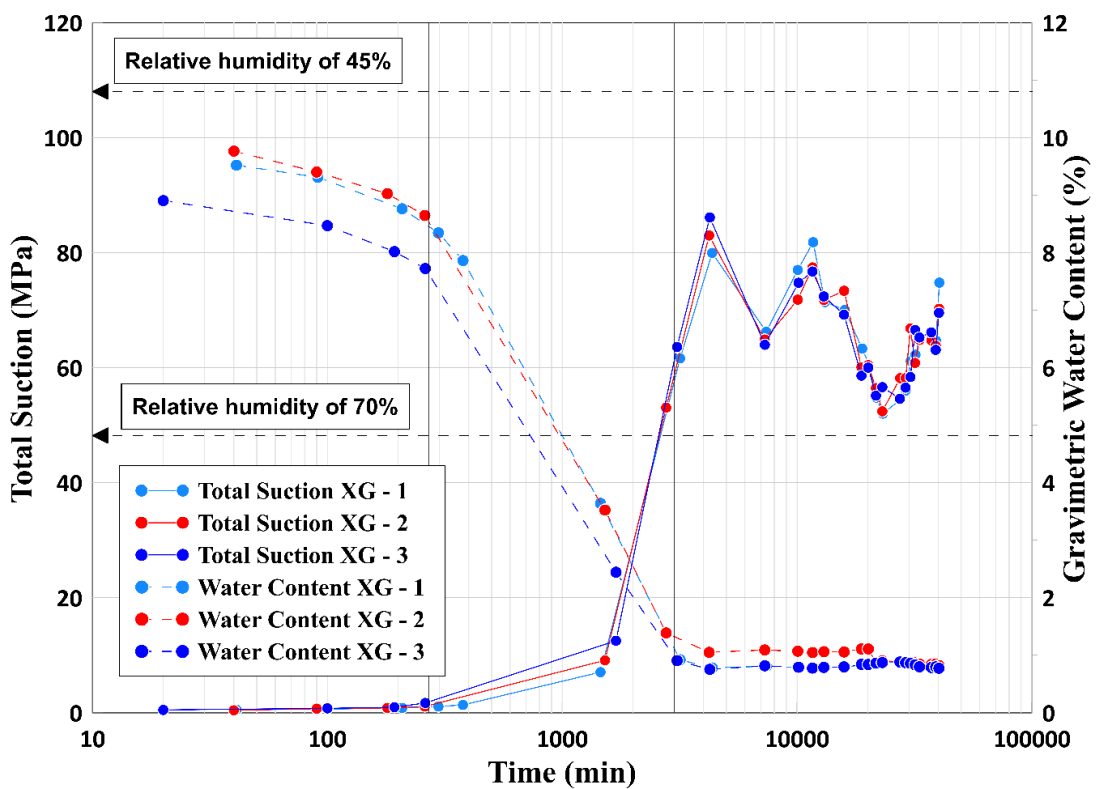

Figure 4.5. Variation of total suction and change in gravimetric water content with drying time of xanthan gum stabilised specimens

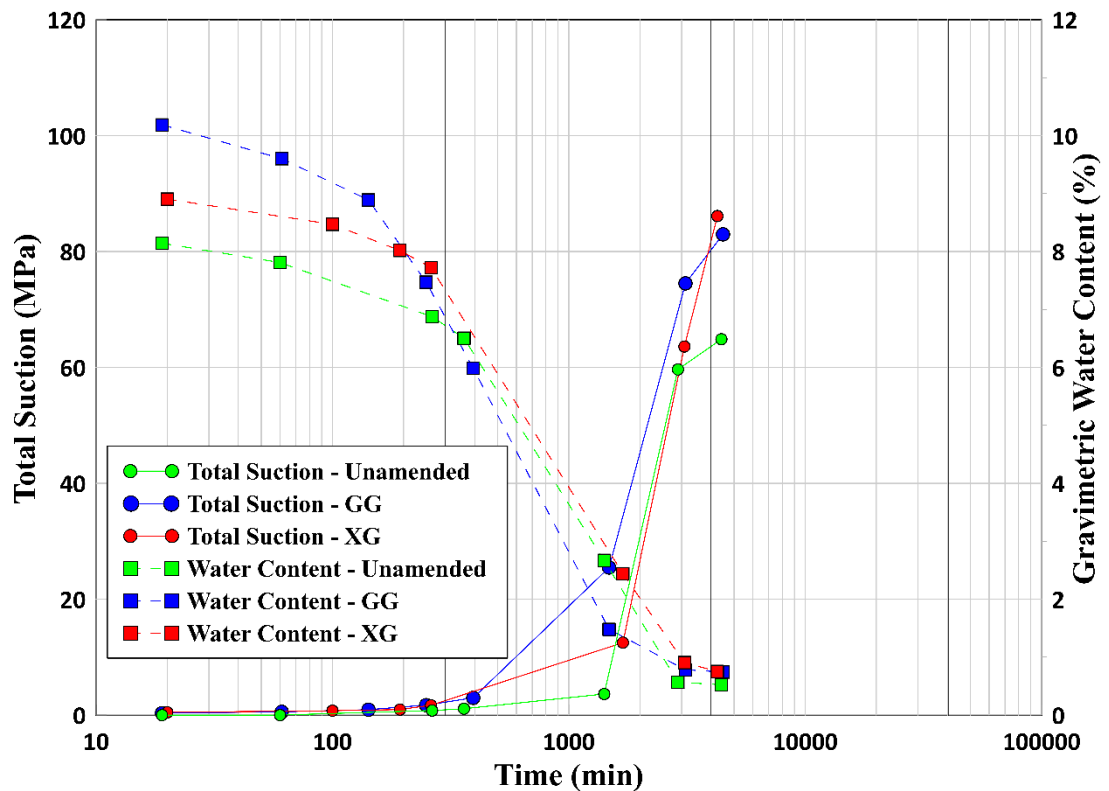

Figure 4.6. Comparison of variation of total suction and change in gravimetric water content with time of all specimens

In the residual phase of drying, the change in water content of the soil primarily occurs through vapour diffusion, which is dependent on ambient conditions and soil properties (Wilson et al., 1994). In the present investigation, drying was undertaken in a laboratory having a controlled temperature facility but varying humidity conditions. In this condition, it may be expected that when the specimen is in the residual zone, it may diffuse or absorb water from the immediate surroundings due to humidity changes. The effect of humidity changes can be noticed through variation of total suction in residual zone. In the case of an unamended specimen, apart from the humidity changes, the total suction may also be affected due to vapour absorption or diffusion caused by the principal clay mineral. Compared to an unamended specimen, biopolymer stabilised specimens have lower total suction variations which means they retain more water and are less susceptible to humidity changes. The vapour absorption/diffusion of biopolymer stabilised specimens is dependent on biopolymer type, state, temperature and humidity (Kocherbitov et al., 2010; Chen et al., 2019). Under similar ambient conditions, the variation in total suction values of biopolymer stabilised specimens may be associated with the biopolymer type and hydrogel state. As regards biopolymer type, xanthan gum, which has better water absorption capabilities than guar gum (Torres et al., 2012), has retained more water and hence the observed total suction values are lower. With respect to hydrogel state, they may be in the process of transformation from being in a rubbery to a glassy state. In this condition they

## Chapter 4. Geotechnical Characterisation

---

may have not reached complete equilibrium with the laboratory conditions which may also affect vapour absorption/diffusion of biopolymer stabilised specimens.

### 4.4.2.2. Soil water retention curve

A soil water retention curve is the most appropriate way to present the functional relationship between soil suction and water content (Nuth and Laloui, 2008). Suction measurements during strength tests as presented in Chapter 3 indicate that the biopolymers affect soil water retention properties of the stabilised soil. In the past, very few studies have attempted to understand the effect of biopolymers on soil water retention. Zhao(2014) and Cao et al.,(2017) using a Tempe cell measured soil water retention curves (SWRCs) for poorly graded sand initially saturated with water and biopolymer solutions. It was noted that the suction of sand treated with xanthan solution at 2 g/l concentration was higher than that of unamended sand. Tran et al.,(2017) using capillary rise open tube method found difficulty in estimating the wetting SWRC of xanthan gum stabilised sand, due to the long periods required for the material to come to equilibrium during the tests. It is evident from these two studies that biopolymers affect soil water retention properties and it is important to determine SWRCs for biopolymer stabilised earthen construction materials to understand the effect of biopolymer on soil suction, water content and potentially relate it to its strength.

There are reported studies which have attempted to determine SWRCs of soil used for manufacturing earthen construction material (Bui et al., 2014; Beckett et al., 2015; Gerard et al., 2015; Beckett et al., 2017). Gerard et al.,(2015) arrived at retention curves for unstabilised rammed earthen material which was helpful for developing a unified failure criterion based on Bishop's effective framework to predict the strength of the material. Beckett et al.,(2015) studied the effect of a flocculating agent on two soil mixes (used for rammed earth construction) by determining SWRCs for both untreated and treated soil mixes. It was noted that the addition of flocculating agents increased the residual suction and residual degree of saturation of the treated material. Later, based on the water retention properties developed for untreated soil mixes, Beckett et al.,(2017) characterised the strength of rammed earth material through an extended Mohr-Coulomb theory. From this discussion, it is evident that recent past studies have used SWRCs to characterise the mechanical behaviour of earthen construction material is essential.

In the present investigation, soil water retention curves are expressed in terms of total suction and gravimetric water content. SWRCs for all the combinations considered are plotted for total suction and water content readings obtained until the end of second phase of drying. Figures 4.7, 4.8 and 4.9 present the SWRCs for unamended, guar gum and xanthan gum stabilised soil mixes respectively. SWRCs are plotted for all three replicates specimens tested. In each of the plots, the experimental data was fitted as per the fitting parameters recommended by Fredlund and Xing (1994). Though the fitting parameters recommended by Fredlund and Xing (1994) are primarily used for volumetric water content or degree of saturation, its use is

---

## Chapter 4. Geotechnical Characterisation

also recommended for fitting the data in terms of gravimetric water content (Fredlund et al., 2001). SWRC in terms of gravimetric water content is given below (Fredlund and Xing, 1994; Wijaya and Leong, 2016),

$$w = w_{sat} \frac{C(s)}{\{\ln [\exp(1) + (\frac{s}{a})^n]\}^m} \quad (4.2)$$

$$C(s) = 1 - \frac{\ln\left(1 + \frac{s}{\Psi_r}\right)}{\ln\left(1 + \frac{10^9}{\Psi_r}\right)} \quad (4.3)$$

where,

$w_{sat}$  is the saturated gravimetric content

$s$  is the total suction

$C(s)$  is a correction function which is given by Equation 4.3

$\Psi_r$  is residual total suction

$a$ ,  $m$  and  $n$  are the curve fitting parameter

The fitting parameter namely,  $a$  is related to the air-entry value, larger the value of  $a$ , larger is the air-entry value. The parameter  $m$  is related to the asymmetry of the model and  $n$ , is related to pore size distribution. Larger the value of  $n$ , steeper is the soil water retention curve which suggests the soil has uniform pore sizes.

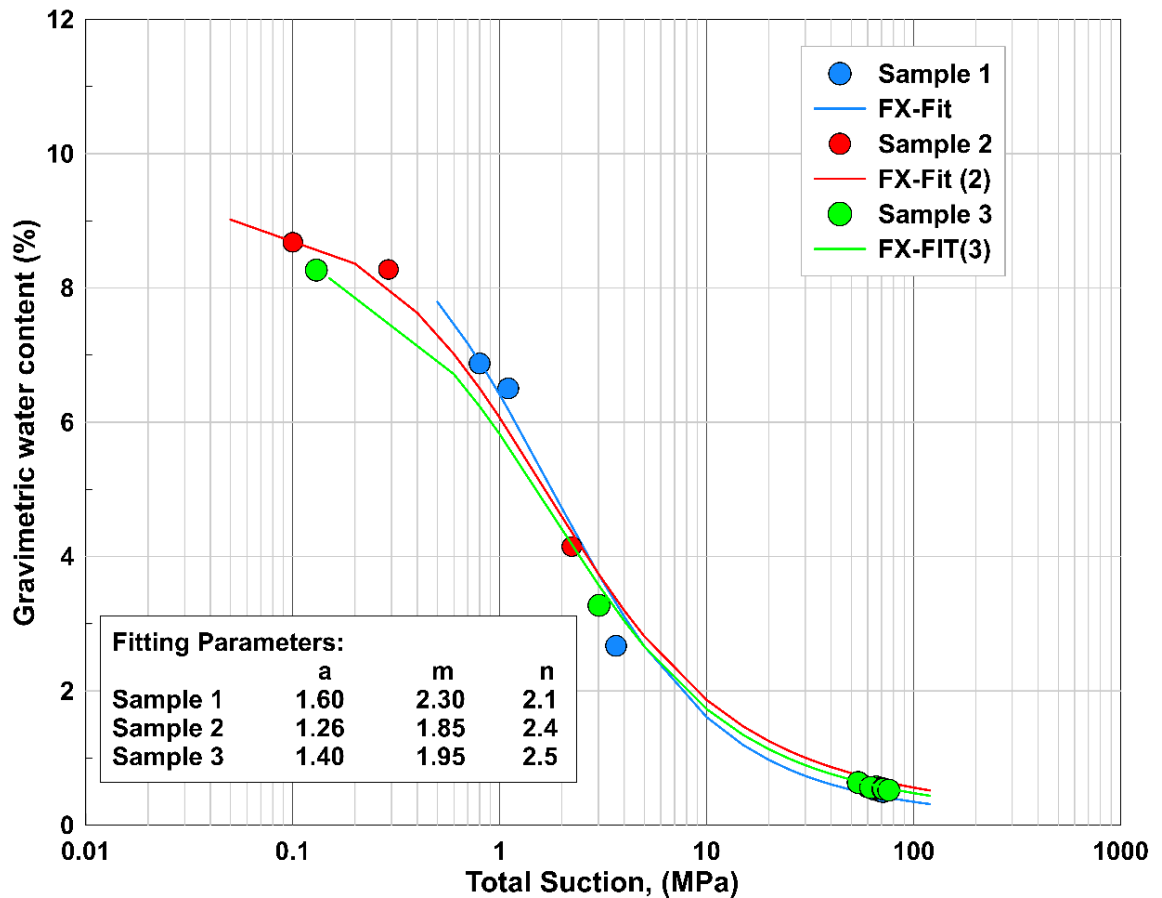

Figure 4.7. Soil water retention curve of unamended soil specimen

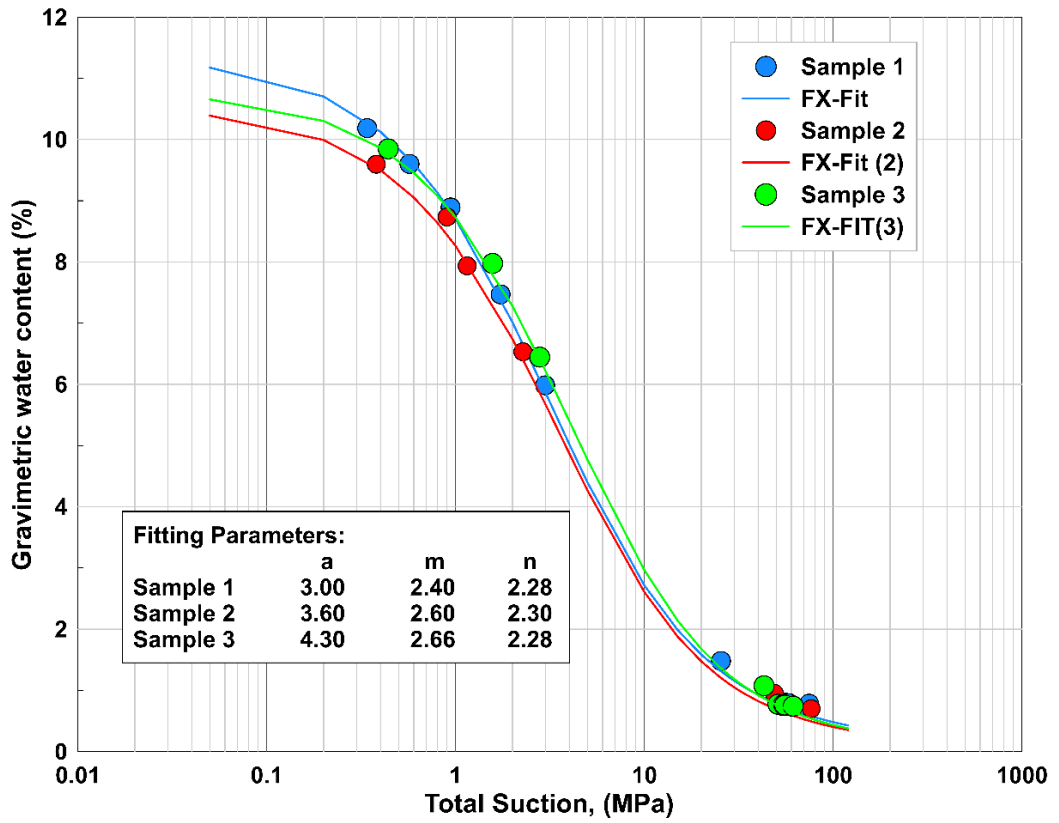

Figure 4.8. Soil water retention curve of guar gum stabilised soil specimen

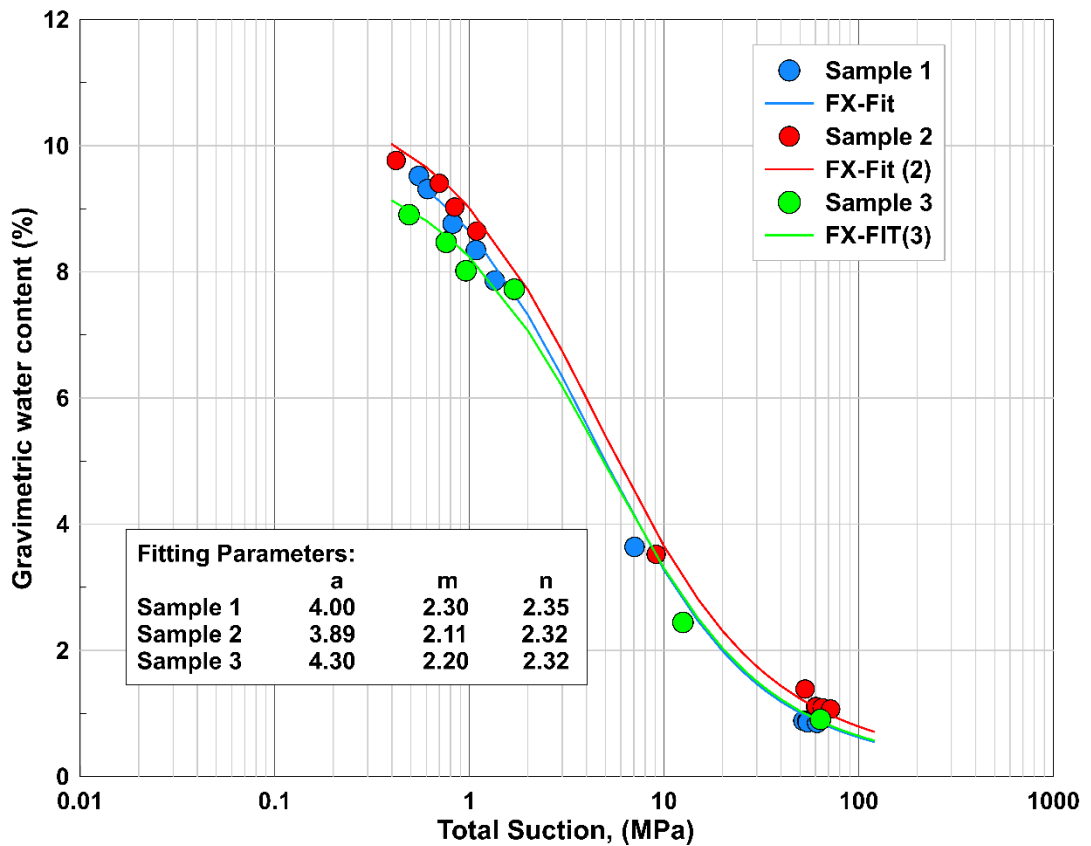

Figure 4.9. Soil water retention curve of xanthan gum stabilised soil specimen

## Chapter 4. Geotechnical Characterisation

The SWRC for all combinations shows, the fitted suction is in the range of 0.5 – 120 MPa, while the experimentally determined suction is in the range of 0.5 – 65 MPa. For each combination, the SWRC was determined for three specimens and it can be observed that the curves for all specimens are consistent. In order to compare the water retention properties of unamended, guar gum and xanthan gum stabilised specimens, SWRCs of each combination were plotted together in Figure 4.10. It can be observed from Figure 4.10, for the range of water contents, the suction values observed by the biopolymer stabilised soil specimens are higher than unamended ones indicating that during the initial stages of biopolymer stabilisation when the hydrogels are predominantly in “rubbery” state contributes in soil suction. Even at high suctions, the amount of water retained by xanthan gum stabilised specimens are higher than the other two combinations. The effect of biopolymer stabilisation is evident through increased value of fitting parameter,  $a$ . With the addition of biopolymer, the absorptive capacity of the stabilised soil mix may have increased, which would have increased the air entry value. Between biopolymers, the effect of xanthan gum on  $a$  is higher than that of guar gum. With the changes in fitting parameter,  $n$  it appears that for the biopolymer stabilised specimens there would be variation in its void size distribution.

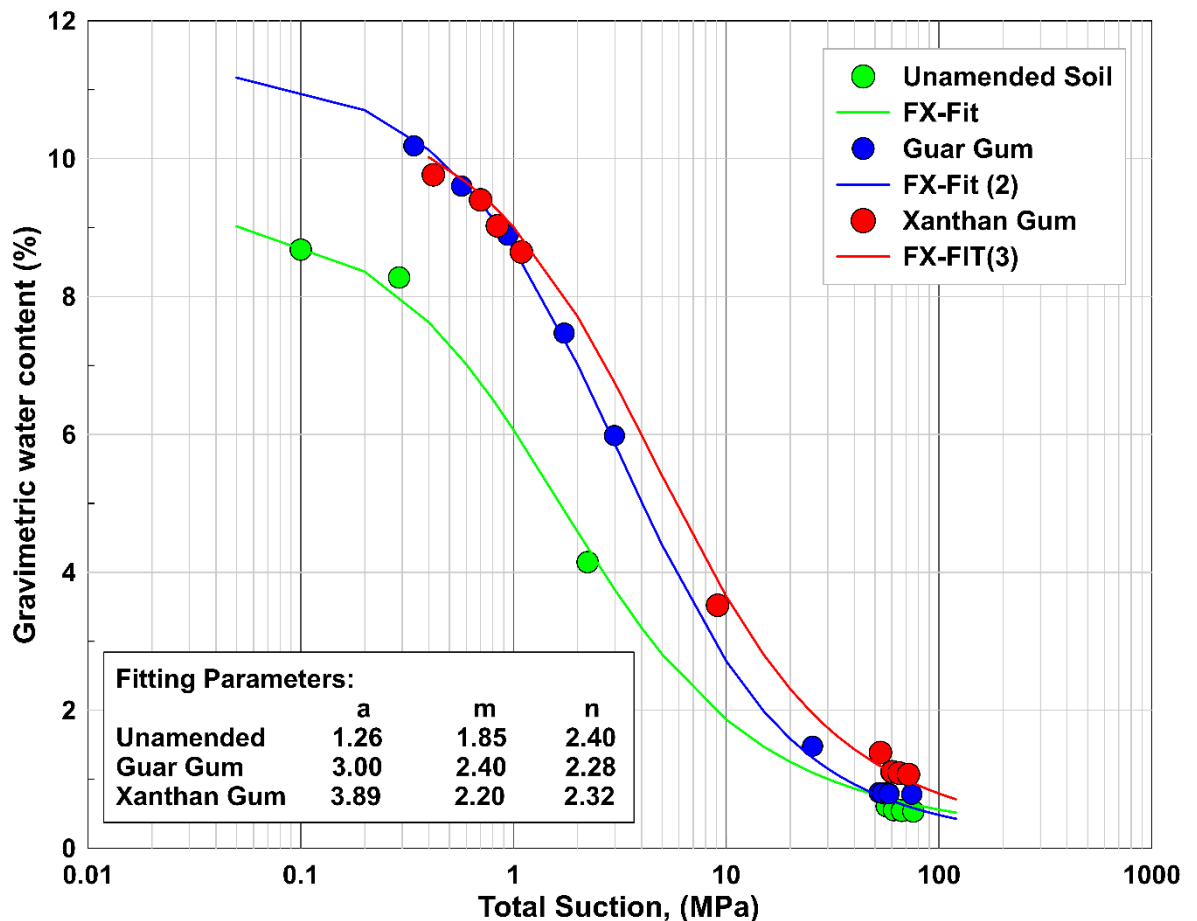

Figure 4.10. Comparison of soil water retention curve for all combinations

4.4.2.3. Scanning curve

An earthen construction material in service may either absorb or diffuse water from its surroundings when exposed to ambient conditions. The variations in ambient conditions will affect soil suction and corresponding water content. These conditions primarily reflect the water retention properties of soil in residual conditions of SWRC. In residual conditions, the pore water is primarily held as absorbed water on clay particles and to achieve this condition high suction is required (McQueen and Miller, 1974). The change in residual water content of the soil primarily occurs due to vapour diffusion (Hillel, 1980). On the other hand, wetting of the soil occurs through vapour absorption. The variations of ambient conditions which affect soil suction and water content can be related to scanning curves of SWRCs. As discussed in Chapter 2, when a soil on a wetting path of SWRC is made to dry midway, it follows a flatter drying curve known as scanning curve until the primary SWRC curve is reached (See Figure 2.15). Similarly, when the soil is on a drying path of SWRC and made to wet midway, it follows a flatter wetting curve until it reaches the primary wetting SWRC. In the present study, the soil specimens were left to dry under ambient conditions to emulate the in-situ conditions of an earthen construction material. It can be observed from the time versus suction graphs presented in Section 4.4.2.1, that when the soil specimens are in the residual zone, there are variations in measured total suction and water content readings. These variations can be expressed as scanning curves. The scanning curves for unamended, guar gum and xanthan gum stabilised soils are presented in Figures 4.11, 4.12 and 4.13 respectively.

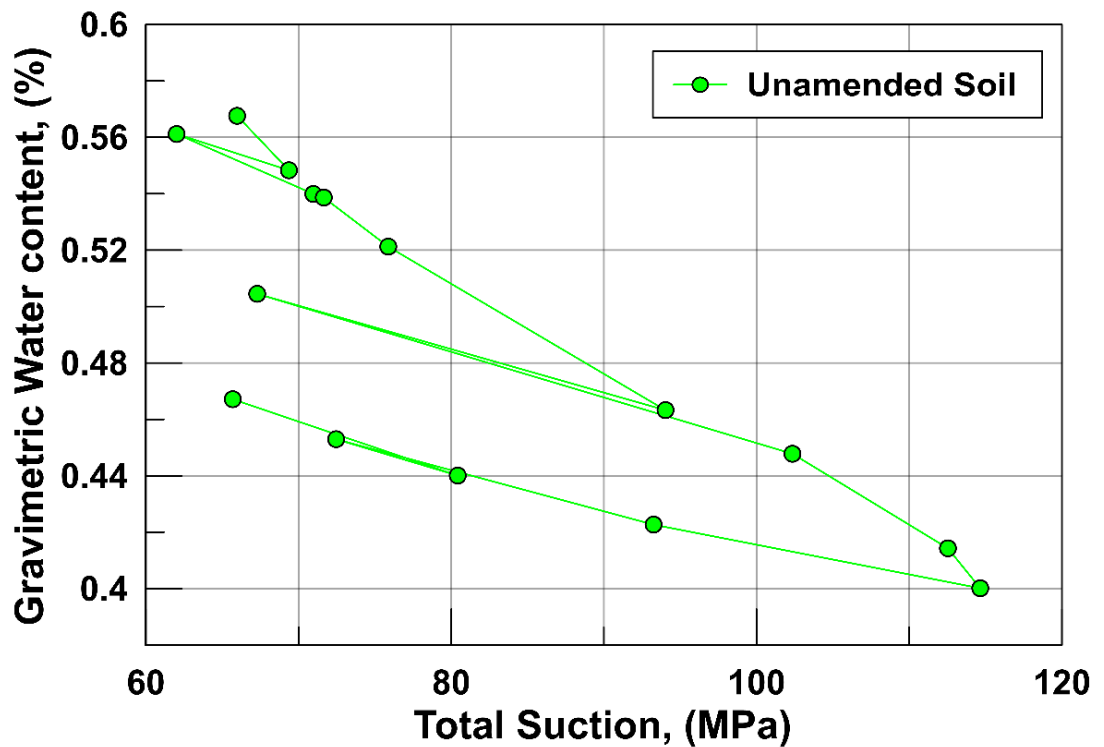

Figure 4.11. Total suction versus gravimetric water content of unamended soil in residual condition

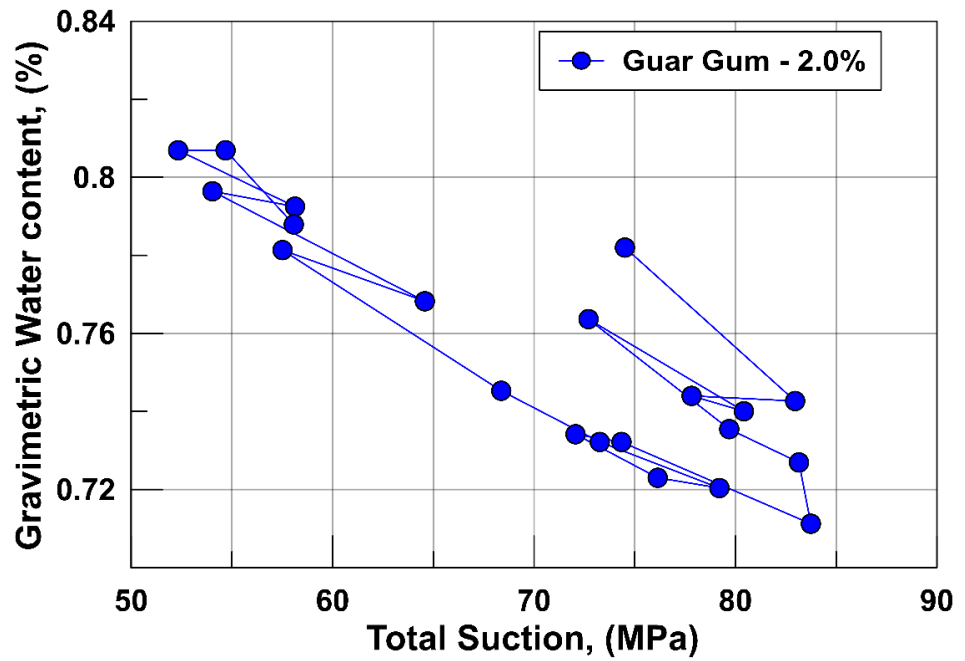

Figure 4.12. Total suction versus gravimetric water content of guar gum stabilised soil in residual condition

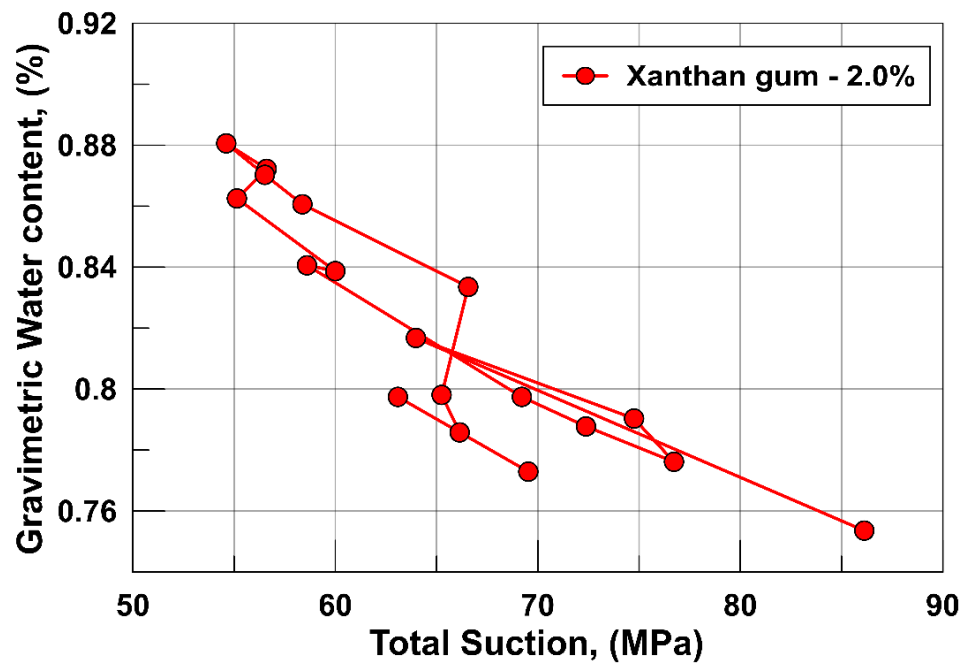

Figure 4.13. Total suction versus gravimetric water content of xanthan gum stabilised soil in residual condition

From Figure 4.11, it can be observed that for unamended soil, as soil dries under ambient conditions, total suction increases and water content decreases. Subsequent variation in ambient conditions, which causes soil to absorb or diffuse water create intermediate scanning curves which are flatter than the primary curve. This behaviour matches with the earlier

description of the scanning curve typically observed in unsaturated soils. In the case of biopolymer stabilised soils, the behaviour of both guar and xanthan gum stabilised specimens are atypical to that of unamended soil. From Figure 4.12 and 4.13, it can be observed that in general stabilised soils hold less water at high suctions, however, drying or wetting caused due to changes in humidity does not lead to intermediate scanning curves but to apparently random variations of suction and water content. It can be observed that for a given water content, two or more different suctions are noted. These random variations between total suction and water content may have been caused due to the evolution of hydrogels which may have been further affected by changes in ambient conditions. As noted by Ayeldeen et al.,(2016), hydrogels formed due to the interaction of biopolymer, water and soil particles undergo significant changes in shape, size and state with aging. Hence, during the initial stages of application, the hydrogel formations within the soil specimen may be thick and rubbery which with time may change to thin glassy structures (Eichler et al., 1997; Ayeldeen et al., 2016). These variations of hydrogel morphology may affect the soil pore size distribution which is directly linked with soil water retention properties (Fredlund et al., 2006). Further, the vapour absorption and diffusion of hydrogels is affected by its state, temperature and humidity (Kocherbitov et al., 2010; Chen et al., 2019). Hence, the random variations of total suction and water content for biopolymer stabilised specimens in residual conditions may be attributed to the variation in ambient conditions coupled with changes in hydrogel morphology.

## 4.5 Constant water content triaxial tests

### 4.5.1 Testing methodology

In parallel to suction tests, constant water content triaxial tests for cylindrical specimens using the same soil used for preparing suction specimens were undertaken. In this type of triaxial test, the water content of the specimen remains constant throughout the test although the tests are not “undrained” in the conventional soil mechanics sense. With triaxial tests, one can get an insight which component of the shear strength contributes to the strength of the earthen construction material (i.e. cohesion or friction). Also, results from triaxial tests might help one to understand the stabilising mechanisms involved in biopolymer stabilisation. In the past, many studies have understood the performance of different earthen construction materials using this approach (Araki et al., 2011; Cheah et al., 2012; El-Nabouch et al., 2018). Adopting similar approach of using triaxial tests, the stabilising mechanisms of biopolymer stabilised earthen construction materials which contribute to strength gain is investigated in this section.

In practice, an earthen construction material is allowed to dry under ambient conditions to gain strength and it is at very low water content during its service. It is appropriate to study the performance of these materials from its inception to service condition under these conditions for their true assessment. This is true even for biopolymer stabilised earthen construction materials, considering much of the strength gain occurs within seven days of curing (as seen

## Chapter 4. Geotechnical Characterisation

---

from strength test results in previous chapter). In order to understand the stabilising mechanisms of biopolymer stabilised earthen construction from its inception under ambient conditions, this investigation was considered to be appropriate.

For the triaxial tests, cylindrical specimens of 38 mm diameter and 76 mm height were prepared in accordance to the procedure described in Section [3.3.2.1](#). Unamended, guar and xanthan gum stabilised cylindrical specimens were prepared for this investigation. The stabiliser content for biopolymer stabilised specimens was maintained at 2.0% of dry soil mass. After preparation, the cylindrical specimens were left to cure under similar conditions as that of the suction test specimens. Samples were tested at designated curing periods of 1, 4, 7, 10, 14 and 28 days. Constant water content triaxial tests were conducted as per the procedure described in BS 1377-7 (1990).

On the day of testing, the dimensions and mass of the cylindrical specimen was noted. The specimens were then fitted inside a single wall triaxial cell and sheared for different confining pressures using TRITECH 50 kN rig. Typical sample setup for triaxial tests is presented in Figure 4.14. For this investigation three confining pressures 100, 200 and 300 kPa were chosen. After the application of the confining pressure the specimen was then sheared until failure. Similar to the unconfined compressive tests, the displacement rate was maintained at 0.5 mm/min. Loads and axial displacements were recorded manually. After the completion of the test, the specimen was removed from the triaxial cell and visually examined to check the failure pattern. Some portion of the soil from the specimen was collected to measure the water contents, while another portion was collected to measure total suction using the WP4c dewpoint potentiometer. Unlike other unsaturated triaxial tests where the measurement of suction is done during the test, in this investigation, suction measurement was done only after the completion of the test primarily because of the specimen status. As discussed previously, it can be expected that the specimens which are left to dry under ambient conditions to have high suctions in the range of 4 – 100 MPa. In this condition, the most feasible option is to determine suction after the completion of the test.



Figure 4.14. Typical setup for triaxial test

4.5.2 Stress – strain relationship

Figures 4.15, 4.16 and 4.17 respectively are deviator stress/strain plots recorded during the triaxial tests for unamended, guar gum and xanthan gum stabilised soil specimens. Stiffness of unamended soil specimens increases as they dry, and once they reach an equilibrium with ambient conditions (within 7 days), the observed stiffness tends to remain constant for subsequent curing periods. Peak stresses of the specimen increase with higher confining pressures, while stiffness remain unaffected.

On viewing the stress/strain plots for guar and xanthan gum stabilised specimens (Figure 4.16 and 4.17), the effect of stabilisation seems to be apparent. At 1-day curing, beyond peak stress, the specimens sustained residual stresses with large plastic deformations (Fig 4.16a and Fig 4.17a). These deformations of the specimen may be attributed to the physical state of the hydrogels. At early stages of stabilisation, the hydrogels with higher absorbed water are essentially thick and in a rubbery state (Ayeldeen et al., 2016). In this state, the hydrogels within the specimen may not take up additional stresses after reaching peak stress, but may still keep the soil particles bonded through plastic hydrogels resulting in large deformations. However, this state is short-lived, as the soil specimens dry, the ductile behaviour of specimen transforms to semi-brittle at 4-day curing, while it is brittle after 7 days. During this transformation, the hydrogels start to shrink and change to glassy state having higher stiffness (Eichler et al., 1997). This transformation is reflected as an appreciable increase in peak stresses and soil modulus for both guar and xanthan gum stabilised specimens after 7 days of curing. The change in stress-strain behaviour after 7 days and until 28 days seems to be minimal for both guar and xanthan gum stabilised specimens. Under similar conditions of testing, between biopolymers, it appears guar gum stabilised specimens have higher peak stresses while xanthan gum stabilised specimens have higher stiffness. In comparison to unamended specimens, biopolymer stabilised specimens have higher peak strength and stiffness at all curing periods. Soil Modulus of soil specimens at different curing are presented in Table 4.1.

Table 4.1. Soil Modulus at different curing periods

| Curing Period<br>(days) | Soil Modulus (MPa) |          |             |
|-------------------------|--------------------|----------|-------------|
|                         | Unamended          | Guar gum | Xanthan Gum |
| 1                       | 96                 | 87       | 75          |
| 4                       | 100                | 166      | 186         |
| 7                       | 105                | 261      | 275         |
| 10                      | 125                | 266      | 289         |
| 14                      | 119                | 260      | 265         |
| 28                      | 132                | 255      | 260         |

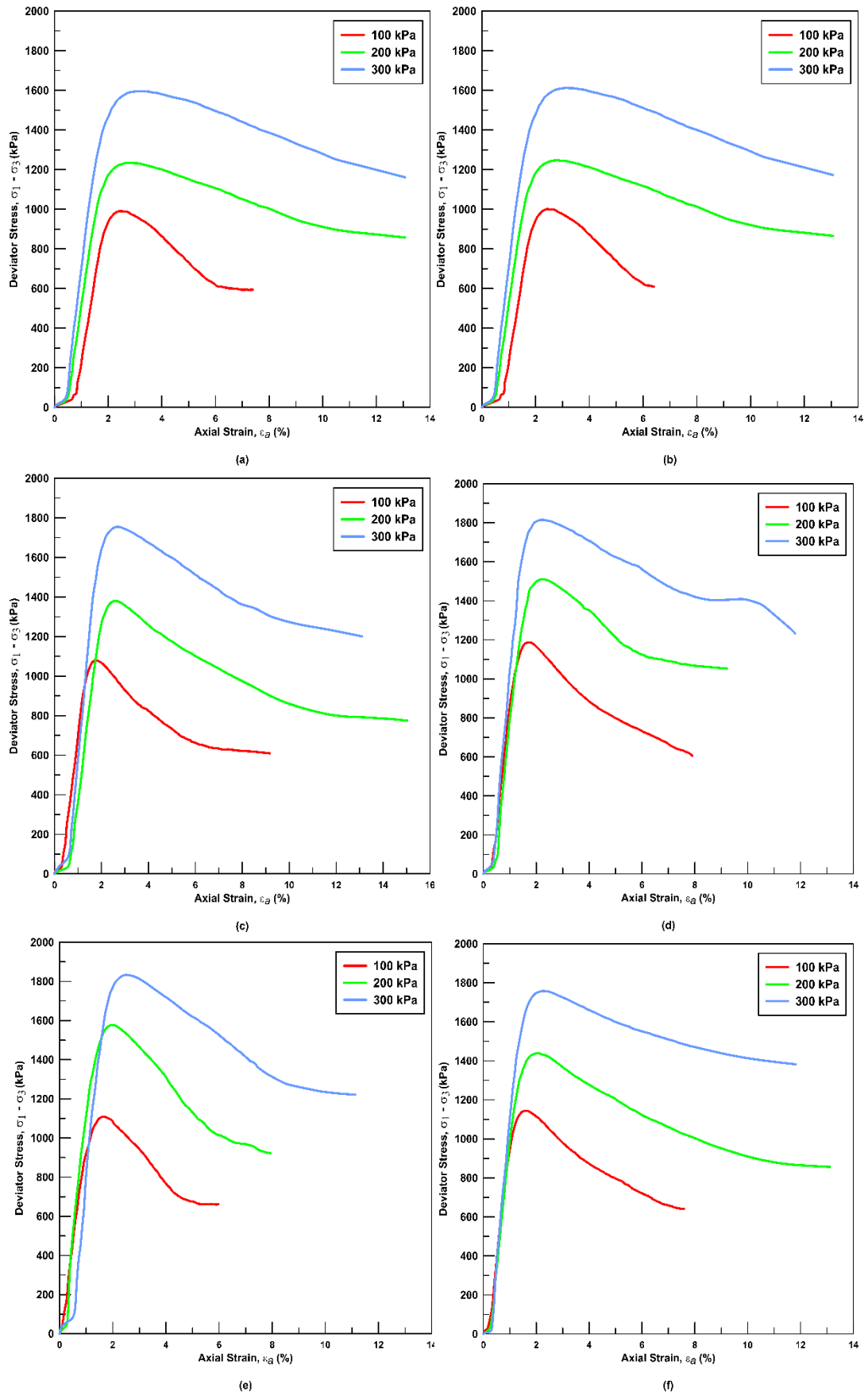

Figure 4.15. Stress-strain plots of unamended soil specimens for curing periods, 1, 4, 7, 10, 14 and 28 days are plotted from a to f respectively.

## Chapter 4. Geotechnical Characterisation

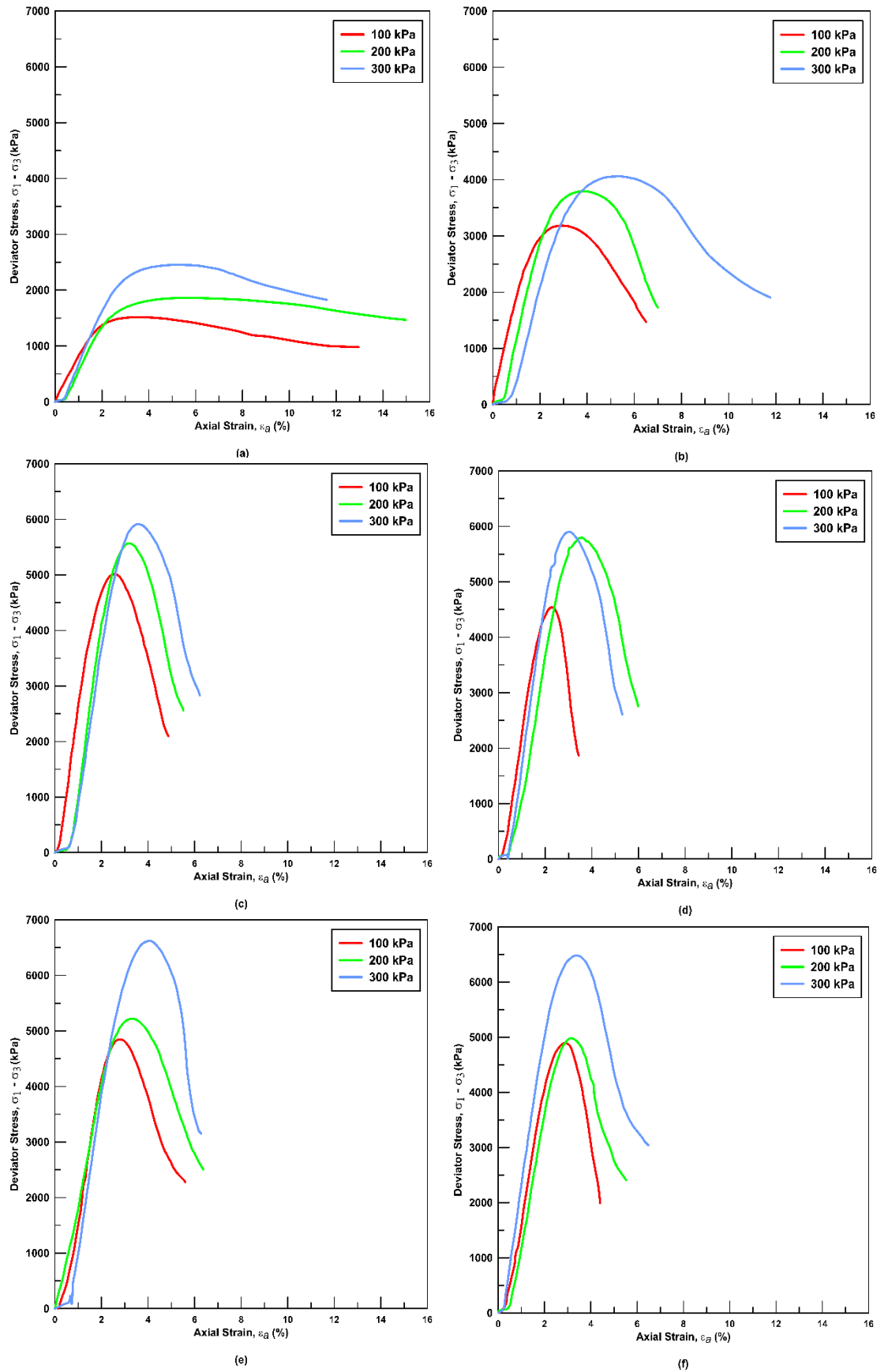

Figure 4.16. Stress-strain plots of guar gum stabilised soil specimens for curing periods, 1, 4, 7, 10, 14 and 28 days are plotted from a to f respectively.

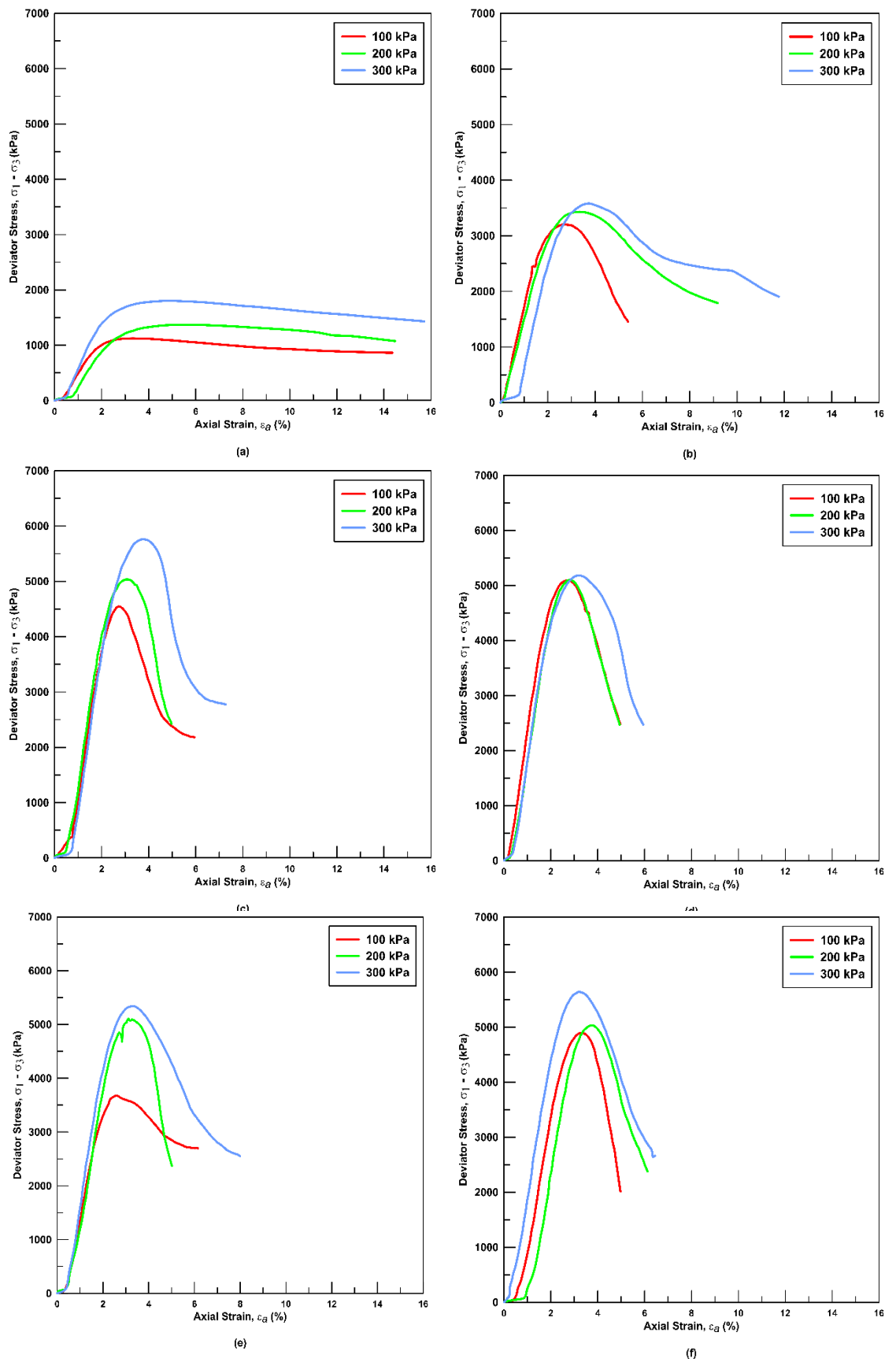

Figure 4.17. Stress-strain plots of xanthan gum stabilised soil specimens for curing periods, 1, 4, 7, 10, 14 and 28 days are plotted from a to f respectively.

### 4.5.3 Determination of shear strength parameters

The two shear strength parameters namely, cohesion  $c$  and angle of internal friction  $\phi$  define the strength characteristics of a soil for given loading and drainage conditions (Terzaghi et al., 1963). Typically, the shear parameters are obtained graphically by constructing a Mohr circle for normal and shear stresses obtained from strength tests. As discussed previously in Section 4.2, this holds good even for unsaturated soils, where EMC failure envelope is arrived by plotting Mohr circles for different suction values which is defined by additional shear parameter related to soil suction  $\phi_b$ . However, in case of biopolymer stabilised soils it was observed from suction tests for a given water content, two or more different suctions were noted. In this condition, characterisation of strength based on EMC criterion may not be possible, as for a given suction two or three sets of Mohr circles would be plotted which may prove erroneous in determining the strength parameters. As an alternative, one can plot  $p - q$  diagram, to derive and compare shear parameters for different soil specimens at the same time (Wood, 1990). In  $p - q$  diagram,  $q$  which is deviator stress is plotted against  $p$  which is mean stress.  $p$  and  $q$  are expressed as follows,

$$p = \frac{1}{3} (\sigma_1 + \sigma_2 + \sigma_3) \quad (4.4)$$

$$q = \sqrt{\frac{(\sigma_1 - \sigma_2)^2 + (\sigma_2 - \sigma_3)^2 + (\sigma_1 - \sigma_3)^2}{2}} \quad (4.5)$$

where,  $\sigma_1$ ,  $\sigma_2$  and  $\sigma_3$  are principal stresses acting along three different axes.

However, in case of triaxial compression  $\sigma_2 = \sigma_3$ . Thus,

$$p = \frac{1}{3} (\sigma_1 + 2\sigma_3) \quad (4.6)$$

$$q = (\sigma_1 - \sigma_3) \quad (4.7)$$

The strength envelope for the soil in terms of  $p$  and  $q$  is expressed as,

$$q = C + (M p) \quad (4.8)$$

where the coefficients  $C$  and  $M$  are respectively the intercept and slope of the failure or strength envelope that defines shear strength of soils at different stresses. These coefficients can be converted into corresponding values of cohesion  $c$  and angle of internal friction  $\phi$  by means of the following equations:

$$M = \frac{6 \sin \phi}{3 - \sin \phi} \rightarrow \sin \phi = \frac{3 M}{6 + M} \quad (4.9)$$

$$C = \frac{6 c \cos \phi}{3 - \sin \phi} \rightarrow c = \frac{(3 - \sin \phi) C}{6 \cos \phi} \quad (4.10)$$

For the triaxial tests conducted, the parameters  $p$  and  $q$  were determined for each specimen tested.  $p - q$  diagrams for unamended, guar and xanthan gum stabilised specimens are presented in Figures 4.18, 4.19 and 4.20 respectively. The shear strength parameters, i.e. cohesion  $c$  and angle of internal friction  $\phi$  were calculated through Equations 4.9 and 4.10 respectively from the coefficients  $C$  and  $M$  obtained from respective  $p - q$  diagrams. The calculated shear strength parameters, total suction and water content values at respective curing periods are presented in Table 4.2, 4.3 and 4.4 for unamended, guar and xanthan gum stabilised specimens respectively.

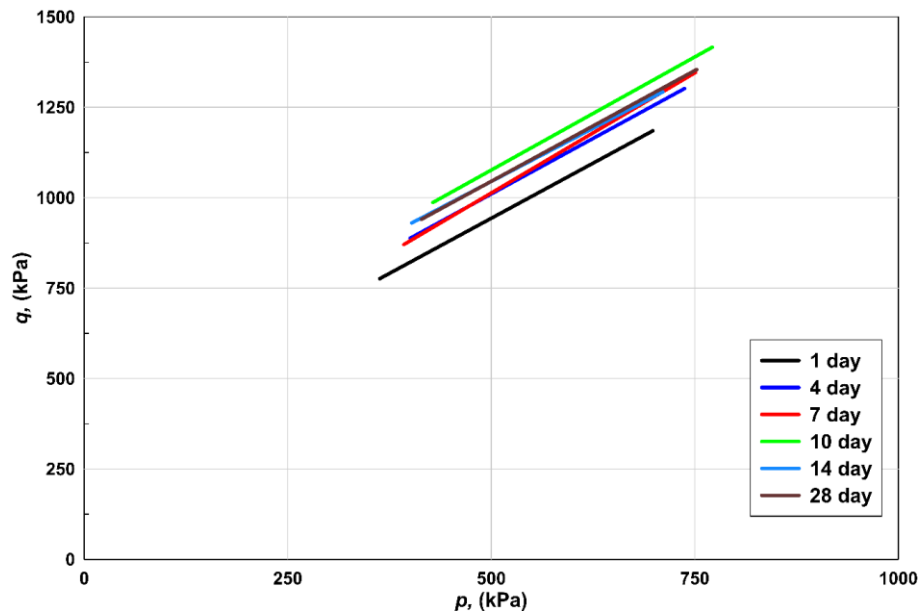

Figure 4.18.  $p - q$  diagram of unamended soil specimens at different curing periods

Table 4.2. Shear strength parameters, total suction and water content values for unamended soil specimens

| Curing Period (days) | Shear Strength Parameters |                       | Total Suction (MPa) | Water Content (%) |
|----------------------|---------------------------|-----------------------|---------------------|-------------------|
|                      | $c$ (kPa)                 | $\phi$ ( $^{\circ}$ ) |                     |                   |
| 1                    | 160                       | 30.4                  | 1.1                 | 4.86              |
| 4                    | 190                       | 30.6                  | 61.4                | 2.82              |
| 7                    | 170                       | 32.9                  | 66.1                | 0.57              |
| 10                   | 210                       | 31.1                  | 75.0                | 0.46              |
| 14                   | 220                       | 30.0                  | 76.3                | 0.40              |
| 28                   | 200                       | 30.5                  | 79.7                | 0.39              |

## Chapter 4. Geotechnical Characterisation

From  $p - q$  diagrams of unamended soil specimens (Figure 4.18), it can be observed that, the stress path of 1-day cured soil specimens is below and separated from other specimens. Having comparatively higher water content, it can be expected that 1-day cured specimens to take lower normal stresses than other specimens. However, once dried, stress paths of soil specimens at different curing periods are grouped together and essentially parallel to each other. The slight variations of shear strength parameters of unamended soil specimens noted at different curing periods may have occurred due to the humidity changes. However, it is to be noted that these changes have not changed the shear strength parameters of unamended soil specimens drastically. It can be concluded that, for unamended soil specimens, the cohesion is about 200 kPa and angle of internal friction to be about  $31^\circ$ .

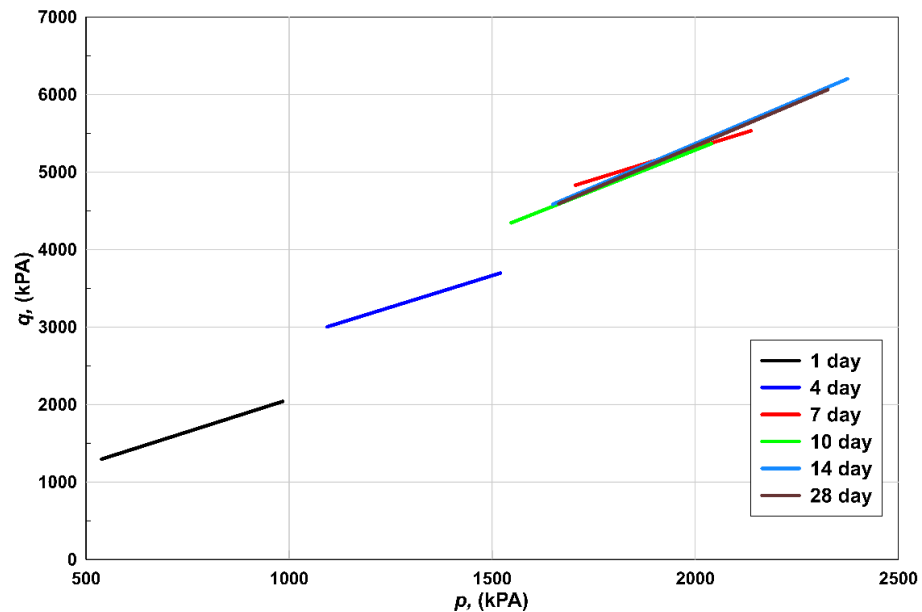

Figure 4.19.  $p$ - $q$  diagram of guar gum stabilised soil specimens at different curing periods

Table 4.3. Shear strength parameters, total suction and water content values of guar gum stabilised soil specimens

| Curing Period (days) | Shear Strength Parameters |                     | Total Suction (MPa) | Water content (%) |
|----------------------|---------------------------|---------------------|---------------------|-------------------|
|                      | $c$ (kPa)                 | $\phi$ ( $^\circ$ ) |                     |                   |
| 1                    | 200                       | 40.7                | 0.7                 | 6.64              |
| 4                    | 620                       | 39.7                | 6.8                 | 2.82              |
| 7                    | 1050                      | 39.7                | 66.2                | 0.70              |
| 10                   | 620                       | 50.3                | 73.2                | 0.72              |
| 14                   | 560                       | 54.3                | 57.6                | 0.40              |
| 28                   | 550                       | 54.4                | 60.4                | 0.72              |

## Chapter 4. Geotechnical Characterisation

For guar gum stabilised soil specimens, it can be observed from the  $p - q$  diagram (Figure 4.19), that the stabilised specimen gain strength rapidly within 7 days of curing. However, after 7 days, the change in strength is not so significant. Between 1 and 7 days of curing, the cohesion of guar gum stabilised specimens rises from 200 kPa to 1050 kPa, while the angle of internal friction is about  $40^\circ$ . Thereafter, the stabilised specimen tends to lose its cohesion with aging, while there is steady increase in angle of internal friction. By the end of 28 days, for the guar gum stabilised specimens the cohesion is about 550 kPa and angle of internal friction is about  $54^\circ$ .

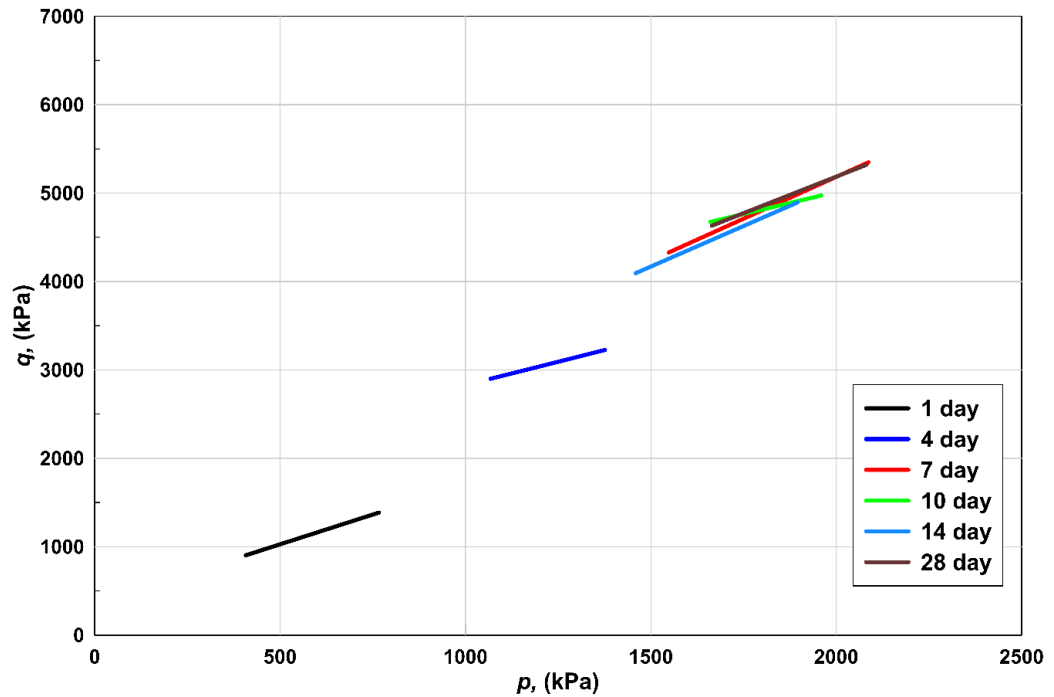

Figure 4.20.  $p$ - $q$  diagram of xanthan gum stabilised soil specimens at different curing periods

Table 4.4. Shear strength parameters, total suction and water content values for xanthan gum stabilised soil specimens

| Curing Period (days) | Shear Strength Parameters |                     | Total Suction (MPa) | Water content (%) |
|----------------------|---------------------------|---------------------|---------------------|-------------------|
|                      | $c$ (kPa)                 | $\phi$ ( $^\circ$ ) |                     |                   |
| 1                    | 350                       | 33.3                | 0.8                 | 7.52              |
| 4                    | 840                       | 26.7                | 7.3                 | 2.95              |
| 7                    | 760                       | 46.0                | 63.9                | 0.86              |
| 10                   | 660                       | 50.3                | 54.5                | 1.00              |
| 14                   | 760                       | 44.5                | 55.6                | 0.95              |
| 28                   | 960                       | 40.3                | 65.0                | 0.87              |

## Chapter 4. Geotechnical Characterisation

---

Similar to guar gum, xanthan gum stabilised specimen gains strength rapidly within 7 days of curing. However, the change of shear strength parameters with aging for xanthan gum is not similar to that of guar gum stabilised specimens. Unlike guar gum, xanthan gum stabilised soil specimen retains its cohesion, while the angle of internal friction decreases with time. By end of 28 days, for the xanthan gum stabilised specimens the cohesion is about 960 kPa and angle of internal friction to be about  $40^\circ$ . Compared to unamended soil specimens, the change in shear strength parameters observed for biopolymer stabilised specimen between curing periods is more significant. As noted in the Chapter 3, the strength of the biopolymer stabilised soils is caused by a combination of hydrogel bonding and soil suction. Hence, the changes observed in shear strength parameters with aging may be linked with the evolution of hydrogel bonding and changes in ambient conditions.

Guar gum is a neutrally charged polysaccharide having numerous hydroxyl ions which would essentially interact with soil particles through hydrogen bonding (Chudzikowski, 1971; Mudgil et al., 2011). With no ionic bonding, the variation in shear strength parameters for guar gum stabilised specimens can be primarily associated with the physical state of the hydrogels. As reported by Ayeldeen et al.,(2016), at early stages of biopolymer stabilisation (~7 days), the hydrogels which bind soil particles are essentially in rubbery state. It can be observed that at 7 days, guar gum specimens have higher water content than unamended soil specimens, however, soil suction is in the similar range, indicating that hydrogels in rubbery state contribute to matric suction and in turn soil cohesion. However, with aging, guar gum stabilised specimens lose cohesion but increase angle of internal friction. This again may be linked with hydrogel state and intrinsic characteristics of the guar gum. As hydrogels transform to a glassy state, they shrink in size but become stiffer (Eichler et al., 1997). In this condition, hydrogels primarily act as a stiff network of interconnected bonds which may increase the effective inter-particle contact area and aid in the frictional component of the shear strength. On the other hand, the hydrogels bond with soil particles through weak hydrogen bonds, in this state, soil suction may be reduced and in turn suction related cohesion. The value of the angle of internal friction, soil suction and water content values between 10 and 28 days seem to support this hypothesis.

Similar to guar gum, during the early stages of curing (~7 days), the hydrogels in xanthan gum stabilised specimens are expected to be in rubbery state which later turns to glassy state. As xanthan gum interacts with clay particles through ionic bonding, the variation of shear strength parameters may not be completely dependent only on the transformation of hydrogels. As an anionic polysaccharide xanthan gum interacts with clay particles through ionic bonding apart from hydrogen bonding and form stable soil agglomerations (Katzbauer, 1998; Garcia-Ochoa et al., 2000; Chen et al., 2013; Chang et al., 2015). Further, Chen et al.,(2013) reports that while forming stable soil agglomerations, the hydrogels formed tend to push apart the soil agglomerations which induce larger void spaces. When xanthan gum interacts with sand particles, they act as a coat across the surface of the sand grain and link it with other sand

grains (Qureshi et al., 2017). In the present study, the engineered soil mix contains both clay and sand particles and when xanthan gum is added to the engineered soil mix, it would have instantly formed ionic bonds with clay particles, while it coats the surface of sand grains. These interactions between xanthan gum, clay, sand and water may lead to formation of stable soil agglomerations. During the early stages of curing (~7 days), soil agglomerations may be linked with each other through long chains of hydrogels. As soil specimens age, the hydrogels start to shrink and may pull these agglomerations towards each other. On compression, individual agglomerations may remain stable due to stronger bonds between the soil particles, while adjacent agglomerations may slide along each other breaking the network of hydrogels. Hence, with aging, the angle of internal friction seems to reduce slightly, while cohesion of the material is still maintained. This explanation is based on the experience gained by working with the biopolymers and the experimental results achieved, however, future studies which can visualise the failure of biopolymer stabilised specimens at micro level would be required to validate it.

### 4.5.4 Strength characteristics of engineered soil mix

In the above strength tests, the soil used to prepare triaxial specimen was similar to that of the soil used to prepare suction test specimens, where an engineered soil mix passing through 2.0 mm sieve was used. In order to understand the effect of biopolymer stabilisation on the actual engineered soil mix which comprises of 20% kaolin, 70% sand and 10% gravel, additional triaxial tests were conducted. In this investigation, cylindrical specimens of 38 mm diameter and 76 mm height with the engineered soil mix were prepared in accordance to the procedure outlined in Section [3.3.2.1](#). In this investigation, only guar and xanthan gum stabilised cylindrical specimens were tested. The stabiliser content for biopolymer stabilised specimens was maintained at 2.0% of dry soil mass. The sample preparation, testing procedure and curing conditions were similar to that mentioned in Section [4.5.1](#). However, in this investigation, six confining pressures, 50, 100, 150, 200, 250 and 300 kPa were chosen and cylindrical specimens were tested at 1, 7 and 28 days after its preparation. Figures 4.21 and 4.22 present stress/strain plots and typical failure pattern at different curing periods for guar and xanthan gum stabilised specimens respectively. For both biopolymers, the specimens at 1-day curing have lower peak stresses and undergo large deformation. The ductile behaviour of specimens for both biopolymers are due the rubbery state of hydrogels as observed previously in the suction tests. At 7-day curing period, when the hydrogels are in the middle of transformation from rubbery state to glassy state, this transformation is reflected as appreciable increase in peak stresses and stiffness for both guar and xanthan gum stabilised specimens. At the end of 28 days, when the hydrogels are predominantly in glassy state, the specimens tend to have brittle failure with well-defined failure surface. These mechanical behaviours of the specimens are similar to the one noted previously in suction tests. Shear strength parameters for biopolymer stabilised specimens at different curing periods were derived from  $p - q$  diagrams.

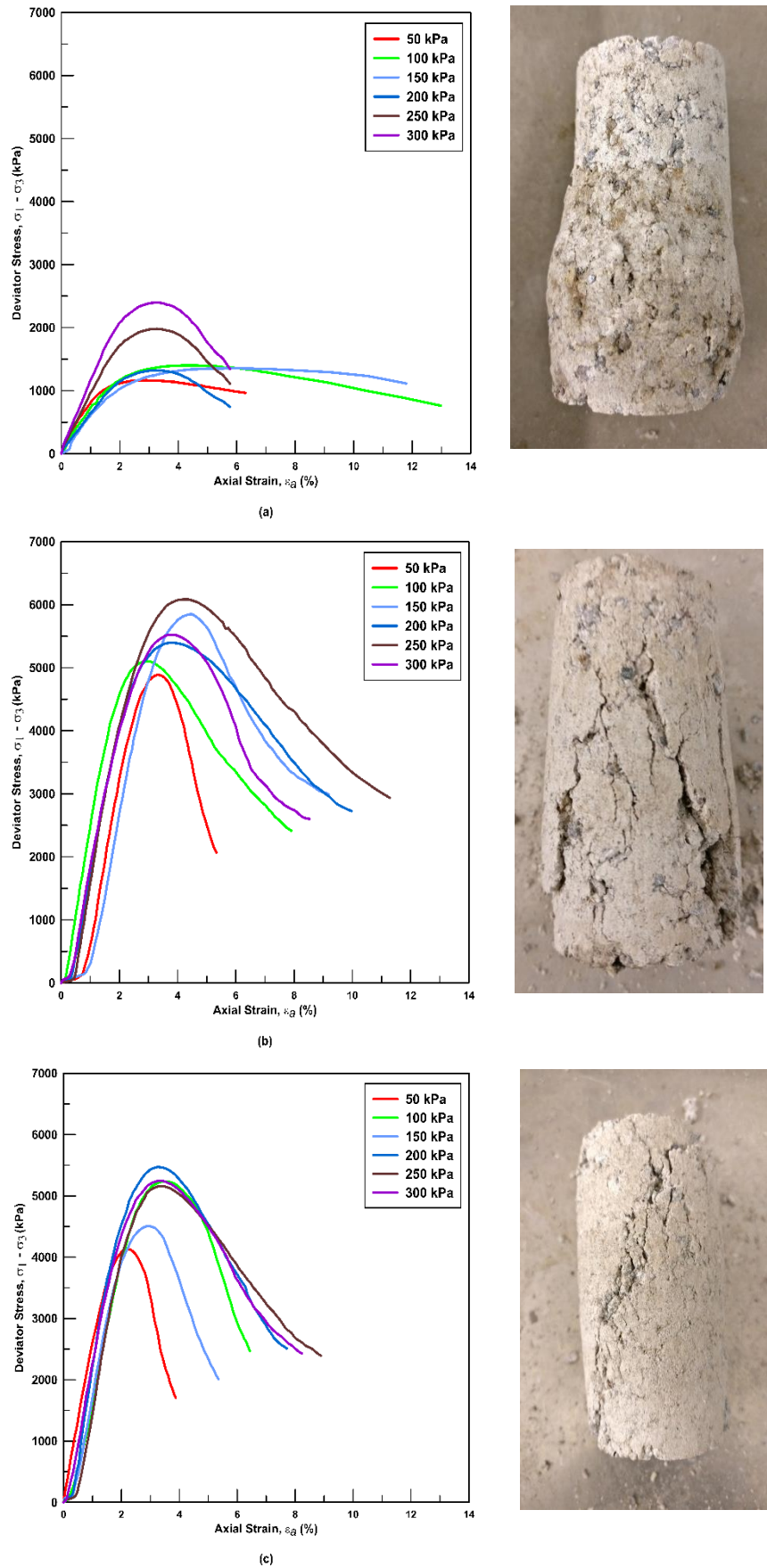

Figure 4.21. Deviator stress/strain plots and typical failure pattern of guar gum stabilised soil specimens (a) 1 day, (b) 7 days, (c) 28 days

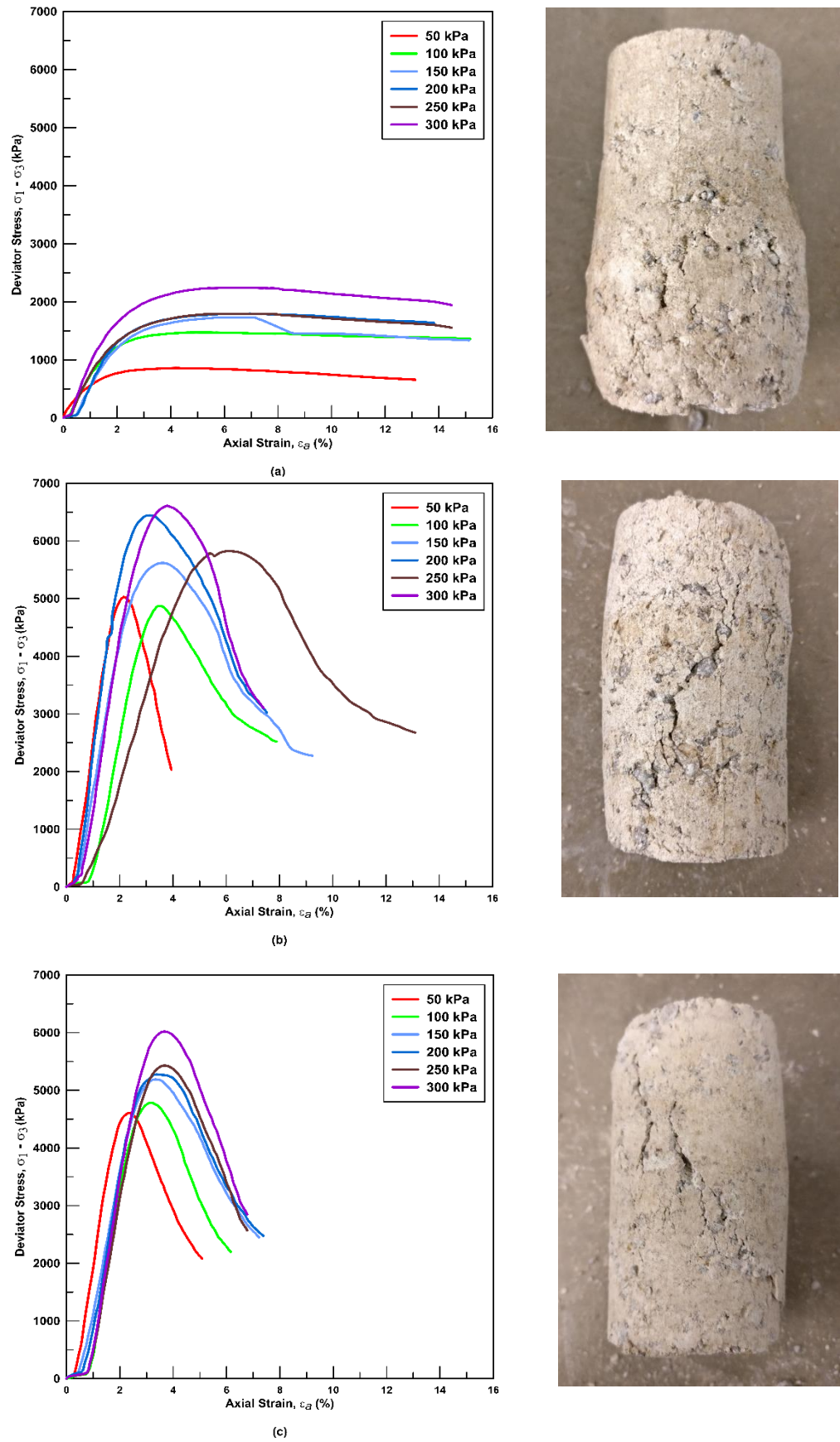

Figure 4.22. Deviator stress/strain plots and typical failure pattern of xanthan gum stabilised soil specimens (a) 1 day, (b) 7 days, (c) 28 days

## Chapter 4. Geotechnical Characterisation

Figures 4.23 and 4.24 present  $p - q$  diagrams for guar and xanthan gum stabilised specimens respectively. Table 4.5 shows the shear strength parameters for both guar and xanthan gum stabilised soil specimens at different curing periods. It can be observed that, for both biopolymers the trend in which the shear strength parameters change between different curing periods is reminiscent to the changes discussed previously. It can be concluded that though both guar and xanthan gum depend on hydrogels to provide stabilisation, the nature in which the stabilisation occur vary with the intrinsic chemical properties of the biopolymer. At the end of 28 days, the hydrogels formed by guar gum essentially act as network of interconnected bonds which may increase the effective inter-particle contact area and aid in increasing the frictional component of the shear strength. The cohesion of the guar stabilised specimens was 703 kPa and the angle of internal friction was  $48^\circ$ . In case of xanthan gum, due to additional ionic bonding capability it improves cohesion between the soil particles and stable soil agglomerations. At end of 28 days, the cohesion for xanthan gum stabilised specimens was 1000 kPa and the angle of internal friction was  $39^\circ$ .

Table 4.5. Shear strength parameters, total suction and water content values for xanthan gum stabilised soil specimens

| Curing Period<br>(days) | Guar gum  |                     | Xanthan gum |                     |
|-------------------------|-----------|---------------------|-------------|---------------------|
|                         | $c$ (kPa) | $\phi$ ( $^\circ$ ) | $c$ (kPa)   | $\phi$ ( $^\circ$ ) |
| 1                       | 164       | 41.2                | 150         | 41.6                |
| 7                       | 924       | 44.2                | 770         | 49.8                |
| 28                      | 703       | 48.0                | 1000        | 39.3                |

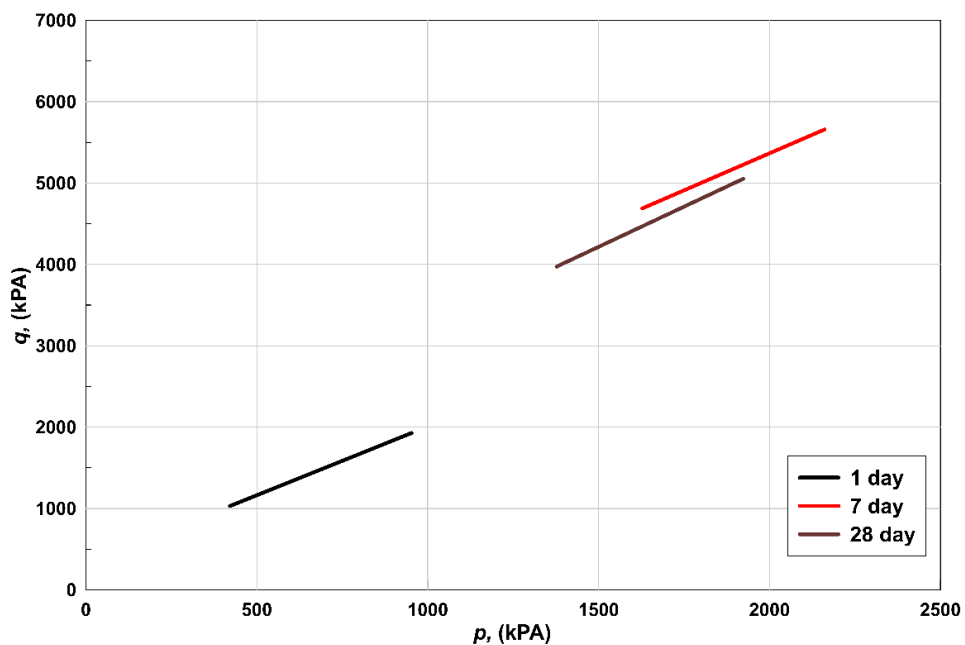

Figure 4.23.  $p - q$  diagram of guar gum stabilised soil specimens at different curing periods

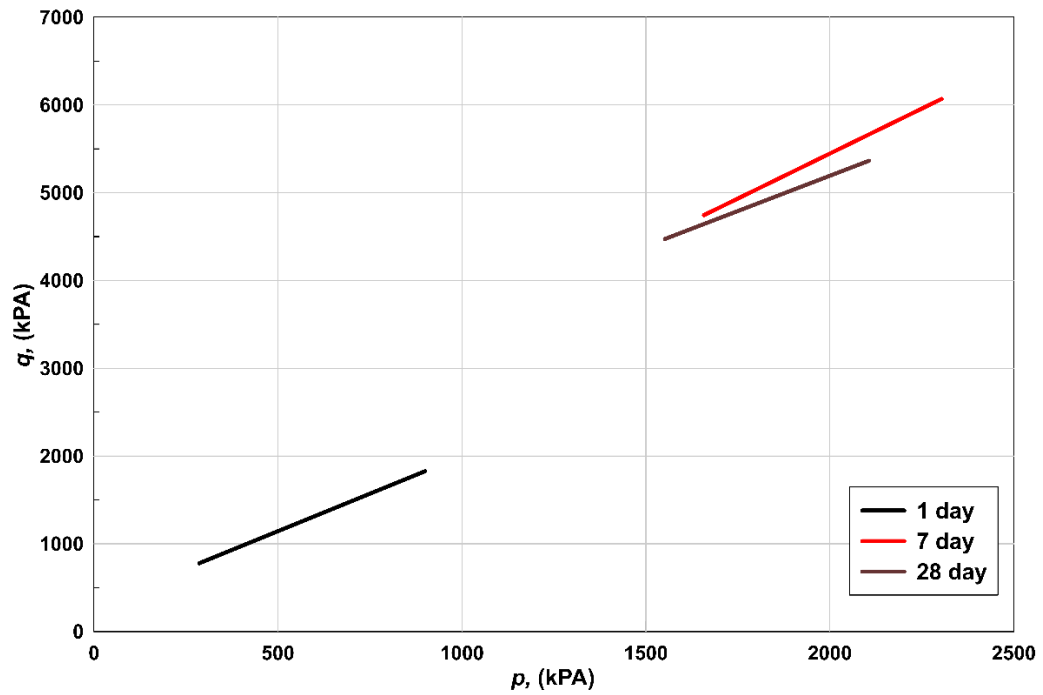

Figure 4.24. p-q diagram of xanthan gum stabilised soil specimens at different curing periods

Table 4.6. Comparison of shear strength parameters of different earthen construction materials from literature and data from present study.

| Study                     | Sample     | Shear test type | Shear Parameters |                       |
|---------------------------|------------|-----------------|------------------|-----------------------|
|                           |            |                 | c (kPa)          | $\phi$ ( $^{\circ}$ ) |
| Araki et al., (2011)      | USRE       | Tri-axial       | 626              | 49                    |
| Cheah et al., (2012)      | CSRE       | CW – Triaxial   | 724              | 48                    |
| Corbin and Augarde (2015) | USRE       | Shear box       | 55-80            | 23-65                 |
| Gerard et al., (2015)     | USRE       | CU – Triaxial   | 6.2              | 36.5                  |
| Beckett et al., (2017)    | USRE       | UC              | 150              | 39.7                  |
| Present study             | Unamended* |                 | 200              | 30.5                  |
|                           | GG 2.0%    | CW – Triaxial   | 703              | 48.0                  |
|                           | XG 2.0%    |                 | 1000             | 39.3                  |

\*For unamended specimens, the shear strength parameters are for the specimens prepared with engineered soil mix passing through 2.0mm sieve.

Table 4.6 compares the shear strength parameters of specimens from the present study with literature data. Though in geotechnical engineering, the strength of the soil is dealt in terms of shear strength parameters, characterisation of earthen construction materials by many international standards is mostly done in terms of unconfined compressive strength (Schroeder,

2016). Apart from the guideline recommended by Middleton (1992) that the minimum angle of friction of rammed earth material should be  $27^{\circ}$ , no other technical document delineates the requirements of earthen construction materials in terms of shear strength parameters. However, in the recent past, attempts have been made to characterise earthen construction materials in terms of geotechnical engineering (Jaquin et al., 2009; Cheah et al., 2012; Gerard et al., 2015; Beckett et al., 2017). Few of these studies have however attempted to determine the shear strength parameters through different types of shear tests. Shear strength parameters presented in Table 4.6 are from studies where the soil gradation and curing conditions are similar to the conditions incorporated in the present study. Having cohesion of 200 kPa and angle of internal friction of  $30^{\circ}$ , the shear strength parameters of unamended soil are lower in comparison to the literature reported data. However, the shear strength parameters of biopolymer stabilised earthen construction material are higher than the literature reported data and comparable to the shear strength parameters of cement stabilised rammed earth materials as presented by Cheah et al.,(2012).

### 4.6. Macrostructural investigation using X-ray computed tomography

The drying of soil and hydrogel transformation may have an effect on the pore structure of biopolymer stabilised soils. The differences in the fitting parameter,  $n$  used in the construction of SWRCs of unamended, guar gum and xanthan gum stabilised specimens certainly suggest that there are variations in void size distribution between specimens. Visual inspection of XRCT scans of biopolymer stabilised specimens between 7- and 28-days curing periods presented in Chapter 3 also indicate that the biopolymers have an effect on pore structure. As a continuation to this investigation, further XRCT scanning was taken up to understand the effect of biopolymers on macrostructure at different curing periods. The results obtained from the XRCT scans were compared with the scans of unamended specimens to understand the effect of biopolymer stabilisation. Considering the wide range of particle sizes used in earthen construction material (as in case of the engineered soil mix used in the present study), macrostructural study using X-Ray computed tomography was considered more appropriate as the XRCT scans are obtained from large sized samples and are more representative than other techniques (Augarde, 2015).

#### 4.6.1 Specimen Preparation

Ketcham and Carlson (2001) suggest that the specimens for X-RCT scanning should be at least 1000 times larger than the desired resolution. It was noted in the preliminary studies conducted in Chapter 3, that the resolution of about  $8.5 \mu\text{m}$  was sufficient to obtain good quality scans for the earthen construction material. Similar resolution was adopted by Beckett et al., (2013) to scan for earthen construction materials with similar soil gradation. Corresponding to the

## Chapter 4. Geotechnical Characterisation

---

resolution of 8.5  $\mu\text{m}$  resolution, the minimum thickness of the specimen comes to 8.5 mm thick, which is about the size of the suction specimens considered in suction tests in Section 4.4. Hence for this investigation, specimens of 35 mm diameter and 8 mm thickness were considered. Test specimens were prepared for unamended, guar and xanthan gum stabilised specimens. The biopolymer content for the stabilised specimens was maintained at 2.0 % of the dry mass of soil mix. The specimens were prepared and cured in a similar manner as described in Section 4.4.1.

X-RCT scanning was done using XRadia/Zeiss XRM-410 machine based at Durham University XCT service (ZEISS, 2014). Smith (2015) noted that the XRM-410 can perform scans for samples up to 300mm diameter at different resolutions from 1 to 40  $\mu\text{m}$  which is sufficient for obtaining the scans for the test specimens for the required resolution of 8.5  $\mu\text{m}$ . For a given specimen, after 1 day of curing, the sample was scanned in the XRCT machine. For this resolution, a typical scan lasted about 14 -16 hours. After the completion of the scan, the sample was then transferred back to the laboratory to cure. The specimen was scanned again at 7 and 28 days of curing. The raw data obtained from XRM-410 was analysed using Avizo Fire software. As an image processing and analysing software, Avizo contains various modules to edit, view and analyse the raw data. The X-RCT scans were analysed in the form of 2-D slices across the diameter of the sample in Avizo. Roughly 1600 slices were available for analysis per sample. Figure 4.25 presents the steps involved in image processing and analyses using Avizo. Label analysis counts and categorises macropores based on its volume, while the volume fraction analysis obtains the percentage of masked volume to the total volume which is porosity of the specimen.

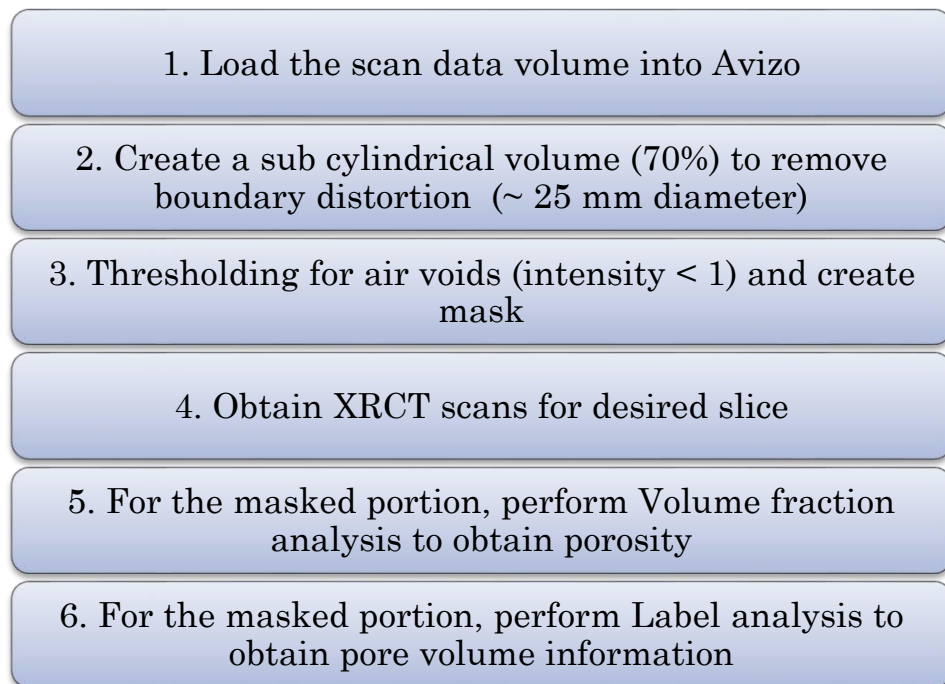

Figure 4.25. Flow chart of different steps involved in image processing and analyses using Avizo

---

### 4.6.2 Test results

#### 4.6.2.1. X-RCT scans

Re-constructed X-RCT scans for unamended, guar gum and xanthan gum stabilised specimens at different curing periods are presented in Figures 4.26 to 4.34 respectively. Among the thousands of slices, only one representative slice for each specimen at a particular curing period is presented here. However, key observations discussed herein are based on examination of slices at various locations of a specimen. In each figure, three re-constructed scans corresponding to soil (a), porosity (b) and combination of soil and porosity (c) are presented. In the X-RCT scan corresponding to the soil, the brightest regions of the scan represent the densest particles of the soil mix such as gravel or sand, while darkest regions represent the least dense particles like air voids. In X-RCT scan corresponding to porosity, the coloured portion represent the voids, while soil particles are in black colour. Lastly, both scans of soil and porosity are overlapped which is presented in part (c) of each figure.

On visual inspection of X-RCT scans for unamended and biopolymer stabilised specimens, it appears that the unamended samples have less void space and are more compact. However, it is important to note here that, the hydrogels are three-dimensional porous networks of bonds connecting soil particles (Brax et al., 2017). As a porous material, it may be expected that the hydrogels have a low attenuation factor which may limit its identification in X-RCT scans and the space occupied by hydrogels to be classified as void. With this limitation, an attempt has been made to analyse the macrostructure of biopolymer stabilised samples. As mentioned, compared to unamended specimens, the void spaces observed in biopolymer stabilised samples appear to be higher. However, it is also possible that the presence of hydrogels has increased the overall void space of biopolymer stabilised samples. Through Scanning Electron Microscopy, it was observed by Chen et al.,(2014) that, apart from connecting the soil particles, hydrogels push aside soil particles which create higher void space. As noted previously, the chemical properties of the biopolymers determine the nature in which the hydrogels interact with soil particles and in turn this may affect the soil structure. Chen et al.,(2014) further notes that, guar gum as a neutral polysaccharide essentially coats the soil particles and form smaller soil aggregations. In case of xanthan gum which is anionic polysaccharide is effective in interacting with clay particles which creates larger soil agglomerations, but induce higher void spaces which is filled with air or biopolymer solution. Though this study was done at high water contents, it is evident that both biopolymers have influence on soil structure. Similar to the observations made by Chen et al.,(2014), visual inspection of X-RCT scans from the present study indicate that the xanthan gum stabilised samples create higher void space than guar gum stabilised samples at macro level. In order to obtain a better perspective on the effect of biopolymers on macrostructure of the soil, quantitative analyses were performed which is discussed in the next section.

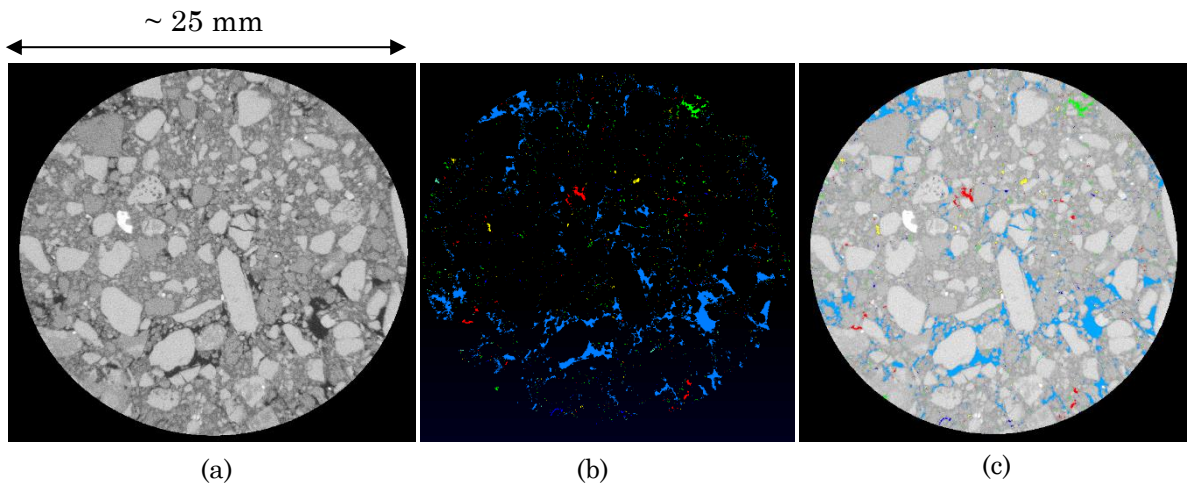

Figure 4.26. X-RCT scans of unamended soil specimens at 1 – day curing period, (a) soil (b) porosity and (c) soil with porosity

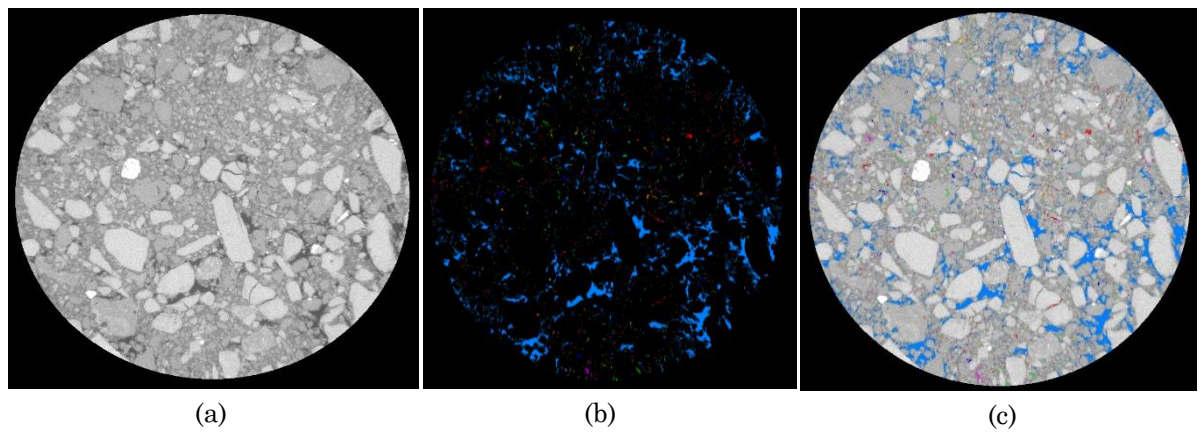

Figure 4.27. X-RCT scans of unamended soil specimens at 7 – day curing period, (a) soil (b) porosity and (c) soil with porosity

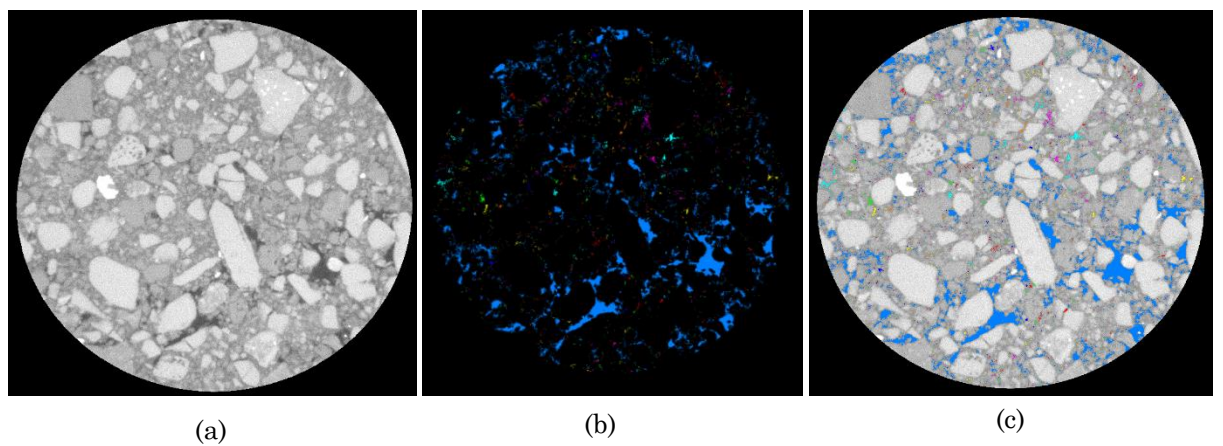

Figure 4.28. X-RCT scans of unamended soil specimens at 28 – day curing period, (a) soil (b) porosity and (c) soil with porosity

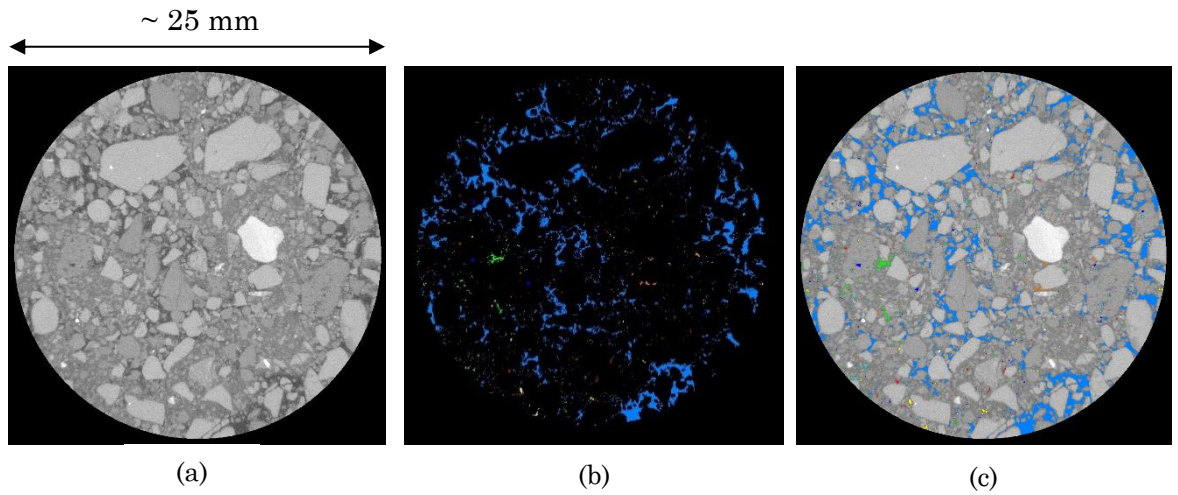

Figure 4.29. X-RCT scans of guar gum stabilised soil specimens at 1 – day curing period, (a) soil (b) porosity and (c) soil with porosity

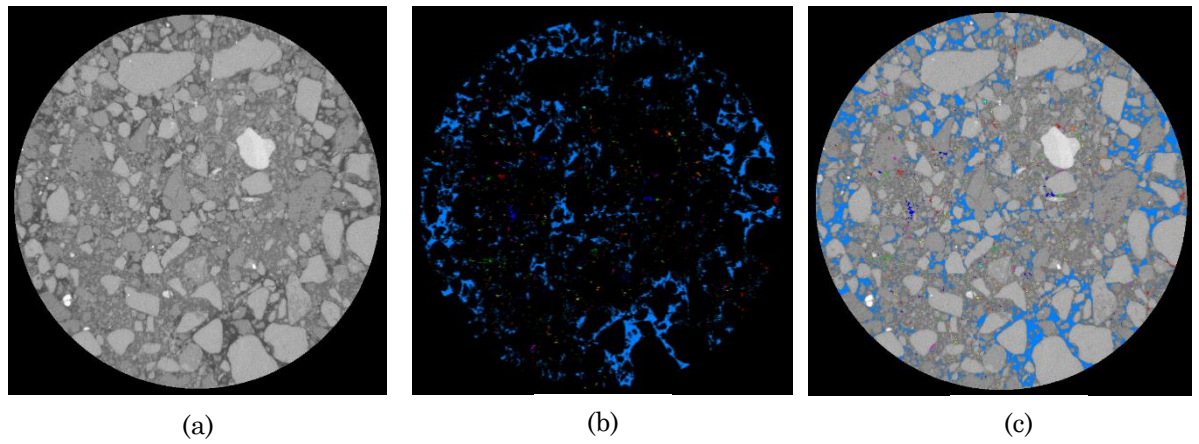

Figure 4.30. X-RCT scans of guar gum stabilised soil specimens at 7 – day curing period, (a) soil (b) porosity and (c) soil with porosity

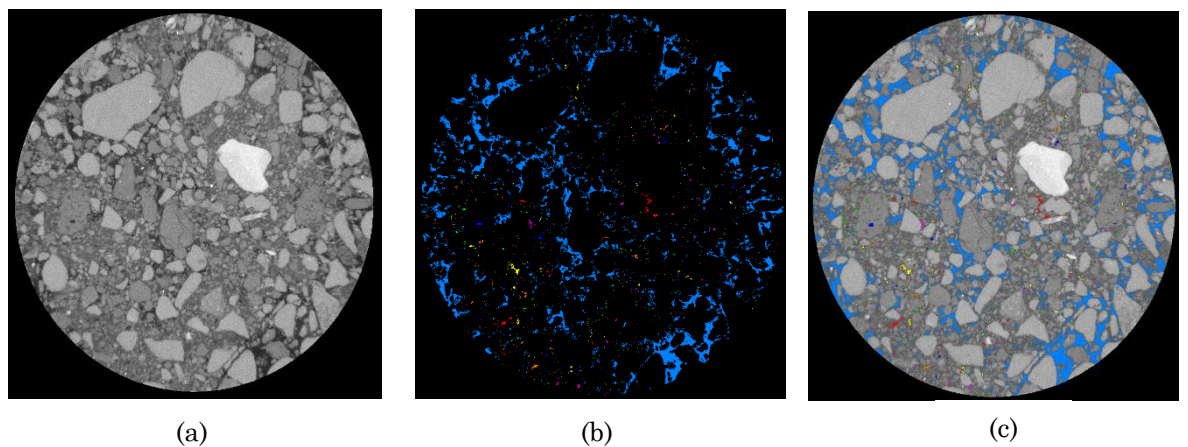

Figure 4.31. X-RCT scans of guar gum stabilised soil specimens at 28 – day curing period, (a) soil (b) porosity and (c) soil with porosity

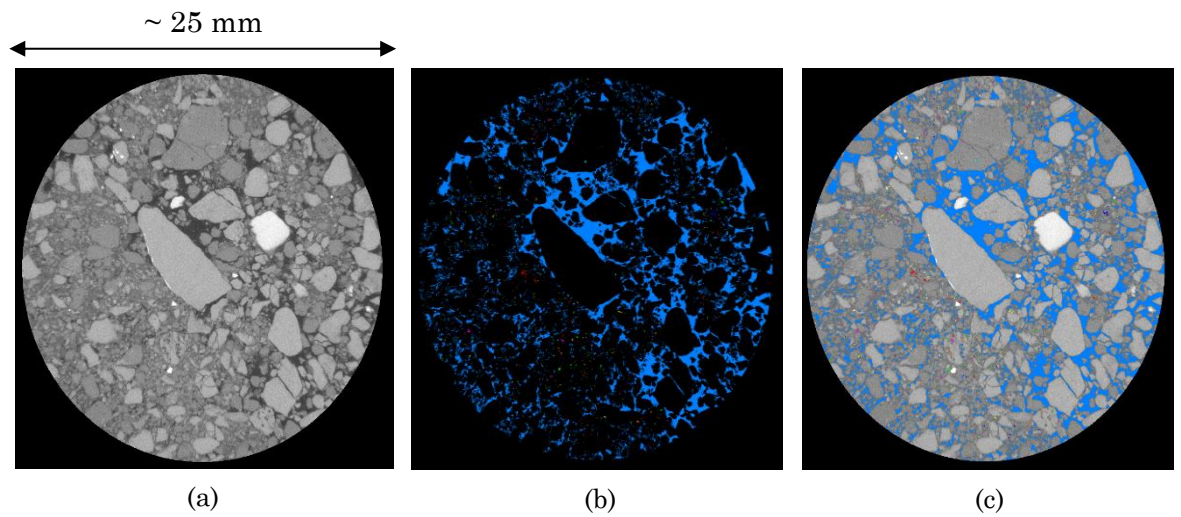

Figure 4.32. X-RCT scans of xanthan gum stabilised soil specimens at 1 – day curing period, (a) soil (b) porosity and (c) soil with porosity

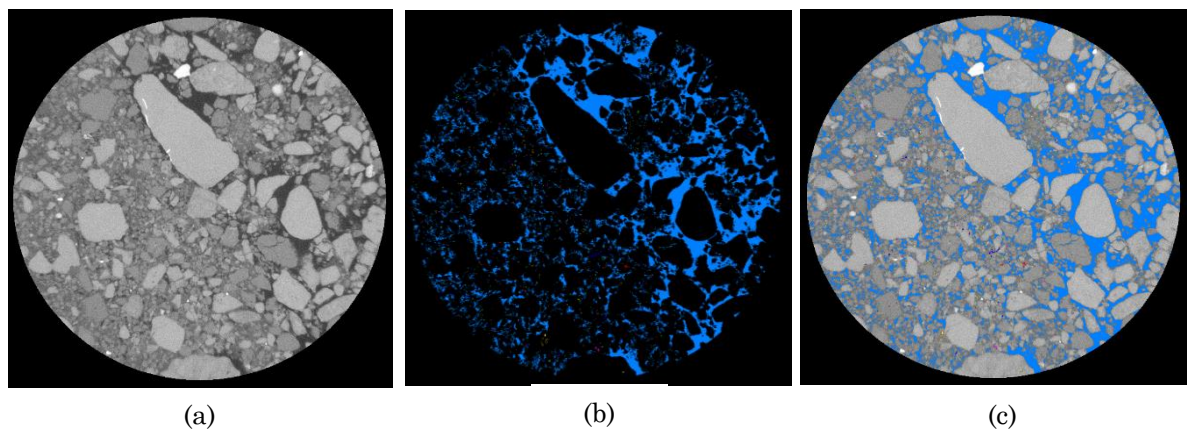

Figure 4.33. X-RCT scans of xanthan gum stabilised soil specimens at 7 – day curing period, (a) soil (b) porosity and (c) soil with porosity

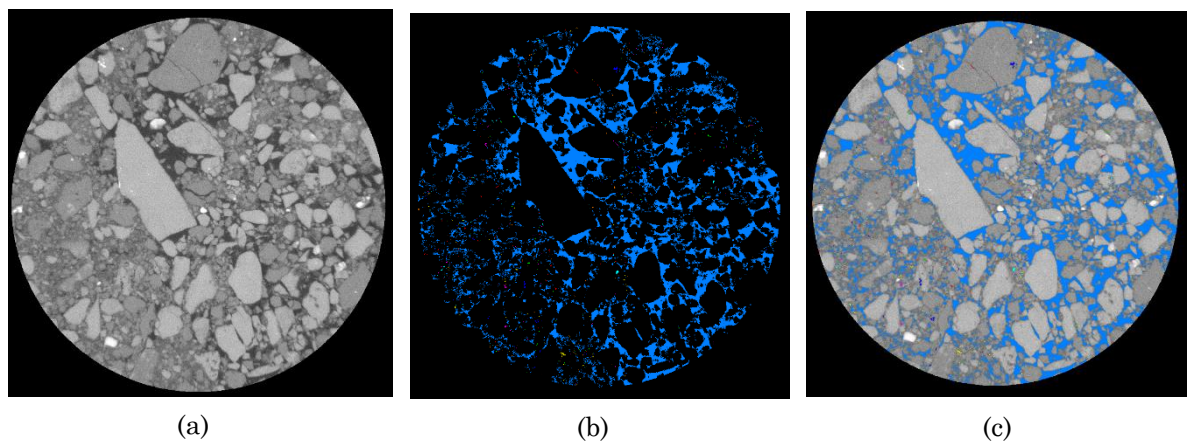

Figure 4.34. X-RCT scans of xanthan gum stabilised soil specimens at 28 – day curing period, (a) soil (b) porosity and (c) soil with porosity

4.6.2.2. Porosity and void size distribution curves

Based on the volume fraction analysis in Avizo, porosity of all specimens at different curing periods were obtained and presented in Table 4.7. It can be observed that the porosity of biopolymer stabilised specimens is comparatively higher than that of unamended samples at all curing periods. Between biopolymers, xanthan gum stabilised specimens have higher porosity than guar gum stabilised specimens at all curing periods. The variations in the measured porosity values of samples complement to the earlier discussion based on the visual inspection of X-RCT scans which indicated that both biopolymers induce void spaces.

Table 4.7. Porosity for all samples at different curing periods.

| Curing Period<br>(days) | Porosity for different samples (%) |      |         |
|-------------------------|------------------------------------|------|---------|
|                         | Unamended                          | Guar | Xanthan |
| 1                       | 6.83                               | 9.03 | 13.68   |
| 7                       | 9.10                               | 9.67 | 15.07   |
| 28                      | 9.68                               | 9.86 | 13.47   |

The results obtained from label analysis from Avizo can be presented in the form of void size distribution curves. In X-RCT obtained void size distribution, cumulative void volume as a percentage of the total sample volume is plotted against void volumes (Smith, 2015). The gradient of the curve at a particular void volume can be used to identify the number of voids of that volume within the sample, i.e. a steep curve suggests there are a high number of voids of that volume, while a flat region within the void size distribution curve suggests there are no voids of the given volume within the sample. Void size distributions of unamended, guar and xanthan gum stabilised soil specimens obtained from label analysis of XRCT scans at different curing periods are presented in Figures 4.35 to 4.37 respectively. As a general observation, it can be noted that all specimens contain voids in a similar range of  $10^3 - 10^8 \mu\text{m}^3$  connected to larger void having a volume in the range of  $10^{10} - 10^{11} \mu\text{m}^3$ . Compared to unamended soil specimen, the size of the large interconnecting void for biopolymer stabilised specimens is larger.

After 1-day curing, the porosity of unamended, guar gum and xanthan gum stabilised specimens were 6.83%, 9.03% and 13.68%. In the initial phase of drying, the soil specimens at 1-day curing period will have higher water content and less air voids than at 7 and 28 days. The soil specimens may have air voids in discontinuous phase where many smaller voids may be present and the size of the interconnecting air void may be small (refer Figures 4.26b, 4.29b and 4.32b). From the void distribution curves (Figure 4.35), it can be observed that, unlike unamended soil specimens, much of the void volume in biopolymer stabilised soil specimens is occupied by the large interconnecting void than the cumulative volume of voids within the range of  $10^3 - 10^8 \mu\text{m}^3$ . For guar gum stabilised sample there are very few voids in the range of  $10^3 -$

$10^8 \mu\text{m}^3$ , this may be due to its high affinity towards water which may ensure that many of the pores are hydrated (Nugent et al., 2009). With better interactions with clay particles and having lesser affinity to water than guar gum, the observed number of voids within the range of  $10^3 - 10^8 \mu\text{m}^3$  of xanthan stabilised specimen is lesser than unamended soil specimens, but higher than guar gum stabilised specimens.

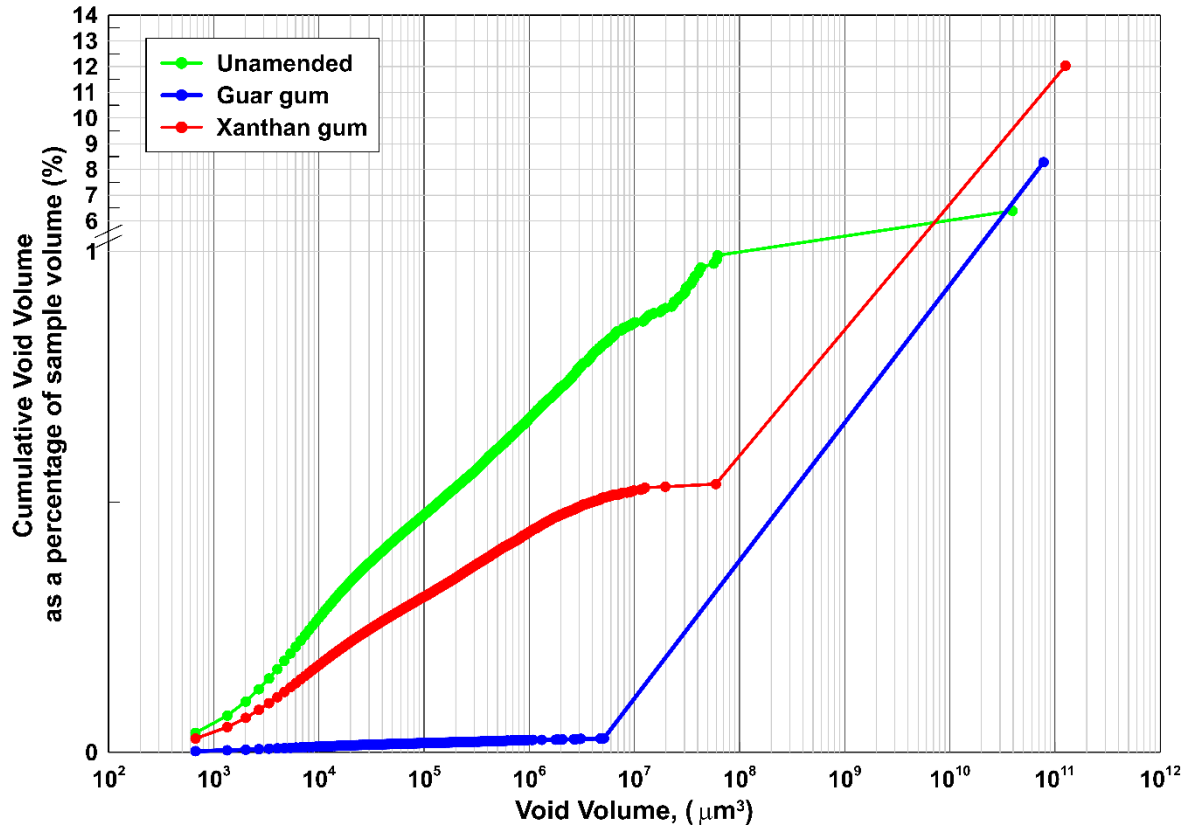

Figure 4.35. Void size distribution of all the specimens after 1 day of curing

After 7 days of curing, the observed porosity values of unamended, guar gum and xanthan gum stabilised specimens were 9.10%, 9.67% and 15.07% respectively. From Figure 4.36, it can be seen that the number of voids for guar gum stabilised specimens has significantly increased compared to 1-day specimen. Further, the number of pores between  $10^7 - 10^8 \mu\text{m}^3$  are higher than unamended and xanthan gum stabilised specimens. As observed from suction versus time plots, the rate of drying for guar gum stabilised specimens is comparatively higher than unamended and xanthan gum stabilised specimens and the largest pores are the one which dry faster than finer pores. These results complement the results of suction versus time plots. Compared to unamended and guar gum stabilised specimens, the number of voids for xanthan gum stabilised specimens in the range of  $10^3 - 10^8 \mu\text{m}^3$  are lower. Further, compared to 1 day, 7 days specimens have fewer number of voids in the range of  $10^3 - 10^7 \mu\text{m}^3$ , while there are no voids in the range of  $10^7 - 10^8 \mu\text{m}^3$ . However, the size of the interconnecting void becomes bigger. This clearly shows that, on addition of xanthan gum, the soil particles form larger stable soil agglomerations which would reduce the number of smaller pores, but as soil agglomerations

they induce higher void spaces which would increase the size of interconnecting void. These results compliment the discussions of triaxial test results and the visual interpretations made earlier.

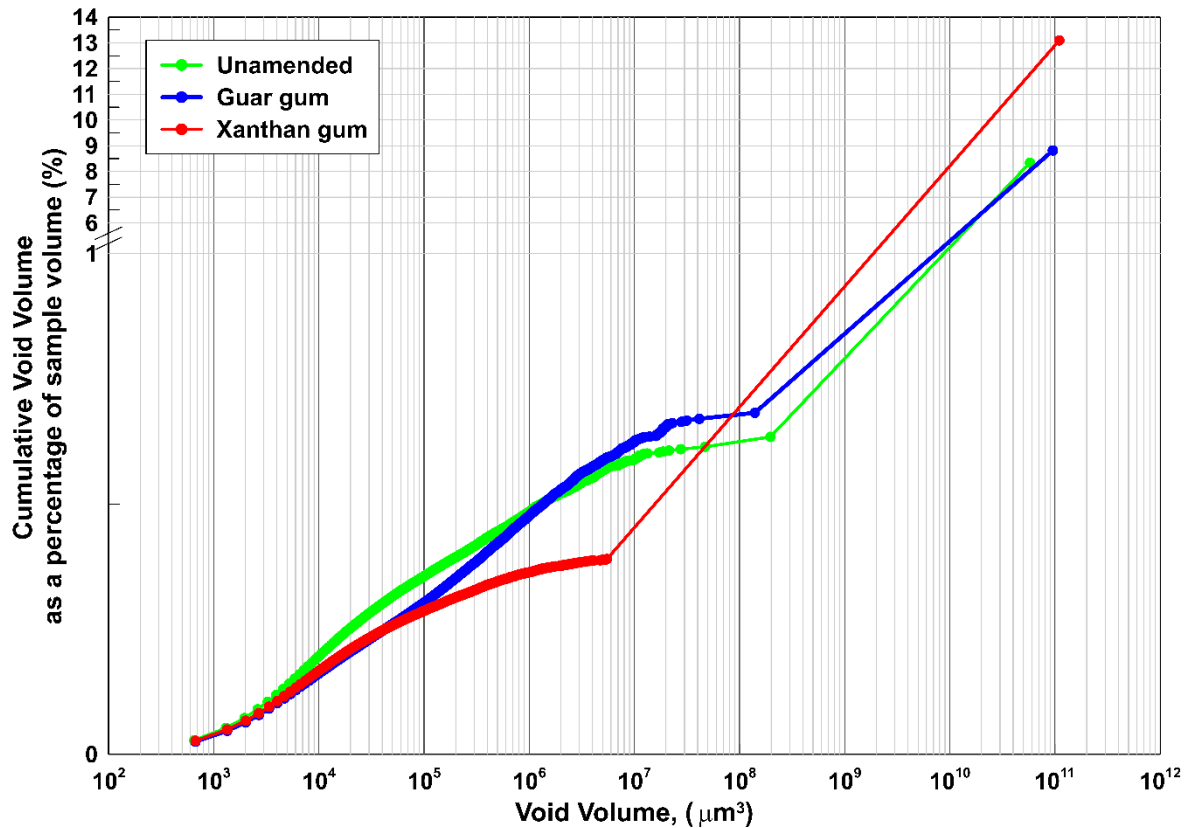

Figure 4.36. Void size distribution of all specimens after 7 days of curing

At 28 days, the porosity values of unamended, guar gum and xanthan gum stabilised specimens were 9.68%, 9.86% and 13.47% respectively. It can be observed from Figure 4.37, that by 28 days, unamended soil specimen has large number of voids in the range of  $10^7 - 10^8 \mu\text{m}^3$ . With aging, it can be expected that the specimen is much drier which would induce larger number of air voids within the specimen. In case of biopolymer stabilised specimens, the number of air voids in the range of  $10^7 - 10^8 \mu\text{m}^3$  remain almost similar indicating that in the residual conditions, much of the water is retained within the soil structure which would not affect its pore structure. These results support the findings of suction tests which suggest more water is retained by biopolymer stabilised soil even after 28 days.

Based on the above discussion, it is evident that both biopolymers have significant and yet different effect on pore structure of the soil mix at macro level. However, due to the limitations of the X-RCT scanning, precise estimate of hydrogel volume in void space could not be estimated. Further, this investigation was limited to understand the effect of biopolymers at macrolevel pore spaces. Considering the intrinsic chemical properties of both biopolymers, it would be certain that they would have significant effect on microstructure of the soil. Any future studies which would quantify the variation in porosities of biopolymer stabilised soils at both

micro and macro level, would certainly help to understand the interactions of biopolymers with soil.

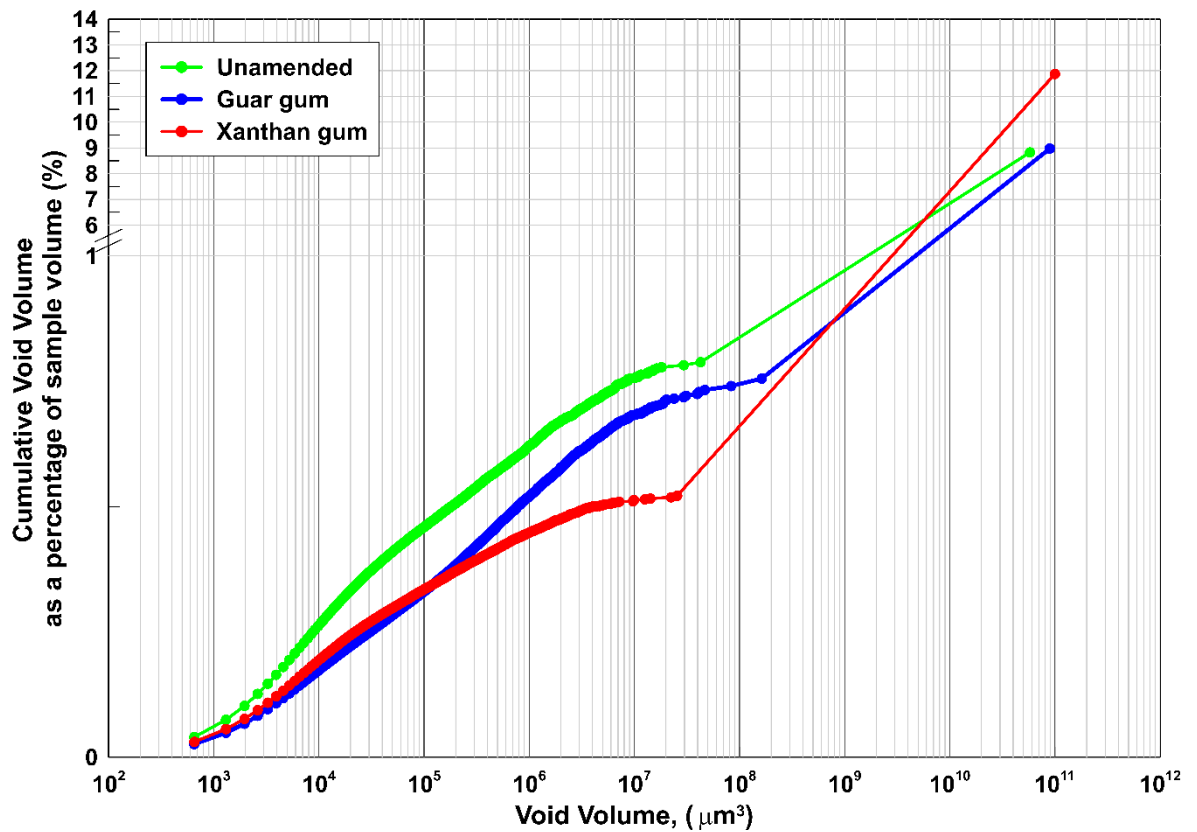

Figure 4.37. Void size distribution of all specimens after 28 days of curing

#### 4.7. Concluding remarks

Based on the geotechnical characterisation, key research conclusions on strength and hydraulic properties of biopolymer stabilised soils and effect of biopolymers on soil macrostructure are summarised below:

1. Suction tests:
  - a. From suction versus time plots, it was observed that the rate of drying of guar gum stabilised specimens is higher than unamended and xanthan gum stabilised specimens. This indicates that, though guar gum has high affinity to water, on drying water tends to escape quickly, as the water molecules are held loosely by the biopolymer chains.
  - b. In case of xanthan gum stabilised specimen, the rate of drying is similar to that of unamended soil specimen, indicating that the hydrogel bonding is not so significant to slow the rate of drying.
  - c. The SWRC of unamended and biopolymer stabilised specimens suggests that for the range of water contents observed, the suction values observed for biopolymer stabilised soils are marginally higher than unamended soil mix.

- d. The effect of biopolymer stabilisation is evident through increased value of fitting parameter,  $a_f$ . With the variation of fitting parameter,  $n_f$  it appears that for the biopolymer stabilised specimens there would be variation in its void size distribution.
  - e. The scanning curves of unamended soil mix in residual conditions matches the description of scanning curves typically observed in unsaturated soils. In case of biopolymer stabilised soils, there is random variation of total suction. It was observed that for a given water content, two or more different suctions were noted. The random variations may be due to the evolution of hydrogels.
2. Constant water triaxial tests:
- a. Stiffness of unamended soil specimens increase as they dry, and once they reach an equilibrium with ambient conditions (within 7 days), the observed stiffness tends to remain similar for subsequent curing periods.
  - b. Peak stresses of the unamended soil increase with higher confining pressures, while stiffness remains unaffected.
  - c. In case of biopolymer stabilised soils, ductile behaviour was observed for 1-day cured specimens. However, this state was short-lived, as the soil specimens dry, the ductile behaviour of specimen transforms to semi-brittle at 4-day curing, while it is brittle after 7 days.
  - d. For unamended soil specimens, after 28 days the cohesion was about 200 kPa and angle of internal friction was about  $31^\circ$ .
  - e. Guar gum stabilised specimens gained strength rapidly within 7 days of curing, however, after 7 days, the change in strength was not so significant. It was also noticed that with aging, the specimens lost cohesion, while the angle of internal friction increased. By the end of 28 days, for the guar gum stabilised specimens the cohesion is about 550 kPa and angle of internal friction is about  $54^\circ$ .
  - f. Similar to guar gum, xanthan gum stabilised specimen gain strength rapidly within 7 days of curing. Unlike guar gum, xanthan gum stabilised soil specimen retains its cohesion, while the angle of internal friction decreases with time. By end of 28 days, for the xanthan gum stabilised specimens the cohesion is about 960 kPa and angle of internal friction is about  $40^\circ$ .
  - g. For the biopolymer stabilised soils, the change in shear strength parameters with aging can be related to the evolution of hydrogels and the intrinsic properties of the biopolymer.
  - h. The shear strength parameters of biopolymer stabilised earthen construction material are higher than the literature reported data and are comparable to the shear strength parameters of cement stabilised rammed earth materials.

### 3. Macrostructure analysis:

- a. As a three-dimensional porous structure, it may be expected that hydrogels have less attenuation factor which may limit its identification in X-RCT scans and the space occupied by hydrogels may be classified as a void.
- b. Visual inspection of X-RCT scans from the present study indicate that the xanthan gum stabilised specimen creates higher void space than unamended and guar gum stabilised specimens at macro level.
- c. The computed macro level porosity of biopolymer stabilised specimens is comparatively higher than that of unamended specimens at all curing periods. Between biopolymers, xanthan gum stabilised specimens have higher porosity than guar gum stabilised specimens at all curing periods.
- d. Void size distribution suggests both biopolymers have significant and yet different effect on pore structure of the soil mix at macro level. The results of void size distribution curves compliment the findings of suction and strength tests.
- e. Due to the limitations of the X-RCT scanning, precise estimate of hydrogel volume in void space may not be determined.

### References

- Araki H, Koseki J, and Sato T. 2011. Mechanical Properties Of Geomaterials Used For Constructing Earthen Walls In Japan. *Bulletin of ERS* (Vol. 44).
- Augarde CE. 2015. Earthen construction: a geotechnical engineering perspective. In *First International Conference on Rammed Earth Construction*. Perth, Australia.
- Ayeldeen MK, Negm AM, and El Sawwaf MA. 2016. Evaluating the physical characteristics of biopolymer/soil mixtures. *Arabian Journal of Geosciences*, 9(5), 329–339.
- Beckett C, Augarde CE, Easton D, and Easton T. 2017. Strength characterisation of soil-based construction materials. *Géotechnique*.
- Beckett C, and Ciancio D. 2015. Tensile strengths of flocculated compacted unsaturated soils, (October).
- Brax M, Buchmann C, and Schaumann GE. 2017. Biohydrogel induced soil-water interactions: how to untangle the gel effect? A review. *Journal of Plant Nutrition and Soil Science*, 180(2), 121–141.
- BS 1377-7. 1990. Methods of test for Soils for civil engineering purposes - Part 7: Shear strength tests (total stress). London: BSI.
- Bui QB, Morel JC, Hans S, and Walker P. 2014. Effect of moisture content on the mechanical characteristics of rammed earth. *Construction and Building Materials*, 54, 163–169.
- Cao J, Jung J, Song X, and Bate B. 2017. On the soil water characteristic curves of poorly graded granular materials in aqueous polymer solutions. *Acta Geotechnica*.
- Chang I, Im J, Prasadhi AK, and Cho G-C. 2015. Effects of Xanthan gum biopolymer on soil strengthening. *Construction and Building Materials*, 74(10), 65–72.
- Cheah JSJ, Walker P, Heath A, and Morgan TKKB. 2012. Evaluating shear test methods for stabilised rammed earth. *Proceedings of the Institution of Civil Engineers - Construction Materials*, 165(6), 325–334.
- Chen C, Wu L, Perdjon M, Huang X, and Peng Y. 2019. The drying effect on xanthan gum biopolymer treated sandy soil shear strength. *Construction and Building Materials*, 197, 271–279.
- Chen R. 2014. Bio Stabilisation for Geopolymer Enhancement and Mine tailings Dust Control. The University of Arizona. Retrieved from <http://hdl.handle.net/10150/319999>
- Chen R, Zhang L, and Budhu M. 2013. Biopolymer Stabilization of Mine Tailings. *Journal of Geotechnical and Geoenvironmental Engineering*, 139(October), 130128212232006.
- Chudzikowski RJ. 1971. Guar gum and its applications. *Journal of the Society of Cosmetic Chemists*, 22(1), 43–60.
- Corbin A, and Augarde C. 2015. Investigation into the shear behaviour of rammed earth using shear box tests. In *Proceedings of the First International Conference on Bio-based Building Materials*. Clermont-Ferrand, France: RILEM. Retrieved from <http://www.rilem.org/gene/main.php?base=500218>
- Decagon Devices. 2015. WP4C WATER POTENTIAL METER. Retrieved June 8, 2017, from <http://www.decagon.com/en/soils/benchtop-instruments/wp4c-water-potential-meter/>
- Eichler S, Ramon O, Ladyzhinski I, Cohen Y, and Mizrahi S. 1997. Collapse processes in shrinkage of hydrophilic gels during dehydration. *Food Research International*, 30(9), 719–726.
- El-Nabouch R, Bui QB, Plé O, and Perrotin P. 2018. Characterizing the shear parameters of rammed earth material by using a full-scale direct shear box. *Construction and Building Materials*, 171, 414–420.
- Fredlund D., Rahardjo H, and Fredlund M. 2006. *Unsaturated Soil Mechanics in Engineering Practice* (Vol. 132). John Wiley & Sons, Inc. Retrieved from <http://ascelibrary.org/doi/10.1061/%28ASCE%291090-0241%282006%29132%3A3%28286%29>
- Fredlund D., and Xing A. 1994. Equations for the soil-water characteristic curve. *Canadian Geotechnical Journal*, 31(4), 521–532.
- Fredlund DG. 1973. Volume change behavior of unsaturated soils. Phd Thesis.
- Fredlund DG, Rahardjo H, Leong EC, and Ng CW. 2001. Suggestions and recommendations for the interpretation of soil-water characteristic curves. In *Southeast Asian Geotechnical Conference* (pp. 503–508). Hong Kong.
- Gallipoli D, Bruno AW, Perlot C, and Salmon N. 2014. Raw earth construction: is there a role for unsaturated soil mechanics. Taylor & Francis Group, London, UK.
- Garcia-Ochoa F, Santos VE, Casas JA, and Gomez E. 2000. Xanthan gum: production, recovery, and properties. *Biotechnology Advances*, 18(7), 549–579.
- Gerard P, Mahdad M, Robert McCormack A, and Francois B. 2015. A unified failure criterion for unstabilized rammed earth materials upon varying relative humidity conditions. *Construction and Building Materials*, 95, 437–447.
- Hillel D. 1980. *Fundamentals of soil physics*. Academic

## Chapter 4. Geotechnical Characterisation

---

- Press, New York. Fundamentals of Soil Physics. Academic Press, New York.
- Jaquin PA, Augarde CE, Gallipoli D, and Toll DG. 2009. The strength of unstabilised rammed earth materials. *Géotechnique*, 59(5), 487–490.
- Jennings JEB, and Burland JB. 1962. Limitations to the Use of Effective Stresses in Partly Saturated Soils. *Géotechnique*, 12(2), 125–144.
- Katzbauer B. 1998. Properties and applications of xanthan gum. *Polymer Degradation and Stability*, 59(1–3), 81–84.
- Ketcham RA, and Carlson WD. 2001. Acquisition, optimization and interpretation of X-ray computed tomographic imagery: applications to the geosciences, 27, 381–400.
- Kocherbitov V, Ulvenlund S, Briggner L-E, Kober M, and Arnebrant T. 2010. Hydration of a natural polyelectrolyte xanthan gum: Comparison with non-ionic carbohydrates. *Carbohydrate Polymers*, 82(2), 284–290.
- Lu N, and Likos WJ. 2004. *Unsaturated Soil Mechanics*. Wiley.
- McQueen IS, and Miller RF. 1974. Approximating soil moisture characteristics from limited data: Empirical evidence and tentative model. *Water Resources Research*, 10(3), 521–527.
- Middleton GF. 1992. *Earth wall construction*. North Ryde, Australia: Commonwealth Scientific and Industrial Research Organisation (Division of Building Construction and Engineering).
- Mudgil D, Barak S, and Khatkar BS. 2011. Guar gum: processing, properties and food applications—A Review. *Journal of Food Science and Technology*, 51(6), 409–418.
- Nugent RA, Zhang G, and Gambrell RP. 2009. Effect of Exopolymers on the Liquid Limit of Clays and Its Engineering Implications. *Transportation Research Record: Journal of the Transportation Research Board*, 2101(1), 34–43.
- Nuth M, and Laloui L. 2008. Advances in modelling hysteretic water retention curve in deformable soils. *Computers and Geotechnics*, 35(6), 835–844.
- Qureshi MU, Chang I, and Al-Sadarani K. 2017. Strength and durability characteristics of biopolymer-treated desert sand. *Geomechanics and Engineering*, 12(5), 785–801.
- Schroeder H. 2016. *Sustainable Building with Earth*. Sustainable Building with Earth. Cham: Springer International Publishing.
- Smith J. 2015. *Examining Soil Based Construction Materials through X-Ray Computed Tomography*. Durham University. <https://doi.org/ear>
- Terzaghi K, Peck BR, and Mesri G. 1963. *Soil Mechanics in Engineering Practice (Third Edit)*. A Wiley-Interscience Publication.
- Torres MD, Moreira R, Chenlo F, and Vázquez MJ. 2012. Water adsorption isotherms of carboxymethyl cellulose, guar, locust bean, tragacanth and xanthan gums. *Carbohydrate Polymers*, 89(2), 592–598.
- Tran TPA, Im J, Cho G-C, and Ilhan Chang. 2017. Soil – water characteristics of xanthan gum biopolymer containing soils. In *Proceedings of the 19th International Conference on Soil Mechanics and Geotechnical Engineering*, Seoul.
- Wijaya M, and Leong EC. 2016. Equation for unimodal and bimodal soil-water characteristic curves. *Soils and Foundations*, 56(2), 291–300.
- Wilson GW, Fredlund DG, and Barbour SL. 1994. Coupled soil-atmosphere modelling for soil evaporation. *Canadian Geotechnical Journal*, 31(2), 151–161.
- Wood DM. 1990. *Soil behaviour and critical state soil mechanics*. Cambridge university press.
- ZEISS. 2014. *ZEISS Xradia 410 Versa Submicron X-ray Imaging: Bridge the Gap in Lab-based Microscopy*. Jena, Germany: Carl Zeiss Microscopy GmbH. Retrieved from <https://www.zeiss.com/microscopy/int/products/x-ray-microscopy/zeiss-xradia-410-versa.html>
- Zhao X. 2014. Measurements and transient multistep outflow simulation of soil-water characteristic curve for soils modified with biopolymers.

# Chapter 5

## Assessment of biopolymer stabilised earthen construction material as a building material

### 5.1 Chapter Introduction

In Chapter 3, a few preliminary durability tests were performed to investigate the potential of both guar and xanthan gum as stabilisers for earthen construction materials. The results indicated that the biopolymer stabilised material had satisfactory durability performance against erosion. In continuation to this durability assessment, further investigations which emulate different in-situ conditions have been carried out to assess performance of both of the biopolymers as stabilisers. The results of these investigations are presented in this Chapter. Further, earthen construction materials are often considered sustainable due to their inherent characteristics of having low embodied energy, low operational energy, they are easily recyclable, provide acoustic insulation and are naturally fire resistant (Calkins, 2008; Ciurileanu and Horvath, 2012; Gallipoli et al., 2014; Schroeder, 2016). In this Chapter, two further aspects are investigated, namely hygroscopic behaviour and recyclability potential of biopolymer stabilised earthen construction materials which can be linked to sustainability characteristics namely low operational energy and recyclability.

### 5.2 Sample preparation

In this section, the manufacturing process of samples used in different investigations is detailed. These investigations were carried out at the geotechnical engineering laboratory of Durham University, United Kingdom and the SIAME laboratory of University of Pau and Pays de l'Adour (UPPA), France.

#### 5.2.1 Materials

In order to maintain material consistency between the two laboratories, it was ensured that the kaolin, gravel and biopolymers used at Durham University were shipped to UPPA. However, due to the large quantities of sand involved, rather than shipping, the sand available in the SIAME laboratory was suitably modified to match the particle size gradation of the sand used at Durham University. To achieve particle size consistency, the unmodified sand was dried at 105°C in an oven for 24 hours. The dried sand was then sieved through series of sieves ranging from 5.0 mm to 0.080 mm. The portions of sand retained on each sieve were collected separately. These portions were then mixed proportionately so as to obtain sand having a similar particle

## Chapter 5. Assessment as building material

size gradation originally used in Durham University. The particle size gradation of the two sands used is presented in Figure 5.1.

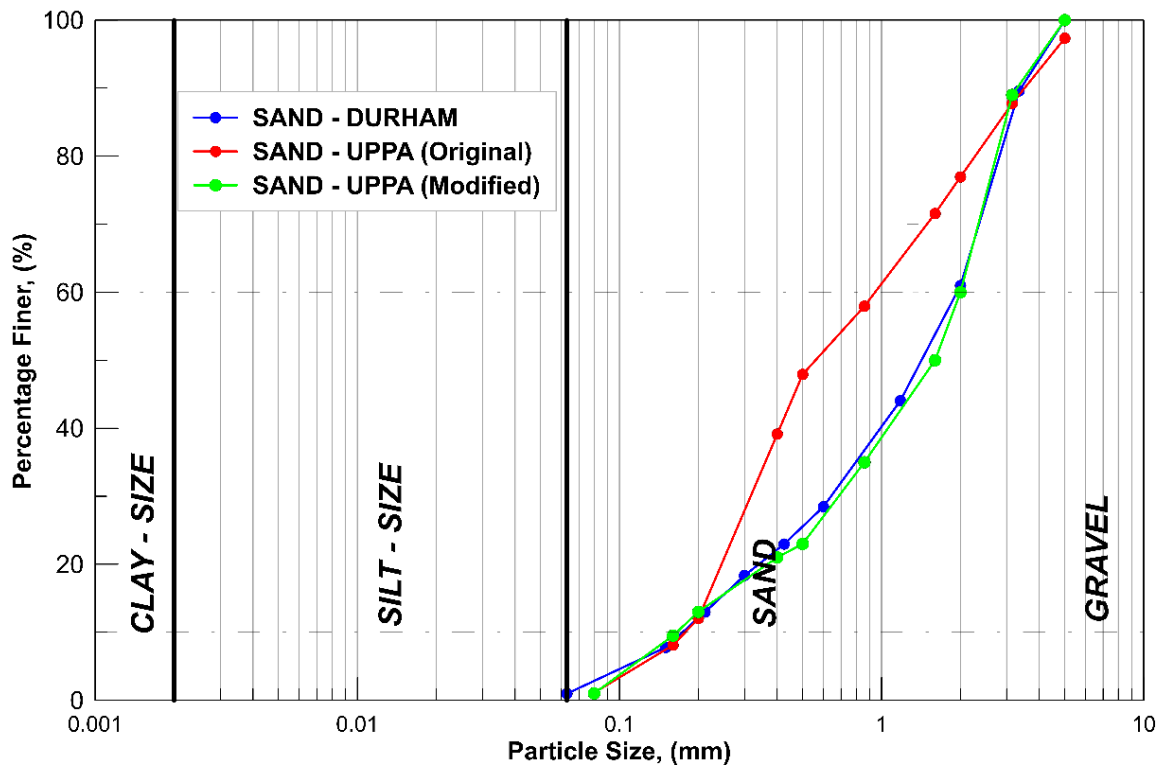

Figure. 5.1. Comparison of particle size gradation of sands used

### 5.2.2 Sample preparation

For the different investigations carried out in this chapter, the size and geometry of the samples used varied. However, in most instances, the manufacturing process of samples with similar size and geometry remained the same. Hence, prior to the discussions regarding different investigations conducted, the manufacturing process is discussed below. Table 5.1 presents the sample size and shape of samples used in the different investigations.

Table 5.1. Different sample configurations considered in this assessment.

| Sample configuration                                  | Durability tests | Hygroscopic tests | Recyclability tests | Laboratory        |
|---|------------------|-------------------|---------------------|-------------------|
| Small cylinder<br>(38 mm diameter and 76mm height)    | √                | -                 | -                   | Durham University |
| Tile<br>(150 mm x 150mm x 20mm)                       | √                | -                 | -                   |                   |
| Larger cylinder<br>(50 mm diameter and 100 mm height) | √                | √                 | √                   | UPPA              |
| Brick<br>(200 mm x 100mm x 50mm)                      | √                | √                 | -                   |                   |

### 5.2.2.1. Small cylindrical specimens

All cylindrical samples of dimension 38 mm and 76 mm height were prepared in the geotechnical engineering laboratory at Durham University and in a similar procedure as described in Section [3.3.2.1](#).

### 5.2.2.2. Tile specimens

Tile specimens of 150 mm x 150 mm x 20 mm were manufactured in the geotechnical engineering laboratory at Durham University. In order to make the tiles, the required quantities (mass basis) of the ingredients (sand, gravel, kaolin and biopolymer) were weighed and initially mixed in the dry condition. For the biopolymer stabilised samples, the chosen biopolymer was pre-mixed with the dry ingredients of the soil mixture. After dry mixing, water equivalent to the optimum water content obtained through the compaction test and the additional water required to make the soil workable was added to the soil mixture and mixed thoroughly as explained in Section [3.3.2.1](#). After mixing, the required bulk mix was weighed and introduced into the 150 mm cube mould and statically compacted to achieve the maximum dry density of the unamended soil mix using a Denison T60C hydraulic press (Figure 5.2). To avoid drainage and ensure safe extrusion of the sample, the cube mould was lined with Teflon paper. In order to achieve the required thickness of 20 mm, the compacting pressure had to be maintained around 2.0 - 2.3 MPa. Once compacted, the cube mould was dismantled and the tile specimen was removed carefully. The tiles were then left to cure in the laboratory atmosphere with relative humidity (RH) of 50% and temperature of 21°C.



(a)



(b)

Figure. 5.2. Preparation of tile specimens, (a) Denison T60C hydraulic press and (b) 150 mm cube mould

---



(a)



(b)

Figure. 5.3. Manufacturing of large cylinders, (a) Zwick Roell press and (b) Mould for cylinders

### 5.2.2.3. Large cylindrical samples

All cylindrical samples of dimension 50 mm diameter and 100 mm height were manufactured in the SIAME laboratory at UPPA. Similar procedures of mixing, compacting and extrusion as involved for the small cylinders were followed to make the larger cylindrical samples. After extrusion, the samples were left to cure at laboratory atmosphere with relative humidity (RH) of 50% and temperature of 23°C. The samples were compacted in a cylindrical mould using a Zwick Roell hydraulic press (Figure 5.3).

### 5.2.2.4. Brick samples

All brick samples of dimension 200 mm width, 100 mm length and 50 mm thickness were manufactured in the SIAME laboratory at UPPA. The chosen dimensions of the brick are similar to those of the standard fired clay bricks commonly used in the United Kingdom (BS 3921, 1985), i.e. 215 mm x 102.5 mm x 65 mm. Unlike cylindrical and tile specimens, the bricks were compacted from both sides simultaneously using an open-ended compaction mould in a 3R RP 3000 TC/TH press (Figure 5.4). The manufacturing process of bricks involved dry mixing of the ingredients required for the soil mix (i.e. sand, kaolin, gravel and biopolymer). The soil mix was later introduced to an electric cement mixer and water equivalent to the optimum water content and the additional water required to make the soil workable was added to the soil mix

progressively. Once the soil mix achieved uniform consistency, the soil mix was used to make bricks.

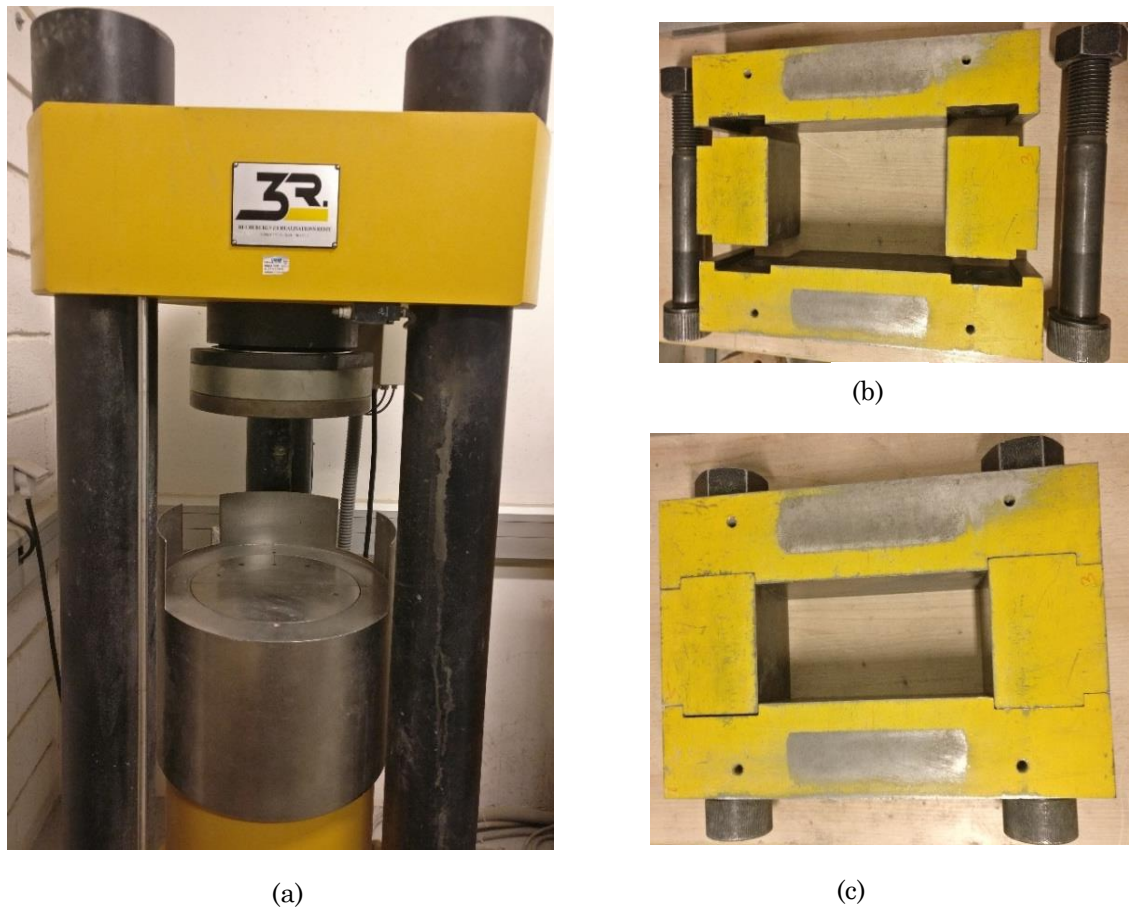

Figure. 5.4. Manufacturing of bricks, (a) 3R RP 3000 TC/TH press, (b) dismantled open compaction mould, and (c) assembled compaction mould

The procedure for assembling the mould, double compaction of the soil mix and extrusion of the brick is detailed below:

- The lower piston is placed on the bottom plate of the press along with the four spacers which are 10 mm shorter than the lower piston (Figure 5.5a). Each spacer is used to support four different parts of the open mould.
- The four parts of the open mould are positioned on top of the spacers so that parts 3 and 4 fit inside the indentations of parts 1 and 2 (Figure 5.5b and 5.5c). These parts are assembled together by tightening the two M42 bolts. In this condition, the lower piston is 10 mm inside the open mould.
- The prepared wet soil mixture is then introduced into the mould and distributed uniformly (Figure 5.5d).

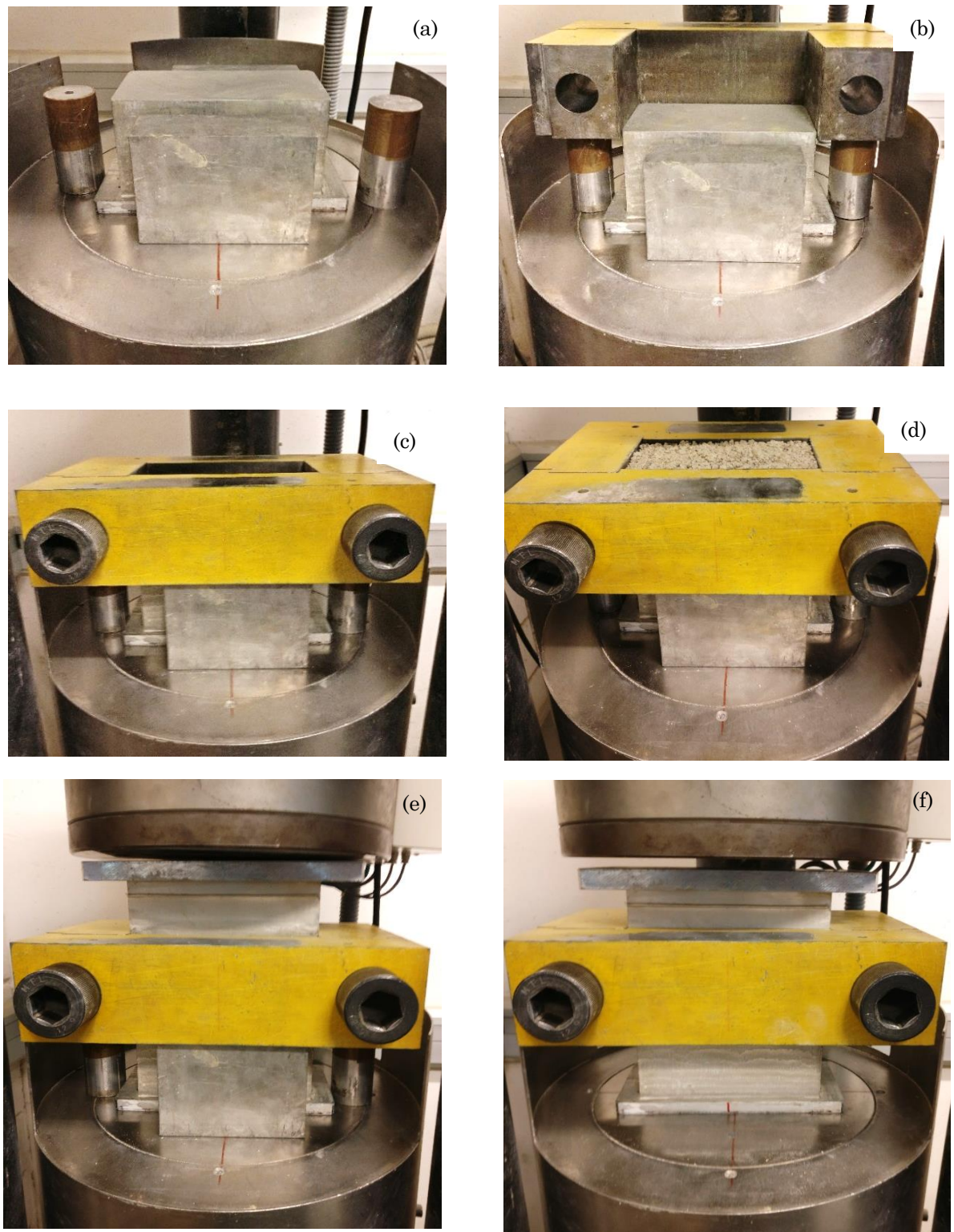

Figure. 5.5. Steps for manufacturing bricks

- The upper piston is then placed on the top of the soil mix and compacting pressure of 0.5-0.75 MPa is applied for few seconds so that the soil sticks to the inner surface of the mould. With this, the mould is held at its place safely even after removing the spacers (Figure 5.5e).

- After removal of the spacers, a compaction pressure is applied, increasing at a constant rate of 0.17 MPa/s until the target penetration is attained and the soil mix is compacted to the required thickness of 50 mm. Being open moulded, both pistons are loaded by the same force and double compaction of the soil is achieved (Figure 5.5f).
- After double compaction, the lower plate of the press is lowered, so as to create enough space between the top plate of the press and the mould such that a spacer can be inserted between them. A load is then gently applied, which pushes the mould down and thus the brick is extruded.
- The extruded brick was then left to cure at laboratory atmosphere with relative humidity (RH) of 50% and temperature of 23°C.

### 5.3 Durability tests

As per BS ISO 15686 (2000), durability is defined as, “*capability of a building or its parts to perform its required function over a specified period of time under the influence of the agents anticipated in service*”. As a walling unit, earthen construction materials like rammed earth and compressed earth blocks need to maintain their structural integrity during their lifetime under different environmental conditions. Unstabilised earthen construction materials remain stable as a unit due to the inter-particle capillary pull exerted by pore water on soil particles. With any introduction of external water, the material loses soil cohesion and becomes susceptible to deterioration (Morel et al., 2012). In a real-life scenario, under the repeated impact of external forces such as rainfall, either entire or portions of the material gets saturated which makes it susceptible to erosion affecting its functionality. Apart from the external environmental forces, the earthen construction material may also absorb water from its immediate surroundings which can lead to surface cracks (Morel et al., 2012). Under these conditions, it is very important to enhance the durability properties of the earthen construction material. To improve durability properties, the soil used in the earthen construction material is usually stabilised with chemical stabilisers like cement (Gallipoli et al., 2017). With chemical stabilisation, the resistance against erosion is enhanced and thus improving the longevity of the material (Bui et al., 2009). As an alternative to cement, it is necessary that the biopolymers need to improve the durability characteristics of the earthen construction material. As seen in Chapter 3, the preliminary durability campaign suggests that both the biopolymers have potential in enhancing the durability properties of the material. As a continuation to this assessment, more durability tests are performed on the biopolymer stabilised earthen construction materials. To assess the durability performance against water induced deterioration, standard durability tests which emulate rain induced erosion, sudden submergence and capillarity rise deterioration are considered. The testing methodology and the results from these tests are discussed in subsequent sections.

### 5.3.1. Rainfall induced erosional tests

To assess durability performance against rainfall induced erosion, different approaches such as, spray tests, wire brush tests, wet to dry strength ratio and drip tests are commonly employed. Several researchers opine that the test conditions of spray tests (NZS 4298, 1998) and wire brush tests (ASTM-D559, 1989; IS 1725, 2013) are more severe than the actual climatic condition observed on site (Heathcote, 1995; Ogunye and Boussabaine, 2002; Walker et al., 2005; Guettala et al., 2006; Morel et al., 2012). Assessment of durability through wet to dry strength ratio approach is considered to be too severe and unrealistic in simulating the actual field conditions (Kerali and Thomas, 2004; Morel et al., 2012). Furthermore, these tests may be considered appropriate only for cement stabilised earthen construction materials. Considering the uncertainties involved in these test methods, drip tests as recommended by NZS 4298 (1998) were chosen in this study to assess durability performance against water erosion. Drip tests emulate the erosional resistance of earthen construction material against impact of rainfall. In the drip tests, within a fixed time span a known quantity of water is made to drip on the surface of the test specimen and the eroded depth on the surface is measured. Based on the eroded depth, the ability of the specimen to resist erosion is assessed. The drip test was originally developed in Deakin University, Geelong to assist adobe owner-builders to determine the suitability of the soil to prepare adobe blocks (Yttrup et al., 1981). Later, Frencham(1982) based on the performance of 20 earthen buildings against rainfall erosion developed a concept of classifying the material based on Erodibility Index which correlates the drip test results with real life performance. Based on the recommendations of Yttrup et al.,(1981) and Frencham(1982), NZS 4298 (1998) describes the procedure of drip tests and associated material categorisation. As an acknowledgement to the original inventors, NZS 4298 (1998) has named the drip test as “Geelong” erosion test. Table 5.2 presents the classification of earthen construction material based on drip test results as per NZS 4298 (1998)

Table 5.2. Classification of earthen construction material as per NZS 4298 (1998)

| Property              | Criteria         | Erodibility Index |
|-----------------------|------------------|-------------------|
| Depth of Erosion (mm) | $5 \leq D < 10$  | 3                 |
|                       | $10 \leq D < 15$ | 4                 |
|                       | $D > 15$         | 5 (fail)          |

#### 5.3.1.1. Testing methodology

The main objective of this investigation was to compare the durability performance against water erosion of biopolymer stabilised earthen construction materials with unamended and cement stabilised materials. For this comparative study, samples in the form of small cylinders

## Chapter 5. Assessment as building material

(36mm diameter and 76 mm length) and thinner tiles (150 mm x 150mm x 20 mm) were considered. As observed from the preliminary durability test results (refer Section 3.3.5) biopolymer stabilised earthen cubes were less susceptible to erosion, hence preparation of thinner tiles was considered to be more appropriate for this comparative study. Since the thickness of the test specimen was reduced, it was possible to carry out a much larger number of test replicates within a shorter duration of time. This increased the confidence in the conclusions drawn from the test results which showed reduced variation.

Cylindrical samples were prepared via a similar procedure as described in Section 3.3.2.1, while tiles were prepared as described in Section 5.2.2.2. All samples were compacted to achieve the maximum dry density of the engineered soil mix, i.e. 19.62 kN/m<sup>3</sup>. The Geelong erosion tests were then performed on samples cured for 7 and 28 days. In total five different biopolymer combinations were chosen for this investigation: two individually stabilised samples and three synergistic combinations (see Section 3.3.3). For the individually stabilised specimens, the biopolymer content was maintained at 2.0%. The performance of these samples was compared with unamended and 8.0% cement stabilised specimens. A total of 35 cylinders and 35 tiles were prepared for this investigation.

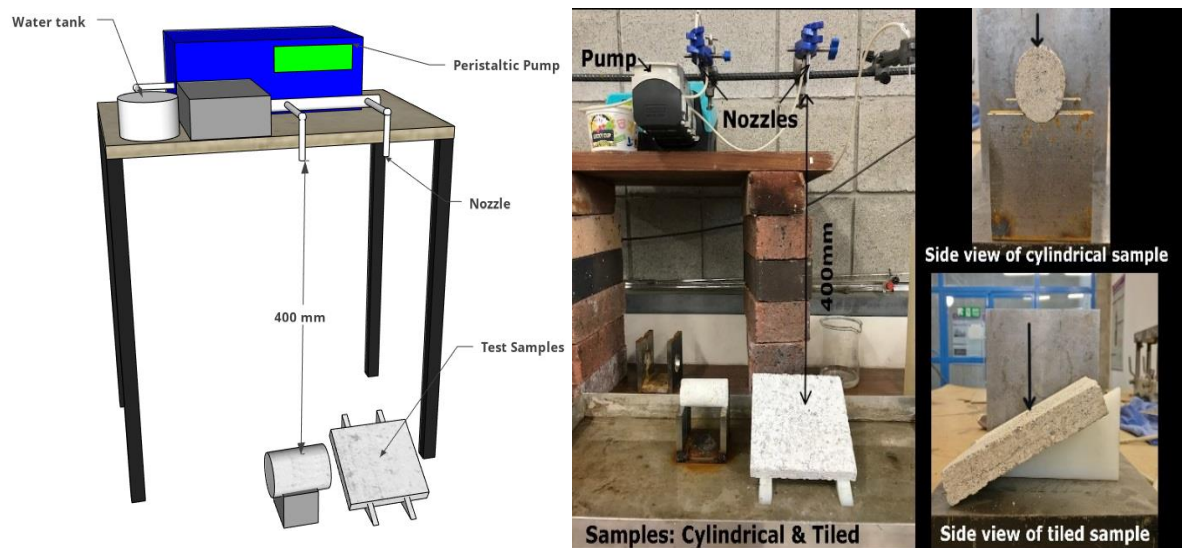

Figure. 5.6. Test setup for Geelong erosion test

The test procedure involves dripping of 100 ml of deionised water within 60 minutes from a height of 400 mm on to the surface of the sample, this simulates the effect of 500 mm of annual rainfall (Heathcote, 1995). Morris (1994) observed that when a saturated wick was used to generate water drops, the drip rate was not controllable. Similar observation was noted when dripping of water was done through burette during the preliminary durability tests. In order to avoid this discrepancy and maintain a steady dripping rate of water, a peristaltic pump was used. For the tile samples, the surface was kept at an inclination of 2H:1V, while for cylindrical specimens the surface of erosion was held perpendicular (Figure. 5.6). As well as noting the final

## Chapter 5. Assessment as building material

erosion at 60 minutes as recommended by the standard, the eroded depths were also noted at intermediate 15 minutes intervals. The results presented herein are the average values of five replicates (Figure 5.7).

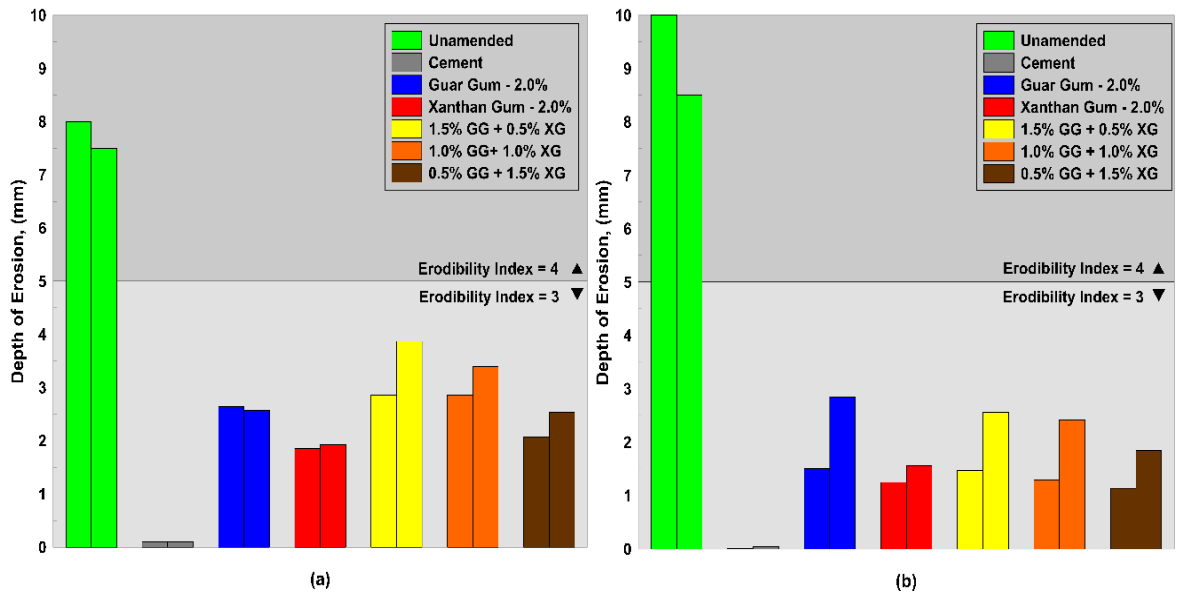

Figure 5.7. Average depth of erosion for (a) tile specimens and (b) cylindrical specimens

### 5.3.1.2. Results and discussion

Figures 5.6a and 5.6b presents the final eroded depth after 60 minutes for both tile and cylindrical samples for all the combinations considered. In each plot, for each combination, the erosional depths measured at 7 and 28 days are plotted adjacent to each other. It can be observed from the results that the unamended samples have higher depths of erosion for both tile and cylindrical samples, while cement stabilised samples have negligible erosion. Based on the recommendations of NZDS 4298 (1998), the erodibility indices for unamended and cement stabilised specimens are 4 and 3 respectively, indicating that unamended specimens are more prone to more erosion. For all combinations of biopolymer stabilised specimens, the final erosional depths are well within 5 mm. Amongst biopolymer combinations, specimens with higher combinations of xanthan gum have performed better. In addition, excluding unamended specimens, all other tiled specimens have higher erosion depth than the cylindrical specimens. The variation in erosion depth may be related to the angle of incidence at which the impact of water occurs. Eassey(1997) suggested that the rate of erosion of the earthen construction material is dependant on the angle of incidence and concluded that the highest rate of erosion occurs when the impact is at an angle of  $30^{\circ}$  to the specimen surface, while least erosion occurs when the impact is at an angle of  $90^{\circ}$ . For tile specimens, the angle of incidence was maintained at  $27^{\circ}$  which is very near to  $30^{\circ}$  where highest impact of erosion occurs. In the case of cylindrical specimens, the impact occurred normal to the surface of the specimen, hence the observed depth of erosion for cylindrical specimens are lesser than tile specimens.

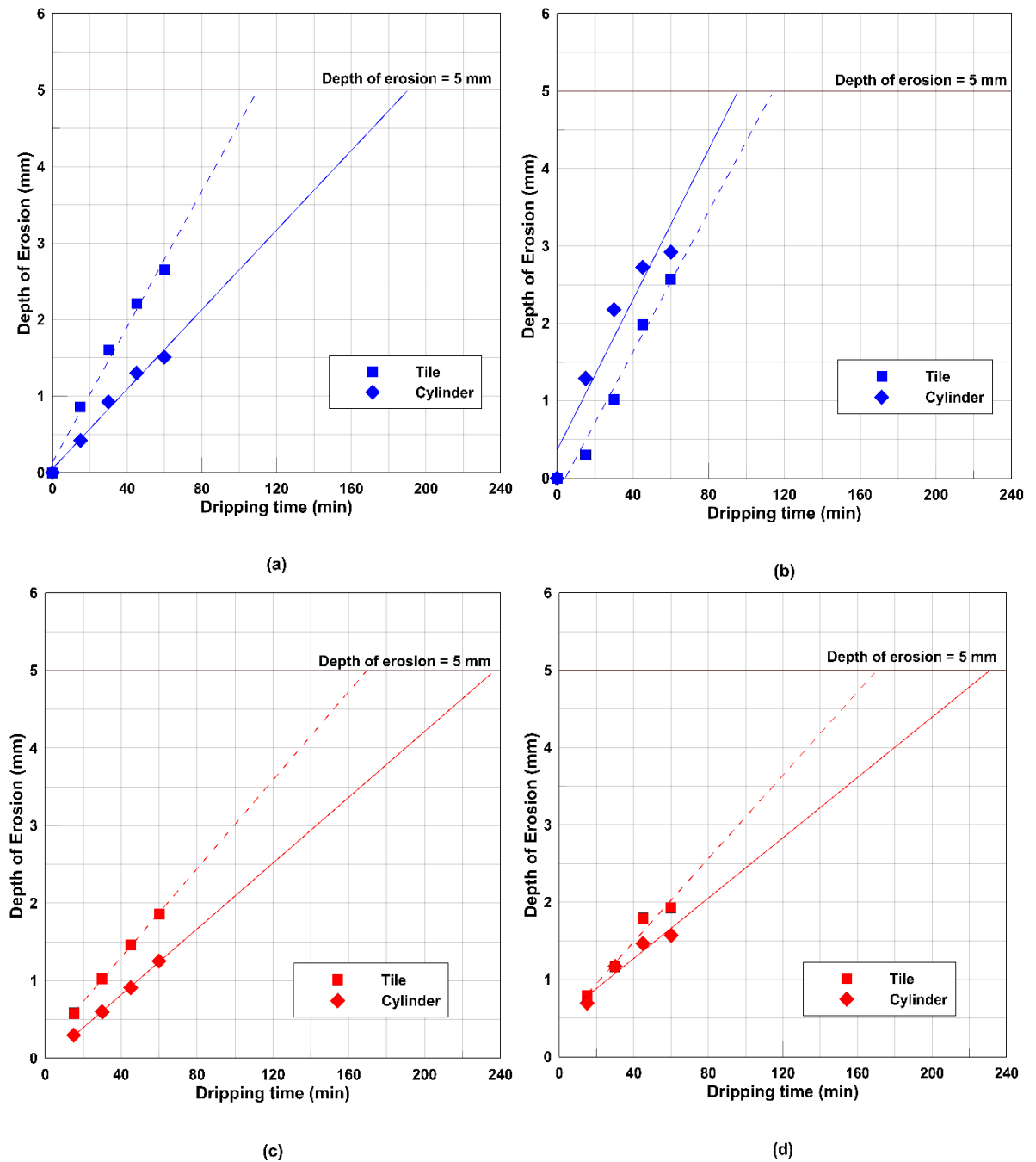

Figure. 5.8. Rate of erosion for (a) guar gum, 7 days, (b) guar gum, 28 days, (c) xanthan gum, 7 days, (d) xanthan gum, 28 days

To compare the individual performances of the biopolymers, the rate of erosion determined during the drip tests was plotted (Figure 5.7). It can be observed from Figure 5.8, the rate of erosion for xanthan gum stabilised specimens was less than that of guar gum stabilised specimens. Further, a linear extrapolation was carried out in order to arrive at the time required to achieve an erosion depth of 5 mm. Practically, a linear relationship of erosion with time is an highly unlikely situation, as the factors which influence erosion such as rainfall intensity, angle of impact and duration of rainfall are highly variable. However, past studies have incorporated

## Chapter 5. Assessment as building material

---

linear extrapolation of erosion to obtain fair indication on the erosional resistance of the material (Bui et al., 2009). It can be observed from Figure 5.7, in comparison to 7 day specimens, the rates of erosion for guar gum stabilised specimens at 28 days are higher, indicating with aging, the specimens tend to erode faster. As noted in Chapter 3, guar gum stabilised samples tend to lose tensile strength when the nature of hydrogels change to “glassy” state. In this state, the network of hydrogels which connects soil particles with weaker hydrogen bonds can be easily broken under low tensile stresses. On repeated impact of water in erosion tests, it can therefore be expected of 28-day specimens with lower tensile strength to have higher erosion rates than 7-day specimens. In the case of xanthan gum, the additional ionic bonds which provide higher tensile strength after 28 days (Figure 3.14b), may provide necessary resistance against erosion even when the hydrogels are in glassy state. This could explain why the observed rates of erosion are similar for 7-day and 28-day xanthan gum stabilised specimens. The test results clearly indicate that the addition of biopolymers certainly improves the erosional resistance of earthen construction materials, and since it possesses better stabilisation mechanisms, xanthan gum has better performance. Any future studies to understand the durability performance of biopolymer stabilised earthen construction materials in an in-situ condition would improve the confidence on these novel stabilisers.

### 5.3.2. Contact tests

The prime objective of a contact test in this context is to assess the response of a brick to moisture absorption in a condition which stimulates the application of a mortar joint, so this test would be only appropriate when the earthen construction material is used as compressed earth blocks. Contact tests were performed for unamended, guar gum and xanthan gum stabilised bricks. Bricks were prepared in accordance with the procedure described in Section 5.2.2.4 and the stabiliser content for biopolymer stabilised bricks was kept constant at 2.0 % of the dry soil mass. The contact tests were performed after 28 days of brick preparation. Prior to the start of the test, the brick specimens were left to equalise in a climatic chamber under 50% RH and 23°C for 48 hours.



Figure. 5.9. Test Setup for Contact test

### 5.3.2.1. Test procedure

The test procedure used in this study is in accordance to DIN 18945 (2013). It consists of applying a wet cellulose cloth on the intermediate face of the brick, which simulates the mortar joint or coating (Figure 5.9). The amount of water in the wet cloth is set equivalent to  $0.5 \text{ g/cm}^2$  which is an average amount of water contained in a 15 mm thick mortar layer (Schroeder, 2016). The brick along with the wet cloth is then placed in a container and is supported by a metallic block. It is ensured that the container is filled with some water at the bottom to ensure humid environment. The container is then sealed for 24 hours. After 24 hours, the brick is removed from the container and exposed to atmospheric conditions for 48 hours. The brick is then visually examined for any cracks or swelling which would lead to permanent deformations due to water absorption.

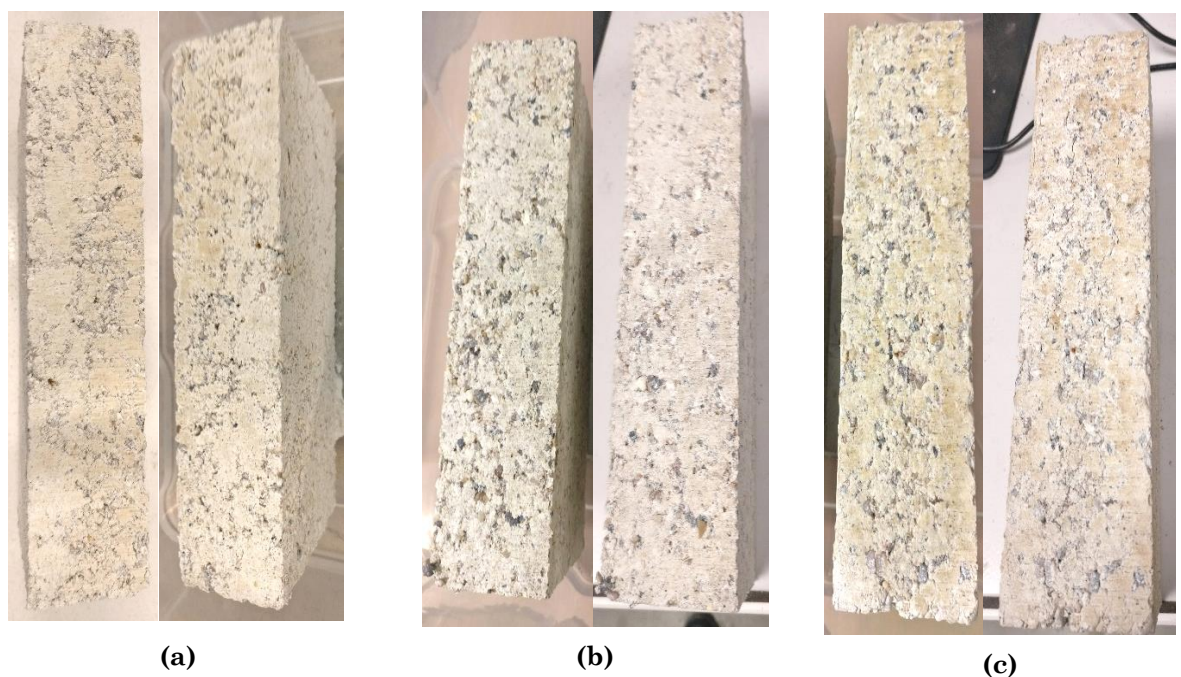

Figure. 5.10. Conditions of bricks before and after contact tests for, (a) unamended bricks, (b) guar gum stabilised bricks, and (c) xanthan gum stabilised bricks

### 5.3.2.2. Test results

Figure 5.10 shows the condition of bricks before and after the completion of contact tests for unamended, guar gum and xanthan gum stabilised bricks. It can be observed that all bricks showed no signs of visible cracks after completion of the tests. As noted in Chapter 3, the soil mix, which has kaolinite as the principal clay mineral, has a linear shrinkage value of 5.0 %, indicating the soil is less prone to cracking (NZS 4298, 1998). With this property, the unstabilised brick may be less susceptible to cracks under these experimental conditions. It is interesting to note, biopolymer stabilised soil mixes which exhibited higher linear shrinkage values showed no visible cracks (see Section [3.3.1.2](#)). As the tests were conducted after 28 days

## Chapter 5. Assessment as building material

of curing, it may be expected that the hydrogels formed due to biopolymer stabilisation were in a glassy state and therefore might resist shrinkage thus inhibiting crack formation on the brick surfaces.

### 5.3.3. Suction tests

Suction tests investigate the durability of earthen blocks when exposed to an excess supply of water. Suction tests emulate the capillarity water rise from the foundation to the walls of the earthen building (Bruno, 2016). Similar to the contact test, suction tests were performed for unamended, guar gum and xanthan gum stabilised bricks. The bricks used in suction tests were prepared as per the procedure described in Section 5.2.2.4. Once again, the stabiliser content for biopolymer stabilised bricks was kept constant at 2.0 % of the dry soil mass. Suction tests were performed after 28 days of brick preparation. Test bricks were conditioned under standard atmospheric condition ( $23 \pm 2^{\circ}\text{C}$ ,  $50 \pm 5\%$  RH) for about 48 hours.

#### 5.3.3.1. Test procedure

The test procedure followed is in accordance with DIN 18945 (2013). A support made of a conventional fired brick with an absorbent cloth on top is placed inside a container. The container is then filled with water up to 1-5 mm below the upper edge of the fired brick (Figure 5.11). After this, the test brick is placed over the absorbent cloth, which marks the start of the suction test. Water is maintained at this level, as it is absorbed by the earthen bricks. Samples are then visually assessed at intervals of 30 minutes, 3 hours and 24 hours from the beginning of the test in order to detect cracks and permanent deformations owing to swelling.

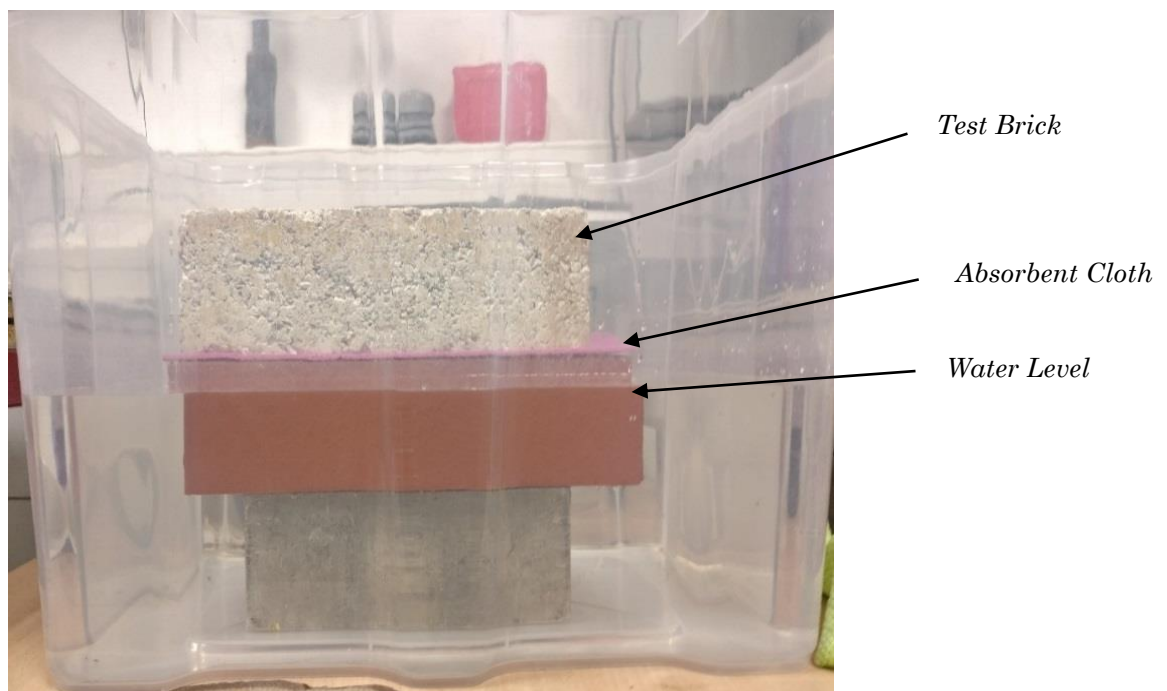

Figure. 5.11. Test setup for the suction test

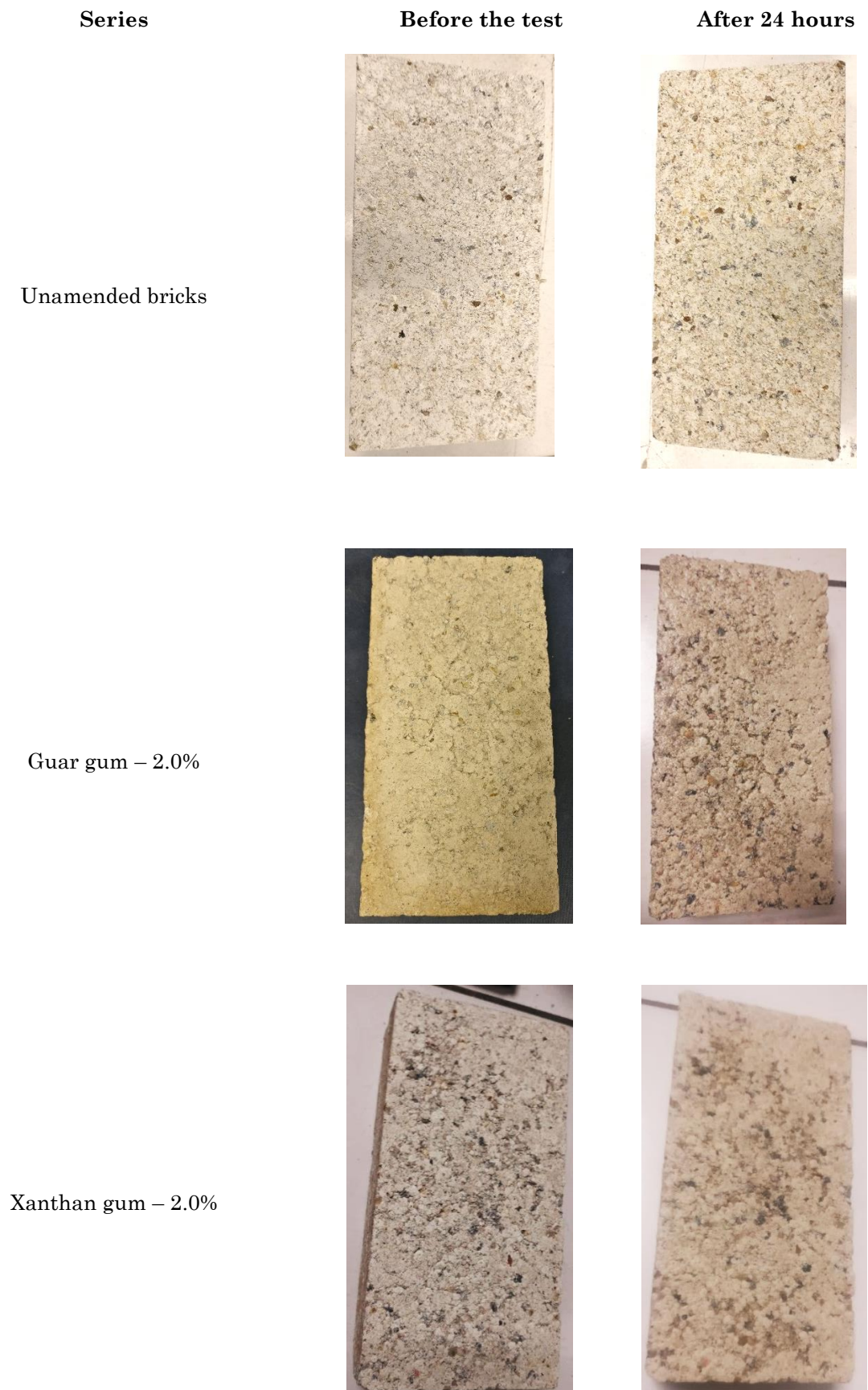

Figure. 5.12. Condition of bricks before and after the suction tests

### 5.3.3.2. Test results

Figure 5.12 shows the condition of bricks before and after the completion of suction tests for unamended, guar gum and xanthan gum stabilised bricks. Similar to contact tests, all bricks showed no signs of cracking or swelling, however it was observed that the surface of the brick (about 2-3 mm) was softened at the end of the test. As discussed previously, the unamended soil mix has a linear shrinkage value of 5.0%. This indicates that the soil mix has better volumetric stability and less susceptible to cracking or swelling. With these characteristics, it can be expected that the unamended bricks to resist deterioration in suction tests. In case of biopolymer stabilised bricks, after 28 days of preparation, it can be expected that the hydrogel formations to be predominantly in glassy state which would resist deterioration within the time frame of the test.

### 5.3.4. Dip tests

The dip test, as described in DIN 18945 (2013) assesses resistance of earthen materials to deterioration during suspension in water rather than absorption (Schroeder, 2016). This test emulates sudden flooding or immersion of earthen material in water, e.g. the effect on a wall in a flooding incident, and is clearly a seriously difficult test for an uncemented material. Dip tests were performed on unamended, guar gum and xanthan gum stabilised bricks.

#### 5.3.4.1. Test procedure

Figure 5.13 shows the test setup for dip tests. Before the start of the test, the mass of the test bricks are recorded. Using a mounting device, the brick is lowered 10 cm into water for 10 minutes. After this specified time, the brick is removed from the water bath and allowed to dry at 40°C, and is then placed under atmospheric conditions to cool before its final mass is measured. The loss of mass is then calculated through the differences of initial and final masses weighed.

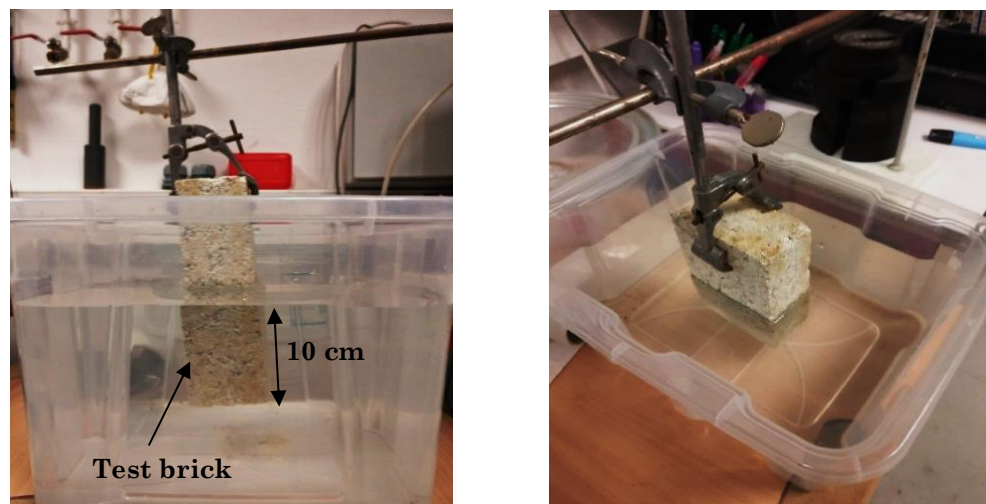

Figure. 5.13. Test setup for dip tests

### 5.3.4.2. Test results

Figure 5.14 shows the mass loss for all the bricks tested. It can be observed that the loss of mass of unamended bricks are significantly higher than for biopolymer stabilised bricks; the loss of mass of unamended bricks is greater than 15%. However, in the cases of both guar and xanthan gum stabilised bricks the observed loss of mass was less than 5%. Furthermore, it was noticed that for guar stabilised bricks, after drying the sample at 40°C, the immersed portion of brick was slightly moist as compared to the unimmersed portion of the brick. Figure 5.15 shows the conditions of bricks immediately after removing from water for all bricks.

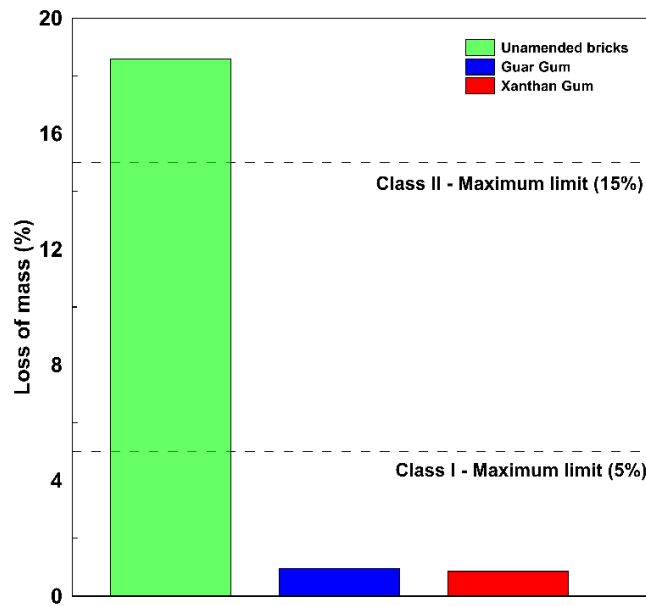

Figure. 5.14. Loss of mass for all the bricks after dip tests

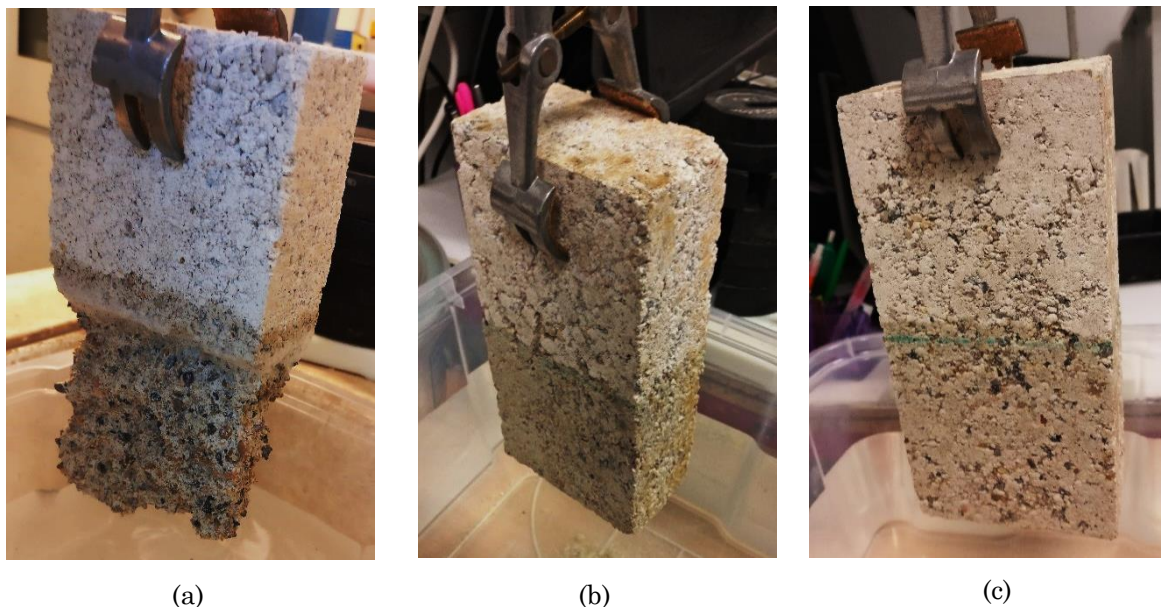

Figure. 5.15. Conditions of bricks after dip tests: (a) unamended brick, (b) guar gum stabilised brick and (c) xanthan gum stabilised brick

### 5.3.5. Discussion on durability tests

The primary objective of contact and suction tests is to assess the resistance of earthen construction material against moisture ingress caused by capillary phenomenon of water. Under the given test conditions, when the test specimen comes in contact with the wet absorbent cloth, water enters the specimen and is held within the pores of the soil through capillary and adsorptive action. Later, on drying, the water evaporates leaving the pore spaces filled with air. Under this cycle of wetting and drying, the ability of the clay mineral to swell due to absorption of water determines the overall extent of swelling of the earthen material and in turn, the formation of cracks. The unamended soil mixture used consists of refined kaolin which has kaolinite as the principal clay mineral, which amongst all the clay minerals has least affinity towards water and it is less susceptible to volume changes (Terzaghi et al., 1963). As supported by the linear shrinkage values presented in Chapter 3, it can be expected that the unamended bricks would therefore anyway be less prone to crack formation due to capillary action and this is confirmed here by the test results of contact and suction tests. In the case of biopolymer stabilised earthen bricks, though the observed linear shrinkage values were higher than an unamended soil mix (as seen in Chapter 3), the effect of capillary action of water on volume changes of the test specimens seem to be less pronounced than unamended bricks. This may be linked to the age of the bricks on which these tests were conducted. Both the contact and suction tests were performed on bricks left to cure for 28 days. At this stage, it can be expected the hydrogels formed within the bricks due to the presence of biopolymers will primarily be in a glassy state and thus provide necessary resistance against moisture ingress caused due to capillary action.

Test results obtained from dip tests clearly show the inability of unamended bricks to withstand immersion. During the dip test, as the mounted brick is half immersed, the immersed portion saturates rapidly which significantly reduces the soil suction which binds the soil particles when in an unsaturated condition. In addition, under the action of gravity, the immersed portion of the brick tends to settle down in water, while the other end of the brick is fixed, this tends to create tensile stresses within the immersed portion of the brick. As observed in Chapter 3, the tensile strength of the unamended engineered soil mix in unsaturated condition was lesser than cement and biopolymered stabilised soil mix. It can therefore be expected during immersion when the soil suction is less, the mobilised tensile strength will be negligible. In this condition, the unamended brick can be expected to deteriorate rapidly. In the case of biopolymer stabilised samples, when subjected to immersion, the hydrophilic hydroxyl groups at the outer chains of the biopolymer absorb and hold water (Gulrez et al., 2011). Further as water is absorbed within the chains of biopolymer and fills up the voids, the hydrogels within the soil matrix tend to swell slightly before starting dilution. The amount of water absorbed and held within the chains of biopolymer and the time taken for dilution depends on the intrinsic chemical properties of the biopolymer (Gulrez et al., 2011). It can be observed from the test

## Chapter 5. Assessment as building material

results, there is negligible loss of mass for both guar and xanthan gum stabilised bricks, while for the guar gum stabilised bricks, even after drying the sample at 40°C, the immersed portion of the brick was slightly moist. From this observation, it may be concluded that within the time period of the test, the biopolymer chains may have only absorbed water and hydrogels may not have reached the stage of dilution to cause any deterioration. Furthermore guar gum's higher affinity towards water may hold more water between polymer chains and soil pores on immersion (Nugent et al., 2009).

Compressed earth blocks can be classified into different categories based on their performances against different durability tests as per the recommendation given by DIN 18945 (2013) (Table 5.3). Based on these recommendations, the tested specimens in this study are classified in Table 5.4. It can be noted that, apart from dip tests, unamended bricks fare well in contact and suction tests, however, with the addition of biopolymers, earthen bricks have acceptable performance also in dip tests which enhances their classification to Ia. With this improvement, biopolymer stabilised earthen blocks could potentially be competitive for external walls exposed to natural weathering.

Table 5.3. Classification of compressed earth blocks as per DIN 18945 (2013).

| Class | Application                                 | Contact tests                                   | Suction tests (h) | Dip tests Mass loss (%) |
|-------|---|---|-------------------|-------------------------|
| Ia    | External wall exposed to natural weathering | No cracks and no permanent swelling deformation | ≥ 24 h            | 5%                      |
| Ib    | Coated external wall                        |   | ≥ 3 h             | 5%                      |
| II    | Internal wall                               |   | ≥ 0.5 h           | 15%                     |
| III   | Dry applications                            | No requirement                                  | No requirement    | No requirement          |

Table 5.4. Classification of earthen construction materials as per DIN 18945 (2013).

| Series      | Contact tests | Suction tests | Dip tests |
|-------------|---------------|---------------|-----------|
| Unamended   | Ia            | Ia            | III       |
| Guar gum    | Ia            | Ia            | Ia        |
| Xanthan gum | Ia            | Ia            | Ia        |

The beneficial effect of biopolymer stabilisation is also more evident in another adverse durability test, i.e. the “Geelong” erosion test. The depths of erosion as observed in these tests were as low as 2.0 mm for biopolymer stabilised earthen materials, while for unamended samples it was in the range of 8.0 - 10.0 mm. Based on the recommendations given by Frencham(1982), biopolymer stabilised earthen material having depth of erosion less than 5.0 mm can be classified as “slightly erodible”. In terms of NZS 4298 (1998), biopolymer stabilised bricks which have depth of erosion less than 5.0 mm should then be subjected to a more precise

durability assessment undertaken by more adverse durability test such as spray test. From these observations, it can be concluded that the addition of biopolymers has certainly improved the erosional resistance of earthen material and this also arises a scope for future studies to assess their durability performances through more vigorous durability tests such as spray tests.

### 5.4 Hygroscopic behaviour of earthen construction materials.

The hygroscopicity of the earthen construction materials is the ability of the material to achieve equilibrium with vapour pressure in its environment. This property of the material determines the indoor air quality and humidity within the building in which they are employed. Padfield (1998) and Padfield and Jensen(2011) have previously recognized that unstabilised earthen construction materials have better hygroscopic characteristics which can self-regulate indoor humidity and hence add to these material's utility and green credentials. However, as noted by McGregor et al.,(2014) and Arrigoni et al.,(2017), addition of chemical stabilisers like cement reduces the hygroscopic property of the stabilised earthen construction materials. On the other hand, as noted from the suction tests (in Chapter 3 and Chapter 4), under similar environmental conditions, biopolymer stabilised soils tend to retain more water compared to unamended soils. This property of biopolymers to retain more water within soil may aid the hygroscopic behaviour of biopolymer stabilised earthen construction materials and it is this topic which is the subject of the following sections.

#### 5.4.1. Test methodology

To assess the hygroscopic behaviour of biopolymer stabilised earthen construction materials, the moisture buffering values (See 2.2.4.3) of these materials were compared with unamended and cement stabilised materials. As discussed in Chapter 2, though there are different test procedures to obtain moisture buffering values, the most commonly used method for earthen construction materials is the NORDTEST method (McGregor et al., 2016). It was considered appropriate to follow the NORDTEST for the present investigation, so that the moisture buffering values of biopolymer stabilised specimens could be easily compared with other reported literature data. As per the NORDTEST, the minimum exposed surface area of the specimen should be 0.010 m<sup>2</sup>, in order to satisfy this test requirement, cylindrical specimens of 50 mm diameter and 100 mm length were considered. During the test, the cylindrical specimens are placed in disposable aluminium cups exposing its top and lateral surfaces while sealing its bottom surface (Figure 5.14b). Under this condition, the exposed surface area for a cylinder would be about 0.018 m<sup>2</sup> which is higher than the minimum requirement. Three identical specimens were prepared for unamended, cement and biopolymer stabilised samples. For biopolymer stabilised specimens, the stabiliser content was maintained at 2.0% of the dry soil mass, while for cement stabilised samples it was 8.0% of dry soil mass. Cylindrical samples were prepared according to the procedure described in Section [5.2.2.3](#).

## Chapter 5. Assessment as building material

Further in order to investigate the influence of sample scale on the hygroscopic properties of the material, a comparison of hygroscopic behaviour was made between cylindrical samples and bricks for biopolymer stabilised specimens. For both biopolymers, bricks were prepared according to the procedure described in Section 5.2.2.4. For the bricks, all but one largest face (200 mm x 100 mm) was sealed using aluminium tape to obtain an exposed surface area of 0.020 m<sup>2</sup> (Figure 5.14c). After preparation, all samples were left to cure for 28 days in laboratory atmosphere with relative humidity of 50% and temperature of 23°C. Practically, cement stabilised earthen materials are wet cured in order to maximise the efficiency of cement stabilisation. It was considered that it would be appropriate to compare the hygroscopic behaviour of cement stabilised samples in these conditions. Hence, cement stabilised cylinders were wet cured by ensuring they stay moist by wrapping the samples by wet cloth. The temperature during the test was maintained constant at 23°C. It is important to note here that the effect of temperature on moisture buffering tests is negligible for temperatures between 20°C and 70°C (Kast and Jokisch, 1972; Padfield and Jensen, 2011). Moisture buffering tests were performed inside the climatic chamber CLIMATS Type EX2221-HA at SIAME Laboratory in UPPA (Figure 5.16a).



(a)



(b)



(c)

Figure. 5.16. Moisture buffering tests, (a) Climatic chamber and (b) Cylindrical samples and (c) Brick samples

## Chapter 5. Assessment as building material

Prior to the start of the test, the initial dimensions of all samples were recorded and samples were then left to equalise under a temperature of 23°C and relative humidity of 33% until the observed mass variation of a sample was less than 0.1%. All samples took about 15-18 days to equalise under the set ambient conditions. After equalisation, sample dimensions were noted for any variation with the initial dimensions. The samples were then exposed to cycles of a high humidity level of 75% RH for 8 hours and followed by a low humidity level of 33% RH for 16 hours as per the NORDTEST requirements. Sample masses were recorded at regular intervals by means of a weighing scale having a resolution of 0.01 grams. After all samples reached two stable cycles, they were removed from the climatic chamber and their final dimensions were recorded. For the stable cycle, the  $MBV_{\text{practical}}$  for a given material is determined using equation (2.1).

### 5.4.2. Test results

#### 5.4.2.1. Moisture absorption curves

The results of moisture buffering tests are presented in the form of moisture absorption curves. Moisture absorption is defined as ratio of mass variation (i.e. difference in sample mass between two different readings) to its exposed surface area. Total exposed surface area of each sample was calculated based on their measured dimensions. At the end of moisture buffering test, it was observed that all samples had negligible variation between initial and final dimensions. Figure 5.17 shows moisture absorption curves for all cylindrical samples, while Figure 5.16 shows moisture absorption curves for biopolymer stabilised samples for both cylindrical and brick samples.

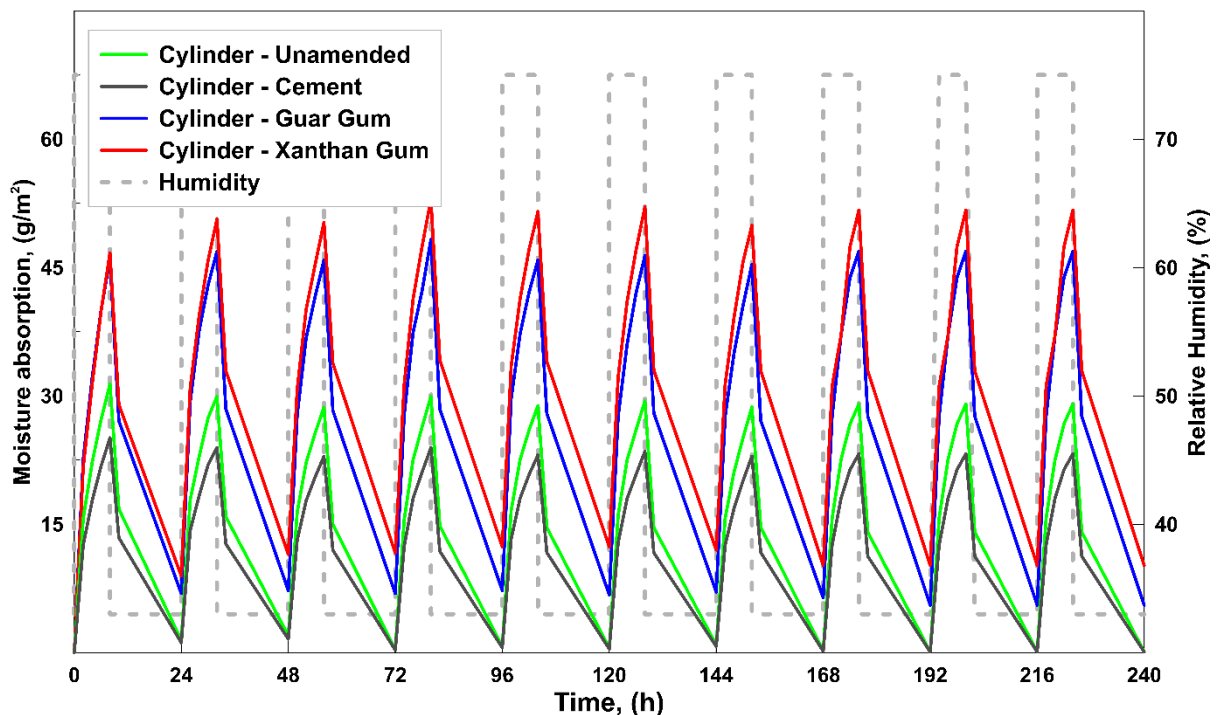

Figure. 5.17. Moisture absorption versus time for all cylindrical samples

## Chapter 5. Assessment as building material

From Figure 5.18, it can be observed that, for all samples after initial two cycles, the amount of water absorbed during high humidity (uptake) is equal to the amount of water released (release) during low humidity. At this condition, the material is said to be in equilibrium with the selected humidity conditions and for this condition the moisture buffering value of the material can be determined. Comparing cylindrical and brick samples for both biopolymers (Figure 5.16), bricks took longer to achieve equilibrium. This may be due to the sample geometry and direction in which moisture movement (i.e. adsorption and desorption) occurs. In the case of cylinders, the moisture movement occurs across the lateral radial and top surfaces of the cylinder, this would ensure that the interior parts of the cylinder achieve equilibrium quickly. In the case of a brick, where all but one surface is sealed, moisture movement occurs only in one direction and hence more time may be needed to ensure the lower portion of the brick (i.e. the portion adjacent to the sealed surface) is in equilibrium.

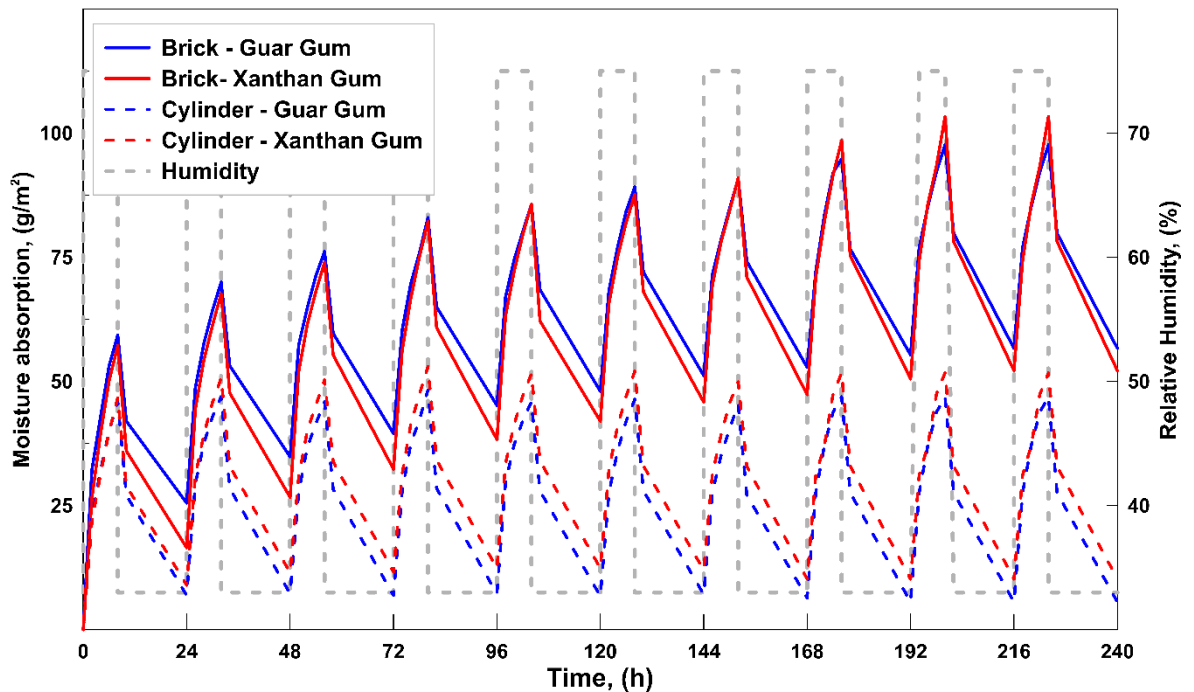

Figure. 5.18. Moisture absorption versus time for all biopolymer stabilised samples

Figures 5.19a and 5.19b show the moisture absorption curves at the last stable cycle for both guar gum and xanthan gum stabilised samples respectively. Moisture absorption curves for unamended and cement stabilised samples are also plotted. It can be noted from these figures, at the given ambient conditions, biopolymer stabilised earthen materials retain more water within the soil matrix than unamended and cement stabilised earthen materials. Moisture absorption of unamended samples is primarily dependent on the clay mineral present in the soil mix, i.e. kaolinite. Having least affinity towards water, it can be expected that the amount of moisture absorbed by unamended samples would be correspondingly low (McGregor et al., 2014). In the case of cement stabilised samples, the addition of cement leads to the formation of

## Chapter 5. Assessment as building material

cementitious products which cover the clay surface and thus reduce the moisture absorption capabilities (Arrigoni et al., 2017). In the case of biopolymer stabilised samples, in addition to the clay activity, the ability of hydrogels to absorb or diffuse moisture under varying ambient conditions may affect moisture absorption (Kocherbitov et al., 2010). Having natural affinity towards water, it can be expected that the biopolymer stabilised earthen materials will absorb more water at higher humidities. Between the biopolymers, xanthan gum stabilised samples have slightly higher moisture absorption than guar stabilised samples. These results concur with the observed soil-water retention behaviour of biopolymer stabilised soils as discussed in Chapter 4, which clearly show that xanthan gum retains more water than guar gum over a range of water contents. With better moisture retention capabilities, it is therefore no surprise that both guar and xanthan gum stabilised earthen materials have retained more moisture during the test.

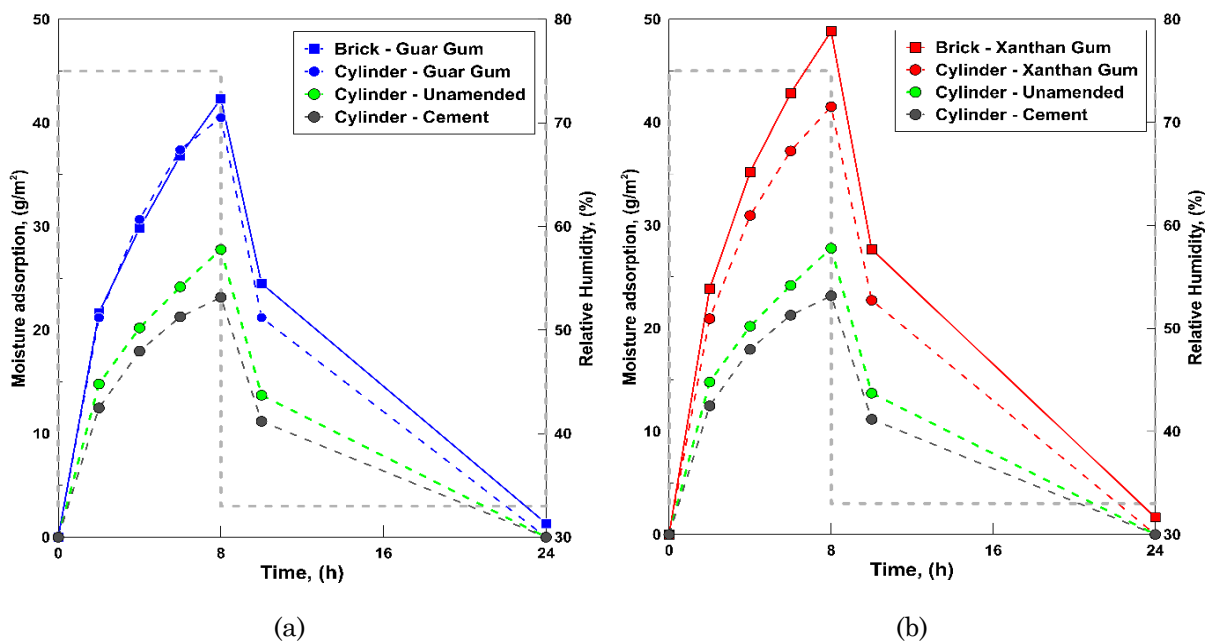

Figure. 5.19. Comparison of moisture adsorption for the last stable cycle, (a) guar gum and (b) xanthan gum

### 5.4.2.2. Moisture buffering value

The *characteristic* moisture buffering value of a material is the one which has same MBV value during the uptake and release portions of the humidity cycle (i.e,  $MBV_{\text{uptake}}$  is equal to  $MBV_{\text{release}}$ ). To determine this parameter, moisture buffering values during uptake and release over the cycles in the tests have been plotted for both guar and xanthan gum stabilised specimens along with unamended and cement stabilised specimens in Figures 5.20 and 5.21 respectively. For the final characteristics moisture buffering values obtained, a comparison is made for all specimens considered in this study in Figure 5.20.

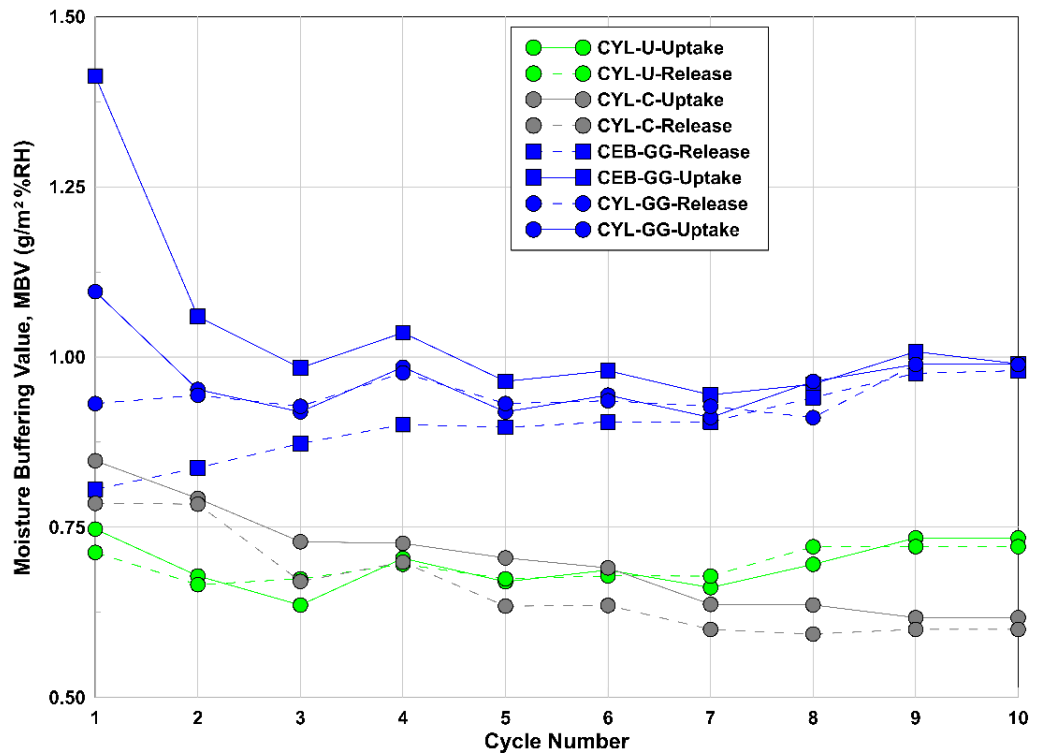

Figure. 5.20. Moisture buffering value (uptake versus release) – guar gum samples

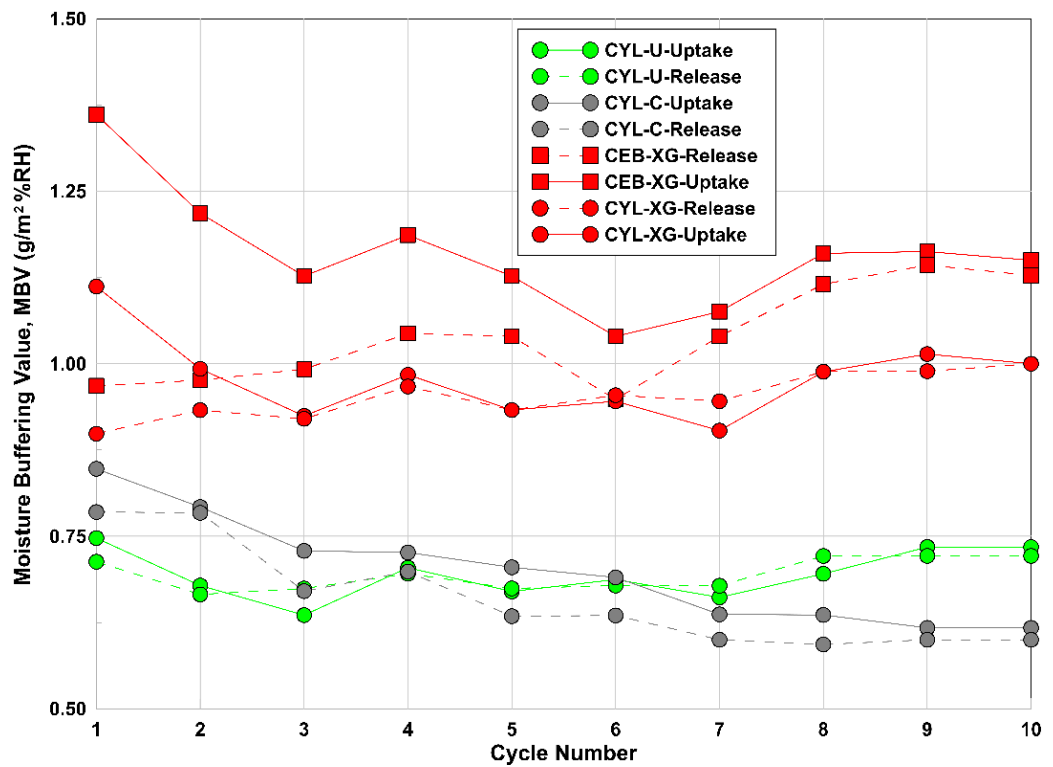

Figure. 5.21. Moisture buffering value (uptake versus release) – xanthan gum samples

It can be observed from Figure 5.22, that the final moisture buffering values of biopolymer stabilised samples are higher than unamended and cement stabilised samples. With lower

moisture absorption capabilities it can be expected that the moisture buffering values of cement stabilised samples are lesser than unamended samples. This is in concurrence with the literature which states that cement stabilisation of earthen materials reduces the moisture buffering value and thus its hygroscopic behaviour (McGregor et al., 2014; Arrigoni et al., 2017). However, it is interesting to note that unlike cement stabilisation, biopolymer stabilisation improves the hygroscopic properties of the earthen material as judged by the increase in MBV. As noted previously, the interactions of hydrogels with moisture due to changes in ambient conditions enables it to retain more water leading to its improved hygroscopic behaviour. This is an important finding further supporting the practical use of biopolymer stabilisation considering that while the addition of cement improves mechanical and durability properties, it comprises the hygroscopic properties of the earthen construction material. As an alternative to cement, biopolymers appear to be prospective alternative stabilisers which not only provide necessary mechanical and durability properties, but also improve the hygroscopic behaviour of earthen construction materials.

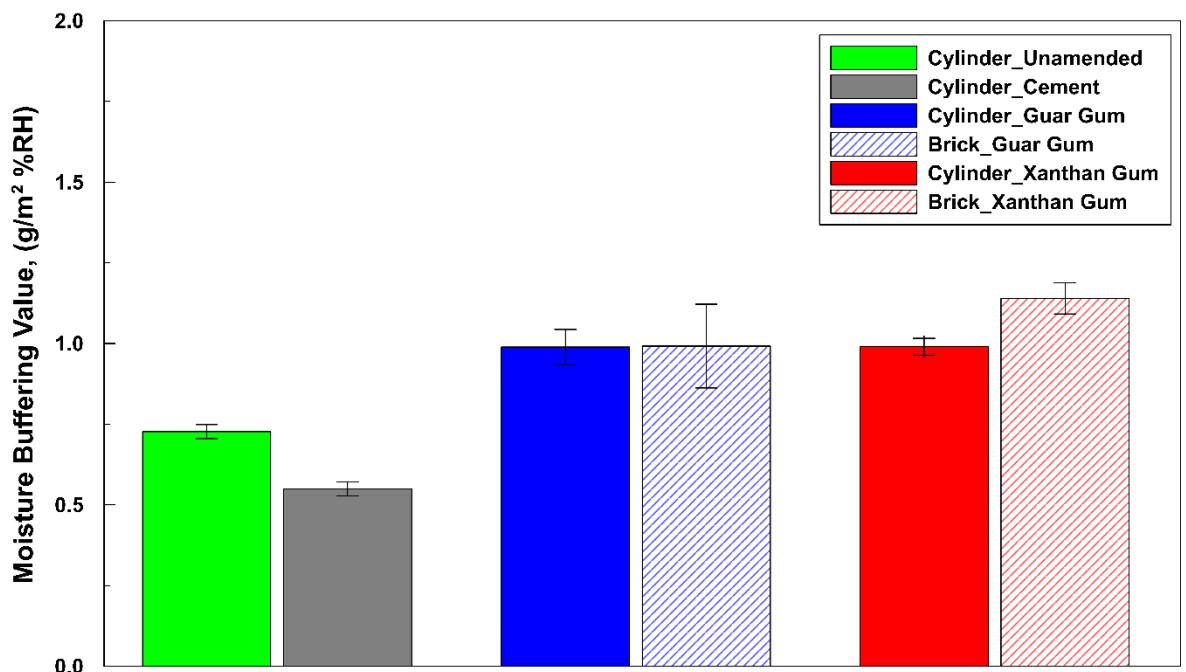

Figure. 5.22. Moisture buffering value (MBV<sub>practical</sub>) for all samples

Figure 5.23 presents the moisture buffering values of all the tested samples along with other materials taken from the literature. In this comparison, moisture buffering values of test specimens determined only through the NORDTEST method have been considered. A comparison is made with the moisture buffering values of fired brick and concrete as determined by Rode et al., (2005). Further, MBV values of earthen construction materials as determined by Allinson and Hall, (2012), McGregor et al., (2014; 2014), Oudhof et al., (2015). Arrigoni et al., (2017) are also plotted along with the MBV classification as proposed by Rode et al., (2005). The moisture buffering values for the specimens tested in this study varied from 0.55 – 1.05 g/m<sup>2</sup>%RH, and with these values most of the samples tested can be classified into the “moderate”

## Chapter 5. Assessment as building material

category, and only the xanthan gum stabilised brick falls into “good” category (Figure 5.21). It can be noted from the figure that the hygroscopic properties of biopolymer stabilised earthen construction materials are better than some conventional building materials such as fired brick and concrete. Also, in concurrence to the findings of McGregor et al. (2014) and Arrigoni et al. (2017), the moisture buffering values of cement stabilised samples from the present study were found to be lower than for the unamended samples. At the same time, it can be observed that the moisture buffering values of unamended and cement stabilised samples from the present study seem to be lower than the reported values in the literature. These lower values may be attributed to the factors which control hygroscopic properties of earthen materials, i.e. soil gradation and principal clay mineral in the soil mix. It is well known that under similar hygrothermal conditions, finer soil particles retain more water than coarser particles (Jaquin et al., 2008; Beckett and Augarde, 2012). Hence, higher percentages of fine particles in the soil mix would contribute to higher moisture buffering values. The reported higher moisture buffering values of compressed earth blocks by McGregor et al., (2014) could therefore be attributed to a difference in percentage of clay than the material in the current study.

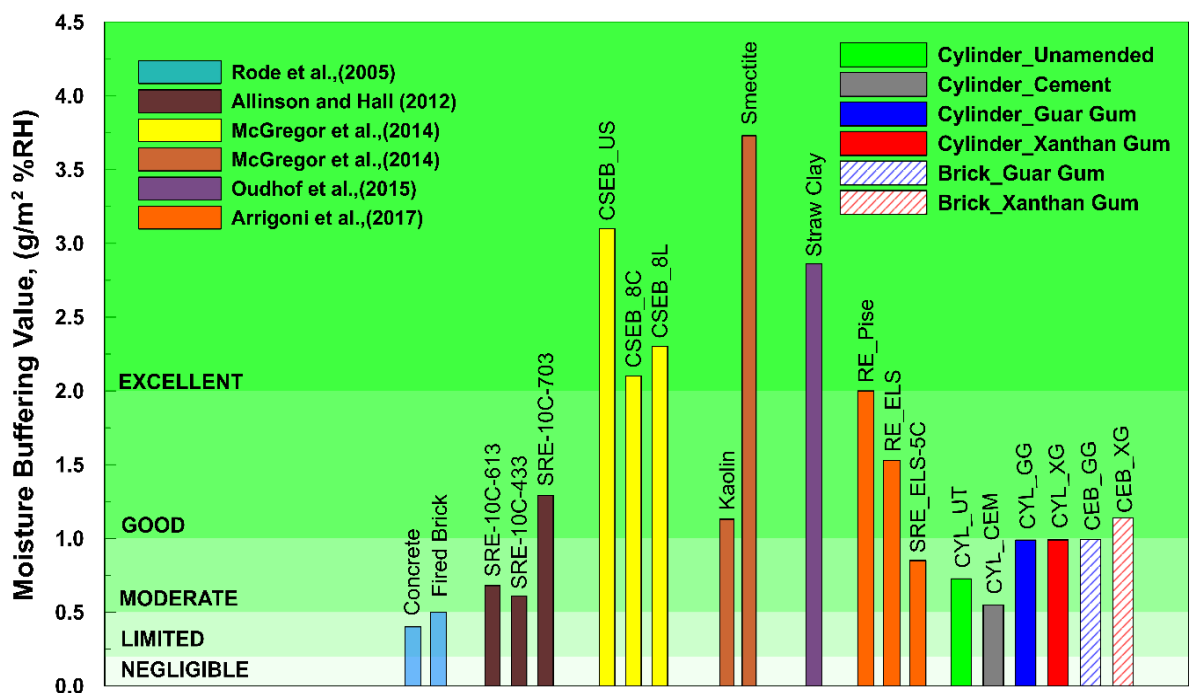

Figure. 5.23. Comparison of moisture buffering values of present study with literature data

Arrigoni et al.,(2017) studied the effect of chemical stabilisers on the hygroscopic properties of stabilised rammed earth materials prepared also using an engineered soil mixture and moisture buffering values were obtained also for a natural soil. It can be noted from Figure 5.21, the hygroscopic properties of the earthen construction material prepared with natural soil (denoted as RE\_Pise) is quite high in comparison with those prepared with engineered soil mix (ELS). Further, the addition of cement has even more reduced the moisture buffering value of

## Chapter 5. Assessment as building material

---

the material. From this study it is evident that the type of soil used for manufacturing earthen construction materials controls its hygroscopic behaviour, which is of course somewhat obvious. In the present study, the earthen construction materials were also prepared using an engineered soil mix consisting of a clay fraction of refined kaolin. Refined kaolin was preferred over natural kaolinitic soils primarily to control the effect of clay mineralogy while understanding the behaviour of biopolymer stabilisation; a similar approach has been considered in past studies of earthen construction materials (Liuzzi et al., 2013; Corbin and Augarde, 2015). By using refined kaolin, however, the engineering behaviour of the prepared soil may be atypical to that of natural soil due to its defined particle size gradation and plasticity properties (Rossato et al., 1992). Having only kaolinite as the dominant clay mineral, which has least affinity towards water of the clay minerals (Etzion and Saller, 1987), it can be expected that moisture buffering values of the material prepared here to be lower than those of materials prepared with natural soils. Clearly, further work is necessary to assess the behaviours of biopolymer stabilisation on earthen materials with different dominant clay minerals, but the results to date are encouraging.

### 5.5 Recyclability potential of earthen construction materials.

Unlike unstabilised earthen construction materials, which can be easily recycled by being broken up, chemically stabilised materials can present issues for recycling (Gallipoli et al., 2017). Cement stabilised earthen construction materials are usually downcycled rather than getting completely recycled, due to the high energy intensive processes involved to recycle it and retrieve back the original soil properties (Schroeder, 2016). As noted in Chapter 3, the stabilisation process for both the biopolymers is different from cement, where stabilisation is achieved through “hydrogels” rather than cementitious products. Considering the physical characteristics of hydrogels, lower energy intensive processes may be needed to recycle biopolymer stabilised earthen construction materials. If biopolymer stabilised materials require less energy intensive processes to recycle, that may become attractive and economically viable building material leading to lower production of construction waste. In this section a brief study of the recycling potential for biopolymer stabilised earthen construction materials is presented.

#### 5.5.1. Materials

The tile specimens used in the durability tests detailed in Section [5.3.1](#) were used to assess the recyclability potential of biopolymer stabilised earthen construction materials. The aim of recyclability tests was to compare physical properties of the recycled material with the original engineered soil mix which comprised 20% kaolin, 70% sand and 10% gravel by mass.

### 5.5.2. Recycling Procedure

True recycling of earthen construction materials means retrieval of the original desired soil properties, i.e. soil gradation and plasticity, so that it can be re-used again for earthen construction (Schroeder, 2016). To achieve this, soil washing, a water-based process which separates the coarse soil fraction from finer particles was considered in this study (Griffiths, 1995). The surface of the tiles was cleaned off using a wire brush. The tiles were then broken down gently into smaller pieces using a wooden mallet. A known mass of this disintegrated earthen material was soaked in deionised water. After 1 hour of soaking, any lumps of soil were disintegrated manually and a slurry consistency was achieved. The slurry was then left to settle for 24 hours before being tested for particle size analysis, Atterberg limits and linear shrinkage tests. Additionally, chemical tests were performed on the water collected after soil washing.

### 5.5.3. Test method and results

#### 5.5.3.1. Particle size analysis

The prepared slurry was washed through a 63  $\mu\text{m}$  sieve to separate the coarse fraction of the soil mixture from the finer particles. Both soil fractions were then oven dried at  $100 \pm 5^\circ\text{C}$  for 24 hours, after which, the dried coarse fraction was weighed and particle size variation was obtained through dry sieve analysis as per BS 1377-2 (1990). Sedimentation analysis by the pipette method was performed for the fine fraction of the soil mixture as per BS 1377-2 (1990). Particle size distributions were obtained for both biopolymer stabilised soils and the unamended soil mixture and the results are plotted in Figure 5.22.

From Figure 5.24, it can be noted that the recycled soil mixtures have larger coarser fractions and smaller finer fractions in comparison to the unamended soil mixtures. These larger coarser fractions of the recycled soil mixtures can be attributed to the formations of soil agglomerations due to biopolymer stabilisation (Latifi et al., 2017). On recycling much of these agglomerations have however disintegrated for the guar gum stabilised soil mixture, while many agglomerations have remained intact for the xanthan gum stabilised soil mixture. Compared to guar gum, xanthan gum form ionic bonds with clay particles in addition to hydrogen bonds which are chemically stronger (Chen et al., 2013; Chang et al., 2015). Due to these additional stronger bonds, xanthan stabilised soil mixture could be expected to have many agglomerations which resist washing, certainly under these test conditions. In both cases, the recycled soil mixture cannot be used as it is again for preparing earthen construction materials as per the recommendation given by MOPT (1992) and AFNOR(2001), however slight modifications to the recycled soil mixtures would ensure that the soil gradation falls within the recommended limits. Certainly were a soil mix chosen more to the middle of the allowable range, recycling would appear to be directly possible.

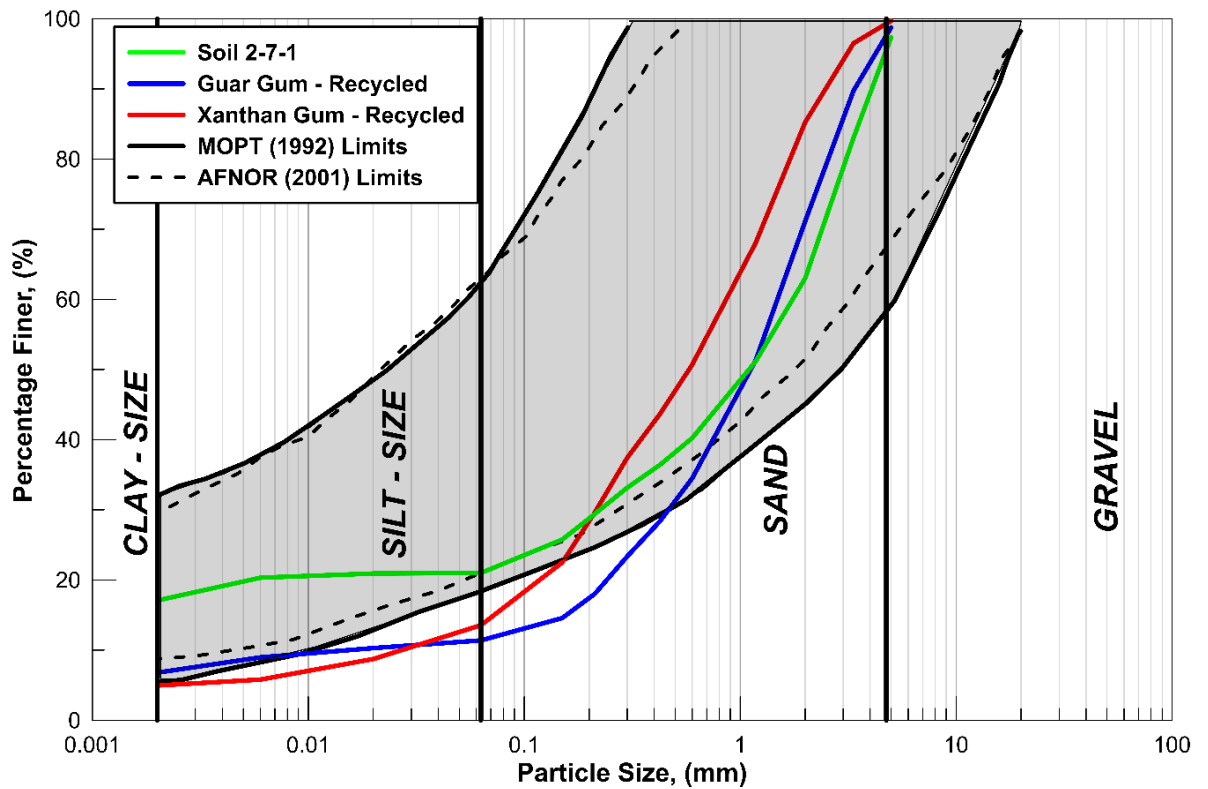

Figure. 5.24. Comparison of particle size distribution of engineered soil mix with recycled soil mixes

### 5.5.3.2. Atterberg limits and Linear Shrinkage tests

For these tests, the recycled soil mixtures slurry as mentioned in Section 5.5.2 was placed on a 425  $\mu\text{m}$  sieve and washed thoroughly using deionised water. Washing was continued until clear water and no visible soil fines passed through the 425  $\mu\text{m}$  sieve. The soil fraction passing was collected and oven dried for 24 hours at  $100 \pm 5^\circ\text{C}$ . After 24 hours, the dried soil fraction was broken down into smaller fractions and mixed thoroughly with deionised water until a stiff consistency was achieved. This mixture was left to equilibrate in air-tight polythene bags for 24 hours, after which Atterberg limits and linear shrinkage tests were performed as per BS 1377-2 (1990). The results are presented in Figures 5.23 and 5.24 respectively.

Figure 5.25 presents plasticity characteristics of unamended, stabilised and recycled earthen materials along with standard recommendations for earthen materials (Houben and Guillaud, 1994; AFNOR, 2001). The liquid and plastic limits of the unamended soil mixture were 36.1% and 18.7% respectively. When the soil mixture was stabilised with 2.0% biopolymer content, the Atterberg limits for both biopolymer stabilised soils increased and this increase was more significant for guar gum stabilised soils. The fines fraction of the soil mixture was initially classified as CI i.e., clay of intermediate plasticity. In the biopolymer stabilised soils, for guar gum, the fines fraction of the soil mixture was classified as CH i.e., clay of high plasticity, while for xanthan gum it was classified as CI. These differences in Atterberg limits for guar and

xanthan stabilised soils are mainly due to the different stabilizing mechanisms of the biopolymers (as discussed in Chapter 3).

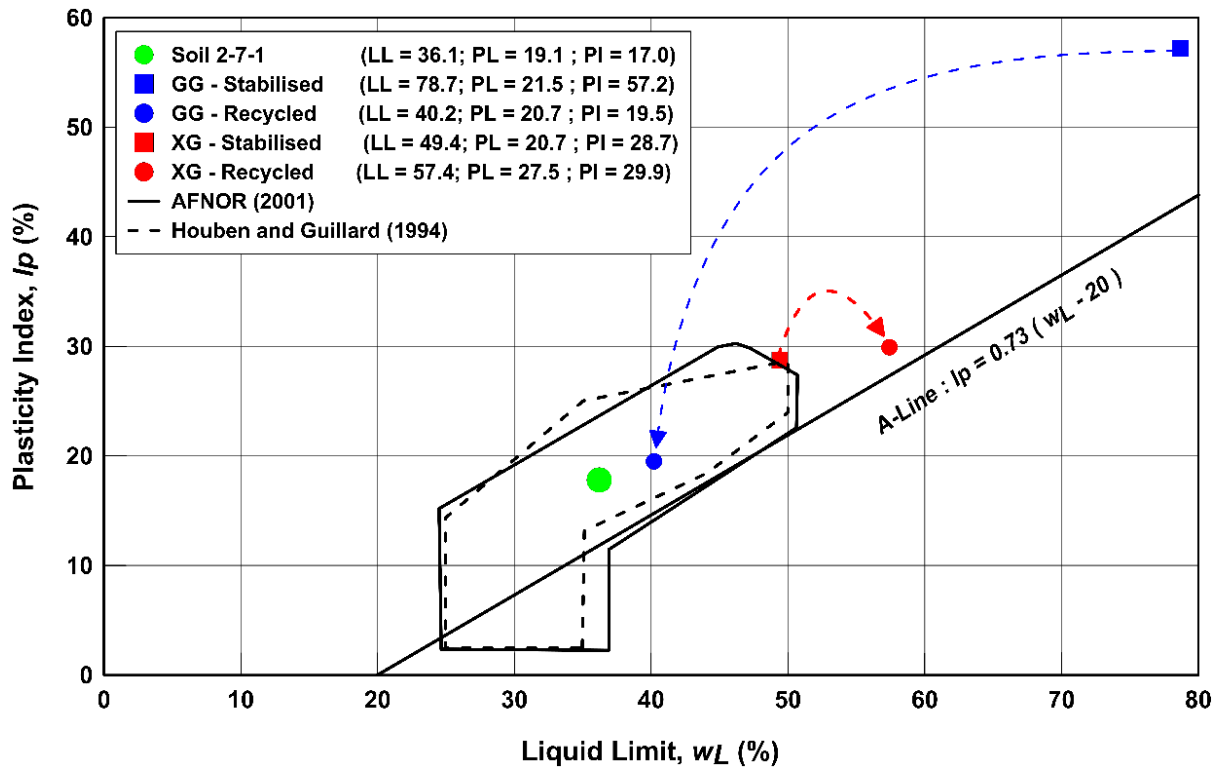

Figure 5.25. Plasticity properties of the unamended, stabilised and recycled material

Compared to xanthan gum, guar gum has higher affinity towards water (Nugent et al., 2009) and this may have led to the higher water contents at Atterberg limits for the guar gum stabilised soil mixture. After recycling, the plasticity properties of the guar gum stabilised specimens were similar to that of the unamended soil mixture. As indicated the primary bonding for guar gum stabilised soils is achieved only through hydrogen bonds and on recycling these bonds are easily broken and the stabilisation is lost (Nugent et al., 2009; Chen et al., 2013). Thus, the stabilised material can be recycled easily ensuring the original plasticity characteristics of the soil mixture are retrieved back.

In the case of the xanthan gum stabilised soil mixture, bonding of the soil particles occurs via a different mechanism (as discussed above) and with these bonds, the xanthan gum stabilised soil mixture may form a complex network of soil agglomerations, thus stabilising soil and trapping free water (Chen et al., 2013). Interestingly, the Atterberg limits of the recycled soil mixture were different to the stabilised soil mixture, changing the fines fraction classification to CH. As noted in the previous section, even after soil washing, it appears that many soil agglomerations remained stable. At the liquid limit, these agglomerations require more water for remoulding to achieve the liquid limit consistency. Hence, the observed liquid limit for recycled soil mixture is higher than that of stabilised soil mixture. However, the plastic limits for both the stabilised and recycled soil mixtures were similar.

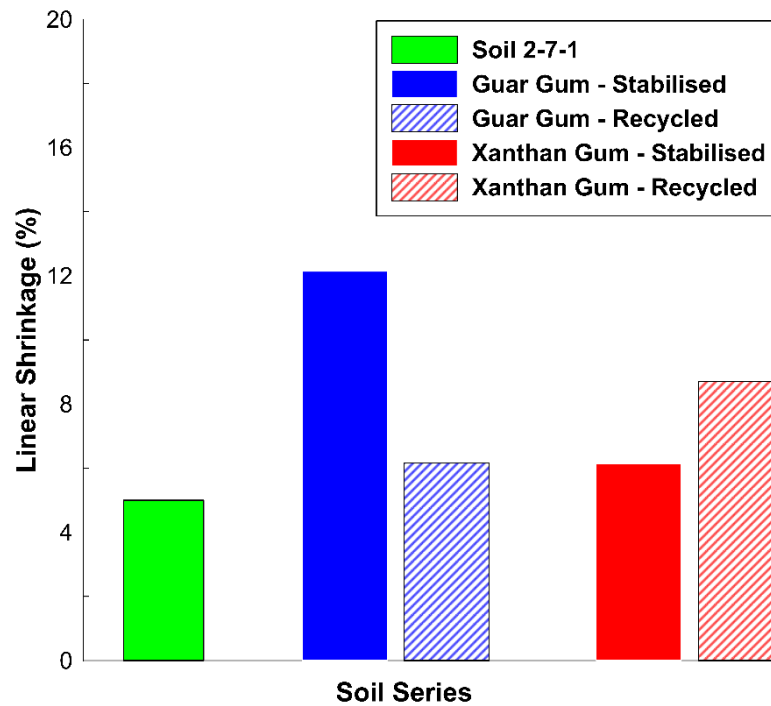

Figure 5.26. Variation of Linear Shrinkage

Switching to shrinkage tests, it can be observed that the linear shrinkage of the unamended soil mixture was 5.0% (see Fig 3) while the linear shrinkage of the guar gum stabilised samples was higher. This increased value of linear shrinkage may be linked to the high affinity of guar gum towards water (Nugent et al., 2009) leading to formation of hydrogels through hydrogen bonding. However, on recycling, these bonds are removed and thus the recycled material has similar linear shrinkage value as that of the unamended soil mixture at 6.2%. In the case of xanthan gum, the additional stronger ionic bonds with weaker hydrogen bonds has led to more stable soil agglomerations and hence the lower shrinkage value. On recycling, the outer chains of hydrogel which primarily bond through hydrogen bonding may have been completely removed and at the same time the soil agglomerations which are bonded through stronger ionic bonds may have been disturbed. Further as noticed from particle size distribution, lesser clay fraction of the soil mix is available after washing. With lesser clay content to bind the soil particles and weakly linked soil agglomerations, the soil mix may be susceptible to volumetric changes on drying. This hypothesis is supported by the higher linear shrinkage value of the recycled material as observed in Figure 5.26.

### 5.5.3.3. Chemical tests on water

In a real life scenario, the water used for washing a soil during recycling would need to be safely disposed of or treated. This requires us to understand the effect of the presence of the biopolymers on the water used for soil washing to ensure its safe disposal. In order to understand this, the surplus surface water of the slurry which was left to settle for 24 hours (mentioned above) was collected in air-tight 250 mL Duran bottles and stored in a dark environment at

## Chapter 5. Assessment as building material

21°C. Chemical properties of these water samples were then tested after 1 and 7 days respectively. Standard chemical tests such as pH, oxidation reduction potential (ORP), dissolved oxygen (DO) and electric conductivity tests were performed using a HANNA digimeter with respective probes. The results were compared with the chemical properties of tap water and World Health Organisation (WHO) recommendations (2011).

Table 5.5. presents the chemical properties of the water samples collected on the 1st and 7th days after recycling. The chemical properties suggest that compared to tap water, pH for water collected for washing guar and xanthan gum stabilised soils is slightly more alkaline. Lower ORP and DO values on the 7th day indicate that the water used for recycling for both biopolymers may be prone to microbial activity which has consumed the dissolved oxygen in the water. Electric conductivity results, which are an indirect measurement of total dissolved solids, indicate that there is slight increase of dissolved solids for xanthan gum treated water, while the increase in guar gum treated water is negligible. However, it can be concluded that no special disposal treatment may be necessary if the water is disposed immediately after washing.

Table 5.5. Results for the chemical tests of water

| Test Conducted                     | Tap water |      | Guar gum |      | Xanthan gum |      | WHO     |
|------------------------------------|-----------|------|----------|------|-------------|------|---------|
|                                    | 1d        | 7d   | 1d       | 7d   | 1d          | 7d   |         |
| pH                                 | 6.9       | 6.7  | 7.7      | 7.0  | 7.9         | 6.5  | 6.5-9.5 |
| ORP (mV)                           | 291       | 96.7 | 278      | 12.4 | 302         | 55   | -       |
| DO (mg/L)                          | 6.6       | 6.4  | 6.1      | 1.1  | 6.7         | 1.7  | 10-12   |
| Temperature (C)                    | 19.8      | 19.9 | 20.4     | 20   | 20.5        | 19.9 | 15      |
| Electric Conductivity( $\mu$ s/cm) | 181       | 199  | 135      | 153  | 127         | 239  | <1500   |

### 5.5.4. Discussion on test results

Based on the test results, it can be concluded that the soil washing technique used was sufficient to recycle and retrieve back much of the original soil gradation and plasticity properties for guar gum stabilised samples. For xanthan gum stabilised samples, the soil washing technique was not so successful in recycling it completely. The recycled material resisted washing, leading to a higher coarser fraction. Furthermore, the original plasticity properties of the soil were not retrieved and the recycled material had higher plasticity properties than unamended soil mixture(i.e. liquid limit and linear shrinkage values). In both cases, the water collected after washing showed an increased demand for oxygen with time indicating potential microbial activity. Thus, it would be appropriate to dispose the water immediately after washing to ensure

safe disposal. Clearly, the results here relate to a single reuse of these materials and to a particular washing procedure however, as an alternative to cement, biopolymers may have potential not only in improving the strength and durability of earthen construction material, but also has potential for recycling.

### 5.6. Concluding remarks

Based on the experimental findings key research conclusions on durability performance, hygroscopic behaviour and recyclability potential of biopolymer stabilised earthen construction materials are summarised below:

#### 1. Durability tests

- a. Results from contact and suction tests indicate that the compressed earth blocks without any amendment performed satisfactorily against capillary action of water. This is primary due to the nature of clay mineral present in the engineered soil mix used to prepare the brick. Being less susceptible against cracking, artificial kaolin was able to withstand against deterioration under capillary action of water.
- b. The beneficial effect of biopolymer stabilisation was more evident for adverse durability tests such as erosional resistance and dip tests. For these tests, unamended earthen construction materials failed to satisfy the test requirements, while biopolymer stabilised earthen construction materials performed well.
- c. In erosion resistance tests, biopolymer stabilised earthen construction materials with higher percentages of xanthan gum had lower depths of erosion. Also, the observed rate of erosion was lesser for xanthan gum stabilised samples. Between biopolymers, xanthan gum has better stabilisation effect to improve durability properties of the stabilised earthen materials.
- d. Based on the recommendation given by NZDS 4298 (1998), precise durability performance of biopolymer stabilised earthen materials against erosion may be performed through spray tests, as the observed depth of erosion in Geelong tests was less than 5.0 mm.
- e. In case of dip tests, the observed loss of mass for unamended bricks was higher than 15.0%, while for the biopolymer stabilised bricks the loss of mass was negligible.
- f. Based on the classification of DIN 18945 (2013), unamended compressed earth blocks can be classified as Class III brick suitable for dry applications, while compressed earth bricks stabilised either through guar gum or xanthan gum can be classified as Class Ia suitable for external wall exposed to natural weathering.

#### 2. Hygroscopic behaviour

- a. Moisture buffering values of all the test samples tested in this study were higher than conventional building materials such as fired brick and concrete. The moisture buffering

values for biopolymer stabilised samples are nearly twice to that of conventional building materials.

- b. The results from moisture buffering tests are in concurrence with previous literature findings that the addition of cement reduces the hygroscopic behaviour of the stabilised earthen construction materials.
  - c. Unlike cement, addition of biopolymers improved the hygroscopic properties of the earthen construction materials. The observed moisture buffering values of biopolymer stabilised earthen materials were higher than both unamended and cement stabilised bricks.
  - d. As per Rode et al., (2005) MBV classificaton, most of the tested samples can be classified into “moderate” category, while only xanthan gum stabilised brick falls into “good” category.
3. Recycling potential
- a. Simple washing technique which is typically employed in geotechnical applications can be employed to recycle and retrieve original soil properties for guar gum stabilised earthen material.
  - b. For xanthan gum stabilised earthen material, soil washing technique was not entirely successful to recycle it completely. The recycled material resisted washing leading to coarser fractions.
  - c. Based on the chemical tests on water which was used for washing it may be concluded that the water if disposed immediately it may not pose any environmental concerns.
  - d. Biopolymers may have potential not only in improving the strength and durability of earthen construction material, but also has potential for recycling. This would enable the completion of life cycle of the earthen material without generation of construction waste.

### References

- AFNOR. 2001. XP P13-901; Compressed earth blocks for walls and partitions: definitions – Specifications – Test methods – Delivery acceptance conditions.
- Allinson D, and Hall M. 2012. Humidity buffering using stabilised rammed earth materials. *Proceedings of the Institution of Civil Engineers - Construction Materials*, 165(6), 335–344.
- Arrigoni A, Grillet AC, Pelosato R, Dotelli G, Beckett C, Woloszyn M, and Ciancio D. 2017. Reduction of rammed earth's hygroscopic performance under stabilisation: an experimental investigation. *Building and Environment*, 115, 358–367.
- ASTM-D559. 1989. Wetting and Drying Compacted Soil- Cement Mixtures. Philadelphia: American Society for Testing and Materials.
- Beckett C, and Augarde C. 2012. The effect of humidity and temperature on the compressive strength of rammed earth. In *Unsaturated Soils: Research and Applications* (pp. 287–292). Berlin, Heidelberg: Springer Berlin Heidelberg.
- Bruno AW. 2016. Hygro-mechanical characterisation of hypercompacted earth for sustainable construction, 166.
- BS 1377-2. 1990. Methods of test for Soils for civil engineering purposes - Part 2: Classification tests. London: BSI.
- BS 3921. 1985. Specification for Clay Bricks. London: BSI.
- BS ISO. 2000. BS ISO 15686-1:2000 - Buildings and constructed assets - Service life planning. Part 1: General principles, 54. Retrieved from <https://bsol-bsigroup.com.ezproxy.napier.ac.uk/Bibliographic/BibliographicInfoData/00000000030029472>
- Bui QB, Morel JC, Venkatarama Reddy B, and Ghayad W. 2009. Durability of rammed earth walls exposed for 20 years to natural weathering. *Building and Environment*, 44(5), 912–919.
- Calkins M. 2008. *Materials for Sustainable Sites: A Complete Guide to the Evaluation, Selection, and Use of Sustainable Construction Materials*. John Wiley & Sons.
- Chang I, Im J, Prasadhi AK, and Cho G-C. 2015. Effects of Xanthan gum biopolymer on soil strengthening. *Construction and Building Materials*, 74(10), 65–72.
- Chen R, Zhang L, and Budhu M. 2013. Biopolymer Stabilization of Mine Tailings. *Journal of Geotechnical and Geoenvironmental Engineering*, 139(10), 1802–1807.
- Ciurileanu GT, and Horvath IB. 2012. Modular Building Using Rammed Earth. *Acta Technica Napocensis: Civil Engineering & Architecture*, 55(2), 173–181.
- Corbin A, and Augarde C. 2015. Investigation into the shear behaviour of rammed earth using shear box tests. In *Proceedings of the First International Conference on Bio-based Building Materials*. Clermont-Ferrand, France: RILEM. Retrieved from <http://www.rilem.org/gene/main.php?base=500218>
- DIN18945. 2013. Earth blocks - Terms and definitions, requirements, test methods.
- Eassey A. 1997. *The Effect of the Angle of Raindrops on Earthwall Buildings*. University of Technology Sydney.
- Etzion Y, and Saller M. 1987. Earth Construction—A Review of Needs and Methods. *Architectural Science Review*, 30(2), 43–48.
- Frencham GJ. 1982. *The Performance of Earth Buildings*. Deakin University, Geelong, Australia.
- Gallipoli D, Bruno AW, Perlot C, and Mendes J. 2017. A geotechnical perspective of raw earth building. *Acta Geotechnica*, 12(3), 463–478.
- Gallipoli D, Bruno AW, Perlot C, and Salmon N. 2014. *Raw earth construction: is there a role for unsaturated soil mechanics*. Taylor & Francis Group, London, UK.
- Graham N. 2011. *Guidelines for Drinking-Water Quality, 2nd edition, Addendum to Volume 1 – Recommendations*, World Health Organisation, Geneva, 1998, 36 pages (Vol. 1). Geneva: Urban Water.
- Griffiths RA. 1995. Soil-washing technology and practice. *Journal of Hazardous Materials*, 40(2), 175–189.
- Guettala A, Abibsi A, and Houari H. 2006. Durability study of stabilized earth concrete under both laboratory and climatic conditions exposure. *Construction and Building Materials*, 20(3), 119–127.
- Gulrez S, Al-Assaf S, and Phillips G. 2011. Hydrogels: methods of preparation, characterisation and applications. In *Progress in molecular and environmental bioengineering—from analysis and modeling to technology applications* (pp. 117–150). Intech.
- Heathcote KA. 1995. Durability of earthwall buildings. *Construction and Building Materials*, 9(3), 185–189.
- Houben H, and Guillaud H. 1994. *Earth construction: a comprehensive guide*. Intermediate Technology Publications.
- IS 1725. 2013. Indian Standard IS 1725: Stabilized soil blocks used in general building construction — Specification. New Delhi: Bureau of Indian Standards.

## Chapter 5. Assessment as building material

---

- Jaquin PA, Augarde CE, and Legrand L. 2008. Unsaturated characteristics of rammed earth. In First European conference on unsaturated soils, Durham, England (pp. 417–422).
- Kast W, and Jokisch F. 1972. Überlegungen zum Verlauf von Sorptionsisothermen und zur Sorptionskinetik an porösen Feststoffen (Considerations on the Course of Sorption Isotherms and Sorption Kinetics on Porous Solids). *Chemie Ingenieur Technik - CIT*, 44(8), 556–563.
- Kerali AG, and Thomas TH. 2004. Simple durability test for cement stabilized blocks. *Building Research & Information*, 32(2), 140–145.
- Kocherbitov V, Ulvenlund S, Briggner L-E, Kober M, and Arnebrant T. 2010. Hydration of a natural polyelectrolyte xanthan gum: Comparison with non-ionic carbohydrates. *Carbohydrate Polymers*, 82(2), 284–290.
- Latifi N, Horpibulsuk S, Meehan CL, Majid MZA, Tahir MM, and Mohamad ET. 2017. Improvement of Problematic Soils with Biopolymer—An Environmentally Friendly Soil Stabilizer. *Journal of Materials in Civil Engineering*, 29(2).
- Liuzzi S, Hall MR, Stefanizzi P, and Casey SP. 2013. Hygrothermal behaviour and relative humidity buffering of unfired and hydrated lime-stabilised clay composites in a Mediterranean climate. *Building and Environment*, 61, 82–92.
- McGregor F, Heath A, Fodde E, and Shea A. 2014. Conditions affecting the moisture buffering measurement performed on compressed earth blocks. *Building and Environment*, 75, 11–18.
- McGregor F, Heath A, Maskell D, Fabbri A, and Morel J-C. 2016. A review on the buffering capacity of earth building materials. *Proceedings of the Institution of Civil Engineers - Construction Materials*, 169(5), 241–251.
- McGregor F, Heath A, Shea A, and Lawrence M. 2014. The moisture buffering capacity of unfired clay masonry. *Building and Environment*, 82, 599–607.
- MOPT. 1992. Bases Para el Diseño y Construcción con Tapial. Madrid, Spain: Centro de Publicaciones., Secretaría General Técnica, Ministerio de Obras Públicas y Transportes.
- Morel J-C, Bui QB, and Hamard E. 2012. Weathering and durability of earthen material and structures. In *Modern Earth Buildings* (pp. 282–303). Elsevier.
- Morris H. 1994. Unpublished Comments for consideration on Draft Standard “Engineering Design of Earth Walled Buildings.” Joint Technical Committee Meeting BD/83 Earth Building.
- Nugent RA, Zhang G, and Gambrell RP. 2009. Effect of Exopolymers on the Liquid Limit of Clays and Its Engineering Implications. *Transportation Research Record: Journal of the Transportation Research Board*, 2101(1), 34–43.
- NZS 4298. 1998. Materials and workmanship for earth buildings [Building Code Compliance Document E2 (AS2)]. New Zealand Technical Committee. Wellington: Standards New Zealand.
- Ogunye FO, and Boussabaine H. 2002. Diagnosis of assessment methods for weatherability of stabilised compressed soil blocks. *Construction and Building Materials*, 16(3), 163–172.
- Oudhof N, Labat M, Magniont C, and Nicot P. 2015. Measurement of the hygrothermal properties of straw-clay mixtures. In *First International Conference on Bio-based Building Materials* (pp. 474–479).
- Padfield T. 1998. The role of absorbent building materials in moderating changes of relative humidity. Department of Structural Engineering and Materials, Lyngby, Technical University of Denmark.
- Padfield T, and Jensen L. 2011. Humidity buffering of building interiors by absorbent materials. In *9th Nordic Symposium on Building Physics - NSB 2011* (Vol. 1, pp. 475–482). Retrieved from [http://www.conservationsphysics.org/ppubs/humidity\\_buffering\\_building\\_interiors\\_nsb2011.pdf](http://www.conservationsphysics.org/ppubs/humidity_buffering_building_interiors_nsb2011.pdf)
- Rode C, Peuhkuri R, Mortensen LH, Hansens K, Time B, Gustavsen A, ... Harderup LE. 2005. *Moisture Buffering of Building Materials*, Report BYG•DTU R-126, ISSN 1601-2917. ISBN 87-7877-195.
- Rossato G, Ninis NL, and Jardine RJ. 1992. Properties of some kaolin-based model clay soils. *Geotechnical Testing Journal*, 15(2), 166–179.
- Schroeder H. 2016. *Sustainable Building with Earth. Sustainable Building with Earth*. Cham: Springer International Publishing.
- Terzaghi K, Peck BR, and Mesri G. 1963. *Soil Mechanics in Engineering Practice* (Third Edit). A Wiley-Interscience Publication.
- Walker P, Keable R, Martin J, and Maniatidis V. 2005. *Rammed earth: design and construction guidelines*. BRE Bookshop Watford.
- Yttrup P, Diviny K, and Sottile F. 1981. Development of a Drip Test for the Erodability of Mud Bricks. Deakin University.
-

# Chapter 6

## Conclusions

### 6.1 Chapter introduction

As a concluding chapter, major research findings of the thesis, implication of biopolymer stabilisation in geotechnical engineering and earthen construction, and potential future research are discussed. The main aim of the thesis was to identify a suitable bio-stabiliser for earthen construction materials, to understand the potential of the stabiliser through geotechnical characterisation and to assess the performance of bio-stabilised earthen construction material as a building material. In order to achieve this, different bio-stabilisation techniques which are currently used in different geotechnical applications were assessed. From these techniques, biopolymers were chosen as a potential stabiliser as they have a relatively simple application procedure and can be applied for different types of soil (Chang et al., 2016). Biopolymer stabilisation changes soil properties through hydrogels which are formed due to the interaction of biopolymer, soil and free water in the soil. On drying, the water molecules tend to escape from hydrogels leading to the formation of complex interconnected polymer chains which bind soil particles. In addition, during drying, the hydrogels transform from what is termed a 'rubbery' to a 'glassy' state (Eichler et al., 1997; Ayeldeen et al., 2016). In the current research programme, two biopolymers, namely guar gum and xanthan gum, were chosen as stabilisers due to their availability and good stability properties with respect to temperature and pH variations (Mudgil et al., 2011). In order to evaluate the potential of these biopolymers as stabilisers, a research programme was formulated. From this research programme, an understanding of biopolymer stabilisation has been established, mechanical and hydraulic properties of biopolymer stabilised soils derived and assessment of biopolymer stabilised earthen construction materials undertaken. The major findings of this research programme are highlighted below.

### 6.2 Research highlights

#### 6.2.1 Biopolymer stabilisation

The initial step of the research programme was to understand the potential of using biopolymers as an alternative stabiliser for earthen construction materials. To achieve this, an exploratory campaign to understand the effect of biopolymers on plasticity, shrinkage and strength of earthen construction material was undertaken. It was observed that, the intrinsic chemical characteristics of both biopolymers had significant influence on the observed plasticity and shrinkage characteristics of the stabilised soil. Guar gum increased both liquid limit and linear shrinkage with biopolymer content, while, with xanthan gum after an initial increase at lower

biopolymer content (0.5% by dry soil mass), both liquid limit and linear shrinkage reduced with higher biopolymer content.

In the strength tests campaign, unconfined compression and tensile strengths of biopolymer stabilised earthen material were compared with unamended and cement stabilised earthen construction materials. As noted in Jaquin et al., (2009), a significant component of the strength of unstabilised earthen construction materials can be linked to the suction present due to water content and fine soil fractions. Hence, after the completion of each strength test, total suction and water content were determined. Based on the test results it was noted that, unlike cement, in which stabilisation is achieved through formation of cementitious products, the stabilisation for biopolymer stabilised soils is achieved through combination of soil suction and hydrogel formation. The nature in which these hydrogels interact with the soil particles is dependent on the intrinsic characteristics of the biopolymer. As a neutrally charged polysaccharide, guar gum essentially interacts with soil and water through hydrogen bonding, while xanthan gum, which is an anionic polysaccharide, interacts through hydrogen and ionic bonding (Chudzikowski, 1971; Chen et al., 2013; Chang et al., 2015). The nature of hydrogel interaction with soil particles has due influence on mechanical behaviour especially the tensile strength and stiffness. It was noted that the additional ionic bonding of xanthan gum led to higher tensile strengths of the stabilised earthen material. About 1.5% of biopolymer content of the dry soil mass was sufficient to achieve comparable compressive strength of 8.0% cement stabilised earthen material. However, comparable tensile strength was only achieved by xanthan gum stabilised earthen material at 2.0% of biopolymer content.

### 6.2.2 Geotechnical characterisation

After obtaining an insight on how biopolymer stabilisation influences plasticity, shrinkage and strength characteristics, further investigation was carried out to understand the role of soil suction and hydrogel formation on hydraulic and mechanical properties of biopolymer stabilised soils. In this campaign, to obtain the hydraulic properties, soil-water retention curve for biopolymer stabilised soils was determined, while for the mechanical properties, strength tests in the form of triaxial tests at different curing periods were conducted. Further, to understand the effect of biopolymers on soil structure due to hydrogel formation with aging, X-ray computed tomography scanning for biopolymer stabilised soils at different curing periods were carried out.

#### 6.2.2.1. Suction tests

Results from the suction tests indicate that though guar gum has higher affinity towards water than xanthan gum (Nugent et al., 2009), on drying, water tends to escape rather quickly from guar gum stabilised specimens. This may be due to the fact that the water molecules are loosely held by biopolymer chains through a weak chemical bonding, i.e. hydrogen bonds. In the case of xanthan gum stabilised specimens, the rate of drying was similar to that of unamended soil specimen, indicating that the hydrogel bonding is not so significant to slow the rate of drying during the initial phase of drying.

Soil water retention curves expressed in terms of total suction and gravimetric water content for unamended, guar gum and xanthan gum stabilised soils were determined. In each of these SWRCs, the experimental data was fitted as per the fitting parameters recommended by Fredlund and Xing (1994). For the range of water contents in SWRC, the suction values observed by the biopolymer stabilised soil specimens were higher than unamended soil specimen indicating that hydrogels formed due to biopolymer stabilisation appeared themselves to contribute to soil suction. The effect of biopolymer stabilisation was evident through the increased value of fitting parameter,  $a$ . With the addition of biopolymer, the absorbtive capacity of the soil mix may have increased, which would have increased the air entry value in the SWRC. Between biopolymers, the effect of xanthan gum on  $a$  was higher than that of guar gum. With the changes in fitting parameter,  $n$  it was noted that for the biopolymer stabilised specimens there might be variation in their void size distribution.

The changes in suction and gravimetric water content in residual zone were plotted as scanning curves for all combinations. For unamended specimens, the scanning behaviour matched with the typical description of scanning curves usually observed in unsaturated soils. In the case of biopolymer stabilised soils, the behaviour of both guar and xanthan gum stabilised specimens were atypical to that of unamended soil. It was observed that for a given water content, three or more different suctions were noted. These random variations of total suction and water content are assumed to be associated with the evolution of hydrogels.

### 6.2.2.2. Triaxial tests

The results from constant water triaxial tests suggest that the mechanical behaviour of biopolymer stabilised soils is related to the evolution of the hydrogel state. Both guar and xanthan gum stabilised soils showed ductile behaviour during early curing periods. With aging, the specimens showed appreciable increase in stiffness and peak strength while the specimen had brittle behaviour. Compared to unamended specimens, biopolymer stabilised specimens showed higher peak strength and stiffness at all curing periods. The shear strength parameters for unamended and biopolymer stabilised specimens were obtained from  $p - q$  diagram (Wood, 1990). For guar gum stabilised soil specimens, the variation in shear strength parameters can be primarily associated with the physical state of hydrogels. With the transformation of hydrogels from rubbery to glassy state, cohesion of guar gum stabilised soil reduced, while angle of internal friction increased. Unlike guar gum, xanthan gum stabilised soil specimen retained its cohesion, while the angle of internal friction decreased with time. The variation of shear strength parameters for xanthan gum stabilised soil was dependent on both, the transformation of hydrogels and how the hydrogels interact with soil particles. Xanthan gum stabilised soils form large soil agglomerations caused due to ionic bonding and these agglomerations are linked through chains of hydrogels. With aging, these soil agglomerations remain stable on compression, however, adjacent soil agglomerations slide across each other breaking the network of hydrogels. Hence, with aging, the angle of internal friction seems to reduce slightly, while cohesion of the material is still retained.

### 6.2.2.3. Macrostructure analysis

In order to understand the effect of biopolymers on pore structure, x-ray computed tomography scans were obtained for unamended, guar and xanthan gum stabilised specimens at different curing periods namely 1, 7 and 28 days. The resolution of the scan was maintained at  $8.5 \mu\text{m}$  based on the preliminary study as noted in Chapter 3. Using Avizo software, porosity and void size distribution of all combinations at different curing periods were obtained. On visual inspection of X-RCT scans for unamended and biopolymer stabilised specimens, it was noted that the unamended samples had reduced void space and were more compact. Based on the quantitative analysis, it was noted that the porosity of biopolymer stabilised specimens was higher than unamended specimens. Between biopolymers, xanthan gum stabilised specimens had higher porosity than guar gum stabilised specimens at all curing periods. As a general observation, it was noted that all specimens contained voids in a similar range of  $10^3 - 10^8 \mu\text{m}^3$  connected to an interconnecting void having a volume in the range of  $10^{10} - 10^{11} \mu\text{m}^3$ . Void size distribution suggests both biopolymers have significant and yet different effect on pore structure of the soil mix at macro level. Both biopolymer stabilised specimens showed fewer small pores than unamended specimens indicating soil aggregations caused due to stabilisation. Between biopolymers, xanthan gum stabilised specimens had lesser number of voids in the range of  $10^3 - 10^8 \mu\text{m}^3$ . However, compared to unamended soil specimen, the size of the interconnecting void for biopolymer stabilised specimens was larger.

### 6.2.3 Assessment as building material

As the main aim of the thesis is to understand the potential of the biopolymers as a stabiliser for earthen construction material, it was necessary to explore a range of behaviours as associated with its use as a building material. For this assessment, durability performance, hygroscopic behaviour and recyclability potential of the stabilised material were assessed.

#### 6.2.3.1. Durability tests

Results from contact and suction tests indicate that the compressed earth blocks without any amendment performed satisfactorily against capillary action of water. This is primary due to the nature of clay mineral present in the engineered soil mix used to prepare the brick. Being less susceptible against cracking, artificial kaolin was able to withstand against deterioration under capillary action of water. However, the beneficial effect of biopolymer stabilisation was more evident for adverse durability tests such as erosional resistance and dip tests. In these tests, unamended earthen construction materials failed to satisfy the test requirements, while biopolymer stabilised earthen construction materials performed well. In erosion resistance tests, biopolymer stabilised earthen construction materials with higher percentages of xanthan gum had lesser depths of erosion. Also, the observed rate of erosion was lower for xanthan gum stabilised samples. Between biopolymers, xanthan gum showed a better stabilisation effect to improve durability properties of the stabilised earthen materials. In the case of dip tests, the observed loss of mass for unamended bricks was higher than 15.0%, while for the biopolymer

stabilised bricks the loss of mass was negligible. Based on the classification of DIN 18945 (2013), unamended compressed earth blocks were classified as Class III brick suitable for dry applications, while compressed earth bricks stabilised either through guar gum or xanthan gum were classified as Class Ia brick which are suitable for external wall exposed to natural weathering.

### 6.2.3.2. Hygroscopic behaviour

Moisture buffering values of all combinations of earthen construction materials tested were higher than conventional building materials such as fired brick and concrete. The moisture buffering values for biopolymer stabilised samples were nearly twice to that of conventional building materials. The results from moisture buffering tests were in concurrence with previous literature findings that on addition of cement the hygroscopic properties of earthen construction material are reduced. Addition of biopolymers however have improved the hygroscopic properties of earthen construction materials. The observed moisture buffering values of biopolymer stabilised earthen materials were higher than both unamended and cement stabilised bricks. As per MBV classification by Rode et al., (2005), most of the tested samples can be classified into “moderate” category, while only xanthan gum stabilised brick falls into “good” category. Considering the ability of biopolymers to improve both strength and durability properties without comprising on hygroscopic properties of the stabilised material which is not displayed by cement as a stabiliser makes them promising alternative stabilisers for earthen construction material.

### 6.2.3.3. Recycling potential

Simple washing technique which is typically employed in geotechnical applications was employed to recycle and retrieve original soil properties of guar gum stabilised earthen material. For xanthan gum stabilised earthen material, soil washing technique was not entirely successful to recycle it completely. For xanthan gum, the recycled material resisted washing leading to coarser soil fractions. Based on the chemical tests on water which was used for washing, it was concluded that the water, if disposed immediately may not pose any environmental concerns. Biopolymers may have potential not only in improving the strength and durability of earthen construction material, but also has potential for recycling. This would enable the completion of the life cycle of earthen material without generating construction waste.

## 6.3 Implications of biopolymer stabilisation

### 6.3.1 In geotechnical engineering

Only in the past decade, biopolymers have been introduced in geotechnical applications to improve soil properties. Researchers have explored the possibility of using biopolymers as soil stabilisers, and it has been reported that, when added to soil biopolymers have reduced soil permeability (Bouazza et al., 2009; Aminpour and O’Kelly, 2015), increased shear strength (Cabalar and Canakci, 2011; Chang et al., 2015), improved compressibility (Latifi et al., 2016)

and enhanced durability (Qureshi et al., 2017). Further, biopolymers can stabilise different types of soils with simple application procedure (Chang et al., 2016). Though past literature have reported promising stabilising effects, very few studies have attempted to understand the stabilisation mechanisms of biopolymers (Chang et al., 2015, 2016; Ayeldeen et al., 2016). Further, very few studies have been attempted to understand the soil-water retention properties of biopolymer stabilised soils (Zhao, 2014; Tran et al., 2017).

The research findings from the current study would further the understanding on biopolymer soil stabilisation. While, the Atterberg limits of biopolymer stabilised soils obtained in this study are in agreement with previous studies (Nugent et al., 2009), the linear shrinkage values indicate that xanthan gum provides better volumetric stability than guar gum. The strength tests presented in Chapter 3, suggest that only small quantities of biopolymer (~2.0 % of dry mass of the soil) are required to stabilise earthen construction material to reach comparable compressive strengths of 8.0% cement stabilised soils. Further, the tensile strength test results indicate that the xanthan gum stabilised earthen construction materials can have higher tensile strength than cement stabilised materials. Unlike cement, both biopolymers do not require any special curing conditions for strength gain. In practical applications, large quantities of soil can be stabilised using small quantities of biopolymer without any special curing arrangement. The hydraulic and mechanical properties of biopolymer stabilised soils presented in Chapter 4 suggest that the biopolymer stabilised soils retain more water than unamended soils, but provide better mechanical performance. With better water retentivity and mechanical behaviour, biopolymers can be used in wide range of geotechnical applications where fluctuations of water in the soil affect the performance of the earthen structure, such as earthen slopes, desiccated soils, retaining structures and ground improvement.

### 6.3.2 Application in earthen building construction

Over the last two decades there has been increasing interest in earthen construction materials due to their inherent green credentials. However, use of energy consuming stabilisers like cement to improve the durability of earthen construction materials have raised concerns on their sustainability. Recent research studies suggest that the carbon footprint of modern day stabilised earthen construction material is equivalent to that of weak concrete (Lax, 2010). In this scenario, any stabiliser which can provide necessary stabilisation without comprising on green credentials would be promising alternative to cement and biopolymers may be viable option. As observed from strength tests in Chapter 3, about 1.5 – 2.0% of biopolymer content by mass of the dry soil was sufficient to achieve comparable compressive strength of 8.0% cement stabilised earthen construction material. Further, no special type of curing is needed in manufacturing biopolymer stabilised earthen construction material. In practical scenario, lesser quantity of stabiliser content may be needed to prepare good quality material. With no special curing techniques, less energy may be needed for production of biopolymer stabilised earthen construction materials. If the cost of biopolymers is competitive to that of chemical stabilisers, biopolymers may successfully replace cement as a stabiliser in earthen building construction.

In Chapter 5, biopolymer stabilised compressed earth blocks were tested for durability and hygroscopic performance. Results from different durability tests certainly suggest that biopolymer stabilised earthen construction materials could be competitive earthen building materials. Further, hygroscopic properties of biopolymer stabilised earthen construction materials are better than unamended and cement stabilised materials, indicating, earthen building made out of biopolymer stabilised materials would need less energy for air conditioning. Further, on demolition, biopolymer stabilised earthen construction materials can be recycled without causing any environmental concerns, which ensures no construction waste is generated and completes the life cycle of the earthen construction material. From its production to demolition, biopolymer stabilised earthen construction material may require less energy than cement stabilised materials. Further, biopolymer stabilised materials may have less carbon emissions associated with it. With these credentials, biopolymers as stabilisers may help modern day stabilised earthen construction materials to retain their tag of being sustainable.

### 6.4 Potential future research work

#### 6.4.1 Microstructure analysis

Plasticity and shrinkage characteristics are attributes of the fine fraction of the soil, especially the clay content. Results of Atterberg limits and linear shrinkage values of biopolymer stabilised soils as presented in Chapter 3, certainly indicate that both biopolymers interact with clay portion of the soil which influence plasticity and shrinkage properties. These interactions may have a significant impact on soil structure and the results from macrostructure analysis presented in Chapter 4 certainly suggests there are noticeable variations in void size distribution at macrolevel for biopolymer stabilised soils. Both biopolymers, i.e. guar and xanthan gum stabilised soils showed significant and yet different variation in the void size distribution and porosity. With this background, it is expected that the introduction of biopolymers to soil may have an impact on soil microstructure too. SEM images of biopolymer stabilised mine tailings by Chen et al.,(2013) suggests that biopolymers increase void spaces of the soil. However, there is no published work which quantifies the effect of biopolymers on microstructure in terms of void size distribution or porosity. Any future studies on this aspect would certainly improve understanding of biopolymer-clay interactions.

#### 6.4.2 Durability tests

In the present study, durability properties of biopolymer stabilised earthen construction materials against action of water were evaluated. The various durability tests conducted as prescribed by different international standards are primarily developed to assess unamended or cement stabilised earthen construction materials. Though biopolymer stabilised earthen construction materials have performed satisfactorily against these durability tests, they may be susceptible to other issues. As an example, biopolymers are organic compounds, which are basically food for microbes and under a microbial attack the hydrogels may deteriorate

hindering the performance of biopolymer stabilised earthen material. In this scenario, resistance of the material against microbial attack needs to be evaluated. Thus, future studies should recognise potential threats to durability for biopolymer stabilised earthen construction materials which are not commonly described in any international standards, and assess their resistance against it.

### 6.4.3 Life cycle assessment for biopolymer stabilised earthen materials

The ability of unstabilised earthen construction material to be recycled, completes the life cycle of the material and this ability makes them sustainable. However, cement stabilised earthen construction materials are usually downcycled rather than being recycled (Schroeder, 2016). Recyclability tests as presented in Chapter 5 suggests that biopolymer stabilised earthen construction materials can be recycled, while water used for recycling can be disposed of safely without any environmental concerns. Any future studies which can assess the entire life cycle of biopolymer stabilised earthen construction materials would certify the green credentials of these innovative materials.

### 6.4.4 Field Implementation

Based on the experience gained through the experimental programme, an informal empirical investigation was undertaken in India to understand the implications of using biopolymers as a stabiliser in constructing a rammed earth wall. In an earthen building construction site, using walling construction equipment, four rammed earth wallets of 200 mm thick and 1.0 m height were constructed. The soil used to make the rammed earth wallets conformed to the requirement of standard recommendations. One rammed earth wallet was unstabilised, while other three wallets were cement, guar gum and xanthan gum stabilised wallets. Figure 6.1a presents the freshly constructed rammed earth wallets for all combinations. During the entire process of construction, from mixing of the soil, compaction of layers in the wall and to the removal of shuttering, the problems encountered for constructing biopolymer stabilised rammed earth wallets were noted. It was observed that unlike cement stabilised soil, biopolymer stabilised soil mixes form soil agglomerations very quickly and these pose problems while compacting the soil in layers. After the construction of wall, it was noted that there were cracks between compacted layers of the wallet (Figure 6.1b). The width and length of the cracks increased with aging. However, individual compacted layers for biopolymer stabilised wallets remained intact and hard similar to that of cement stabilised wallets. After 28 days, the interior part of the biopolymer stabilised wallets remained moist, while the outer part of it was dry (Figure 6.1c).

Though this particular exercise was purely empirical, the observations made during this investigation certainly suggest there are many field associated problems which would pose issues for using biopolymers as stabilisers. Apart from laboratory testing, future studies should also focus on full scale models and field trials which would bring out the shortcomings of using biopolymers. These studies would also develop suitable guidelines for using biopolymers in actual construction.

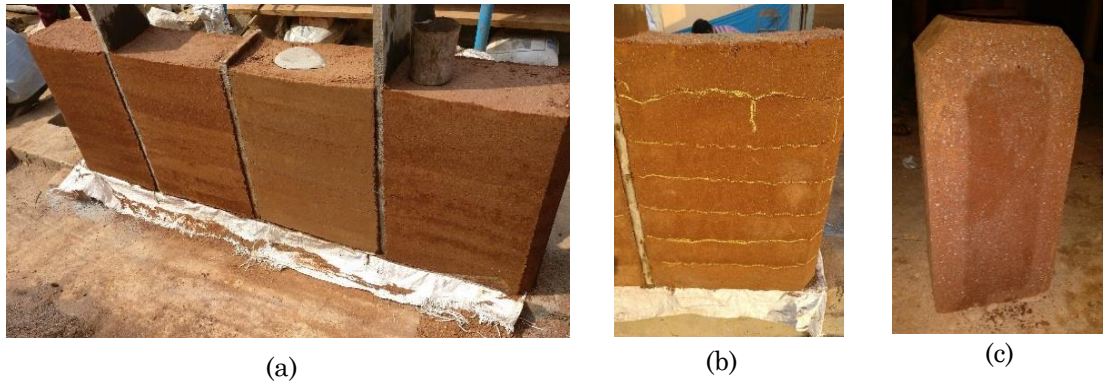

Figure 6.1 Field implementation, (a) constructed rammed earth wallets, (b) cracks and (c) water retention in rammed earth wallet

## 6.5 Concluding remarks

Based on the results obtained from the wide range of tests, it may be concluded that both biopolymers, i.e. guar and xanthan gum have potential to be alternative stabilisers to high energy consuming stabilisers which provide desirable strength and durability to earthen construction materials. It is hoped that this thesis inspires in development of biopolymer stabilised earthen construction materials in future which are both sustainable and durable.

### References

- Aminpour M, and O’Kelly BC. 2015. Applications of biopolymers in dam construction and operation activities. In D. I. and S. R. Pina C., Portela E., Caldeira L., Batista A. (Ed.), Proceedings of the Second International Dam World Conference (DW2015) (pp. 937–946). Lisbon, Portugal: LNEC.
- Ayeldeen MK, Negm AM, and El Sawwaf MA. 2016. Evaluating the physical characteristics of biopolymer/soil mixtures. *Arabian Journal of Geosciences*, 9(5), 329–339.
- Bouazza A, Gates WP, and Ranjith PG. 2009. Hydraulic conductivity of biopolymer-treated silty sand. *Géotechnique*, 59(1), 71–72.
- Cabalar AF, and Canakci H. 2011. Direct shear tests on sand treated with xanthan gum. *Proceedings of the ICE - Ground Improvement*, 164, 57–64.
- Chang I, Im J, and Cho G. 2016a. Geotechnical engineering behaviors of gellan gum biopolymer treated sand. *Canadian Geotechnical Journal*, 53(10), 1658–1670.
- Chang I, Im J, and Cho G-C. 2016b. Introduction of Microbial Biopolymers in Soil Treatment for Future Environmentally-Friendly and Sustainable Geotechnical Engineering. *Sustainability*, 8(3), 251.
- Chang I, Im J, Prasadhi AK, and Cho G-C. 2015. Effects of Xanthan gum biopolymer on soil strengthening. *Construction and Building Materials*, 74(10), 65–72.
- Chen R, Zhang L, and Budhu M. 2013. Biopolymer Stabilization of Mine Tailings. *Journal of Geotechnical and Geoenvironmental Engineering*, 139(10), 1802–1807.
- Chudzikowski RJ. 1971. Guar gum and its applications. *Journal of the Society of Cosmetic Chemists*, 22(1), 43–60.
- DIN18945. 2013. Earth blocks - Terms and definitions, requirements, test methods.
- Fredlund D., and Xing A. 1994. Equations for the soil-water characteristic curve. *Canadian Geotechnical Journal*, 31(4), 521–532.
- Jaquin PA, Augarde CE, Gallipoli D, and Toll DG. 2009. The strength of unstabilised rammed earth materials. *Géotechnique*, 59(5), 487–490.
- Latifi N, Horpibulsuk S, Meehan CL, Majid MZA, and Rashid ASA. 2016. Xanthan gum biopolymer: an eco-friendly additive for stabilization of tropical organic peat. *Environmental Earth Sciences*, 75(9).
- Lax C. 2010. Life cycle assessment of rammed earth. University of Bath. Retrieved from [http://www.ebuk.uk.com/docs/Dissertation\\_Clar e\\_Lax.pdf](http://www.ebuk.uk.com/docs/Dissertation_Clar e_Lax.pdf)
- Mudgil D, Barak S, and Khatkar BS. 2011. Guar gum: processing, properties and food applications—A Review. *Journal of Food Science and Technology*, 51(6), 409–418.
- Nugent RA, Zhang G, and Gambrell RP. 2009. Effect of Exopolymers on the Liquid Limit of Clays and Its Engineering Implications. *Transportation Research Record: Journal of the Transportation Research Board*, 2101(1), 34–43.
- Qureshi MU, Chang I, and Al-Sadarani K. 2017. Strength and durability characteristics of biopolymer-treated desert sand. *Geomechanics and Engineering*, 12(5), 785–801.
- Rode C, Peuhkuri R, Mortensen LH, Hansens K, Time B, Gustavsen A, ... Harderup LE. 2005. Moisture Buffering of Building Materials, Report BYG•DTU R-126, ISSN 1601-2917. ISBN 87-7877-195.
- Schroeder H. 2016. Sustainable Building with Earth. *Sustainable Building with Earth*. Cham: Springer International Publishing.
- Tran TPA, Im J, Cho G-C, and Ilhan Chang. 2017. Soil – water characteristics of xanthan gum biopolymer containing soils. In Proceedings of the 19th International Conference on Soil Mechanics and Geotechnical Engineering, Seoul.
- Wood DM. 1990. Soil behaviour and critical state soil mechanics. Cambridge university press.
- Zhao X. 2014. Measurements and transient multistep outflow simulation of soil-water characteristic curve for soils modified with biopolymers.

# Appendix

In Appendix, the test results of various experimental investigations conducted in the thesis are presented in full. The results shall be read in conjunction with the various discussions undertaken in different chapters of the thesis.

## Chapter 3

### Unconfined compression test results

Table 1. Compression strength data in kPa for guar gum stabilised specimens (For Figure 3.10)

| Biopolymer concentration (%) | 0.5  |      | 1.0  |      | 1.5  |      | 2.0  |      | 3.0  |      |
|------------------------------|------|------|------|------|------|------|------|------|------|------|
|                              | 7    | 28   | 7    | 28   | 7    | 28   | 7    | 28   | 7    | 28   |
| Sample 1                     | 1262 | 1762 | 1874 | 2018 | 2455 | 3563 | 3444 | 3887 | 3759 | 4407 |
| Sample 2                     | 1096 | 1676 | 1966 | 2136 | 2204 | 3166 | 3890 | 4156 | 4209 | 4188 |
| Sample 3                     | 935  | 1580 | 1576 | 1841 | 2475 | 3415 | 3990 | 3949 | 4209 | 4403 |
| Mean                         | 1097 | 1673 | 1805 | 1998 | 2378 | 3381 | 3775 | 3997 | 4059 | 4333 |
| Standard deviation           | 164  | 91   | 204  | 148  | 151  | 201  | 291  | 141  | 260  | 125  |
| Co-efficient of variation    | 0.15 | 0.05 | 0.11 | 0.07 | 0.06 | 0.06 | 0.08 | 0.04 | 0.06 | 0.03 |

Table 2. Soil modulus data in MPa for guar gum stabilised specimens (For Figure 3.11)

| Biopolymer concentration (%) | 0.5  |      | 1.0  |      | 1.5  |      | 2.0  |      | 3.0  |      |
|------------------------------|------|------|------|------|------|------|------|------|------|------|
|                              | 7    | 28   | 7    | 28   | 7    | 28   | 7    | 28   | 7    | 28   |
| Sample 1                     | 127  | 267  | 132  | 245  | 156  | 312  | 156  | 326  | 213  | 303  |
| Sample 2                     | 130  | 211  | 130  | 218  | 104  | 321  | 166  | 348  | 166  | 268  |
| Sample 3                     | 125  | 221  | 137  | 246  | 122  | 379  | 184  | 261  | 177  | 282  |
| Mean                         | 127  | 233  | 133  | 236  | 127  | 337  | 169  | 312  | 185  | 284  |
| Standard deviation           | 2.5  | 29.9 | 3.6  | 15.9 | 26   | 36.4 | 14.2 | 45.2 | 24.6 | 17.6 |
| Co-efficient of variation    | 0.02 | 0.13 | 0.03 | 0.07 | 0.21 | 0.11 | 0.08 | 0.15 | 0.13 | 0.06 |

Table 3. Compression strength data in kPa for xanthan gum stabilised specimens (For Figure 3.10)

| Biopolymer concentration (%) | 0.5  |      | 1.0  |      | 1.5  |      | 2.0  |      | 3.0  |      |
|------------------------------|------|------|------|------|------|------|------|------|------|------|
|                              | 7    | 28   | 7    | 28   | 7    | 28   | 7    | 28   | 7    | 28   |
| Sample 1                     | 1504 | 2386 | 2351 | 2648 | 2789 | 2893 | 4091 | 2805 | 4460 | 3313 |
| Sample 2                     | 1828 | 1789 | 2520 | 1939 | 2916 | 2812 | 4027 | 3696 | 5220 | 4239 |
| Sample 3                     | 1347 | 2024 | 3201 | 2367 | 3160 | 3202 | 4022 | 4166 | 4525 | 4455 |
| Mean                         | 1560 | 2066 | 2691 | 2318 | 2955 | 2969 | 4047 | 3556 | 4735 | 4002 |
| Standard deviation           | 245  | 301  | 450  | 357  | 188  | 206  | 38   | 691  | 421  | 607  |
| Co-efficient of variation    | 0.16 | 0.15 | 0.17 | 0.15 | 0.06 | 0.07 | 0.01 | 0.19 | 0.09 | 0.15 |

Table 4. Soil modulus data in MPa for xanthan gum stabilised specimens (For Figure 3.11)

| Biopolymer concentration (%) | 0.5  |      | 1.0  |      | 1.5  |      | 2.0  |      | 3.0  |      |
|------------------------------|------|------|------|------|------|------|------|------|------|------|
|                              | 7    | 28   | 7    | 28   | 7    | 28   | 7    | 28   | 7    | 28   |
| Sample 1                     | 147  | 270  | 157  | 353  | 195  | 363  | 221  | 300  | 280  | 275  |
| Sample 2                     | 160  | 329  | 189  | 260  | 195  | 393  | 203  | 461  | 305  | 277  |
| Sample 3                     | 189  | 389  | 183  | 372  | 194  | 450  | 195  | 272  | 286  | 382  |
| Mean                         | 165  | 329  | 176  | 328  | 195  | 402  | 206  | 344  | 290  | 311  |
| Standard deviation           | 22   | 60   | 17   | 60   | 1    | 44   | 13   | 102  | 13   | 61   |
| Co-efficient of variation    | 0.13 | 0.18 | 0.10 | 0.18 | 0.01 | 0.11 | 0.06 | 0.30 | 0.04 | 0.20 |

Table 5. Compressive strength in kPa for unamended and cement stabilised samples. (For Figures 3.10 and 3.11)

| Sample                    | Unamended | Cement – 7d | Cement -28d |
|---------------------------|-----------|-------------|-------------|
| Sample 1                  | 326       | 2253        | 2453        |
| Sample 2                  | 446       | 3289        | 3689        |
| Sample 3                  | 336       | 2786        | 2956        |
| Mean                      | 369       | 2776        | 3033        |
| Standard deviation        | 67        | 518         | 622         |
| Co-efficient of variation | 0.18      | 0.19        | 0.20        |

Table 6. Soil Modulus in MPa for unamended and cement stabilised samples (For Figures 3.10 and 3.11)

| Sample                    | Unamended | Cement – 7d | Cement -28d |
|---------------------------|-----------|-------------|-------------|
| Sample 1                  | 25        | 190         | 235         |
| Sample 2                  | 46        | 230         | 265         |
| Sample 3                  | 26        | 240         | 255         |
| Mean                      | 32        | 220         | 252         |
| Standard deviation        | 12        | 26          | 15          |
| Co-efficient of variation | 0.37      | 0.12        | 0.06        |

Tensile Strength test results

Table 7. Tensile strength data in kPa for guar gum stabilised specimens (For Figure 3.15)

| Biopolymer concentration (%) | 1.5  |      | 2.0  |      | 2.5  |      | 3.0  |      |
|------------------------------|------|------|------|------|------|------|------|------|
| Curing period (day)          | 7    | 28   | 7    | 28   | 7    | 28   | 7    | 28   |
| Sample 1                     | 65   | 44   | 160  | 97   | 94   | 79   | 138  | 57   |
| Sample 2                     | 49   | 30   | 157  | 150  | 177  | 50   | 239  | 67   |
| Sample 3                     | 30   | 110  | 150  | 91   | 164  | 220  | 188  | 226  |
| Mean                         | 48   | 61   | 156  | 113  | 145  | 116  | 188  | 117  |
| Standard deviation           | 17   | 43   | 5    | 32   | 45   | 91   | 51   | 95   |
| Co-efficient of variation    | 0.36 | 0.70 | 0.03 | 0.29 | 0.31 | 0.78 | 0.27 | 0.81 |

Table 8. Tensile strength data in kPa for xanthan gum stabilised specimens (For Figure 3.15)

| Biopolymer concentration (%) | 1.5  |      | 2.0  |      | 2.5  |      | 3.0  |      |
|------------------------------|------|------|------|------|------|------|------|------|
| Curing period (day)          | 7    | 28   | 7    | 28   | 7    | 28   | 7    | 28   |
| Sample 1                     | 81   | 178  | 131  | 157  | 140  | 251  | 168  | 79   |
| Sample 2                     | 92   | 168  | 171  | 287  | 152  | 193  | 124  | 411  |
| Sample 3                     | 82   | 158  | 76   | 402  | 201  | 535  | 189  | 354  |
| Mean                         | 85   | 168  | 126  | 282  | 164  | 326  | 160  | 281  |
| Standard deviation           | 6    | 10   | 48   | 123  | 32   | 183  | 33   | 178  |
| Co-efficient of variation    | 0.07 | 0.06 | 0.38 | 0.43 | 0.20 | 0.56 | 0.21 | 0.63 |

Table 9. Tensile strength in kPa for unamended and cement stabilised samples. (For Figure 3.15)

| Sample                    | Unamended | Cement – 7d | Cement -28d |
|---------------------------|-----------|-------------|-------------|
| Sample 1                  | 33        | 220         | 235         |
| Sample 2                  | 29        | 200         | 218         |
| Sample 3                  | 33        | 198         | 228         |
| Mean                      | 32        | 206         | 227         |
| Standard deviation        | 2         | 12          | 9           |
| Co-efficient of variation | 0.07      | 0.06        | 0.04        |

Synergistic behaviour of biopolymers

Table 10. Compression strength data in kPa for synergistic combinations (For Figure 3.18)

| Combination               | 1    |      | 2    |      | 3    |      |
|---------------------------|------|------|------|------|------|------|
|                           | 7d   | 28d  | 7d   | 28d  | 7d   | 28d  |
| Sample 1                  | 3071 | 4782 | 4319 | 4244 | 3664 | 4150 |
| Sample 2                  | 3771 | 4416 | 3927 | 3928 | 3669 | 4323 |
| Sample 3                  | 3867 | 3780 | 4019 | 3374 | 3926 | 4351 |
| Mean                      | 3570 | 4326 | 4088 | 3849 | 3753 | 4275 |
| Standard deviation        | 435  | 507  | 205  | 440  | 150  | 109  |
| Co-efficient of variation | 0.12 | 0.12 | 0.05 | 0.11 | 0.04 | 0.03 |

Table 11. Soil modulus data in MPa for synergistic combinations (For Figure 3.18)

| Combination               | 1    |      | 2    |      | 3    |      |
|---------------------------|------|------|------|------|------|------|
|                           | 7d   | 28d  | 7d   | 28d  | 7d   | 28d  |
| Sample 1                  | 166  | 270  | 368  | 380  | 254  | 290  |
| Sample 2                  | 263  | 276  | 248  | 264  | 314  | 294  |
| Sample 3                  | 260  | 259  | 344  | 285  | 332  | 315  |
| Mean                      | 230  | 268  | 320  | 310  | 300  | 300  |
| Standard deviation        | 55   | 9    | 63   | 62   | 41   | 13   |
| Co-efficient of variation | 0.24 | 0.03 | 0.20 | 0.20 | 0.14 | 0.04 |

Table 12. Tensile strength data in kPa for synergistic combinations (For Figure 3.15)

| Combination               | 1    |      | 2    |      | 3    |      |
|---------------------------|------|------|------|------|------|------|
|                           | 7d   | 28d  | 7d   | 28d  | 7d   | 28d  |
| Sample 1                  | 87   | 209  | 148  | 234  | 190  | 261  |
| Sample 2                  | 171  | 215  | 171  | 270  | 171  | 236  |
| Sample 3                  | 145  | 185  | 145  | 230  | 206  | 283  |
| Mean                      | 134  | 200  | 155  | 245  | 189  | 261  |
| Standard deviation        | 43   | 16   | 14   | 23   | 18   | 24   |
| Co-efficient of variation | 0.32 | 0.08 | 0.09 | 0.09 | 0.09 | 0.09 |

## Chapter 4

### Constant water content triaxial test results (For Table 4.1)

Table 13. Soil Modulus from triaxial tests in MPa for unamended samples

| Curing period (days)      | 1    | 4    | 7    | 10   | 14   | 28   |
|---------------------------|------|------|------|------|------|------|
| Sample 1                  | 82   | 88   | 96   | 126  | 102  | 126  |
| Sample 2                  | 93   | 95   | 92   | 121  | 116  | 132  |
| Sample 3                  | 116  | 118  | 128  | 128  | 140  | 138  |
| Mean                      | 97   | 100  | 105  | 125  | 119  | 132  |
| Standard deviation        | 18   | 16   | 20   | 4    | 19   | 6    |
| Co-efficient of variation | 0.18 | 0.16 | 0.19 | 0.03 | 0.16 | 0.05 |

Table 14. Soil Modulus from triaxial tests in MPa for guar gum stabilised samples

| Curing period (days)      | 1    | 4    | 7    | 10   | 14   | 28   |
|---------------------------|------|------|------|------|------|------|
| Sample 1                  | 76   | 172  | 268  | 274  | 269  | 242  |
| Sample 2                  | 86   | 177  | 264  | 237  | 241  | 238  |
| Sample 3                  | 100  | 150  | 252  | 288  | 270  | 285  |
| Mean                      | 87   | 166  | 261  | 266  | 260  | 255  |
| Standard deviation        | 12   | 14   | 8    | 26   | 16   | 26   |
| Co-efficient of variation | 0.14 | 0.09 | 0.03 | 0.10 | 0.06 | 0.10 |

Table 15. Soil Modulus from triaxial tests in MPa for xanthan gum stabilised samples

| Curing period (days)      | 1    | 4    | 7    | 10   | 14   | 28   |
|---------------------------|------|------|------|------|------|------|
| Sample 1                  | 69   | 190  | 264  | 287  | 239  | 258  |
| Sample 2                  | 68   | 170  | 286  | 289  | 273  | 260  |
| Sample 3                  | 87   | 198  | 276  | 292  | 282  | 262  |
| Mean                      | 75   | 186  | 275  | 289  | 265  | 260  |
| Standard deviation        | 11   | 14   | 11   | 3    | 23   | 2    |
| Co-efficient of variation | 0.14 | 0.08 | 0.04 | 0.01 | 0.09 | 0.01 |

## Chapter 5

### Geelong erosion test results (For Figure 5.7)

Table 16. Depth of erosion in mm for tile specimens after 7 days of curing

| Sample                    | Unamended | Cement | Guar gum | Xanthan gum | 1.5%GG + 0.5%XG | 1.0%GG + 1.0%XG | 0.5%GG + 1.5%XG |
|---------------------------|-----------|--------|----------|-------------|-----------------|-----------------|-----------------|
| Sample 1                  | 8.6       | 0.12   | 2.47     | 2.06        | 2.95            | 2.27            | 1.85            |
| Sample 2                  | 8.7       | 0.1    | 2.36     | 2.46        | 2.76            | 2.27            | 2.08            |
| Sample 3                  | 7.6       | 0.15   | 3.14     | 1.61        | 2.54            | 3.87            | 1.43            |
| Sample 4                  | 7.7       | 0.1    | 2.28     | 1.31        | 3.22            | 2.98            | 1.98            |
| Sample 5                  | 7.8       | 0.12   | 2.98     | 1.87        | 2.81            | 2.92            | 1.43            |
| Mean                      | 8.1       | 0.12   | 2.65     | 1.86        | 2.86            | 2.86            | 1.75            |
| Standard deviation        | 0.53      | 0.1    | 0.39     | 0.44        | 0.25            | 0.66            | 0.31            |
| Co-efficient of variation | 0.07      | 0.15   | 0.15     | 0.23        | 0.09            | 0.23            | 0.17            |

Table 17. Depth of erosion in mm for tile specimens after 28 days of curing

| Sample                    | Unamended | Cement | Guar gum | Xanthan gum | 1.5%GG + 0.5%XG | 1.0%GG + 1.0%XG | 0.5%GG + 1.5%XG |
|---------------------------|-----------|--------|----------|-------------|-----------------|-----------------|-----------------|
| Sample 1                  | 8.1       | 0.1    | 2.36     | 2.37        | 3.10            | 2.67            | 2.35            |
| Sample 2                  | 8.2       | 0.12   | 2.24     | 2.42        | 2.72            | 2.89            | 3.06            |
| Sample 3                  | 7.1       | 0.14   | 3.05     | 1.57        | 2.48            | 4.20            | 2.50            |
| Sample 4                  | 7.1       | 0.1    | 2.22     | 1.30        | 3.20            | 3.44            | 2.48            |
| Sample 5                  | 7.2       | 0.13   | 2.97     | 1.96        | 2.85            | 3.66            | 2.33            |
| Mean                      | 7.5       | 0.12   | 2.36     | 1.93        | 2.87            | 3.37            | 2.54            |
| Standard deviation        | 0.55      | 0.1    | 2.24     | 0.49        | 0.29            | 0.61            | 0.30            |
| Co-efficient of variation | 0.07      | 0.15   | 3.05     | 0.25        | 0.10            | 0.18            | 0.12            |

Table 18. Depth of erosion in mm for cylindrical specimens after 7 days of curing

| Sample                    | Unamended | Cement | Guar gum | Xanthan gum | 1.5%GG + 0.5%XG | 1.0%GG + 1.0%XG | 0.5%GG + 1.5%XG |
|---------------------------|-----------|--------|----------|-------------|-----------------|-----------------|-----------------|
| Sample 1                  | 9.45      | 0.01   | 1.30     | 1.05        | 1.65            | 0.80            | 1.37            |
| Sample 2                  | 11.20     | 0.01   | 1.61     | 1.38        | 0.97            | 1.88            | 0.72            |
| Sample 3                  | 10.20     | 0.02   | 1.81     | 1.10        | 2.59            | 1.86            | 1.08            |
| Sample 4                  | 10.05     | 0.01   | 1.90     | 1.51        | 0.98            | 0.82            | 1.32            |
| Sample 5                  | 9.55      | 0.01   | 0.93     | 1.22        | 1.15            | 1.11            | 1.19            |
| Mean                      | 10        | 0.01   | 1.51     | 1.25        | 1.47            | 1.29            | 1.14            |
| Standard deviation        | 0.70      | 0.00   | 0.40     | 0.19        | 0.69            | 0.54            | 0.26            |
| Co-efficient of variation | 0.07      | 0.17   | 0.26     | 0.15        | 0.47            | 0.42            | 0.23            |

Table 19. Depth of erosion in mm for cylindrical specimens after 28 days of curing

| Sample                    | Unamended | Cement | Guar gum | Xanthan gum | 1.5%GG + 0.5%XG | 1.0%GG + 1.0%XG | 0.5%GG + 1.5%XG |
|---------------------------|-----------|--------|----------|-------------|-----------------|-----------------|-----------------|
| Sample 1                  | 8.00      | 0.01   | 2.58     | 1.68        | 2.64            | 1.36            | 1.92            |
| Sample 2                  | 9.05      | 0.01   | 2.82     | 1.73        | 1.93            | 3.75            | 1.44            |
| Sample 3                  | 8.15      | 0.02   | 3.53     | 1.27        | 4.27            | 3.28            | 1.91            |
| Sample 4                  | 8.50      | 0.01   | 3.52     | 1.74        | 1.84            | 1.55            | 1.91            |
| Sample 5                  | 8.65      | 0.01   | 1.83     | 1.40        | 2.14            | 2.18            | 2.10            |
| Mean                      | 8.5       | 0.01   | 2.85     | 1.56        | 2.56            | 2.42            | 1.85            |
| Standard deviation        | 0.42      | 0.00   | 0.71     | 0.21        | 1.00            | 1.06            | 0.25            |
| Co-efficient of variation | 0.05      | 0.17   | 0.25     | 0.14        | 0.39            | 0.44            | 0.13            |

Dip tests (For Figure 5.14)

Table 20. Loss of mass in percentage for bricks

| Sample                    | Unamended | Guar gum | Xanthan gum |
|---------------------------|-----------|----------|-------------|
| Sample 1                  | 18.85     | 0.80     | 0.72        |
| Sample 2                  | 20.50     | 1.15     | 1.05        |
| Sample 3                  | 16.95     | 0.90     | 0.80        |
| Mean                      | 18.77     | 0.95     | 0.86        |
| Standard deviation        | 1.78      | 0.18     | 0.17        |
| Co-efficient of variation | 0.09      | 0.19     | 0.20        |

### Moisture buffering test results

Table 21. Moisture buffering values in g/m<sup>2</sup>%RH for all samples (For Figure 5.22)

| Sample                    | Cylinder Unamended | Cylinder Cement | Cylinder Guar gum | Brick Guar gum | Cylinder Xanthan gum | Brick Xanthan gum |
|---------------------------|--------------------|-----------------|-------------------|----------------|----------------------|-------------------|
| Sample 1                  | 0.735              | 0.540           | 0.939             | 1.011          | 1.035                | 1.142             |
| Sample 2                  | 0.764              | 0.535           | 0.995             | 1.107          | 0.995                | 1.214             |
| Sample 3                  | 0.702              | 0.585           | 1.033             | 0.904          | 1.009                | 1.13              |
| Mean                      | 0.734              | 0.553           | 0.989             | 1.007          | 1.013                | 1.162             |
| Standard deviation        | 0.031              | 0.028           | 0.047             | 0.102          | 0.020                | 0.045             |
| Co-efficient of variation | 0.042              | 0.050           | 0.048             | 0.101          | 0.020                | 0.039             |