

Durham E-Theses

Establishing predictors of learning strategies; an investigation of the development of, and evolutionary foundations of, intrinsic and extrinsic factors influencing when we learn from others and from whom we learn

BRUCE RAWLINGS

How to cite:

RAWLINGS, BRUCE (2018) Establishing predictors of learning strategies; an investigation of the development of, and evolutionary foundations of, intrinsic and extrinsic factors influencing when we learn from others and from whom we learn. Doctoral thesis, Durham University.

Use policy

The full-text may be used and/or reproduced, and given to third parties in any format or medium, without prior permission or charge, for personal research or study, educational, or not-for-profit purposes provided that:

- a full bibliographic reference is made to the original source
- a <https://etheses.durham.ac.uk/id/eprint/12800/> is made to the metadata record in Durham E-Theses
- the full-text is not changed in any way

The full-text must not be sold in any format or medium without the formal permission of the copyright holders.

Please consult the [full Durham E-Theses policy](#) for further details.

Establishing predictors of learning strategies; an investigation of the development of, and evolutionary foundations of, intrinsic and extrinsic factors influencing when we learn from others and from whom we learn

Bruce S. Rawlings (BSc, MSc)

A thesis presented for the degree of Doctor of Philosophy

Department of Anthropology

Durham University

April 2018

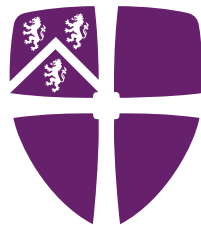

Durham
University

Table of Contents

List of Tables.....	16
Declaration.....	18
Statement of Copyright	19
Acknowledgments.....	20
Thesis Abstract	24
Chapter 1: General Introduction	26
1.1 Introduction	26
1.2 Learning strategies	27
1.3 Approaches to studying learning strategies.....	29
1.4 Aim and Structure of this Thesis	32
Chapter 2 Literature Review: Individual differences in children’s and chimpanzee’s use of social and asocial information: The role of personality and social network positions	34
2.1 Introduction	35
2.2 Social learning and social information use.....	37
2.2.1 Children’s social learning and social information use	37
2.2.2 Chimpanzee social learning and social information use	39
2.3 Asocial learning and innovation	42
2.3.1 Children’s asocial learning and innovation	44
2.3.2 Chimpanzee asocial learning and innovation	46
2.4 The role of context	48

2.5 Are there individual differences in human and animal learning strategies?	50
2.5.1 Individual differences in social information use and social learning.....	51
2.5.2 Individual differences in asocial learning and innovation.....	53
2.6 Personality and Social Networks	55
2.6.1 Personality	56
2.6.2 Human personality social information use and social learning	57
2.6.3 Animal personality, social information use and social learning.....	59
2.7 Personality, asocial learning and innovation	61
2.7.1 Human personality asocial learning and innovation	61
2.7.2 Animal personality, asocial learning and innovation	63
2.8 Social network positions	65
2.8.1 Social learning, social information use and social network positions.....	67
2.8.2 Asocial learning, innovation and social network positions	69
2.9 Conclusion.....	70
Chapter 3: General Methods.....	74
3.1 The comparative approach	75
3.2 Participants and subjects	77
3.2.1 Children	77
3.2.2 Chimpanzees	79
3.3 Puzzle-boxes	80
3.3.1 Children	82

3.3.2 Chimpanzees	83
3.3 Personality	84
3.3.1 Children	85
3.3.2 Chimpanzees	85
3.4 Children’s social network data	86
3.5 Testing procedures	86
3.5.1 Children	86
3.5.2 Chimpanzees	87
3.6 Ethical approval and consent	88
3.6.1 Children	88
3.6.2 Chimpanzees	89
3.7 Statistical Analysis.....	90
3.8 Conclusion	92

Chapter 4: The role of personality on children’s copying and innovation propensities:

Conscientiousness, agreeableness and openness matter.....93

Abstract	93
4.1 Introduction	95
4.2 Methods	101
4.2.1 Participants.....	101
4.2.2 Battery of Tasks	101
4.2.2.1 Personality Instrument.....	101

4.2.3 Experimental Tasks	102
4.2.3.1 Multi-Methods Box	102
4.2.3.2 MMB Coding	105
4.2.3.3 The Alternate Uses Test.....	107
4.2.3.4 The Hook Task	107
4.2.4 Statistical analyses.....	109
4.2.5 Reliability of parent-teacher personality ratings.....	111
4.3 Results	111
4.3.1 MMB	111
4.3.1.1 All participants	111
4.3.1.2 Assessing the first attempt	112
4.3.1.3 All participants' behaviours on the MMB combined (all 10 attempts).....	113
4.3.1.4 Assessing children who elected for demonstrations and for no demonstrations separately (all 10 attempts)	117
4.3.3 The Hook Task.....	118
4.3.3.1 Overall performance and personality.....	118
4.3.3.2 Comparing those who elected for demonstrations with the MMB versus those who did not.....	120
4.3.4 Alternate Uses task.....	121
4.3.4.1 Overall performance	121

4.3.4.2 Comparing children who elected for demonstrations with the MMB with those who did not.....	122
4.4 Discussion.....	123
4.4.1 The role of personality: Agreeableness, conscientiousness and openness matter	124
4.4.2 Age and sex differences.....	127
4.4.3 Cross-task consistency: The relationship between puzzle-box learning strategy choice and performance on innovation and creativity tasks	129
4.5 Conclusions and Implications.....	130

Chapter 5: Innovators have many friends: Investigating the relationship between children’s social network properties and the propensity to copy or innovate. 132

Abstract	132
5.1 Introduction	134
5.2 Methods	141
5.2.1 Participants.....	141
5.2.2 Social Networks	142
5.2.3 Tasks.....	143
5.2.3 Statistical analysis	144
5.2.4 Social network analysis	144
5.3 Results	146
5.3.1. Multi-methods box	146
5.3.1.2 All participants	146

5.3.1.2 Assessing the first attempt	146
5.3.1.3 Examining all participants' behaviours on the MMB combined over 10 attempts.....	147
5.3.1.4 Assessing those who witnessed a demonstration and those who did not separately (all 10 attempts).....	148
5.3.2 The relationship between social network measures and performance on the Hook Task and Alternate Uses task: all participants.....	150
5.4 Discussion.....	152
5.5 Conclusions and implications.....	157
Chapter 6 Assessing the stability of chimpanzee personality: A longitudinal approach ...	159
Abstract	160
6.1 Introduction	161
6.2 Methods.....	167
6.2.1 Subjects.....	167
6.2.2 Materials and Procedure	168
6.2.2.1 Personality Instrument.....	168
6.2.2.2 Personality Ratings.....	169
6.2.3 Statistical analysis	169
6.3 Results	171
6.3.1 Reliability of ratings.....	171
6.3.2 Mean-level consistency	172
6.3.2.1 Main effects over time.....	172

6.3.3 Sex differences.....	173
6.3.4 Rank-order stability.....	175
6.4 Discussion.....	176

Chapter 7: Individual differences in chimpanzee learning strategy behaviour: Assessing the role of personality..... 183

Abstract.....	183
7.1 Introduction.....	185
7.2 Experiment 1: Method.....	191
7.2.1 Subjects.....	191
7.2.2 Materials.....	191
7.2.2.1 Personality Instrument.....	191
7.2.2.2 Personality Ratings.....	193
7.2.2.3 Puzzle-box.....	193
7.2.2.4 Video Demonstrations.....	194
7.2.3 Procedure.....	195
7.2.4 Control conditions.....	197
7.2.5 Coding.....	198
7.2.6 Statistical analysis.....	198
7.3 Results.....	199
7.3.1 Observations of video demonstrations (social information).....	199
7.3.1.1 Time spent observing video demonstrations.....	199

7.3.1.2 Experimental vs control groups	200
7.3.2 Experimental groups: Effects of sex, social group and personality on puzzle-box interactions	201
7.3.2.1 Number of observations of conspecifics' task interactions	201
7.3.2.2 Total number of puzzle-box successes overall.....	202
7.3.2.3 Number of successes of video-demonstrated methods (Blue Spotted and Green Chequered doors combined).....	202
7.3.2.4 Number of successes of non-video-demonstrated methods (Red Striped and Black Striped doors combined).....	203
7.4 Discussion.....	203
7.5 Experiment 2: Methods	205
7.5.1 Subjects and personality	205
7.5.2 Materials	206
7.5.2.1 Puzzle-box.....	206
7.5.3 Human demonstrations	207
7.5.4. Procedure	208
7.5.5. Control measures and groups.....	209
7.5.6 Coding	209
7.6 Results	211
7.6.1 Social information use	211
7.6.1.1 Chimpanzees' first interactions.....	211

7.6.1.2 Observing human demonstrations over all testing sessions.....	212
7.6.1.3 Observing conspecifics over all testing sessions.....	212
7.6.1.4 Did human demonstrations influence Chimpbola behaviours?	213
7.6.2 Overall Chimpbola success.....	214
7.6.3 Cross-task consistency: Experiments 1 and 2.....	216
7.7 Discussion.....	217
7.8 General Discussion	218
7.8.1 Use of social or asocial information.....	218
7.8.2 The role of personality.....	220
7.8.3 Cross-task consistency.....	222
7.9 Conclusions and implications	225
Chapter 8: General Discussion.....	227
8.1 Preferences for social or asocial information	228
8.2 Individual differences in learning strategy use.....	230
8.2.1 Personality	230
8.2.2 Social network positions.....	235
8.2.3 Age and sex effects.....	237
8.3 Cross-task performance and the importance of experimental design	242
8.4 Personality and social networks.....	245
8.5 Limitations of the thesis studies.....	247
8.5.1 Differences in experimental setup between child and chimpanzee studies	247

8.5.1.1 Individual versus social testing	247
8.5.1.2 Types of social information and methods of presentation	248
8.5.2 WEIRD children and BIZARRE chimpanzees	250
8.6 Future directions	251
8.6.1 Untangling potential causal or mediating factors, the and direction of, the relationships found	252
8.6.3 Developing the use of multi-action puzzle-boxes	255
8.6.4 Moving beyond WEIRD AND BIZARRE populations	256
8.7 Concluding remarks	257
References	258
Appendices	301
Appendix 3.1: An example of the consent form administered to parents	301
Appendix 4.1: The personality questionnaire administered to parents of participants, as developed by Asendorpf & van Aiken (2003). Wording was corrected for versions administered to teachers.....	303
Appendix 4.2: Chapter 4 full details of regression models	304
4.2.1 All participants' behaviours on the MMB combined	304
4.2.2 Children who elected for social demonstrations	305
4.3 The Hook Task.....	307
4.4 Alternate Uses.....	308
4.4.1 Overall performance.....	308
4.4 Hook task methods: Regression analysis conducted with personality traits added as covariates .	309

Appendix 5.1: Chapter 5 full details of regression models.....	310
5.1.1 All participants’ behaviours on the MMB combined.....	310
5.1.2 Children who elected for a demonstration.....	312
5.1.3 Children who elected for no demonstrations.....	313
5.2 The relationship between social network measures and performance on the Hook Task and Alternate Uses task (all participants)	315
5.2.1 Hook Task.....	315
5.2.2 Alternate Uses Task.....	316
Appendix 6.1 An example of the personality questionnaire administered to carestaff.....	317
Appendix 6.2 ICC (3,k) inter rater reliability values for T1 between April 2006-December 2008 (taken from Freeman et al. 2013) and for T2, between September 2015-December 2016 (collected for this thesis).....	325
Appendix 7.1: Chapter 7 full details of regression models.....	327
7.1.1 Experiment 1: Observations of video demonstrations (social information).....	327
7.2.1.1 Time spent observing video demonstrations.....	327
7.1.2 Experimental groups: Effects of sex, social group and personality on puzzle-box interactions	328
7.1.2.1 Number of observations of conspecifics’ task interactions	328
7.1.2.2 Number of observations of conspecifics solving the task.....	329
7.1.2.3 Total number of puzzle-box solves overall.....	329
7.1.2.4 Number of successes of video-demonstrated methods (Blue Spots and Green Chequered doors).....	329

7.1.2.5 Number of successes of non-video-demonstrated methods (Red Striped and Black Striped doors).....	330
7.2 Experiment 2.....	330
7.2.1 Chimpanzees' first interactions.....	330
7.2.2 Observing human demonstrations over all testing sessions	331
7.2.3 Observing conspecifics over all testing sessions	332
7.2.4 Overall Success	332

List of Figures

Figure 2.1: Adapted from Rendell et al. (2011); the three forms of context dependent social learning biases and their subcomponents.	50
Figure 3.1: Examples of two-action puzzle-boxes, taken from Flynn et al. (2016). The left puzzle-box (slide-door box) requires sliding doors left or right to extract sticker rewards, and the right (panpipes) can be solved by using either a ‘poke’ or ‘lift’ technique using a stick tool.....	81
Figure 3.2: The Multi-Methods Box. A puzzle-box offering multiple ways of extracting sticker rewards contained within capsules (a), and the three tools available (b).....	82
.....	84
Figure 3.3: Chimpbola (A) and Lazy-Alpha (B). Both boxes could be turned 360 degrees in any direction on a vertical (Lazy-Alpha) or horizontal axis (Chimpbola) and both were ‘four-action’ designs.....	84
Figure 3.4: An example of the experimental setup for chimpanzee experiments.	88
Figure 3.5: An example of an acceptable diagnostic plot for multiple regressions. This displays a plot of standardized residuals with standardized predicted values.	91
Figure 4.1: The Multi-Methods Box. A puzzle-box offering multiple ways of extracting sticker rewards contained within capsules (a), and the three tools available (b).....	105
Figure 4.2: The Hook Task apparatus, with the distractor item piece of string (white) and pipe cleaner (black). Figure taken from Cutting, Apperly, Chappell, & Beck (2014).....	109
Figure 4.3: Breakdown of the percentages of MMB matching behaviours the same method as the social demonstration by children who elected for demonstrations. For evaluative purposes, the comparative percentages of children who elected for no demonstrations are provided. *** denotes significance at $p < .001$	113
Figure 4.4: A breakdown of the percentage of children selecting demonstrations and children selecting no demonstrations with the MMB using each technique on the Hook Task.	121

Figure 6.1: Results revealed significant sex by time interactions for agreeableness (A) and openness (B).
.....175

Figure 7.1: The Lazy-Alpha puzzle-box. The box could freely spin around on a 360 axis and had four ‘doors’, each with differing colour-patterns that when opened released a reward (A). The puzzle-box was self-rebaiting, such that after opening, when no pressure was exerted on a door it would automatically close, and when reopened would dispense another reward (B). Each of the four ‘sides’ corresponding to each door could hold approximately 20 tomato rewards.194

Figure 7.2: Example of the experimental setup. Two identical boxes were simultaneously presented to prevent dominant individuals monopolising apparatuses.197
.....206

Figure 7.3: Chimpbola puzzle-boxes: The boxes could be freely rotated on a 360 degrees horizontal axis to access one of four different doors. Each door required a different technique and had different colour-pattern designs (identical across the two versions of the puzzle-box).....206

Figure 7.4: An example of a human demonstration on the social box.208

List of Tables

Table 4.1 Details of all MMB regression analysis conducted (for all participants, children who elected for demonstrations and children who elected for no demonstrations). Bold type reflects significance at $p < .05$. +ve denotes significant positive relationships and -ve denotes significant negative relationships. ¹ For binary logistic regressions, Nagelkerke's R^2 is reported.	116
Table 4.2: Performance on the Hook and Alternate Uses Tasks, broken down by learning strategy choice.	123
Table 5.1: Details of all MMB regression analysis conducted (all participants, children who elected for demonstrations and children who elected for no demonstrations). Bold type reflects significance at $p < .05$. +ve denotes significant positive relationships and -ve denotes significant negative relationships. ¹ for binary logistic regressions, Nagelkerke's R^2 is reported.	151
Table 6.1: The six personality factors with their corresponding facets. (-) denotes negative loadings...	168
Table 6.2: Mean ratings of each of the six factors at T1 (April 2006-December 2008) to T2 (September 2015-December 2016). Bold type reflects significance. * denotes significant at $p < .05$, ** denotes significance at $p < .01$ and *** denotes significance at $p < .001$	173
Table 6.3: Mean ratings of each of the six factors at T1 (April 2006-December 2008) and T2 (September 2015-December 2016), for males and females.....	175
Table 6.4: Rank-order stability correlation coefficients (Spearman's rho), and a breakdown of the individual level changes in ranking positions between T1 and T2, for the six personality factors. *denotes significance at $p < .05$, **denotes significance at $p < .01$ and ***denotes significance at $p < .001$	176
Table 7.1: The six personality factors with their corresponding facets. (-) denotes negative loadings...	192
Table 7.2: Details of all MMB regression analysis conducted for Experiment 1. Bold type reflects significance at $p < .05$. +ve denotes significant positive relationships and -ve denotes significant negative relationships.	203

Table 7.3: Details of all MMB regression analysis conducted for Experiment 2. Bold type reflects significance at $p < .05$. +ve denotes significant positive relationships and -ve denotes significant negative relationships. ¹ For binary logistic regressions, Nagelkerke's R^2 is reported.215

Table 7.4: Assessment of cross-task consistency (Pearson's correlations) in learning strategy behaviours. Bold type reflects significance at $p < .05$216

Declaration

I confirm that no part of the material presented in this thesis has previously been submitted for a degree in this or any other institution. If material has been generated through joint work, this has been indicated where appropriate. All other sources have been referenced, and quotations suitably indicated.

Statement of Copyright

The copyright of this thesis rests with the author. No quotation from it should be published without the author's prior written consent and information derived from it should be acknowledged.

Acknowledgments

Firstly, to Rachel and Emma. It is absolutely no exaggeration whatsoever to say you have been the best supervisors I have ever experienced. It has been a privilege to learn and develop under your knowledge, advice, guidance and skillsets, and I am undoubtedly academically the best I could have been at this stage of my career - and that is entirely down to your tutorship. But more importantly, your support, understanding, empathy, generosity and humour has made my PhD genuinely enjoyable and the envy of my peers. While I will always regard you as unequaled mentors, I also regard you and your families as friends. Your commitment, help and understanding has been particularly important for the securing of my next adventure, but it is with a genuinely heavy heart that I will be leaving Durham and your supervision. I'll always be hopeful of working together in the future, and Hannah and I will always be indebted to you both.

And equally to Hannah. When you got your PhD in Lancaster, I got a job in Portsmouth and moved to Brighton. When I got my PhD in Durham, you not only got a job at the same university, but then moved with me to Austin and got a job there. And then ended up with a postdoc. Your devotion to us has made this PhD easy, and has laid the platform for my career. Your own ability has put you in an amazing position. You always inspire me, and I will continuously be a better person and academic with you as my wife. Your insights have tightened my experimental rigour (but one day you'll just have to accept that anthropologists/primatologists cannot control for everything like you lab-based cognitive psychologists, nor do we want to), and your formatting is flawless. You've gone above and beyond with your help with this thesis and it would not be as well written or anywhere nearly as aesthetic without your input. But most importantly, exploring Durham and Austin, meeting new people, seeing new places, drinking new cocktails and embarking on this adventure has been indescribably better for having you alongside me. During our PhDs, between us, we've worked or lived in Lancaster, Bristol, Brighton,

Oxford, Brazil, Zambia, Manchester, Durham and Austin, we gotten engaged and married, become godparents and aunties and uncles, been on road trips, got postdocs, (whisper it) turned 30, and as the zenith, are now thinking about buying a sofa (still can't bring myself to do it). You've worked so hard to get where you are and, in turn that has helped me to get where I am. I cannot wait to embark on this next adventure with you.

To my family. None of you know what I do, and why I hang around with apes or children. But I appreciate the endless links to chimpanzees playing football, magicians showing primates tricks on iPads, or orangutans sawing wood. To my mum, Naomi, for having to put up with me and doing such a laudable job of it (not that I turned out well, but you tried). Your maternal instincts have meant that I now know to add nail polish remover to my bracelets, to hang my shirts in the bathroom to get rid of creases (absolutely never do that, but handy nonetheless) and the relentless thermals in my Christmas stockings saved my life when the 'Beast from the East' arrived during the depths of writing. Your strength of character will always inspire me. To my dad, Nick, for your unwavering support throughout my academic career (and steadfast supply of cricket tickets and cider). Without yours and Sally's generosity and backing I would not be in this position. You've provided constant encouragement and kindness (and excellent hosting) to me since I moved to Plymouth for my undergraduate degree, and I hope that one day I can repay that and strive to do so. I undoubtedly acquired much of my work ethic from you and that has aided me to the position I am in now. To all of my brothers and sisters: Byron, Jade, Jules, Brooke, Paige and India – you have all accepted that I will keep moving as far away as possible from you (Plymouth-York-Lancaster-Brighton-Brazil-Zambia-Manchester-Durham-Texas-South America) but throughout it all we have maintained amazing relationships, and it's been a privilege to welcome new members to the family. And especially, to my twin brother Ross. You have had a remarkable ability to be almost uncontactable throughout this PhD, but whenever I need a chat, a room,

a coffee or a 30 meter sprint race in Istanbul airport (dusted you), you've been around on over 25% of occasions. I'll always be sad to be away from you all, but you make coming back so enjoyable.

To the staff at the NCCC. Everyone was so welcoming, friendly, helpful and knowledgeable. From filling out personality forms and retrieving broken puzzle-box bits, to cutting down Christmas trees while drinking whiskey hot chocolates and wearing sunglasses. I could not have collected the data or have had some much fun without you guys. Particular thanks go to Lisa Reamer for all of her help with data collection and logistical advice, to Kassie, Amanda F, Dana and Jayne for their continual good spirits in helping me set up apparatus, to Will Nyberg II for his incredible and selfless help constructing/repairing puzzle-boxes (hoped the beers helped), to MC for her unremitting fun, to Gill Vale for advice on Austin and on chimpanzee experiments, and to Steve Schapiro for logistical help, hospitality and his new-found interest in cricket.

I thank the Economic and Social Research Council for whom without their financial support this thesis would not be possible. I also thank the CCBC, EARG and Primatology research groups at Durham University for lively and interesting discussions and feedback on mine and others' work (on campus or in pubs).

To all the schools I worked in and to the children and parents who agreed to participate. Your help, interest and friendliness made it easy to haul a massive box around the North East for months on end. I have a new-found appreciation for the commitment of primary schools to scientific endeavour, and to parents' interest in a mad looking, bearded, curly haired men carrying around an array of odd looking things. Without your approval and interest, we could not conduct the research that we love.

To my UK friends; old and new. The boys from Diss and Plymouth have provided enough weekends of forgetting about work (and as a result of nights out, forgetting everything – that stag do) to keep me going. The guys from Lancaster have been just amazing companions and your advice on PhD life has been invaluable. Beth, Ollie, Diana, David, Kirsty and Jim in particular have been incredibly generous hosts and friends. I always look forward to seeing all of you guys and you'll always be welcome wherever we have a house. My peers and friends in Durham have made moving away so difficult but coming back so fun, especially Leah Findley, Zarja Mursic, Simone Lemmers, Marco Nebbia, Stefano Vaglio, Jamie Tehrani and Alex Hudson. We have had a lot of fun, and I hope our paths cross frequently in the future.

To my Texan friends; thank you for making this so much fun and for making it so easy to move here for longer. To Christine and Joel, MC, Justin and Nicole, Gill Vale and Lisa Reamer for their warmth and fun nights out. Tim Morilla, Ah Deckland, Robert Siekmann, Pete O'Dowd, Matt Paris and the rest of the ATX soccer team for all the good times so far and for making me feel so valued on the football (soccer) pitch, and thanks in advance for all the future fun.

This thesis is dedicated to Alpha, Kiht, Nahja and Cordova.

Thesis Abstract

Innovation and social learning are the dual pillars of cultural evolution, yet we know little about individual differences in propensity to use these learning strategies. This thesis investigated whether intrinsic and extrinsic individual differences predict the use of social or asocial information when faced with novel problems, from a developmental (children) and comparative (chimpanzees) perspective. Using an experimental approach, both species were presented with novel, multi-action puzzle-boxes, and measures of personality (children and chimpanzees) and social network positions (children) were collated and correlated with learning strategy use.

Overall, children showed a comparatively greater reliance on social information than chimpanzees; while the majority of seven- to 11-year old children explicitly elected for social information when it was offered, most chimpanzees interacted with a puzzle-box where asocial learning was required before one offering social demonstrations, and chimpanzees' puzzle-box behaviour was not influenced by three different forms of social information (video demonstrations of 'conspecific hands', human demonstrations and observations of conspecifics during task interaction). Personality (agreeableness, openness to experience and conscientiousness) was an important predictor of children's learning strategies, both in terms of children's overt choice for and fidelity to witnessed behaviours. By contrast, while there was tentative evidence that ratings of dominance predicted the propensity to observe video demonstrations, personality otherwise was not correlated with chimpanzees' learning strategy behaviours. Additionally, children identified as having many social connections were more innovative both in terms of asocial exploration and deviation from adult demonstrations.

Certain themes also emerged throughout this thesis; children displayed a negative age-related trend in the propensity to use social information. In both children and chimpanzees, females showed a greater

propensity to acquire social information, while the use of multiple tasks revealed novel insights into consistencies in cross-task performance in terms of both children's innovative behaviours and chimpanzees' use of different types of social information. Specifically, children who overtly elected to solve a novel puzzle-box asocially were more likely to manufacture a tool on an innovation challenge and scored higher on a measure of creativity, compared to children who elected for social demonstrations. In chimpanzees, observations of video demonstrations were correlated with observations of human demonstrations, as was the propensity to observe conspecifics during task interaction across both experiments. By revealing cross-species similarities and differences concerning how personality and social network positions predict learning strategy use, this thesis sheds new light on how cultures emerge and establish, and the evolutionary trajectory of human culture. The methodological and cultural implications, as well as potential future directions, are discussed.

Chapter 1: General Introduction

1.1 Introduction

Humans are the most cultural species on earth. We acquire a myriad of behaviours, skills and customs through cultural transmission, which has shaped our existence and ability to inhabit most areas of our planet. Exactly how our cultural repertoire originated is still debated among scientists. To fully understand this, we must understand how cultures emerge and establish, the underlying mechanisms involved, and the evolutionary origins of human culture. This can be done by firstly, comparing our species with others to tease apart similarities and differences in underlying mechanisms and behaviours. Long-term research has shown that our joint-closest phylogenetic relatives (along with bonobos, *Pan paniscus*), chimpanzees (*Pan troglodytes*), are also (among) our closest cultural relatives, displaying several population-specific behaviours purportedly passed on through social transmission (Whiten, 2017b; Whiten et al., 1999). These behaviours are certainly analogous (and some argue homologous – see Laland & Galef, 2009) to human culture, providing an ideal comparison point for investigating the evolutionary origins of our culture. Secondly, investigating the ontogeny of human cultural behaviours allows examination of how relevant mechanisms, behaviours and cognitive abilities are acquired, developed, and displayed through childhood.

Key to our cultural success is the effective use of specific learning strategies, defined here as an individuals' reliance on asocial or social learning (of any form) when faced with novel problems to solve or skills to acquire (Kendal, Coolen, & Laland, 2009). Social learning involves acquiring behaviours through observing or interacting with others or their products and provides rapid and efficient knowledge acquisition. Asocial learning (also termed in this thesis individual or personal learning) involves acquiring behaviours individually, providing direct, reliable environmental information.

Asocial learners innovate new behaviours, and social learners facilitate their dissemination throughout populations. As such, social learning and innovation (individual generation and implementation of new solutions to problems; [Carr, Kendal, & Flynn, 2016]) have been termed the two driving forces of human culture (Legare & Nielsen, 2015).

The aim of this thesis is to explore intrinsic and extrinsic individual differences¹ that may predict the use of social or personal information when faced with novel problems, in human children and chimpanzees. The overarching framework of the thesis is cultural evolution; both asocial and social learners are essential for the development and diffusion of new traditions within populations (Flynn & Whiten, 2010; Legare & Nielsen, 2015; Navarrete, Reader, Street, Whalen, & Laland, 2016; O'Brien & Shennan, 2010). Understanding whether some individuals are more likely to individually innovate new behaviours or skills, while whether others are more likely to socially disseminate such innovations will bridge a gap in our understanding of how new cultural behaviours emerge and establish in populations. I will take developmental (children) and evolutionary (comparative) approaches by examining whether intrinsic and extrinsic factors shape the propensity to use specific learning strategies. Specifically, I will use an experimental approach to investigate whether underlying personality (intrinsic) and social network positions (extrinsic) influence the learning strategies children, and chimpanzees adopt, when faced with novel problems.

1.2 Learning strategies

Both social and asocial learning are crucial for the development and survival of many animal species (Kaufman & Kaufman, 2015; Kendal et al., 2009; Laland, 2004; Rendell et al., 2010). Young children

¹ Throughout this thesis, I use the term individual differences to refer to stable personal characteristics (such as personality, position within a social network, working memory or IQ), as opposed to more transient state-dependent factors (such as environmental context (social and non-social), reproductive state and so on).

and chimpanzees must learn how to navigate their physical and social environment through observing and interacting with others, and subsequently acquiring and repeating witnessed behaviours. Without the opportunity to do so, individuals often fail to acquire essential skills in the physical (Matsuzawa et al., 2008) and social domains (Pettigrew, 2002). Copying others is also crucial for maintaining within-group homogeneity and cultural variation across populations. Equally, asocial innovation allows individuals to successfully tackle novel tasks and problems, and to adapt to new ecological challenges that emerge over time (Sol, Duncan, Blackburn, Cassey, & Lefebvre, 2005). Innovation is also essential for improving the efficacy of existing skillsets, driving - particularly in the case of humans – technological development (Dean, Vale, Laland, Flynn, & Kendal, 2014). In short, social learning and innovation are fundamental to both the fitness of a population and to its cultural evolution.

However, each strategy has associated costs. Social information may be outdated and unreliable, while individual sampling can be time-consuming and is often a risky strategy. Indiscriminately copying others may lead to acquiring maladaptive or harmful behaviours while (for example) attempting to learn which foods to eat asocially may result in sickness, injury or predation. Computer modelling (Kempe & Mesoudi, 2014) and experimental work (Kendal, Giraldeau, & Laland, 2009) have shown that successful populations require a balance between individuals who display higher frequencies of asocial and social learning. Individuals thus face a trade-off in solving problems socially or asocially (Kendal et al., 2009).

As well as posing costs and benefits, each strategy also requires specific skillsets. Effective social learning often requires assessing the competence and intentions of demonstrators, and evaluating behaviours they display (Wood, Kendal, & Flynn, 2013). Learning from others is also often facilitated by a positive relationship between learner and demonstrator (Coussi-Korbel & Fragaszy, 1995). In contrast, asocial learning requires innovation and creativity to derive a solution without information

from others (Bateson & Martin, 2013). Although any given learning event may involve a combination of both social and asocial learning (Carr et al., 2016; Muthukrishna & Henrich, 2016), the different skillsets required for each strategy means it is plausible that there will be individual differences in the propensity to solve problems socially or asocially. Indeed, a small but growing body of research over recent years has indicated that across a range of taxa, including humans, individuals differ in their propensity to adopt social or asocial learning when facing novel problems (Carter, Marshall, Heinsohn, & Cowlshaw, 2014, 2013; Kurvers, van Oers, et al., 2010; Molleman, van den Berg, & Weissing, 2014; Toelch, Bruce, Newson, Richerson, & Reader, 2013; Toyokawa, Saito, & Kameda, 2017). To date, however, very little is known about what exactly may underlie these individual differences. Thus, a fundamental question that remains unanswered is whether there are any individual-level factors that predict the use of specific learning strategies in humans and nonhumans (Mesoudi, Chang, Dall, & Thornton, 2016; Morand-Ferron, Cole, Rawles, & Quinn, 2011; Rawlings, Flynn, & Kendal, 2017). Specifically, we know very little about *who are the innovators and who are the social learners?* The aim of this thesis is to bridge this gap by empirically examining individual level factors underlying learning strategy choice in two primate species.

1.3 Approaches to studying learning strategies

Over several decades researchers have amassed an impressive body of research on social and asocial learning in both humans and nonhuman primates. We now know, for example, that humans and chimpanzees display biases dictating the contexts in which they copy others (Kendal et al., 2015; Wood et al., 2013), species similarities and differences in mechanisms underpinning learning strategies (Whiten, McGuigan, Marshall-Pescini, & Hopper, 2009), and that for many animal species, including humans, individually innovating solutions to novel problems appears to be a difficult and late-developing process (Cutting, Apperly, & Beck, 2011; Tennie, Call, & Tomasello, 2009). Additionally,

there has been a recent shift in the dichotomous approach to investigating learning strategies.

Traditionally, social and asocial learning have been studied separately, with researchers interested in either one construct or the other. Recent studies directly investigating both asocial and social learning in tandem have shed new light on our understanding of the tendency to use specific learning strategies, at an individual and species level (Flynn, Turner, & Giraldeau, 2016; van Leeuwen, Call, & Haun, 2014).

There are two main approaches to studying how and when individuals use specific learning strategies: 1) observations of naturally occurring instances and 2) controlled experiments. Direct observations of naturally occurring cases of learning strategies provide ecologically valid, in-situ information about the conditions in which individuals tend to use social or asocial learning. For example, cases of young chimpanzees watching older conspecifics crack nuts open before attempting themselves (Biro et al., 2003; Inoue-Nakamura & Matsuzawa, 1997), or young children learning to use cutlery by watching older peers (Barrett, Davis, & Needham, 2007), suggest that these behaviours require refining techniques based on observing and copying others. Although occurrences of social learning in natural conditions arise relatively often (compared to innovation), given the lack of control afforded, it has historically been difficult to exclude alternative non-social learning explanations (Kendal et al., 2010; Laland & Janik, 2006), or to attribute specific underlying cognitive processes (Flynn & Whiten, 2010). However, recent technological and statistical developments have allowed scientists to quantify the diffusion of behaviours across group members and attribute the pattern of dissemination to social learning (Allen, Weinrich, Hoppitt, & Rendell, 2013; Hobaiter, Poisot, Zuberbühler, Hoppitt, & Gruber, 2014; Mann, Stanton, Patterson, Bienenstock, & Singh, 2012). In contrast, the relative rarity of innovations in natural contexts means researchers are seldom present to document the very first instance of a new behaviour, making this a particularly difficult and laborious approach to study innovation (Lamon, Neumann, Gruber, & Zuberbühler, 2017). There are some cases where the first instance of a

behaviour have been documented, including where the spread of foraging innovations have been documented in wild chimpanzees (Hobaiter et al., 2014), and even a case where the diffusion of an arbitrary non-foraging behaviour (putting grass in ears) across a group of semi-wild chimpanzees has been traced from its origins (van Leeuwen, Cronin, & Haun, 2014). Given the rarity of such instances, however, collation of reports of innovation from the literature provides a valuable method for comparing rates of innovation within and across species, as has been done in birds and nonhuman primates (Lefebvre, Whittle, Lascaris, & Finkelstein, 1997; Reader & Laland, 2001).

Thus, some questions remain difficult to examine through observations of individuals in completely natural contexts. For instance, it is almost impossible to definitively ascertain the conditions in which individuals favour one learning strategy or another, why this might be, or which individuals are more likely to consistently favour one strategy over another (and what may differentiate such individuals). The experimental approach - typically involving presenting novel challenges to individuals and recording their behaviours - overcomes some of these difficulties. Under controlled conditions, researchers can directly probe questions such as those outlined above and observe and track seeded innovations. Novel tasks, particularly puzzle-boxes (often termed 'artificial fruits'), which individuals interact with (either with or without tools) to attempt to retrieve rewards are widely used in comparative experiments investigating social and asocial learning. The experimental approach has revealed that numerous animal species, including human and nonhuman primates (hereafter primates), are remarkably adept at acquiring behaviours through observing others and can faithfully maintain seeded puzzle-box solutions across several generations and groups through social learning (Dindo, Stoinski, & Whiten, 2011; Flynn & Whiten, 2012; Hopper, Schapiro, Lambeth, & Brosnan, 2011; Whiten, Caldwell, & Mesoudi, 2016). In contrast, asocially innovating solutions to novel problems in experimental settings is particularly difficult; when presented with a range of innovation challenges, research has shown both

children and chimpanzees struggle to arrive at a solution (Beck, Apperly, Chappell, Guthrie, & Cutting, 2011; Carr, Kendal, & Flynn, 2015; Hanus, Mendes, Tennie, & Call, 2011; Nielsen, 2013; Tennie et al., 2009). Thus, controlled experiments have highlighted important cross-species similarities in learning strategy use in ways that natural observations could not achieve.

The recent experimental integration of social and asocial learning has also provided a new dimension to our knowledge of how individuals employ each form of learning, and indeed species-differences in the trade-off made between them. For example, when directly pitted against one another, children strongly prefer to observe others before attempting to tackle novel problems themselves (Flynn et al., 2016), while chimpanzees seem to place less value on social information than children do (Vale et al., 2017; van Leeuwen, Call, et al., 2014). These findings are in keeping with earlier theoretical work suggesting humans show a strong inclination for social information while nonhuman animals appear to use social information as a ‘back up’ strategy, when individually-obtained information is unreliable (Templeton & Giraldeau, 1996) or costly to acquire (Boyd & Richerson, 1985; Kendal et al., 2015, 2009). Recent experiments have also highlighted that individuals differ in their propensity to use social or asocial information: studies have shown that in human and nonhuman animals alike, a range of factors including cultural background, IQ (humans), developmental stress (nonhuman animals), personality and social network properties (human and nonhuman animals) all influence the propensity to rely on social or asocial information (see Mesoudi, Chang, Dall, & Thornton, 2016; Rawlings et al., 2016). These findings and their implications will be discussed in detail in sections 2.5, 2.6 and 2.7.

1.4 Aim and Structure of this Thesis

This thesis will build upon the developments above by being the first to investigate individual differences in learning strategy by comparing human children and chimpanzees. The literature review

(Chapter 2) will explore and compare the literature on social and asocial learning across humans, chimpanzees, and other nonhuman animals. Chapter 3 provides an outline to, and justification for, the general methods used throughout this thesis. The first empirical study in Chapter 4 will investigate the relationship between personality and learning strategies in children, and Chapter 5 investigates the relationship between children's social network positions and their learning strategies. Next, in Chapter 6, I present a longitudinal study on the stability of chimpanzee personality traits, before examining the relationship between personality and learning strategies in chimpanzees in Chapter 7. The thesis will end with a general discussion (Chapter 8). Throughout this thesis learning strategies in the physical domain, particularly tool use, will receive special attention. Physical tool use characterises all human societies, is an early-developing behaviour, is fundamental to human cultural evolution, and has been extensively studied in children and animal species (particularly chimpanzees, see Gruber, Clay, & Zuberbühler, 2010), providing an ideal basis for comparative cultural evolution research.

Chapter 2 Literature Review: Individual differences in children's and chimpanzee's use of social and asocial information: The role of personality and social network positions

This chapter provides a detailed review of the literature examining individual differences – with a particular focus on personality and social network positions - in the use of social and asocial information in humans and nonhuman animals.

Sections of the Literature Review, particularly those focussing on children, are adapted from a recent publication stemming from this thesis:

Rawlings, B., Flynn, E.G., Kendal, R.L. (2016). To copy or to innovate? The role of personality and social networks on children's learning strategies. *Child Development Perspectives*, 11(1): 39-44.

This article was a brief opinion piece on the potential for investigation personality and social network positions hold for cultural evolution researchers, particularly from a developmental perspective. As the article held a 2500-word count limit, it was not included in this thesis. However, I have extracted and modified certain sections to include them in the following literature review.

2.1 Introduction

The following review will present relevant literature on children and chimpanzee learning strategies. I start by exploring the literature on social learning and social information use in children and chimpanzees, before introducing the comparable literature on asocial learning and innovation in both species. Within the asocial learning sections, innovation will receive particular attention, owing to its importance to cultural evolution (Reader, Morand-Ferron, & Flynn, 2016). Next, I turn broadly to the subject of individual differences in the use of both learning strategies, before presenting the literature on two specific types of individual differences and how they may play a key role in the propensity to adopt specific learning strategies; personality and social network positions and properties. These factors have been chosen because a burgeoning body of studies stemming from other fields, most notably adult and nonhuman animal (hereafter animal) research have begun to suggest that they may be pertinent avenues for investigation in children and chimpanzees (Rawlings et al., 2017). The literature throughout will largely focus on human children and chimpanzees, as the thesis study species. However, where relevant, it will be supplemented with work on adults and other nonhuman animals. As alluded to, in keeping with the traditional approach the literature on social and asocial learning will be presented separately - although I recognise the recent work has acknowledged that there is much overlap between the two learning strategies (Carr et al., 2016; Henrich, 2015), and indeed, the social influences on innovation will be empirically addressed in this thesis. Finally, the cultural evolution literature frequently incorporates closely linked constructs which are occasionally used interchangeably. For clarity, below is a glossary of several such terms which are frequently used throughout this thesis denoting their definition as used herein.

Glossary

Social learning: In the broad sense, social learning is defined as learning influenced by the observation of, or interaction with another individual or their products (Box, 1984; Heyes, 1994).

Imitation: Imitation denotes the exact replication of observed behaviours. In this thesis, it refers to exactly matching the actions of a demonstration.

Trial and error learning: Trial and error learning is learning through repeated (often varied) attempts until either the individual arrives at a solution (not necessarily with a causal understanding of the task/solution) or ceases their attempts (Ghirlanda & Lind, 2017).

Divergent Thinking: Divergent thinking is the act of searching for novel ideas (Guilford, 1967).

Creativity: Creativity denotes the generation of novel ideas or behaviours that are both original and effective (Diedrich, Benedek, Jauk, & Neubauer, 2015; Runco, 1992).

Exploration: Exploration in its broadest sense can be any form of information collecting activity. This can be activities aimed towards an immediate, tangible goal (extrinsic exploration), or activities not directly aimed towards an overt goal (intrinsic exploration; Reader, 2015).

Innovation: This thesis uses the term innovation in reference to the physical domain. Following Carr et al. (2016), here, innovation is a novel, valuable and *potentially* transmitted behaviour that can result from either asocial learning (innovation-by-invention) or through modifying previously observed behaviours (innovation-by modification), which is generated in order to solve a novel problem, or to solve an existing problem in a novel way.

Problem solving: Generating a solution to a novel task, which can be through asocial or social endeavours. In this thesis, problem solving refers to the physical domain; typically measured by presenting novel, reward-baited apparatuses to individuals (Griffin & Guez, 2014).

2.2 Social learning and social information use

Social learning underpins culture (Boyd, Richerson, & Henrich, 2011). Learning from others allows ideas, beliefs and behaviours to rapidly disseminate throughout populations, as well as providing a ‘cheap’ source of information about many life skills, such as how to navigate novel environments, what to and not to eat, or how to use particular tools (Jaeggi et al., 2010; Want & Harris, 2001). Importantly, high-fidelity social learning allows cultural traits to be maintained within groups. As such, social learning has been the focus of intense research over recent decades (e.g. Boyd & Richerson, 1983; Brown & Laland, 2003; Dean, Kendal, Schapiro, Thierry, & Laland, 2012; Flynn & Whiten, 2010; Rendell et al., 2010; Rogers, 1988). Accordingly, we now have a vast catalogue of information on the conditions in which social learning occurs, the underlying cognitive processes involved (and potentially the neural mechanisms; Heyes, 2011), and a detailed comparative perspective of social learning (Price, Wood, & Whiten, 2017; Whiten, 2017b).

2.2.1 Children’s social learning and social information use

Social learning plays a fundamental role in a variety of different domains across development, providing children with knowledge about social relationships (Pettigrew, 2002), language (Foster, Lambert, Abbott-Shim, McCarty, & Franze, 2005), and how to interact with the objects and artefacts around them (Nielsen, Cucchiaro, & Mohamedally, 2012; Reindl, Apperly, Beck, & Tennie, 2017). Across cultures, children are exceptional social learners, readily acquiring information from others within the first year of life (Meltzoff & Moore, 1989), and throughout childhood (Clegg & Legare, 2016; Hewlett, Fouts, & Boyette, 2011; Wood et al., 2013). To date, much of the scientific focus has been on investigating characteristics of demonstrators that children copy (*who strategies*), the conditions under which they may copy others (*when strategies*) and the underlying mechanisms involved in children’s social learning (*social learning processes*). Consequently, we now know that children show a strong propensity to copy

others (McGuigan & Robertson, 2015), and that situations such as uncertainty (Carr et al., 2015; Wood et al., 2016) can increase the tendency to copy others. We know that children preferentially copy demonstrators with particular characteristics, such as those who are the same sex, older, and that have been previously successful (see Price et al., 2017; Wood et al., 2013a). We also know that children are capable of high-fidelity imitation (Dean et al., 2012; Flynn & Whiten, 2008), can faithfully maintain traditions across several generations (Flynn, 2008; Whiten, Caldwell, et al., 2016), and will even copy obviously irrelevant actions (Chudek, Baron, & Birch, 2016; Nielsen, Mushin, Tomaselli, & Whiten, 2016)

Given children's exceptional imitation capacity, it seems likely that they would prefer to obtain social information when it is available, over attempting to develop solutions to problems asocially. Explicitly pitting social and asocial information against each other offers a direct method to investigate the propensity to adopt specific learning strategies. Flynn et al., (2016) presented three- to five-year old children with a reward-baited puzzle-box and offered participants the option of attempting to solve it themselves (asocially innovate solutions) or observing an adult demonstration of the solution first (social learning). Irrespective of task difficulty, 69% of three-year olds and 82% of five-year olds elected for social demonstrations, thus showing a strong overall preference to look to others when facing a novel problem. This preference for social information holds even when the information is demonstrably unreliable, and if children have already obtained adequate personal information. For instance, despite having observed a demonstrator repeatedly fail a puzzle-box task, and having a range of alternative solutions, four- to nine-year old children still showed striking fidelity to the witnessed method (Carr et al., 2015). Similarly, five year old children who had previously individually obtained solutions to a puzzle-box still predominantly adopted the (different) solution demonstrated by a model (Wood, Kendal,

& Flynn, 2013). This corresponds with much work on ‘overimitation’ in children - the tendency to faithfully copy actions that are causally irrelevant (Chudek et al., 2016; Lyons, Young, & Keil, 2007).

Children’s proclivity for social learning likely serves several purposes. First, it allows children to rapidly learn how to navigate our complex, tool-rich environments (Legare & Nielsen, 2015). Copying exactly as others do likely facilitates quick acquisition of difficult to learn instrumental skills without requiring a complete understanding of their causal underpinnings (Lyons et al., 2007), perhaps by employing a ‘copy-all-now, refine-later’ strategy (Whiten et al., 2009). High fidelity copying may also serve social purposes, helping children fit with their surrounding social environment, acquire social conventions, and ‘be like others’ (Evans, Laland, Carpenter, & Kendal, 2017; Morgan, Laland, & Harris, 2014; Over & Carpenter, 2013). Indeed, it is likely that a combination of the two motivations underpin children’s copying behaviour; recent work has shown that manipulating contextual factors, such as task transparency and demonstrator communicativeness influences whether children behave in accordance with the causal or social accounts (Schleihauf, Graetz, Pauen, & Hoehl, 2018).

2.2.2 Chimpanzee social learning and social information use

As with children, social learning represents an integral aspect of chimpanzee development and life. Chimpanzees learn from others about social relationships (Goodall, 1986), social behaviours (Bonnie & de Waal, 2006; van Leeuwen, Cronin, Haun, Mundry, & Bodamer, 2012) and foraging techniques (Rawlings, Davila-Ross, & Boysen, 2014), including those requiring complex tool use (Gruber, Muller, Strimling, Wrangham, & Zuberbühler, 2009; Horner, Whiten, Flynn, & de Waal, 2006; Luncz, Mundry, & Boesch, 2012). Moreover, social learning is thought to underlie the extensive repertoires of group-specific traditions exhibited by wild chimpanzees across Africa (Whiten, 2017b). Owing to their complex social dynamics and close phylogenetic and cultural proximity to humans, chimpanzees make

an excellent candidate species for comparative research (Whiten, 2017b; Whiten et al., 2009). Chimpanzees and children show many similarities in their social learning behaviours. Like children, chimpanzees are capable of faithfully maintaining experimentally seeded traditions across multiple generations (Horner et al., 2006; Whiten et al., 2007) and between groups (Whiten et al., 2007). Moreover, chimpanzees also show a range of adaptive social learning strategies, influencing that they copy in (for example) conditions of uncertainty (Hirata & Morimura, 2000), and there is some limited evidence that they preferentially copy knowledgeable, dominant (Horner et al., 2010; Kendal et al., 2015) and familiar (de Waal, 1998) conspecifics – although more work is needed to verify these findings. These strategies are thought to play a similar role to that in children, affording quick and reliable information acquisition, often resulting in maintenance of within-group homogeneity (Laland, 2004).

Despite these similarities, chimpanzees also significantly differ from children in some social learning behaviours. Most pertinent here is chimpanzees' relative propensity to adopt social or asocial information when pitted against one another. Although very few studies have directly examined this, it appears that compared to children, chimpanzees are more likely to use personal information (information gathered themselves) over explicitly copying others. van Leeuwen et al. (2014) and Vale et al. (2017) provided children and chimpanzees with conflicting personal and social information on a hidden-reward task and token exchange task, respectively. Children showed a significantly greater reliance on others' behaviours than chimpanzees, who exhibited comparatively little use of social information in both studies. Vale and colleagues trained captive individual chimpanzees to avoid foods of certain colours - by making them unpalatable - and to consume foods of other colours - for instance, avoid orange food, eat green food (Vale, Davis, et al., 2017). Simultaneously, other groups of chimpanzees, to whom the individuals were to be migrated in to, were trained on the reverse food

patterns (avoid green, eat orange). When individuals were introduced into their new groups, they stuck with their initial personal information (green food), despite observing the rest of their new group consume previously unpalatable food (who also stuck to their learned food preference). Thus, migratory chimpanzees relied on individual information over social information, and failed to adopt the food preference of their new social groups (although see van de Waal et al. (2013) and Luncz, Wittig, & Boesch [2015] for evidence of wild vervet monkeys socially adopting colour-food preferences, and an migrating female adopting the tool materials of her new population in the Taï Forest, respectively).

These studies indicate that chimpanzees place less value on conspecifics' behaviours in new situations than children do. This may underlie a tendency for chimpanzees (and many other animal species) to use social information only as a backup strategy when personal information is highly unreliable and/or risky (Rieucau & Giraldeau, 2011; Templeton & Giraldeau, 1996; van Bergen, Coolen, & Laland, 2004; van Leeuwen et al., 2014). This tendency may partly underlie the 'cultural gap' between humans and chimpanzees (Call, Carpenter, & Tomasello, 2005; Carpenter & Call, 2009; van Leeuwen, Call, et al., 2014), as socially acquiring innovations that arise will better allow the spread of novel cultural variants, facilitating behavioural diversity (van Leeuwen, Call, et al., 2014)

Another difference between the two species is their relative copying fidelity. As previously highlighted, children are remarkable copiers, even in the face of causally irrelevant or unsuccessful actions (Carr et al., 2015; Lyons et al., 2007). Chimpanzees, in contrast, omit obviously causally irrelevant actions, copying only actions that directly lead to reward retrieval. For instance, when presented with novel puzzle-boxes and social demonstrations of causally necessary and unnecessary actions (such as tapping the top of the box), if the puzzle-box is transparent (so that individuals can see the causal consequences of their actions), chimpanzees, but not children, will only copy causally relevant actions (Horner &

Whiten, 2004). As such, chimpanzees appear to copy on the basis of prioritising the result, while humans are more concerned with the ‘way things are done’ (i.e. the normative functions of behaviours; (Call et al., 2005; Carpenter & Call, 2009; Nielsen & Tomaselli, 2010). This difference may also contribute to the difference in cultural variation between the two species: humans display a vast array of social and technological activities requiring various distinct methods across populations. Attending to the precise methods provides crucial information about the cultural traditions of behaviours, and copying them ensures that cultural differences remain between populations (Nielsen & Tomaselli, 2010). In attending largely to the outcome, chimpanzees limit the cultural diversity they can achieve.

In sum, both humans and chimpanzees rely extensively on social learning throughout their lifespans. However, and importantly, children show a greater reliance on social information over individually acquired information, while the opposite appears to be true for chimpanzees. These findings may explain the cultural separation between humans and chimpanzees; humans’ high-fidelity social learning behaviour may enable them to incorporate observed innovations into their existing skillset, facilitating a wider and ever-advancing cultural repertoire. In contrast, chimpanzees’ more restricted copying propensities may inhibit the spread of novel variants, limiting their cultural inventory. However, key to cultural evolution is that individuals in both species do engage in innovation, and it is this topic to which I turn to next.

2.3 Asocial learning and innovation

Asocial learning, the other half of the learning strategies coin, involves individually acquiring behaviours and skills without the use of social information, through processes such as trial and error learning and individual innovation. Individually-innovated behaviours provide responses to novel challenges and lay the platform for new and potentially more advanced cultures to emerge, promoting

cultural change (Legare & Nielsen, 2015; Reader et al., 2016). Innovations underlie humans' extraordinary success in colonising the planet but are also relatively widespread across the animal kingdom. Consequently, research on human and animal innovation is becoming extensive (Henrich, 2015; Navarrete et al., 2016; Reader & Laland, 2003; Reader et al., 2016). Within nonhuman animals, primates are among the most frequent and wide-ranging innovators in natural conditions; there is now a large database of documented primate innovations (Hopper, 2016; Navarrete et al., 2016; Reader & Laland, 2003; van Schaik et al., 2016) and we know much about the contexts in which primate innovation tends to occur (Reader et al., 2016). Surprisingly, only recently has human innovation from a developmental perspective received notable scrutiny. This recent interest has, however, begun to furnish a greater understanding of the underlying processes of children's innovation, its developmental trajectory and the similarities and differences between humans' and animals' innovative behaviours (Carr et al., 2016).

Traditionally, innovation has been defined as an asocial process, directly opposing social learning. However, the current focus on innovation from developmental psychologists has also facilitated a revision of this view (Carr et al., 2016). It is increasingly understood that innovation can be separated into two forms: innovation-by-invention - a predominantly asocial process, and innovation-by-modification, the modification of previously observed behaviours (Carr et al., 2016; Dean et al., 2014; Flynn et al., 2016; Heyes, 2016; Hopper, 2016; Muthukrishna & Henrich, 2016). This development has begun to allow researchers to distinguish and separately examine asocially- and socially-mediated innovations, and children's tendencies to engage in either forms (Carr et al., 2015). Given that this is a recent development however, my review of the literature shall treat innovation as innovation-by-invention (as measured by asocial problem solving [Griffin & Guez, 2014]), unless explicitly stated.

It is also important to note that the term innovation has several closely tied constructs, including creativity (the generation of novel ideas or behaviours) and divergent thinking (the ability to search for new ideas), both of which are potential precursors to innovation (the *implementation* of creative ideas; Bateson & Martin, 2013; Carr et al., 2016). Humans exhibit individual differences in these constructs (Batey & Furnham, 2006), as do animals in creativity (Kaufman & Kaufman, 2015). The creativity-innovation link is notably close in both humans and animals (Bateson & Martin, 2013; Kaufman & Kaufman, 2015), and as such, these constructs - particularly creativity - will also be considered throughout the review on innovation and asocial problem solving.

2.3.1 Children's asocial learning and innovation

Children innovate across multiple domains, including play and games, interacting with objects (such as toys, tools and artefacts) and language. Indeed, childhood is often a period of unprecedented exploration, creativity and of rapid tool-use acquisition (Kelemen, Seston, & Saint Georges, 2012), thus providing ample opportunities for innovative behaviours (Bateson & Martin, 2013). The developmental approach allows researchers to quantify and capture the developmental trajectory of innovation. Despite the opportunities childhood provides for exploration and creativity, several studies indicate that young children find solving innovation challenges in experimental conditions remarkably difficult. The best-known example is the 'Hook Task', which requires individuals to fashion a hook from a pipe cleaner to retrieve a bucket (containing a reward) from within a transparent tube. Multiple studies have documented that, across cultures, the vast majority of children under eight years fail to manufacture a tool and retrieve the reward when instructed to do it themselves (Beck et al., 2011; Cutting, Apperly, Chappell, & Beck, 2014; Frick, Clément, & Gruber, 2017; Nielsen, Tomaselli, Mushin, & Whiten, 2014). Young children perform similarly poorly on other innovation challenges, including a modified versions of Aesop's Fable requiring pouring water into a tube to bring a toy within reaching distance

(Hanus et al., 2011; Nielsen, 2013), a task involving unbending pipe cleaners to reach a reward (Cutting et al., 2011), and a task requiring participants to form a loop from string to retrieve an out-of-reach reward (Tennie et al., 2009). This contrasts with children's striking social learning ability at the same age; when provided demonstrations in the Hook and water pouring tasks, children's performance was comparable to adults (Beck et al., 2011; Nielsen, 2013).

A combination of factors likely underpins children's difficulty on these types of tasks. Innovation challenges present children with the start (apparatus) and end states (retrieving the reward), but no information linking the two. This lack of information uniting the start and end state appears to pose considerable difficulties for young children (Cutting et al., 2014), and such tasks may be out of young children's 'zone of proximal development' (their cognitive capacity to solve tasks alone [Bruner, 1984]). In contrast, when given information about the means to bridge the start and end states, children readily succeed on innovation challenges. For instance, showing children a ready-made hook shape from the pipe cleaner facilitated adult-level success levels on the Hook Task (Cutting et al., 2014). Children also tend to fixate on the original purpose of tools (termed functional fixedness) and find it difficult to generate alternative uses for them. Learning a particular use for an object (e.g. using pipe cleaners in art projects) thus constrains their ability to invent new ways of using them (e.g. creating a hook, German & Defeyter, 2000). Additionally, pedagogical instructions such as explaining how objects should work can inhibit a child's willingness to explore and discover novel functions for objects (Bonawitz et al., 2011). These factors, coupled with children's strong preference for copying others probably impedes their capacity to innovate solutions to even relatively simple novel problems.

While key for highlighting children's difficulties with innovation, the studies above all focussed on innovation-by-invention. To date, just one developmental study has explicitly examined innovation-by-

modification. Carr et al. (2015) provided four- to nine-year old children with adult-demonstrations (of varying efficacy) of solutions to a novel multiple methods puzzle-box task (where rewards could be retrieved using a variety of tools in a variety of ways). Despite being given eight attempts each (and thus several opportunities for deviating from the observed methods) imitation was substantially the favoured strategy. Only 12% of children showed innovation-by-modification in a way that improved efficacy, and despite half of the participants observing demonstrations that were unsuccessful on 75%-100% of trials. However, older children were more likely to deviate from social information than younger children, potentially signifying that with maturing cognition, children are more likely to surmount functional fixedness (Carr et al., 2015). While more research is needed, this study does indicate that as with innovation-by-invention, modifying observed behaviours is an infrequent strategy for children.

2.3.2 Chimpanzee asocial learning and innovation

Chimpanzees are among the most frequent and well-documented innovators across the animal kingdom (Navarrete et al., 2016; Reader & Laland, 2001). Chimpanzees innovate across numerous contexts such as communication, foraging, play and dominance displays. The relatively high rates of innovation chimpanzees display are thought to underpin their comparatively diverse range of population-specific traditions (Biro et al., 2003; Whiten et al., 1999), despite the fact that far more innovations occur than spread within populations (Nishida, Matsusaka, & McGrew, 2009)

Experimentally investigating chimpanzee and other nonhuman animal innovation tends to follow the same approach as developmental methods; novel puzzles (often extractive-foraging tasks) are presented to subjects and their success and/or behaviours are observed. Studies using a variety of different tasks corroborate the results of those found in children; despite being relatively frequent innovators (within the animal kingdom) in natural conditions, chimpanzees tend to struggle with innovation-by-invention

challenges. For example, just five of 44 chimpanzees spontaneously solved a version of Aesop's Fable (Hanus et al., 2011) and all seven chimpanzees that took part in Tennie and colleague's (2009) string-loop task failed (Tennie et al., 2009). Similarly low success rates have been found in tool-modification tasks (Manrique & Call, 2011) and puzzle-box experiments requiring a sequences of actions to retrieve rewards (Davis, Vale, Schapiro, Lambeth, & Whiten, 2016; Dean et al., 2012; Vlamings, Hare, & Call, 2009). These low success rates are strikingly like those of young children on the tasks described previously, indicating that chimpanzees and children are matched in their capacity to spontaneously solve novel innovation challenges.

Most explanations of chimpanzee's difficulties with innovation tasks lean on cognitive factors. Tennie, Call and Tomasello, (2009, but see Whiten et al. [2009] for a critique of this view) argue that all animal species have a 'zone of latent solutions (ZLS)' – a set cognitive repertoire of physical skills (comparable to children's zone of proximal development). Actions such as loop-making fall outside of the repertoire of most chimpanzees' ZLS, and thus most individuals fail such tasks. Additionally, chimpanzees, like children, show some evidence that they are disinclined to learn and use new techniques to solve problems in which they already have a solution for (satisficing or conservatism) (Boesch, 2003; Davis et al., 2016; Gruber, 2016; Marshall-Pescini & Whiten, 2008; van Leeuwen & Call, 2016), and find applying previously-used objects in new ways difficult (functional fixedness) (Gruber, 2016; Hanus et al., 2011). For instance, Hanus et al. (2011) required chimpanzees to spit water into a tube to raise a peanut from the bottom enabling extraction of it. However, most chimpanzees were fixed on the original function of the water dispenser (drinking from it), inhibiting innovation of the solution (spitting water into the tube). It is probable that a combination of each of the above factors plays a role in chimpanzees' struggles with such tasks. Chimpanzees are likely to lack the cognitive repertoire to solve many

experimentally induced innovation challenges, particularly if they have already learned different solutions or uses for the apparatuses.

To my knowledge, no study has directly examined innovation-by-modification in chimpanzees. However, there is some evidence that chimpanzees can adjust formerly successful techniques, but only when forced to do so (i.e. if the present solution becomes invalid or markedly less efficient). For instance, studies have shown that chimpanzees (and other great apes) could switch to more efficient, and more complex techniques requiring combining previously used behaviours. Chimpanzees did this both individually (Manrique, Völter, & Call, 2013) and after demonstrations (Davis et al., 2016), although they did not do so unless their original technique was made substantially less efficient (i.e. costlier) or obsolete. Similarly, only after social demonstrations did chimpanzees disregard a straw-dipping technique in favour of a much more efficient straw-sucking technique to obtain juice from a small hole (Yamamoto, Humle, & Tanaka, 2013). Thus, chimpanzees possess the ability to modify existing behaviours to alternative, and even more complex ones. Importantly though, chimpanzees tend to remain faithful to their original methods unless the new techniques are significantly more efficient (also see Call, 2015) or unless they observe demonstrations with significantly improved rewards. It is unlikely chimpanzees would spontaneously display innovation-by-modification when current techniques preserve their efficacy levels and when tested asocially.

2.4 The role of context²

Before discussing individual differences in learning strategy use, it is important to acknowledge the role of context (state) aside from inherent individual differences. There is much evidence that the environment influences the learning strategies humans and animals adopt. Rendell and colleagues

² By context, I am referring to transient, state-dependent environmental (social or non-social) conditions.

identified three categories of context-dependent social learning strategies (see Figure 2.1; Rendell et al., 2011); 1) State-based biases, in which individuals are more likely to copy in conditions of uncertainty, and when personal information is unsatisfactory or unreliable. 2) Frequency-dependent biases, in which an individual's copying propensity is governed by the frequency of witnessed behaviours or models (i.e. copying the majority of demonstrators or copying the most frequently observed behaviours). 3) Model-based biases, in which characteristics of the model dictate copying propensity (e.g., copying prestigious, older or dominant individuals).

There is now large body of empirical support for these social learning biases. For instance, in both children and chimpanzees, model characteristics such as their reliability or perceived status affect the relative use of asocial or social information (Horner et al., 2010; Kendal et al., 2015; Wood et al., 2013). Conditions of uncertainty increase children's and chimpanzee's social learning proclivity (Kendal et al., 2015; Wood et al., 2016), while local ecological conditions also affect primate tool-use and innovation (Gruber, Zuberbühler, & Neumann, 2016; Spagnoletti et al., 2012). Context biases help individuals approach optimal levels of adaption quicker than an individual learning alone (Barkow, 1987). For a detailed discussion of how such contextual factors influence learning strategies, see Vale, Carr, Dean and Kendal (2017).

Despite the role of context, children and animals may differ in their inherent propensities for social or asocial learning. Across studies, few children or chimpanzees successfully tackle novel problems individually. Is the identity of this minority consistent and if so, what facilitates this success? Equally, are there underlying factors driving individual differences in the tendency to copy others? Without investigating whether the propensity to use specific learning strategies differs consistently by individual,

we cannot be certain whether context, individual-level factors, or a combination of both predict children's choices of learning strategy.

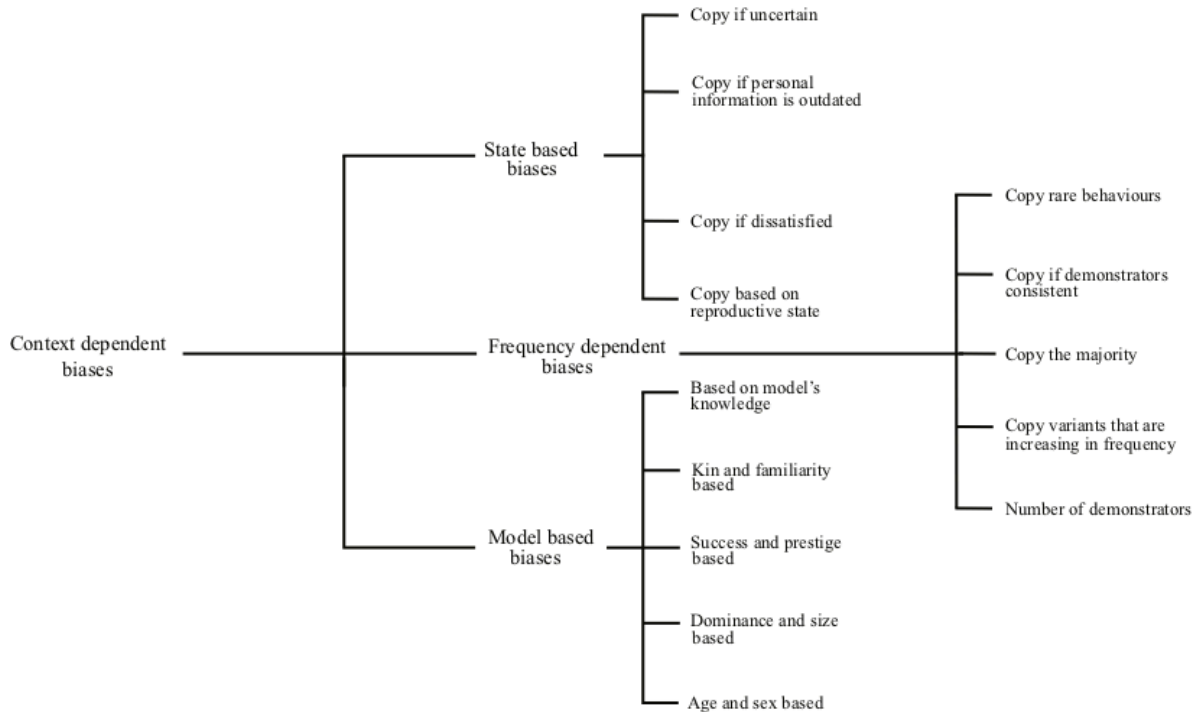

Figure 2.1: Adapted from Rendell et al. (2011); the three forms of context dependent social learning biases and their subcomponents.

2.5 Are there individual differences in human and animal learning strategies?

Overall, the literature indicates that the majority of children and chimpanzees find novel innovation challenges difficult. Most children will also elect for social information over individual information (Flynn et al., 2016), while chimpanzees appear to favour individually-acquired information (van Leeuwen, Call, et al., 2014). However, another interpretation of these results is that a *minority* of children will elect to ‘do it themselves’ - bypassing social information when faced with novel problems, and a *minority* can successfully innovate solutions to tasks that most of their peers find difficult. Equally, not all chimpanzees favour individually-acquired information, and in most studies outlined a *minority* did successfully innovate solutions to tasks that most conspecifics failed. This poses an

intriguing possibility that there may be underlying individual level differences, in both species, in the propensity to adopt, and success in using, specific learning strategies (Mesoudi et al., 2016; Morand-Ferron et al., 2011; Rawlings et al., 2017).

Individual differences in learning strategy use and success are understudied, particularly in children and chimpanzees. Despite some recent developments, we still have little knowledge of what, at the individual level, differentiates those showing a greater proclivity for social information, or for solving problems asocially. Though it is important to acknowledge that asocial and social learning are not necessarily dichotomous choices and that both learning strategies are available to all individuals (who can engage in either strategy), individuals may differ in their propensity to use either one. As such, the purpose of the following sections, and thesis in general, is to investigate whether there are intrinsic and/or extrinsic factors that predict the propensity to engage in either strategy, across tasks.

Owing to the lack of work on children and chimpanzees, I draw on relevant adult and other nonhuman animal studies investigating individual differences in the use of social or asocial information. I then discuss two types of individual differences that, based on the current adult and nonhuman animal work are particularly ripe for investigation in children and chimpanzees: personality and social network position.

2.5.1 Individual differences in social information use and social learning

Recent years have seen a growing set of evidence revealing systematic within-species, individual-level variation in social learning across humans and nonhuman animals (for a recent review, see Mesoudi, Chang, Dall, & Thornton, 2016). Adults and children consistently differ in their relative use of social information both cross-culturally (Clegg & Legare, 2016; Mesoudi, Chang, Murray, & Lu, 2014) and

within homogeneous populations (Molleman et al., 2014; Toyokawa et al., 2017). Similarly, both within and across nonhuman animal species, there are marked stable individual-level differences in the use of social information (Mesoudi et al., 2016). The growing body of research on individual differences and social information use now encompasses a variety of taxa as well as cognitive, physiological and social factors.

Human studies focusing on specific individual differences have found links between social information use and stable traits such as IQ (Muthukrishna, Morgan, & Henrich, 2015), infant-parent attachment style (Corriveau et al., 2009) and asocial learning ability (Mesoudi, 2011; Mesoudi et al., 2016). For example, in a line judgement task, adults' IQ showed a U-shaped relationship with social learning; higher and lower IQ individuals exhibited greater social learning, which the authors took to suggest that some (higher IQ) individuals strategically use social information (Muthukrishna et al., 2015). Relatedly, on a computer-based arrowhead design task with adults, strong social learners were also above-average individual learners (Mesoudi, 2011), suggesting a correlation between asocial learning ability and social information use. Infants' attachment style to their parents has also been correlated with social information use; children with different attachment styles (insecure-avoidant, insecure-resistant or secure) varied in their reliance on their mothers and strangers for social information in novel object identification tasks (Corriveau et al., 2009). The authors suggested that individuals with weaker attachment styles to their mothers are more likely to rely on individual information rather than seek information from their mothers.

Similarly, a range of individual differences predict social information use in animals. There is evidence, albeit mixed, that asocial learning ability is correlated with social learning ability in animals. Individual problem solving was positively correlated with social learning in pigeons and house sparrows, though

not in marmosets (see Mesoudi et al., 2016). Additionally, rats that experienced maternal deprivation (Lindeyer, Meaney, & Reader, 2013; Melo et al., 2006) exhibited lower than normal social learning levels, which may represent individuals using environmental cues to trigger responses in adjusting copying behaviours (Mesoudi et al., 2016).

There is thus now relatively strong support for consistent individual variation in social information use spanning adults, children and several animal species. Individual level factors known to influence human social learning include cultural differences, learning ability, IQ, and parent-infant attachment style, while in animals age, learning ability and physiological experiences and states shape social learning. This growing body of research has advanced our understanding of the individual level drivers of social information use and indicates that we need to be careful when generalising findings to all members of a species (Mesoudi et al., 2016). However, many of the results are inconsistent and difficult to straightforwardly compare across species. Direct species-comparable studies would fill a void in our understanding of whether there are consistent across species individual drivers shaping the propensity to use social information.

2.5.2 Individual differences in asocial learning and innovation

Behavioural studies investigating individual differences invoke innovation by presenting subjects with novel problems and trying to understand characteristics common to successful and unsuccessful individuals. Such studies have gained momentum in recent years across species, cultivating a greater understanding of which individuals are more likely to engage in, and be more successful at, innovation tasks.

In children, age (Beck et al., 2011) and receptive vocabulary - but not working memory or divergent thinking scores (Beck, Williams, Cutting, Apperly, & Chappell, 2016) - are positively correlated with success rates on the (innovation-by-invention) Hook Task. Beck and colleagues suggested that receptive vocabulary scores can be used as a proxy for general intelligence, and thus perhaps general intelligence predicts children's success on innovation challenges (Beck et al., 2016) - although it is unclear whether receptive vocabulary score represents true general intelligence. Further, the creativity literature from children (Guignard, Kermarrec, & Tordjman, 2016) and adults (Jauk, Benedek, Dunst, & Neubauer, 2013) offers inconclusive findings for a relationship with intelligence, with much evidence showing both a positive and negative relationship - although the disparate methods of assessing creativity makes drawing firm conclusions difficult (for a review see Batey & Furnham, 2006). That older children perform better on innovation tasks is likely due to maturing cognitive processes such as executive functions, which are responsible for mechanisms such as goal-directed behaviour, cognitive flexibility and inhibitory control (Baddeley, 1996; Carr et al., 2015; Cutting et al., 2011). Aside from intelligence, intrinsic motivation (such as desire for a challenge), more so than extrinsic motivation (such as pay or other incentives), predicted adult innovativeness in workplace settings (Sauermann & Cohen, 2010), indicating that in this case, an intrinsic factor was a bigger driver of innovation than extrinsic factors.

Animal work has also identified various stable, individual-level characteristics which correlate with innovativeness, but some of the evidence is also contradictory. For example, in chimpanzees there is evidence that both younger individuals (Kummer & Goodall, 1985), and adults (Reader & Laland, 2001) are more innovative. Similarly, some studies have found that low ranking and/or poor competitors are more innovative in feeding contexts (Reader & Laland, 2001), and relatedly, that recent energy expenditure positively correlated with chimpanzee tool use and innovation (Gruber et al., 2016). These findings support the 'necessity drives innovation' hypothesis, which states that innovation is a necessary

response to the scarcity or lack of access to resources some individuals face (Fox, van Schaik, Sitompul, & Wright, 2004; Reader & Laland, 2003). However, others studies have found that sheer exposure to innovative opportunities predicts innovation rates in chimpanzees (Koops, Visalberghi, & van Schaik, 2014; Sanz & Morgan, 2013). Such findings are in line with the ‘opportunity drives innovation’ hypothesis (Koops et al., 2014), stating that innovation patterns are shaped by rates of encounter with materials and resources that increase the likelihood of tool use and invention.

These differing results mean there is currently no unifying theory underpinning individual differences in the propensity to innovate. This is potentially a reflection of the various methods applied to assess both individual differences and innovation (Mesoudi et al., 2016). There is a need for more experimental work, particularly with direct cross-species comparisons, to probe the relationship between rank/social status and learning strategies.

2.6 Personality and Social Networks

There are undoubtedly individual differences in the propensity to adopt, and success in using, social and asocial learning. Two specific types of individual differences not yet discussed form the basis of this thesis; personality and social network positions. These factors are intrinsically linked, and research from other fields - most notably adult and other nonhuman animal studies - suggest that these are particularly suitable for exploration in children and chimpanzees (Carter et al., 2014; Rawlings et al., 2017). I now address the literature examining personality and social network positions separately, and as above, owing to the lack of child and chimpanzee literature I include adults and other nonhuman animal work where appropriate.

2.6.1 Personality

Personality refers to the (relatively) stable inter-individual differences in behaviours across time and contexts (Réale, Reader, Sol, McDougall, & Dingemanse, 2007; Smits, Dolan, Vorst, Wicherts, & Timmerman, 2011). Personality influences problem solving and social interactions in many species, including children and chimpanzees (Bouchard & Thomas, 1969; Hopper et al., 2014). Intuitively, therefore, personality should play an important role in the learning strategies individuals adopt. Within the field of cultural evolution, however, the relationship between personality and learning strategies has long been poorly understood. There have, however, been recent empirical and theoretical efforts to integrate personality into the study of individual differences in learning strategies in both humans and animals. Some patterns have emerged from these efforts, though there are also inconsistencies - probably because of the relative infancy of the topic and the multifarious methods to assess personality (Carter, Feeney, Marshall, Cowlshaw, & Heinsohn, 2013; Carter, Marshall, Heinsohn, & Cowlshaw, 2012).

The empirical work within this thesis focusses on ‘The Big Five’ personality traits in children, and six similar traits based on the Big Five, in chimpanzees (Freeman et al., 2013). I therefore focus on this approach to personality in my review. The Big Five is a five-factor model of personality and encompasses five broad domains (openness to experience, agreeableness, conscientiousness, extraversion and neuroticism), each comprising several lower-level facets (McCrae & John, 1992). These have been chosen because they capture a large portion of the variance in personality and are the most widely used measures of personality in humans (Barbaranelli, Caprara, Rabasca, & Pastorelli, 2003; McCrae & John, 1992; Nettle, 2007; Vecchione, Guido, Barbaranelli, & Caprara, 2012), and allow direct comparisons between children and chimpanzees (King, Weiss, & Sisco, 2008; Weiss & King, 2015).

2.6.2 Human personality social information use and social learning

Personality traits begin to stabilise in mid-childhood (Roberts & Delvecchio, 2000). Personality shapes how children solve problems, interact with others, and predicts academic and creative achievement (Batey & Furnham, 2006; Poropat, 2014b). Thus, it seems likely that personality should influence the propensity to adopt specific learning strategies. However, few studies have tested this, and those that have done so have focused on a limited range of personality traits, namely those associated with extraversion, such as the tendency to be sociable, bold, outgoing, active and socially dominant.

The link between extraversion and social information use arises from a very young age; 12- to 15 - month old infants scoring highly on parental ratings of extraversion more faithfully imitated adults during toy-use games than low extraversion scorers (Hilbrink, Sakkalou, Ellis-Davies, Fowler, & Gattis, 2013). Similarly, positive correlations were found between parental ratings of extraversion - but not language development - and the success of judging others as reliable sources of information in three-year olds (Canfield, Saudino, & Ganea, 2015). It has been suggested that the social nature of extraverts may increase social information use through greater motivation to interact with others (Hilbrink et al., 2013). It is also possible that extraverts may be more proficient at judging social environments through having more diverse social experiences and therefore be more practiced at social interaction (Canfield et al., 2015).

Adult research also suggests that characteristics related to extraversion positively influence the use of social information. In an image identification task, adults' social dominance positively predicted reliance on social information (Cook, den Ouden, Heyes, & Cools, 2014). Adults scoring higher in extraversion were also found to have higher brain activity levels (as measured by event related potential) in response

to images of faces compared higher scores of introversion (Fishman, Ng, & Bellugi, 2011). In line with Hilbrink et al. (2013), Fishman and colleagues proposed this may result from extroverts' increased motivation for social stimuli (Fishman et al., 2011). Indeed, extraversion positively predicts adults' social network size (Pollet, Roberts, & Dunbar, 2011; Roberts, Wilson, Fedurek, & Dunbar, 2008), potentially indicating that extraverts are more motivated to establish and maintain social relationships, and subsequently will probably face more diverse social experiences.

There is also some evidence that cultural background influences adult learning strategy adoption (Mesoudi et al., 2014; Toelch et al., 2013). Adults from mainland China used social information more on an artefact-design task than both people from the UK and Chinese immigrants to the UK (Mesoudi et al., 2014). Similarly, adults self-rated as highly collectivist were more likely to use social information on a stock-investment game than those who rated themselves as more individualistic (Toelch et al., 2013). Since some cross-cultural research has indicated that cultural background shapes some personality characteristics (Hofstede & McCrae, 2004), these findings could be taken as further support of a potential personality-learning strategy interaction.

There is a need to explore a wider range of personality characteristics to determine whether other aspects of personality, including both social and non-social traits shape learning strategy use. For example, intuitively agreeableness – the tendency to be kind, cooperative, trusting and prosocial – would lend itself to copying others. There is also evidence that adults scoring highly in neuroticism (the tendency to worry) experience increased anxiety in social situations (Norton, Cox, Hewitt, & McLeod, 1997). How this might map onto the use of social information remains unclear; the topic of personality and learning strategies is ripe for exploration.

2.6.3 Animal personality, social information use and social learning

Animal personality has experienced an unprecedented increase in research over the past decade. As a result, we know a great deal about personality in nonhuman animals, including how personality influences animal learning (Guillette, Baron, Sturdy, & Spetch, 2016), social interactions (Massen & Koski, 2014), and reproductive success and survival (Smith & Blumstein, 2008). In recent years, there has been a particular emphasis on understanding how inter-individual variation in personality corresponds with inter-individual variation in cognition (Altschul, Wallace, Sonnweber, Tomonaga, & Weiss, 2017; Guillette, Naguib, & Griffin, 2017). This has subsequently improved our understanding of how individuals' specific personality traits may influence their problem solving tendencies in a range of species (Hopper et al., 2014; Lermite, Peneaux, & Griffin, 2016; Mesoudi et al., 2016).

As with humans, much of the work investigating the relationship between nonhuman animal personality and learning strategy adoption has focused on a limited range of traits, most of which can be viewed as facets of human extraversion (Nettle, 2006). Two of the mostly widely used axes are boldness-shyness, and relatedly, proactive-reactive personalities. Bolder individuals display more risk-taking behaviours and shyer individuals are more risk-averse. Proactive individuals are more aggressive, bolder, faster environment-samplers and more willing to explore novel environments, while reactive individuals are shyer, risk-averse, less exploratory and aggressive, and slower to sample new environments (Carter, Feeney, et al., 2013).

Studies investigating how these axes influence social learning have yielded mixed evidence. For instance, experiments across various animal species report a positive correlation between boldness and the use of social information in foraging tasks (baboons; Carter et al., 2014; Carter, Tico, & Cowlshaw, 2016; great tits: Marchetti & Drent, 2000; guppies: Trompf & Brown, 2014). Similarly, fast-exploring,

threespined sticklebacks showed greater social information use than slow-explorers on maze tasks (Nomakuchi, Park, & Bell, 2009). Boldness has been linked with attraction to social interactions in nonhuman animals (Grazlano & Ward, 1992; Jolles et al., 2015), which implies that bolder individuals obtain social information through direct social interaction with conspecifics. Moreover, given that traits such as boldness and fast-exploration are analogous to those under the construct of human extraversion, these results can be considered further evidence for a relationship between constructs related to extraversion and social information use.

However, there is also some evidence supporting the opposite relationship. In great tits, proactive individuals foraged more at the spatial periphery of flocks (i.e. away from most individuals) than reactive individuals (Aplin, Farine, Mann, & Sheldon, 2014), while sheep rated as shy were found to have a greater social attraction parameter (i.e. social attraction to conspecifics) (Michelena, Jeanson, Deneubourg, & Sibbald, 2010) and to graze in closer proximity to others (Sibbald, Erhard, McLeod, & Hooper, 2009), compared to bolder sheep. In barnacle geese, Kurvers et al. (2010) found a negative relationship between boldness and social information use; individuals rated as shy were more likely to obtain social information in foraging contexts. Finally, in great tits, highly exploratory females showed less social information use than less-exploratory females (Rosa, Nguyen, & Dubois, 2012). Thus, in these studies, shyer and risk averse individuals were those that were more likely to be exposed to, and in some cases to use, social information. One possible explanation for the contradictory findings is that shyer individuals obtain social information as a function of the tendency to stay close to group members (through increased fear) as opposed to actively applying a strategy to do so. In contrast, bolder individuals do so through increased attraction to social interactions (Kurvers, Prins, et al., 2010).

2.7 Personality, asocial learning and innovation

Asocial problem solving requires different skills than social learning. In particular, creativity and innovation are required to generate appropriate solutions without social information (Bateson & Martin, 2013; Kaufman & Kaufman, 2015). Therefore, the relationship between personality and these characteristics is pertinent. While we know that most children and chimpanzees struggle to solve innovation tasks asocially, we know little about whether personality predicts their success and failure, and their tendency to tackle problems without observing others.

2.7.1 Human personality asocial learning and innovation

To my knowledge, no study has specifically examined the relationship between personality and innovation in children. Early work reported that highly anxious children (a facet of neuroticism) tended to perform worse (were less flexible and more error-prone) on individual test-based cognitive problem solving tasks than less anxious individuals (Marlett & Watson, 1968; Messer, 1970). The authors suggested that anxious individuals' tendency to worry and ruminate negatively impacted cognitive performance (Marlett & Watson, 1968; Messer, 1970). However, it is unclear whether these findings would translate to problem solving in the physical domain.

Much of the adult work comes from studies conducted within workplace settings, suggesting that openness to experience (hereafter openness) is linked to innovation. Employees rated as high in openness are judged as more creative and innovative by employers at work (Baer & Oldham, 2006; Baer, 2010; George & Zhou, 2001). Moreover, adults scoring highly in openness perform particularly well on tests of creativity (see Batey & Furnham, 2006), and openness is associated with groups that are widely-regarded as creative, such as musicians and artists (Feist, 1998) and is positively correlated with performance on divergent thinking tasks (McCrae, 1987). Openness is characterised by being curious,

artistic, imaginative and inventive; characteristics which seem to map on to innovation and creativity, and therefore, asocial problem solving (Griffin & Guez, 2014).

There is also some, albeit tentative, evidence that agreeableness (the tendency to be kind, prosocial, trusting and considerate) – and related traits - are negatively correlated with creativity and thus potentially innovation. For instance, agreeableness is negatively related to lifetime creative achievement and divergent thinking (Batey & Furnham, 2006), while hostility and dishonesty were positively related to both scientific innovation (Feist, 1998) and self-reports of creativity (Silvia, Kaufman, Reiter-Palmon, & Wigert, 2011). However, other studies have found no evidence of a relationship (for reviews see Batey & Furnham, 2006; Silvia et al., 2011) making drawing firm conclusions difficult. Further, as with the work on anxiety and cognitive performance, it is also unclear how the measures of innovation and creativity above would convert to innovation in the physical domain. The constructs of openness and agreeableness have been verified in children (Asendorpf & van Aken, 2003; John, Caspi, Robins, Moffitt, & Stouthamer-Loeber, 1994), offering the potential to test whether children rated high in openness and low in agreeableness are more innovative or more inclined to solve problems asocially.

Other personality traits have also yielded largely mixed results in adults. For instance, introversion (the tendency to be shy and inactive) positively correlated with creative achievement in academic settings (Busse & Mansfield, 1984) and with creative story-writing (Helson, 1977), which suggests that introverted individuals show greater creativity in ‘natural’ contexts. However, extraversion has been found to predict greater divergent thinking scores and the ability to generate novel ideas in laboratory contexts (Chamorro-Premuzic & Reichenbacher, 2008; Furnham & Bachtiar, 2008). Similarly, results in opposite directions have been reported for the relationship between neuroticism and measures of creativity (Archie, Tung, Clark, Altmann, & Alberts, 2014).

Thus, there are numerous studies reporting a relationship between personality traits (as measured by the Big Five) and innovative and creative performance, but the results are often mixed. Several related reasons may underpin the conflicting findings. First, measures of innovation and creativity vary dramatically across studies; the studies outlined above include a range of measures including self-ratings and ratings of others' innovativeness, test performance, business awards and ratings of literacy performance. It is highly likely that the effect personality has on innovation and creativity is heavily influenced by the type of task assessing creativity (Davis, 2009; Silvia et al., 2011). Second, it may be that personality and context interact, meaning external conditions (as well as task type) influence the outcome. Studies have shown that extraversion increases individuals' creative performance when arousal is increased, such as under test conditions (Chamorro-Premuzic & Reichenbacher, 2008), which may imply that arousal increases the propensity to solve problems asocially in some personality types. Similarly, as mentioned, adults who score high in neuroticism experience increased anxiety in social contexts compared with those who score low in neuroticism (Norton et al., 1997), and when self-rating, high-scoring neurotics may be less likely to promote their own creativity (Batey & Furnham, 2006). These factors make it difficult to draw robust conclusions across different measures of innovation and creativity and highlight the importance of considering how personality and context interact to influence learning strategies in different situations and to investigate these questions of directionality.

2.7.2 Animal personality, asocial learning and innovation

The growth of animal personality research has also spurred a mounting interest on the question of whether personality is associated with individual differences in animals' individual problem solving (Hopper et al., 2014; Morand-Ferron et al., 2011). The propensity to innovate can have major ecological and evolutionary benefits (Sol et al., 2005), and thus researchers from a range of disciplines have begun

to investigate which factors, if any, differentiate innovators from non-innovators (Brosnan & Hopper, 2014).

Two of the most widely explored dimensions are within the neophobia (novelty-aversion) and neophilia (affinity to novelty) axis. Empirical and theoretical work have highlighted these dimensions as major predictors of innovation propensity (Brosnan & Hopper, 2014). Across species, neophobia is negatively associated with innovation propensity, and exploration on extractive foraging tasks (spotted hyenas; Benson-Amram & Holekamp, 2012, callitrichids; Day, Coe, Kendal, & Laland, 2003, carib grackles; Overington, Cauchard, Côté, & Lefebvre, 2011, corvids; Stöwe et al., 2006). By being less likely to explore novel situations and objects and less likely to exploit new food types, neophobic individuals face fewer innovation opportunities (Call, 2015). In contrast, neophilic individuals show a greater attraction to novel situations, and thus have a greater propensity to innovate and better performances on innovation tasks. For example, callitrichid monkeys identified as neophilic were quicker to solve, and were more successful overall, on novel puzzle-box tasks (Day et al., 2003), while fast exploring Panamanian bishop fish and black-capped chickadees learned novel foraging tasks quicker than slow-explorers (DePasquale, Wagner, Archard, Ferguson, & Braithwaite, 2014; Guillette, Reddon, Hurd, & Sturdy, 2009). By more frequently encountering and interacting with novel situations and problems, neophilic individuals have more opportunities to learn about these problems and therefore generate innovative solutions to them (Tebbich, Griffin, Peschl, & Sterelny, 2016).

These findings are important for our progress in understanding which individuals are more likely to innovate and which individuals show a lower propensity to do so. However, the manifold methods - arising from several disciplines - used to assess these personality dimensions and innovation (for discussions, see Carter, Feeney, et al., 2013; Carter et al., 2012; Guillette, Naguib, & Griffin, 2017;

Lermite, Peneaux, & Griffin, 2016) provide limited opportunities for within- and cross-species comparisons. To better understand the evolutionary origins of individual differences in learning strategy choices, research adopting species-comparable instruments to investigate personality is needed. Recently, there has been a growing corpus of great ape (particularly chimpanzee) studies developing personality scales comparable with humans' (Freeman et al., 2013; Garai, Weiss, Arnaud, & Furuichi, 2016; Úbeda & Llorente, 2015; Weiss, King, & Murray, 2011). These species-comparable personality measures allow direct comparative investigation of how these traits influence human and nonhuman ape problem solving. To date, just one study has taken this approach; Hopper et al. (2014) used the scale developed by Freeman and colleagues, finding that openness, dominance and reactivity/undependability positively influenced puzzle-box interaction duration in male chimpanzees, offering important but tentative evidence of similarities with human research. Cross-species studies assessing personality and individual solving ability are crucial to build on these initial findings. The aim of this thesis is to extend these recent developments to test whether the Big Five traits in humans and chimpanzees shape the propensity for specific learning strategies.

2.8 Social network positions

Humans show complex group dynamics based on associations with preferred individuals (McPherson, Smith-Lovin, & Cook, 2001). Social network analysis (SNA) is a method to study the structure of societies, involving quantitatively establishing patterns that emerge from social groups based on spatial associations (i.e. proximity between individuals) and interactions (such as play and nominated or observed friendships). Using SNA, researchers can distinguish an individual's role and influence within a group, as well as group-level factors such as group structure and cohesion. SNA has significant potential for investigating learning strategies because social dynamics affect information flow throughout communities (Galef & Laland, 2005) and individuals are likely to acquire social information

from those that they associate with frequently and form strong social bonds with, a form of directed social learning (Coussi-Korbel & Frigaszy, 1995).

Much empirical work has shown that social network topographies are important for the spread of information, skills and behaviours in adults (see Christakis & Fowler, 2010), children (e.g. Kremer & Miguel, 2003) and animals, including chimpanzees (Hobaiter et al., 2014). However, very little work has yet specifically examined how an individual's specific network position might influence individual or social learning propensity (Rawlings et al., 2017). Individual-level measures of network centrality offer the potential to explore this relationship. There are a range of centrality measures, each of which can be used to probe specific questions. Three of the most commonly used in SNA include: 1) degree centrality (hereafter degree), which is the number of ties an individual has to other members (i.e. the number of associations); 2) betweenness centrality (hereafter betweenness), which measures the number of times an individual is the bridge along the shortest paths connecting two other individuals. High scorers in betweenness are those that connect otherwise unconnected group members; and 3) eigenvector centrality (EV), which measures both the connectedness of an individual and the connectedness of their close associations, capturing a more global measure of an individual's influence. An individual would score highly on EV if s/he *and* her/his close ties are well connected within the network.

Here, I present the literature investigating human social network positions and learning strategies. As in the previous sections, owing to the overall lack of studies, I supplement the literature with nonhuman animal work.

2.8.1 Social learning, social information use and social network positions

As children develop their social networks – particularly those at school - become increasingly complex, fluid, and influential (Ladd & Kochenderfer, 1996). The network topography of school classes from as young as seven years predicts classroom engagement (Cappella, Neal, & Sahu, 2012), educational achievement (see Schneider, Ford, & Perez-Felkner, 2010) and inter-individual conflict (Moultapa, Valente, Gallaher, Rohrbach, & Unger, 2004). Social learning by nature relies on social connections; obtaining information socially requires observing or interacting with others or their behavioural products. Not all individuals have equal opportunities for social learning, because group members vary in their rates of social interactions with one another (Krause, James, Franks, & Croft, 2015). Therefore, SNA has the potential to be an extremely productive method to quantify whether an individual's position within their social group impacts their use of social information.

As with personality, individual differences in the positions children hold within their social networks likely plays an important role in their choices of learning strategies, with each child's position influencing the type of social information and learning strategies they witness (Turner & Flynn, 2016). Children are likely to acquire social information from those that they associate with frequently and form strong social bonds with (Flynn & Whiten, 2012), implying that those with fewer social connections probably have fewer opportunities for social learning. Despite advances in methods to analyse social networks, we know little about the relationship between children's individual-level network positions and their use of learning strategies. No study has investigated this relationship directly, although two- to four-year olds rated as more popular by classmates were observed more, and observed others more, when interacting with a tool-use puzzle box (Flynn & Whiten, 2012). Moreover, in this study, theory of mind, sex, and verbal ability did not predict copying. Classroom popularity has been linked with network centrality (the number and strength of social relationships) in eight- to 11-year olds (Farmer &

Farmer, 1996), suggesting that highly central individuals may use social learning and facilitate it in others.

Adults are more likely to acquire behaviours (beneficial or harmful) of their close network contacts than more distant contacts (Centola, 2010; Christakis & Fowler, 2008), highlighting the role of close network ties on individuals' copying behaviours. Even states such as happiness, sleeping patterns and depression are influenced by an individual's network position (Fowler & Christakis, 2008; Mednick, Christakis, & Fowler, 2010; Rosenquist, Fowler, & Christakis, 2011). Central individuals may be susceptible to behavioural contagion because they occupy 'crossroad' positions in networks, with much exposure to others' behaviours (Mednick et al., 2010). This, coupled with humans' strong proclivity for copying others (Flynn et al., 2016; McGuigan, Makinson, & Whiten, 2011) means that central individuals tend to acquire information from others more frequently than less central individuals.

Studies with nonhuman animals also report a link between network centrality and social information use. In captive squirrel monkeys, individuals with higher eigenvector centrality were more likely to acquire a novel foraging behaviour from a seeded conspecific than those with lower eigenvector centrality (Claidière, Messer, Hoppitt, & Whiten, 2013). While this study generated social networks only from observations at the foraging device (and thus may not be fully representative of naturally-occurring social networks), similar findings were found with wild chacma baboons and captive ravens using naturally-occurring proximity data. In baboons, more central individuals (as measured by degree centrality) were more likely to obtain and use social information (food patch locations) than less central individuals (Carter et al., 2016), and ravens with more and stronger connections solved a puzzle-box sooner (via social observations) than those with few connections (Kulahci et al., 2016).

2.8.2 Asocial learning, innovation and social network positions

Despite innovation being fundamental to cultural evolution, currently the field has little knowledge of the social factors that predict individual innovation - particularly from a developmental perspective. Here, as previously, we can be informed by research in business settings and studies with nonhuman animals. These fields have led the way in investigating how individual level social network factors correlate with innovation in the workplace (Rawlings et al., 2017).

As with the use of social information, just one study has investigated the role social network positions play in innovative abilities of children. Seven- to 10 year-old children scoring highly in betweenness centrality were rated as more innovative on an online application design task (Kratzer & Lettl 2008). High betweenness centrality may have facilitated increased informational diversity through interaction with several unconnected children in their network (Kratzer & Lettl 2008). In turn, these children may have synthesised this diverse information and used it to generate novel, innovative ideas.

Similarly, in business settings, adult employees scoring highly in betweenness centrality, and those with many-but-weaker network ties (compared to many strong network ties) are particularly innovative and creative in the workplace (as measured by publications, awards and supervisors' ratings: Baer, 2010; Baer, Evans, Oldham, & Boasso, 2015; Zhou, Shin, Brass, Choi, & Zhang, 2009). Additionally, adolescent and adult 'lead users' – individuals who adopt new products or technologies before the general market – score highly on measures of betweenness centrality (Kratzer, Lettl, Franke, & Gloor, 2016), and are more active in their communities (Franke & Shah, 2003). In line with Kratzer and Lettl (2008), Baer, Evans, Oldham and Boasso (2015) suggested that access to diverse information may drive workplace innovation. Being exposed to multiple unconnected group members also reduces the amount of 'redundant' (repeated) information an individual is likely to receive (Baer et al., 2015). There is also

some evidence that degree centrality positively predicts innovativeness. Lead users also show higher degree values (have more connections) than non-lead users (Franke & Shah, 2003), and recent large scale meta-analyses have found strong correlations between business-level innovation and degree centrality (Aktamov & Zhao, 2014; Wang, Zhao, Li, & Li, 2015). Similar to explanations of betweenness centrality, it has been proposed that having access to many social connections allows innovators to refine and improve innovations via peer feedback (Fleming & Waguespack, 2007) and access to a greater diversity of information than those with fewer network connections (Baer et al., 2015).

Nonhuman animal work provides further evidence that these measures of network centrality are positively associated with individual problem solving. In three paridae species, greater scores of eigenvector and betweenness centrality (based on proximity measures) predicted the discovery and use of new food patches (Aplin, Farine, Morand-Ferron, & Sheldon, 2012), results that directly corroborate the studies found in humans. Similarly, crows that performed better on social and non-social cognitive tasks were involved in more affiliative and aggressive social interactions (which would translate to centrality) with group members (Wascher, 2015). Thus, both of these studies support the notion that greater social interaction correlates with individual problem solving performance, perhaps because greater experience dealing with complex social interactions and dynamics facilitates greater individual problem solving abilities (Wascher, 2015).

2.9 Conclusion

The relative use of social and asocial learning is fundamental to cultural evolution. Asocial learning generates new cultural variants within populations, and social learning facilitates the transmission of these variants throughout groups. This review has highlighted that children and chimpanzees display

both striking similarities and marked differences in their use of specific learning strategies. Similarly, we see that, in both species, there are undoubtedly individual differences in the propensity to use social or asocial information when faced with novel problems to solve. Not all individuals elect for social information, while not all will tackle novel problems asocially. Two particular types of individual differences that warrant further exploration are personality and social network positions. These factors are intrinsically linked, and there is a small but increasing pool of evidence suggesting they may be particularly influential in an individual's tendency to adopt specific learning strategies. The multifarious methods used to assess personality, social network positions, and learning strategy adoption have limited our ability to make direct cross-species comparisons and thus to examine evolutionary based hypotheses of cultural evolution. I aim to build upon the recent development of comparable cross-species personality instruments and advances in social network analytic technology to explore how these factors predict the use of specific learning strategies in human children and chimpanzees. In turn, this may inform our understanding of how new cultures emerge and establish.

The first empirical chapter of this thesis (Chapter 4) draws on sections 2.6.2 and 2.7.1 of the literature review, to investigate the role of personality on children's use of social and asocial information. This will be the first study to assess whether personality - as measured by the Big Five - predicts children's explicit choices of solving problems socially or asocially. In turn, this study will provide an understanding of whether, and how, stable, intrinsic factors contribute to individual differences in children's learning strategy use. The second empirical chapter (Chapter 5), drawing on section 2.8, provides a complimentary study of whether an extrinsic factor - social network positions - predicts children's learning strategy choices. There is little consensus on whether (and how) the social environment shapes children's learning strategy choice, despite the importance social dynamics play in information transmission. By applying social network analysis to assess how individual differences in

network positions predict the use of social or asocial information, this study will provide a much-needed examination of how measures of network centrality (number and strength of social relations) maps on to the propensity to copy or to innovate.

Nonhuman animal personality has experienced a surge of research interest in recent years.

Consequently, an increasing body of work is emphasising the role personality plays in animal cognitive performance. Logistical constraints have meant most studies investigating this relationship rely on personality data collected - often substantially - prior to cognitive testing. Chapter 6 provides the first longitudinal study of nonhuman primate personality assessed using the same personality instrument (based on the Big Five). I evaluate the stability of chimpanzee personality over a 10 year period, providing both the opportunity to compare the results with published work on human personality stability, and allowing an assessment of the validity of using personality data collected at an earlier time point than cognitive testing.

The final empirical chapter (Chapter 7) builds on sections 2.6.3 and 2.7.3 of the literature review by investigating the relationship between chimpanzee personality and learning strategy use. By including personality traits directly comparable to those used with the children, this experiment provides a comparative perspective to Chapter 4. In turn, this study will be informative about whether the same or different underlying personality traits correlate with social and asocial information use across the two most cultural species on the planet (chimpanzees and humans). Cross-species similarities might suggest that parallel individual differences influencing learning strategy use may have been present in the last common ancestor of humans and chimpanzees.

Decades of research within the field of cultural evolution has furnished us with a rich understanding of when, how and why children and chimpanzees copy others, and the similarities and differences across species. However, individual differences in the use of asocial and social learning represents a gap in our knowledge regarding how new cultures emerge and establish. By using directly comparable measures of learning strategies (puzzle-boxes, innovation challenges) and individual differences, this thesis is intended to provide much needed insights pertaining to which individuals are essential for the generation of new cultural variants in populations, and which individuals are crucial for the dissemination of these variants throughout populations.

Chapter 3: General Methods

The following chapter provides a broad outline of the general methods used throughout this thesis. It is not intended to be exhaustive, but to provide a guideline of the overall methodology applied, and some reasoning behind it. Further details regarding all methods are presented within the relevant empirical chapters.

I start by outlining the comparative approach to research and explore its application and value to cultural evolution in particular. I then briefly describe the study participants and subjects (e.g. ages, location), before turning to summarise the apparatus (i.e. puzzle-boxes) used within the empirical studies of this thesis. Next, I explain the measures of individual differences focused on here and the methods used to attain them; personality (children and chimpanzees) and social network data (children). A brief description of the testing procedures follows before I explain the process of obtaining ethical consent for the research conducted. I finish by briefly outlining the approach to statistical analyses conducted throughout this thesis.

3.1 The comparative approach

The overarching methodology of my thesis is a comparative one. Here, the comparative approach involves comparing the behaviours of humans with nonhuman animals to elucidate cross-species similarities and differences. Comparative research has been applied across a diverse range of domains and taxa, including cross-species assessments of communication (Liebal, Müller, & Pika, 2007), working memory (Fagot & De Lillo, 2011), social and nonsocial cognition (Hanus et al., 2011) and personality (King et al., 2008; Weiss, Inoue-Murayama, King, Adams, & Matsuzawa, 2012), and has thus proved fruitful in the quest to understand the evolutionary origins of human cognition. Specific to this thesis, comparative work has been fundamental to refining our knowledge of cultural evolution; as a result of decades of research we now know that culture, which was once deemed a defining feature of humans, is seen in a diverse range of taxa who exhibit behaviours that are culturally determined (for a recent review, see Whiten, Ayala, Feldman, & Laland, 2017).

Chimpanzees, as humans' closest living relative and (arguably) our most culturally closely related species (based on the extensive range of population-specific behaviours they display; Street, Navarrete, Reader, & Laland, 2017; Whiten, 2017a; Whiten et al., 1999), have been the subject of intense research within the field of cultural evolution, providing a rich knowledge base for comparisons with humans (Price et al., 2017; Vale, Flynn, et al., 2017; Vale et al., 2014; Whiten, 2017b; Whiten et al., 2009). Consequently, we know much about the similarities and discrepancies in learning behaviours between humans and chimpanzees. For instance, both species appear to be better equipped to engage in social learning than innovation; children and chimpanzees are capable of acquiring and transmitting novel, complex tool-use behaviours between and within groups (Flynn & Whiten, 2008; Hopper et al., 2007; Hopper, Flynn, Wood, & Whiten, 2010; Whiten et al., 2007), but both species exhibit low success rates with experimentally induced innovation challenges (Beck et al., 2011; Nielsen, 2013; Tennie et al.,

2009). Moreover, both humans and chimpanzees possess a suite of adaptive learning strategies, including preferentially copying others based on success or status, in conditions of uncertainty, or when asocial information is costly to obtain or obsolete (see Price, Wood, & Whiten, 2017). Such strategies allow individuals to offset the risk of potentially maladaptive or outmoded personal information (Kendal et al., 2009) and facilitate within-group homogeneity by influencing the dissemination and preservation of population specific behaviours.

Comparative studies have also revealed key differences in the learning behaviours of children and chimpanzees. Perhaps most notably is the species-differences in the propensity to ‘overimitate’ – the tendency to copy all elements of a demonstration, including actions that are obviously causally unrelated to the outcome. When provided with adult demonstrations on novel puzzle-boxes, children from a variety of cultures show a striking tendency to copy such causally irrelevant actions (Chudek et al., 2016; Frick et al., 2017; Johnston, Holden, & Santos, 2017; Nielsen & Tomaselli, 2010). In contrast, chimpanzees (and other great apes) only copy causally relevant actions and thus do not engage in overimitation (Clay & Tennie, 2017; Horner et al., 2006). Other species-differences have also been noted, including the relative use of personal and social information (Vale, Flynn, et al., 2017; van Leeuwen, Call, et al., 2014), performance on social cognition tasks (Hanus et al., 2011), the proclivity to conform to conspecifics (Haun, Rekers, & Tomasello, 2014) and engage in teaching and prosocial behaviours during problem-solving (Dean et al., 2012). These differences are thought to play key roles in the cultural separation between humans and chimpanzees (Dean et al., 2012; van Leeuwen, Call, et al., 2014).

It is important to note, however, that much of our knowledge stems from indirect comparisons based on studies of children and chimpanzees separately; it is less frequent for studies to incorporate both species

within-studies for direct comparisons (Nielsen & Haun, 2016). This is likely owing to the inherent difficulties of collecting data on multiple species, including access to participants/subjects, and designing and implementing species-comparable tasks and measures (Leavens, Bard, & Hopkins, 2017). However, direct comparisons across species are important to garner a global picture of how and when human psychological mechanisms may have evolved (Nielsen & Haun, 2016). As such, studies involving direct comparisons are essential to fully understand species-specific learning strategy behaviours, and are a powerful method to comprehend the evolution of human culture

This thesis takes a comparative approach by explicitly comparing the learning strategy behaviours of children and chimpanzees on comparable novel tasks and with analogous measures of individual differences. The objective of this thesis was to document cross-species continuity and variation in learning strategy behaviours, and the factors predicting inter- and intra-individual variation in the use of social and asocial information in human children and chimpanzees.

3.2 Participants and subjects

3.2.1 Children

Participants were seven- to 11-year old children from 10 schools in the UK: nine primary schools in the North East of England and one school in the South West of England. In total, 282 children ($M = 9.41$ years, $SD = 1.17$; 136 males) participated. Participants came from four different UK primary school years: Year 3 (seven- to eight-years old, $N = 65$), Year 4 (eight- to nine-years old, $N = 79$), Year 5 (nine- to 10-years old, $N = 71$) and Year 6 (10- to 11-years old, $N = 67$). The first empirical study (Chapter 4) included all participants. The second empirical study (Chapter 5) included a subset of these same participants ($N = 155$, $M = 9.63$ years, $SD = 1.07$; 78 males).

This age range was selected for several reasons. First, the empirical work with children in this thesis was especially informed by two previous studies, both of which investigated younger children. These studies found that the majority of young children explicitly elect for social information over asocial information if the choice is overtly offered (three- and five-year olds; Flynn, Turner, & Giraldeau, 2016), and that while children generally are unlikely to deviate from adult demonstrations of novel apparatus, older children show a greater propensity to do so than younger children (four- to nine-year olds; Carr, Kendal, & Flynn, 2015). Accordingly, a central aim of this thesis was to extrapolate these data to older children (seven- to 11-years old) in order to extend our knowledge of the developmental trajectory of children's use of social and asocial information. This, in turn, would also provide additional data to compare with similar studies with adults (e.g. Mesoudi, 2011). Second, and relatedly, the vast majority of developmental studies within cultural evolution involve young children, typically between the ages of two- to six-years (for recent reviews of the literature of children's learning strategies, see Carr, Kendal, & Flynn, 2016; Price et al., 2016; Wood, Kendal, & Flynn, 2013a and Chapter 2). Rare studies have, however, investigated older children providing much needed insights into the extended developmental trajectory of children's propensity to engage in social learning and innovation. For instance, when given adult demonstrations on puzzle-boxes, even children up to the age of 15 years will faithfully replicate unreliable or irrelevant actions (Carr et al., 2015; Whiten, Allan, et al., 2016). Interestingly, however, if subsequently given multiple attempts to interact with a puzzle-box, older children exhibit a greater willingness to deviate from social information than younger children (Carr et al., 2015). Further work is needed to replicate and build upon these studies with older children to investigate age-related continuation and variation in children's learning strategies.

The third reason for the age range selected, was that a key aim of this thesis was to focus on comparative measures of personality. Recent developments within the field of animal personality have generated

several instruments measuring personality traits comparable to the Big Five in humans (see Chapters 2.6.3 and 6.2 for further details on the development of such instruments). The five-factor model (Big Five) has been widely used, and thus well validated, to study personality in children of the age range of the current thesis (Barbaranelli et al., 2003; John, Caspi, Robins, Moffitt, & Stouthamer-Loeber, 1994; Markey, Markey, & Tinsley, 2004; Poropat, 2014a), but its use is comparatively rare in younger children. The five-factor model has also been shown to correlate with a diverse range of behavioural measures in children of the age range tested within this thesis (Asendorpf & van Aken, 2003; Dennissen, Asendorpf, & Van Aken, 2007; Gjerde & Cardilla, 2009; Luan, Hutteman, Denissen, Asendorpf, & van Aken, 2016) enabling the wider picture within which the results sit to be explored.

There has been a recent acknowledgement that our understanding of cultural evolution, and developmental psychology in general suffers from a lack of diversity in terms of the participant pool studied, (i.e. the vast focus of developmental psychology studies involved participants from WEIRD populations; Western, Industrialised, Educated, Rich and Democratic populations; Henrich, Heine, & Norenzayan, 2010; Nielsen & Haun, 2016; Nielsen, Haun, Kärtner, & Legare, 2017). While the current thesis did not permit investigations of children beyond the UK, the implications and limitations of this approach will be discussed in the General Discussion (Chapter 8).

3.2.2 Chimpanzees

The chimpanzees which were tested within this thesis were housed at the National Centre for Chimpanzee Care (NCCC), Bastrop, Texas, USA. The NCCC is part of the MD Anderson Michale Keeling Center for Comparative Medicine and Research, and overall houses a colony of approximately 125 chimpanzees. Most chimpanzees were captive-born and mother-reared and had been housed at the

facility for several years. Including control subjects, I collected experimental data on 65 adult chimpanzees (29 males).

Testing subjects were 49 chimpanzees ($M = 27.71$ years, $SD = 6.28$; males = 23) comprising six multi-male-multi-female social groups (group size range: six- to 10-chimpanzees). Control subjects were from two groups, both comprising eight individuals ($N = 16$, six males) and the mean age was 23.94 years ($SD = 5.40$). All subjects that participated in the experiments (including control subjects) were housed in hexagonal corrals. The outdoor areas of the corrals measured approximately 3400 square feet and were enriched with a range of climbing frames and nettings, ropes and tunnels. All corrals had several barred and meshed windows around the hexagonal outdoor enclosures through which chimpanzees can interact with experimental apparatus (previous studies taking this approach at the NCCC include Davis, Vale, Schapiro, Lambeth, & Whiten, 2016; Hopper et al., 2014; Price, Lambeth, Schapiro, & Whiten, 2009; Vale et al., 2017; Vale, Davis, Lambeth, Schapiro, & Whiten, 2016; Watson et al., 2017, but see Leavens et al., 2017; and the General Discussion [Chapter 8] for a discussion on the validity of such approaches).

3.3 Puzzle-boxes

Puzzle-boxes (often termed ‘artificial fruits’) are widely used in cultural evolution studies with children (Dean et al., 2012; McGuigan et al., 2017; McGuigan, Whiten, Flynn, & Horner, 2007; Whiten & Flynn, 2010; L. A. Wood et al., 2013a) and nonhuman primates (Dean et al., 2012; Dindo, Thierry, & Whiten, 2008; Gunhold, Whiten, & Bugnyar, 2014; Horner et al., 2010; van de Waal, Claidière, & Whiten, 2013). The basic premise of puzzle-box tasks is that individuals are required to generate solutions to novel puzzles to extract a species-appropriate reward (usually stickers for children or food rewards for nonhuman primates). ‘Two-action’ tasks are among the most frequently used type of puzzle-box,

whereby the puzzle-boxes offer two possible solutions (Figure 3.1). Typically, such solutions involve opening doors in specific directions (for example, left or right, pushing or pulling) to reveal the reward. Studies employing two-action tasks have been particularly influential in investigating the transmission of behavioural variants within and between groups. By introducing specific solutions into specific populations, researchers can ‘seed’ traditions into populations, allowing an investigation of whether different behavioural variants (on the same apparatus) diffuse within different populations. Indeed, when specific techniques are seeded into groups and the subsequent transmission is recorded, children and nonhuman primates copy with enough fidelity to maintain seeded solutions across multiple ‘generations’, even when alternative solutions are readily available (Dindo et al., 2008; Flynn & Whiten, 2008; Horner et al., 2006; Whiten et al., 2007).

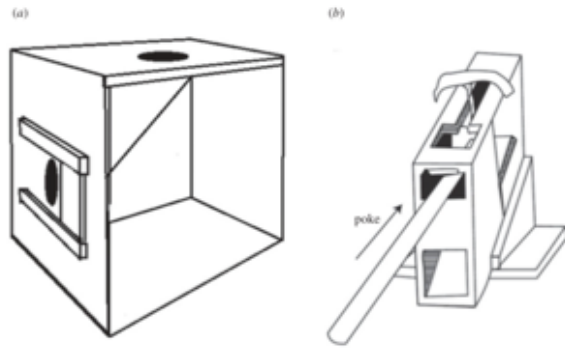

Figure 3.1: Examples of two-action puzzle-boxes, taken from Flynn et al. (2016). The left puzzle-box (slide-door box) requires sliding doors left or right to extract sticker rewards, and the right (panpipes) can be solved by using either a ‘poke’ or ‘lift’ technique using a stick tool.

This thesis aimed to move beyond traditional two-action tasks by using puzzle-boxes with multiple methods of reward extraction. Multi-action tasks afford greater scope of exploration and thus offer a more powerful way to measure phenomena such as copying fidelity and innovative and creative propensity (Auersperg, von Bayern, Gajdon, Huber, & Kacelnik, 2011; Bijvoet-van den Berg & Hoicka, 2014; Carr et al., 2015; McGuigan et al., 2017). Moreover, children and nonhuman animals potentially are more likely to face problems with multiple potential solutions rather than ones with dichotomous

potential solutions. As such, multi-method apparatus potentially offer more ecologically valid measures of the conditions in which problem solving occurs (McGuigan et al., 2017).

3.3.1 Children

In this thesis, the puzzle-box administered to children was the Multi-Method Box (MMB; Figure 3.2), designed by Carr and colleagues at the Department of Psychology, Durham University, and used in Carr, Kendal, and Flynn (2015). The MMB is a plexiglass box, and children were asked to retrieve novel sticker rewards contained within 10 small egg-shaped capsules (one at a time), with three plastic tools available (Figure 3.2). In addition to the reasons mentioned above, the MMB was selected for this thesis as it has been successfully used to document individual differences in copying fidelity in children aged four- to nine-years old (Carr et al., 2015), similar (but younger) to the age range used in this thesis.

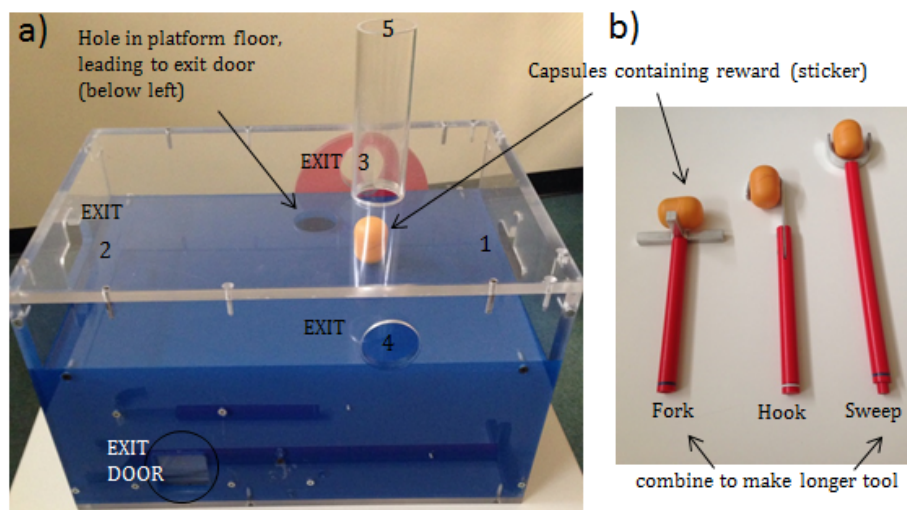

Figure 3.2: *The Multi-Methods Box. A puzzle-box offering multiple ways of extracting sticker rewards contained within capsules (a), and the three tools available (b).*

3.3.2 *Chimpanzees*

Two similar, but distinct puzzle-boxes were administered to chimpanzees and assessed in Chapter 7, Experiment 1 (Lazy-Alpha) and Experiment 2 (Chimpbola)³. The chimpanzee puzzle-boxes were designed in collaboration with the technicians in the Department of Physics, Durham University. Both puzzle-boxes had four possible methods to extract rewards (i.e. were ‘four-action’), by manipulating ‘doors’ in certain directions allowing access to the reward. The Lazy-Alpha puzzle-box comprised a square box which could freely spin around 360 degrees on a vertical axis mounted upon a spinning disc (Figure 3.3B). The Chimpbola was a rectangular box that freely rotated 360 degrees on a horizontal axis mounted on a metal bar (Figure 3.3A). For both boxes, to improve discrimination between the four sides of the box, each door was marked with a different colour and pattern (red, black, blue and green, spots, stripes, full-coloured and chequered patterns - colour-pattern combination varied across Puzzle-boxes A and B; Figure 3.3). Two identical versions of each puzzle-box were made to allow simultaneous presentation to the chimpanzee groups (Figure 3.4), to reduce the issues in data interpretation when dominant individuals monopolise the apparatus (Cronin, Jacobson, Bonnie, & Hopper, 2017; van de Waal, Claidière, & Whiten, 2014). All puzzle-boxes were made from opaque high-density polyethylene and did not require tools to extract the rewards. Further detail on both puzzle-boxes is provided in Chapter 7.

³ The two separate puzzle-boxes used for the chimpanzee empirical work have been termed ‘Lazy-Alpha’ (Experiment 1) and ‘Chimpbola’ (Experiment 2). This is to help distinguish them and reflects their design: The Lazy-Alpha spins on a rotating disc in a manner similar to a ‘Lazy-Susan’ food tray, while the Chimpbola spins on a horizontal bar similar to a Tombola drum.

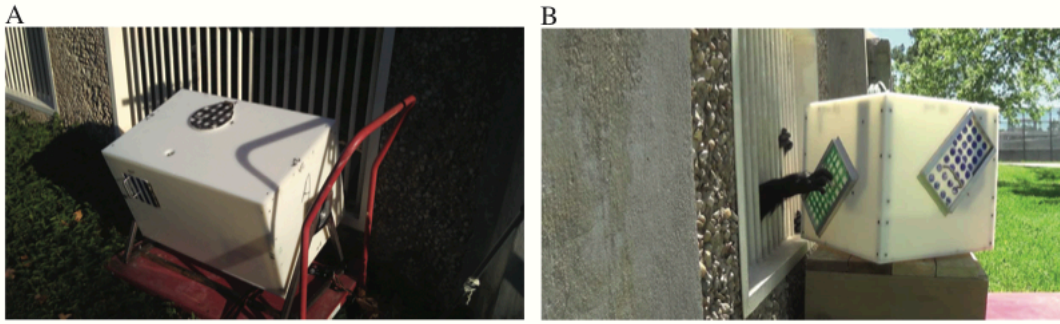

Figure 3.3: *Chimpbola (A) and Lazy-Alpha (B). Both boxes could be turned 360 degrees in any direction on a vertical (Lazy-Alpha) or horizontal axis (Chimpbola) and both were ‘four-action’ designs.*

To my knowledge, none of the chimpanzees at the NCCC have had any experience with either ‘four-action’ puzzle-boxes or with spinning puzzle-boxes. Thus, the design of the boxes in this thesis were entirely novel to subjects yet allowed comparisons with previous studies using similar mechanisms (i.e. sliding doors) with two-action puzzle-boxes, whilst allowing greater scope for exploration (and thus innovation) by individuals. Further, the multi-action design allowed comparison with the MMB administered to the children.

3.3 Personality

The past decade has seen much focus on developing species-comparable measures of personality, particularly with regards to great apes. In humans, the most widely used measure of personality is the five-factor model (the Big Five), which incorporates five broad traits (agreeableness, conscientiousness, extraversion, openness to experience and neuroticism), each of which comprises several sub-facets (John, Caspi, Robins, Moffitt, & Stouthamer-loeber, 1994; McCrae & John, 1992). Comparative researchers have subsequently developed several instruments designed to measure traits comparable to the Big Five in great apes (Freeman et al., 2013; Garai et al., 2016; King & Figueredo, 1997; King et al., 2008). These endeavors have allowed researchers to assess whether personality traits influence performance on cognitive tasks (Altschul et al., 2017; Brosnan et al., 2015; Herrelko, Vick, &

Buchanan-Smith, 2012; Hopper et al., 2014), and in turn, provides the potential for comparisons with human data.

3.3.1 Children

Children's personality was measured by asking parents to complete an abbreviated, 24-item version of the California Child Q-Set (CCQ; Block, 1961, Appendix 4.1), an instrument which measured the Big Five personality traits (agreeableness, conscientiousness, extraversion, openness to experience and neuroticism) in children. An abbreviated version was chosen for practical reasons. Personality scales range from as few as 10 items (Nettle, 2007) to several hundred (Piedmont, 1998). Part of this thesis involved collecting classroom social network data, and for optimal network analysis data is required from at least half of a given school class (or population; Neal, 2011). Thus, by using an abbreviated, 24-item instrument, I aimed to maximise parental consent (by reducing the 'load' administered to parents). The Big Five personality factors have been successfully validated using this instrument (Asendorpf & van Aken, 2003), and it has been shown to correlate with children's long-term behaviour and school achievement (Asendorpf & van Aken, 2003; Dennissen et al., 2007). Further details of the personality measure used for children can be found in Chapter 4.

3.3.2 Chimpanzees

Chimpanzees were rated on a 40-item, seven-point Likert scale instrument measuring six overall traits; agreeableness, dominance, extraversion, methodical, openness and reactivity/undependability (Freeman et al., 2013). This specific scale was selected for several reasons. First, it was established based on data collected in the NCCC chimpanzees (Freeman et al., 2013), including all subjects that participated in the chimpanzee empirical studies of this thesis. During the development process, the instrument was validated with behavioural measures, and has subsequently been successfully used to predict

chimpanzee problem solving (Hopper et al. 2014) and inequity responses (Brosnan et al., 2015) in the past. The scale also significantly correlated with other instruments measuring similar traits in great apes (Freeman et al., 2013). Finally, the fact that it was generated on the same chimpanzees as involved in the present thesis provided the opportunity to assess, for the first time, the long-term stability of chimpanzee personality trait by comparing ratings on the same instrument (Chapter 6). Further details of the personality measure used for chimpanzees can be found in Chapter 6.

3.4 Children's social network data

Children's social network data was obtained through a technique named social cognitive mapping (SCM; Gest, Farmer, Cairns, & Xie, 2003). SCM involves children acting as informants for a class' social network by naming friendship groups from their specific school class. SCM is a particularly useful tool for collecting data on children's social networks, as the triangulation involved in children naming other individuals means it is a more efficient way of gaining network data on the entire classroom than other peer nomination approaches (Neal & Neal, 2013). SCM also avoids potential biases associated with self-reporting of friends, and has been validated in that it positively correlates with observational data of children's affiliative and antagonistic interactions (Gest et al., 2003), as well as teacher ratings and self-report measures (Cappella et al., 2012). Further details about social SCM and the administration procedure can be found in Chapter 5.

3.5 Testing procedures

3.5.1 Children

Children were tested individually away from their classroom settings. This typically involved working in a quiet isolated room in the school (accessible by teachers). Occasionally (three schools), testing involved working in a 'public' area accessible by all pupils (i.e. the school library and gym). In these

cases, it was ensured that participants who were included in the study did not observe others interacting with tasks, by asking teachers to prevent subsequent participants from entering testing areas. Children participated in one testing session, which lasted approximately 20 minutes.

All participants received a reward at the end of testing, regardless of levels of success. Younger children (aged seven- to nine-years old) received a novelty sticker of their choice, and older children (aged 10- to 11-years old) were given the choice between a novelty sticker or novelty eraser of their choice (older children were not aware of the eraser reward until testing had ended). Testing sessions were video-recorded using a Sony Handycam placed in a discreet part of the room, and all sessions were conducted by me alone.

3.5.2 Chimpanzees

Chimpanzees were tested in group settings in their large outdoor enclosures. Puzzle-boxes were presented to barred windows from the outside of the enclosure, allowing chimpanzees to manipulate the apparatus from inside their enclosures (Figure 3.3). Within the experiments, the two identical puzzle-boxes were presented to two windows close in proximity (Figure 3.4). Cherry (baby) tomatoes were used as rewards for chimpanzees, and both types of puzzle-box were presented to the same groups (i.e. all groups that participated in Experiment 1 also participated in Experiment 2). For both the Lazy-Alpha and the Chimpbola, groups received six testing sessions (30- to 45-minutes per session).

Chimpanzees were tested in group settings rather than individually principally because the NCCC had requested that the chimpanzees experience no separations during testing. This was to meet the facility's aim of reducing the overall level of stress the chimpanzees experience.



Figure 3.4: *An example of the experimental setup for chimpanzee experiments.*

Testing sessions were recorded with Sony Handycams, with two researchers (myself and a researcher based at the NCCC; one per puzzle-box) narrating live the identities of individuals interacting with the apparatus, all individuals within 5m of the puzzle-box and all individuals directly observing conspecifics interacting with the puzzle-box.

3.6 Ethical approval and consent

3.6.1 Children

Ethical approval for the collection of child data was approved by the Department of Anthropology Ethics Committee, Durham University. Within the application for ethical approval, details were provided about the purpose of the studies, the experimental procedures and data collection involved, and the type of consent obtained from schools and parents/guardians. Prior to any experimental testing, all schools were contacted and agreed in writing for the study to be conducted. For parental/guardian consent, an ‘opt-in’ approach was used, such that parents/guardians were required to approve their child(ren)’s participation via a written signature (an example of the parental/guardian consent form is given in Appendix 3.1). For all participants, parental/guardian consent was obtained at least one day

prior to testing, and children gave verbal consent themselves immediately before testing. I administered parental/guardian consent forms and personality questionnaires to schools, who distributed and received the forms and questionnaires to, and from, parents/guardians.

All parents/guardians were informed that; a) they could elect for their child's session not to be video recorded (one participant, wherein live coding was conducted), b) they could elect to view the video footage of the testing session (one participant), c) they could elect to not allow for the video footage of their child's testing session to be presented in academic settings such as conferences (no participants), d) they were free to withdraw their child from the study at any point (no participants) and e) that all data was kept strictly confidential and that children's identities would be replaced with anonymous codes after testing had ceased. All children were informed, a) that participation was entirely voluntary and b) that they could withdraw at any time (no participants). After testing in a given school class was completed, teachers were asked to complete personality questionnaires for a random subset of the children who participated from their class (approximately half of participants from a class, depending on the number of children tested). This was in order to validate the personality questionnaire answers provided by parents. Although this was voluntary, no teacher refused.

3.6.2 Chimpanzees

The NCCC is fully accredited by the Association for Assessment and Accreditation of Laboratory Animal Care-International (AAALAC-I). No food or water deprivation was used during this project and subjects' participation was entirely voluntary and involved no separation of individuals. The project was approved by the Animal Welfare Ethical Review Board (AWERB), Durham University, and the Institutional Animal Care and Use Committee of The University of Texas MD Anderson Cancer Center. All individual testing sessions were also approved on the day of testing by carestaff at the NCCC, and

the majority of sessions were supervised by a member of staff trained in chimpanzee behavioural research. In addition, puzzle-boxes have been used as a form of environmental enrichment, and are viewed to have a positive effect on chimpanzee welfare (Clark, 2017).

3.7 Statistical Analysis

Statistical analyses were conducted on IBM SPSS and UCINET (Borgatti, Everett, & Freeman, 2002). Generally, ordinary least squares (OLS) multiple regression analyses were used when appropriate for the main analyses questions. Multiple regressions allow the assessment of the relative influence of several independent variables on a dependent variable, and thus were appropriate to assess the influence of multiple measurements of individual differences on learning strategy adoption. Within the thesis, null hypothesis testing was conducted where the alpha level was set at 0.05. In recognition of concerns arising from relying on relatively arbitrary p-values, effect sizes of models (R^2 values in regression models) were provided within the main text or appendices.

Although analyses models were generally designed to reduce the number of predictor variables as far as possible, as the within-chapter analyses throughout this thesis often incorporated several distinct regressions models, to control for familywise errors arising from multiple comparisons I used a Benjamini-Hochberg false discovery rate control (Storey, 2002). For each ‘family’ of tests I calculated the expected proportion of false positives (erroneous rejection of null hypotheses) from the discoveries. FDR ‘families’ were selected based on the lines of analyses they investigated, such that if, for example a set of analyses were examining children’s social learning behaviours, this was considered a ‘family’. Equally, a set of analyses examining children’s asocial learning behaviours was considered a separate ‘family’, and so on. Within each chapter, descriptions and examples of the FDR families are provided.

There is no established rate at which to set the false discovery rate, and set rates can vary from 5%-30% (Cole et al., 2014; García-Arenzana et al., 2014; McDonald, 2009). Throughout this thesis, I use a false discovery rate of 10% (Higdon, van Belle, & Kolker, 2008). However, while the application of Benjamini-Hochberg FDR controls for familywise error, it has been noted that the application of false discovery rates can produce inaccurate results (e.g., mask significant findings, especially when using a relatively low number of tests [Higdon et al., 2008; McDonald, 2009; Pike, 2011]). If such instances occurred during analyses, I reported the significant findings and that the FDR considered the test result to be non-significant, but as suggested by others (Higdon et al., 2008; McDonald, 2009; Pike, 2011), these results were treated with greater caution than other significant results and discussed such that they indicate potential findings (for an example of this approach, see Hopper et al., 2014).

Finally, throughout the thesis, tests of normality and meeting of the assumptions were assessed using the appropriate measures (for example, in multiple regressions, tests of linearity, homoscedasticity and multicollinearity; for an example of an acceptable diagnostic plot, see Figure 3.5. For brevity, unless reported otherwise, all tests of normality were correct, as were tests of meeting appropriate assumptions.

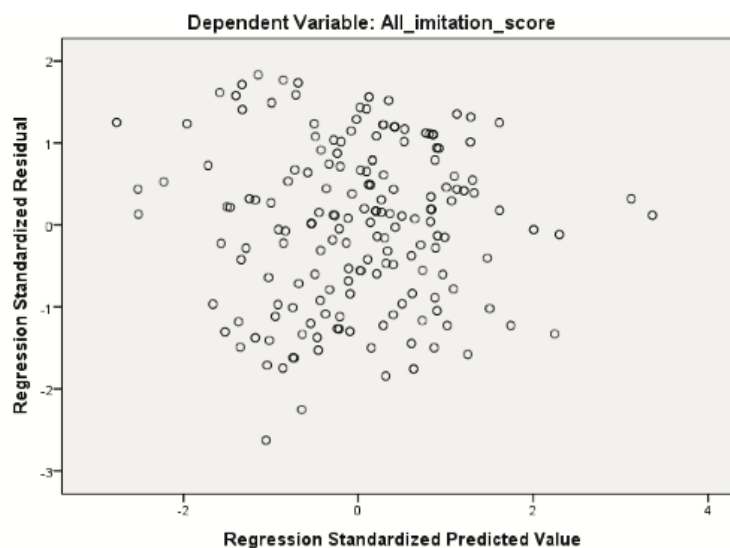

Figure 3.5: An example of an acceptable diagnostic plot for multiple regressions. This displays a plot of standardized residuals with standardized predicted values.

3.8 Conclusion

Overall, the methodological approach here was driven by the potential to provide new insights for the field of cultural evolution. Specifically, several new pathways were pursued. By examining children's and chimpanzees' behaviours on comparable, multi-action puzzle-boxes, this thesis aimed to move beyond the traditionally used two-action tasks to assess the cross-species similarities and differences in learning strategy use on more ecologically valid measures of problem solving. Further, it is hoped that incorporating species-comparable measures of individual differences will afford new insights into whether the same or different factors shape the use of social and asocial information in children and chimpanzees. Finally, by including seven- to 11-year old children and modern social network analysis techniques, this thesis aimed to provide much needed insights both into the extended developmental trajectory of children's learning strategy use, and to shed new light to how the social environment shapes children's learning strategies.

Chapter 4: The role of personality on children's copying and innovation propensities: Conscientiousness, agreeableness and openness matter

Abstract

When faced with novel problems to solve, children can copy the actions of others, modify previously observed behaviours of others or attempt to generate solutions asocially by inventing new behaviours. Currently, little is known about what differentiates those that prefer to copy others from those who innovate. This study examined whether, when faced with a novel problem, personality influences children's propensity to observe others or generate solutions individually. In total, 282 seven- to 11-year olds were presented with a novel, multi-methods tool-use puzzle-box task. All participants were asked by an experimenter "Would you like to have a go yourself, or would you like me to have a go first?" For those that elected for a demonstration, an experimenter performed the same technique four times. Then each child had ten attempts at retrieving rewards from the box. All participants were also presented with an innovation challenge known to be difficult for young children (the Hook Task) and a measure of divergent thinking (the Alternate Uses Task). Personality ratings were obtained through parental and teacher ratings of the Big Five personality traits.

Overall, the majority of children elected for social demonstrations, but the tendency to do so decreased with age. Sex differences were also evident, with males more likely than females to elect for no demonstrations. Conscientiousness predicted the propensity to elect for no demonstrations, while agreeableness predicted the propensity to elect for demonstrations. Further, of those that elected for demonstrations, parental ratings of openness to experience predicted the propensity to deviate from the observed method. Children who elected for no demonstrations were also more likely than those who

opted for social information to both manufacture a tool on the Hook Task, and generated more overall, and more novel, responses for the Alternate Uses task.

Thus, these results show that personality predicts the propensity to elect to observe others or to 'go it alone', and indeed whether they deviate from observed behaviours. Further, to my knowledge, these findings provide the first evidence of a relationship between children's explicit learning strategy choice and their performance on measures of innovative and creative ability. Thus, this study sheds light on what may differentiate individual problem solvers from those that look to others.

4.1 Introduction

The cultural diversity of humans is unparalleled across the animal kingdom; this diversity is maintained through a combination of innovation and social learning (Legare, 2017). Innovation enables adaption to new environmental challenges and modification and improvements of existing cultural repertoires.

Social learning affords faithful transmission of such innovations, promoting population-specific technology, behaviours and skillsets. As such, social learning and innovation are the two fundamentals of human culture (Legare & Nielsen, 2015). Our cultural diversity means children regularly encounter new problems to solve that were not faced by previous generations. Children must decide whether to solve these problems through social learning (information acquired from others) or asocial learning (individual innovation). Each strategy has associated costs and benefits; social learning facilitates rapid, low-cost attainment of skills and behaviours, but social information can be unreliable or outdated.

Asocial learning promotes direct, and thus reliable, information acquisition but can be a costly and time-consuming process (Kendal et al., 2009). Despite this, it has been noted (Carter et al., 2014; Mesoudi, 2017; Mesoudi et al., 2016; Rawlings et al., 2017) that individual differences in the propensity to engage in innovation and social learning remains largely overlooked.

Children are prolific social learners, capable of acquiring and maintaining complex information from others (Berl & Hewlett, 2015; Price et al., 2017; Want & Harris, 2002; L. A. Wood et al., 2013a), and show an attraction to social information from birth (Meltzoff & Moore, 1989). In our complex, tool rich, world readily acquiring information from others affords rapid acquisition of complex skills and behaviours with relatively low cognitive load (Legare & Nielsen, 2015; Nielsen, 2013). Copying others also allows children to integrate into their social environment by acquiring the conventions of their peer groups, often resulting in maintenance of within group homogeneity (Over & Carpenter, 2012; Schleihauf et al., 2018).

Childhood also offers an environment rich in opportunities for exploration, invention and play, which in turn allows children to individually learn novel object affordances and develop creative skills (Bateson, 2014; Pellegrini & Smith, 2005; Pellegrini, Dupuis, & Smith, 2007). Despite this, individually innovating (innovation-by invention; Carr, Kendal, & Flynn, 2016) solutions to experimentally induced problems poses a strikingly difficult challenge for children. Studies that involve presenting children with tool-use and tool-manufacture based innovation challenges show that the majority of young (under eight years) children fail such tasks, including those requiring manipulation of tools (Beck et al., 2011; Neldner, Mushin, & Nielsen, 2017; Nielsen et al., 2014; Tennie et al., 2009), and decanting water to obtain an out of reach reward (Hanus et al., 2011; Nielsen, 2013). The fact that children readily solve such tasks when given a demonstration (Beck et al., 2011; Nielsen, 2013) both emphasises their exceptional social learning abilities and indicates that their asocial struggles cannot be explained by a lack of dexterity to perform the solutions. Instead, young children probably lack the cognitive flexibility to derive a novel solution (Carr et al., 2015), and have a tendency to fixate on previously learned uses of objects (German & Defeyter, 2000); both of which impede their capacity for innovation (for a fuller explanation of this, which current space precludes, see Beck, Williams, Cutting, Apperly, & Chappell, 2016; Carr et al., 2016).

Given the contrast in children's social learning and innovative abilities, it is not surprising that they show a preference for social information when it is available. When presented with novel puzzle-boxes, approximately 75% of three- and five-year olds elected to observe demonstrations first rather than attempting to solve the apparatus individually, regardless of task difficulty (Flynn et al., 2016). Thus, when presented with novel challenges, most children seek social information before attempting to solve the challenge themselves. Similarly, children are reluctant to deviate from social information. Across a

wide age range (three- to 15-years), children remain faithful to witnessed behaviours, even if they are palpably unreliable or irrelevant (Carr et al., 2015; McGuigan et al., 2007; Whiten, Allan, et al., 2016). For instance, in the study by Carr et al. (2015), four- to nine-year old children were presented with a novel, multi-methods puzzle-box and received social demonstrations of varying efficacy. Children's overwhelming strategy was to copy the demonstrated method, despite half of participants witnessing the demonstrator repeatedly fail to extract a reward. This proclivity for observing and copying others over learning asocially is also likely to restrict children's capacity for innovation (Flynn et al., 2016).

It remains unclear, however, which factors differentiate the minority that are willing to tackle novel problems asocially from the majority that prefer to use social information (Carr et al., 2016; Flynn et al., 2016; Rawlings et al., 2017). This is important, because understanding whether there are stable, individual-level characteristics distinguishing those that copy from those that innovate, would provide a key insight regarding how new cultures emerge (through innovators) and establish (through social learners, Legare & Nielsen, 2015).

There are a range of factors that could underlie children's use of specific learning strategies. For instance, older children perform better on innovation challenges and are more likely to deviate from social information than younger children (Beck et al., 2011; Carr et al., 2015), and there is evidence of cross-cultural differences in children's imitative fidelity (Clegg & Legare, 2016). However, we currently know little about whether *intrinsic* factors predict children's learning strategy choices. Recent work has begun to indicate that personality may be an important contributing factor to individual differences in the use of social and asocial information (Carter et al., 2014; Rawlings et al., 2017).

Personality refers to stable, inter-individual differences in thought, behaviour and emotion across time and situations (Smits et al., 2011). The most widely used measure of personality in humans is the five-factor model, commonly termed the 'Big Five' (Furnham & Bachtiar, 2008; McCrae & John, 1992; Nettle, 2007). The Big Five incorporates five broad traits (agreeableness, conscientiousness, extraversion, openness to experience and neuroticism), each of which comprises several sub-facets. The Big Five are well established in children (Asendorpf & van Aken, 2003; John, Caspi, Robins, Moffitt, & Stouthamer-loeber, 1994; Luan et al., 2016; Markey et al., 2004) and correlate with children's social interactions, cognitive performance, academic achievement and problem solving (Asendorpf & van Aken, 2003; Barbaranelli et al., 2003; Poropat, 2009). Thus, intuitively personality should be related to children's learning strategy choices.

Relatively few studies have specifically examined the relationship between personality and social information use in children. Of those that have, most have focussed on extraversion, which appears to be a key personality dimension in the tendency to use social information. For instance, parental ratings of extraversion were positively related to both 12- to 15-month old children's tendency to copy in a game-playing context (Hilbrink et al., 2013), and three-year olds' ability to judge others as reliable sources of information (Canfield et al., 2015). Extraversion largely reflects inter-personal characteristics; highly extraverted individuals are sociable, bold, dominant and outgoing. As such, extraverted individuals are more attracted to social contexts (Feiler & Kleinbaum, 2015; Fishman et al., 2011) and have more experience with them than introverted individuals, allowing them to better judge others as sources of social information (Canfield et al., 2015).

Innovation requires a different skillset to copying others. In particular creativity, inventiveness, and the capacity to generate and implement new behaviours and solutions are needed (Bateson, 2014). Of the

Big Five, openness to experience – being curious, imaginative, artistic and inventive – is most frequently linked with innovativeness and creativity. Openness to experience predicts workplace innovation (as measured by awards and supervisor ratings, Baer, 2012; Laursen & Salter, 2006), and performance on divergent thinking tests - measuring the ability to generate multiple, novel ideas (Chamorro-Premuzic & Reichenbacher, 2008). Openness to experience is also highly correlated with intellect (Aitken-Harris, 2004), and there is tentative evidence to suggest that children with higher general intelligence are more likely to solve innovation challenges (Beck et al., 2016). Thus, it is possible that children high in openness to experience may be more willing and/or able to solve novel problems asocially than children lower in openness to experience.

These studies provide provisional evidence that individual variation in personality correlates with individual variation in the propensity to engage in social learning and innovation. However, there is very little knowledge beyond the traits of extraversion and openness to experience (Rawlings et al., 2017), and thus it is only possible to speculate about how other traits might interact with learning strategies. For instance, agreeableness denotes being kind, prosocial, trusting empathetic and cooperative; traits that seemingly lend themselves more to social learning than innovation. Social learning is facilitated by positive relationships between learner and demonstrator (Coussi-Korbel & Fragaszy, 1995) and agreeableness (and extraversion) is positively related to peer friendship and acceptance in children (Jensen-Campbell et al., 2002) perhaps suggesting highly agreeable individuals would have greater opportunities for observing others (Flynn & Whiten, 2012).

The overarching aim of this study is to examine the relationship between children's personality and their propensity to elect for using, social and asocial information (and their success) when faced with a novel problem. Combining facets of two previous studies, seven- to 11-year old children were presented with

a novel, multi-methods puzzle-box (as used in Carr et al., 2015), and were offered the choice of attempting to solve the task themselves, or to witness a demonstration first (as in Flynn et al., 2016). This age range was chosen in order to expand upon the age range used in these two studies (four- to nine-years old; Carr et al., 2015; three- and five- years; Flynn et al., 2016). To further assess the relationship between personality, learning strategies and innovation, participants were also presented with a tool-based innovation challenge known to be difficult for young children (the Hook Task, Beck et al., 2011) and a divergent thinking task (Alternate Uses task, Guilford, 1967). These two additional tasks allowed investigations of whether there were differences in performance in the ability to independently manufacture appropriate tools (the Hook Task) and the ability to generate novel ideas (Alternate Uses), between children who elect to solve a puzzle-box asocially and those who elect for social information first.

Based on previous empirical studies investigating the role of personality and social information use and innovation, in children and adults I had three main predictions:

1. Most children will elect for a social demonstration over attempting the puzzle-box asocially (Flynn et al., 2016; Wood et al., 2013a).
2. Age will be related to the tendency to innovate. Specifically:
 - 2a. Older children would be more likely to attempt the puzzle-box asocially than younger children (Beck et al. 2011; Flynn et al. 2016) and:
 - 2b. Older children would be more likely to deviate from social demonstrations than younger children (Carr et al. 2016).
3. Extraversion and openness will be related to children's learning strategies. Specifically:
 - 3a. Extraversion would positively predict the use of social information (Rawlings et al. 2016; Hilbrink et al. 2013).

3b. Openness to experience would be positively related to innovation (Rawlings et al. 2016; Baer et al. 2014).

I made no specific predictions about the relationship between learning strategy choice and the other three personality traits (agreeableness, conscientiousness and neuroticism). I also made no specific predictions about the relationship between performance on the Hook and Alternate Uses tasks and learning strategy choice. The relationship between age, sex and personality ratings (and their interactions) will not be presented, as they are not within the focus of the theoretically driven investigation.

4.2 Methods

4.2.1 Participants

Two hundred and eighty-two seven- to 11-year old children ($M = 9.41$ years, $SD = 1.17$; 136 males) participated. Children were recruited from 10 schools across the North East of England (with one school from the South West of England). Participants came from four different UK school years: Year 3 (seven- to eight-years old, $N = 65$), Year 4 (eight- to nine-years old, $N = 79$), Year 5 (nine- to 10-years old, $N = 71$) and Year 6 (10- to 11-years old, $N = 67$). The mean class size was 26 children (range: 15-35 per class). Parental consent was obtained for all participants before study participation (see Chapter 3.6 for details of parental consent and ethical approval).

4.2.2 Battery of Tasks

4.2.2.1 Personality Instrument

Personality was measured by asking parents to complete an abbreviated version of the California Child Q-Set (CCQ; Block, 1961, Appendix 4.1), an instrument which measured the Big Five personality traits

(agreeableness, conscientiousness, extraversion, openness to experience and neuroticism) in children. The abbreviated version, created by Asendorpf and Van Aken (2003), is a 24-item questionnaire, comprising statements with which the parents/guardian indicate how characteristic they are of their child on a five-point scale. An example statement is 'I see my child as someone who is helpful and cooperative', where the parent would indicate whether they disagreed strongly (1) ranging to agreeing strongly (5). The Big Five personality factors have been successfully validated using this instrument (Asendorpf & van Aken, 2003), and it has been shown to correlate with children's long-term behaviour and school achievement (Asendorpf & van Aken, 2003; Dennissen et al., 2007). Personality questionnaires were distributed to parents and subsequently collected from parents by school teachers. For validity purposes, for 51% ($N = 144$) of participants teachers were also asked to complete the abbreviated CCQ.

4.2.3 Experimental Tasks

Children were presented with three tasks; the multi-method puzzle-box, the Alternate Uses Task and the Hook Task. Participants were tested individually, in a quiet area away from other classmates. Upon arrival, I introduced myself and explained that we were going to play some games and obtained verbal consent for participation from the children, before administering the battery of tasks. The order of task presentation was randomised across all participants. All task interactions were video recorded with a camcorder (Sony Handycam) discretely placed in the room.

4.2.3.1 Multi-Methods Box

A novel puzzle-box, named the Multi-Method Box (MMB; Carr, Kendal, & Flynn, 2015) was presented to children (see Figure 4.1a). The overall aim of the MMB was for children to retrieve novel sticker rewards contained within 10 small egg-shaped capsules (one at a time). The MMB comprised two levels

separated by an opaque floor. The top level contained an entry chute to bait the task with the reward capsule, along with four other potential entry and exit points to obtain the reward. One of the entrance points required turning a red dial to gain access. Participants could retrieve the reward by using one of three plastic tools (hook, sweep and fork, Figure 4.1b) to manipulate the capsule through the entrance/exit points at the upper level and retrieve it. The specific tools only fitted into certain access points (entrances) and were long enough only to reach (and manipulate) the capsule from certain access points. Additionally, the sweep and fork tools could be combined for a longer reach. In addition to the entrance/exit holes on the side of the box, there was a hole in the opaque floor (exit hole in Figure 4.1a). If participants manipulated the capsule to this hole it dropped to a lower opaque level of the MMB via a hidden slope where it remained behind a blue door to be retrieved by the experimenter who then added a sticker to the participant's pile of stickers. Thus, the MMB was a reward-baited box with multiple modes of tool entry and reward extraction.

To reduce experimenter and any potential model biases, participants were told that the box belonged to a friend. For instance, it is possible that if children presumed I was the owner of the box, they may defer because I must be an expert, or for normative reasons. It was demonstrated that the capsules contained stickers, and then explained that when a single capsule is entered into the MMB via the entry chute, the goal was to try and get it out in any way they liked. Participants were also told that there were 10 capsules in total and the aim was to see how many they could get out, and that they could make a sticker pile. Following this, the experimenter said "Would you like to have a go yourself or would you like me to have a go first?". If the participant asked for a demonstration, they received a social demonstration, and if they asked to have a go themselves, they received no social information.

For social demonstrations, the experimenter demonstrated a single predetermined technique four times, where the fork tool was inserted via a specific entrance point (entrance one on Figure 4.1a) and the capsule was manipulated into the hole in the opaque floor (exit in Figure 4.1a). Only one of the four demonstrations (25% in total) was successful, which was achieved by using a discrete wireless remote control that locked/unlocked the exit door at the lower level, so the reward could/could not be obtained. Given that previous work (Carr et al., 2015) has shown that even in the face of repeated unsuccessful adult demonstrations on the MMB children remain faithful to witnessed methods, a low efficacy demonstration rate (25%) was used to encourage subsequent exploration in participants. All social demonstrations were delivered to all participants in the same order, where the final attempt was successful after three unsuccessful attempts. After the social demonstration (if applicable), participants were told, ‘Now it’s your turn to have 10 goes to get the eggs out and you can make a sticker pile with the ones you get out. You can do anything you like’. In order to match the social information, the exit door remained locked for participants’ first three attempts, regardless of success or methods used. Those who elected for no social demonstrations were told “You can have 10 goes to get the eggs out and can make a sticker pile with the ones you get out. You can do anything you like”. There was no time limit given to participants, and at the end of the task, all children exchanged their sticker pile for a large sticker.

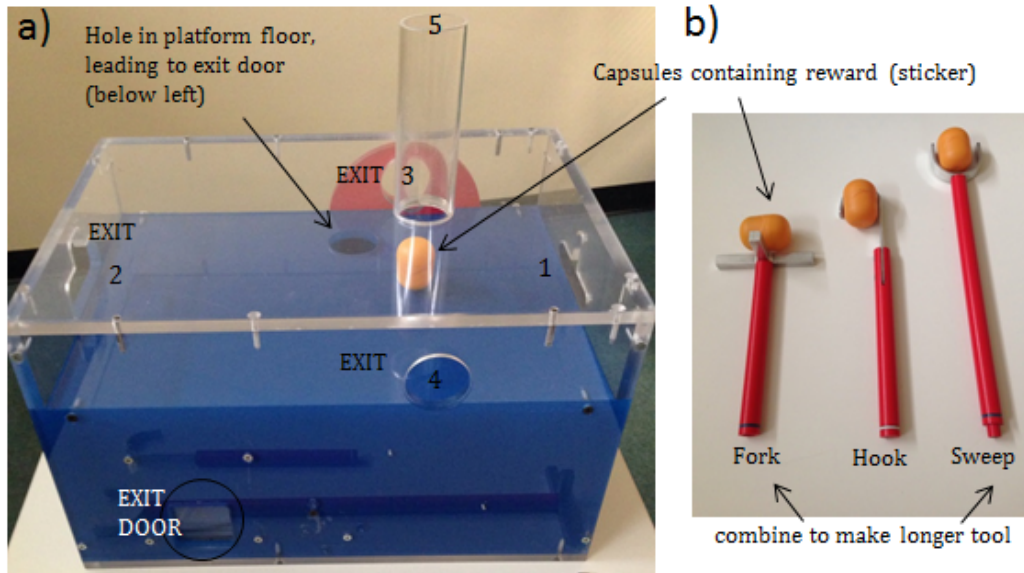

Figure 4.1: *The Multi-Methods Box. A puzzle-box offering multiple ways of extracting sticker rewards contained within capsules (a), and the three tools available (b).*

4.2.3.2 MMB Coding

All attempts were coded to score the methods used and success/failure to retrieve a reward. An attempt was defined as when a participant inserted a tool into the MMB with the seeming purposeful intention (regardless of success or not) of making contact with the capsule and ended when the tool was removed (Carr et al. 2015). Purposeful intention was deemed as when a participant’s gaze and head orientation was directed towards the task, while interacting with the tools in an attempt to retrieve the capsule.

There were some cases involving multiple actions, which were counted as one attempt. If, for example, a participant used a tool to push the capsule towards an exit with one tool, with the intention of making it easier to extract from a different entrance point with a different tool, this was considered as part of the same attempt. In line with Carr et al. (2015), the following MMB behaviours were coded:

All participants

- Whether participants elected for social demonstrations or not (0 coded as elected for demonstrations, 1 coded as no demonstrations).
- The number of successful attempts (max. 10).
- The number of different tools used across all attempts, controlling for their choice of a demonstration or not (max. 4).
- The number of different entrances used across all attempts, controlling for their choice of a demonstration or not (max. 5).
- The number of different exits used across all attempts, controlling for their choice of demonstration or not (max. 6).

Children who elected for demonstrations only

- The number of exact imitations across all attempts; the exact technique (i.e. same tool, entrance and exit) matched to the demonstration (max. 10).
- The number of exit innovations across all attempts; where a different exit than the demonstration was used (max. 10).
- The number of tool innovations across all attempts; where a different tool than the demonstration was used (max. 10).
- The number of entrance innovations across all attempts; where a different entrance than the demonstration was used (max. 10).
- A composite 'deviation' score; across all attempts the total number of tool, entrance and exit deviations from the observed method (max. 30).

Children who did not elect for demonstrations only

- The number of different tools used across all attempts (max. 4).
- The number of different entrances used across all attempts (max. 5).

- The number of different exits used across all attempts (max. 6).
- A composite ‘novelty’ score; the total number of different tools, entrances and exits used across all attempts (max. 15).
- The number of repetitions; the total number of times, across all attempts, that an individual repeated a previously used method exactly (max. 9).

4.2.3.3 The Alternate Uses Test

The Alternate Uses Test (Guilford, 1967) is a measure of divergent thinking, requiring the participant to list potential uses for an everyday object. Participants were presented with a paperclip and the experimenter said “Here is a paperclip. I want you to think of and tell me all the things a paperclip can be used for, all the things you can do with a paperclip”. No time limit was given for responses. The task ended when children stated and confirmed that they could not think of any more uses for the paperclip. Responses had to be deemed suitable to be scored. For example, an answer of ‘bending’ would not qualify unless a more detailed description was provided (i.e. what the paperclip could be bent into).

Scores of fluency and originality were calculated. Fluency simply denotes the total number of responses given. Originality reflects the rarity of responses compared to other participants’ responses. Responses given by 2-5% of participants were scored one point and responses given by 1% or less were assigned two points. Responses given by over 5% of participants were scored 0.

4.2.3.4 The Hook Task

The Hook Task (Beck et al., 2011) is an innovation challenge. Participants were presented with a transparent tube containing an out-of-reach small bucket holding a sticker. Participants were provided with a straight pipe cleaner and a 15 centimetre (cm) piece of string (a distractor item). To extract the

sticker, participants were required to manipulate the pipe cleaner into a hook shape and lift the bucket, by its handle, out of the tube (see Figure 4.2).



Figure 4.2: *The Hook Task apparatus, with the distractor item piece of string (white) and pipe cleaner (black). Figure taken from Cutting, Apperly, Chappell, & Beck (2014).*

Upon presentation of the Hook Task, the experimenter said “Can you see the sticker inside of this tube? I want you to see if you can get it out”. Participants were given three minutes to solve the task. If participants failed to solve it by then the task was terminated. Successful attempts (retrieving the reward) were scored as 1, and failures as 0, and the latency to succeed was recorded. If participants failed to extract the sticker after three minutes, a score of 180 seconds (s) was given. As previous work has shown that around eight years most children succeed with this task (Beck et al., 2011), the specific technique used to retrieve the sticker was also of interest and thus recorded. All children received a sticker irrespective of success or failure.

4.2.4 Statistical analyses

All of the different tasks were analysed in three different test classifications: all participants, those who elected for demonstrations and those who did not elect for demonstrations. Regression analyses were used (binary logistic and multiple) to assess whether personality predicted learning strategy choice and

subsequent performance with each task. Finally, diagnostic inspections suggested no violations of model assumptions (heteroscedasticity, multicollinearity and so on).

A binary logistic regression model examined whether personality predicted the propensity to elect for social demonstrations of the MMB or not (demonstrations versus no demonstrations). Multiple regressions were used to examine the coded variables listed above. In all models, age (years and months), sex (male coded as 1, female coded as 2) and mean ratings on each of the five personality traits were entered as predictor variables. For all regression models computed there was no evidence of multicollinearity (all VIFs < 2.0).

To control for familywise errors arising from multiple comparisons I used a false discovery rate (FDR) control (Storey, 2002), set at 10% (see Chapter 3.7), which calculates the expected proportion of false positives (erroneous rejection of null hypotheses) from the discoveries. FDR ‘families’ were selected based on the lines of analyses they investigated, such that if, for example a set of analyses were examining the behaviours of children who elected for a demonstration, this was considered a ‘family’. Equally, a set of analyses examining children who elected for no demonstration, this was considered a separate ‘family’ and so on.

For brevity, where necessary, I will only describe significant results. For an overview of all results with model beta values, effect sizes and p-values, see Table 4.1. Full details of all regression analyses are provided in Appendix 4.2.

4.2.5 Reliability of parent-teacher personality ratings

Parents and teachers showed good inter-rater reliability when asked to score the same children (ICC, 3k) = .75. ICC scores of .75 and above are deemed good agreement (Koo & Li, 2016), and thus this score suggests good overlap between parent and teacher ratings of participants' personality.

4.3 Results

4.3.1 MMB

4.3.1.1 All participants

Overall, did children elect for social or asocial information?

Overall, 61% ($N = 173$) of children elected for social demonstrations and 39% ($N = 109$) elected to solve the MMB asocially.

Were there age and sex differences in the propensity to elect for social or asocial information?

Across all age groups, females (71%, $N = 103$) were significantly more likely to elect for social demonstrations than were males (51%, $N = 70$; $X^2 = 10.807$, $p = .001$). Children exhibited a negative developmental trend in electing for social information; in Year 3, 69% of children elected for social information, while in Year 4, 62%, Year 5, 61% and Year 6, 54% did so. Across all participants, the mean age of those who elected for prior social demonstrations ($M = 9.27$, $SD = 1.13$) was significantly lower than those who elected to solve the MMB asocially ($M = 9.63$ years, $SD = 1.18$), *Mann-Whitney U* = 11,049.00, $p = .015$.

Did personality predict the propensity to elect for social or asocial information?

The binary logistic regression model was significant (Nagelkerke's $R^2 = .144$, $X^2 = 28.724$, $p < .001$), and the independent variables correctly predicted 83% of those that elected for a demonstration, but only 35% of those that did not. Agreeableness significantly positively predicted the propensity to elect for social information (odds ratio = .569, Wald = 3.938, $p = .047$), and conscientiousness significantly predicted the propensity to elect for asocial learning (odds ratio = 1.733, Wald = 4.144, $p = .042$). Thus, the majority of children elected for demonstrations, although this was driven by females. Older children were more likely to elect to tackle the task without demonstrations than younger children. Agreeableness predicted the propensity to elect for social demonstrations, while conscientiousness predicted the propensity to 'go it alone'. For details of the regression model, see Table 4.1.

4.3.1.2 Assessing the first attempt

Investigating the first attempt of children who elected for a demonstration directly assesses the influence of the social information they received, because for any subsequent attempt participants have gained personal information. Thus, in the next section I examine the fidelity of the first attempts of those who opted for a demonstration to the method observed. For comparison, the first attempts of those who did not elect for a demonstration were used.

Did social learners match the demonstrated methods?

Figure 4.3 displays the percentage of children (who both did and did not observe a demonstration) who matched the demonstrator's behaviours on the first attempt (i.e. each of the following; full imitation, the same tool, the same entrance and the same exit, as the demonstration). Compared to those who elected for no demonstrations, children who received social information were significantly more likely to fully imitate the demonstration (Fisher's Exact Test [FET], $p < .001$) and to specifically use the same tool (FET $p < .001$), the same entrance (FET $p < .001$) and the same exit (FET $p < .001$) as the demonstrator.

Therefore overall, most children who elected for a demonstration were likely to copy the demonstrated methods on their first attempt, while children who did not observe demonstrations rarely exhibited the same techniques.

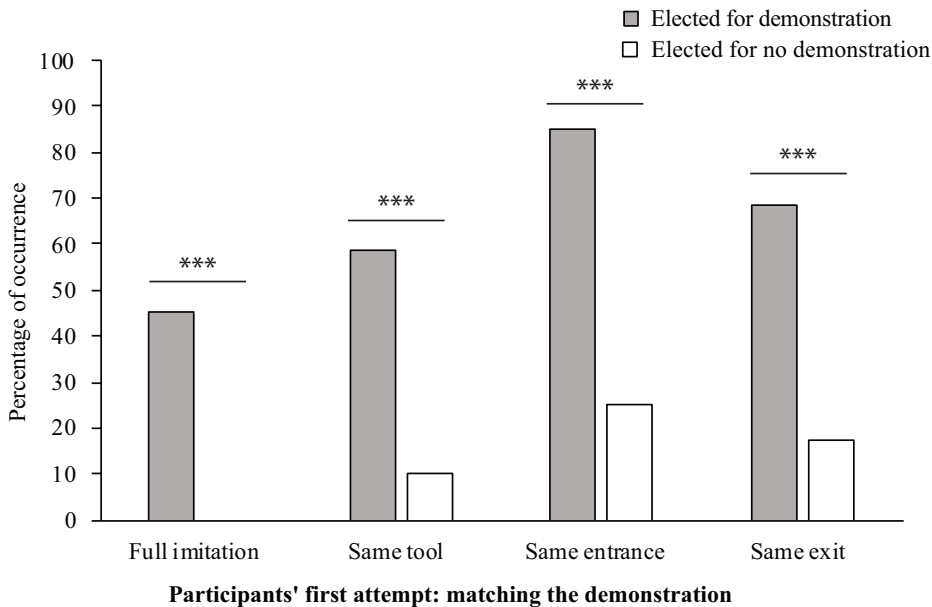

Figure 4.3: Breakdown of the percentages of MMB matching behaviours the same method as the social demonstration by children who elected for demonstrations. For evaluative purposes, the comparative percentages of children who elected for no demonstrations are provided. *** denotes significance at $p < .001$.

4.3.1.3 All participants' behaviours on the MMB combined (all 10 attempts)

The following section presents an overview of the results concerning children's MMB behaviours, including all participants. In all following models, age, sex, learning strategy choice (demonstrations versus no demonstrations) and personality ratings were entered as predictor variables. For an overview of all results with model beta values, effect sizes and p-values, see Table 4.1, and for complete details of all regression analyses see Appendix 4.2.

Age positively predicted the number of successful attempts ($M = 6.72$, $SD = 2.15$, $\beta = .156$, $p = .007$) and the number of exits used ($M = 1.65$, $SD = 0.91$, $\beta = .131$, $p = .022$, although the latter was not considered significant with the application of the false discovery rate), indicating that older children had more successful attempts and potentially used more exits than younger children.

Learning strategy choice significantly predicted the number of successful attempts ($\beta = -.400$, $p < .001$); children who elected for demonstrations ($M = 7.36$, $SD = 1.99$) had more successful attempts than those who elected for no demonstrations ($M = 5.71$, $SD = 2.02$). Learning strategy choice was also a significant predictor of the number of distinct tools used ($\beta = .155$, $p = .013$); children who elected for demonstrations ($M = 2.28$, $SD = 0.89$) used fewer tools than those who elected for no demonstrations ($M = 2.59$, $SD = 1.01$). Similarly, children who elected for demonstrations ($M = 2.08$, $SD = 0.89$) used significantly fewer distinct entrances than those who elected for no demonstrations ($M = 3.08$, $SD = 1.14$; $\beta = .440$, $p < .001$). Finally, children who elected for demonstrations ($M = 1.38$, $SD = 0.79$) used significantly fewer exits than those who elected for no demonstrations ($M = 2.07$, $SD = 0.93$; $\beta = .338$, $p < .001$). Thus, children who elected to solve the MMB asocially used more tools, entrances and exits than children who elected for demonstrations, but were less successful in extracting the reward capsule.

For personality, openness to experience positively predicted the number of entrances used ($\beta = .141$, $p = .039$), but this was not considered significant with the application of the false discovery rate.

Extraversion ($\beta = .127$, $p = .065$) and agreeableness ($\beta = .113$, $p = .067$) showed a trend in positively predicting the number of distinct exits used, tentatively suggesting that children rated as high in these traits used more entrances or exits. Finally, neuroticism ($\beta = -.116$, $p = .066$) showed a

negative trend in predicting success, tentatively suggesting that children rated as high in neuroticism were less likely to extract the reward capsule.

Age did not predict the number of successful attempts, nor the number of distinct tools or entrances children used on the MMB. Sex did not predict the number of successful attempts, nor the number of entrances or exits children used. Males ($M = 2.56$, $SD = 0.93$) used more tools than females ($M = 2.25$, $SD = 0.95$, $\beta = -.123$, $p = .05$), but this was not considered significant under the false discovery rate.

Aside from openness to experience potentially predicting the number of entrances, no other personality trait predicted the number of successes, tools entrances or exits used (all $p > .05$, see Table 4.1).

Table 4.1 Details of all MMB regression analysis conducted (for all participants, children who elected for demonstrations and children who elected for no demonstrations). **Bold type reflects significance at $p < .05$.** +ve denotes significant positive relationships and -ve denotes significant negative relationships. ¹ For binary logistic regressions, Nagelkerke's R^2 is reported.

	Percentage of participants who elected for demonstration					Percentage of participants who elected for no demonstration									
	All Participants		Females		Males	All Participants		Females		Males					
	61%		71%		51%	39%		29%		49%					
Regression analyses for all participants						Regression analyses for participants who elected for demonstrations					Regression analyses for participants who elected for no demonstrations				
	Learning Strategy $R^2 = .135^1$	Success attempts $R^2 = .177$	No. of tools $R^2 = .055$	No. of entrances $R^2 = .210$	No. of exits $R^2 = .019$	No. exact imitations $R^2 = .020$	No. tool innovations $R^2 = .018$	No. entrance innovations $R^2 = .055$	No. exit innovations $R^2 = .130$	Deviation score $R^2 = .031$	No. of tools $R^2 = .042$	No. of entrances $R^2 = .033$	No. of exits $R^2 = .101$	Novelty score $R^2 = .057$	No. of repeats $R^2 = .059$
Age		+ve			+ve				+ve	+ve					
Beta	.238	.156	-.040	-.006	.131	.012	.029	.135	.295	.176	-.107	-.106	-.047	-.123	.092
p-value	.039	.007	.522	.917	.022	.881	.713	.086	< .001	.024	.305	.312	.642	.237	.375
Sex															
Beta	.845	-.024	-.123	-.006	-.062	.064	-.050	-.105	-.002	-.075	-.105	.033	-.071	-.060	.104
p-value	.002	.679	.050	.910	.286	.424	.534	.184	.974	.338	.306	.745	.476	.554	.305
Extraversion					+ve										
Beta	.279	-.048	.042	-.047	.127	-.040	-.047	-.047	.034	-.036	.040	-.086	.058	-.002	-.059
p-value	.253	.488	.572	.484	.065	.675	.632	.622	.712	.704	.751	.499	.635	.990	.639
Agreeableness	Social				+ve										
Beta	-.564	.001	.072	.004	.113	.014	-.062	-.006	.080	-.010	.124	-.035	.287	.158	-.173
p-value	.047	.990	.281	.950	.067	.873	.475	.942	.327	.905	.268	.753	.009	.156	.121
Conscientiousness	Asocial														
Beta	.550	.012	-.105	-.081	-.098	.047	-.052	-.103	-.109	-.111	-.117	.054	-.122	-.077	.133
p-value	.042	.865	.160	.238	.158	.634	.602	.293	.244	.250	.330	.656	.296	.521	.267
Neuroticism		-ve													
Beta	.102	-.116	-.030	-.028	.013	-.046	.045	.023	.128	.079	.011	-.067	-.091	-.067	-.101
p-value	.579	.066	.654	.653	.832	.604	.612	.789	.126	.359	.920	.557	.408	.551	.367
Openness					+ve										
Beta	.229	-.028	-.001	.141	.101	-.117	.029	.135	.215	.210	-.003	.139	.040	.751	-.102
p-value	.300	.687	.985	.039	.144	.244	.713	.058	< .001	.032	.305	.236	.722	.454	.380

4.3.1.4 Assessing children who elected for demonstrations and for no demonstrations separately (all 10 attempts)

I next present the data on whether personality predicted MMB behaviours for children who elected for social demonstrations and those who elected for no demonstrations separately. Table 4.1 presents model details (R^2 , beta and p-values) for all of the following analyses, and similarly, Appendix 4.2 provides a comprehensive breakdown of all of the following analyses.

Children who elected for a demonstration

Within children who elected for social demonstrations, age positively predicted the number of exit innovations ($M = 0.89$, $SD = 1.98$, $\beta = .295$, $p < .001$) and children's composite deviation score ($M = 7.61$, $SD = 5.78$, $\beta = .176$, $p = .024$), suggesting that older children were more likely to deviate from the witnessed demonstrations than younger children. Openness to experience positively predicted the number of exit innovations ($\beta = .215$, $p = .024$), and children's deviation scores ($\beta = .210$, $p = .032$). Additionally, openness to experience approached significance ($\beta = .188$, $p = .058$) in predicting the number of entrance innovations ($M = 2.50$, $SD = 2.54$). Therefore, children rated higher in openness to experience were more likely to deviate from the demonstrated methods than children rated as lower in openness to experience.

Age, sex and the other personality traits did not predict any other dependent variables.

Children who elected for no demonstrations

Of the children who elected for no demonstrations, agreeableness positively predicted the number of exits used ($\beta = .287$, $p = .009$), but with the application of the false discovery rate, this was not considered significant. No other relationship reached significance (all $p > .05$). Accordingly, age, sex

and personality did not predict the number of distinct tools, entrances and exits children used, nor their composite novelty score.

4.3.3 The Hook Task

In order to investigate whether learning strategy choice showed any relationship with personality and/or innovation-by-invention performance, I examined children's performance in the Hook Task in relation to learning strategy choice. I first report children's overall performance and its relationship with personality, before comparing the performance of social and asocial learners in terms of techniques used and efficiency.

4.3.3.1 Overall performance and personality

Altogether, 82% ($N = 230$) of participants succeeded in retrieving the sticker reward with the pipe cleaner, and 18% ($N = 52$) failed to retrieve the reward. Given the age range of participants, is in line with findings from other studies (Beck et al., 2011, 2016).

The binary logistic regression model approached significance, (Nagelkerke's $R^2 = .144$, $X^2 = 13.711$, $p = .057$). The independent variables correctly predicted 99.6% of those who succeeded, but 0% of those who failed. Age (odds ratio = 1.363, Wald = 4.775, $p = .029$) positively predicted success, although this was not considered significant with the application of the false discovery rate. Agreeableness (odds ratio = 1.927, Wald = 4.235, $p = .040$) also positively predicted success, although this was also not considered significant with the application of the false discovery rate. Sex, nor any other personality traits were significant predictors (all $p > .05$).

Overall, there were two main techniques to retrieve the reward; 1) manipulating the pipe cleaner into a hook shape to retrieve the sticker reward, and 2) a ‘dragging’ technique, where children used the straight pipe cleaner to push the bucket against the side of the apparatus and drag it to within reach. A small number of participants also used a different technique, including manipulating the pipe cleaner into a ‘pincer’ shape, or tying the string to the pipe cleaner and fishing the sticker out. These rare techniques were pooled together and classed as ‘alternative technique’.

Including all participants, 55% ($N = 156$) used the hook technique, 22% ($N = 61$) used the dragging technique, and 5% ($N = 13$) used an alternative technique (18% failed to retrieve the reward).

Multinomial logistic regression indicated that the overall model was significant (Nagelkerke’s $R^2 = .144$, $X^2 = 24.170$, $p < .001$). Age was a significant predictor of the technique used ($X^2 = 23.611$, $p < .001$), but sex was not. Age positively predicted the propensity to use the hook technique compared to the dragging technique (odds ratio = .513, Wald = 14.279, $p < .001$), suggesting older children were more likely to manipulate the pipe cleaner to create a tool, whilst younger children were more likely to attempt to use the pipe cleaner in its original state. No other comparisons were significant, although extraversion (odds ratio = 3.399, Wald = 3.681, $p = .055$) approached significance in positively predicting the propensity to use an alternative technique.

The efficiency of each technique was calculated using latency to succeed (s). The hook technique was the most efficient technique (Mean latency to succeed = 38.62, $SD = 27.64$), followed by the dragging technique ($M = 53.79$, $SD = 37.92$). The alternative techniques were the least efficient ($M = 76.85$, $SD = 38.41$). This difference was significant (*Kruskal-Wallis* $H = 20.327$, $df = 2$, $p < .001$), and pairwise comparisons revealed that the hook technique was more efficient than the dragging technique ($p = .008$)

and the alternative techniques ($p < .001$). The difference between the dragging and alternative techniques was not significant ($p = .114$).

4.3.3.2 Comparing those who elected for demonstrations with the MMB versus those who did not

Regardless of learning strategy with the MMB, children showed identical rates of success on the Hook Task (social demonstration: 82%, $N = 141$; no demonstration: 82%, $N = 89$).

Within those that elected for demonstrations, 47% ($N = 82$) used the hook technique, 29% ($N = 50$) the dragging technique and 5% ($N = 9$) an alternative technique (19% failed to retrieve the reward). Within children who elected for no demonstrations, 68% ($N = 74$) used the hook technique, 10% ($N = 11$) used the dragging technique and 4% ($N = 4$) used an alternative technique (18% failed to retrieve the reward, see Figure 4.4).

I ran a multinomial regression analysis, with Hook Task method (fail, hook, drag, alternative) entered as the dependent variable and age, sex and learning strategy (demonstrations versus no demonstration with the MMB) as predictor variables (see Table 4.2). For the dependent variable, the hook method was used as the reference. The model was significant ($X^2 = 46.785$, $p < .001$, Nagelkerke's $R^2 = .171$). Age ($X^2 = 26.947$, $p < .001$) and learning strategy ($X^2 = 15.107$, $p = .002$) were significant predictors of the methods children used on the Hook Task, while sex was not. Specifically, older children were less likely to fail (odds ratio = .664, Wald = 7.624, $p = .006$) and were less likely to use the dragging technique (odds ratio = .546, Wald = 16.391, $p < .001$) than younger children. Further, those that opted to attempt the MMB task asocially were more likely to use the hook method compared to those that opted for a social demonstration, who were more likely to use the dragging technique (odds ratio = 3.909, Wald = 12.369, $p < .001$).

As personality traits (for example conscientiousness) could have driven these results, I ran the multinomial regression again with personality ratings added as covariates. The results remained the same (see Appendix 4.2).

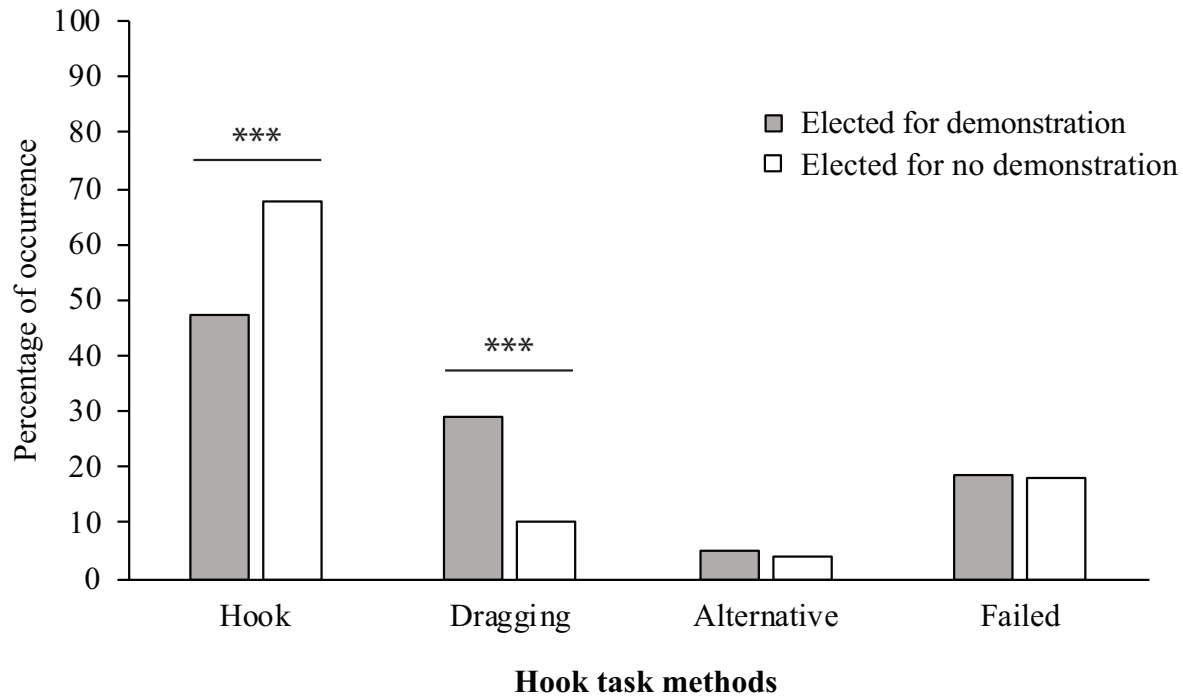

Figure 4.4: A breakdown of the percentage of children selecting demonstrations and children selecting no demonstrations with the MMB using each technique on the Hook Task.

4.3.4 Alternate Uses task

I now report children’s performance on the Alternate Uses task. I first report overall performance for fluency and originality and their relationship with personality ratings, before comparing the performance of children who elected for demonstrations with children who opted for no demonstrations.

4.3.4.1 Overall performance

Fluency

Overall, children named a mean of 4.94 ($SD = 3.06$) different uses for a paperclip. Age positively predicted fluency scores ($\beta = .345, p = .032$), although this was not considered significant with the application of the false discovery rate. Similarly, sex ($\beta = .345, p = .041$) was also a predictor with males ($M = 5.38, SD = 3.68$) displaying higher fluency scores than females ($M = 4.53, SD = 2.28$), although this was also not considered significant with the application of the false discovery rate, tentatively suggesting that older children and males displayed higher scores of divergent thinking. No personality trait predicted fluency scores on the Alternate Uses task (all $p > .05$).

Originality

Children scored an Alternate Uses originality mean of 4.07 ($SD = 5.74$). Age, sex and personality did not predict children's Alternate Uses originality scores (all $p > .05$).

4.3.4.2 Comparing children who elected for demonstrations with the MMB with those who did not

Two linear regression analyses were conducted where age, sex and learning strategy choice (demonstration = 0, no demonstration = 1) were entered as predictor variables, and Alternate Uses fluency and originality were entered as dependent variables, respectively (see Table 4.2 for descriptive details).

Fluency

The model was significant ($R^2 = .062, F = 6.087, p = .001$). Controlling for age and sex, learning strategy choice with the MMB significantly predicted children's fluency scores on the Alternate Uses task ($\beta = .173, p = .004$), with children who elected for no demonstrations ($M = 5.74, SD = 3.93$) scoring higher than children who opted for demonstrations ($M = 4.44, SD = 2.23$).

Originality

The model for this analysis was significant ($R^2 = .035$, $F = 3.386$, $p = .029$). Controlling for age and sex, learning strategy choice with the MMB also significantly predicted children's originality scores (beta = .133, $p = .029$), with children selecting to attempt the MMB asocially ($M = 5.21$, $SD = 7.42$) scoring higher than children selecting social information ($M = 3.35$, $SD = 4.22$). Thus, children who elected for no demonstrations generated more uses overall, and more unique uses for a paperclip than children who opted for demonstrations.

Table 4.2: Performance on the Hook and Alternate Uses Tasks, broken down by learning strategy choice.

Hook task method (percentage of participants)				
	Hook	Drag	Alternative	Fail
Elected for demonstration	47.4	28.9	5.2	18.5
Elected for no demonstration	67.9	10.1	3.7	18.3

Number of Alternative Uses		
	Fluency (SD)	Originality (SD)
Elected for demonstration	4.44 (2.23)	3.35 (4.22)
Elected for no demonstration	5.74 (3.93)	5.21 (7.42)

4.4 Discussion

This study investigated whether personality predicted the learning strategies seven- to 11-year old children adopt when faced with a novel multi-methods puzzle-box (MMB). Children rated by their parents as high in conscientiousness were more likely to elect to interact with the MMB asocially, while children rated highly in agreeableness were more likely to elect for social demonstrations before

interaction. Further, of those that elected for social demonstrations, openness to experience predicted the tendency to deviate from the observed methods. Children who elected to solve the MMB asocially were both more likely to manufacture a tool to solve an innovation challenge and displayed higher scores on a measure of divergent thinking, compared to those who elected for social demonstrations. These data not only represent the first evidence that personality predicts children's learning strategy choices, but also provides evidence that explicit learning strategy choices correlate with children's performance on measures of innovation and creativity.

4.4.1 The role of personality: Agreeableness, conscientiousness and openness matter

Children rated as more agreeable were more likely to ask for social demonstrations before tackling the MMB than those rated as less agreeable. Agreeableness denotes the tendency to be prosocial, trusting, cooperative and kind; traits that lend themselves to electing for social information over asocial information. For instance, adult and child studies have reliably demonstrated that agreeable individuals are more trusting of strangers (and familiar others) than less agreeable children (Freitag & Bauer, 2015; Gerris, Delgado, & Oud, 2010; Mooradian, Renzl, & Matzler, 2006; Soto & John, 2012). It is possible that children rated as more agreeable in this study were more trusting of the demonstrator's intentions and/or ability to solve the MMB than less agreeable children. Further, highly agreeable individuals are motivated to establish positive relationships with others (Barrick, Stewart, & Piotrowski, 2002). Since children copy others for affiliative motives (Over & Carpenter, 2012; Schleihau et al., 2018) - as well as informational ones (Lyons et al., 2007) - and being imitated induces positive affect towards the 'imitators' (Chartrand & Bargh, 1999) it is also possible that the more agreeable children elected for social information to establish a positive relationship with the demonstrator.

That conscientiousness predicted the tendency to attempt to solve the MMB asocially was not predicted. Conscientiousness is characterised by being industriousness, organised and well-planned. I propose two

working theories to explain this finding. First, conscientiousness is strongly correlated with performance in academic (Poropat, 2014b) and non-academic (Scher & Osterman, 2002) settings, and is linked with increased self-efficacy (the belief in one's own ability, Lee & Klein, 2002). One possibility therefore, is that the children rated as highly conscientiousness had confidence in their self-efficacy, perhaps resulting from high achievement. Recent work has shown that low task-related confidence is a contributing factor in the propensity to conform to social information (Cross, Brown, Morgan, & Laland, 2017; Morgan, Rendell, Ehn, Hoppitt, & Laland, 2012). Thus, highly conscientious children may have been confident enough in their own ability to tackle the MMB without demonstrations. Alternatively, high conscientiousness has also been correlated with 'overcontrollingness' (the tendency to exert control over others and to want to be in control of a given situation Donnellan & Robins, 2010; Lepine, Colquitt, & Erez, 2000). As such, another potential explanation for children rated as highly conscientiousness electing for no prior demonstrations could be related to enabling them to gain quicker control over the situation, rather than yielding initial control to the experimenter/demonstrator.

These suggestions are speculative; it would be interesting in the future to test these hypotheses. For instance, additional measures of belief in self-efficacy and desire to control situations would allow an initial assessment of these variables on children electing for asocial information's influence on decisions to forego acquiring social information and 'go it alone'. Similarly, measures of trust and desire for social integration would allow an assessment of whether the highly agreeable children that elected for prior demonstrations did so for affiliative and/or trust-related reasons.

Within the children who chose a social demonstration, openness to experience predicted their propensity to deviate from witnessed methods. In line with Carr et al. (2015) children who experienced an MMB demonstration were generally unwilling to deviate from the demonstrated methods (also see Wood et al.,

2013). Children's learning of an object's function can inhibit their recognition of potential different uses and solutions (termed functional fixedness, German & Defeyter, 2000). However, children who were rated as high in openness to experience showed a greater capacity to deviate from social demonstrations. Their natural curiosity, inventiveness and tendency to explore may allow them to circumvent prepotent responses of copying the socially learned methods of the MMB, and to apply novel techniques. Indeed, when including all participants in this study, children rated high in openness to experience used more entrances than those rated low in openness, indicating that they were generally more exploratory on the MMB than those rated low in openness to experience.

In contrast to my hypothesis, and several previous studies (see Rawlings et al., 2016), extraversion was not correlated with opting for social information. It is unclear why this relationship did not manifest. One possibility is the differences in instruments used to assess extraversion and age of participants. In the current study I used an abbreviated measurement of the Big Five personality traits (Asendorpf & van Aken, 2003) and tested seven- to 11-year olds. In both previous studies reporting this relationship, extraversion was assessed using the Infant Behavioural Questionnaire (IBQ) - a measure of temperament aimed at infants (Gartstein & Rothbart, 2003) and participants were two- (Canfield et al., 2015) and one-years old (Hilbrink et al., 2013). While both personality instruments incorporate questions about children's activity levels and gregariousness, measurements of the Big Five capture loadings such as assertiveness and dominance, while instead the IBQ captures loadings such as perceptual sensitivity and vocal reactivity. Thus, one plausible explanation is the differences in how the different instruments capture characteristics of extraversion (as well as the different age groups tested).

However, extraversion was tentatively linked to children's propensity to use an alternative method on the Hook Task (such as combining the string and pipe cleaner or manufacturing a pincer shape from the

pipe cleaner). Generating these rare techniques may represent a form of (tool-use) divergent thinking. While extraversion has a mixed link with creativity (Chamorro-Premuzic, Furnham, & Lewis, 2007), Chamorro-Premuzic and Reichenbacher (2008) found that extraversion positively predicted adult divergent thinking (measured by verbal fluency and creative problem solving) particularly when under threat of evaluation. The authors suggested that such findings were consistent with claims that the arousing effects of evaluation facilitate highly extraverted individuals' creative performance (and conversely inhibit introverted individuals' performance) (Eysenck, 1977). The results here potentially converge with these findings; in individual testing conditions, and being observed by an adult experimenter, children rated as more extraverted were more likely to generate unusual methods to solve the Hook Task.

4.4.2 Age and sex differences

Older children showed an overall greater propensity to elect to solve the MMB asocially than younger children. Flynn et al. (2016) found that 76% of three- and five-year olds elected for social demonstrations for puzzle-box tasks. In contrast, Mesoudi (2011) found that 77% of adults employed individual (asocial) learning on a computer based artefact design task. The results presented in this study fit in-between these two findings to indicate that with increasing age, humans display a lower propensity to use social information: overall 61% of the seven- to 11-year old participants elected for social demonstrations. Further, across the age range tested here, children displayed a linear developmental trend corresponding with this phenomenon; 69% of the youngest age group (seven- to eight-years) elected for demonstrations compared to 54% of children in the oldest age group (10- to 11-years). In unison, these data suggest a developmental trend to bypass social information when it is available.

Relatedly - and also in line with Carr et al. (2015) - within participants electing for demonstrations, older children were more likely to deviate from witnessed methods, particularly with regards to exit innovations. The task was devised so that exit innovations were the only way to improve efficacy; using different tools and entrances represent innovative deviations but are no more beneficial than the demonstrated method (Carr et al., 2015). Carr and colleagues proposed that maturing cognitive mechanisms such as flexibility and executive functions may underpin older children's greater capacity to depart from the observed behaviours (i.e. inhibit prepotent responses, future planning) in a way that increased efficacy, and that older children were less likely to interpret adult demonstrations as normative (Schillaci & Kelemen, 2014). By testing an older age range, the current findings expand upon the findings of Carr et al. (2015). Crucially though, to provide direct evidence for this hypothesis, future work should measure the role executive functions play in children's propensity to deviate from social information.

Females were significantly more likely than males to elect for social information. This is, to my knowledge, the first evidence of sex differences in learning strategy use in children. In adults, meta-analyses of conformity (as measured by deference to a majority) have shown that females conform to others more than males (Bond & Smith, 1996), and recent work suggests that confidence and task type (Cross et al., 2017; Morgan et al., 2012), as well as risk aversion (Brand, Brown, & Cross, 2018) may be mediating factors in females' greater use of social information. By explicitly offering a choice of social or asocial information, the results here converge with the notion that females show a greater proclivity for social information. Given that electing to go it alone was a riskier strategy than electing for social demonstrations (as demonstrated by the lower success rate of those electing to 'go it alone'), this finding also supports the idea that risk aversion plays a role in sex differences in social information use.

Additionally, electing for social demonstrations meant inhibiting the desire to directly interact with a novel apparatus in order to witness someone else do so first. In children and adults, females show greater levels of delayed gratification (Silverman, 2003) and self-regulation (Hosseini-Kamkar & Morton, 2014) than males. That is, females show a greater capacity to inhibit impulsive and immediate responses for delayed (and often greater) rewards. Consequently, an additional potential factor in sex differences in learning strategies (when explicitly and directly pitted against one another) may be the ability to delay immediate responses for later gains. Future work could attempt to disentangle whether risk, confidence and/or delayed gratification played a role (and if so, how much of a role) in females' greater propensity to elect for social demonstrations than males.

4.4.3 Cross-task consistency: The relationship between puzzle-box learning strategy choice and performance on innovation and creativity tasks

When controlling for age and sex, children who elected for no demonstration were significantly more likely to display tool manufacture (creating a hook shape) in response to an innovation challenge than compared to those who elected for a demonstration (who used the pipe cleaner in its original state in a dragging technique) and outperformed social learners on a divergent thinking task. The hook method ostensibly represents a more erudite (and efficient) technique than the dragging technique, requiring a two-step process of imagining an appropriate tool type and physically manipulating the tool in to the appropriate shape (Beck et al., 2011; Beck, Chappell, Apperly, & Cutting, 2012). With regards to the Alternate Uses task, children who explicitly elected to solve the MMB asocially generated both more overall uses for a paperclip, and more unique uses, compared to those who elected for a demonstration. Thus, individuals who were prepared to bypass social information on a puzzle-box produced both a greater quantity of, and a higher novelty of, ideas than those who requested social information.

These results provide the first evidence that children overtly willing to tackle novel problems asocially are more innovative and creative on a variety of tasks compared to those who turn to social information. On face value, using social information when available appears a productive strategy, as it allows children to quickly acquire task appropriate information with a relatively low cognitive load. However, perhaps over time, children that are willing to tackle novel problems asocially acquire the cognitive resources (i.e. flexibility, creativity) to engage in successful innovation. Indeed, nonhuman animal work has shown that frequency of exposure to innovation-facilitating conditions promotes innovative abilities at the group level (Gruber et al., 2016; Koops et al., 2014), and that bolder individuals who actively seek novel situations show a higher innovation propensity than shyer individuals (Call, 2015; Griffin, Netto, & Peneaux, 2017; Lermite et al., 2016).

4.5 Conclusions and Implications

Explicitly offering children a choice of solving a novel puzzle-box asocially or to witness social demonstrations first, coupled with personality measurements, provided the opportunity to assess *who* overtly elects to adopt specific learning strategies. These findings shed new light on how new cultural traditions may emerge and establish by allowing us to understand which individuals are likely to be those that generate new cultural variants in populations - either by novel invention (children rated as high in conscientiousness children were more likely to elect to solve a puzzle-box asocially) or by modifying observed behaviours (children rated as high in openness to experience were more likely to deviate from social information) – and those that may be influential in the social diffusion of these variants (children rated as high agreeableness tended to elect for social demonstrations).

Further, the addition of a novel hook invention task and a measure of creativity revealed a not-before-seen link between children willing to bypass social information and innovative and creative

performance. These findings provide complementary developmental perspectives to established nonhuman work that has shown a relationship between the proclivity to actively interact with novel stimuli and/or engage in novel situations, and innovative propensity.

Chapter 5: Innovators have many friends: Investigating the relationship between children’s social network properties and the propensity to copy or innovate.

This chapter investigates the relationship between social network positions and learning strategy use in children. Dr. Dan Franks, University of York, provided statistical supervision for social network analyses, and will have authorship on any subsequent publication(s) stemming from this chapter.

Abstract

Innovation and social learning are the dual pillars of cultural evolution. Recent theoretical and empirical developments have highlighted the importance of the social environment for both social learning and innovation. Currently, however, we know almost nothing about whether individual differences in sociality correlate with individual differences in learning strategy use. This study examined whether, when faced with a novel problem, children’s individual-level social network characteristics influenced their propensity to generate solutions individually or observe others. One hundred and fifty-five seven- to 11-year olds were presented with a novel, tool-use puzzle-box task - the multi-methods box. All participants were asked by an experimenter “Would you like to have a go yourself, or would you to watch me to have a go first?” For those that elected for a demonstration, an adult experimenter performed the same technique four times. Then each child had ten attempts at retrieving sticker rewards from the box. All participants were also presented with an innovation challenge known to be difficult for young children (the Hook Task) and a measure of divergent thinking (the Alternate Uses Task). Social network measures were obtained through ‘social cognitive mapping’, where children named friendship groups from their school class.

Node-level regressions revealed that network measures did not predict the propensity to elect for social demonstrations or for no demonstrations. However, degree centrality— denoting the number of connections (or ‘friends’) an individual has – was consistently linked to other forms of innovation and exploration. For those who elected for social demonstrations, across their ten subsequent attempts, individuals with many friends (high degree centrality) were more likely to deviate from demonstrated methods than children with lower degree scores. Further, of the children who elected for no demonstrations, those with high degree centrality were less likely to repeat previously used techniques across their ten attempts than children with low degree centrality. Social network measures showed no relationship with performance on the Hook or Alternate Uses tasks.

This is, to my knowledge, the first study to correlate individual differences in social network measures with children’s learning strategy use and thus sheds light on what may differentiate individual problem solvers from those that look to others. These findings correspond with work from industry settings and nonhuman animal work showing that both companies and individuals with more connections (high degree) showed greater innovative propensity.

5.1 Introduction

All socially living species have the potential to obtain information from conspecifics. For many species, this a particularly valuable tool, allowing individuals to quickly learn new and important skills or behaviours. Children, in many ways, are a prime example; in our increasingly complex world children rely on observing others (social learning) to learn how to navigate the physical and social environment (Legare & Nielsen, 2015; Lyons et al., 2007) and to learn the conventions of peers and thus to maintain cultural homogeneity (Laland, 2004; Legare & Nielsen, 2015; Schleihauf et al., 2018).

Nonetheless, social learning is not always optimal; information obtained from others is occasionally unreliable, outdated or difficult to obtain. In such instances, asocially innovating new behaviours or solutions is often a more viable strategy (Kendal et al., 2009); asocial information provides direct, up-to-date environmental information. Yet, individually acquiring information can be a costly, error-prone and a time-consuming process. Children thus face a trade-off regarding whether to solve problems using social or asocial information (Kendal et al., 2009; Laland, 2004).

Cultural diversification relies on innovation and social learning for the generation and dissemination of behavioural variants (O'Brien & Shennan, 2010). As such, the importance of innovation and social learning for cultural evolution has seen much recent research focus directed towards individual differences in the use of specific learning strategies, with the aim of understanding whether specific characteristics differentiate individuals showing a greater propensity to use social or asocial information (see Chapter 2 and Chapter 4.1 for detailed discussion of the literature on individual differences in learning strategy use).

One factor that has been overlooked in the literature – particularly from a developmental perspective - is whether children’s specific role within their social group influences their propensity to use social or asocial information. This may be an important omission in the literature; nonhuman animal work indicates that group members vary in their interaction rates with one another, such that not all individuals in a social group have equal opportunities for observing others (Croft, Madden, Franks, & James, 2011). Individuals holding peripheral positions in their social group presumably have less exposure to others’ behaviours, and consequently experience fewer opportunities to obtain social information than individuals holding central positions, who likely experience greater opportunities for copying (Flynn & Whiten, 2012; Turner & Flynn, 2016). Yet, we currently know little about whether individual differences in social network positioning correlates with individual differences in learning strategy use in humans or nonhumans.

Another important reason to consider social-environment related influences on learning strategy use is to broaden our knowledge of how different types of innovation may occur. There has been recent emphasis on the social drivers of innovation (by-modification) to complement the traditionally-studied asocial (by-invention) drivers (Carr et al., 2015, 2016; Hopper, 2016; Muthukrishna & Henrich, 2016). Specifically, we are beginning to understand how innovations often stem from improving or modifying the skills, products or behaviours of others (innovation-by-modification; Carr et al., 2016), and that group dynamics, such as group size and inter- and intra-connectedness, play an important role in rates of innovation (Muthukrishna & Henrich, 2016). The previous empirical chapter (Chapter 4) indicated that there may be intrinsic individual differences in the propensity to engage in both innovation-by-modification and innovation-by-invention. Accordingly, investigating whether individual differences in social network positions correlate with the propensity to engage in social learning or innovation of both types will build on the previous chapter and the aforementioned recent developments in the literature, to

further our understanding of the role social networks play in copying as well as asocially- and socially-mediated innovation.

Ostensibly, the social environment should influence children's problem-solving approaches. Throughout childhood, children's social networks become increasingly complex, fluid and influential (Ladd & Kochenderfer, 1996), and even from early childhood, classroom social networks predict educational achievement (Schneider, Ford, & Perez-Felkner, 2010) and classroom engagement (Cappella et al., 2012) and conflict (Moultapa et al., 2004). Although we know little about whether the social environment influences children's problem solving strategies, we can be informed by work from other fields – most notably from the fields of business studies and zoology/comparative psychology (Rawlings et al., 2017).

Studies largely from these fields suggest two ways in which the social environment may shape the learning strategies individuals adopt. First, there is evidence to suggest that individuals who occupy central roles in their social group (i.e. those with many and frequent social interactions) are more prone to observing and copying others, while peripheral members are more likely to exhibit innovation. For instance, two- to four-year old children rated as more popular observed others (and were observed) more when engaging with a novel puzzle-box task (Flynn & Whiten, 2012). The authors suggested that since children prefer social learning, the copying by popular individuals may have resulted simply from their greater proximity to others rather than through conscious choice of whom to observe (also see Coussi-Korbel & Fragaszy, 1995; Turner & Flynn, 2016). Network centrality (the extent to which individuals have both several and strong ties with group members) positively correlates with classroom popularity (Farmer & Farmer, 1996), and thus it may indeed be that central individuals copy others as a function of greater exposure to peers' behaviour. Social network studies have also shown that adults are more likely

to acquire behaviours (either harmful or beneficial) from close contacts in their networks (Aral & Walker, 2011; Backstrom, Huttenlocher, Kleinberg, & Lan, 2006; Centola, 2010; Christakis & Fowler, 2008). In one example, using data from a large-scale city social network, smokers and non-smokers clustered with other smokers and non-smokers, respectively, and cessation of smoking by a close network contact (i.e. family member or friend) dramatically reduced the chances of an individual smoking (Christakis & Fowler, 2008). Similar findings, regarding the utility of close contacts have been reported with uptake of marketplace products (Aral & Walker, 2011) and participation in community social groups (Backstrom et al., 2006).

Animal studies indicating that peripheral group members are more likely to innovate than central members also provide tentative support for the link between network centrality and social information use. In a collation of the nonhuman primate literature, Reader and Laland (2001) found that poor competitors (i.e. low ranking) exhibited greater rates of innovation than better competitors. The authors suggested that limited resource access of such peripheral individuals ‘forced’ poor competitors to innovate (termed the ‘necessity hypothesis’). Similarly, Sigg (1980) reported that peripheral female hamadryas baboons were significantly better at learning novel tasks than central females. These studies potentially suggest that less central individuals are those that show a greater propensity to engage in, and are more successful at, innovation. However, the relationship between social rank and network centrality is unclear (Funkhouser, Mayhew, & Mulcahy, 2018), and there is also growing evidence disputing the necessity hypothesis (see Koops, Visalberghi, & van Schaik, 2014).

In direct contrast to the above studies, there is also evidence from the same fields indicating that network centrality positively predicts innovation. In particular, two specific measures of centrality appear to be of importance; betweenness and degree centrality. While both are measures of individual-level network

positions, they each capture different aspects of network centrality. Betweenness centrality denotes the tendency to connect several unconnected group members, such that high betweenness individuals act as a ‘bridge’ between several group members. Studies largely from business settings have revealed that measures of betweenness centrality predict industry measures of innovation (as measured by publications, awards and ratings). In children, seven- to 11-year olds who were classified (through behavioural observations and peer nominations) as having high betweenness centrality were also rated as more innovative on an online app design task, compared to those who did not connect group members (Kratzer & Lettl, 2008). Similarly, adult employees scoring highly in betweenness centrality, and those with many-but-weaker network ties, are particularly innovative and creative in industry settings (Baer, 2010; Baer et al., 2015; Zhou et al., 2009).

Degree centrality simply denotes the number of connections an individual has – individuals with higher degree centrality have a greater number of associations within a network. In business settings, ‘lead users’ (those who are innovative problem solvers in the marketplace) tend to be highly connected in their social networks (Franke & Shah, 2003), and more globally, companies with higher degree centrality values are more innovative (measured by patents) than less connected companies (Aktamov & Zhao, 2014; Wang et al., 2015). Business theorists suggest that having many connections facilitates workplace innovation through two related processes; first, connectedness means a greater exposure to a wide range of information, skills and behaviours (often through collaborations) which can then be synthesised into novel ideas (Aktamov & Zhao, 2014; Baer et al., 2015; Kratzer & Lettl, 2008). Second, exposure to many peers may allow well-connected individuals to refine others’ ideas and innovations in a process analogous to innovation-by-modification (Fleming & Waguespack, 2007).

Nonhuman animal studies provide further evidence for a link between network centrality and innovation propensity. Wild *paridae* birds with both more group connections and high betweenness centrality were more likely to discover new food patches than less central individuals (Aplin et al., 2012), while captive squirrel monkeys with higher centrality were more likely to innovate (and socially learn) solutions to a novel puzzle-box. Finally, crows that engaged in more affiliative and aggressive interactions with group members performed better at social and non-social cognitive tasks than those that engaged in fewer such interactions (Wascher, 2015).

In summary, evidence is mixed with regards to how an individual's social environment shapes the propensity to engage in specific learning strategies when faced with novel problems. On the one hand, being gregarious, popular and well-integrated has been shown to facilitate social learning, most likely through a combination of sheer exposure to others' behaviours. Alternatively, having many and strong social connections also appears to promote innovation, potentially as a result of exposure to a diversity of information. These findings may in part reflect species differences, and in part the disparate measures used within and across taxa. However, these findings may also need not be mutually exclusive; being central may facilitate both social information use (through exposure to others' behaviours) and innovation (through exposure to informational diversity). The objective of this study is to directly investigate these two theories in children by using a modern, quantitative technique prevalent in the nonhuman animal literature, social network analysis (SNA). I will use this approach to establish whether children's individual roles within their social groups influences their choice of solving a novel task through acquisition of social or asocial information

SNA is the systematic evaluation of social interactions and associations (proximity) between individuals. SNA allows the quantification of network properties at the group and individual levels,

detailing a population's global social properties and each individual's role within the network (i.e. their centrality). SNA has become a powerful technique in the study of cultural evolution, and has proven especially fruitful in allowing researchers to systematically track the spread of new behaviours within groups of humans and animals (Centola, 2010; Christakis & Fowler, 2008; Farine, Aplin, Sheldon, & Hoppitt, 2015; Hobaiter et al., 2014; Mann et al., 2012). While these developments have been extremely informative for our understanding of how novel information or innovations diffuse throughout populations, the role of individual-level network properties on learning strategy use have been largely overlooked in network-based studies of cultural evolution. As such, the use of social network analysis to assess whether individual-level network measures predict learning strategies remains underexplored.

Chapter 4 investigated whether an intrinsic factor (personality) predicted children's learning strategies when faced with a novel puzzle-box. The current study used the puzzle-box data from a subset of the same children that participated in the previous empirical chapter, for whom additional social network data was collected. By examining the same children on the same measures, the objective of this study was to assess whether an extrinsic factor, social network position, predicted the learning strategies children explicitly adopt.

Based on previous studies empirical studies instigating the relation between the social environment and the use of social information and innovation in children and adults, I hypothesised that children's social network positions would influence learning strategies. Because the literature has indicated that high and low centrality is related to social information use and innovation, I predicted that this this would be the case in one or both of the following alternative ways:

- a. Children with higher centrality (as measured by degree and/or betweenness centrality) would be more likely to use social information (Centola, 2010; Christakis & Fowler, 2010; Flynn & Whiten, 2012).
- b. Children with higher centrality (as measured by degree and/or betweenness centrality) would be related to innovation (Baer et al., 2015; Kratzer & Lettl, 2008; Kratzer et al., 2016).

As the relationship between age, sex and learning strategy behaviours were examined in the previous empirical chapter with the full cohort of participants (Chapter 4.3), they were not explicitly investigated here, and thus no predictions were made. However, to control for their influence, they were included as covariates in the analyses. Further, as with Chapter 4, the relationship between age, sex and social network positions (and their interactions) will not be presented, as they are not within the focus of the theoretically driven investigation.

5.2 Methods

5.2.1 Participants

Participants were a subset of those that participated in Chapter 4. In total, 155 seven- to 11-year old children ($M = 9.63$ years, $SD = 1.07$; 78 males) participated. Children were recruited from the same schools as the previous chapter, in the North East and South West of England and came from four school years: (Year 3: $N = 13$, Year 4: $N = 36$, Year 5: $N = 54$, Year 6: $N = 52$). The mean class size ($N = 13$ school classes) was 27 children (range: 15-35 children per class). Parental consent was obtained for all participants before study participation (see Chapter 3.6 for details of parental consent and ethical approval).

5.2.2 *Social Networks*

Children's social network data was obtained through a technique named social cognitive mapping (SCM; Gest, Farmer, Cairns, & Xie, 2003). SCM involves children acting as informants for a class' social network by naming friendship groups (excluding themselves) from their specific school class. SCM is a particularly useful tool for collecting data on children's social networks, as the triangulation involved in children naming other individuals means it is a more efficient way of gaining network data on the entire classroom than other peer nomination approaches (Neal & Neal, 2013). SCM also avoids potential biases associated with self-reporting of friends, and has been validated in that it positively correlates with observational data of children's affiliative and antagonistic interactions (Gest et al., 2003), as well as teacher ratings and self-report measures (Cappella et al., 2012).

Children were asked to name friendship groups from their school class, excluding themselves. The experimenter asked each child individually, "Can you tell me all the friends, or groups of friends you know from your classroom? Who do you know that hangs around together?" Participants were given as much time as they needed to name as many friendship groups as they liked, and the size of the groups could be anything from two individuals upwards. Individuals could also belong to multiple groups. For example, a participant could identify A and B as friends, and, equally, they could also identify A, C, D, E, F, and H as friends. Ties (connections) were ascribed to individuals named as friends in an aggregated child-by-child classroom matrix. Dyads frequently named as friends were ascribed higher scores (the total number of nominations), while those rarely or never named as friends were ascribed a lower number or no ties. For example, if A and B were named by 12 participants as within a group of friends (which can be the same or different groups across informants), they would be ascribed a score of 12. Equally, if B and C were never named as friends they were ascribed a score of 0.

5.2.3 Tasks

As these children all participated in the previous empirical study, the experimental apparatus (the MMB, the Hook Task and the Alternate Uses test), the procedure administered, and coding structure were identical to that outlined in Chapter 4.2:

All participants

- Whether participants elected for social demonstrations or not (0 coded as social demonstrations, 1 coded as no demonstration).
- The number of successful attempts (max. 10).
- The number of different tools used across all attempts, controlling for their choice of a demonstration or not (max. 4).
- The number of different entrances used across all attempts, controlling for their choice of a demonstration or not (max. 5).
- The number of different exits used across all attempts, controlling for their choice of demonstration or not (max. 6).

Children who elected for demonstrations only

- The number of exact imitations across all attempts; the exact technique (i.e. same tool, entrance and exit) matched to the demonstration (max. 10).
- The number of exit innovations across all attempts; where a different exit than the demonstration was used (max. 10).
- The number of tool innovations across all attempts; where a different tool than the demonstration was used (max. 10).
- The number of entrance innovations across all attempts; where a different entrance than the demonstration was used (max. 10).

- A composite ‘deviation’ score; across all attempts the total number of tool, entrance and exit deviations from the observed method (max. 30).

Children who did not elect for demonstrations only

- The number of different tools used across all attempts (max. 4).
- The number of different entrances used across all attempts (max. 5).
- The number of different exits used across all attempts (max. 6).
- A composite ‘novelty’ score; the total number of different tools, entrances and exits used across all attempts (max. 15).
- The number of repetitions; the total number of times, across all attempts, that an individual repeated a previously used method exactly (max. 9).

Coding for the Hook Task (success/fail and method used) and Alternate Uses task (fluency and originality) matched the previous chapter.

5.2.3 Statistical analysis

Inspection of the data for relationship between learning strategy choices and behaviours on both the Hook Task and Alternate Uses task revealed that the results remained consistent with those found in Chapter 4 (sections 4.3.3 and 4.3.4), with the full cohort of participants. Thus, for brevity these are not reported here (see the above sections for further details). Diagnostic checks suggested no violations of model assumptions, including heteroscedasticity, multicollinearity and so on.

5.2.4 Social network analysis

There are several measures of centrality to analyse individual-level network properties, each representing different aspects of an individual’s network position. Given the findings from previous

work, the current study focussed on betweenness centrality and degree centrality. Betweenness centrality measures the number of times an individual is the bridge along the shortest paths connecting two other individuals. Simply put, betweenness centrality is the act of connecting otherwise unconnected group members. Degree centrality is the number of ties an individual has to others (i.e. nominated friends in their class). These individual level measures give a detailed perspective of an individual's position within their network. Centrality scores were calculated using UCINET (Borgatti et al., 2002) based on the aggregated child-by-child matrices.

Next, node (individual) level analyses were run on these matrices. Node level analyses control for the non-independence of individuals by randomly permuting nodes within their fixed networks. Using this approach, binary and multiple regressions were used to assess whether centrality scores predicted outcomes on the MMB. A binary logistic regression was used to examine whether centrality scores predicted children's choice of asocial or social learning and success on the Hook Task. Multiple regressions were used to assess whether centrality scores predicted the MMB behaviours listed above, the Hook Task methods and performance on the Alternate Uses task, with age and sex included as covariates in all models.

For all regression models computed there was no evidence of multicollinearity (all VIFs < 2.0). To control for familywise errors arising from multiple comparisons I used a false discovery rate (FDR) control (Storey, 2002) set at 10% (see Chapter 3.7) which calculates the expected proportion of false positives (rejection of null hypotheses) from the discoveries. For this the 'families' of tests were selected to reflect the lines of analyses conducted and presented; 1) all participants, 2) those that elected for social demonstrations and 3) those that elected for no demonstrations.

As with Chapter 4, for brevity, I will only describe significant results. For an overview of all results with model beta values, effect sizes and p-values, see Table 5.1. Full details of all regression analyses are provided in Appendix 5.1.

5.3 Results

5.3.1. Multi-methods box

5.3.1.2 All participants

For completeness, I first report the data on the influence of age and sex on learning strategy choices. Analysis confirmed that results from this subset of children mirrored findings from Chapter 4.3.1: Most (57%) children elected for social demonstrations over no demonstrations (43%), females (61%) showed a greater propensity to elect for demonstrations than males (53%, although this was not significant), and children who elected for demonstrations ($M = 9.49$ years, $SD = 1.08$) were younger than children who did not elect for demonstrations ($M = 9.82$, $SD = 1.00$), $p = .039$, although this was not considered significant under the application of the false discovery rate (see Table 5.1).

Did social network positions predict the propensity to elect for social or asocial information?

The binary logistic regression model was a poor fit of the data (Nagelkerke's $R^2 = .055$) and while network centrality measures correctly predicted 78% of those that elected for demonstrations, they only predicted 36% of those who did not. Degree centrality and betweenness centrality did not predict children's learning strategy choice (both $p > .05$, see Table 5.1).

5.3.1.2 Assessing the first attempt

Investigating the first attempt of children who elected for a demonstration directly assesses the influence of social information, because for any subsequent attempt participants have gained personal information.

Thus, in the next section, as with Chapter 4, I examine the fidelity of the first attempts of those who opted for a demonstration to the method observed. For comparison, the performance of those that did not elect for a demonstration on their first attempts was included.

Did children who elected for demonstrations match the observed methods?

As found in Chapter 4, in this subset of children, compared to those who elected for no demonstrations, children who did elect for demonstrations were significantly more likely to fully imitate the demonstration (Fisher's Exact Test [FET], $p < .001$) and to use the same tool (FET $p < .001$), the same entrance (FET $p < .001$) and the same exit (FET $p < .001$) as the demonstration, on their first attempt. Therefore overall, most children who elected for demonstrations were likely to copy the demonstrated methods on their first attempt, while those that selected for no demonstrations rarely exhibited the same techniques as the demonstration.

5.3.1.3 Examining all participants' behaviours on the MMB combined over 10 attempts.

I next assessed the MMB behaviours of all participants combined (i.e. those who both did and did not elect for demonstrations), over their 10 attempts.

Assessment of the influence of learning strategy choice (demonstrations vs no demonstrations) correspond with results of Chapter 4. Learning strategy choice (beta = $-.417$, $p < .001$) significantly predicted the number of successes across all participants (overall $M = 6.76$, $SD = 2.06$); children who witnessed a demonstration ($M = 7.43$, $SD = 1.87$) displayed more successful attempts than those who did not ($M = 5.90$, $SD = 1.99$) over their 10 attempts. Similarly, children who witnessed a demonstration ($M = 2.08$, $SD = 0.86$, beta = $-.379$, $p < .001$) used fewer entrances than those who elected for no demonstration ($M = 3.00$, $SD = 1.21$). Finally, children who witnessed a demonstration ($M = 1.47$, $SD =$

0.92) used fewer exits than those who elected for no demonstration ($M = 2.01$, $SD = 0.90$, $\beta = -.309$, $p < .001$).

Degree centrality ($\beta = -.216$, $p = .041$) significantly negatively predicted the number of successful attempts, although this was not considered significant under the application of the false discovery rate. Degree centrality also positively predicted the number of tools ($M = 2.34$, $SD = 0.91$; $\beta = .302$, $p = .003$) and exits ($\beta = .307$, $p = .002$) children used. Thus, across all participants combined, children with higher degree centrality values used more tools and exits and were marginally less successful than children with lower degree centrality values.

Degree centrality and betweenness centrality did not predict the number of entrances children used, and betweenness centrality did not predict the number successful attempts, the number of MMB tools, entrances or exits, children used (all $p > .05$, see Table 5.1).

5.3.1.4 Assessing those who witnessed a demonstration and those who did not separately (all 10 attempts).

Children who elected for demonstrations.

Within those who elected for demonstrations, degree centrality ($\beta = -.271$, $p = .044$) significantly negatively predicted the number of exact imitations ($M = 3.92$, $SD = 3.15$), although this was not considered significant under the application of the false discovery rate, potentially indicating that children with a higher degree centrality value made fewer exact imitations (i.e., used the same tool, entrance and exit as the demonstration) compared to those with higher degree centrality values. Degree centrality ($\beta = .285$, $p = .034$) also positively predicted both the number of exit innovations ($M = 2.66$, $SD = 2.69$) and children's deviation score ($M = 7.76$, $SD = 5.79$; $\beta = .260$, $p = .049$), although

the latter was not considered significant under the application of the false discovery rate indicating that children with higher degree centrality values were more likely to deviate from the observed methods than those with lower degree centrality scores.

Degree and betweenness centrality scores did not predict the number of tool innovations or the number of entrance innovations. Betweenness centrality also did not predict the number of exact imitations, the number of exit innovations or the children's composite deviation score (all $p > .05$, see Table 5.1).

Children who elected for no demonstration

Of the children who elected for no demonstration, degree centrality (beta = $-.338$, $p = .016$) significantly negatively predicted the number of times children repeated a previously used method ($M = 3.97$, $SD = 2.42$) across their 10 attempts (i.e. used the same tool, entrance and exit as used on a previous attempt). Thus, children with higher degree values were less likely to repeat previously used actions over the 10 MMB attempts.

Degree and betweenness centrality did not predict the number of tools, the number of entrances or the number of exits children who elected for demonstration used, nor did they predict children's composite novelty score. Betweenness centrality did not predict the number of repetitions children exhibited (all $p > .05$, see Table 5.1).

5.3.2 The relationship between social network measures and performance on the Hook Task and Alternate Uses task: all participants.

I next assessed whether social network measures predicted performance on the Hook and Alternate Uses Tasks. The same measures as Chapter 4 (Hook Task: success/failure and the method used, Alternate Uses: originality and fluency) were examined.

Results showed that degree and betweenness centrality did not predict either success or the method used on the Hook Task. Additionally, degree and betweenness centrality did not predict scores of Alternate Uses fluency or originality (all $p > .05$, see Appendix 5.1 for model details, p-values and effect sizes).

Table 5.1: Details of all MMB regression analysis conducted (all participants, children who elected for demonstrations and children who elected for no demonstrations). **Bold type reflects significance at $p < .05$.** +ve denotes significant positive relationships and -ve denotes significant negative relationships. ¹ for binary logistic regressions, Nagelkerke's R^2 is reported.

	Percentage of participants who elected for demonstration					Percentage of participants who elected for no demonstration									
	All Participants	Females	Males	All Participants	Females	Males	All Participants	Females	Males						
	57%	61%	53%	43%	39%	47%									
Regression analyses for all participants						Regression analyses for participants who elected for demonstrations					Regression analyses for participants who elected for no demonstration				
	Learn. strategy $R^2 = .055^1$	Success. attempts $R^2 = .267$	No. of tools $R^2 = .117$	No. of entrances $R^2 = .132$	No. of exits $R^2 = .189$	No. exact imitations $R^2 = .087$	No. tool innovations $R^2 = .044$	No. entrance innovations $R^2 = .028$	No. exit innovations $R^2 = .105$	Deviation score $R^2 = .075$	No. of tools $R^2 = .069$	No. of entrances $R^2 = .020$	No. of exits $R^2 = .043$	Novelty score $R^2 = .043$	No. of repeats $R^2 = .109$
Age		+ve	-ve												
Beta	.372 [^]	.245	-.255	.008	-.018	.177	-.112	-.028	.067	-.051	-.046	.036	-.127	-.051	.111
p-value	.039	.017	.014	.992	.864	.197	.411	.835	.628	.702	.738	.783	.352	.706	.421
Sex															
Beta	-.517	-.077	-.094	-.001	.076	-.090	.017	.003	-.003	.011	-.185	.041	-.068	-.090	.093
p-value	.121	.612	.364	.992	.365	.421	.872	.983	.999	.923	.149	.754	.600	.482	.476
Degree		-ve	+ve		+ve	-ve			+ve	+ve					-ve
Beta	-.014	-.216	.302	.144	.307	-.271	.182	.131	.285	.260	.147	.040	.181	.163	-.338
p-value	.986	.041	.003	.192	.002	.044	.177	.330	.034	.049	.320	.781	.214	.271	.016
Betweenness															
Beta	.001	-.042	.035	-.075	-.051	.188	-.156	-.122	-.006	-.143	.051	-.123	-.124	-.100	.166
p-value	.773	.726	.711	.330	.517	.092	.173	.270	.962	.199	.709	.373	.368	.494	.234

5.4 Discussion

The aim of this study was to examine whether children's social network positions predicted the learning strategies they adopted when individually presented with a novel problem to solve. The predominant finding was that regardless of whether or not children elected for social information before attempting the MMB task, having a greater number of network connections (i.e. more friends) was linked to increased innovative behaviours. Specifically, compared to those with lower degree centrality values, children with many friends who elected for a demonstration showed a greater propensity to deviate from observed methods. Likewise, of the children who elected for no demonstrations, those with many friends tended to be more exploratory by being less likely to repeat previously used actions compared to those with fewer friends. Moreover, across all children combined, those with higher degree centrality values used more distinct tools and entrances on the MMB than children with lower degree centrality values. To my knowledge, these data are the first evidence that children's social network positions shape the learning strategies they adopt, and support findings from adult and nonhuman studies linking network centrality with innovation (Aktamov & Zhao, 2014; Aplin et al., 2012; Baer, 2010; Baer et al., 2015; Claidière et al., 2013).

Prior to this study, the literature had presented two potentially contrasting ways in which network positions influence the use of asocial and social information, with evidence suggesting network centrality facilitates both the use of social information and (asocial) innovation propensity. The present findings support business and nonhuman animal studies indicating that being well-connected in a social group predicts individuals' tendency to engage in innovation (Aplin et al., 2012; Baer, 2010; Baer et al., 2015; Claidière et al., 2013). Theoretical work from industry settings, including with children, suggests that individuals who hold central network positions (and thus have multiple social connections) are exposed to a diverse range of information. In turn, they can synthesise this information to promote

innovation (Baer et al., 2015; Fleming & Waguespack, 2007; Kratzer & Lettl, 2008). This may be particularly evident in friendship (positive) relationships such as examined here; in business settings positive relationships between adults facilitated greater information-sharing through higher trust between individuals (Baer et al., 2015). Therefore, it is possible that the children identified as central (i.e. had many friends) in the present study were more creative and innovative on the MMB because they had more diverse social experiences, particularly with positive associations, allowing them to accumulate a wide range of skills and behaviours from peers. Further, children adjust their copying based on the proficiency of others (Price et al., 2017; L. A. Wood, Kendal, & Flynn, 2015), so it is also plausible that this diverse social experience entailed observations of both proficient and less proficient peers, and in turn, these children were able to then parse these experiences and produce ‘hybrids’ of observed behaviours.

An alternative possibility is that innovativeness and creativity drive popularity. There is some evidence to indicate that creative children are more popular among peers; Newcomb, Bukowski, and Pattee (1993) found that school children reported liking to make friends with peers that are creative and imaginative. In primary-school children in Hong Kong, self-ratings (Lau, Li, & Chu, 2004) peer-ratings (Lau & Li, 1996), and test-performance (Li, Poon, Tong, & Lau, 2013) of creativity correlated with peer and teacher ratings of popularity. Lau et al. (2014) suggested that creative children’s ability to generate valuable and novel ideas (and humour) facilitates popularity among peers. Although there is some evidence that non-western cultures differentially value creativity to western cultures (i.e. non-western cultures are more likely to endorse conformity over creativity; Clegg, Wen, & Legare, 2017), Hong-Kong adults display highly similar learning strategy uses to UK adults (Mesoudi et al., 2014). Accordingly, it is also plausible that the popularity and connectedness of the children here stemmed from their exploratory and innovative nature. Indeed, in Flynn and Whiten (2012), popular children were

also more successful on the puzzle-box, which may suggest they were better problem solvers. While the present study did not examine the directionality of this relationship, future work could do so, perhaps by administering questionnaires to children to elucidate potential reasons for their learning strategy choice (Herrmann, Legare, Harris, & Whitehouse, 2013), or to manipulate affiliative (or non-affiliative) context to examine whether affiliative contexts differentially influence learning strategies in children with varying network positions.

The results contrast with prior child and adult studies reporting popularity and centrality as positively linked to copying propensity (e.g., Christakis & Fowler, 2008; Flynn & Whiten, 2012). One key difference between the current study and these previous ones is that here, children were tested in individual settings (and were required to explicitly choose between social and asocial information) while the previous studies examined individuals in social settings. For instance, Flynn and Whiten (2012) presented children a puzzle box in an open-diffusion group (school class) context, and found popular children copied peers more than less popular children. Given children's strong proclivity to copy others and preference for social information (Carr et al., 2015; Chudek et al., 2016; Flynn et al., 2016; van Leeuwen, Call, et al., 2014; L. A. Wood et al., 2013a) it is perhaps unsurprising that popular children were more likely to observe peers more than less popular children. Their popularity presumably facilitated more frequent exposure to others' behaviours - due to tolerance of their proximity during task interaction (see de Waal, 2001; van Schaik, 2003 for studies on social learning and tolerance in nonhuman primates), and thus more opportunity for copying. By testing children individually, after one-set of demonstrations, this study removed recurring exposure to others' problem-solving behaviours. This approach revealed that over repeated attempts, children identified as having many friends will deviate from witnessed behaviours when interacting individually with puzzle-boxes. In turn, these data

highlight how the dynamics of the social environment (context) during testing also play an important role in children's use of social and asocial information.

In the present study, the social network measures did not predict children's explicit choices of whether or not to receive social demonstrations. These results suggest that while centrality measures used here (i.e. degree centrality) predict children's puzzle-box learning strategies when exposed to social or asocial information, they did not predict children's *explicit* choice to solve novel problems socially or asocially. Moreover, though central children (in terms of degree centrality) were more likely to deviate from observed methods on the MMB, they were not more likely to display tool manufacture (Hook Task) or to generate novel ideas (Alternate Uses Task) than less central individuals. Chapter 4 revealed that children who specifically elected for no demonstrations were more likely to manufacture a hook shape for the Hook Task and generated both more in total, and more original, uses for a paperclip. The findings of this chapter are perhaps not inconsistent with those of Chapter 4. Centrality measures did not predict children's explicit choice of learning strategy and was not correlated with children's performance on a measure of innovation (by-invention) or divergent thinking. In contrast, children's explicit learning strategy choice did show a relationship with performance on the Hook and Alternate Uses task in Chapter 4.

Thus, these findings suggest that while the network measures used here do capture certain aspects of learning strategy use (for example, the propensity to deviate from demonstrations or not to repeat previously used actions) they did not predict other aspects (overt choice of social or asocial information, or performance on innovation-by invention tasks). In turn, these results highlight the importance of considering the experimental design and context when interpreting findings. By offering children the explicit choice of selecting demonstrations or not on a novel multi-method puzzle-box and recording

subsequent behaviours, this study, in addition to Chapter 4, was able to dissociate the potential factors differentiating children who engage in innovation-by-invention and innovation-by-modification.

It is important to acknowledge some limitations of the current study. First, social network data was collected through social cognitive mapping (SCM) – a specific type of peer nomination technique. SCM has several advantages over other peer nomination methods - such as removing desirability bias and, to some extent counters issues with low participation rates (Neal, 2011). SCM is also correlated with several other measures of network data including reports and behavioural measures (Cappella, Kim, Neal, & Jackson, 2013; Gest, 2006; Neal, 2011). However, undoubtedly, peer nomination is a more subjective approach than the types of observational methods used in the nonhuman literature (Krause et al., 2015); children can be unreliable in their peer nomination reports (Poulin & Dishion, 2008). Moreover, peer nomination approaches potentially oversimplify classroom networks by focussing on the presence or absence of relationships, rather than the frequency of interactions or different types of interactions (for example, playing, talking, aggression). Such data would allow investigation of, for example, whether centrally aggressive individuals exhibit the same MMB behaviours as those with central positions based on their positive social interactions. Including observational data of children's social networks would provide a richer dataset in which to explore how individual differences in network positions map on the learning strategy adoption.

Second, the children were tested in an individual setting. Although, as eluded to above, this method provided a new angle to prior findings in social settings (Flynn & Whiten, 2012), examining children in social settings would have provided a more global and in-situ investigation of how children's positions in their social network map on to their innovative propensity (see Chapter 8.5.1.1 for a discussion on individual and social testing). Children's use of social and asocial information in social contexts is likely

to be more dynamic and complex than in the current study. For instance, network data could be used to investigate children's tendency to engage with apparatuses in group settings, rates of copying others in varying positions of social networks, and individual success within groups. The synthesis of systematic social network analysis coupled with natural social conditions promises to be a fruitful avenue for future research.

5.5 Conclusions and implications

Recent work has begun to highlight certain individual-factors that appear to be important predictors of learning strategy use and, as a result, we are now beginning to garner an understanding of individual differences in the use of social and asocial information (Beck et al., 2016; Mesoudi et al., 2016; Muthukrishna et al., 2015; Rawlings et al., 2017). There has, however, also been a striking lack of focus on individual differences in personal social environments when examining learning strategy use - particularly from a developmental perspective. This is a surprising oversight because the social environment, by nature, has a significant impact on the learning strategies individuals can adopt. It is impossible to engage in social learning without interaction with others, while innovation itself can stem from asocial or social bases (Carr et al., 2015; Hopper, 2016; Muthukrishna & Henrich, 2016). By specifically examining children's specific position within the social network of their class, this study highlights both the importance of individual differences in sociality in children's learning strategy use and the need to consider the social context and experimental design in which empirical testing occurs when drawing conclusions.

These findings provide the first evidence that individual differences in children's social network positions are related to the use of social and asocial information, when solving a novel puzzle-box. Children identified by their peers as having more associations (higher degree centrality) within their

school class were more exploratory, more likely to deviate from adult demonstrations and less likely to repeat previously used actions. Coupled with the previous empirical study (Chapter 4) identifying personality as a contributing factor to children's learning strategy choices, these studies move us closer to understanding which individuals are more likely to be those that innovate new behaviours, and which are likely to be those that facilitate their diffusion throughout populations, a topic which will be discussed in the General Discussion (Chapter 8).

Chapter 6 Assessing the stability of chimpanzee personality: A longitudinal approach

The following chapter is to be submitted for publication in *Nature Communications*. The authorship and affiliations are as follows:

Bruce Rawlings¹, Emma Flynn², Hani Freeman³, Lisa Reamer⁴, Lara Wood⁵, Steven Schaprio⁴, Susan Lambeth⁴, & Rachel Kendal¹.

1. Centre for the Coevolution of Biology & Culture, Department of Anthropology, Durham University, UK.
2. Centre for the Coevolution of Biology and Culture, School of Education, Durham University, Durham University, UK
3. Animal Kingdom, Orlando, Florida, USA.
4. National Center for Chimpanzee Care, Michale E. Keeling Center for Comparative Medicine and Research, The University of Texas MD Anderson Cancer Center, Bastrop, TX, USA
5. School of Social and Health Sciences, Abertay University, UK.

Corresponding author: Bruce Rawlings: bruce.rawlings@durham.ac.uk

Abstract

The past decade has seen an emergence of research investigating great ape personality traits analogous to the Big Five observed in humans. A mounting body of studies are showing that these traits may have a wide-ranging influence on the behaviours of nonhuman primates, including performance on various types of cognitive tasks. However, there have been few studies examining the long-term stability of great-ape personality, and most of those that have are cross-sectional studies. Here, we assessed the mean-rank and rank-order stability of chimpanzee personality by collecting ratings for chimpanzees ($N = 50$) and comparing them to ratings collected approximately 10 years previously, using the same six-factor questionnaire which has been validated by observational data. This was, to our knowledge the first longitudinal attempt to measure the stability of chimpanzee personality by comparing ratings on the same instrument. Results showed that overall ratings of three factors differed across the two time points: the chimpanzees were rated as significantly less agreeable and reactive/undependent, while being rated as significantly more dominant. Sex differences in personality were also observed, with males rated as more extraverted and dominant, but less agreeable than females. Further, females displayed increases in agreeableness and openness over the study period, while males decreased in both cases. Rank-order stability data revealed strong stability for dominance; individuals who were dominant at T1 were also dominant 10 years later. Four other traits exhibited moderate-weak rank-order stability and methodical exhibited weak stability, indicating that individuals were variable in their rank-position consistency over the study period. Our findings support and contradict previous cross-sectional chimpanzee studies and show some convergence with patterns of development with human personality trajectory. Further, these data highlight the importance of collecting up-to-date personality data when correlating them with cognitive performance.

6.1 Introduction

The turn of this century saw an unprecedented interest in nonhuman animal personality. Numerous animal species are now known to display consistent individual variation in behaviour across time and contexts. This individual variation is known to have a wide-ranging impact on nonhuman animals, including on fitness and mortality (Dall, Houston, & McNamara, 2004; Dingemanse & Wolf, 2010), cognition (Lermite et al., 2016), reproduction and welfare (Gosling, 2001; McCowan, Rollins, & Griffith, 2014).

Understanding nonhuman animal (hereafter animal) personality also augments our knowledge of the origins of human personality. Empirical studies examining the comparability between animal and human personality afford insights about the evolutionary trajectory of specific personality traits; cross-species similarities likely indicate evolutionarily preserved dispositions (Weiss, King, & Hopkins, 2007).

Chimpanzees' phylogenetic proximity to humans make them a particularly valuable study species for comparative personality research, and factor-based instruments designed to represent those applied to humans have convincingly established that chimpanzees display personality differences in traits analogous to the Big-Five commonly used in humans (Freeman et al., 2013; King & Figueredo, 1997; Weiss et al., 2012, 2011). Moreover, ratings on these factor-based instruments have been shown to predict great ape cognition (Hopper et al., 2014), long-term survival (Weiss, Gartner, Gold, & Stoinski, 2013), sociality (Freeman et al., 2013) and even brain structure (Latzman, Hecht, Freeman, Schapiro, & Hopkins, 2015), providing further support for their validity.

Despite the recent interest in animal personality, one topic that remains understudied - particularly in great apes - is that of personality stability over time. Understanding whether personality remains consistent across the lifespan of great apes allows both researchers to document species-specific

personality maturation, and to make comparisons with the development and stability of human personality. For instance, longitudinal and cross-sectional studies show that as humans age, we display decreases in extraversion and neuroticism, and increases in conscientiousness and agreeableness (Roberts, Walton, & Viechtbauer, 2006; Scollon & Diener, 2006; Srivastava, John, Gosling, & Potter, 2003), with openness to experience appearing to increase in adolescence but then lessen in adulthood (Roberts & DelVecchio, 2000). Cross-sectional studies of great apes reveal patterns of personality development broadly comparable with these human patterns: in chimpanzees, bonobos and gorillas, older individuals are rated as less extraverted than younger individuals (Dutton, 2008; King et al., 2008; Kuhar, Stoinski, Lukas, & Maple, 2006; Staes, Eens, Weiss, & Stevens, 2016). Older chimpanzees and bonobos also show increased agreeableness and decreased assertiveness compared to younger individuals (King et al., 2008; Staes et al., 2016; Weiss & King, 2015). Finally, as with humans, older chimpanzees were also rated as more conscientious and less neurotic than younger chimpanzees (King et al., 2008). This overall comparability with human personality development potentially suggests an evolutionary basis for the human pattern of age-related fluctuations in personality traits (Weiss & King, 2015).

In addition, examining the overall, and trajectory, of sex-differences in nonhuman primate personality also yields insights into our evolutionary past. Recent work has suggested that sex-differences in nonhuman primate development of sociality, learning, foraging and play underpin the biological roots of such human sex differences (Lonsdorf, 2017). As such, comparisons of similarities and differences across sex-groups in nonhuman primate personality permits insights in to the origins of sex differences in human personality (Koski, 2011; Manson & Perry, 2013). For instance, in humans and chimpanzees, females score higher than males on ratings of agreeableness and lower on ratings of dominance, and in both species females become increasingly agreeable with age, while males appear to show no such

change (humans; Srivastava et al., 2003; Weisberg, Deyoung, & Hirsh, 2011, chimpanzees; King et al., 2008; Weiss & King, 2015). There is also some evidence that human females score higher than males on ratings of openness to experience, and that this pattern amplifies over adulthood (Srivastava et al., 2003; Vecchione et al., 2012; Weisberg et al., 2011), though this pattern has not been reported in nonhuman primates. Sex differences in personality are thought to reflect differences in sexual selection (Schmitt, Realo, Voracek, & Allik, 2008) and social factors or life events such as status competition and cooperation (de Waal, 2000; King et al., 2008; Srivastava et al., 2003), as well as sex differences in human cultural norms and social inequality (Brandt & Henry, 2012; Wood & Eagly, 2002). Hence, while further research is needed, the above data potentially suggests some personality traits reflect evolutionary continuity between the two species (Weiss & King, 2015).

Practical and logistical reasons mean that investigation of long-term great ape personality development has been, so far, mostly restricted to cross-sectional studies – including all studies described above. To our knowledge, just two studies have taken a longitudinal approach to measure great ape personality. Recently, over a six- to eight-year period, individual differences in observations of post-conflict consolation behaviours of 44 captive chimpanzees remained moderately consistent (Webb, Romero, Franks, & de Waal, 2017). As individual differences in consolation was not explained by individual variation in general propensity to affiliate with conspecifics, the authors suggested the consistency in post-conflict behaviours might represent stability of empathy (a facet of human agreeableness) in chimpanzees. In another recent study, 24 chimpanzees from Gombe were rated on the Hominoid Personality Questionnaire (HPQ); a nonhuman primate-adapted version of the Big Five plus dominance. These ratings were compared to ratings taken almost 40 years earlier with the same chimpanzees on the Emotions Profile Index (Weiss et al., 2017). Several dimensions were significantly correlated across the two instruments and time periods. For instance, Emotions Profile Index (EPI) ratings of trustful,

aggressive and gregarious were significantly positively correlated with HPQ ratings of agreeableness, neuroticism and extraversion, respectively, while timid and depressed (EPI) were negatively correlated with openness and agreeableness (HPQ), respectively. These correlations suggest convergent validity between different measures and may indicate that some traits such as aggressiveness and gregariousness remained stable over time. However, it is difficult to directly assess the stability of personality traits using different instruments, and this may underlie why some expected correlations did not manifest in this study (i.e. there was not the expected negative correlation between distrustful and agreeableness), and some unexpected correlations did appear (i.e. gregariousness and agreeableness).

Another important reason for establishing personality consistency in nonhuman animals is to assess the reliability of, for logistical reasons, using previously-collected personality data when interpreting experimental findings. Several studies have examined whether great apes' personality predicts cognitive performance using personality data collected (often several) years prior to the measurement of the outcome variable. Such studies have reported a relationship between personality and individual's participation levels on cognitive touchscreen tasks (Altschul et al., 2017; Herrelko et al., 2012), response to inequity (Brosnan et al., 2015), puzzle-box interaction success (Hopper et al., 2014) and interaction with, and success with, tools and tool-use tasks (Massen, Antonides, Arnold, Bionda, & Koski, 2013). These studies undoubtedly highlight the importance of considering personality when drawing conclusions from cognitive experiments in general (Altschul et al., 2017; Morton, Lee, & Buchanan-Smith, 2013). However, without examining how consistent personality traits remain over time within individuals, it remains unclear how representative the original personality data is of the individuals under investigation. Given that cross-sectional findings show factor-based personality traits differ between across age groups, it is likely that individual-level changes also occur.

Broadly, nonhuman animal personality can be measured using behavioural measures and/or trait ratings. Behavioural measures involve observing individuals to systematically quantify individual differences in outward behaviour (e.g., boldness or aggression), while trait ratings rely on knowledgeable humans rating individuals on personality questionnaires comprising a set of predetermined factors (e.g. the HPQ and EPI). Each approach has its own strengths and weaknesses; behavioural observations provide objective, in-situ data of natural or experimentally induced behaviours but can be time consuming to collect and do not control for non-personality factors such as environmental variations. Ratings are logistically quicker and more convenient to collect than observations and do control for variation due to non-personality factors. However, ratings are subjective; two raters may differ on their definitions of traits (for a detailed discussion of the pros and cons of both approaches, see Carter, Marshall, Heinsohn, & Cowlshaw, 2012; Freeman, Gosling, & Schapiro, 2011). In this study we used the six-factor instrument developed by Freeman et al. (2013). This instrument is particularly advantageous because although it relies on human raters, it has been validated by behavioural measures (see the methods section 6.2 for more details).

The present study was a longitudinal assessment of stability of personality in a population of captive chimpanzees. Specifically, human ratings of a six-factor instrument based on the human Big-Five, incorporating agreeableness, dominance, extraversion, methodical, openness and reactivity/undependability, were collated and compared to ratings collected on the same instrument approximately 10 years previously.

There are two main approaches to measure personality consistency over time: mean-level stability and rank-order stability. Mean-level stability measures the extent to which groups of individuals change or remain stable over time on personality dimensions. Rank-order stability reflects the extent to which

groups of individuals maintain similar rank ordering (i.e. ordinal positions) on personality dimensions over time. To assess personality stability at the global and individual levels, we examined both the mean-level and rank-order stability.

The three broad aims of this study are to: 1) Provide longitudinal data to complement the existing cross-sectional work on great ape personality development over time. 2) Grant insights in to how traits change over time at the individual level in chimpanzees, and how this compares to findings from the human literature. 3) Provide clarity on the suitability of drawing conclusions based on personality data collected several years earlier to experimentation. Based on previous cross-sectional studies of great apes' personality stability we made two main predictions:

1. Certain personality traits would show changes over time. Specifically:
 - 1a. Overall, chimpanzees would be rated as more dominant over time (King et al., 2008; Weiss & King, 2015; Weiss et al., 2011).
 - 1b. Overall, chimpanzees would be rated as less extraverted over time (King et al., 2008; Weiss & King, 2015; Weiss et al., 2011)..
2. There would be sex differences in overall ratings and the trajectory of certain personality traits. Specifically:
 - 2a. Males would be rated as more dominant than females (King et al., 2008; Weiss & King, 2015).
 - 2b. Males would be rated as more extraverted than females (King et al., 2008; Weiss & King, 2015).

2c. Females would be rated as more agreeable than males and would show an increase in agreeableness over the time period, while males would show no such increase (King et al., 2008; Weiss & King, 2015).

2d. Females would be rated as higher in openness than males (Weisberg et al., 2011).

6.2 Methods

6.2.1 Subjects

Subjects were 50 chimpanzees (25 males) housed in multiple social groups at the National Center for Chimpanzee Care (hereafter NCCC), Bastrop, Texas, USA. Most chimpanzees were captive born and mother reared and had been housed at the facility for several years. The chimpanzees' personality was rated at two separate time points. First (T1), between April 2006-December 2008 (Freeman et al., 2013), and second (T2) between September 2015-December 2016. At the start of T1, chimpanzees ranged from 5.09- to 37.27-years old ($M = 18.28$ years, $SD = 6.28$), and at the start of T2 the chimpanzees ranged from 14.52- to 45.70-years old ($M = 27.33$ years, $SD = 6.31$).

During the 10-year period, all subjects experienced changes in group dynamics (either new members added, existing members moved to other groups or deceased, and/or a combination of each of these). At T1, group sizes of the study ranged from three- to 14 subjects, whilst at T2 group sizes ranged from eight- to 10 subjects. At T2, subjects were housed with a mean of 4.48 different group members from T1 ($SD = 2.06$, range = one- to eight-different members) and were housed with a mean of 4.55 of the same group members from T1 ($SD = 3.08$, range = 0- to nine- same members).

6.2.2 Materials and Procedure

6.2.2.1 Personality Instrument

Chimpanzees were rated on a 40-item, seven-point Likert scale instrument measuring six overall traits; agreeableness, dominance, extraversion, methodical, openness and reactivity/undependability (Freeman et al., 2013). The scale was generated from data collected on the NCCC chimpanzees across a two-stage process in April 2006-December 2008. First, a broad corpus of descriptors was produced based on chimpanzee ethograms, previous research and expert knowledge. Next, to minimise redundancy, three experts selected 41 (predictable was subsequently removed from the instrument due to low reliability) of the items to comprise the final scale (Table 6.1). The six factors obtained through factor analysis were then validated with behavioural measurements. For example, extraversion predicted affiliative behaviours, openness predicted playful behaviours, and dominance predicted antagonistic behaviours (for a full description of the process, see Freeman et al. 2013).

Table 6.1: The six personality factors with their corresponding facets. (-) denotes negative loadings.

Agreeableness	Dominance	Extraversion	Methodical	Openness	Reactivity/ Undependability
Considerate	Anxious (-)	Active	Methodical	Affectionate/Friendly	Aggressive
Protective	Bold	Affiliative	Self-Caring	Human Orientated	Autistic
	Cautious (-)	Depressed (-)		Inquisitive/Curious	Bullying
	Dependent (-)	Playful		Intelligent	Calm (-)
	Dominant	Sexual		Inventive	Deceptive
	Fearful (-)	Solitary (-)			Defiant
	Relaxed				Eccentric
	Timid				Excitable
					Impulsive
					Irritable
					Jealous
					Manipulative
					Mischievous
					Socially-inept
					Stingy
					Temperamental/Moody

6.2.2.2 *Personality Ratings*

Ratings for both periods were collected during weekly staff meetings. Raters were either carestaff or supervisory staff, all of whom had worked daily with the chimpanzees (cleaning enclosures, feeding and training individual subjects) for at least four months (range: four months-to 21-years, $M = 5.75$ years; $SD = 5.43$). At T1 (April 2006-December 2008), 17 staff rated eight- to 10-chimpanzees each week as part of a study investigating personality in a larger number of the NCCC chimpanzees (Freeman et al., 2013). At T2 (September 2015-December 2016), eight staff rated three- to five-chimpanzees each week (four raters were present at both T1 and T2). The instructions given to the raters were the same at both time periods; raters were instructed to rate chimpanzees based on their overall experience of chimpanzees' typical behaviours and interactions, rather than specific experiences. Raters were instructed not to discuss ratings during or after staff meetings. For an example of the questionnaire administered to raters, see Appendix 6.1.

6.2.3 *Statistical analysis*

We assessed both the mean-level and rank-order consistency over time. We initially report the reliability of ratings for T1 and T2 separately, before reporting the mean-rank and rank-order stability data. To compare the stability of the six factors across the two-time points, overall mean rater scores for each of the six factors were calculated for all individuals (Freeman et al., 2013; Lutzman et al., 2015). To control for familywise errors arising from multiple comparisons, we used a false discovery rate control (Storey, 2002), set at 10% (see Chapter 3.7), which calculates the expected proportion of false positives from all discoveries (rejected null hypotheses). False discovery rate 'families' were selected to match their lines of analyses, such that overall mean-rank stability reflected a family, as did both assessment of sex-differences and rank order stability analysis.

Mean-rank stability was calculated by comparing overall mean scores for each of the six traits at T1 and T2. We first report the main effects of whether each of the six personality factors remained stable or differed between T1 and T2. For each trait, sex differences were also examined by analysing both overall main effects of sex and sex by time interactions. We finish by reporting stability of personality for males and females separately. Mixed effects ANOVAs were conducted; the two time points were the within-subjects independent variable, sex was the between subjects independent variable, and personality ratings was the dependent variable.

To calculate rank-order stability, we first ranked all individuals for each trait at T1 and T2 separately. For instance, an individual who at T1 scored the highest of all individuals for agreeableness but the lowest for extraversion would be ranked 1st (agreeableness) and 50th (extraversion). If at T2 this individual was then ranked the 3rd highest for agreeableness and 42nd highest for extraversion, they would be ranked 3rd (agreeableness) and 42nd (extraversion), respectively. Individuals could have tied ranking positions: if two individuals were tied seventh highest on agreeableness, they were both scored 7.5. We then calculated Spearman's rho correlations to assess the stability in rankings across T1 and T2 (Nogueira, Sechidis, & Brown, 2017; Roostaei, Mohammadi, & Amri, 2014). The following guide was used to interpret rank-order stability correlations (Gauthier, 2001; Mukaka, 2012):

- .00-.19 = very weak correlation;
- .20-.39 = weak correlation;
- .40-.59 = moderate correlation;
- .60-.79 = strong correlation;
- .80-1.0 = very strong correlation.

For further analysis of individual-level stability, we also examined individual differences in ranking positions from T1 to T2, for each factor. Specifically, we directly compared each individual's ranking position at T1 with their position at T2 for each of the six factors. For example, if an individual scored 1st (highest) ranking for agreeableness at T1 and were then rated as 4th highest at T2, they would have a difference of 3 ranking positions for agreeableness. We then calculated both the proportion of individuals who at T2 were ranked within five positions of their ranking at T1, and the mean change in rank-order position from T2-T1. Five ranking positions was selected as it represents 10% of the study population. This allowed a measurement of how closely matched individuals' ranking positions were at T1 and T2 for the six factors.

6.3 Results

6.3.1 Reliability of ratings

Intra-class correlation coefficients (ICCs) were used to measure the association between raters, giving a measure of inter-rater reliability between carestaff ratings of the chimpanzees' personality. Consistent with other studies on nonhuman primate personality (Freeman et al., 2013; Weiss & King, 2015; Weiss et al., 2011), we used the two-way mixed effects calculation for the average measurement from multiple raters (ICC 3,1 and 3,k), where values closer to 1 suggest stronger reliability between raters. At T1, ICCs were largely strong, and all were positive, with most above 0.50 (ICC (3,k) range = 0.35-0.85), suggesting raters generally showed good agreement in ratings (for a detailed description and the analyses of the reliability of ratings for T1, see Freeman et al. [2013]). For T2, ICCs were also generally strong and all were positive, again suggesting good agreement between raters (ICC (3,k) range: 0.35-0.96). See Appendix 6.2 for the intra-class correlation coefficients values for all traits for T1 and T2.

We also calculated the inter-rater reliability of the six personality factors using ICC (3,1) and (3,k). The results for each of the scales are presented with the ICC (3,1) value followed by the (3,k) value: T1 (taken from Freeman et al. 2013): agreeableness (0.37, 0.51), dominance (0.48, 0.64), extraversion (0.48, 0.65), methodical (0.28, 0.36), openness (0.49, 0.63) and reactivity/undependability (0.48, 0.61). For T2, the values were as follows: agreeableness (0.57, 0.72), dominance (0.43, 0.84), extraversion (0.24, 0.61), methodical (0.25, 0.41), openness (0.43, 0.79) and reactivity/undependability (0.37, 0.90). Again, all scores were positive and largely strong, which suggested good agreement between raters at both time points.

6.3.2 Mean-level consistency

6.3.2.1 Main effects over time

Table 6.2 provides a breakdown of the overall mean ratings for the six factors at T1 and T2. Mean ratings of agreeableness $F(1,48) = 6.332, p = .015$ and reactivity/undependability $F(1) = 54.083, p < .001$ decreased significantly overall from T1 to T2. There was also a significant increase in mean ratings of dominance $F(1,48) = 43.834, p < .001$ from T1 to T2. Ratings of extraversion, methodical and openness did not differ between T1 and T2 (all $p > .05$).

Table 6.2: Mean ratings of each of the six factors at T1 (April 2006-December 2008) to T2 (September 2015-December 2016). **Bold type reflects significance.** * denotes significant at $p < .05$, ** denotes significance at $p < .01$ and *** denotes significance at $p < .001$.

Factor	T1 Mean (SD)	T2 Mean (SD)	Difference (T2-T1)
Agreeableness	4.322 (.458)	4.110 (.674)	-.212*
Dominance	4.186 (.592)	4.638 (.755)	+.452***
Extraversion	4.772 (.468)	4.689 (.439)	-.083
Methodical	4.645 (.383)	4.612 (.430)	-.033
Openness	4.725 (.528)	4.746 (.624)	+.021
Reactivity/Undependability	3.903 (.476)	3.333 (.599)	-.570***

6.3.3 Sex differences

To examine whether the trajectory of the factors differed for males and females, and whether the sex groups differed in personality factors overall, we looked at main effects of sex, time by sex interactions and where appropriate, within-sex effects for each factor. For mean ratings of each of the six factors across time points and sex groups, see Table 6.3.

While overall ratings of agreeableness decreased (shown in Table 6.2), across the two time points combined, males ($M = 4.02$, $SD = 0.62$) were rated as significantly less agreeable than females ($M = 4.42$, $SD = 0.62$), $F(1, 48) = 10.632$, $p = .002$. There was also a significant interaction between time and sex (Figure 6.1); males exhibited a decrease of 0.48 and females displayed a slight increase of 0.05, $F(1, 48) = 9.774$, $p = .003$. The decrease in male agreeableness from T1 to T2 was significant $F(1, 24) = 20.413$, $p < .001$. Ratings of female agreeableness from T1 to T2 did not differ ($p > .05$).

Dominance increased overall (Table 6.2). Across the two time periods combined, males ($M = 4.72$, $SD = 0.78$) were rated as more dominant than females ($M = 4.10$, $SD = .078$), $F(1, 48) = 9.738$, $p < .001$.

There was no significant interaction between time and sex ($p > .05$); both male and female ratings of dominance increased significantly from T1 to T2, (males: $F(1, 24) = 57.227, p < .001$; females: $F(1, 24) = 10.116, p = .004$), see Table 6.3.

For extraversion, overall males ($M = 4.89, SD = 0.52$) were rated as more extraverted than females ($M = 4.57, SD = 0.52$), $F(1, 48) = 9.530, p = .003$, across the two time periods combined. There was no significant sex by time interaction effect, nor did male or female ratings of extraversion differ between T1 and T2 (all $p > .05$).

Similarly, as expected, for methodical, which did not differ overall, there was no main or interaction effects, nor did male or female ratings differ between T1 and T2 (all $p > .05$).

Openness also did not differ overall (Table 6.2) and there were no main effects of sex ($p > .05$).

However, there was a significant sex by time interaction (Figure 6.1); males exhibited a decrease of 0.16 and females exhibited an increase of 0.20, $F(1, 48) = 4.674, p = .036$. The decrease in male openness from T1 to T2 approached significance $F(1, 24) = 4.023, p = .056$, while the increase in female openness was not significant ($p > .05$).

Finally, for reactivity/undependability, which decreased overall (Table 6.2) there was no sex by time interaction, but the main effect of sex approached significance, $F(1, 48) = 3.943, p = .053$, with males ($M = 3.76, SD = 0.64$) rated as higher in reactivity/undependability than females ($M = 3.49, SD = 0.64$). Ratings of male reactivity/undependability decreased significantly from T1 to T2, $F(1, 24) = 24.462, p < .001$. Equally, ratings of female reactivity/undependability decreased significantly from T1 to T2, $F(1, 24) = 32.135, p < .001$.

Table 6.3: Mean ratings of each of the six factors at T1 (April 2006-December 2008) and T2 (September 2015-December 2016), for males and females.

Factor	Males		Females	
	T1 Mean (SD)	T2 Mean (SD)	T1 Mean (SD)	T2 Mean (SD)
Agreeableness	4.254 (.437)	3.777 (.527)	4.391 (.480)	4.442 (.648)
Dominance	4.458 (.531)	4.990 (.508)	3.914 (.529)	4.287 (.804)
Extraversion	4.932 (.418)	4.850 (.422)	4.611 (.468)	4.528 (.401)
Methodical	4.634 (.436)	4.533 (.427)	4.656 (.330)	4.703 (.424)
Openness	4.812 (.524)	4.649 (.648)	4.640 (.529)	4.843 (.597)
Reactivity/Undependability	4.008 (.428)	3.480 (.572)	3.799 (.507)	3.180 (.599)

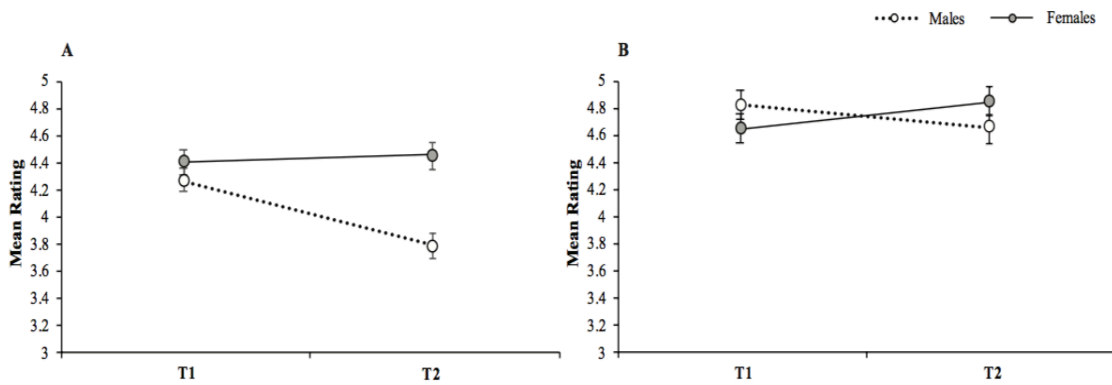

Figure 6.1: Results revealed significant sex by time interactions for agreeableness (A) and openness (B).

6.3.4 Rank-order stability

Table 6.4 provides a summary of the rank-order measures for each of the six factors; the correlation coefficients (Spearman's rho), the number and proportion of subjects remaining within five ranking positions, and the mean change in rank-order position, across the two time points. All factors showed moderate to strong correlation coefficients, with dominance ($r_s = .783$) showing the highest rank-order stability and methodical ($r_s = .371$) showing the lowest rank-order stability. This was supported by results of individual consistencies in ranking positions. Dominance showed the strongest stability, with 56% ($N = 28$) of individuals rated at T2 as within five ordinal ranking positions of their original position

at T1 (mean change in ranking position = 6.98, $SD = 6.52$). Methodical showed the least individual consistency, with 24% ($N = 12$) of individuals rated at T2 as within five ranking positions of their position at T1 (mean change in ranking position = 12.72, $SD = 10.09$).

Table 6.4: Rank-order stability correlation coefficients (Spearman's ρ), and a breakdown of the individual level changes in ranking positions between T1 and T2, for the six personality factors. *denotes significance at $p < .05$, **denotes significance at $p < .01$ and ***denotes significance at $p < .001$.

Factor	Rank-order stability; r_s	No. of individuals within 5 ranking positions (/50)	Percentage of individuals within 5 ranking positions	Mean change in ranking position (SD)
Dominance	.783***	28	56.0	6.98 (6.52)
Reactivity/Undependability	.507***	20	40.0	10.76 (9.56)
Extraversion	.506***	12	24.0	11.24 (8.99)
Openness	.477***	14	28.0	10.82 (10.14)
Agreeableness	.419**	14	28.0	11.50 (10.57)
Methodical	.371**	12	24.0	12.72 (10.09)

$p < .05$ *; $p < .01$ **; $p < .001$ ***

6.4 Discussion

This study is, to our knowledge, the first to examine the stability of multiple chimpanzee personality traits by measuring changes in traits across two long-term time points using the same instrument. The two approaches to measure stability revealed consistencies and differences with previous cross-sectional work. Analysis of mean-rank stability revealed that, consistent with previous findings, overall, chimpanzees showed increased dominance with age, and sex differences in extraversion and agreeableness, with males rated higher in the former and females rated higher in the latter. The chimpanzees were also rated as significantly less reactive/undependent over time overall, with females also scoring lower than males on this trait. However, analysis of sex differences in the trajectory of traits showed that males and females differed for agreeableness and openness, with females increasing and

males decreasing in both cases – the former finding not previously reported. Further, in contrast to other cross-sectional findings, over time the chimpanzees were rated as less agreeable - though this decrease was driven by males. Investigation of rank-order stability revealed strong stability for dominance; individuals who were dominant at T1 were also dominant ten years later. The other five traits exhibited moderate-low rank-order stability, indicating that individuals were variable in their ordinal rank-position consistency over the study period.

Personality development in both humans and chimpanzees is thought to reflect sexual selection pressures and, at least in part, social factors or life events (King et al., 2008; Srivastava et al., 2003). For instance, social species such as chimpanzees face many important socially-related issues including status competition, hierarchical conflicts and cooperation, and in fission-fusion societies these events are often dynamic in nature. That males are more dominant and extraverted but less agreeable than females is thought to reflect the fact that males invest more effort to increase their social status, while investing relatively little in their offspring (Weiss & King, 2015). This corresponds with several findings that human males are rated as more assertive, risk-prone, active and less considerate and affiliative than females (Chapman, Duberstein, Sørensen, & Lyness, 2007; Costa, Terracciano, & McCrae, 2001; Weisberg et al., 2011). Additionally, chimpanzees here were rated as less reactive/undependent over time. While this trait is specific to the instrument used in this study, it incorporated several facets of neuroticism as measured in humans (jealously, manipulative, excitable, temperamental, calm – negatively loaded) and thus could potentially be seen as convergent with findings that humans decline in neuroticism with age (Roberts & DelVecchio, 2000; Srivastava et al., 2003) – though further work would be needed to verify this suggestion.

The results also revealed sex differences in personality traits that contrast with previous chimpanzee studies but that are in line with findings from the human literature. For instance, King et al. (2008) found that chimpanzees decline in openness with age, whereas in the present study, while males significantly declined in openness, females increased by a similar margin. Although these findings contrast with those of King and colleagues, they are consistent with some findings that human females score higher on openness to experience than males (Weisberg et al., 2011) and that this pattern continues throughout development (Gjerde & Cardilla, 2009). In humans, females score particularly high on the facets of openness to experience encompassing warmth, feelings and aesthetics. One potential explanation for the contrasting findings between this study and that of King et al. (2008) is the present study included affectionate/friendly as a measure of openness, and thus could contribute to the sex-differences found here. Indeed, in both humans and chimpanzees, females score higher on traits relating to affection and gregariousness (Costa et al., 2001; Weisberg et al., 2011; Weiss et al., 2011). In unison, the findings here comparable with human personality development supports other studies suggests an evolutionary basis for the human fluctuations in personality traits (King & Figueredo, 1997; King et al., 2008; Weiss & King, 2015).

Dominance showed the strongest rank-order consistency, indicating that individuals that were dominant at T1 were generally dominant at T2; at T2 over half of subjects were within five ranking positions (i.e. 10% of the study sample) of their position at T1. This finding was perhaps expected: chimpanzees exhibit a strongly linear dominance hierarchy and acquire dominant-subordinate relationships from a young age (Markham, Lonsdorf, Pusey, & Murray, 2015). Further, a strong rank-order consistency for dominance has also been reported in other nonhuman primate species, such as macaques (Balasubramaniam et al., 2013). All other traits, except methodical (which showed weak consistency), showed moderate rank-order consistency, indicating that individuals were variable in their rank-position

consistency. Under half of subjects remained within five ranking positions from T1 to T2 for agreeableness, extraversion, openness and reactivity/undependability, suggesting that individuals became significantly higher or lower in these traits over time. That methodical displayed the least rank-order consistency is not surprising. In the initial study by Freeman et al. (2013), methodical showed the least reliability and failed to correlate with factors from other instruments measuring chimpanzee personality.

The fact that for several traits, there were both overall and sex-differences and variable individual-level consistency, highlights the need to complement existing cross-sectional great ape personality-stability work with longitudinal data. Longitudinal data is logistically difficult to obtain, requiring a substantial research effort and does not control for events occurring during the data collection period. In contrast, cross-sectional data is simpler to collect and doesn't face the issue of potential events during data collection. However, longitudinal studies are highly effective at measuring development over time at the group level, and importantly, long-term comparisons also allow assessment at the individual level, not permitted by cross-sectional data. The data here revealed group differences in personality trajectory not previously captured by cross-sectional findings and revealed much individual-level variability in personality trait stability.

Moreover, these findings have implications for the use of personality ratings obtained at a different time to empirical tests. For example, much recent work has highlighted the importance of openness in chimpanzee problem solving, participation and success (Altschul et al., 2017; Herrelko et al., 2012; Hopper et al., 2014) and performance on inequity tasks (Brosnan et al., 2015). These studies relied on the personality ratings collected several years prior to the cognitive testing sessions. Here, we found that males significantly decreased in openness over several years, while female ratings increased by a similar

(but nonsignificant) margin, and, perhaps more importantly that only 28% of individuals remained in a close ranking position (10% of the sample) over the time period. This may suggest, depending on the timeframe between rating collection and experimental testing - that the personality ratings may not completely accurately reflect the individuals at the time of study participation. Thus, we encourage that where possible, authors use or collect recent personality data when conducting personality-based assessments of cognitive performance or other empirical measurements, or researchers take this in to consideration when drawing conclusions from assessment of whether personality data predicts cognitive measures.

It is also important to consider other potential explanations for the differences found here compared to previous work on chimpanzee personality development. For example, it is possible that the differences in findings may reflect the different scales used across different studies. Here, we used a six-factor scale based on, but not identical to the human Big Five scales. Previous studies have used different five or six-factor scales with factors identical (plus dominance for the latter) to the human Big Five (King et al., 2008; Weiss et al., 2007, 2011). However, despite some differences between the instrument used here and others, there is also large overlap. For example, four of the factors included here (agreeableness, extraversion, openness and dominance) are the same factors as used in the previous studies above, and the specific loadings are also highly similar. Indeed, excluding methodical, the factors used on the scale in this study correlated strongly with those used in other studies (Freeman et al., 2013). As such, we believe the differences in instruments used in this study is unlikely fully account for the differences found compared to previous cross-sectional studies.

It is also possible that external factors such as location or group demographics play a role. Weiss et al. (2007) found some differences (as well as consistencies) in personality ratings when comparing

chimpanzees from laboratory and zoo settings. Factors such as group demographics, the level of enrichment and human interaction (and human-animal relationships) likely vary across settings, which may manifest in differences in ratings of personality stability over time. As such, caution should be exercised when generalising findings to animals in other locations (also see Leavens, Bard, & Hopkins, 2010).

Moreover, all study subjects experienced changes in group members and group sizes across the study period, and many experienced relocations to new enclosures (on-site). Personality has been shown to correlate with individual differences to stress response in young chimpanzees (Anestis, Bribiescas, & Hasselschwert, 2006), and it has been found that in chimpanzees, squirrel monkeys and capuchins, social dynamics including individual and group level affiliative and aggressive behaviours are disrupted by enclosure relocation and changes to group demographics (Dufour, Sueur, Whiten, & Buchanan-Smith, 2011; Schel et al., 2013), but that such behaviours begin to normalise after a year (Schel et al., 2013; Yamanashi et al., 2016). Given there were no major alterations to group demographics or relocations for the study subjects for several years prior to the second data collection period, it is unclear whether the effects of relocation had a major bearing on ratings.

The aim of this study was to provide much needed longitudinal data examining the stability of group and individual-level chimpanzee personality factors. By comparing personality ratings approximately 10-years apart, results revealed that overall the chimpanzees here were rated as more dominant, but less agreeable and reactive/undependent at the second-time point. Both sexes increased in dominance, males became less agreeable and open, while females displayed the opposite pattern. Finally, across the 10-year period, individuals initially rated as dominant were also rated as dominant 10-years later, with the other traits showing moderate or weak individual-level consistency. This study thus captured age and

sex differences in chimpanzee personality not seen in previous cross-sectional work. Accordingly, we suggest that where possible, researchers interested in measuring the relationship between personality and cognitive performance in nonhuman primates obtain up to date personality data.

Chapter 7: Individual differences in chimpanzee learning strategy

behaviour: Assessing the role of personality

Dr. Lisa Reamer, Behavioural Research Coordinator at the NCCC (where the chimpanzee data was collected), assisted with data collection throughout this study, and will have authorship on any subsequent published article(s) from this chapter.

Abstract

Chimpanzees, arguably humans' closest cultural relatives, exhibit among the most diverse array of population-specific behaviours within the animal kingdom. As with humans, this group level variation is maintained by both innovation and social learning. Despite their importance for cultural evolution, within-species inter-individual variation in asocial and social information use (learning strategies) remains poorly understood, particularly in chimpanzees. This study aimed to assess individual differences in chimpanzee learning strategy use by assessing whether personality is a contributing factor in chimpanzee learning strategy use.

Across two studies, chimpanzees ($N = 49$) were presented with two distinct types of multi-action puzzle-boxes and exposed to two experimentally induced types of social information - video demonstrations and live human demonstrations - as well as being able to observe conspecifics during group testing sessions. Learning strategy behaviours were associated with personality data collated by collecting carestaff ratings on a six-factor instrument.

Results revealed that although there was tentative evidence that dominance predicted the propensity to observe video demonstrations (Experiment 1), personality ratings did not predict subjects' propensity to

observe live human demonstrations or observations of conspecifics during task interaction. Moreover, chimpanzees largely appeared to rely on individual rather than social information; while there was potential evidence that video demonstrations influenced chimpanzee puzzle-box behaviours, there was no effect of human demonstrations or observations of conspecifics successful behaviours and in both experiments, there was no difference between the puzzle-box behaviours of the control and experimental subjects. However, sex differences in learning strategy behaviours were observed. When an asocial and social (offering live human demonstrations) puzzle-box were simultaneously presented (Experiment 2), while most chimpanzees interacted with the asocial puzzle-box before observing a human demonstration, males were more likely to do so than females. In contrast, over the course of the testing sessions, females were more likely to observe the demonstrations. Finally, there were also cross-experiment consistencies in the propensity to use the various types of information; observations of video demonstrations (Experiment 1) were correlated with observations of human demonstrations (Experiment 2), as was the propensity to observe conspecifics during task interaction across both experiments. These data largely contradict previous work highlighting the role that personality plays in learning strategy use in humans and other nonhuman animal species, but they provide the first evidence, to my knowledge of cross-task consistency in chimpanzee social information use.

7.1 Introduction

Decades of research has now robustly established that chimpanzees exhibit among the most diverse array of population-specific behaviours within the animal kingdom (Whiten, 2017b; Whiten et al., 1999). Chimpanzees display group level variation – most likely not attributable to ecological or genetic factors - in the domains of foraging with tools (Gruber et al., 2009; Hobaiter et al., 2014; Luncz & Boesch, 2014) and without tools (Rawlings et al., 2014), communication (Tomasello et al., 1997), social interactions (Bonnie & de Waal, 2006; van Leeuwen et al., 2012), and even arbitrary behaviours (such as putting grass in ears; van Leeuwen, Cronin, & Haun, 2014). As with humans, this diversity is maintained through a combination of social transmission and innovation. Innovations introduce behavioural variants within populations, and social learning underpins their diffusion across group members (Goodall, 1986; Hobaiter et al., 2014; van Leeuwen, Cronin, et al., 2014). As such, chimpanzees have been labelled human's closest cultural cousins (Gross, 2016).

Chimpanzees' complex social dynamics, and cultural and phylogenetic similarity to humans means they are an ideal species for comparative cultural evolution research (Whiten, 2017b; Whiten et al., 2009). Chimpanzees share many similarities with children over a range of learning strategy behaviours, yet also markedly differ in other aspects (see Dean, Vale, Laland, Flynn, & Kendal, 2014; Price et al., 2017; Whiten, 2017; Whiten et al., 2009 and Chapter 2 for detailed discussions of the similarities and differences between children and chimpanzees' learning strategy behaviours). Pertinent to this thesis, a key difference between chimpanzees and humans appears to be their relative reliance on social and asocial information. Chimpanzees, in contrast to children, appear to primarily rely on personal, individually obtained information. For instance, when exposed to conflicting individual and social information on a reward retrieval task, chimpanzees showed a significantly greater reliance on individual information than children, who were more likely to use the social information (van Leeuwen,

Call, et al., 2014). Similarly, in a token exchange task, children were more likely to adjust their behaviours based on social information than chimpanzees, who displayed minimal evidence of social information use (Vale, Flynn, et al., 2017). This difference in learning strategy use may partly explain the differences in cultural complexity between humans and chimpanzees (van Leeuwen, Call, et al., 2014).

Owing to the importance of innovation and social learning for animal cultural traditions, researchers have recently begun to examine individual differences in the use of specific learning strategies. The principle aim of these endeavours is to enhance our knowledge of how cultural traditions emerge and establish across the animal kingdom, by understanding underlying factors differentiating innovators from social learners. Indeed, a mounting body of animal studies indicate that, within species, individuals consistently differ in the propensity to engage in social learning and innovation. The range of factors that appear to play a role are diverse; there is evidence – albeit often equivocal – that characteristics such as age, sex, social rank and physiological states (such as reproductive state) impact the use of animal social and asocial information (for a review of individual differences in animal learning strategy use, see Mesoudi, Chang, Dall, & Thornton, 2016 and Chapter 2).

Increasingly, personality appears to be a particularly important factor in individual differences in the use of social and asocial information. Recent developments in the field of animal personality have improved our understanding of how individual variation in personality predicts individual variation in problem solving and cognition (Altschul et al., 2017; Griffin & Guez, 2014; Guillette et al., 2017). Subsequently, across a diverse range of taxa, personality traits have also been established as reliable correlates of the use, and related success, of specific learning strategies (Carter, Marshall, Heinsohn, & Cowlshaw, 2013; Guillette et al., 2017; Hopper et al., 2014; Nawroth, Prentice, & McElligott, 2016, Chapter 2). The

most widely studied axes of personality in the animal literature are that of boldness-shyness and relatedly, neophobia-neophilia. Bolder individuals are more gregarious and risk-taking and conversely, shyer individuals tend to be less gregarious and more risk averse. Similarly, neophobic individuals are risk- and novelty-averse while neophilic are quick to explore and approach novelty. These axes are generally measured through behavioural assays, by recording individuals' behaviours in response to novel objects or environments (Carter, Feeney, et al., 2013).

Both the boldness-shyness and neophobia-neophilia axes appear to be important predictors of learning strategy use, although findings are contradictory. For instance, studies of several species have shown that bolder and neophilic individuals are more likely to use social information. In studies of baboons (Carter et al., 2014), great tits (Marchetti & Drent, 2000), guppies (Trompf & Brown, 2014), and nine-spined sticklebacks⁴ (Nomakuchi et al., 2009), boldness positively predicted social information use on novel foraging tasks. In some species bolder individuals have higher levels of social interactions than shyer individuals (e.g. spiders, Keiser et al., 2016; three-spined sticklebacks, Pike, Samanta, Lindström, & Royle, 2008) and show a greater attraction to social stimuli (three-spined sticklebacks, Jolles et al., 2015). This may suggest that bolder individuals experience more exposure to conspecifics' behaviours (and thus to social information) through increased social interaction.

By contrast, however, there is also evidence indicating that boldness is negatively correlated with social information use. Bolder zebra finches⁴ were less likely to use social information in experimentally induced mating and foraging contexts (Rosa et al., 2012), while bolder great tits tend to forage at the periphery of a flock (i.e. away from most individuals) than less bold individuals (Aplin et al., 2014), and

⁴ In these studies, the personality trait correlated with social information use was fast-exploration. Fast exploration encompasses being active, aggressive and fast to explore novel environments, and strongly correlates with measures of boldness (Sih et al., 2014).

finally, shy barnacle geese were more likely to use social information on a food-location task than bolder individuals (Kurvers, van Oers, et al., 2010). One potential explanation for these seemingly inconsistent findings is that shy and more fearful individuals tend to stay close to conspecifics (Michelena et al., 2010), particularly in novel contexts (Burns, Herbert-Read, Morrell, & Ward, 2012) - which presumably includes experimental conditions. Consequently, shy individuals may obtain social information as a function of proximity to others in such situations (Kurvers, van Oers, et al., 2010) while bolder individuals may acquire social information through actively seeking social interactions (Jolles et al., 2015; Kurvers, Prins, et al., 2010).

In terms of (asocial) innovation, theoretical and empirical work suggests that the neophobia-neophilia axis is an important predictor of inter-individual variation in innovative behaviours. Across species, neophobic individuals exhibit a lower propensity to display innovation and exploration on extractive foraging tasks (spotted hyenas; Benson-Amram & Holekamp, 2012, callitrichids; Day, Coe, Kendal, & Laland, 2003, carib grackles; Overington, Cauchard, Côté, & Lefebvre, 2011, corvids; Stöwe et al., 2006). By being less likely to explore novel situations and objects, and less likely to exploit new food types, neophobic individuals face few innovation opportunities (Call 2015). In contrast, neophilic individuals show a greater attraction to novel situations, and thus exhibit a greater propensity to innovate and better performances on individual innovation tasks (callitrichids; Day et al., 2003, Panamanian bishop fish; DePasquale, Wagner, Archard, Ferguson, & Braithwaite, 2014; black-capped chickadees; Guillette, Baron, Sturdy, & Spetch, 2016). By actively engaging in novel contexts, neophilic individuals experience more opportunities requiring innovation and novel problem solving and thus have more chances to generate such solutions (Tebbich et al., 2016).

While these studies are essential for understanding differences in learning strategy use at the individual and species level, the diversity of methodological approaches used to assess personality and learning strategies means direct cross-species comparison remains difficult. The study of personality in nonhuman animals has excelled in recent years, however, providing promising techniques for cross-species comparisons. There has been particular focus on human-nonhuman great ape comparisons of personality, and various factor-based personality instruments have been developed comparable to those used for humans, allowing direct personality comparisons between species (King, Weiss, & Sisco, 2008; Staes, Eens, Weiss, & Stevens, 2016; Weiss & King, 2015, and see Chapters 2.6.3 and 6 for discussions of such developments). Further, such instruments can be used to assess the similarities and differences personality plays in humans, nonhuman great apes and other nonhuman animals' learning strategy use. To my knowledge, just one study has taken this approach, finding that human ratings of openness, reactivity/undependability, and dominance (which incorporates boldness) predicted duration of puzzle-box interaction in chimpanzees (Hopper et al., 2014). This finding offers an important but tentative basis for comparisons with human and animal research. For instance, in addition to the studies outlined above reporting links between boldness and learning strategies, work with human children and adults has shown inter-personal traits such as extraversion and agreeableness predict social information use while traits such as openness to experience and conscientiousness predict socially- and asocially-mediated innovation (Rawlings, Flynn, & Kendal, 2017, Chapter 4).

The objective of the current study was to investigate whether personality predicts the learning strategies chimpanzees adopt when solving novel puzzle-boxes. Across two experiments, chimpanzees were presented with two types of social information (video demonstrations and human demonstrations, each in separate experiments), as well as being able to freely observe conspecifics during task interaction. Learning strategies were assessed with novel four-action puzzle-boxes (see Chapter 3.3 for a discussion

of the benefits of multi-action puzzle-boxes) in natural group settings. Personality ratings were investigated to determine whether they correlated with the propensity to engage in asocial and social information use. This study will provide both novel insights into whether personality predicts chimpanzee learning strategy behaviours and a point of comparison with the corresponding empirical study conducted with children (Chapter 4), which found that certain personality traits (conscientiousness, openness to experience) predicted innovative propensity, while others (agreeableness) predicted the propensity to elect for social information when faced with a novel problem.

Based on empirical studies suggesting a positive (e.g., Carter et al., 2014; Marchetti & Drent, 2000) and negative (e.g., Kurvers, van Oers, et al., 2010; Rosa et al., 2012) relationship between boldness (and related traits) and social information use, and that openness is linked to asocial problem solving behaviours I made two main alternative predictions.

1. Dominance, which incorporates boldness, would be related to learning strategy use in one of two ways:
 - a. Dominance would be positively correlated with social information use (Carter et al., 2014; Hopper et al., 2014; Marchetti & Drent, 2000).
 - b. Dominance would be negatively correlated with social information use (Kurvers, Prins, et al., 2010).
2. Openness would be positively correlated with asocial innovation (Hopper et al., 2014; Rawlings et al., 2017).

7.2 Experiment 1: Method

7.2.1 Subjects

Test subjects were forty-nine chimpanzees ($M = 27.71$ years, $SD = 6.28$; males = 23) comprising six multi-male-multi-female social groups (group size range: six- to 10-chimpanzees). Control subjects were from two groups, both comprising eight individuals ($N = 16$, six males). The mean age was 23.94 years ($SD = 5.40$).

Subjects were housed at the National Center for Chimpanzee Care (NCCC) in Bastrop, Texas. The NCCC is fully accredited by the Association for Assessment and Accreditation of Laboratory Animal Care International. Most chimpanzees were born in captivity and mother-raised. All subjects that participated in the experiments (including control subjects) were housed in hexagonal corrals. The outdoor areas of the corrals measured approximately 3400 square feet and were enriched with a range of climbing frames, nettings, ropes and tunnels.

The study was approved by the Animal Welfare Ethical Review Board (AWERB), Durham University, Durham, England, and the Institutional Animal Care and Use Committee of The University of Texas M. D. Anderson Cancer Center. Participation was entirely voluntary and involved no separation of individuals, and no food or water deprivation.

7.2.2 Materials

7.2.2.1 Personality Instrument

Chimpanzees were rated on a 40-item, seven-point Likert scale instrument measuring six overall traits; agreeableness, dominance, extraversion, methodical, openness and reactivity/undependability (Freeman et al., 2013). The scale was generated from data collected on the NCCC chimpanzees across a two-stage

process. First, a broad corpus of descriptors was produced based on chimpanzee ethograms, previous research and expert knowledge. Next, to minimise redundancy, three experts selected 41 (‘persistent’ was subsequently removed from the item-pool) of the items to comprise the final scale (Table 7.1). The six factors obtained through factor analysis were then validated with behavioural measurements. For example, extraversion predicted affiliative behaviours, openness predicted playful behaviours, and dominance predicted antagonistic behaviours (for a full description of the process, see Freeman et al. 2013). Previously, this scale has been used to investigate correlations with chimpanzee asocial problem solving (Hopper et al. 2014) and inequity responses (Brosnan et al., 2015).

Table 7.1: *The six personality factors with their corresponding facets. (-) denotes negative loadings.*

Agreeableness	Dominance	Extraversion	Methodical	Openness	Reactivity/ Undependability
Considerate	Anxious (-)	Active	Methodical	Affectionate/Friendly	Aggressive
Protective	Bold	Affiliative	Self-Caring	Human Orientated	Autistic
	Cautious (-)	Depressed (-)		Inquisitive/Curious	Bullying
	Dependent (-)	Playful		Intelligent	Calm (-)
	Dominant	Sexual		Inventive	Deceptive
	Fearful (-)	Solitary (-)			Defiant
	Relaxed				Eccentric
	Timid				Excitable
					Impulsive
					Irritable
					Jealous
					Manipulative
					Mischievous
					Socially-inept
					Stingy
					Temperamental/Moody

7.2.2.2 Personality Ratings

Ratings were collected during weekly staff meetings from September 2015-December 2016. Raters were either care staff or supervisory staff, all of whom had worked daily with the chimpanzees (cleaning enclosures, feeding and training individual subjects) for at least four months (range: 6 months- to 10-years, $M = 5.56$ years; $SD = 3.64$). Eight staff rated three- to five-chimpanzees at the weekly meetings. Raters were instructed to rate chimpanzees based on their overall experience of chimpanzees' typical behaviours and interactions, rather than specific experiences. Raters were instructed not to discuss ratings during or after staff meetings.

7.2.2.3 Puzzle-box

The puzzle-box (termed 'Lazy-Alpha') comprised a square box, 52.5cm x 52.5cm x 52.5cm, which could freely spin around 360 degrees on a vertical axis mounted upon a horizontal spinning disc (Figure 7.1A). On each of the four sides of the box was a door (30cm x 19cm) that could be opened by gripping a handle and sliding the door in a specific direction. The directions of all four of the doors combined comprised an 'X' shape, where side A slides up-left, side B slides up-right, Side C slides down-left and Side D slides down-right (see Figure 7.1A). Each 'side' of the box was fitted with internal self-baiting dispensers (plastic chutes), that could be stocked with approximately 20 cherry tomatoes, giving an approximate total of 80 cherry tomatoes per puzzle-box. When a door was opened, chimpanzees received a cherry tomato as a reward. The puzzle-box was manufactured so that when a door shut after being opened, it would simultaneously distribute and auto-rebait (similar to a 'PEZ' candy dispenser, Figure 7.1B). For the up-left and up-right doors, gravity would bring the doors shut when no pressure was being exerted on them. For the down-left and down-right doors, counter-weights were tied to the doors to bring them down when no pressure was being exerted on them. To improve discrimination

between the four sides, each door was marked with a different colour and pattern (Blue Spotted, Red Stripes, Black Stripes and Green Chequered patterns). These colours were selected to be clearly distinguishable to chimpanzees (who exhibit trichromacy vision), and colour-pattern designs were randomly chosen. Two identical versions of the ‘Lazy-Alpha’ were simultaneously presented to the chimpanzee groups (Figure 7.2), to reduce the issues in data interpretation when dominant individuals monopolise apparatus (Cronin et al., 2017; van de Waal et al., 2014).

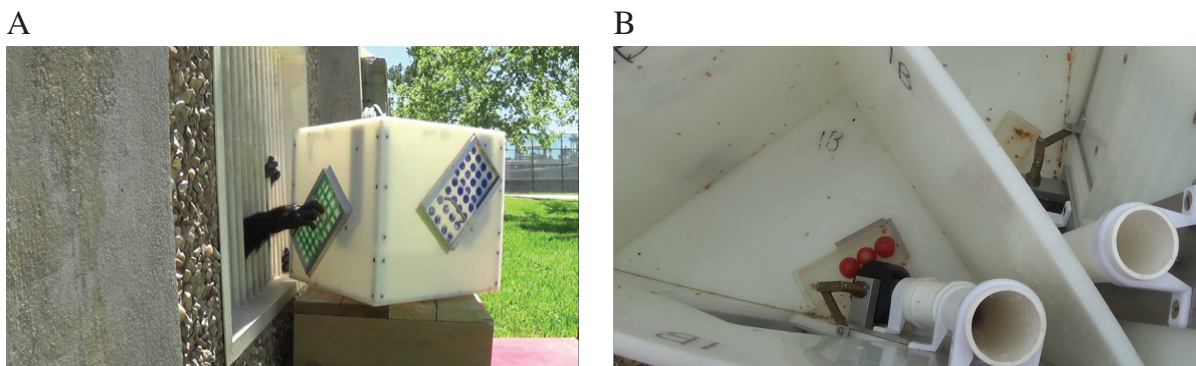

Figure 7.1: *The Lazy-Alpha puzzle-box. The box could freely spin around on a 360 axis and had four ‘doors’, each with differing colour-patterns that when opened released a reward (A). The puzzle-box was self-rebaiting, such that after opening, when no pressure was exerted on a door it would automatically close, and when reopened would dispense another reward (B). Each of the four ‘sides’ corresponding to each door could hold approximately 20 tomato rewards.*

7.2.2.4 Video Demonstrations

For maximum ecological validity, demonstrations using a conspecific would be most desirable.

However, the NCCC had requested that no separations took place during testing which did not permit training individual chimpanzees to act as models where this could be avoided (see Chapter 3.5 for further details). Video demonstrations were thus used to demonstrate two of the four puzzle-box solutions (i.e. door movements) to subjects. Video demonstrations have been shown to successfully seed behaviours in several nonhuman primate species animals species (marmosets; Burkart, Strasser, & Foglia, 2009a; Gunhold, Whiten, & Bugnyar, 2014; gorillas; Howard, Wagner, Woodward, Ross, &

Hopper, 2017; orangutans; Poss & Rochat, 2003; colobus monkeys; Price & Caldwell, 2007, but see Anderson, Kuroshima, & Fujita, 2017). Moreover, chimpanzees from the NCCC have been shown to successfully learn complex tool-use behaviours (Price, Lambeth, Schapiro, & Whiten, 2009) and puzzle-box solutions from video demonstrations (Hopper, Lambeth, & Schapiro, 2012; Vale et al., 2014). Indeed, Hopper and colleagues even found that video demonstrations produced comparable levels of success to conspecific models (Hopper et al., 2012).

Given that this study aimed to investigate individual differences in the propensity to use social and asocial information, a conspecific model may also have biased such tendencies; chimpanzee studies have shown that a model's age, sex, dominance status can influence the likelihood of copying conspecifics (Horner et al., 2010; Kendal et al., 2015; Watson et al., 2017). Thus, a human model, wearing a naturally looking chimpanzee glove (arm length) served to demonstrate solutions. Videos were recorded so that only the 'chimpanzee' arm solving the task was visible. The video demonstrations showed the solution for the Blue Spotted (up-right) door and the Green Chequered (down-left) door (Figure 7.1A), by opening the door, retrieving the cherry tomato reward and holding it in clear view for 3s. To increase subjects' awareness that each door was required to close before re-opening to retrieve the reward, the videos demonstrated three consecutive successful attempts (i.e. three open-reward-close demonstrations). Thus, video demonstrations provided chimpanzees with social information for two sides of the box, while they had no information for the other two doors.

7.2.3 Procedure

Subjects were given 10 hours of video demonstrations (five hours each for the Blue Spotted and Green Chequered sides) prior to puzzle-box exposure. Video demonstrations for each side were presented simultaneously on two identical black laptop computers (Acer Aspire e15 laptops, 17-inch screens)

placed on trolleys in the chimpanzees' indoor enclosures as, at the time of year when testing was conducted, this was where they spent most of their time. The video demonstrations were played for two and a half hours each on the day before and day of testing, on a constant loop. Laptop computers were placed 50cm from the indoor mesh and video demonstration sessions were recorded using a Sony Handycam. For chimpanzees to be classified as observing a video demonstration, it was required that they were within 2.5m of the laptop computer, stationary with their head and gaze directed towards the video displays for at least 5s (which was the approximate time of a single reward extraction in the demonstration). Thus, if a chimpanzee briefly glanced at the video display while continuously moving past, this was not coded as an observation.

Following the final video demonstration session, the two identical puzzle-boxes were simultaneously presented to two barred 'windows' in close proximity to each other, in the chimpanzees' outdoor enclosures (Figure 7.2). Both boxes were presented spinning so as not to make a particular side more salient than others by being the one that subjects initially faced, and to make chimpanzees aware boxes could be spun to access different sides. Testing sessions comprised six 45-minute sessions (4.5 hours in total), where all group members were free to interact with the puzzle-boxes. As soon as rewards from one side were exhausted (i.e., the 20 cherry tomatoes had been retrieved), both puzzle-boxes were pulled from reaching distance and all sides were restocked to maximum capacity. This prevented subjects from changing their actions as a result of reward extinction rather than specifically choosing to do so.

Testing sessions were recorded with Sony Handycams (one per puzzle-box) and two researchers (myself and a NCCC member of staff trained in data collection, LR, one per puzzle-box) narrated live to the camera the identities of subjects interacting with the apparatus, all subjects within 5m of the puzzle-box and all individuals directly observing conspecifics interacting with the puzzle-box. To be deemed

observing a conspecific interacting with a puzzle-box, subjects were required to be within 5m, with their head and gaze directed towards the interactor and/or puzzle-box.



Figure 7.2: Example of the experimental setup. Two identical boxes were simultaneously presented to prevent dominant individuals monopolising apparatuses.

7.2.4 Control conditions

In order to assess whether chimpanzees would be able to solve the Lazy-Alpha puzzle-boxes without video demonstrations, and whether they showed a natural preference for a particular side of the box, control conditions were run. Both puzzle-boxes, baited with the same rewards, were presented to the two control groups of chimpanzees, who received no prior social information (i.e. no video demonstrations). Aside from the lack of video demonstrations, the procedure matched that of the experimental conditions.

7.2.5 Coding

Coding was conducted to assess whether chimpanzees exhibited evidence of social and/or asocial information use from video demonstrations and/or conspecifics, and levels of success. The following coding structure was used for each individual:

Video demonstrations

- The total combined time (s) spent observing both video demonstrations.

Conspecific observations

- The total number of times each individual observed conspecifics interact with the puzzle-boxes (i.e. attempt to solve a side).
- The total number of times each individual observed conspecifics solve the puzzle-boxes, for each side separately, and the overall total.

Puzzle-box interaction

- The number of times each individual solved a video-demonstrated method (Blue Spotted or Green Chequered).
- The number of times each individual solved a non-video-demonstrated method (Black Stripes or Red Stripes).
- The total number of successful attempts overall (i.e. the above combined).
- The total number of sides solved (max. 4).

7.2.6 Statistical analysis

Multiple regression analyses were used to assess whether personality predicted the propensity to observe the video demonstrations and conspecifics, and subsequent performance on the puzzle-boxes using the

coded variables listed above. In all models, social group, sex (male coded as 1, female coded as 0) and mean ratings on each of the six personality traits were entered as predictor variables. Other predictor variables entered for specific models are stated where appropriate. Finally, diagnostic inspections revealed there was no evidence of violations of model assumptions.

For all regression models computed there was no evidence of multicollinearity (all VIFs < 2.0). To control for familywise errors arising from multiple comparisons I used a false discovery rate (FDR) control (Storey, 2002), applied at 10% (see Chapter 3.7), which calculates the expected proportion of false positives (erroneous rejection of null hypotheses) from the discoveries. FDR ‘families’ were selected based on the lines of analyses they investigated, such that one family comprised investigations of use of social information (video demonstrations and conspecifics), another comprised the investigation of puzzle-box behaviours and the experimental-control group comparisons and assessment of cross-task consistencies each also comprised additional families.

7.3 Results

For an overview of all results with model beta values, effect sizes and p-values, see Table 7.2, and for complete details of all regression analyses see Appendix 7.1.

7.3.1 Observations of video demonstrations (social information)

7.3.1.1 Time spent observing video demonstrations⁵

Overall, chimpanzees spent a mean time of 211.33s ($SD = 324.86$) observing the video demonstrations, and 89% ($N = 41$) of subjects observed video demonstrations at least once (as coded, observing for at

⁵ Inspection of the data showed that there were no differences in the time chimpanzees spent observing the Blue Spotted door ($M = 123.27$, $SD = 240.35$) video demonstration vs the Green Chequered door ($M = 78.96$, $SD = 106.11$) video demonstration ($p > .05$), see Appendix 7.1.

least 5s). Ratings of dominance predicted the propensity to observe video demonstrations ($\beta = .427$, $p = .042$), although this was not considered significant under the false discovery rate. Neither social group, sex, nor any other personality trait predicted the time spent watching the video demonstrations (all $p > .05$).

7.3.1.2 Experimental vs control groups

Overall, experimental group chimpanzees displayed a mean of 35.26 ($SD = 66.27$) successful attempts on the Lazy-Alpha and solved a mean of 1.86 ($SD = 1.55$) out of the four possible sides (i.e. doors). Chimpanzees solved the video-demonstrated methods ($M = 21.39$, $SD = 39.84$) significantly more often than they solved the non-demonstrated methods ($M = 14.96$, $SD = 28.81$), Wilcoxon signed rank $Z = 120.50$, $p = .004$.

In comparison, the control groups, who experienced no video demonstrations, displayed a mean of 5.56 ($SD = 5.44$) successful attempts on the Lazy-Alpha and used a mean of 1.68 ($SD = 1.70$) out of four possible methods (i.e. doors). However, these were not significantly different to the experimental groups (both $p > .05$). Further, control group subjects solved the video-demonstrated methods (for the experimental subjects) a mean of 4.13 ($SD = 4.35$) times, which was significantly more times than they solved the non-demonstrated methods ($M = 1.44$, $SD = 1.77$), Wilcoxon signed rank $Z = 1.50$, $p = .013$.

As the control groups showed an unforeseen preference for using the same methods as the experimental chimpanzees (i.e. those that comprised the video demonstrations for the experimental conditions), I next assessed whether there was a bias for any of the four specific doors. Experimental group chimpanzees solved the Blue Spotted door the most frequently ($M = 13.34$, $SD = 23.87$), followed by the Black

Striped door ($M = 9.92$, $SD = 19.08$), then the Green Chequered door ($M = 8.04$, $SD = 19.45$), with the Red Striped door being the least solved method ($M = 5.37$, $SD = 13.44$). These differences were significant, $F = 4.896$, $p = .008$, $\eta p^2 = .093$. Post-hoc analysis showed that the difference between the Blue Spotted Door and the Red Striped door was significant ($p = .016$) in the experimental subjects. By comparison, the control group chimpanzees also solved the Blue Spotted door the most frequently ($M = 2.75$, $SD = 2.91$), followed by the Green Chequered door ($M = 1.38$, $SD = 2.68$), the Black Striped door ($M = 1.13$, $SD = 1.50$), and the Red Striped Door ($M = 0.31$, $SD = 0.60$). As with the experimental groups, these differences were significant, $F = 4.538$, $p = .008$, $\eta p^2 = .232$. Post-hoc analysis showed that the difference between the Blue Spotted Door and the Red Striped door was significant ($p = .026$) in the control subjects. Thus, both the experimental and control groups appeared to have a bias for solving the Blue Spotted door.

7.3.2 Experimental groups: Effects of sex, social group and personality on puzzle-box interactions

7.3.2.1 Number of observations of conspecifics' task interactions⁶

Overall, chimpanzees observed conspecifics interact (attempt to solve a side, regardless of success) with the Lazy-Alpha puzzle-boxes a mean of 47.47 times ($SD = 37.51$). Social group (beta = .307, $p = .041$) significantly predicted the number of times individuals observed conspecifics interacting with the task, suggesting groups differed in their propensity to observe others at the task (i.e. there were significant differences across six testing groups in the rates of conspecific observations across the six groups). Neither sex, time spent observing video demonstrations, nor any personality traits were significant predictors of the number of times individuals observed conspecifics (all $p < .05$).

⁶ Analysis of observations of conspecifics successful attempts (as opposed to overall interaction level) revealed the results remained the same, except that social group was not a significant predictor variable (Appendix 7.1).

7.3.2.2 Total number of puzzle-box successes overall

Analysis of the number of successful attempts revealed that sex was a significant predictor (beta = $-.565$, $p = .008$); females ($M = 63.08$, $SD = 81.66$) exhibited more successful attempts than males ($M = 3.82$, $SD = 7.60$), though this was likely driven by females' greater propensity to interact ($M = 103.12$, $SD = 97.87$) with the Lazy-Alpha than males ($M = 14.39$, $SD = 21.85$, *Mann-Whitney U* = 53.50 , $p > .001$).

The total time spent observing video demonstrations approached significance in predicting the number of successful attempts (beta = $.282$, $p = .067$), suggesting a positive trend for a relationship between time spent watching video demonstrations and puzzle-box success. The number of times individuals observed conspecifics solving the task, social group, and personality traits did not significantly predict the number of successful attempts (all $p > .05$).

7.3.2.3 Number of successes of video-demonstrated methods (Blue Spotted and Green Chequered doors combined)

Analysis of the number of successful attempts on video-demonstrated methods revealed that sex (beta = $-.523$, $p = .014$) was a significant predictor; females ($M = 37.5$, $SD = 49.29$) solved the video-demonstrated sides more times than males ($M = 3.17$, $SD = 6.95$). The total time (s) spent watching the video demonstrations positively predicted success with the corresponding methods (beta = $-.311$, $p = .046$), although this was not considered significant under the false discovery rate, potentially suggesting a relationship between observations of the video demonstrations and successes on their corresponding doors. Neither social group, personality nor the number of times individuals observed conspecifics solve the video-demonstrated methods were significant predictors (all $p > .05$).

7.3.2.4 Number of successes of non-video-demonstrated methods (Red Striped and Black Striped doors combined)

Overall, chimpanzees solved the non-demonstrated methods on the Lazy-Alpha a mean of 14.96 times ($SD = 28.81$). Sex (beta = $-.642$ $p = .003$) was a significant predictor; females ($M = 27.62$, $SD = 35.16$) solved the non-video-demonstrated sides more times than males ($M = 0.65$, $SD = 1.67$). Social group, personality, time spent watching video demonstrations, and the number of times individuals observed conspecifics solve the non-video-demonstrated methods were not significant predictors (all $p > .05$).

Table 7.2: Details of all MMB regression analysis conducted for Experiment 1. **Bold type reflects significance at $p < .05$.** +ve denotes significant positive relationships and -ve denotes significant negative relationships.

	Observations of videos (s) $R^2 = .309$	Observations of conspecifics $R^2 = .330^+$	Total no. of successful attempts $R^2 = .399$	Successes on video demonstrated methods $R^2 = .402$	Successes on non demonstrated methods $R^2 = .406$
Sex					
Beta	-.355	-.135	-.565	-.513	-.642
p-value	.085	.563	.008	.014	.003
Group					
Beta	-.001	.307	.016	-.042	.032
p-value	.996	.041	.911	.763	.882
Agreeableness					
Beta	.036	.227	-.318	.296	-.383
p-value	.867	.333	.135	.163	.071
Dominance					
Beta	+ve	-.404	.008	-.049	.062
p-value	.427	.091	.970	.819	.765
Extraversion					
Beta	-.350	.167	.165	.207	.160
p-value	.100	.460	.430	.321	.442
Methodical					
Beta	.110	-.267	.102	.123	.120
p-value	.507	.460	.539	.451	.467
Openness					
Beta	-.145	.066	.099	.112	.010
p-value	.531	.784	.658	.613	.962
Reactivity					
Beta	.016	.443	.036	-.025	-.074
p-value	.945	.073	.878	.918	.750
Time spent observing video demos (s)					
Beta	N/A	.066	+ve	+ve	-.229
p-value		.692	.282	.311	.139
			.067	.046	

7.4 Discussion

Experiment 1 sought to investigate whether personality predicted chimpanzees' use of social information of solutions to a novel multi-action puzzle-box, in the form of video demonstrations and

conspecifics' behaviours during task interaction. Several findings emerged. First, ratings of personality appeared not to predict the propensity to observe either video demonstrations or conspecifics. Second, as chimpanzees from the control condition performed similarly to those in the experimental condition, there was no evidence that video demonstrations elicited social learning. Third, there were sex effects for interaction and success levels; females exhibited greater success than males on both video-demonstrated and non-video-demonstrated methods, although this was likely a result of females' greater propensity to interact with the apparatus overall than males. Each of these findings will be discussed in detail in the general discussion.

As such, the data in Experiment 1 suggested that video demonstrations did not influence puzzle-box behaviours and that personality does not predict the tendency to observe video demonstrations in these chimpanzees. However, given that both the experimental and control chimpanzees exhibited an unforeseen bias for the Blue Spotted door, it was unclear whether the finding that the experimental chimpanzees solved the video-demonstrated methods more than the non-demonstrated method was due to a potential social learning effect or a natural bias for the Blue Spotted door. Therefore, Experiment 2 sought to further disentangle whether personality predicted learning strategy behaviours by administering a different type of social information, namely live human demonstrations. Moreover, in order to match the child empirical studies from Chapters 4 and 5, social and asocial information were simultaneously pitted against one another.

Based on the same empirical literature as Study 1, the same competing predictions as Experiment 1 were used with one exception. As the personality factor openness in the instrument used here included the facet 'human-orientated' (Table 7.1), it is possible that chimpanzees rated high in openness would show

a greater preference for human demonstrations than those rated low in openness. Thus, the following predictions were made:

1. Dominance, which incorporates boldness, would be related to learning strategy use in one of two ways:
 - a. Dominance would be positively correlated with social information use (Carter et al., 2014; Hopper et al., 2014; Marchetti & Drent, 2000)..
 - b. Dominance would be negatively correlated with social information use (Kurvers et al. 2010).

2. Openness would be related to learning strategy use in one of two ways:
 - a. Openness would be positively correlated with social information use (based on the fact that openness encompasses ‘Human Orientated’ and the social demonstration was from a human).
 - b. Openness would be positively correlated with innovative behaviours (Hopper et al., 2014).

7.5 Experiment 2: Methods

7.5.1 Subjects and personality

The same subjects from the six social groups (49 chimpanzees, $M = 27.71$ years, $SD = 6.28$; 23 males) and two control groups (16 chimpanzees, $M = 23.94$ years, $SD = 5.40$; six males) from Experiment 1, and the corresponding personality ratings, were used in Experiment 2.

7.5.2 Materials

7.5.2.1 Puzzle-box

Two identical rectangular (52cm x 63cm x 23cm) puzzle-boxes (termed Chimbola boxes), that freely rotated on a horizontal axis were used for Experiment 2 (Figure 7.3). A different puzzle-box to Experiment 1 was used so that all chimpanzees had no prior personal or social (i.e. video demonstrations or observations of conspecifics) experience of the task, allowing an assessment of the effect of human demonstrations or asocial information on this specific task. Each puzzle-box had four doors that could be accessed by rotating the box. Each door required a different technique to open; the Green Full-Coloured door required pushing the door away from oneself, Blue Striped required pulling the door towards oneself using a handle, Red Spotted required sliding the door upward-left in a crescent shape and Black Chequered required sliding the door upward-right in a crescent shape.

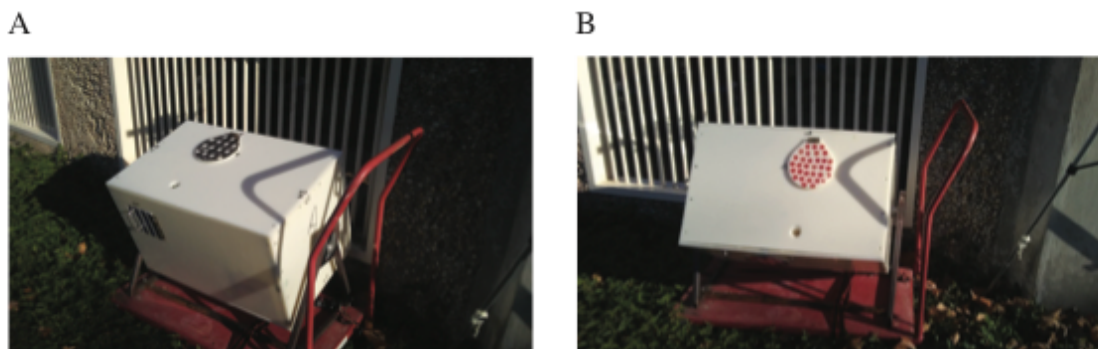

Figure 7.3: Chimbola puzzle-boxes: The boxes could be freely rotated on a 360 degrees horizontal axis to access one of four different doors. Each door required a different technique and had different colour-pattern designs (identical across the two versions of the puzzle-box).

7.5.3 Human demonstrations

In order to directly pit asocial and social information against one another, chimpanzees were simultaneously presented with one box with a social demonstration ('social puzzle box') and one with no demonstration ('asocial puzzle box'⁷) at different barred windows (as in Figure 7.2). For the 'social puzzle-box', the experimenter stood 1m away from the window with the box, and the demonstration consisted of the experimenter (myself) demonstrating how to solve one of the four methods (Red Spots, Figure 7.3), by sliding open the door (up-left crescent manoeuvre), retrieving the reward and presenting it in a way such that it was clearly observable for the subject. To match the video demonstrations, this was repeated a total of three times for each demonstration bout (see Figure 7.4 for an example of a demonstration). Demonstrations occurred when subjects positioned themselves stationary at the barred-window with their head and gaze orientated towards the demonstrator (i.e. walking past did not elicit a demonstration).

To equalise reinforcement effects at each task, and prevent subjects preferentially manipulating the asocial Chimpbola as it alone provided access to food, transparent plexiglass barriers were placed behind each door of the asocial puzzle-box. This ensured that the behaviour of the chimpanzees was unlikely to be driven by motivation for food rather than for any preference for social or asocial learning. Accordingly, with both tasks when a door was opened, the reward was visible to subjects but not obtainable, and remained this way throughout all testing sessions. Anecdotally, 12 chimpanzees attempted to use sticks retrieved from within their outdoor enclosures to manipulate the rewards through the plexiglass, suggesting they were motivated to obtain the rewards.

⁷ While acknowledging that the non-demonstration puzzle-box is not strictly asocial as interaction was done in group settings, this term is used to clearly discriminate it from the social (human demonstration) box.



Figure 7.4: *An example of a human demonstration on the social box.*

7.5.4. Procedure

Testing took place approximately two months after data collection from Experiment 1 ceased. The procedure mirrored Experiment 1 with regards to the location in which testing was conducted. The experimental apparatuses were arranged while chimpanzees were locked in their indoor enclosures, such that when the gate to the outdoor area was opened to allow access, chimpanzees were faced with the social and asocial puzzle-boxes simultaneously. All chimpanzees were free to interact or not with the asocial puzzle-box or to observe live human demonstrations at the social one, and all groups received six 30-minute testing sessions (three hours of exposure in total). Testing sessions were recorded using Sony Handycams, and as with Experiment 1, the identities of individuals interacting with the apparatus, all individuals within 5m of the puzzle-box, and all individuals directly observing conspecifics interacting with the puzzle-box were live-narrated. Again, the asocial box was presented spinning so as not to make a particular side more salient than others and to make chimpanzees aware that the box could be spun to access different sides.

7.5.5. Control measures and groups

Prior to experimental testing, measures of attraction to the human demonstrator and puzzle boxes were obtained to control for individual differences in attraction to humans and puzzle-boxes. For the 'experimenter attraction' data collection, the experimenter to perform human demonstrations during experimental testing (myself) simply stood 1m from the barred windows for five 10-minute sessions, for each group. The 'box attraction' data involved the presentation of a wooden box of a similar shape and size to the Chimpbola (a rectangular box; 46cm x 76.5cm x 35cm) 1m from the barred window for five 10-minute sessions to each group. The mean duration⁸ spent within 2m of the experimenter and box were calculated for all individuals.

In order to assess whether chimpanzees would be able to solve the Chimpbola boxes without demonstrations, and whether they showed a preference for a particular side of the box, control conditions were run. The two Chimpbola boxes were presented to the same two control groups (as Experiment 1) of chimpanzees. Aside from the lack of demonstrations, the procedure matched that of the experimental groups.

7.5.6 Coding

Coding was conducted to assess whether personality predicted chimpanzees' propensity to use social (human demonstrations or observations of conspecifics) or asocial information, and success when solving the Chimpbola. The following coding structure was used:

Human demonstrations

⁸ Latency to approach (s) the experimenter and box was also calculated in addition to mean duration. Inspection of results showed that latency to approach was not a significant predictor in any of the following analyses and thus to reduce the number of variables used, latency to approach was not included in subsequent analysis.

- Whether or not each chimpanzee observed a live human demonstration before interacting with the asocial puzzle-box.
- The total number of times each chimpanzee observed a live human demonstration over the six testing sessions.

Conspecific observations

- The total number of times each individual observed conspecifics interact with the puzzle-boxes, over the six testing sessions.
- The total number of times each individual observed conspecifics solve the puzzle-boxes, for each side separately and the overall total, over the six testing sessions.

Puzzle-box interaction

- The total number of times each individual solved the human-demonstrated method (Red Spotted), over the six testing sessions.
- The total number of times each individual solved a non-demonstrated method (Black Chequered, Blue Striped or Green Full-Coloured), over the six testing sessions.
- The total number of successful attempts over the six testing sessions.
- The total number of sides solved over the six testing sessions (max. 4).

7.5.7 Statistical analysis

A binary logistic regression was conducted to assess whether personality predicted whether chimpanzees initially interacted with the asocial box or observed a human demonstration first (0 = asocial box first, 1 = live human demonstration first). Multiple linear regressions were then conducted to assess chimpanzees' propensity to observe human demonstrations and conspecifics' interactions, and the

puzzle-box behaviours outlined above, over the six testing sessions. In all regression models, sex, social group, ‘experimenter attraction’ data, and ‘box attraction’ data were entered as covariates, while mean ratings on the six personality traits were entered as predictor variables. Other predictor variables entered for specific models are stated where appropriate.

Finally, I assessed whether there was cross-task consistency in the use of social or asocial information as might be expected if related to personality. Specifically, I used Pearson’s correlations to examine whether there were consistencies in observing video demonstrations, human demonstrations and conspecifics across Experiments 1 and 2. As with Experiment 1, diagnostic checks indicated no violations of model assumptions (i.e. multicollinearity, heteroscedasticity etc.).

7.6 Results

Three chimpanzees did not interact with the Chimpbola and did not observe human demonstrations, and thus were omitted from analysis, leaving a total of $N = 46$ subjects (20 males). For an overview of all results with model beta values, effect sizes and p-values, see Table 7.3, and for complete details of all regression analyses see Appendix 7.1.

7.6.1 Social information use

7.6.1.1 Chimpanzees’ first interactions

Altogether, 70% ($N = 32$) of subjects interacted with the asocial puzzle-box before observing a live human demonstration.

The binary logistic regression model (observing social demonstration before Chimpbola interaction vs not observing a demonstration first) was a significant fit (Nagelkerke’s $R^2 = .493$, $p = .010$), and the

model correctly predicted 84.4% of those that did not observe a human demonstration first, and 71.4% of those that did observe a demonstration first. Sex was a significant predictor; males (45%) were more likely to observe a human demonstration before puzzle-box interaction than females (19%), odds ratio = 32.817, $p = .038$. Social group was also a significant predictor (odds ratio = 1.829, $p = .021$), suggesting that groups differed in their propensity to observe the human demonstration or not before puzzle-box interaction. Likewise, the box attraction data was a significant negative predictor (odds ratio = .966, $p = .038$), indicating that individuals who showed a greater box attraction score were less likely to observe a live human demonstration before puzzle-box interaction. Experimenter attraction data, nor any personality trait predicted the propensity to observe the human demonstration before interacting with the Chimpbola (all $p > .05$), but methodical approached significance (odds ratio = 156.064, $p = .068$).

7.6.1.2 Observing human demonstrations over all testing sessions

Overall, chimpanzees observed a human demonstration a mean of 2.89 times ($SD = 2.08$) over the testing sessions, and 93% ($N = 43$) of subjects witnessed a demonstration at least once. Sex approached significance (beta = -.456, $p = .056$), with females ($M = 3.42$, $SD = 2.32$) tending to observe the demonstrations more than males ($M = 2.20$, $SD = 1.51$) over all sessions. Social group, personality, box or experimenter attraction data did not predict the propensity to observe human demonstrations (all $p > .05$).

7.6.1.3 Observing conspecifics over all testing sessions

Overall, chimpanzees observed conspecifics interact with the asocial Chimpbola a mean of 7.78 times ($SD = 9.80$). Social group was a significant predictor of the propensity to observe conspecifics (beta = .485, $p = .002$), suggesting that groups differed in their rates of observing conspecifics. Sex,

experimenter attraction data, box attraction data, and personality traits were not significant predictors (all $p > .05$).

7.6.1.4 Did human demonstrations influence Chimpbola behaviours?

Chimpanzees solved the human-demonstrated side (Red Spotted) a mean of 1.23 times ($SD = 2.17$). This was not significantly different from the number of successful actions on the non-demonstrated sides, ($M = 1.50$, $SD = 2.01$; $t_{45} = -.694$, $p = .492$), suggesting that human demonstrations did not facilitate greater success on the demonstrated method, compared to non-demonstrated methods. In comparison, control chimpanzees solved the Red Spotted door a mean of 0.56 times ($SD = 1.03$), and the non-demonstrated methods a mean of 1.00 times ($SD = 1.03$), and this difference was significant, $t_{15} = 2.41$, $p = .029$, suggesting that control groups were more likely to solve the non-demonstrated sides than the demonstrated side (that the experimental group experienced). In both cases, these were not significantly different to the experimental groups (both $p > .05$). Moreover, the experimental ($M = 1.83$, $SD = 1.41$) and control groups ($M = 1.38$, $SD = 1.36$) did not differ in the number of sides they solved over the six testing sessions ($p > .05$).

As with Experiment 1, there also appeared to be a bias towards the blue door. Experimental group chimpanzees solved the Blue Striped door the most frequently ($M = 2.78$, $SD = 4.37$), followed by the Green Full-Coloured door ($M = 1.50$, $SD = 2.17$), and the Red Spotted door ($M = 1.24$, $SD = 2.01$), with the Black Chequered door being the least solved method ($M = 0.78$, $SD = 1.54$). These differences were significant, $F = 4.992$, $p = .004$, $\eta p^2 = .126$. Post-hoc analysis showed that the difference between the Blue Striped Door and the Black Chequered door was significant ($p = .002$) in the experimental subjects. Similarly, the control group chimpanzees also solved the Blue Striped door the most frequently ($M = 1.38$, $SD = 1.89$), followed by the Green Full-Coloured door ($M = 1.25$, $SD = 1.61$), the Red Spotted

door ($M = 0.56$, $SD = 1.03$), and the Black Chequered door ($M = 0.25$, $SD = 0.58$). As with the experimental groups, this effect was significant, $F = 20.556$, $p < .001$, $\eta p^2 = .264$, however post hoc analyses showed no comparisons were significant.

7.6.2 Overall Chimpbola success

Chimpanzees exhibited a mean of 6.30 ($SD = 8.75$) successful attempts on the Chimpbola over the testing sessions. Sex was a significant predictor; females ($M = 9.38$, $SD = 10.15$) were more successful than males ($M = 2.30$, $SD = 3.97$; beta = $-.609$, $p = .012$), but as with Experiment 1, females ($M = 19.07$, $SD = 19.09$) showed significantly more puzzle-box interactions than males ($M = 6.85$, $SD = 7.85$, $MWU = 138.50$, $p = .007$), which was likely to underpin their greater success rates. Social group, personality ratings, experimenter and box attraction data, and number of observations of live human demonstrations or observations of conspecifics' total number of successes were not significant predictors of overall success on the Chimpbola (all $p > .05$).

Table 7.3: Details of all MMB regression analysis conducted for Experiment 2. Bold type reflects significance at $p < .05$. +ve denotes significant positive relationships and -ve denotes significant negative relationships. ¹ For binary logistic regressions, Nagelkerke's R^2 is reported.

	Percentage of subjects who interacted with the asocial box before observing human demonstration			
	All subjects	Female subjects	Male subjects	
	70%	19%	45%	
	Asocial vs social: first attempt $R^2 = .493^1$	Observations of human demos $R^2 = .296$	Observations of conspecifics $R^2 = .384$	Total successful attempts $R^2 = .418$
Sex	Males = social			
Beta	3.49	-.456	-.260	-.609
p-value	.038	.056	.233	.012
Group				
Beta	.604	.287	.485	.192
p-value	.021	.077	.002	.452
Agreeableness				
Beta	.793	-.169	.191	-.329
p-value	.483	.495	.411	.169
Dominance				
Beta	-1.32	.315	.006	.361
p-value	.147	.175	.977	.109
Extraversion				
Beta	-2.19	.191	.006	.137
p-value	.187	.417	.907	.620
Methodical	+ve			
Beta	5.05	.067	-.284	.313
p-value	.068	.715	.103	.085
Openness				
Beta	.271	.236	.277	-.315
p-value	.845	.270	.355	.210
Reactivity				
Beta	1.31	.157	.017	-.346
p-value	.229	.543	.944	.163
Experimenter attraction				
Beta	-.019	-.073	-.283	.049
p-value	.172	.680	.095	.779
Box attraction	-ve			
Beta	-.035	-.456	.051	.163
p-value	.038	.540	.747	.312

7.6.3 Cross-task consistency: Experiments 1 and 2

I next assessed whether the propensity to acquire the different types of social information were consistent across the two experiments. For analysis details, see Table 7.4.

The time subjects spent observing video demonstrations (Experiment 1) was significantly positively correlated with the number of times subjects observed a live human demonstration (Experiment 2), $r_s = .405, p = .004$, suggesting that individuals who spent more time watching video demonstrations also tended to watch live human demonstrations. There was also a strong positive correlation between the number of times individuals observed conspecifics interacting with the Lazy-Alpha (Experiment 1) and the Chimpbola (Experiment 2), $r_s = .559, p > .001$, potentially suggesting individual consistency in the propensity to observe conspecifics interacting with the two separate tasks. Finally, within Experiment 2, the number of times individuals observed human demonstrations was significantly positively correlated with the number of times individuals observed conspecifics on Chimpbola, $r_s = .329, p = .021$. Thus, individuals who observed human demonstrations were also likely to observe conspecifics on the Chimpbola.

Table 7.4: Assessment of cross-task consistency (Pearson's correlations) in learning strategy behaviours. Bold type reflects significance at $p < .05$.

	1.	2.	3.	4.
1. Time spent observing video demonstrations (Experiment 1)	-	$r_s = .033$	$r_s = .405^{**}$	$r_s = .222$
2. No. of times observed conspecifics interact with Lazy Alpha (Experiment 1)		-	$r_s = .158$	$r_s = .559^{***}$
3. No. of times observed human demonstration (Experiment 2)			-	$r_s = .329^*$
4. No. of times observed conspecifics interact with Chimpbola (Experiment 2)				-

$p < .05^*$; $p < .01^{**}$; $p < .001^{***}$

7.7 Discussion

Experiment 2 aimed to further elucidate underlying individual differences in social and asocial information use, by simultaneously providing chimpanzees with an asocial four-action puzzle-box and live human demonstrations for the same task. Results revealed that the majority of chimpanzees interacted with the asocial box before observing human demonstrations - although over the testing sessions almost all subjects witnessed a human demonstration. Personality did not predict the propensity to acquire social information (observing either through human demonstrations or conspecifics) or not, contrasting previous literature reporting an association between personality and nonhuman animal learning strategies. Live human demonstrations appeared to not influence puzzle-box behaviours; subjects were equally as likely to solve non-demonstrated methods as demonstrated methods and there were no differences in performance between experimental and control conditions. However, the apparent lack of social learning may have been at least in part explained by the fact that both the control and experimental subjects again displayed a greater natural preference for a non-demonstrated side (Blue Striped). Despite this, there was some potential evidence of consistencies in learning strategy behaviours across experiments; chimpanzees who observed conspecifics during task interaction in Experiment 1 were also likely to do so in Experiment 2, and similarly, chimpanzees who spent more time observing video demonstrations in Experiment 1 also showed a propensity to observe human demonstrations in Experiment 2. Finally, although females were less likely than males to initially observe a human demonstration before task interaction, over the entire testing sessions females tended to observe human demonstrations more than males. These findings will be discussed in detail in the next section.

7.8 General Discussion

The predominant aim of this study was to assess whether personality correlated with chimpanzee's use of social or asocial information when solving novel puzzle-boxes. Across two experiments, chimpanzees were exposed to two experimentally induced types of social information – video of a 'chimpanzee' arm solving a puzzle-box and live human demonstrations – as well as being able to observe conspecifics during task interaction. While there was evidence of individual consistencies in the use of social information across the two studies, personality largely appeared to not influence the learning strategies chimpanzees adopted.

7.8.1 Use of social or asocial information

The literature indicates that chimpanzees principally rely on asocial information and are broadly reticent to use social information, especially if it is directly pitted against asocial information (Vale, Flynn, et al., 2017; van Leeuwen, Call, et al., 2014). The data here corroborate these claims; in Experiment 2, the majority of chimpanzees first interacted with the asocial box before observing a human demonstrator, and human demonstrations did not influence puzzle-box behaviours and in both studies, experimental groups did not perform differently to control groups in terms of preferentially solving demonstrated methods (despite the vast majority of subjects observing video and human demonstrations), and similarly, observations of conspecifics' puzzle-box behaviours appeared not to influence subjects puzzle-box behaviours in both experiments. These findings are in direct contrast to studies of children showing that the majority tend to elect for social information over solving novel apparatus asocially (Flynn et al., 2016, Chapter 4) and that children remain strikingly faithful to demonstrated methods on puzzle-boxes (Carr et al., 2015; Nielsen, Mushin, Tomaselli, & Whiten; Whiten, Allan, et al., 2016). Chimpanzees' greater reliance on individually acquired information compared to humans' is suggested to contribute to the 'cultural gap' between the two species, as children are better equipped to socially

acquire and maintain the skills, technology and customs of their social group (van Leeuwen, Call, et al., 2014).

In contrast to some previous studies (Gunhold et al., 2014; Hopper et al., 2012; Howard, Wagner, Woodward, Ross, Hopper, et al., 2017; Poss & Rochat, 2003), but in line with others (see Anderson et al. 2017), Experiment 1 revealed no evidence of learning from video demonstrations. It is possible that the video demonstrations used here were not salient enough or that the use of a ‘chimpanzee arm’ was in itself novel and distracting. Future work could aim to examine the conditions (including task and model type) in which video demonstrations for chimpanzees are most effective and when they appear to be least effective.

An unexpected finding was that in both experiments, experimental and control subjects demonstrated a bias for the Blue Doors (Spotted and Striped in Experiments 1 and 2, respectively). It is unclear why this bias manifested, but whether the findings that in Experiment 2 chimpanzees in the experimental condition were equally as likely to solve the non-demonstrated methods (which included the Blue Striped door) was a result of learning strategies thus remains unclear due to this bias (and indeed potentially, so does the finding that chimpanzees were more likely to solve video-demonstrated method in Experiment 1, which included the Blue Spotted door). There may be several possible explanations for this finding. One possible reason is that the chimpanzees were influenced by odour cues from other individuals’ previous interactions. However, puzzle-boxes were all cleaned with disinfectant after each testing session, which likely reduced/eliminated any such cues across testing sessions. While in Experiment 1 the doors were all structurally similar (the difference being the direction the door is maneuvered in), the Blue Striped door in Experiment 2 was the only to have an ‘overt’ (protruding) handle – the other three doors required pushing or sliding without a handle. As such, another potential explanation for the bias in Experiment 2 is that the more salient handle meant chimpanzees were drawn

to this over other doors without handles. Additionally, there is some evidence that chimpanzees and gorillas show a preference – as measured by level of attention – for green and blue colours over red (Wells, McDonald, & Ringland, 2008), results directly corroborated in terms of solving behaviours in Experiment 1 in both conditions. This may suggest that colour bias may have also been a contributing factor to this particular finding.

7.8.2 The role of personality

Previous work with a range of nonhuman animal species has reported that personality – with particular focus on boldness and similar traits - predicts learning strategy use (Carter et al., 2014; Kurvers, Prins, et al., 2010 and Chapter 2.6.3 and 2.7.2). Additionally, in the NCCC chimpanzees, openness (as assessed by the same scale used here) was correlated with duration of asocial puzzle-box interaction (Hopper et al., 2014). Here, personality showed no relationship with the learning strategies the chimpanzees adopted. This may suggest that in these chimpanzees, personality (as assessed using this instrument) is not an important contributing factor to social or asocial information use when solving novel problems, or indeed that the task used here is not sensitive enough. These results contrast findings from those of other nonhuman animals and recent work in humans suggesting specific traits predict learning strategies (Rawlings et al., 2017, Chapter 4).

There are, however, differences in the experimental setup of the present experiments to the previous studies which may also contribute to the differing findings. For example, one pertinent difference involves the measures used to assess personality in the studies linking boldness-shyness or neophobia-neophilia with learning strategy use. These studies measured these traits through assays of behavioural observations, often by presenting novel objects to individuals and measuring their responses (Aplin et al., 2014; Carter et al., 2014; Kurvers, Prins, et al., 2010; Marchetti & Drent, 2000). The present study

used a six-factor model based on human ratings, and although boldness is a facet of the factor dominance as measured here, dominance also included several other facets that may not predict learning strategy use which may explain why it did not correlate with other types of social information use. With regards to the findings by Hopper et al. (2014), the present study did not include measurements of duration of puzzle-box interaction, and as such the data here precludes a direct comparison. It is also important to note that in the study by Hopper and colleagues, chimpanzees were tested individually rather than in groups, and the differences between individual and social testing may have important influences on individual behaviours (for discussions of individual and group testing, see Chapter 8.5.1.1).

It may also be that other measures of individual differences are more influential than the personality data collected here. For instance, rearing history has been highlighted as a potential factor in problem solving behaviours (Haslam, 2013; Leavens et al., 2010; Tomasello & Call, 2004; Whiten, 2000), although a recent meta-analysis of the NCCC chimpanzees found no effects of rearing history on the NCCC chimpanzees' propensity to engage in social learning (Watson et al., 2018). Chapter 5 revealed that individual differences in measures of social network centrality predicted children's learning strategy behaviours, while a growing body of nonhuman animal work has linked network centrality to the propensity to engage in social information use and/or innovation (Aplin, Farine, Morand-Ferron, & Sheldon, 2012; Carter, Tico, & Cowlshaw, 2016; Claidière, Messer, Hoppitt, & Whiten, 2013, Chapter 5.1). While beyond the scope of this thesis, measures of social network data have been collated for the NCCC chimpanzees and will be analysed in relation to the learning strategy behaviours across Experiments 1 and 2 in the future.

7.8.3 *Cross-task consistency*

While personality appeared not to predict the learning strategies chimpanzees adopted in this study, there was evidence of cross-task consistency in the propensity to acquire social and asocial information. The cumulative time subjects spent observing video demonstrations in Experiment 1 was significantly correlated with the number of times subjects observed human demonstrations in Experiment 2. Similarly, there was also a significant positive correlation between observing conspecifics across experiments. This seems to indicate that chimpanzees were consistent in their propensity to acquire social information across domains (and conversely, not to acquire social information). Several recent studies have shown that humans consistently differ in their use of social and asocial information across different tasks (Molleman et al., 2014; Toelch et al., 2013; Toyokawa et al., 2017), and that such differences may have important implications for cultural evolution (Efferson, Lalive, Richerson, McElreath, & Lubell, 2008; Toelch et al., 2013), yet we know little about whether this extends to chimpanzees. Although these data are correlational, the findings here perhaps indicate that chimpanzees also show cross-task consistency in the use of social and asocial information. Context-independent consistencies in chimpanzees' propensity to use social or asocial information would thus demonstrate similarities with these recent findings with humans. Future work could build upon these findings to establish the extent to which chimpanzees (and other nonhuman primates) display cross-task consistencies in social and asocial information use over a variety of different task types, and indeed whether there is a task-context interaction. For instance, further data on subjects' propensity to observe conspecifics in non-puzzle-box contexts would allow an assessment of whether such findings reflect genuine task related social information use, or other factors (for example, subordinate individuals monitoring dominant conspecifics to avoid aggression, or a general desire to be close to other individuals). Moreover, assessment of other measures of individual differences (i.e. social network

measures, as alluded to above) may also be fruitful in determining factors underlying individual consistencies in the use of social information across tasks.

7.8.4 Sex differences

Interestingly, while males were more likely than females to witness a demonstration *before* interacting with the Chimpbola, over all of the testing sessions combined in Experiment 2, females tended to observe demonstrations more than males. These findings both contrast and support the literature on sex differences in social information use. The greater overall use of social information of females converges with evidence from studies with chimpanzees and humans. For instance, Lonsdorf, Eberly and Pusey (2004) found that young female chimpanzees in Gombe more closely observed, and matched, their mothers' termite fishing techniques than young males, and Vale and colleagues found that female chimpanzees were more likely to exchange tokens based on social information than males (Vale, Flynn, et al., 2017). Indeed, and more pertinently, the recent meta-analysis of social learning studies conducted at the NCCC found that the only predictor of social information use was sex, with females showing a greater proclivity to acquire social information than males (Watson et al., 2018). This indicates that in these chimpanzees, females are more inclined to obtain social information across a variety of social learning tasks than males. Recent studies of human adults also indicate that females display a greater tendency to use social information than males (Brand et al., 2018; Cross et al., 2017), and Chapter 4 revealed that female children were more likely to overtly select social over asocial information than male children. As such, the findings that females here show an overall greater use of social information potentially adds to the growing body of studies of documenting sex-differences in social information use.

However, that male chimpanzees (controlling for box and experimenter attraction) were more likely than females to observe a human demonstration before interacting with the asocial puzzle-box was not expected. It is unclear why this finding manifested; in the empirical child study of Chapter 4, females were significantly more likely to explicitly elect for social demonstrations than males, but there were no sex-differences in children's copying propensity over subsequent attempts. This finding is particularly unexpected given that males are the dominant sex in chimpanzees. Dominant individuals are prone to monopolising experimental apparatus (Cronin et al., 2017), and thus ostensibly, dominant individuals (i.e. males) should initially gain access to the asocial box as this was available to interact with. Although the experimenter (myself) did not provision food during the data collection period (or for during Experiment 1), it is possible that in these chimpanzees, a human (i.e. the demonstrator) may be more attractive than a puzzle-box given that the caregivers provide food to chimpanzees during feeding times, in which they are not required to solve tasks to obtain. Thus, while the findings here may reflect species differences in sex-differences in learning strategy behaviours when using a novel approach, by simultaneously pitting social and asocial apparatus against one another, further work is needed to establish whether this extends to non-human demonstrators.

It is important to acknowledge some limitations of the present studies. A key question is whether the type of experimentally induced social information (video and live human demonstrations) was ecologically valid enough to elicit social acquisition of the specific techniques for the Lazy-Alpha and Chimpbola. While human demonstrators have been successfully used to impart social information to chimpanzees, including puzzle-box solutions (Horner & Whiten, 2004; Whiten, Custance, Gomez, Teixidor, & Bard, 1996), there have also been cases where chimpanzees have only acquired some aspects, or have failed to socially learn human demonstrated behaviours, potentially questioning their validity (Buttelmann, Carpenter, Call, & Tomasello, 2013; Nagell, Olguin, & Tomasello, 1993). Similar

arguments have been levelled at the validity of video demonstrations for nonhuman primates (Anderson et al., 2017). While the present study did not permit using live conspecific models, it is possible that results may have differed using this approach (Hopper, Lambeth, Schapiro, & Whiten, 2015; Kendal et al., 2015; Vale et al., 2016).

Second, testing was conducted in group settings. Although this is not a limitation, as group settings allow an investigation of learning strategies use in dynamic, naturalistic contexts, this approach does present difficulties with data interpretation. Individual testing allows researchers to better isolate the effects of cognitive mechanisms and individual differences on performance by removing non-experimental influences such as social dynamics (see Chapter 8.5.1.1 for a discussion of group and individual testing). Indeed, as alluded to, previous work using the same personality assessment with chimpanzees from the same facility has reported a relationship between personality and asocial performance on puzzle-box tasks (Hopper et al., 2014). As such, it is important for future work to further examine the relationship between personality and social information use, and to provide points of comparison for the present experiments, by using conspecific models and testing in individual settings.

7.9 Conclusions and implications

Across two studies, chimpanzees were exposed to different types of social information (video demonstrations, human demonstrations and conspecifics during group testing) and novel, four-action puzzle-boxes, performance on which was investigated for correlations with ratings on a six-factor personality instrument. The findings suggest that while there was some potential evidence of social learning from video demonstrations, consistent with several prior studies, chimpanzees largely appeared to rely on individually obtained information. Moreover, the personality traits assessed here largely did not predict the learning strategies these chimpanzees adopted.

By exposing chimpanzees to different types of social information, the experimental design allowed the first documentation of consistencies in subjects' propensity to use each type of social information. The results correspond to recent reports of individual consistencies of social information use in humans (Molleman et al., 2014; Toyokawa et al., 2017). Further, by simultaneously presenting 'asocial' and social apparatus to chimpanzees, it was found that overall the majority of chimpanzees interacted with the asocial apparatus rather than the social one. Moreover, although males were more likely than females to initially observe a demonstration before interaction, females were more likely than males to observe human demonstrations over subsequent testing sessions. Some of these results are in direct contrast to those found in this thesis with children (Chapter 4). Such findings are an important step to unravelling what may differentiate chimpanzees from humans, the most cultural species on the planet. In each species, we learn which individuals are important for the innovation of behavioural variants, and which are important for the social transmission of these innovations.

Chapter 8: General Discussion

The aim of this thesis was to examine individual differences in the use of social and asocial information in children and chimpanzees. Using an experimental approach, both species were presented with novel, multi-action puzzle-boxes, and measures of personality (children and chimpanzees) and social network positions (children) were collated and correlated with learning strategy use. This approach enabled the work within this thesis to address several questions, including; 1) whether there are individual differences in learning strategy use, 2), if so, whether factors such as personality (children and chimpanzees) and/or social network properties (children) correlated with these individual differences and, 3) whether there were similarities and differences in the learning strategy behaviours, and individual differences underpinning them, between species.

This chapter will discuss the findings of the thesis, including unifying and disparate themes, how they fit within the overall field of cultural evolution and their broader implications. I finish with a discussion of the strengths and weaknesses of the methodology used throughout this thesis, before highlighting how these can be used as stepping stones for potential future directions.

8.1 Preferences for social or asocial information

Children are formidable social learners. A wealth of research has shown that children have an extraordinary capacity to socially acquire, maintain and transmit (often complex) skills and behaviours even from early childhood (Carr et al., 2015; Nielsen et al.; Price et al., 2017; L. A. Wood et al., 2013a), and show an overt preference for social over asocial information (Flynn et al., 2016). In contrast, although also capable of socially acquiring and transmitting complex behaviours (Horner et al., 2006), chimpanzees appear to rely less on social information than do children, particularly when it directly conflicts with individual information (Vale, Flynn, et al., 2017; van Leeuwen, Call, et al., 2014). As van Leeuwen et al. (2014) noted, the apparent greater value that humans place on social information than chimpanzees may underpin the ‘cultural gap’ between the two species.

The results from Chapters 4 and 7 directly corroborate these findings. When offered the choice of social demonstrations or no demonstrations before interacting with a novel apparatus (Chapter 4), 61% of seven- to 11-year old children elected for demonstrations, and children were largely faithful to the observed behaviours over their subsequent interaction attempts. By contrast, when simultaneously faced with apparatus accompanied by social information or not (Chapter 7, Experiment 2), the majority of chimpanzees (70%) first interacted with the puzzle-box affording asocial learning only, before observing human demonstrations. Although there was some tentative evidence that the chimpanzees acquired solutions for one type of puzzle-box (the Lazy-Alpha) from video demonstrations using a ‘conspecific arm’ (Chapter 7, Experiment 1), social information obtained from human demonstrations (for a different puzzle-box; the Chimpbola, Experiment 2) and from observations of conspecifics (Chapter 7, Experiments 1 and 2) appeared not to influence chimpanzees’ behaviours.

Children's bias for social information is likely to yield some disadvantages, but several benefits. Most young children perform poorly on experimentally induced (asocial) innovation challenges (Beck et al., 2011; Frick et al., 2017; Nielsen, 2013), and it has been suggested that children's pre-potent preference to acquire social information may contribute to their difficulties with innovation (Flynn et al., 2016). Chapter 4 provided novel additional support for this claim. The minority of children who elected to bypass social demonstrations were more likely than those who elected for social demonstrations to manufacture a tool on the Hook Task and scored higher on measures of divergent thinking. This represents possibly the first evidence that explicit learning strategy choice is related to innovative and creative performance. Plausibly, this willingness to engage in asocial problem solving means these children are more frequently exposed to situations that require generating novel thoughts and behaviours.

On the other hand, a preference for social information may be an adaptive mechanism for obtaining the extensive range of instrumental and culturally-specific skills and behaviours children face (Legare & Nielsen, 2015). Successful acquisition of such behaviours is essential to within-group homogeneity - a standout feature of culture (Richerson & Boyd, 2005). If and when novel innovations arise, humans are well-placed to socially acquire and preserve these cultural variants, which in turn can be built upon/modified to continue the cycle. Chimpanzee's greater reliance on individually-acquired information is likely a critical factor in their comparatively limited cultural repertoire. By being comparatively reticent to acquire and use social information, novel innovations are less likely to be taken up and transmitted within chimpanzee populations (Call, Carpenter, & Tomasello, 2005; Carpenter & Call, 2009; Davis et al., 2016; Vale, Davis, et al., 2017; van Leeuwen, Call, et al., 2014).

8.2 Individual differences in learning strategy use

As recently as 2017, understanding individual variation in social learning and innovation was highlighted as a major unanswered question for the field of cultural evolution (Mesoudi, 2017). Despite, as detailed in Chapter 2, a recent shift in focus from aiming to understand *why* or *when* individuals use social or asocial information, to aiming to understand *who* uses social or asocial information, there is still much work to be done - particularly from a comparative perspective (Mesoudi et al., 2016; Nielsen & Haun, 2016; Rawlings et al., 2017).

The recent shift in focus does mean, however, that we are beginning to accumulate a burgeoning list of characteristics that appear to shape the use of social and asocial information across human and nonhuman animals. These include (but are not exclusive to) age, sex, developmental stress, cultural background, IQ and physiological status (Mesoudi, Chang, Dall, & Thornton, 2016; Chapter 2). Pertinent to this thesis, individual differences in personality and social network positions have also recently been highlighted as understudied, yet potentially fruitful avenues for research in this area (Rawlings et al., 2017). As such, the primary aim of this thesis was to expand upon these developments and assess whether these, and other individual differences (such as age and sex) are related to the learning strategies children and chimpanzees adopt. By using contemporary developments in methods to assess personality and social network analysis, this thesis allowed for systematic, direct (personality) and indirect (social network data) cross-species comparisons.

8.2.1 Personality

The literature review in Chapter 2 highlighted that a small, but growing collection of studies have both directly and indirectly associated certain personality traits with humans' propensity to engage in social learning and innovation. In particular, studies involving infants had found that extraversion is positively

correlated with social information use, while literature predominantly from the field of industry has consistently linked openness to experience with innovative performance. In Chapter 4, I aimed to build upon these findings and extend the limited number of personality traits studied, by assessing whether the Big Five personality traits predicted both children's overt choice of learning strategy and their subsequent task interaction.

Results indicated that children rated by parents as high in conscientiousness were more likely to elect to solve a novel puzzle-box without demonstrations, while children rated as high in agreeableness were more likely to elect for demonstrations before tackling the puzzle-box. Further, within the children who elected for demonstrations, those rated as high in openness to experience exhibited a greater propensity to deviate from the observed methods. Thus, the data revealed both consistencies and inconsistencies with the existing literature.

Openness to experience encompasses being inventive, curious, exploratory and broad-minded, and thus it is inherently linked with the construct of innovation (novel behaviours that are produced so as to successfully solve a novel problem or an existing problem in a novel manner; Carr, Kendal, & Flynn, 2016). Interestingly, although children rated as high in openness to experience did exhibit innovative behaviour, by being more likely to deviate from observed behaviours, this was *innovation-by-modification*, rather than by-invention. Thus creative, inventive and curious children are perhaps not those who elect to attempt to solve novel problems through asocial endeavours, but instead are those who can generate novel behaviour based on observing and modifying others' actions. Multiple studies have shown that children find deviating from adult demonstrations a difficult task (Carr et al., 2015; Johnston et al., 2017; L. A. Wood et al., 2015), and that functional fixedness (the proclivity to become fixed on a pre-learned function for an object) is likely a major hurdle in this respect (German &

Defeyter, 2000). The data here suggest that inventive and broad-minded children are able to see beyond observed behaviours and are willing to try alternative methods to solve novel problems, rather than becoming canalised on specific (witnessed) functions. Innovation-by-modification is essential for our species' ability to cumulatively develop our cultural repertoire, and although, our understanding of socially-mediated innovation is in its infancy (Carr et al., 2016; Hopper, 2016), and future work is required to establish whether these relationships extends to adults, these findings are an important first step in identifying which rare individuals are more likely to engage in attempting to modify the instrumental skills they observe.

Although theoretically, agreeableness is likely to correlate with social information use, no previous study had formally investigated this relationship. Agreeableness denotes being trustful, kind, affiliative, cooperative and prosocial – all characteristics that intuitively map on to social information use, especially under the forced-choice paradigm. Socially acquiring information is crucial to both the maintenance of population-specific behaviours, and the uptake of novel, innovated variants. The data from Chapter 4 suggests that prosocial, affiliative and trusting individuals are those that actively seek social information when it is offered. However, that agreeableness showed no relationship with copying fidelity over the subsequent 10 attempts at extracting rewards from the task indicates that other characteristics may be required for the successful social transmission of behaviours. It might be that individuals who simultaneously score high in agreeableness (actively seek social information) and low in openness to experience (less likely to deviate from social information) are those that are important for maintaining within-group cultural uniformity.

That conscientiousness predicted the propensity to elect to solve a novel puzzle-box asocially was not expected. Conscientiousness (incorporating being industrious, orderly and goal-orientated) is generally

negatively linked with creativity (Chamorro-Premuzic, 2006), and thus on face value would not be expected to correlate with the propensity to elect to ‘go it alone’. However, conscientiousness is also related to characteristics - such as an exaggerated self-efficacy and a desire to be in control of a given situation (Donnellan & Robins, 2010; Lee & Klein, 2002; Lepine et al., 2000) - that fit with the propensity to elect to tackle novel tasks asocially, rather than to defer to another individual and allow them to interact first. Indeed, given that conscientiousness was not related to innovative behaviour on the puzzle-box across children’s subsequent attempts (i.e. deviation from witnessed methods or use of multiple novel techniques) may indicate that the role of conscientiousness is specific to the forced-choice (i.e. electing for social demonstrations or not) element of the design. Nonetheless, most children were not willing to tackle the novel task asocially, and by nature doing so requires children to individually invent potential solutions to the tasks – which may or may not be successful/improvements on other individuals’ existing methods. Thus, conscientiousness, coupled with openness to experience may be important traits in the production of novel cultural variants.

Extraversion has been linked with social information use, and attraction to social stimuli, in several studies of children and adults (Rawlings et al., 2017; Chapter 2). Individuals scoring high in extraversion are gregarious, active, dominant and bold; as with agreeableness, the inter-personal characteristics of extraversion intuitively lend themselves to social information use. Yet, extraversion showed no relationship with children’s propensity to elect for demonstrations or copying fidelity. Although these findings may suggest that the link between extraversion and learning strategy behaviours is complex, they may also reflect the differences in the tasks and the measures of personality used across these studies. Previous studies with children have used a toy playing game (Hilbrink et al., 2013) and measured the ability to judge others as reliable sources of information tasks (Canfield et al., 2015), while adult work has used computer based decision-making tasks (Cook et al., 2014). Similarly, the measure

of personality used in Chapter 4 differs from each of these studies; both Hilbrink et al. (2013) and Canfield et al. (2015) assessed young children (three years and under) using the Infant Behavioural Questionnaire, whereas Cook et al. (2014) used self-ratings of social and aggressive dominance. While not detracting from the finding that extraversion was not related to social information use in this study, these discrepancies mean drawing concrete cross-study conclusions is difficult.

Chapter 7 took a comparative approach by assessing whether personality predicted chimpanzees' learning strategy behaviours. Although no study had specifically investigated whether personality ratings predicted chimpanzee learning strategy use, several studies from the nonhuman animal literature had found the boldness-shyness and neophobia-neophilia axes to be important predictors of learning strategy use (Brosnan & Hopper, 2014; Chapters 2 and 7). As detailed in Chapter 6, the field of nonhuman animal personality has dramatically accelerated in recent years, and an increasing collection of studies have used species comparable measures of personality, reporting that great apes display personality traits comparable to the Big Five in humans. A principle aim of Chapter 7 was to use one such instrument to assess whether personality influenced chimpanzee learning strategy use in ways comparable to both the human (and nonhuman) literature and to the findings of Chapter 4.

Across two experiments, chimpanzees were exposed to various types of social information, including video demonstrations of 'conspecific arms', live human demonstrations and observations of conspecifics during task interaction. In line with prior evidence linking boldness to social information use in nonhuman animals (Carter, Marshall, Heinsohn, & Cowlshaw, 2014; Marchetti & Drent, 2000; Trompf & Brown, 2014, Chapter 2.6 and 2.7), there was no evidence that caregiver ratings of dominance, or any other personality trait, was correlated with chimpanzees' propensity to observe video demonstrations, live human demonstrations or conspecifics. Chapters 2 and 4 highlighted a range of ways in which

children and chimpanzees differ in the learning strategy behaviours they display, and while acknowledging it is unclear how influential the task differences between the two experiments were, the findings of Chapter 7 potentially indicate that species-differences in the role that personality plays (or does not play) in learning strategy use can be added to this list. That is, personality appears to be an important factor in children's learning strategy behaviour in terms of propensity to elect for, and fidelity to, adult demonstrations, and also potentially influences chimpanzees' proclivity to acquire certain forms of social information (video demonstrations), but not others (live human demonstrations, observations of conspecifics).

However, the exploratory nature of this study, and methodological disparities from others mean further work is needed to verify these findings. Almost all other studies investigating whether nonhuman animal personality predicts social or asocial information use have collected their personality data through behavioural assays (e.g. Carter et al., 2014; Kurvers et al., 2010; Marchetti & Drent, 2000; Trompf & Brown, 2014) rather than through human ratings, and the explicit definitions of relevant traits (e.g. boldness) often differ across measurement approaches (Carter et al., 2012; Freeman et al., 2011). Further, owing to logistical and practical matters, the experimental design of Chapter 7 (chimpanzees) differed from that of Chapter 4 (children) (which will be addressed in section 8.5). Thus, some caution must be used when drawing cross-chapter conclusions.

8.2.2 Social network positions

Given the fundamental importance of the social environment for the opportunities to engage in both social learning and innovation (Carr et al., 2016; Coussi-Korbel & Fragaszy, 1995; Turner & Flynn, 2016), there is a striking lack of research – particularly from a developmental perspective - investigating whether individual differences in personal social environments shape the learning strategies adopted. As

with the study of children's personality, Chapter 5 was driven by work largely from industry and nonhuman animal studies, which had highlighted two separate ways in which network centrality may predict the use of social and asocial information. On the one hand, several studies had revealed that network centrality (and popularity) was positively linked with social information use - ostensibly as a result of sheer exposure to others' behaviour (Christakis & Fowler, 2008; Claidière et al., 2013; Flynn & Whiten, 2012). Alternatively, other studies had found that holding central network positions facilitates innovation, suggested to result from central individual's access to informational diversity through interaction with multiple others (Baer, 2010; Baer et al., 2015). By using a subset of participants and the same task data from Chapter 4, the aim of Chapter 5 was to investigate whether individual differences in social network positions correlate with individual differences in learning strategy use in children.

The results demonstrated that children with a high degree centrality score (i.e. identified as having many friends) displayed more innovative behaviour on the puzzle-box, both in terms of propensity to deviate from observed demonstrations and by being less likely to repeat previously used actions (in those who elected for no demonstrations). These results thus support the theoretical work from the business literature proposing that central individuals, through multiple social interactions, can synthesise the diverse lines of information they experience to promote novel behaviour and ideas (Baer, 2010; Baer et al., 2015; Fleming & Waguespack, 2007; Kratzer & Lettl, 2008).

The fact that degree centrality was related to innovative behaviour in children who elected for demonstrations and in children who elected for no demonstrations provides robust evidence that being embedded in one's social network promotes different forms of innovation and across contexts. Moreover, these findings also support the growing pool of work moving away from the traditional notion of innovation as purely asocial and in direct opposition to social learning. As Muthukrishna and

Henrich state, innovation is the product of our social interactions rather than the result of rare independent inventors:

“...We instead argue that innovations, large or small, do not require heroic geniuses any more than your thoughts hinge on a particular neuron. Rather, just as thoughts are an emergent property of neurons firing in our neural networks, innovations arise as an emergent consequence of our species' psychology applied within our societies and social networks.” (Muthukrishna & Henrich, 2016, pg 2).

Thus, by documenting that children identified as having multiple social connections are more innovative than those with fewer connections, the results of Chapter 5 support the growing understanding that our complex social structures play a crucial role in the innovation process, even at the individual level. Further, this data also indicates that the field of cultural evolution could fruitfully adopt the theoretical work from industry as a model to continue to investigate how an individual's position in their network predicts the relative use of social and asocial information.

8.2.3 Age and sex effects

This thesis examined seven- to 11-year old children; an age range older than that typically tested in cultural evolution studies. A key aim of this approach was to build upon two recent studies with younger children to extend our knowledge of the developmental trajectory of social and asocial information use. Flynn, Turner, and Giraldeau (2016) used the same learning strategy forced choice paradigm with three- and five-year olds, finding that, irrespective of task-difficulty, 75% of participants elected for social demonstrations. Relatedly, Carr, Kendal, and Flynn (2015) found that, across four- to nine-year old children, older participants were more likely than younger children to deviate from adult demonstrations on the same puzzle-box used within the empirical work here in Chapters 4 and 5.

The result within this thesis directly converge with the above studies, and thus with the notion that with age, children's reliance on social information reduces. The proportion of children who elected for social demonstrations in Chapter 4 (61%) is smaller than that from Flynn et al. (2016) with younger children, and there was a linear negative trend across age-groups; 69% of children in the youngest age group (school Year 3) elected for social demonstrations, compared to 54% of children in the oldest age group (school Year 6). Similarly, matching the findings from Carr et al. (2015), older children were more likely to deviate from demonstrations than younger children. These findings therefore extend the growing body of work suggesting that both socially- and asocially- mediated innovation is a late developing skill.

There is currently no unifying theory as to why we see age-related decreases in social information use. It is possible that as children age and their cognitive capacities (such as executive functions, planning, causal reasoning and inhibition) develop, they become better equipped to engage in innovation. Children's success rates on innovation challenges show a linear age-related trend (Beck et al., 2011; Chappell, Cutting, Apperly, & Beck, 2013) which ostensibly corresponds with cognitive development. Indeed, adult neuroimaging studies have highlighted the importance of working memory for tool-use skills (Johnson-Frey, Newman-Norlund, & Grafton, 2005). However, in a recent study of five- to seven-year old children, measures of executive function did not predict success on the Hook Task - although a proxy measure of general intelligence did (Beck et al., 2016). This suggests that the relationship between innovative capacity and cognitive development is not straightforward. The demands of tool innovation are likely to require various cognitive processes, and further work is required to isolate the role that cognitive development plays on children's innovative capacities.

An unforeseen theme throughout this thesis was that of sex differences in the propensity to use social and asocial information. In Chapter 4 (with the full cohort of child participants), while the majority of children elected for social demonstrations, this was driven by females; males were almost equally as likely to elect for demonstrations or no demonstrations, yet 71% of the female participants elected for social demonstrations. Although sex differences in children's use of social and asocial information had previously not been documented (analysis by sex was not reported in the learning strategy choice paradigm in Flynn et al. [2016] precluding a comparison), two recent adult studies have found that females exhibit a greater proclivity for social information use than males (Brand et al., 2018; Cross et al., 2017). In these studies, task-confidence (Cross et al., 2017) and risk-aversion (Brand et al., 2018) were highlighted as mediating factors in females' greater use of social information. As tackling novel tasks asocially, rather than socially, is a riskier strategy (confirmed by the lower success rates of children who did not witness demonstrations) and presumably requires confidence in one's own problem-solving abilities to 'go it alone', it is plausible that either, or both of these factors contributed to female children's greater proclivity to select social demonstrations than males.

Chapter 7 revealed an interesting pattern of sex differences in chimpanzees' learning strategy behaviour. In Experiment 2, males were more likely than females to observe a human demonstration before interacting with a puzzle-box, but over the course of the rest of the testing sessions, females were more likely to observe human demonstrations. Conversely, there were no sex differences in the propensity to observe both video demonstrations combined (Experiment 1) or conspecifics (Experiments 1 and 2). Thus, the sex differences in social information use were limited to observations of human demonstrations.

While very few studies have explicitly examined sex differences in chimpanzee learning strategy behaviours, those that have report that females exhibit a greater propensity to acquire social information (from conspecifics) than males in both natural (Lonsdorf et al., 2004) and experimental contexts (Vale, Flynn, et al., 2017). Moreover, in their review of the innovation literature, Reader and Laland (2001) found that males displayed higher rates of innovation than females, potentially denoting a greater propensity to use asocial information. Most pertinently, however, a recent meta-analysis of all social learning studies conducted with the NCCC chimpanzees found sex to be the only significant factor in social information use, with females more likely than males to engage in social learning (Watson et al., 2018). As such, that females tended to observe demonstrations over the study period converges with each of these findings. Conversely, that males were initially more likely to observe a human demonstration is the first documentation, to my knowledge, of male chimpanzees showing greater social information use than females, in any circumstance. This potentially reflects the novel experimental design, in which both an asocial and social puzzle-box were simultaneously pitted against one another. Given that male chimpanzees are dominant over females and thus are more likely to access the resource of their preference, it may be that in such instances, males are more inclined to initially observe demonstrations, but that over time, females' greater motivation for social information means they show greater rates of observations of demonstrations.

However, caution must be exercised when interpreting these findings, as sex-differences were limited to human demonstrations, rather than video demonstrations or observations of conspecifics. As the NCCC chimpanzees are routinely fed by human caregivers (without having to solve tasks) this may reflect that humans are more attractive to (male) chimpanzees than puzzle-boxes. Moreover, the human demonstrations themselves did not appear to elicit social learning in either males or females, suggesting that the sex-difference in propensity to observe human demonstrations (either initially or over all testing

sessions) did not manifest in the implementation of this social information. Accordingly, although these results potentially add novel findings to, and support of, the existing literature, further work is needed to validate these data.

These findings also provide a point of comparison with the empirical work with children (Chapter 4). For example, that over the entire testing sessions female chimpanzees were more likely than males to observe demonstrations fits with the results that female children were more likely to elect for social demonstrations, potentially providing further support to the existing literature of both humans and chimpanzees which seems to point to greater social information use in females. Conversely, that males were more likely to observe the human demonstration before interacting with the puzzle-box than females (who were more likely to first interact with the asocial puzzle-box) directly contrasts with the sex-differences in children's explicit choice of learning strategy. Accordingly, while again differences in experimental setup between the two empirical chapters means care should be exerted when extracting conclusions, the findings here potentially reflect cross-species continuity and variation in sex-specific learning strategy use.

In summary, the findings from Chapters 4, 5 and 7 shed new light on how cultures may emerge and establish. Innovation and social learning are essential for cultural diversification; innovations introduce new cultural variants into populations and social learning underpins their dissemination (and thus establishment) throughout populations. Across a series of experiments, results indicated that individual differences in age, sex and measures of personality and social network properties map onto individual differences in children's propensity to solve problems through innovation and social learning, thus providing key data on who might be those that generate new behaviours and who might be those that facilitate their diffusion throughout groups. Equally, that ratings of broadly similar traits did not predict

chimpanzees' learning strategy behaviours indicates species-variation in the factors that underpin learning strategy choices.

8.3 Cross-task performance and the importance of experimental design

An important aspect of this thesis has been the use of a variety of, often novel, experimental manipulations and tasks across children and chimpanzees. By taking this approach in this thesis I have provided several important and unique insights regarding learning strategy performance in different contexts.

The forced choice paradigm of Chapters 4 and 5 shed new light on the understudied field of children's explicit learning strategy preferences. The vast majority of studies investigating children's learning strategy behaviour have bestowed social or asocial information upon participants as part of the experimental setup. For instance, studies of social learning (including 'overimitation') typically involve exposing children to social information and documenting their fidelity to demonstrated behaviours (Flynn & Whiten, 2010; Keupp, Behne, Zachow, Kasbohm, & Rakoczy, 2015; Nielsen et al.; Vale, Flynn, et al., 2017; Whiten, Allan, et al., 2016; L. A. Wood et al., 2013a), while studies of children's innovative capacities generally measure innovation by examining success on asocial problem solving tasks (Beck et al., 2011, 2016; Hanus et al., 2011; Neldner et al., 2017; Nielsen et al., 2014). As described in Chapter 2, these studies have been crucial in highlighting children's contrasting social learning and innovative abilities. However, before Flynn et al. (2016), no study, to my knowledge, had investigated whether children overtly chose social over asocial information, and we had no knowledge of how such choices correspond with performance on the types of social learning and innovation tasks traditionally used in the literature.

The experimental design of the child empirical studies had three main implications. First, it served to verify the findings of Flynn et al. (2016) that most children elect for social demonstrations over no demonstrations. Second, as alluded to, it revealed that in this age group, there were sex- and age-related differences in the propensity to elect for demonstrations. Third, it also revealed that children who elected to bypass social information were more likely to manufacture a hook tool with the pipe cleaner on the Hook Task, and produced both more, and more original, uses for a paperclip (Alternate Uses), than did children who elected for social demonstrations. This latter finding represents the first evidence that children's *explicit* choice to solve novel problems asocially correlates with performance on measures of asocial innovation and creativity. As such, administering multiple tasks to participants affords the potential to detect patterns of consistencies in cross-task performances.

Similarly, Chapter 7 employed several novel experimental manipulations. In spite of the differences in design to Chapter 4, by presenting asocial and social puzzle-box simultaneously to chimpanzees (Experiment 2), results revealed an almost exact opposite finding to that of the children; whereas 61% of children elected for a social demonstration before interacting with the puzzle-box, 70% of the chimpanzees interacted with the asocial box before observing a social demonstration. Using this experimental design, these findings add a new dimension corroborating the theoretical and empirical literature signifying that chimpanzees (and other nonhuman animals), in contrast to humans, primarily rely on individual information, and use social information as a 'back up' strategy when individual information is costly to acquire or outdated (Davis et al., 2016; Hirata, Morimura, & Houki, 2009; Kendal et al., 2009; Templeton & Giraldeau, 1996; van Leeuwen, Call, et al., 2014).

Furthermore, over two experiments, chimpanzees were presented with two different types of multi-action puzzle-boxes and were exposed to three different forms of social information. Assessment of

behaviours across both tasks revealed correlations in the use of social information; observations of video demonstrations was correlated with observation of human demonstrations, as was the propensity to observe conspecifics across the two studies. As discussed in Chapter 7.8, without further data regarding individual-propensity to observe conspecifics in non-foraging contexts it is unclear whether such findings reflects a genuine proclivity to collect social information (as opposed to being a byproduct of monitoring aggressive/dominant others, for example). Nonetheless, this was, to my knowledge, the first report of consistencies in chimpanzees' tendency to acquire different types of social information across experimental tasks. Therefore, as with Chapter 4, exposing the same subjects to multiple tasks/types of social information revealed not-before-seen patterns of learning strategy behaviour.

Chapter 6 also explored the validity of using previously-collected personality data when assessing chimpanzee performance on cognitive tasks. The logistical difficulties of collating up-to-date personality data means that many studies lean on ratings collected several years prior to experimental testing (e.g., Altschul, Wallace, Sonnweber, Tomonaga, & Weiss, 2017; Brosnan et al., 2015; Herrelko, Vick, & Buchanan-Smith, 2012; Hopper et al., 2014; Latzman, Hecht, Freeman, Schapiro, & Hopkins, 2015). The lack of longitudinal studies investigating chimpanzee personality stability means that we have very little knowledge of how representative such previously-collected personality ratings are. The results of Chapter 6 revealed that over the 10-year period, ratings of three of the six factors significantly differed, and males and females displayed diverging patterns of trajectory for two factors (openness and agreeableness). Further, only dominance exhibited strong rank-order stability; the other five traits exhibited moderate-low stability, indicating that individuals were variable in their ordinal rank-position, and thus that there was variation in how stable individuals were in their ranking position relative to others over the study period, for five of the six personality factors.

These findings may have broad implications for researchers investigating how personality associates with performance in a variety of domains. For instance, several studies have reported the importance of openness in chimpanzee study participation and performance on cognitive tasks, including puzzle-box and touch screen task paradigms (Altschul et al., 2017; Herrelko et al., 2012; Hopper et al., 2014). In Chapter 6, while across all subjects ratings of openness did not differ over the study period, there was a sex-effect; males were rated as significantly lower in openness while females increased by a similar (but not significant) margin over the 10 years. Depending on the time between personality data collection and empirical testing, subjects' personality ratings of certain (and often relevant) traits may thus be reduced in relevance.

However, these implications potentially extend beyond the field of cognitive performance. Individual variation in chimpanzee personality traits has been linked with individual variation in responses to inequity aversion (Brosnan et al., 2015), social organisation (Massen & Koski, 2014) and even neuroanatomical structure (Latzman et al., 2015); all of these experiments relied on personality ratings collected for previous studies, or which had been collected in years prior. Thus, a key conclusion from this study was that, where possible, researchers collect (or use) up-to-date personality data when attempting to assess its relationship with performance in other domains.

8.4 Personality and social networks

While not central to the aims of this thesis, the data from this thesis also allows an examination of the relationship between personality and social network positions, and to be fully comprehensive I next outline whether the findings of Chapters 4 and 5 in unison convergence with the existing human personality-social network literature.

Ostensibly, personality and social networks are intertwined. Gregarious and social individuals presumably hold central network positions, whereas reserved or less prosocial individuals hold peripheral positions. However, surprisingly few studies have investigated this relationship, and none, to my knowledge have done so with children. In adults' advice networks, extraversion relates positively to centrality, implying that extraversion facilitates giving and receiving advice in social groups (Klein, Saltz, & Mayer, 2004). While this corresponds with literature documenting a link between extraversion and learning strategies (see Chapters 2.6.2 and 4.1), in this thesis, extraversion did not predict children's use of social or asocial information. Similarly, in the same study (Klein et al., 2004), openness to experience was negatively related to centrality in friendship networks, suggesting that adults high in openness to experience hold peripheral network positions. This is also incongruent with the findings that openness to experience (Chapter 4) and network centrality (Chapter 5) were both positively related to innovative behaviours. However, while the data from this thesis do not easily fit with the findings of Klein and colleagues, given that there are so few studies examining the relationship between the Big Five personality traits and social network positions, formal conclusions should be withheld until further studies - particularly with children - have been conducted. Indeed, studies showing a relationship between children's creativity and popularity (Lau & Li, 1996; Li et al., 2013), and findings that adults high in openness to experience are more active social media users (Ross et al., 2009) hint at a relationship between creativity and network centrality.

The integration of personality and social network analysis promises to be a valuable technique in helping us map how cultural traditions arise. Innovations may be driven by creative (high openness to experience) or confident (high conscientiousness) personality types who have many associations (high degree centrality) within a network. In turn, such innovations may be acquired by more cooperative and trusting (agreeableness) and less creative (low openness to experience) individuals, facilitating their

spread throughout the group. Understanding who is more likely to be those that innovate new behaviour and who is more likely to be those underpinning the social diffusion of these behaviour may help understand how humans' technological evolution differs so dramatically from other species. This is, of course, speculative, but highlights the potential of this area for cultural evolution research.

8.5 Limitations of the thesis studies

The studies have a number of limitations, which could be used as platforms for future work. These include but are not exhausted by: the specific populations of participants and subjects tested, the contexts in which data collection occurred and the methods used to collect data. I will now address some of the key limitations in detail, before moving on to discuss how they facilitate future research.

8.5.1 Differences in experimental setup between child and chimpanzee studies

A primary aim of this thesis was a comparative analysis. As such, for the most direct comparisons, it would have been optimal to mirror the contexts in which testing took place for children and chimpanzees. Practical and logistical issues meant that the experimental conditions and manipulations differed between the empirical Chapters of 4 (and 5) and 7. Throughout this and previous chapters I have highlighted that these differences preclude, to some extent, the types of conclusions that would be possible based on matching experimental conditions. I now examine these differences and their implications in more detail.

8.5.1.1 Individual versus social testing

Whereas testing of children was conducted individually, owing to NCCC requirements chimpanzees were tested in their social groups. Both of these approaches offer strengths and weakness; individual testing permits researchers to isolate the conditions, manipulations or mechanisms that shape

behavioural outcomes (Tucker-Drob, 2011). Equally, social group testing provides a naturalistic context in which individuals engage in social and/or asocial information use, and thus allows an assessment of the dynamic nature of learning strategy behaviour (Flynn & Whiten, 2010). However, direct comparisons between the two contexts can be difficult, owing to the myriad of potential variables that differ across the two contexts (for a discussion of the differences between individual and group testing in children's social learning studies, see Flynn & Whiten, 2010). For instance, when conducting individual-testing, researchers can select demonstrators based on specific characteristics, yet this is not typically possible in group testing. Given that both children and chimpanzees display several biases influencing from whom they are more or less likely to learn (Kendal et al., 2015; Price et al., 2017; Wood et al., 2013b), there are likely to be differences in learning behaviour as a result of differences from whom individuals are learning from across contexts. Similarly, individual testing is often an unnatural context; children may defer to adult experimenter's behaviours (or behaviours they feel are expected) while isolating chimpanzees for testing may induce temporary stress, and thus testing among peers and conspecifics is likely to elicit more natural behaviours. This point is particularly pertinent given studies in adults that suggest a personality-context interaction. For example, extraversion increases individuals' performance on creativity tasks under test conditions (i.e., when arousal increases; (Chamorro-Premuzic & Reichenbacher, 2008)), and adults who score high in neuroticism experience increased anxiety in social contexts when compared with those who score low in neuroticism (Norton et al., 1997). As such, the differences between individual and social group testing may have contributed to the differences in findings between the empirical studies of children and chimpanzees.

8.5.1.2 Types of social information and methods of presentation

Children who elected for social information, when faced with a novel task, were exposed to live adult demonstrations of puzzle-box solutions. As discussed in Chapter 3.5.2, NCCC requirements meant that

employing trained conspecific demonstrators was not possible throughout Chapter 7, and thus subjects were exposed to video demonstrations by ‘conspecific hands’ before task interaction (Experiment 1) and live human demonstrations (Experiment 2). While children are generally prolific social learners, multiple studies have established that adult models stimulate higher-fidelity copying than similar aged peers (L. A. Wood et al., 2013b). In addition, although video and human demonstrations have been successfully applied in chimpanzee social learning studies (Hopper et al., 2012; Horner & Whiten, 2004; Price et al., 2009; Whiten et al., 1996) it is plausible that conspecific models may have produced different results (see Chapter 7.8 for a discussion on the literature using human, video and conspecific demonstrations). Thus, children may have experienced contexts that facilitate higher-fidelity copying (and social information use) compared to the chimpanzees.

Likewise, while verbally offering children the choice of social demonstrations or to tackle the apparatus asocially yielded novel and valuable insights into how they overtly value social and asocial information, clearly this approach is difficult with nonhuman animals (it is potentially achievable using extensive prior training, but this was beyond the time-scale of the thesis). As such, it was impossible to exactly match the verbal forced choice experimental design with chimpanzees. Simultaneously presenting an asocial and social puzzle-box to chimpanzees goes some way to match the child experimental design and, indeed, yielded interesting findings, which can be tentatively compared to those derived from Chapter 4. However, whereas, in the context in which it was framed, the children were likely to infer that the experimenter would intentionally impart task-relevant information, it is unclear whether the same applies to chimpanzees – particularly regarding their initial ‘choice’ to approach the asocial or social puzzle-box. Each of these, and other, factors therefore mean that the findings from this thesis can likely only be used as initial points of comparison, rather than being definitive.

8.5.2 *WEIRD children and BIZARRE chimpanzees*

Developmental psychology has recently begun to acknowledge the need to broaden our studies to include children in populations beyond so-called WEIRD (Western, Educated, Industrialised, Rich and Democratic) societies (Henrich et al., 2010; Nielsen & Haun, 2016; Nielsen et al., 2017). The vast majority of developmental psychology, including cultural evolution research, has been conducted in Western populations. Without detracting from the wealth of invaluable knowledge this research has provided, cross-cultural research is essential for determining the degree to which cultural background influences learning strategy use. Studies have begun to document cross-cultural similarities and differences across adults and children in important cultural processes such as the relative use of social information (Mesoudi et al., 2014), copying fidelity (Clegg & Legare, 2016; Corriveau et al., 2017), the propensity to ‘overimitate’ (Berl & Hewlett, 2015; Chudek et al., 2016; Frick et al., 2017; Nielsen & Tomaselli, 2010) and innovation capacity (Frick et al., 2017; Neldner et al., 2017; Nielsen et al., 2014). Thus, without assessment of whether children in a variety of cultures predominantly elect for social information, and whether the same individual differences (personality, social network positions, age and sex) shape their learning strategy behaviour, interpretations from this thesis should be limited to the specific population of UK children tested within this thesis.

Equally, we are limited in the conclusions drawn from studies of captive chimpanzees. In an analogous argument to those outlined above with WEIRD children, Leavens and colleagues have suggested chimpanzees raised in ‘BIZARRE’ contexts (Barren, Institutional, Zoo, And other Rare Rearing Environments) are a poor representation of the species as a whole, and that within- and cross-species comparisons are reduced in strength by studying subjects from such environments (Leavens et al., 2010, 2017). There is evidence to suggest that nonhuman animals from captive populations perform differently to wild populations on a range of cognitive measures, including problem-solving (termed ‘captivity

bias'; for a review see Haslam, 2013). The increased free time and energy, interaction with humans, and the greater potential to observe conspecifics using experimentally induced apparatus and have been highlighted as contributing factors to this captivity bias (Haslam, 2013; Leavens et al., 2010). Similarly, the relative isolation of captive rearing and physical environments (i.e. interaction with tasks through enclosure barred-windows) have also been stressed as factors limiting comparisons with both wild primate populations and lab-based human data (Leavens et al., 2017). Although field experiments have been an important progression in recent years for understanding the learning strategies of wild nonhuman primates (Gruber et al., 2009; Gunhold et al., 2014; van de Waal, Bshary, & Whiten, 2014; van de Waal et al., 2013), conducting controlled experiments in field settings remains a relatively difficult and costly pursuit. Accordingly, we must be cautious when drawing conclusions from nonhuman populations housed in captive environments.

In summary, while this thesis did not permit data collection of cross-cultural child populations, or of populations of wild chimpanzees, it is important to acknowledge that the findings are limited to some extent to the study populations within this thesis (i.e. Western children and captive chimpanzees).

Significantly, however, the studies within this thesis are amenable for study beyond the samples studied here, which will be discussed in section 8.6.4.

8.6 Future directions

The limitations outlined above set the stage for future research. Throughout this chapter, and the thesis in general, I have hinted at several prospective directions for future work. I will now discuss some of the more pertinent and potentially fruitful avenues for prospective further research in more detail.

8.6.1 Untangling potential causal or mediating factors, the and direction of, the relationships found

The exploratory nature of Chapters 4, 5, 6 and 7 means future studies are critical to establish the robustness of each of these findings. In principle, the majority of the findings obtained from this thesis require further examination to both validate them and establish the potential causal factors and directionality of significant relationships.

The findings that conscientiousness and agreeableness were related to children's explicit choice of social or asocial information opens the door for investigation of the direction of these relationships. For instance, agreeableness is related to the propensity to trust others (Freitag & Bauer, 2015; Gerris et al., 2010; Mooradian et al., 2006; Soto & John, 2012), and to the motivation to establish positive relationships with others (Barrick et al., 2002). As discussed in Chapter 4, given that both trust and motivation for affiliation have also been highlighted as factors in children's propensity to use social information (Harris, 2007; Over & Carpenter, 2013), either, both or none of these factors may mediate the relationship between agreeableness and electing for collection of social information. Relatedly, whether highly conscientious children elect to solve problems asocially as a result of the relationship between high conscientiousness and the desire for control (Lepine et al., 2000), or with perspectives of high self-efficacy (Lee & Klein, 2002), or indeed another explanation, requires further examination. Experimental manipulations of (for example) affiliative context and children's relative level of control over the apparatus or situation, as well as supplementing empirical data with questions about their trust of demonstrators and perspectives of self-efficacy would be important initial steps for unraveling the directions of these findings.

Similarly, although the business literature proposes that network centrality is positively correlated with innovative behaviour as a result of information diversity, there is also some evidence that creativity

facilitates popularity among peers (Lau et al., 2004; Li et al., 2013; Newcomb et al., 1993). It is possible that both are contributing factors; creative individuals may be popular (and thus central) among peers, which in turn exposes them to informational diversity. However, this remains speculative until further work is conducted. Experimentally manipulating the informational diversity children receive prior to puzzle-box exposure is one potential fruitful technique. Additionally, asking children to explain why specific individuals are popular, through open or closed questions, may also help ascertain whether they highlight creativity and innovative characteristics as important features for class popularity. Finally, as alluded to in Chapter 7.8, social network data have been collated for the NCCC chimpanzees and will be analysed in relation to the learning strategy behaviour across Experiments 1 and 2 in the future. Such analyses will afford comparisons with the child data of Chapter 5 and with previous nonhuman animal work linking network centrality to the propensity to engage in social information use and/or innovation (Aplin, Farine, Morand-Ferron, & Sheldon, 2012; Carter, Tico, & Cowlshaw, 2016; Claidière, Messer, Hoppitt, & Whiten, 2013, Chapter 5.1).

Prior to the empirical study of Chapter 6, no study had examined the long-term stability of chimpanzee personality by longitudinally comparing ratings using the same personality instrument. The findings of consistencies and discrepancies with previous cross-sectional studies highlight the importance of collecting both types of data, and the need for further verification. Continuing to document the long-term stability of chimpanzee personality across different populations (both captive and wild), and over multiple time-points would allow assessment of whether chimpanzees show population-specific patterns of personality development (which in turn would open up the question of the role of the specific environment on personality development e.g., Sapolsky & Share, 2004) and provide a more fine-grained temporal view of patterns of personality development.

Chapter 7 revealed that personality appeared not to play a role in chimpanzees' propensity to use (or not) a variety of types of social information (although there was tentative evidence that dominance was associated with the propensity to observe video demonstrations). Whether the finding that personality largely did not predict such behaviour simply represents species differences (to humans and other nonhuman animals) in the underlying factors contributing to learning strategy use, or the specificities of the methodology of Chapter 7 requires further examination. For instance, as highlighted in the chapters 7.8 and 8.5, it is plausible that using conspecific models rather than humans, or individual rather than group testing may impact the results. Moreover, the development of the field of animal personality now means there are a range of instruments to measure personality in nonhuman primates, including ones that directly correspond with the Big Five as assessed in humans (i.e. the Hominoid Personality Questionnaire; King & Figueredo, 1997). Whether such instruments yield results more or less comparable with the human literature remains to be seen.

8.6.2 Tracking the developmental change of children's learning strategy choices into adolescence

In conjunction with the study by Flynn et al. (2016), the data in this thesis indicate a linear negative developmental trend, from young- to late-childhood in the propensity to explicitly elect for social demonstrations over solving novel tasks asocially. An obvious next step is to extend this study into adolescence (for whom we have very little knowledge of learning strategy behaviour in general). Adolescence brings a protracted period of cognitive and emotional maturation, which appears to have emerged late in humans' evolutionary history (Bainbridge, 2010). It would thus be valuable to examine whether this increasing trend of the propensity to select for asocial information (and indeed innovative capacity) extends into adolescence, such that we see lower levels of social information use in that age group than we do in the studies conducted in this thesis and by Flynn et al. (2016) and Carr et al. (2015).

In turn, this would theoretically allow interpretations of whether the willingness to tackle problems asocially corresponds with cognitive development across early lifespan.

8.6.3 Developing the use of multi-action puzzle-boxes

A major experimental aim of this thesis was to move beyond the traditionally used ‘two-action’ puzzle-boxes used in human and nonhuman animal cultural evolution studies. Two-action designs have been fundamental in developing our knowledge of how cultural traditions are maintained and diffused throughout populations of a wide range of taxa including birds, monkeys, apes and humans (Aplin et al., 2015; Auersperg et al., 2011; Benson-Amram, Heinen, Gessner, Weldele, & Holekamp, 2014; Flynn & Whiten, 2012; Hopper et al., 2007; Price & Caldwell, 2007; Whiten & Flynn, 2010). Without the ingenious design and implementation of these studies, we would have much less knowledge of the processes underpinning cultural behaviour in such processes. Furthermore, the ability to implement the same two-action apparatus designs (indeed often the same apparatus) have also afforded invaluable direct, cross-species comparisons (Horner et al., 2006; Tennie, Call, & Tomasello, 2006; Whiten et al., 1996).

Nonetheless, as discussed in Chapter 3.3, multi-method apparatuses offer a potentially more powerful and ecologically valid technique for assessing learning strategy behaviour (Bijvoet-van den Berg & Hoicka, 2014; Whiten, Allan, et al., 2016). In our ever-increasing technologically advanced world, children likely face a range of problems more complex than those with binary two-action solutions. Multi-action puzzle-boxes offering a more diverse set of potential task-related behaviour, have been successfully administered in a growing body of studies with children and nonhuman primates, addressing questions such as cumulative culture (Dean et al., 2012; McGuigan et al., 2017), individual differences in creativity (Bijvoet-van den Berg & Hoicka, 2014) and age-differences in copying fidelity

(Carr et al., 2015). The development and implementation of these and other multi-method apparatuses will continue to be an important progression within the field of cultural evolution.

8.6.4 Moving beyond WEIRD AND BIZARRE populations

As considered in section 8.5.1, the conclusions drawn from this thesis are limited to some extent to the populations studied, and knowledge of cross-population continuity and variation in learning strategy behaviours (in both humans and wild nonhuman animals) remains a fundamental gap in the cultural evolution literature (Nielsen & Haun, 2016; Nielsen et al., 2017). However, the development of dedicated field sites across the world, coupled with advances in experimental methodology (including field experiments) are opening pathways to exciting opportunities to bring lab-based studies to a diverse range of populations, both in terms of cross-cultural human research, and of wild populations of nonhuman primates.

As previously alluded to, studies have begun to document cross-cultural similarities and differences across adults and children in important cultural processes (Berl & Hewlett, 2015; Corriveau et al., 2017; Frick et al., 2017; Mesoudi et al., 2014; Neldner et al., 2017) and the development of field experiments means we are increasingly seeing (comparatively) controlled studies including with puzzle-box designs used to assess cultural learning in wild nonhuman primate populations (Gruber et al., 2009; Gunhold et al., 2014; van de Waal et al., 2014).

Pertinent to this thesis, measures of the Big Five personality traits are beginning to be translated and implemented into a range of languages and cultures, including forager-horticulturalist societies (Gurven, von Rueden, Massenkoff, Kaplan, & Lero Vie, 2013), while long-term field stations mean researchers now have years of experience with populations of wild chimpanzees, and thus are well placed to act as raters of subject's personality (Weiss et al., 2017). Furthermore, advances in techniques for the collation

and analysis of social network data mean researchers can systematically map population-level social dynamics, and can track the social diffusion of behaviours and skills across groups of humans in natural environments (Cattuto et al., 2010; Christakis & Fowler, 2008; Fournet et al., 2014; Fowler & Christakis, 2008) and wild populations of a range of nonhuman animal species (Allen et al., 2013; Hobaiter et al., 2014; Jones, Aplin, Devost, & Morand-Ferron, 2017). These developments mean the field of cultural evolution is well placed to amend its over reliance on WERID and BIZARRE populations.

8.7 Concluding remarks

In conclusion, the evidence presented within this thesis reveals that children and chimpanzees show species differences and similarities in their propensity to engage in social learning and innovation, and the individual factors underpinning individual variation in the proclivity to adopt both types of learning strategy. The results from here thus add to our growing understanding of how within species, individuals consistently differ in the propensity to adopt social or asocial information when faced with novel problems, and the factors underpinning these individual differences. Furthermore, by employing several, often novel, experimental designs, the empirical work within this thesis provided new insights in to cross-task patterns in learning strategy use in children and chimpanzees. Social learning and innovation are crucial for cultural evolution, and this thesis emphasises the need to continue to increase our focus on disentangling the relative importance of individual differences for learning strategy use across species.

References

- Aitken-Harris, J. (2004). Measured intelligence, achievement, openness to experience, and creativity. *Personality and Individual Differences, 36*(4), 913–929. [https://doi.org/10.1016/S0191-8869\(03\)00161-2](https://doi.org/10.1016/S0191-8869(03)00161-2)
- Aktamov, S., & Zhao, Y. (2014). Impact of network centrality positions on innovation performance of the firm: Evidence from China automobile industry. *Business Management and Strategy, 5*(1), 164. <https://doi.org/10.5296/bms.v5i1.5183>
- Allen, J., Weinrich, M., Hoppitt, W., & Rendell, L. (2013). Network-based diffusion analysis reveals cultural transmission of lobtailing feeding in humpback whales. *Science, 340*(6131), 485–488. <https://doi.org/10.1126/science.1231976>
- Altschul, D. M., Wallace, E. K., Sonnweber, R., Tomonaga, M., & Weiss, A. (2017). Chimpanzee intellect: personality, performance and motivation with touchscreen tasks. *Royal Society Open Science, 4*(5), 170169. <https://doi.org/10.1098/rsos.170169>
- Anderson, J. R., Kuroshima, H., & Fujita, K. (2017). Observational learning in capuchin monkeys: a video deficit effect. *Quarterly Journal of Experimental Psychology, 70*(7), 1254–1262. <https://doi.org/10.1080/17470218.2016.1178312>
- Anestis, S. F., Bribiescas, R. G., & Hasselschwert, D. L. (2006). Age, rank, and personality effects on the cortisol sedation stress response in young chimpanzees. *Physiology & Behavior, 89*(2), 287–294. <https://doi.org/10.1016/j.physbeh.2006.06.010>
- Aplin, L. M., Farine, D. R., Mann, R. P., & Sheldon, B. C. (2014). Individual-level personality influences social foraging and collective behaviour in wild birds. *Proceedings. Biological Sciences / The Royal Society, 281*(1789), 20141016. <https://doi.org/10.1098/rspb.2014.1016>
- Aplin, L. M., Farine, D. R., Morand-Ferron, J., Cockburn, A., Thornton, A., & Sheldon, B. C. (2015). Experimentally induced innovations lead to persistent culture via conformity in wild birds. *Nature, 518*(7540). <https://doi.org/10.1038/nature13998>
- Aplin, L. M., Farine, D. R., Morand-Ferron, J., & Sheldon, B. C. (2012). Social networks predict patch discovery in a wild population of songbirds. *Proceedings. Biological Sciences / The Royal Society, 279*(1745), 4199–

4205. <https://doi.org/10.1098/rspb.2012.1591>

- Aral, S., & Walker, D. (2011). Creating social contagion through viral product design: a randomized trial of peer influence in networks. *Management Science*, 57(9), 1623–1639. <https://doi.org/10.1287/mnsc.1110.1421>
- Archie, E. A., Tung, J., Clark, M., Altmann, J., & Alberts, S. C. (2014). Social affiliation matters: Both same-sex and opposite-sex relationships predict survival in wild female baboons. *Proceedings of the Royal Society B: Biological Sciences*, 281(1793), 20141261. <https://doi.org/10.1098/rspb.2014.1261>
- Asendorpf, J. B., & van Aken, M. (2003). Validity of Big Five personality judgments in childhood: a 9 year longitudinal study. *European Journal of Personality*, 17(1), 1–17. <https://doi.org/10.1002/per.460>
- Auersperg, A. M. I., von Bayern, A. M. P., Gajdon, G. K., Huber, L., & Kacelnik, A. (2011). Flexibility in Problem Solving and Tool Use of Kea and New Caledonian Crows in a Multi Access Box Paradigm. *PLoS ONE*, 6(6), e20231. <https://doi.org/10.1371/journal.pone.0020231>
- Backstrom, L., Huttenlocher, D., Kleinberg, J., & Lan, X. (2006). Group formation in large social networks. In *Proceedings of the 12th ACM SIGKDD international conference on knowledge discovery and data mining - KDD '06* (p. 44). New York, New York, USA: ACM Press. <https://doi.org/10.1145/1150402.1150412>
- Baddeley, A. (1996). Exploring the central executive. *The Quarterly Journal of Experimental Psychology Section A*, 49(1), 5–28. <https://doi.org/10.1080/713755608>
- Baer, M. (2010). The strength-of-weak-ties perspective on creativity: a comprehensive examination and extension. *The Journal of Applied Psychology*, 95(3), 592–601. <https://doi.org/10.1037/a0018761>
- Baer, M. (2012). Putting creativity to work: The implementation of creative ideas in organizations. *Academy of Management Journal*, 55(5), 1102–1119. <https://doi.org/10.5465/amj.2009.0470>
- Baer, M., Evans, K., Oldham, G. R., & Boasso, A. (2015). The social network side of individual innovation: A meta-analysis and path-analytic integration. *Organizational Psychology Review*, 1–33. <https://doi.org/10.1177/2041386614564105>
- Baer, M., & Oldham, G. R. (2006). The curvilinear relation between experienced creative time pressure and creativity: Moderating effects of openness to experience and support for creativity. *Journal of Applied Psychology*, 91(4), 963–970. <https://doi.org/10.1037/0021-9010.91.4.963>
- Bainbridge, D. (2010). *Teenagers: a natural history*. Portbello Books.

- Balasubramaniam, K. N., Berman, C. M., De Marco, A., Dittmar, K., Majolo, B., Ogawa, H., ... De Vries, H. (2013). Consistency of dominance rank order: A comparison of David's scores with I&SI and Bayesian methods in macaques. *American Journal of Primatology*, *75*(9), 959–971. <https://doi.org/10.1002/ajp.22160>
- Barbaranelli, C., Caprara, G. V., Rabasca, A., & Pastorelli, C. (2003). A questionnaire for measuring the Big Five in late childhood. *Personality and Individual Differences*, *34*(4), 645–664. [https://doi.org/10.1016/S0191-8869\(02\)00051-X](https://doi.org/10.1016/S0191-8869(02)00051-X)
- Barkow, J. H. (1987). Culture and the Evolutionary Process. *The Journal of Nervous and Mental Disease*, *175*(2), 125–126. <https://doi.org/10.1097/00005053-198702000-00018>
- Barrett, T. M., Davis, E. F., & Needham, A. (2007). Learning about tools in infancy. *Developmental Psychology*, *43*(2), 352–368. <https://doi.org/10.1037/0012-1649.43.2.352>
- Barrick, M. R., Stewart, G. L., & Piotrowski, M. (2002). Personality and job performance: test of the mediating effects of motivation among sales representatives. *The Journal of Applied Psychology*, *87*(1), 43–51.
- Bateson, P. (2014). Play, playfulness, creativity and innovation. *Animal Behavior and Cognition*, *2*(2), 99. <https://doi.org/10.12966/abc.05.02.2014>
- Bateson, P., & Martin, P. (2013). *Play, playfulness, creativity and innovation*. Cambridge University Press.
- Batey, M., & Furnham, A. (2006). Creativity, intelligence, and personality: A critical review of the scattered literature. *Genetic, Social, and General Psychology Monographs*, *132*(4), 355–429. <https://doi.org/10.3200/MONO.132.4.355-430>
- Beck, S. R., Apperly, I. A., Chappell, J., Guthrie, C., & Cutting, N. (2011). Making tools isn't child's play. *Cognition*, *119*(2), 301–306. <https://doi.org/10.1016/j.cognition.2011.01.003>
- Beck, S. R., Chappell, J., Apperly, I. A., & Cutting, N. (2012). Tool innovation may be a critical limiting step for the establishment of a rich tool-using culture: a perspective from child development. *The Behavioral and Brain Sciences*, *35*(4), 220–221. <https://doi.org/10.1017/S0140525X11001877>
- Beck, S. R., Williams, C., Cutting, N., Apperly, I. A., & Chappell, J. (2016). Individual differences in children's innovative problem-solving are not predicted by divergent thinking or executive functions. *Philosophical Transactions of the Royal Society of London B: Biological Sciences*, *371*(1690).
- Benson-Amram, S., Heinen, V. K., Gessner, A., Weldele, M. L., & Holekamp, K. E. (2014). Limited social learning

- of a novel technical problem by spotted hyenas. *Behavioural Processes*, 109(PB), 111–120.
<https://doi.org/10.1016/j.beproc.2014.09.019>
- Benson-Amram, S., & Holekamp, K. E. (2012). Innovative problem solving by wild spotted hyenas. *Proceedings of the Royal Society B: Biological Sciences*, 279(1744), 4087–4095. <https://doi.org/10.1098/rspb.2012.1450>
- Berl, R. E. W., & Hewlett, B. S. (2015). Cultural variation in the use of overimitation by the Aka and Ngandu of the Congo Basin. *PloS One*, 10(3), e0120180. <https://doi.org/10.1371/journal.pone.0120180>
- Bijvoet-van den Berg, S., & Hoicka, E. (2014). Individual differences and age-related changes in divergent thinking in toddlers and preschoolers. *Developmental Psychology*, 50(6), 1629–1639.
<https://doi.org/10.1037/a0036131>
- Biro, D., Inoue-Nakamura, N., Tonooka, R., Yamakoshi, G., Sousa, C., & Matsuzawa, T. (2003). Cultural innovation and transmission of tool use in wild chimpanzees: evidence from field experiments. *Animal Cognition*, 6(4), 213–223. <https://doi.org/10.1007/s10071-003-0183-x>
- Boesch, C. (2003). Is culture a golden barrier between human and chimpanzee? *Evolutionary Anthropology*, 12(2), 82–91. <https://doi.org/10.1002/evan.10106>
- Bonawitz, E., Shafto, P., Gweon, H., Goodman, N. D., Spelke, E., & Schulz, L. (2011). The double-edged sword of pedagogy: Instruction limits spontaneous exploration and discovery. *Cognition*, 120(3), 322–330.
<https://doi.org/10.1016/j.cognition.2010.10.001>
- Bond, R., & Smith, P. B. (1996). Culture and conformity: A meta-analysis of studies using Asch's (1952b, 1956) line judgment task. *Psychological Bulletin*, 119(1), 111–137. <https://doi.org/10.1037/0033-2909.119.1.111>
- Bonnie, K. E., & de Waal, F. B. M. (2006). Affiliation promotes the transmission of a social custom: handclasp grooming among captive chimpanzees. *Primates; Journal of Primatology*, 47(1), 27–34.
<https://doi.org/10.1007/s10329-005-0141-0>
- Borgatti, S. P., Everett, M. G., & Freeman, L. C. (2002). *Ucinet for Windows: Software for Social Network Analysis*. Boston: Analytic Technologies.
- Bouchard, J., & Thomas, J. (1969). Personality, problem-solving procedure, and performance in small groups. *Journal of Applied Psychology*, 53(1, Pt.2), 1–29. <https://doi.org/10.1037/h0026747>
- Box, H. O. (Hilary O. (1984). *Primate behaviour and social ecology*. Chapman and Hall. Retrieved from

https://books.google.com/books/about/Primate_behaviour_and_social_ecology.html?id=-aXwAAAAMAAJ

- Boyd, R., & Richerson, P. J. (1983). The cultural transmission of acquired variation: Effects on genetic fitness. *Journal of Theoretical Biology*, *100*(4), 567–596. [https://doi.org/10.1016/0022-5193\(83\)90324-7](https://doi.org/10.1016/0022-5193(83)90324-7)
- Boyd, R., & Richerson, P. J. (1985). *Culture and the evolutionary process*. University of Chicago Press.
- Boyd, R., Richerson, P. J., & Henrich, J. (2011). The cultural niche: Why social learning is essential for human adaptation. *Proceedings of the National Academy of Sciences*, *108*, 10918–10925. <https://doi.org/10.1073/pnas.1100290108>
- Brand, C. O., Brown, G. R., & Cross, C. P. (2018). Sex differences in the use of social information emerge under conditions of risk. *PeerJ*, *6*, e4190.
- Brandt, M. J., & Henry, P. J. (2012). Gender Inequality and Gender Differences in Authoritarianism. *Personality and Social Psychology Bulletin*, *38*(10), 1301–1315. <https://doi.org/10.1177/0146167212449871>
- Brosnan, S. F., & Hopper, L. M. (2014). Psychological limits on animal innovation. *Animal Behaviour*, *92*, 325–332. <https://doi.org/10.1016/j.anbehav.2014.02.026>
- Brosnan, S. F., Hopper, L. M., Richey, S., Freeman, H., Talbot, C. F., Gosling, S. D., ... Schapiro, S. J. (2015). Personality influences responses to inequity and contrast in chimpanzees. *Animal Behaviour*, *101*, 75–87. <https://doi.org/10.1016/J.ANBEHAV.2014.12.019>
- Brown, C., & Laland, K. N. (2003). Social learning in fishes: a review. *Fish and Fisheries*, *4*(3), 280–288. <https://doi.org/10.1046/j.1467-2979.2003.00122.x>
- Bruner, J. (1984). Vygotsky's zone of proximal development: The hidden agenda. *New Directions for Child and Adolescent Development*, *1984*(23), 93–97. <https://doi.org/10.1002/cd.23219842309>
- Burkart, J. M., Strasser, A., & Foglia, M. (2009). Trade-offs between social learning and individual innovativeness in common marmosets, *Callithrix jacchus*. *Animal Behaviour*, *77*(5), 1291–1301. <https://doi.org/10.1016/J.ANBEHAV.2009.02.006>
- Burns, A. L. J., Herbert-Read, J. E., Morrell, L. J., & Ward, A. J. W. (2012). Consistency of leadership in shoals of Mosquitofish (*Gambusia holbrooki*) in novel and in familiar environments. *PLoS ONE*, *7*(5), e36567. <https://doi.org/10.1371/journal.pone.0036567>
- Busse, T. V., & Mansfield, R. S. (1984). Selected personality traits and achievement in male scientists. *The Journal*

of Psychology: Interdisciplinary and Applied, 116(1), 117–131.
<https://doi.org/10.1080/00223980.1984.9923626>

- Buttelmann, D., Carpenter, M., Call, J., & Tomasello, M. (2013). Chimpanzees, Pan troglodytes, recognize successful actions, but fail to imitate them. *Animal Behaviour*, 86(4), 755–761.
<https://doi.org/10.1016/j.anbehav.2013.07.015>
- Call, J. (2015). Conservatism versus innovation: The great ape story. In *Animal Creativity and Innovation* (pp. 397–414). Elsevier. <https://doi.org/10.1016/B978-0-12-800648-1.00014-0>
- Call, J., Carpenter, M., & Tomasello, M. (2005). Copying results and copying actions in the process of social learning: chimpanzees (Pan troglodytes) and human children (Homo sapiens). *Animal Cognition*, 8(3), 151–163. <https://doi.org/10.1007/s10071-004-0237-8>
- Canfield, C. F., Saudino, K. J., & Ganea, P. A. (2015). The role of temperament in children’s reliance on others as sources of information. *Infant and Child Development*, 24(4), 435–451. <https://doi.org/10.1002/icd.1892>
- Cappella, E., Kim, H. Y., Neal, J. W., & Jackson, D. R. (2013). Classroom peer relationships and behavioral engagement in elementary school: the role of social network equity. *American Journal of Community Psychology*, 52(3–4), 367–379. <https://doi.org/10.1007/s10464-013-9603-5>
- Cappella, E., Neal, J. W., & Sahu, N. (2012). Children’s agreement on classroom social networks: Cross-level predictors in urban elementary schools. *Merrill-Palmer Quarterly*, 58(3), 285–313.
<https://doi.org/10.1353/mpq.2012.0017>
- Carpenter, M., & Call, J. (2009). Comparing the imitative skills of children and nonhuman apes. *Revue de Primatologie*, (1). <https://doi.org/10.4000/primatologie.263>
- Carr, K., Kendal, R. L., & Flynn, E. G. (2015). Imitate or innovate? Children’s innovation is influenced by the efficacy of observed behaviour. *Cognition*, 142, 322–332. <https://doi.org/10.1016/j.cognition.2015.05.005>
- Carr, K., Kendal, R. L., & Flynn, E. G. (2016). Eureka!: what is innovation, how does It develop, and who does it? *Child Development*, 87(5), 1505–1519. <https://doi.org/10.1111/cdev.12549>
- Carter, A. J., Feeney, W. E., Marshall, H. H., Cowlshaw, G., & Heinsohn, R. (2013). Animal personality: What are behavioural ecologists measuring? *Biological Reviews*, 88(2), 465–475. <https://doi.org/10.1111/brv.12007>
- Carter, A. J., Marshall, H. H., Heinsohn, R., & Cowlshaw, G. (2012). Evaluating animal personalities: Do observer

- assessments and experimental tests measure the same thing? *Behavioral Ecology and Sociobiology*, 66(1), 153–160. <https://doi.org/10.1007/s00265-011-1263-6>
- Carter, A. J., Marshall, H. H., Heinsohn, R., & Cowlshaw, G. (2013). Personality predicts decision making only when information is unreliable. *Animal Behaviour*, 86(3), 633–639. <https://doi.org/10.1016/j.anbehav.2013.07.009>
- Carter, A. J., Marshall, H. H., Heinsohn, R., & Cowlshaw, G. (2014). Personality predicts the propensity for social learning in a wild primate. *PeerJ*, 2, e283. <https://doi.org/10.7717/peerj.283>
- Carter, A. J., Tico, M. T., & Cowlshaw, G. (2016). Sequential phenotypic constraints on social information use in wild baboons. *eLife*, 5(April 2016), 1–21. <https://doi.org/10.7554/eLife.13125>
- Cattuto, C., Van den Broeck, W., Barrat, A., Colizza, V., Pinton, J.-F., & Vespignani, A. (2010). Dynamics of person-to-person interactions from distributed RFID sensor networks. *PLoS ONE*, 5(7), e11596. <https://doi.org/10.1371/journal.pone.0011596>
- Centola, D. (2010). The spread of behavior in an online social network experiment. *Science (New York, N.Y.)*, 329(5996), 1194–1197. <https://doi.org/10.1126/science.1185231>
- Chamorro-Premuzic, T. (2006). Creativity versus conscientiousness: which is a better predictor of student performance? *Applied Cognitive Psychology*, 20(4), 521–531. <https://doi.org/10.1002/acp.1196>
- Chamorro-Premuzic, T., Furnham, A., & Lewis, M. (2007). Personality and approaches to learning predict preference for different teaching methods. *Learning and Individual Differences*, 17(3), 241–250. <https://doi.org/10.1016/j.lindif.2006.12.001>
- Chamorro-Premuzic, T., & Reichenbacher, L. (2008). Effects of personality and threat of evaluation on divergent and convergent thinking. *Journal of Research in Personality*, 42, 1095–1101. <https://doi.org/10.1016/j.jrp.2007.12.007>
- Chapman, B. P., Duberstein, P. R., Sørensen, S., & Lyness, J. M. (2007). Gender differences in five factor model personality traits in an elderly cohort: extension of robust and surprising findings to an older generation. *Personality and Individual Differences*, 43(06), 1594–1603. <https://doi.org/10.1016/j.paid.2007.04.028>
- Chappell, J., Cutting, N., Apperly, I. A., & Beck, S. R. (2013). The development of tool manufacture in humans: what helps young children make innovative tools? *Philosophical Transactions of the Royal Society B*:

Biological Sciences, 368(1630), 20120409–20120409. <https://doi.org/10.1098/rstb.2012.0409>

- Chartrand, T. L., & Bargh, J. A. (1999). The chameleon effect: the perception-behavior link and social interaction. *Journal of Personality and Social Psychology*, 76(6), 893–910.
- Christakis, N. A., & Fowler, J. H. (2008). The collective dynamics of smoking in a large social network. *The New England Journal of Medicine*, 358(21), 2249–2258. <https://doi.org/10.1056/NEJMsa0706154>
- Christakis, N. A., & Fowler, J. H. (2010). *Connected: The amazing power of social networks and how they shape our lives*. New York: HarperPress.
- Chudek, M., Baron, A. S., & Birch, S. (2016). Unselective overimitators: the evolutionary implications of children's indiscriminate copying of successful and prestigious models. *Child Development*, 87(3), 782–794. <https://doi.org/10.1111/cdev.12529>
- Claidière, N., Messer, E. J. E., Hoppitt, W., & Whiten, A. (2013). Diffusion dynamics of socially learned foraging techniques in squirrel monkeys. *Current Biology*, 23(13), 1251–1255. <https://doi.org/10.1016/j.cub.2013.05.036>
- Clark, F. (2017). Cognitive enrichment and welfare: Current approaches and future directions. *Animal Behavior and Cognition*, 4(1), 52–71. <https://doi.org/10.12966/abc.05.02.2017>
- Clay, Z., & Tennie, C. (2017). Is overimitation a uniquely human phenomenon? Insights from human children as compared to bonobos. *Child Development*. <https://doi.org/10.1111/cdev.12857>
- Clegg, J. M., & Legare, C. H. (2016). A cross-cultural comparison of children's imitative flexibility. *Developmental Psychology*. <https://doi.org/10.1017/CBO9781107415324.004>
- Clegg, J. M., Wen, N. J., & Legare, C. H. (2017). Is non-conformity WEIRD? Cultural variation in adults' beliefs about children's competency and conformity. *Journal of Experimental Psychology: General*, 146(3), 428–441. <https://doi.org/10.1037/xge0000275>
- Cole, C. B., Nikpay, M., Lau, P., Stewart, A. F. R., Davies, R. W., Wells, G. A., ... McPherson, R. (2014). Adiposity significantly modifies genetic risk for dyslipidemia. *Journal of Lipid Research*, 55(11), 2416–2422. <https://doi.org/10.1194/jlr.P052522>
- Cook, J. L., den Ouden, H. E. M., Heyes, C. M., & Cools, R. (2014). The social dominance paradox. *Current Biology*, 24(23), 2812–2816. <https://doi.org/10.1016/j.cub.2014.10.014>

- Corriveau, K. H., DiYanni, C. J., Clegg, J. M., Min, G., Chin, J., & Nasrini, J. (2017). Cultural differences in the imitation and transmission of inefficient actions. *Journal of Experimental Child Psychology*, *161*, 1–18. <https://doi.org/10.1016/j.jecp.2017.03.002>
- Corriveau, K. H., Harris, P. L., Meins, E., Fernyhough, C., Arnott, B., Elliott, L., ... de Rosnay, M. (2009). Young children's trust in their mother's claims: Longitudinal links with attachment security in infancy. *Child Development*, *80*(3), 750–761. <https://doi.org/10.1111/j.1467-8624.2009.01295.x>
- Costa, P. T., Terracciano, A., & McCrae, R. R. (2001). Gender differences in personality traits across cultures: Robust and surprising findings. *Journal of Personality and Social Psychology*, *81*(2), 322–331. <https://doi.org/10.1037/0022-3514.81.2.322>
- Coussi-Korbel, S., & Frigaszy, D. (1995). On the relation between social dynamics and social learning. *Animal Behaviour*, *50*(6), 1441–1453. [https://doi.org/10.1016/0003-3472\(95\)80001-8](https://doi.org/10.1016/0003-3472(95)80001-8)
- Croft, D. P., Madden, J. R., Franks, D. W., & James, R. (2011). Hypothesis testing in animal social networks. *Trends in Ecology and Evolution*, *26*(10), 502–507. <https://doi.org/10.1016/j.tree.2011.05.012>
- Cronin, K. A., Jacobson, S. L., Bonnie, K. E., & Hopper, L. M. (2017). Studying primate cognition in a social setting to improve validity and welfare: a literature review highlighting successful approaches. *PeerJ*, *5*, e3649. <https://doi.org/10.7717/peerj.3649>
- Cross, C. P., Brown, G. R., Morgan, T. J. H., & Laland, K. N. (2017). Sex differences in confidence influence patterns of conformity. *British Journal of Psychology*, *108*(4), 655–667. <https://doi.org/10.1111/bjop.12232>
- Cutting, N., Apperly, I. A., & Beck, S. R. (2011). Why do children lack the flexibility to innovate tools? *Journal of Experimental Child Psychology*, *109*(4), 497–511. <https://doi.org/10.1016/j.jecp.2011.02.012>
- Cutting, N., Apperly, I. A., Chappell, J., & Beck, S. R. (2014). The puzzling difficulty of tool innovation: Why can't children piece their knowledge together? *Journal of Experimental Child Psychology*, *125*, 110–117. <https://doi.org/10.1016/j.jecp.2013.11.010>
- Dall, S. R. X., Houston, A. I., & McNamara, J. M. (2004). The behavioural ecology of personality: Consistent individual differences from an adaptive perspective. *Ecology Letters*, *7*(8), 734–739. <https://doi.org/10.1111/j.1461-0248.2004.00618.x>
- Davis, M. A. (2009). Understanding the relationship between mood and creativity: A meta-analysis. *Organizational*

Behavior and Human Decision Processes, 108(1), 25–38. <https://doi.org/10.1016/j.obhdp.2008.04.001>

- Davis, S. J., Vale, G., Schapiro, S. J., Lambeth, S. P., & Whiten, A. (2016). Foundations of cumulative culture in apes: Improved foraging efficiency through relinquishing and combining witnessed behaviours in chimpanzees (*Pan troglodytes*). *Scientific Reports*, 6, 35953. <https://doi.org/10.1038/srep35953>
- Day, R. L., Coe, R. L., Kendal, J., & Laland, K. N. (2003). Neophilia, innovation and social learning: a study of intergeneric differences in callitrichid monkeys. *Animal Behaviour*, 65(3), 559–571. <https://doi.org/10.1006/anbe.2003.2074>
- de Waal, F. B. M. (1998). No imitation without identification. *Behavioral and Brain Sciences*, 21(5), 689–689. <https://doi.org/10.1017/S0140525X98271743>
- de Waal, F. B. M. (2000). *Chimpanzee politics: Power and sex among apes*. Johns Hopkins University Press. <https://doi.org/10.1037/022265>
- de Waal, F. B. M. (2001). *The ape and the sushi master: cultural reflections by a primatologist*. Basic Books.
- Dean, L. G., Kendal, R. L., Schapiro, S. J., Thierry, B., & Laland, K. N. (2012). Identification of the social and cognitive processes underlying human cumulative culture. *Science (New York, N.Y.)*, 335(6072), 1114–1118. <https://doi.org/10.1126/science.1213969>
- Dean, L. G., Vale, G., Laland, K. N., Flynn, E. G., & Kendal, R. L. (2014). Human cumulative culture: a comparative perspective. *Biological Reviews of the Cambridge Philosophical Society*, 89(2), 284–301. <https://doi.org/10.1111/brv.12053>
- Dennissen, J. J. A., Asendorpf, J. B., & Van Aken, M. A. G. (2007). Childhood personality predicts long-term trajectories of shyness and aggressiveness in the context of demographic transitions in emerging adulthood. *Journal of Personality*, 76(1), 67–100. <https://doi.org/10.1111/j.1467-6494.2007.00480.x>
- DePasquale, C., Wagner, T., Archard, G. A., Ferguson, B., & Braithwaite, V. A. (2014). Learning rate and temperament in a high predation risk environment. *Oecologia*, 176(3), 661–667. <https://doi.org/10.1007/s00442-014-3099-z>
- Diedrich, J., Benedek, M., Jauk, E., & Neubauer, A. C. (2015). Are creative ideas novel and useful? *Psychology of Aesthetics, Creativity, and the Arts*, 9(1), 35–40. <https://doi.org/10.1037/a0038688>
- Dindo, M., Stoinski, T. S., & Whiten, A. (2011). Observational learning in orangutan cultural transmission chains.

Biology Letters, 7(2). <https://doi.org/10.1098/rsbl.2010.0637>

- Dindo, M., Thierry, B., & Whiten, A. (2008). Social diffusion of novel foraging methods in brown capuchin monkeys (*Cebus apella*). *Proceedings. Biological Sciences / The Royal Society*, 275(1631), 187–193. <https://doi.org/10.1098/rspb.2007.1318>
- Dingemanse, N. J., & Wolf, M. (2010). Recent models for adaptive personality differences: a review. *Philosophical Transactions of the Royal Society of London B: Biological Sciences*, 365(1560). Retrieved from <http://rstb.royalsocietypublishing.org/content/365/1560/3947>
- Donnellan, M. B., & Robins, R. W. (2010). Resilient, overcontrolled, and undercontrolled personality types: Issues and controversies. *Social and Personality Psychology Compass*, 4(11), 1070–1083. <https://doi.org/10.1111/j.1751-9004.2010.00313.x>
- Dufour, V., Sueur, C., Whiten, A., & Buchanan-Smith, H. M. (2011). The impact of moving to a novel environment on social networks, activity and wellbeing in two new world primates. *American Journal of Primatology*, 73(8), 802–811. <https://doi.org/10.1002/ajp.20943>
- Dutton, D. M. (2008). Subjective assessment of chimpanzee (*Pan troglodytes*) personality: reliability and stability of trait ratings. *Primates*, 49(4), 253–259. <https://doi.org/10.1007/s10329-008-0094-1>
- Efferson, C., Lalive, R., Richerson, P., McElreath, R., & Lubell, M. (2008). Conformists and mavericks: the empirics of frequency-dependent cultural transmission. *Evolution and Human Behavior*, 29(1), 56–64. <https://doi.org/10.1016/j.evolhumbehav.2007.08.003>
- Evans, C. L., Laland, K. N., Carpenter, M., & Kendal, R. L. (2017). Selective copying of the majority suggests children are broadly “optimal-” rather than “over-” imitators. *Developmental Science*, e12637. <https://doi.org/10.1111/desc.12637>
- Eysenck, H. (1977). *The Biological Basis of Personality*. Taylor and Francis.
- Fagot, J., & De Lillo, C. (2011). A comparative study of working memory: Immediate serial spatial recall in baboons (*Papio papio*) and humans. *Neuropsychologia*, 49(14), 3870–3880. <https://doi.org/10.1016/j.neuropsychologia.2011.10.003>
- Farine, D. R., Aplin, L. M., Sheldon, B. C., & Hoppitt, W. (2015). Interspecific social networks promote information transmission in wild songbirds. *Proceedings. Biological Sciences / The Royal Society*, 282(1803).

<https://doi.org/10.1098/rspb.2014.2804>

- Farmer, T. W., & Farmer, E. M. Z. (1996). Social relationships of students with exceptionalities in mainstream classrooms: social networks and homophily. *Exceptional Children*, 62(5), 431–450. <https://doi.org/10.1177/001440299606200504>
- Feiler, D. C., & Kleinbaum, A. M. (2015). Popularity, similarity, and the network extraversion bias. *Psychological Science*, 26(5), 593–603. <https://doi.org/10.1177/0956797615569580>
- Feist, G. J. (1998). A meta-analysis of personality in scientific and artistic creativity. *Personality and Social Psychology Review*, 2(4), 290–309. https://doi.org/10.1207/s15327957pspr0204_5
- Fishman, I., Ng, R., & Bellugi, U. (2011). Do extraverts process social stimuli differently from introverts? *Cognitive Neuroscience*, 2(2), 67–73. <https://doi.org/10.1080/17588928.2010.527434>
- Fleming, L., & Waguespack, D. M. (2007). Brokerage, boundary spanning, and leadership in open innovation communities. *Organization Science*, 18(2), 165–180. <https://doi.org/10.1287/orsc.1060.0242>
- Flynn, E. G. (2008). Investigating children as cultural magnets: do young children transmit redundant information along diffusion chains? *Philosophical Transactions of the Royal Society of London. Series B, Biological Sciences*, 363(1509), 3541–3551. <https://doi.org/10.1098/rstb.2008.0136>
- Flynn, E. G., Turner, C., & Giraldeau, L.-A. (2016). Selectivity in social and asocial learning: investigating the prevalence, effect and development of young children’s learning preferences. *Philosophical Transactions of the Royal Society of London. Series B, Biological Sciences*, 371(1690), 688–699. <https://doi.org/10.1098/rstb.2015.0189>
- Flynn, E. G., & Whiten, A. (2008). Cultural transmission of tool use in young children: A diffusion chain study. *Social Development*, 17(3), 699–718. <https://doi.org/10.1111/j.1467-9507.2007.00453.x>
- Flynn, E. G., & Whiten, A. (2010). Studying children’s social learning experimentally “in the wild”. *Learning & Behavior*, 38(3), 284–296. <https://doi.org/10.3758/LB.38.3.284>
- Flynn, E. G., & Whiten, A. (2012). Experimental “microcultures” in young children: identifying biographic, cognitive, and social predictors of information transmission. *Child Development*, 83(3), 911–925. <https://doi.org/10.1111/j.1467-8624.2012.01747.x>
- Foster, M. A., Lambert, R., Abbott-Shim, M., McCarty, F., & Franze, S. (2005). A model of home learning

- environment and social risk factors in relation to children's emergent literacy and social outcomes. *Early Childhood Research Quarterly*, 20(1), 13–36. <https://doi.org/10.1016/J.ECRESQ.2005.01.006>
- Fournet, J., Barrat, A., Jr, I. L., Koopman, J., Monto, A., Fox, J., ... Shkedy, Z. (2014). Contact Patterns among High School Students. *PLoS ONE*, 9(9), e107878. <https://doi.org/10.1371/journal.pone.0107878>
- Fowler, J. H., & Christakis, N. A. (2008). Dynamic spread of happiness in a large social network: longitudinal analysis over 20 years in the Framingham Heart Study. *BMJ*, 337(2), a2338–a2338. <https://doi.org/10.1136/bmj.a2338>
- Fox, E. A., van Schaik, C. P., Sitompul, A., & Wright, D. N. (2004). Intra-and interpopulational differences in orangutan (*Pongo pygmaeus*) activity and diet: Implications for the invention of tool use. *American Journal of Physical Anthropology*, 125(2), 162–174. <https://doi.org/10.1002/ajpa.10386>
- Franke, N., & Shah, S. (2003). How communities support innovative activities: an exploration of assistance and sharing among end-users. *Research Policy*, 32(1), 157–178. [https://doi.org/10.1016/S0048-7333\(02\)00006-9](https://doi.org/10.1016/S0048-7333(02)00006-9)
- Freeman, H., Brosnan, S. F., Hopper, L. M., Lambeth, S. P., Schapiro, S. J., & Gosling, S. D. (2013). Developing a comprehensive and comparative questionnaire for measuring personality in chimpanzees using a simultaneous top-down/bottom-up design. *American Journal of Primatology*, 75(10), 1042–1053. <https://doi.org/10.1002/ajp.22168>
- Freeman, H., Gosling, S. D., & Schapiro, S. J. (2011). Comparison of methods for assessing personality in nonhuman primates. In *Personality and Temperament in Nonhuman Primates* (pp. 17–40). New York, NY: Springer New York. https://doi.org/10.1007/978-1-4614-0176-6_2
- Freitag, M., & Bauer, P. C. (2015). Personality traits and the propensity to trust friends and strangers. *Social Science Journal*, (January). <https://doi.org/10.1016/j.soscij.2015.12.002>
- Frick, A., Clément, F., & Gruber, T. (2017). Evidence for a sex effect during overimitation: boys copy irrelevant modelled actions more than girls across cultures. *Royal Society Open Science*, 4(12), 170367. <https://doi.org/10.1098/rsos.170367>
- Funkhouser, J. A., Mayhew, J. A., & Mulcahy, J. B. (2018). Social network and dominance hierarchy analyses at Chimpanzee Sanctuary Northwest. *PLOS ONE*, 13(2), e0191898. <https://doi.org/10.1371/journal.pone.0191898>

- Furnham, A., & Bachtiar, V. (2008). Personality and intelligence as predictors of creativity. *Personality and Individual Differences, 45*(7), 613–617. <https://doi.org/10.1016/j.paid.2008.06.023>
- Galef, B. G., & Laland, K. N. (2005). Social learning in animals: empirical studies and theoretical models. *BioScience, 55*(6), 489. [https://doi.org/10.1641/0006-3568\(2005\)055\[0489:SLIAES\]2.0.CO;2](https://doi.org/10.1641/0006-3568(2005)055[0489:SLIAES]2.0.CO;2)
- Garai, C., Weiss, A., Arnaud, C., & Furuichi, T. (2016). Personality in wild bonobos (*Pan paniscus*). *American Journal of Primatology, 78*(11), 1178–1189. <https://doi.org/10.1002/ajp.22573>
- García-Arenzana, N., Navarrete-Muñoz, E. M., Lope, V., Moreo, P., Vidal, C., Laso-Pablos, S., ... Pollán, M. (2014). Calorie intake, olive oil consumption and mammographic density among Spanish women. *International Journal of Cancer, 134*(8), 1916–1925. <https://doi.org/10.1002/ijc.28513>
- Gartstein, M. A., & Rothbart, M. K. (2003). Studying infant temperament via the Revised Infant Behavior Questionnaire. *Infant Behavior and Development, 26*(1), 64–86. [https://doi.org/10.1016/S0163-6383\(02\)00169-8](https://doi.org/10.1016/S0163-6383(02)00169-8)
- Gauthier, T. D. (2001). Detecting trends using Spearman's rank correlation coefficient. *East, 2*(4), 359–362. <https://doi.org/10.1006/enfo.2001.0061>
- George, J. M., & Zhou, J. (2001). When openness to experience and conscientiousness are related to creative behavior: An interactional approach. *Journal of Applied Psychology, 86*(3), 513–524. <https://doi.org/10.1037/0021-9010.86.3.513>
- German, T. P., & Defeyter, M. A. (2000). Immunity to functional fixedness in young children. *Psychonomic Bulletin & Review, 7*(4), 707–712. <https://doi.org/10.3758/BF03213010>
- Gerris, J. R. M., Delgado, M. M., & Oud, J. H. L. (2010). Big-Five personality factors and interpersonal trust in established marriages. *Family Science, 1*(1), 48–62. <https://doi.org/10.1080/19424620903424094>
- Gest, S. D. (2006). Teacher reports of children's friendships and social groups: agreement with peer reports and implications for studying peer similarity. *Social Development, 15*(2), 248–259. <https://doi.org/10.1046/j.1467-9507.2006.00339.x>
- Gest, S. D., Farmer, T. W., Cairns, B. D., & Xie, H. (2003). Identifying children's peer social networks in school classrooms: Links between peer reports and observed interactions. *Social Development, 12*(4), 513–529. <https://doi.org/10.1111/1467-9507.00246>

- Ghirlanda, S., & Lind, J. (2017). 'Aesop's fable' experiments demonstrate trial-and-error learning in birds, but no causal understanding. *Animal Behaviour*, *123*, 239–247. <https://doi.org/10.1016/J.ANBEHAV.2016.10.029>
- Gjerde, P. F., & Cardilla, K. (2009). Developmental implications of openness to experience in preschool children: gender differences in young adulthood. *Developmental Psychology*, *45*(5), 1455–1464. <https://doi.org/10.1037/A0016714>
- Goodall, J. (1986). *The chimpanzees of Gombe: patterns of behavior*. Belknap Press of Harvard University Press.
- Gosling, S. D. (2001). From mice to men: what can we learn about personality from animal research? *Psychological Bulletin*, *127*(1), 45–86.
- Graziano, W. G., & Ward, D. (1992). Probing the Big Five in adolescence: Personality and adjustment during a developmental transition. *Journal of Personality*, *60*(2), 425–439. <https://doi.org/10.1111/j.1467-6494.1992.tb00979.x>
- Griffin, A. S., & Guez, D. (2014). Innovation and problem solving: a review of common mechanisms. *Behavioural Processes*, *109*, 121–134. <https://doi.org/10.1016/j.beproc.2014.08.027>
- Griffin, A. S., Netto, K., & Peneaux, C. (2017). Neophilia, innovation and learning in an urbanized world: a critical evaluation of mixed findings. *Current Opinion in Behavioral Sciences*. <https://doi.org/10.1016/j.cobeha.2017.01.004>
- Gross, M. (2016). Chimpanzees, our cultured cousins. *Current Biology*, *26*, R83–R85. <https://doi.org/10.1016/j.cub.2016.01.043>
- Gruber, T. (2016). Great apes do not learn novel tool use easily: conservatism, functional fixedness, or cultural influence? *International Journal of Primatology*, *37*(2), 296–316. <https://doi.org/10.1007/s10764-016-9902-4>
- Gruber, T., Clay, Z., & Zuberbühler, K. (2010). A comparison of bonobo and chimpanzee tool use: evidence for a female bias in the Pan lineage. *Animal Behaviour*, *80*(6), 1023–1033. <https://doi.org/10.1016/j.anbehav.2010.09.005>
- Gruber, T., Muller, M. N., Strimling, P., Wrangham, R., & Zuberbühler, K. (2009). Wild chimpanzees rely on cultural knowledge to solve an experimental honey acquisition task. *Current Biology*, *19*(21), 1806–1810. <https://doi.org/10.1016/j.cub.2009.08.060>

- Gruber, T., Zuberbühler, K., & Neumann, C. (2016). Travel fosters tool use in wild chimpanzees. *ELife*, 5, 93–103. <https://doi.org/10.7554/eLife.16371>
- Guignard, J.-H., Kermarrec, S., & Tordjman, S. (2016). Relationships between intelligence and creativity in gifted and non-gifted children. *Learning and Individual Differences*, 52, 209–215. <https://doi.org/10.1016/J.LINDIF.2015.07.006>
- Guilford, J. P. (1967). *The nature of human intelligence*. McGraw-Hill.
- Guillette, L. M., Baron, D. M., Sturdy, C. B., & Spetch, M. L. (2016). Fast- and slow-exploring pigeons differ in how they use previously learned rules. *Behavioural Processes*, (August), 6–15. <https://doi.org/10.1016/j.beproc.2016.07.006>
- Guillette, L. M., Naguib, M., & Griffin, A. S. (2017). Individual differences in cognition and personality. *Behavioural Processes*, 134, 1–3. <https://doi.org/10.1016/j.beproc.2016.12.001>
- Guillette, L. M., Reddon, A. R., Hurd, P. L., & Sturdy, C. B. (2009). Exploration of a novel space is associated with individual differences in learning speed in black-capped chickadees, *Poecile atricapillus*. *Behavioural Processes*, 82(3), 265–270. <https://doi.org/10.1016/j.beproc.2009.07.005>
- Gunhold, T., Whiten, A., & Bugnyar, T. (2014). Video demonstrations seed alternative problem-solving techniques in wild common marmosets. *Biology Letters*, 10(9), 3477–3488. <https://doi.org/10.1098/rsbl.2014.0439>
- Gurven, M., von Rueden, C., Massenkoff, M., Kaplan, H., & Lero Vie, M. (2013). How universal is the Big Five? Testing the five-factor model of personality variation among forager–farmers in the Bolivian Amazon. *Journal of Personality and Social Psychology*, 104(2), 354–370. <https://doi.org/10.1037/a0030841>
- Hanus, D., Mendes, N., Tennie, C., & Call, J. (2011). Comparing the performances of apes (*Gorilla gorilla*, *Pan troglodytes*, *Pongo pygmaeus*) and human children (*Homo sapiens*) in the floating peanut task. *PloS One*, 6(6), e19555. <https://doi.org/10.1371/journal.pone.0019555>
- Harris, P. L. (2007). Trust. *Developmental Science*, 10(1), 135–138. <https://doi.org/10.1111/j.1467-7687.2007.00575.x>
- Haslam, M. (2013). “Captive bias” in animal tool use and its implications for the evolution of hominin technology. *Philosophical Transactions of the Royal Society of London. Series B, Biological Sciences*, 368(1630), 20120421. <https://doi.org/10.1098/rstb.2012.0421>

- Haun, D. B. M., Rekers, Y., & Tomasello, M. (2014). Children conform to the behavior of peers; other great apes stick with what they know. *Psychological Science*, 25(12), 2160–2167. <https://doi.org/10.1177/0956797614553235>
- Helson, R. (1977). The creative spectrum of authors of fantasy. *Journal of Personality*, 45(2), 310–326.
- Henrich, J. (2015). *The secret of our success: How culture is driving human evolution, domesticating our species, and making us smarter*. Princeton University Press.
- Henrich, J., Heine, S. J., & Norenzayan, A. (2010). The weirdest people in the world? *Behavioral and Brain Sciences*, 33(2–3), 61–83. <https://doi.org/10.1017/S0140525X0999152X>
- Herrelko, E. S., Vick, S. J., & Buchanan-Smith, H. M. (2012). Cognitive research in zoo-housed chimpanzees: Influence of personality and impact on welfare. *American Journal of Primatology*, 74(9), 828–840. <https://doi.org/10.1002/ajp.22036>
- Herrmann, P. A., Legare, C. H., Harris, P. L., & Whitehouse, H. (2013). Stick to the script: The effect of witnessing multiple actors on children's imitation. *Cognition*, 129(3), 536–543. <https://doi.org/10.1016/j.cognition.2013.08.010>
- Hewlett, B. S., Fouts, H. N., & Boyette, A. H. (2011). Social learning among Congo Basin hunter-gatherers. *Philosophical Transactions of the Royal Society B-Biological Sciences: Biological Sciences*, 366(1567). <https://doi.org/366/1567/1168> [pii]r10.1098/rstb.2010.0373
- Heyes, C. (2011). Automatic imitation. *Psychological Bulletin*, 137(3), 463–483. <https://doi.org/10.1037/a0022288>
- Heyes, C. M. (1994). Social learning in animals: categories and mechanisms. *Biological Reviews of the Cambridge Philosophical Society*, 69(2), 207–231. Retrieved from <http://www.ncbi.nlm.nih.gov/pubmed/8054445>
- Heyes, C. M. (2016). Blackboxing: social learning strategies and cultural evolution. *Philosophical Transactions of the Royal Society B: Biological Sciences*, 371(1693). <https://doi.org/10.1098/rstb.2015.0369>
- Higdon, R., van Belle, G., & Kolker, E. (2008). A note on the false discovery rate and inconsistent comparisons between experiments. *Bioinformatics*, 24(10), 1225–1228. <https://doi.org/10.1093/bioinformatics/btn120>
- Hilbrink, E. E., Sakkalou, E., Ellis-Davies, K., Fowler, N. C., & Gattis, M. (2013). Selective and faithful imitation at 12 and 15 months. *Developmental Science*, 16(6), 828–840. <https://doi.org/10.1111/desc.12070>
- Hirata, S., & Morimura, N. (2000). Naive chimpanzees' (Pan troglodytes) observation of experienced conspecifics

in a tool-using task. *Journal of Comparative Psychology*, *114*(3), 291–296. <https://doi.org/10.1037/0735-7036.114.3.291>

Hirata, S., Morimura, N., & Houki, C. (2009). How to crack nuts: Acquisition process in captive chimpanzees (*Pan troglodytes*) observing a model. *Animal Cognition*, *12*. <https://doi.org/10.1007/s10071-009-0275-3>

Hobaiter, C., Poisot, T., Zuberbühler, K., Hoppitt, W., & Gruber, T. (2014). Social network analysis shows direct evidence for social transmission of tool use in wild chimpanzees. *PLoS Biology*, *12*(9), e1001960. <https://doi.org/10.1371/journal.pbio.1001960>

Hofstede, G., & McCrae, R. R. (2004). Personality and culture revisited: Linking traits and dimensions of culture. *Cross-Cultural Research*, *38*(1), 52–88. <https://doi.org/10.1177/1069397103259443>

Hopper, L. M. (2016). The individual and social drivers of primate innovationx. <https://doi.org/10.7287/PEERJ.PREPRINTS.2276V1>

Hopper, L. M., Flynn, E. G., Wood, L. A., & Whiten, A. (2010). Observational learning of tool use in children: Investigating cultural spread through diffusion chains and learning mechanisms through ghost displays. *Journal of Experimental Child Psychology*, *106*(1), 82–97. <https://doi.org/10.1016/j.jecp.2009.12.001>

Hopper, L. M., Lambeth, S. P., & Schapiro, S. J. (2012). An evaluation of the efficacy of video displays for use with chimpanzees (*Pan troglodytes*). *American Journal of Primatology*, *74*(5), 442–449. <https://doi.org/10.1002/ajp.22001>

Hopper, L. M., Lambeth, S. P., Schapiro, S. J., & Whiten, A. (2015). The importance of witnessed agency in chimpanzee social learning of tool use. *Behavioural Processes*, *112*, 120–129. <https://doi.org/10.1016/j.beproc.2014.10.009>

Hopper, L. M., Price, S. a, Freeman, H., Lambeth, S. P., Schapiro, S. J., & Kendal, R. L. (2014). Influence of personality, age, sex, and estrous state on chimpanzee problem-solving success. *Animal Cognition*, *17*(4), 835–847. <https://doi.org/10.1007/s10071-013-0715-y>

Hopper, L. M., Schapiro, S. J., Lambeth, S. P., & Brosnan, S. F. (2011). Chimpanzees' socially maintained food preferences indicate both conservatism and conformity. *Animal Behaviour*, *81*(6), 1195–1202. <https://doi.org/10.1016/j.anbehav.2011.03.002>

Hopper, L. M., Spitari, A., Lambeth, S., Schapiro, S. J., Horner, V., & Whiten, A. (2007). Experimental studies of

- traditions and underlying transmission processes in chimpanzees. *Animal Behaviour*, 73(6), 1021–1032. <https://doi.org/10.1016/j.anbehav.2006.07.016>
- Horner, V., Proctor, D., Bonnie, K. E., Whiten, A., & de Waal, F. B. M. (2010). Prestige affects cultural learning in chimpanzees. *PloS One*, 5(5), e10625. <https://doi.org/10.1371/journal.pone.0010625>
- Horner, V., & Whiten, A. (2004). Causal knowledge and imitation/emulation switching in chimpanzees (Pan troglodytes) and children (Homo sapiens). *Animal Cognition*, 8(3), 164–181. <https://doi.org/10.1007/s10071-004-0239-6>
- Horner, V., Whiten, A., Flynn, E., & de Waal, F. B. M. (2006). Faithful replication of foraging techniques along cultural transmission chains by chimpanzees and children. *Proceedings of the National Academy of Sciences*, 103(37), 13878–13883. <https://doi.org/10.1073/pnas.0606015103>
- Hosseini-Kamkar, N., & Morton, J. B. (2014). Sex differences in self-regulation: an evolutionary perspective. *Frontiers in Neuroscience*, 8, 233. <https://doi.org/10.3389/fnins.2014.00233>
- Howard, L. H., Wagner, K. E., Woodward, A. L., Ross, S. R., & Hopper, L. M. (2017). Social models enhance apes' memory for novel events. *Scientific Reports*, 7, 40926. <https://doi.org/10.1038/srep40926>
- Howard, L. H., Wagner, K. E., Woodward, A. L., Ross, S. R., Hopper, L. M., Whiten, A., ... Wagner, K. E. (2017). Social Models Enhance Apes' Memory for Novel Events. *Scientific Reports*, 7. <https://doi.org/10.1038/srep40926>
- Inoue-Nakamura, N., & Matsuzawa, T. (1997). Development of stone tool use by wild chimpanzees (Pan troglodytes). *Journal of Comparative Psychology*, 111(2), 159–173. <https://doi.org/10.1037/0735-7036.111.2.159>
- Jaeggi, A. V., Dunkel, L. P., van Noordwijk, M. A., Wich, S. A., Sura, A. A. L., & van Schaik, C. P. (2010). Social learning of diet and foraging skills by wild immature Bornean orangutans: Implications for culture. *American Journal of Primatology*, 72(1). <https://doi.org/10.1002/ajp.20752>
- Jauk, E., Benedek, M., Dunst, B., & Neubauer, A. C. (2013). The relationship between intelligence and creativity: New support for the threshold hypothesis by means of empirical breakpoint detection. *Intelligence*, 41(4), 212–221. <https://doi.org/10.1016/j.intell.2013.03.003>
- Jensen-Campbell, L. A., Adams, R., Perry, D. G., Workman, K. A., Furdella, J. Q., Egan, S. K., & Perry, D. G.

- (2002). Agreeableness, extraversion, and peer relations in early adolescence: winning friends and deflecting aggression. *Journal of Research in Personality*, 36(3), 224–251. <https://doi.org/10.1006/jrpe.2002.2348>
- John, O. P., Caspi, A., Robins, R. W., Moffitt, T. E., & Stouthamer-loeber, M. (1994). The “Little Five”: Exploring the nomological network of the Five-Factor model of personality in adolescent boys. *Child Development*, 65(1), 160–178. <https://doi.org/10.1111/j.1467-8624.1994.tb00742.x>
- John, O. P., Caspi, A., Robins, R. W., Moffitt, T. E., & Stouthamer-Loeber, M. (1994). The “Little Five”: Exploring the nomological network of the Five-Factor model of personality in adolescent boys. *Child Development*, 65(1), 160–178. <https://doi.org/10.1111/j.1467-8624.1994.tb00742.x>
- Johnson-Frey, S. H., Newman-Norlund, R., & Grafton, S. T. (2005). A distributed left hemisphere network active during planning of everyday tool use skills. *Cerebral Cortex*, 15(6), 681–695. <https://doi.org/10.1093/cercor/bhh169>
- Johnston, A. M., Holden, P. C., & Santos, L. R. (2017). Exploring the evolutionary origins of overimitation: a comparison across domesticated and non-domesticated canids. *Developmental Science*, 20(4). <https://doi.org/10.1111/desc.12460>
- Jolles, J. W., Fleetwood-Wilson, A., Nakayama, S., Stumpe, M. C., Johnstone, R. A., & Manica, A. (2015). The role of social attraction and its link with boldness in the collective movements of three-spined sticklebacks. *Animal Behaviour*, 99, 147–153. <https://doi.org/10.1016/j.anbehav.2014.11.004>
- Jones, T. B., Aplin, L. M., Devost, I., & Morand-Ferron, J. (2017). Individual and ecological determinants of social information transmission in the wild. *Animal Behaviour*, 129. <https://doi.org/10.1016/j.anbehav.2017.05.011>
- Kaufman, A. B., & Kaufman, J. C. (2015). *Animal Creativity and Innovation*. Animal Creativity and Innovation. Elsevier. <https://doi.org/10.1016/C2013-0-18605-9>
- Keiser, C. N., Pinter-Wollman, N., Augustine, D. A., Ziemba, M. J., Hao, L., Lawrence, J. G., & Pruitt, J. N. (2016). Individual differences in boldness influence patterns of social interactions and the transmission of cuticular bacteria among group-mates. *Proceedings of the Royal Society B: Biological Sciences*, 283(1829). <https://doi.org/10.1098/rspb.2016.0457>
- Kelemen, D., Seston, R., & Saint Georges, L. (2012). The designing mind: Children’s reasoning about intended function and artifact structure. *Journal of Cognition and Development*, 13(4), 439–453.

<https://doi.org/10.1080/15248372.2011.608200>

- Kempe, M., & Mesoudi, A. (2014). Experimental and theoretical models of human cultural evolution. *Wiley Interdisciplinary Reviews: Cognitive Science*. <https://doi.org/10.1002/wcs.1288>
- Kendal, J., Giraldeau, L.-A., & Laland, K. (2009). The evolution of social learning rules: payoff-biased and frequency-dependent biased transmission. *Journal of Theoretical Biology*, 260(2), 210–219. <https://doi.org/10.1016/j.jtbi.2009.05.029>
- Kendal, R. L., Coolen, I., & Laland, K. N. (2009). Adaptive trade-offs in the use of social and personal information. In *Cognitive Ecology II* (pp. 249–271). University of Chicago Press. <https://doi.org/10.7208/chicago/9780226169378.003.0013>
- Kendal, R. L., Custance, D. M., Kendal, J., Vale, G., Stoinski, T. S., Rakotomalala, N. L., & Rasamimanana, H. (2010). Evidence for social learning in wild lemurs (*Lemur catta*). *Learning & Behavior*, 38(3). <https://doi.org/10.3758/lb.38.3.220>
- Kendal, R. L., Hopper, L. M., Whiten, A., Brosnan, S. F., Lambeth, S. P., Schapiro, S. J., & Hoppitt, W. (2015). Chimpanzees copy dominant and knowledgeable individuals: implications for cultural diversity. *Evolution and Human Behavior*, 36(1), 65–72. <https://doi.org/10.1016/j.evolhumbehav.2014.09.002>
- Keupp, S., Behne, T., Zachow, J., Kasbohm, A., & Rakoczy, H. (2015). Over-imitation is not automatic: Context sensitivity in children's overimitation and action interpretation of causally irrelevant actions. *Journal of Experimental Child Psychology*, 130. <https://doi.org/10.1016/j.jecp.2014.10.005>
- King, J. E., & Figueredo, A. J. (1997). The five-factor model plus dominance in chimpanzee personality. *Journal of Research in Personality*, 31(2), 257–271. <https://doi.org/10.1006/jrpe.1997.2179>
- King, J. E., Weiss, A., & Sisco, M. M. (2008). Aping humans: Age and sex effects in chimpanzee (*Pan troglodytes*) and human (*Homo sapiens*) personality. *Journal of Comparative Psychology*, 122(4), 418–427. <https://doi.org/10.1037/a0013125>
- Klein, K. J., Saltz, J. L., & Mayer, D. M. (2004). How do they get there? An examination of the antecedents of centrality in team network. *Academy of Management Journal*, 47(6), 952–963. <https://doi.org/10.2307/20159634>
- Koo, T. K., & Li, M. Y. (2016). A Guideline of Selecting and Reporting Intraclass Correlation Coefficients for

Reliability Research. *Journal of Chiropractic Medicine*, 15(2), 155–163.
<https://doi.org/10.1016/j.jcm.2016.02.012>

Koops, K., Visalberghi, E., & van Schaik, C. P. (2014). The ecology of primate material culture. *Biology Letters*, 10(11), 20140508. <https://doi.org/10.1098/rsbl.2014.0508>

Koski, S. E. (2011). Social personality traits in chimpanzees: Temporal stability and structure of behaviourally assessed personality traits in three captive populations. *Behavioral Ecology and Sociobiology*, 65(11), 2161–2174. <https://doi.org/10.1007/s00265-011-1224-0>

Kratzer, J., & Lettl, C. (2008). A social network perspective of lead users and creativity: An empirical study among children. *Creativity and Innovation Management*, 17(1), 26–36. <https://doi.org/10.1111/j.1467-8691.2008.00466.x>

Kratzer, J., Lettl, C., Franke, N., & Gloor, P. A. (2016). The social network position of lead users. *Journal of Product Innovation Management*, 33(2), 201–216. <https://doi.org/10.1111/jpim.12291>

Krause, J., James, R., Franks, D. W., & Croft, D. P. (2015). *Animal social networks*. Oxford, UK: Oxford University Press.

Kremer, M., & Miguel, E. (2003). *Networks, social learning, and technology adoption: The case of deworming drugs in Kenya*. Center for Labor Economics, University of California, Berkeley.

Kuhar, C. W., Stoinski, T. S., Lukas, K. E., & Maple, T. L. (2006). Gorilla Behavior Index revisited: Age, housing and behavior. *Applied Animal Behaviour Science*, 96(3), 315–326.
<https://doi.org/10.1016/j.applanim.2005.06.004>

Kulahci, I. G., Rubenstein, D. I., Bugnyar, T., Hoppitt, W., Mikus, N., & Schwab, C. (2016). Social networks predict selective observation and information spread in ravens. *Royal Society Open Science*, 3(7), 160256.
<https://doi.org/10.1098/rsos.160256>

Kummer, H., & Goodall, J. (1985). Conditions of innovative behaviour in primates. *Philosophical Transactions of the Royal Society B: Biological Sciences*, 308(1135), 203–214. <https://doi.org/10.1098/rstb.1985.0020>

Kurvers, R. H. J. M., Prins, H. H. T., van Wieren, S. E., van Oers, K., Nolet, B. a, & Ydenberg, R. C. (2010). The effect of personality on social foraging: shy barnacle geese scrounge more. *Proceedings. Biological Sciences / The Royal Society*, 277(1681), 601–608. <https://doi.org/10.1098/rspb.2009.1474>

- Kurvers, R. H. J. M., van Oers, K., Nolet, B. a., Jonker, R. M., van Wieren, S. E., Prins, H. H. T., & Ydenberg, R. C. (2010). Personality predicts the use of social information. *Ecology Letters*, *13*, 829–837. <https://doi.org/10.1111/j.1461-0248.2010.01473.x>
- Ladd, G. W., & Kochenderfer, B. J. (1996). Linkages between friendship and adjustment during early school transitions. In *The company they keep: Friendship in childhood and adolescence* (pp. 322–345). New York: Cambridge University Press.
- Laland, K. N. (2004). Social learning strategies. *Animal Learning & Behavior*, *32*(1), 4–14. <https://doi.org/10.3758/BF03196002>
- Laland, K. N., & Galef, B. G. (2009). *The Question of Animal Culture*. Harvard University Press.
- Laland, K. N., & Janik, V. M. (2006). The animal cultures debate. *Trends in Ecology & Evolution*, *21*(10), 542–547. <https://doi.org/10.1016/j.tree.2006.06.005>
- Lamon, N., Neumann, C., Gruber, T., & Zuberbühler, K. (2017). Kin-based cultural transmission of tool use in wild chimpanzees. *Science Advances*, *3*(4). <https://doi.org/DOI:10.1126/sciadv.1602750>
- Latzman, R. D., Hecht, L. K., Freeman, H. D., Schapiro, S. J., & Hopkins, W. D. (2015). Neuroanatomical correlates of personality in chimpanzees (Pan troglodytes): Associations between personality and frontal cortex. *NeuroImage*, *123*, 63–71. <https://doi.org/10.1016/j.neuroimage.2015.08.041>
- Lau, S., Li, C. S., & Chu, D. (2004). Perceived creativity: its relationship to social status and self-concept among chinese high ability children. *Creativity Research Journal*, *16*(1), 59–67. https://doi.org/10.1207/s15326934crj1601_6
- Lau, S., & Li, W.-L. (1996). Peer status and perceived creativity: are popular children viewed by peers and teachers as creative. *Creativity Research Journal*, *9*(4), 347–352. https://doi.org/10.1207/s15326934crj0904_6
- Laursen, K., & Salter, A. (2006). Open for innovation: the role of openness in explaining innovation performance among U.K. manufacturing firms. *Strategic Management Journal*, *27*(2), 131–150. <https://doi.org/10.1002/smj.507>
- Leavens, D. A., Bard, K. A., & Hopkins, W. D. (2010). BIZARRE chimpanzees do not represent “the chimpanzee.” *Behavioral and Brain Sciences*, *33*(2–3), 100–101. <https://doi.org/10.1017/S0140525X10000166>
- Leavens, D. A., Bard, K. A., & Hopkins, W. D. (2017). The mismeasure of ape social cognition. *Animal Cognition*, *280*

1–18. <https://doi.org/10.1007/s10071-017-1119-1>

- Lee, S., & Klein, H. J. (2002). Relationships between conscientiousness, self-efficacy, self-deception, and learning over time. *The Journal of Applied Psychology, 87*(6), 1175–1182.
- Lefebvre, L., Whittle, P., Lascaris, E., & Finkelstein, A. (1997). Feeding innovations and forebrain size in birds. *Animal Behaviour, 53*(3), 549–560. <https://doi.org/10.1006/anbe.1996.0330>
- Legare, C. H. (2017). Cumulative cultural learning: Development and diversity. *Proceedings of the National Academy of Sciences, 114*(30). <https://doi.org/10.1073/pnas.1620743114>
- Legare, C. H., & Nielsen, M. (2015). Imitation and innovation: The dual engines of cultural learning. *Trends in Cognitive Sciences, 19*(11), 688–699. <https://doi.org/10.1016/j.tics.2015.08.005>
- Lepine, J. A., Colquitt, J. A., & Erez, A. (2000). Adaptability to changing task contexts: effects of general cognitive ability, conscientiousness, and openness to experience. *Personnel Psychology, 53*(3), 563–593. <https://doi.org/10.1111/j.1744-6570.2000.tb00214.x>
- Lermite, F., Peneaux, C., & Griffin, A. S. (2016). Personality and problem-solving in common mynas (*Acridotheres tristis*). *Behavioural Processes, 134*, 87–94. <https://doi.org/10.1016/j.beproc.2016.09.013>
- Li, W. L., Poon, J. C. Y., Tong, T. M. Y., & Lau, S. (2013). Psychological adjustment of creative children: perspectives from self, peer and teacher. *Educational Psychology, 33*(5), 616–627. <https://doi.org/10.1080/01443410.2013.824069>
- Liebal, K., Müller, C., & Pika, S. (2007). *Gestural communication in nonhuman and human primates*. Amsterdam: John Benjamins Publishing Company.
- Lindeyer, C. M., Meaney, M. J., & Reader, S. M. (2013). Early maternal care predicts reliance on social learning about food in adult rats. *Developmental Psychobiology, 55*(2), 168–175. <https://doi.org/10.1002/dev.21009>
- Lonsdorf, E. V. (2017). Sex differences in nonhuman primate behavioral development. *Journal of Neuroscience Research, 95*(1–2), 213–221. <https://doi.org/10.1002/jnr.23862>
- Lonsdorf, E. V., Eberly, L. E., & Pusey, A. E. (2004). Sex differences in learning in chimpanzees. *Nature, 428*(6984), 715–716. <https://doi.org/10.1038/428715a>
- Lorr, M., & Block, J. (1964). The Q-sort method in personality assessment and psychiatric research. *The American Journal of Psychology, 77*(1), 172. <https://doi.org/10.2307/1419315>

- Luan, Z., Hutteman, R., Denissen, J. J. A., Asendorpf, J. B., & van Aken, M. (2016). Do you see my growth? Two longitudinal studies on personality development from childhood to young adulthood from multiple perspectives. *Journal of Research in Personality*. <https://doi.org/10.1016/j.jrp.2016.03.004>
- Luncz, L. V., & Boesch, C. (2014). Tradition over trend: Neighboring chimpanzee communities maintain differences in cultural behavior despite frequent immigration of adult females. *American Journal of Primatology*, *76*(7), 649–657. <https://doi.org/10.1002/ajp.22259>
- Luncz, L. V., Mundry, R., & Boesch, C. (2012). Evidence for cultural differences between neighboring chimpanzee communities. *Current Biology*, *22*, 922–926. <https://doi.org/10.1016/j.cub.2012.03.031>
- Luncz, L. V., Wittig, R. M., & Boesch, C. (2015). Primate archaeology reveals cultural transmission in wild chimpanzees (*Pan troglodytes verus*). *Philosophical Transactions of the Royal Society of London. Series B, Biological Sciences*, *370*(1682). <https://doi.org/10.1098/rstb.2014.0348>
- Lyons, D. E., Young, A. G., & Keil, F. C. (2007). The hidden structure of overimitation. *Proceedings of the National Academy of Sciences of the United States of America*, *104*(50), 19751–19756. <https://doi.org/10.1073/pnas.0704452104>
- Mann, J., Stanton, M. A., Patterson, E. M., Bienenstock, E. J., & Singh, L. O. (2012). Social networks reveal cultural behaviour in tool-using dolphins. *Nature Communications*, *3*, 980. <https://doi.org/10.1038/ncomms1983>
- Manrique, H. M., & Call, J. (2011). Spontaneous use of tools as straws in great apes. *Animal Cognition*, *14*(2), 213–226. <https://doi.org/10.1007/s10071-010-0355-4>
- Manrique, H. M., Völter, C. J., & Call, J. (2013). Repeated innovation in great apes. *Animal Behaviour*, *85*(1), 195–202. <https://doi.org/10.1016/j.anbehav.2012.10.026>
- Manson, J. H., & Perry, S. (2013). Personality structure, sex differences, and temporal change and stability in wild white-faced capuchins (*Cebus capucinus*). *Journal of Comparative Psychology*, *127*(3), 299–311. <https://doi.org/10.1037/a0031316>
- Marchetti, C., & Drent, P. J. (2000). Individual differences in the use of social information in foraging by captive great tits. *Animal Behaviour*, *60*(1), 131–140. <https://doi.org/10.1006/anbe.2000.1443>
- Markey, P. M., Markey, C. N., & Tinsley, B. J. (2004). Children's behavioral manifestations of the Five-Factor model of personality. *Personality and Social Psychology Bulletin*, *30*(4), 423–432.

<https://doi.org/10.1177/0146167203261886>

- Markham, A. C., Lonsdorf, E. V., Pusey, A. E., & Murray, C. M. (2015). Maternal rank influences the outcome of aggressive interactions between immature chimpanzees. *Animal Behaviour*, *100*, 192–198. <https://doi.org/10.1016/j.anbehav.2014.12.003>
- Marlett, N. J., & Watson, D. (1968). Test anxiety and immediate or delayed feedback in a test-like avoidance task. *Journal of Personality and Social Psychology*, *8*(2, Pt.1), 200–203. <https://doi.org/10.1037/h0025273>
- Marshall-Pescini, S., & Whiten, A. (2008). Chimpanzees (*Pan troglodytes*) and the question of cumulative culture: An experimental approach. *Animal Cognition*, *11*(3), 449–456. <https://doi.org/10.1007/s10071-007-0135-y>
- Massen, J. J. M., Antonides, A., Arnold, A.-M. K., Bionda, T., & Koski, S. E. (2013). A behavioral view on chimpanzee personality: exploration tendency, persistence, boldness, and tool-orientation measured with group experiments. *American Journal of Primatology*, *75*(9), 947–958. <https://doi.org/10.1002/ajp.22159>
- Massen, J. J. M., & Koski, S. E. (2014). Chimps of a feather sit together: chimpanzee friendships are based on homophily in personality. *Evolution and Human Behavior*, *35*(1), 1–8. <https://doi.org/10.1016/j.evolhumbehav.2013.08.008>
- Matsuzawa, T., Biro, D., Humle, T., Inoue-Nakamura, N., Tonooka, R., & Yamakoshi, G. (2008). Emergence of culture in wild chimpanzees: education by master-apprenticeship. In *Primate Origins of Human Cognition and Behavior* (pp. 557–574). Tokyo: Springer Japan. https://doi.org/10.1007/978-4-431-09423-4_28
- McCowan, L. S. C., Rollins, L. A., & Griffith, S. C. (2014). Personality in captivity: more exploratory males reproduce better in an aviary population. *Behavioural Processes*, *107*, 150–157. <https://doi.org/10.1016/j.beproc.2014.08.020>
- McCrae, R. R. (1987). Creativity, divergent thinking, and openness to experience. *Journal of Personality and Social Psychology*, *52*(6), 1258–1265. <https://doi.org/10.1037//0022-3514.52.6.1258>
- McCrae, R. R., & John, O. P. (1992). An introduction to the five-factor model and its applications. *Journal of Personality*, *60*(2), 175–215. <https://doi.org/10.1111/j.1467-6494.1992.tb00970.x>
- McDonald, J. (2009). *Handbook of Biological Statistics*. Sparky House Publishing.
- McGuigan, N., Burdett, E., Burgess, V., Dean, L. G., Lucas, A., Vale, G., & Whiten, A. (2017). Innovation and social transmission in experimental micro-societies: exploring the scope of cumulative culture in young

children. *Philosophical Transactions of the Royal Society of London. Series B, Biological Sciences*, 372(1735), 20160425. <https://doi.org/10.1098/rstb.2016.0425>

McGuigan, N., Makinson, J., & Whiten, A. (2011). From over-imitation to super-copying: Adults imitate causally irrelevant aspects of tool use with higher fidelity than young children. *British Journal of Psychology*, 102(1), 1–18. <https://doi.org/10.1348/000712610X493115>

McGuigan, N., & Robertson, S. (2015). The influence of peers on the tendency of 3- and 4-year-old children to over-imitate. *Journal of Experimental Child Psychology*, 136. <https://doi.org/10.1016/j.jecp.2015.03.004>

McGuigan, N., Whiten, A., Flynn, E. G., & Horner, V. (2007). Imitation of causally opaque versus causally transparent tool use by 3- and 5-year-old children. *Cognitive Development*, 22(3), 353–364. <https://doi.org/10.1016/j.cogdev.2007.01.001>

McPherson, M., Smith-Lovin, L., & Cook, J. M. (2001). Birds of a feather: Homophily in social networks. *Annual Review of Sociology*, 27(1), 415–444. <https://doi.org/10.1146/annurev.soc.27.1.415>

Mednick, S. C., Christakis, N. A., & Fowler, J. H. (2010). The spread of sleep loss influences drug use in adolescent social networks. *PloS One*, 5(3), e9775. <https://doi.org/10.1371/journal.pone.0009775>

Melo, A. I., Lovic, V., Gonzalez, A., Madden, M., Sinopoli, K., & Fleming, A. S. (2006). Maternal and littermate deprivation disrupts maternal behavior and social-learning of food preference in adulthood: tactile stimulation, nest odor, and social rearing prevent these effects. *Developmental Psychobiology*, 48(3), 209–219. <https://doi.org/10.1002/dev.20130>

Meltzoff, A. N., & Moore, M. K. (1989). Imitation in newborn infants: Exploring the range of gestures imitated and the underlying mechanisms. *Developmental Psychology*, 25(6), 954–962. <https://doi.org/10.1037/0012-1649.25.6.954>

Mesoudi, A. (2011). An experimental comparison of human social learning strategies: payoff-biased social learning is adaptive but underused. *Evolution and Human Behavior*, 32(5), 334–342. <https://doi.org/10.1016/j.evolhumbehav.2010.12.001>

Mesoudi, A. (2017). Pursuing Darwin's curious parallel: Prospects for a science of cultural evolution. *Proceedings of the National Academy of Sciences*, 114(30), 7853–7860. <https://doi.org/10.1073/pnas.1620741114>

Mesoudi, A., Chang, L., Dall, S. R. ., & Thornton, A. (2016). The evolution of individual and cultural variation in

- social learning. *Trends in Ecology & Evolution*, 31(3), 215–225. <https://doi.org/10.1016/j.tree.2015.12.012>
- Mesoudi, A., Chang, L., Murray, K., & Lu, H. J. (2014). Higher frequency of social learning in China than in the West shows cultural variation in the dynamics of cultural evolution. *Proceedings of the Royal Society B: Biological Sciences*, 282(1798), 20142209–20142209. <https://doi.org/10.1098/rspb.2014.2209>
- Messer, S. (1970). The effect of anxiety over intellectual performance on reflection-impulsivity in children. *Child Development*, 41(3), 723. <https://doi.org/10.2307/1127219>
- Michelena, P., Jeanson, R., Deneubourg, J.-L., & Sibbald, A. M. (2010). Personality and collective decision-making in foraging herbivores. *Proceedings of the Royal Society B: Biological Sciences*, 277(1684), 1093–1099. <https://doi.org/10.1098/rspb.2009.1926>
- Molleman, L., van den Berg, P., & Weissing, F. J. (2014). Consistent individual differences in human social learning strategies. *Nature Communications*, 5, 3570. <https://doi.org/10.1038/ncomms4570>
- Mooradian, T., Renzl, B., & Matzler, K. (2006). Who Trusts? Personality, trust and knowledge sharing. *Management Learning*, 37(4), 523–540. <https://doi.org/10.1177/1350507606073424>
- Morand-Ferron, J., Cole, E. F., Rawles, J. E. C., & Quinn, J. L. (2011). Who are the innovators? A field experiment with 2 passerine species. *Behavioral Ecology*, 22(6), 1241–1248. <https://doi.org/10.1093/beheco/arr120>
- Morgan, T. J. H., Laland, K. N., & Harris, P. L. (2014). The development of adaptive conformity in young children: effects of uncertainty and consensus. *Developmental Science*, 18(4), 1–14. <https://doi.org/10.1111/desc.12231>
- Morgan, T. J. H., Rendell, L. E., Ehn, M., Hoppitt, W., & Laland, K. N. (2012). The evolutionary basis of human social learning. *Proceedings of the Royal Society B: Biological Sciences*, 279(1729), 653–662. <https://doi.org/10.1098/rspb.2011.1172>
- Morton, F. B., Lee, P. C., & Buchanan-Smith, H. M. (2013). Taking personality selection bias seriously in animal cognition research: A case study in capuchin monkeys (*Sapajus apella*). *Animal Cognition*, 16(4), 677–684. <https://doi.org/10.1007/s10071-013-0603-5>
- Moultapa, M., Valente, T., Gallaher, P., Rohrbach, L. A., & Unger, J. B. (2004). Social network predictors of bullying and victimization. *Adolescence*, 39(154), 315–335. Retrieved from <http://www.ncbi.nlm.nih.gov/pubmed/15563041>
- Mukaka, M. M. (2012). Statistics corner: A guide to appropriate use of correlation coefficient in medical research.

- Malawi Medical Journal: The Journal of Medical Association of Malawi*, 24(3), 69–71. Retrieved from <http://www.ncbi.nlm.nih.gov/pubmed/23638278>
- Muthukrishna, M., & Henrich, J. (2016). Innovation in the collective brain. *Philosophical Transactions of the Royal Society B: Biological Sciences*, 371(1690), 20150192. <https://doi.org/10.1098/rstb.2015.0192>
- Muthukrishna, M., Morgan, T. J. H., & Henrich, J. (2015). The when and who of social learning and conformist transmission. *Evolution and Human Behavior*, 37(1), 10–20. <https://doi.org/10.1016/j.evolhumbehav.2015.05.004>
- Nagell, K., Olguin, R. S., & Tomasello, M. (1993). Processes of social learning in the tool use of chimpanzees (*Pan troglodytes*) and human children (*Homo sapiens*). *Journal of Comparative Psychology*, 107(2), 174–186.
- Navarrete, A. F., Reader, S. M., Street, S. E., Whalen, A., & Laland, K. N. (2016). The coevolution of innovation and technical intelligence in primates. *Philosophical Transactions of the Royal Society B: Biological Sciences*, 371(1690), 20150186. <https://doi.org/10.1098/rstb.2015.0186>
- Nawroth, C., Prentice, P. M., & McElligott, A. G. (2016). Individual personality differences in goats predict their performance in visual learning and non-associative cognitive tasks. *Behavioural Processes*. <https://doi.org/10.1016/j.beproc.2016.08.001>
- Neal, J. W. (2011). “Kracking” the missing data problem: applying Krackhardt’s cognitive social structures to school-based social networks. *Sociology The Journal Of The British Sociological Association*, 81(2), 140–162.
- Neal, J. W., & Neal, Z. P. (2013). The multiple meanings of peer groups in social cognitive mapping. *Social Development*, 22(3), 580–594. <https://doi.org/10.1111/j.1467-9507.2012.00656.x>
- Neldner, K., Mushin, I., & Nielsen, M. (2017). Young children’s tool innovation across culture: Affordance visibility matters. *Cognition*, 168, 335–343. <https://doi.org/10.1016/j.cognition.2017.07.015>
- Nettle, D. (2006). The evolution of personality variation in humans and other animals. *The American Psychologist*, 61(6), 622–631. <https://doi.org/10.1037/0003-066X.61.6.622>
- Nettle, D. (2007). *Personality: What makes you the way you are*. OUP Oxford.
- Newcomb, A. F., Bukowski, W. M., & Pattee, L. (1993). Children’s peer relations: a meta-analytic review of popular, rejected, neglected, controversial, and average sociometric status. *Psychological Bulletin*, 113(1),

- Nielsen, M. (2013). Young children's imitative and innovative behaviour on the floating object task. *Infant and Child Development*, 22(1), 44–52. <https://doi.org/10.1002/icd.1765>
- Nielsen, M., Cucchiaro, J., & Mohamedally, J. (2012). When the transmission of culture is child's play. *PloS One*, 7(3), e34066. <https://doi.org/10.1371/journal.pone.0034066>
- Nielsen, M., & Haun, D. (2016). Why developmental psychology is incomplete without comparative and cross-cultural perspectives. *Philosophical Transactions of the Royal Society of London. Series B, Biological Sciences*, 371(1686), 20150071. <https://doi.org/10.1098/rstb.2015.0071>
- Nielsen, M., Haun, D., Kärtner, J., & Legare, C. H. (2017). The persistent sampling bias in developmental psychology: A call to action. *Journal of Experimental Child Psychology*, 162. <https://doi.org/10.1016/j.jecp.2017.04.017>
- Nielsen, M., Mushin, I., Tomaselli, K., & Whiten, A. Where culture takes hold: “overimitation” and its flexible deployment in Western, Aboriginal, and Bushmen children. *Child Development*, 85(6), 2169–2184. <https://doi.org/10.1111/cdev.12265>
- Nielsen, M., Mushin, I., Tomaselli, K., & Whiten, A. (2016). Imitation, collaboration and their interaction among Western and Indigenous Australian preschool children. *Child Development*, 87(3), 795–806. <https://doi.org/10.1111/cdev.12504>
- Nielsen, M., & Tomaselli, K. (2010). Overimitation in Kalahari Bushman children and the origins of human cultural cognition. *Psychological Science*, 21(5), 729–736. <https://doi.org/10.1177/0956797610368808>
- Nielsen, M., Tomaselli, K., Mushin, I., & Whiten, A. (2014). Exploring tool innovation: a comparison of Western and Bushman children. *Journal of Experimental Child Psychology*, 126, 384–394. <https://doi.org/10.1016/j.jecp.2014.05.008>
- Nishida, T., Matsusaka, T., & McGrew, W. C. (2009). Emergence, propagation or disappearance of novel behavioral patterns in the habituated chimpanzees of Mahale: a review. *Primates; Journal of Primatology*, 50(1), 23–36. <https://doi.org/10.1007/s10329-008-0109-y>
- Nogueira, S., Sechidis, K., & Brown, G. (2017). On the use of Spearman's Rho to measure the stability of feature rankings. In *Lecture Notes in Computer Science book series (LNCS, volume 10255)* (Vol. 10255 LNCS, pp. 287

381–391). Springer, Cham. https://doi.org/10.1007/978-3-319-58838-4_42

- Nomakuchi, S., Park, P. J., & Bell, M. A. (2009). Correlation between exploration activity and use of social information in three-spined sticklebacks. *Behavioral Ecology*, 20(2), 340–345. <https://doi.org/10.1093/beheco/arp001>
- Norton, G. R., Cox, B. J., Hewitt, P. L., & McLeod, L. (1997). Personality factors associated with generalized and non-generalized social anxiety. *Personality and Individual Differences*, 22(5), 655–660. [https://doi.org/10.1016/S0191-8869\(96\)00243-7](https://doi.org/10.1016/S0191-8869(96)00243-7)
- O'Brien, M. J., & Shennan, S. (2010). *Innovation in cultural systems: contributions from evolutionary anthropology*. MIT Press.
- Over, H., & Carpenter, M. (2012). Putting the social into social learning: explaining both selectivity and fidelity in children's copying behavior. *Journal of Comparative Psychology*, 126(2), 182–192. <https://doi.org/10.1037/a0024555>
- Over, H., & Carpenter, M. (2013). The social side of imitation. *Child Development Perspectives*, 7(1), 6–11. <https://doi.org/10.1111/cdep.12006>
- Overington, S. E., Cauchard, L., Côté, K. A., & Lefebvre, L. (2011). Innovative foraging behaviour in birds: What characterizes an innovator? *Behavioural Processes*, 87(3), 274–285. <https://doi.org/10.1016/j.beproc.2011.06.002>
- Pellegrini, A. D., Dupuis, D., & Smith, P. K. (2007). Play in evolution and development. *Developmental Review*, 27(2), 261–276. <https://doi.org/10.1016/J.DR.2006.09.001>
- Pellegrini, A. D., & Smith, P. K. (2005). *The Nature of Play: Great Apes and Humans*. Guilford Press.
- Pettigrew, F. (2002). *Summing up: Relative deprivation as a key social psychological concept*. (I. Walker & H. J. Smith, Eds.). New York, NY: Cambridge University Press.
- Piedmont, R. L. (1998). Psychometric Overview of the NEO PI-R. In *The Revised NEO Personality Inventory* (pp. 35–77). Boston, MA: Springer US. https://doi.org/10.1007/978-1-4899-3588-5_2
- Pike, N. (2011). Using false discovery rates for multiple comparisons in ecology and evolution. *Methods in Ecology and Evolution*, 2(3), 278–282. <https://doi.org/10.1111/j.2041-210X.2010.00061.x>
- Pike, T. W., Samanta, M., Lindström, J., & Royle, N. J. (2008). Behavioural phenotype affects social interactions

in an animal network. *Proceedings. Biological Sciences*, 275(1650), 2515–2520.
<https://doi.org/10.1098/rspb.2008.0744>

Pollet, T. V., Roberts, S. G. B., & Dunbar, R. I. M. (2011). Extraverts have larger social network layers. *Journal of Individual Differences*, 32(3), 161–169. <https://doi.org/10.1027/1614-0001/a000048>

Poropat, A. E. (2009). A meta-analysis of the five-factor model of personality and academic performance. *Psychological Bulletin*, 135(2), 322–338. <https://doi.org/10.1037/a0014996>

Poropat, A. E. (2014a). A meta-analysis of adult-rated child personality and academic performance in primary education. *British Journal of Educational Psychology*, 84(2), 239–252. <https://doi.org/10.1111/bjep.12019>

Poropat, A. E. (2014b). Other-rated personality and academic performance: Evidence and implications. *Learning and Individual Differences*, 34, 24–32. <https://doi.org/10.1016/j.lindif.2014.05.013>

Poss, S. R., & Rochat, P. (2003). Referential understanding of videos in chimpanzees (*Pan troglodytes*), orangutans (*Pongo pygmaeus*), and children (*Homo sapiens*). *Journal of Comparative Psychology*, 117(4), 420–428. <https://doi.org/10.1037/0735-7036.117.4.420>

Poulin, F., & Dishion, T. J. (2008). Methodological issues in the use of peer sociometric nominations with middle school youth. *Social Development*, 17(4), 908–921. <https://doi.org/10.1111/j.1467-9507.2008.00473.x>

Price, E., & Caldwell, C. A. (2007). Artificially generated cultural variation between two groups of captive monkeys, *Colobus guereza kikuyuensis*. *Behavioural Processes*, 74(1), 13–20. <https://doi.org/10.1016/j.beproc.2006.09.003>

Price, E., Lambeth, S. P., Schapiro, S. J., & Whiten, A. (2009). A potent effect of observational learning on chimpanzee tool construction. *Proceedings. Biological Sciences / The Royal Society*, 276(1671), 3377–3383. <https://doi.org/10.1098/rspb.2009.0640>

Price, E., Wood, L. A., & Whiten, A. (2017). Adaptive cultural transmission biases in children and nonhuman primates. *Infant Behavior and Development*, 48, 45–53. <https://doi.org/10.1016/j.infbeh.2016.11.003>

Rawlings, B., Davila-Ross, M., & Boysen, S. T. (2014). Semi-wild chimpanzees open hard-shelled fruits differently across communities. *Animal Cognition*, 17(4), 891–899. <https://doi.org/10.1007/s10071-013-0722-z>

Rawlings, B., Flynn, E., & Kendal, R. L. (2017). To copy or to innovate? The role of personality and social networks in children's learning strategies. *Child Development Perspectives*, 11(1), 39–44.

<https://doi.org/10.1111/cdep.12206>

- Reader, S. M. (2015). Causes of Individual Differences in Animal Exploration and Search. *Topics in Cognitive Science*, 7(3). <https://doi.org/10.1111/tops.12148>
- Reader, S. M., & Laland, K. N. (2001). Primate innovation: Sex, age and social rank differences. *International Journal of Primatology*, 22(5), 787–805. <https://doi.org/10.1023/A:1012069500899>.
- Reader, S. M., & Laland, K. N. (2003). *Animal Innovation*. Oxford University Press.
- Reader, S. M., Morand-Ferron, J., & Flynn, E. (2016). Animal and human innovation: novel problems and novel solutions. *Philosophical Transactions of the Royal Society B: Biological Sciences*, 371(1690), 20150182. <https://doi.org/10.1098/rstb.2015.0182>
- Réale, D., Reader, S. M., Sol, D., McDougall, P. T., & Dingemanse, N. J. (2007). Integrating animal temperament within ecology and evolution. *Biological Reviews of the Cambridge Philosophical Society*, 82(2), 291–318. <https://doi.org/10.1111/j.1469-185X.2007.00010.x>
- Reindl, E., Apperly, I. A., Beck, S. R., & Tennie, C. (2017). Young children copy cumulative technological design in the absence of action information. *Scientific Reports*, 7(1). <https://doi.org/10.1038/s41598-017-01715-2>
- Rendell, L., Boyd, R., Cownden, D., Enquist, M., Eriksson, K., Feldman, M. W., ... Laland, K. N. (2010). Why copy others? Insights from the social learning strategies tournament. *Science*, 328(5975), 208–213. <https://doi.org/10.1126/science.1184719>
- Rendell, L., Fogarty, L., Hoppitt, W., Morgan, T. J. H., Webster, M. M., & Laland, K. N. (2011). Cognitive culture: theoretical and empirical insights into social learning strategies. *Trends in Cognitive Sciences*, 15(2), 68–76. <https://doi.org/10.1016/j.tics.2010.12.002>
- Richerson, P. J., & Boyd, R. (2005). *Not by genes alone: how culture transformed human evolution*. University of Chicago Press.
- Rieucou, G., & Giraldeau, L.-A. (2011). Exploring the costs and benefits of social information use: an appraisal of current experimental evidence. *Philosophical Transactions of the Royal Society B: Biological Sciences*, 366(1567), 949–957. <https://doi.org/10.1098/rstb.2010.0325>
- Roberts, B. W., & DelVecchio, W. F. (2000). The rank-order consistency of personality traits from childhood to old age: A quantitative review of longitudinal studies. *Psychological Bulletin*, 126(1), 3–25.

<https://doi.org/10.1037/0033-2909.126.1.3>

- Roberts, B. W., Walton, K. E., & Viechtbauer, W. (2006). Patterns of mean-level change in personality traits across the life course: A meta-analysis of longitudinal studies. *Psychological Bulletin*, *132*(1), 1–25. <https://doi.org/10.1037/0033-2909.132.1.1>
- Roberts, S. G. B., Wilson, R., Fedurek, P., & Dunbar, R. I. M. (2008). Individual differences and personal social network size and structure. *Personality and Individual Differences*. <https://doi.org/10.1016/j.paid.2007.10.033>
- Rogers, A. R. (1988). Does biology constrain culture. *American Anthropologist*, *90*(4), 819–831. <https://doi.org/10.1525/aa.1988.90.4.02a00030>
- Roostaei, M., Mohammadi, R., & Amri, A. (2014). Rank correlation among different statistical models in ranking of winter wheat genotypes. *The Crop Journal*, *2*(2–3), 154–163. <https://doi.org/10.1016/J.CJ.2014.02.002>
- Rosa, P., Nguyen, V., & Dubois, F. (2012). Individual differences in sampling behaviour predict social information use in zebra finches. *Behavioral Ecology and Sociobiology*, *66*(9), 1259–1265. <https://doi.org/10.1007/s00265-012-1379-3>
- Rosenquist, J. N., Fowler, J. H., & Christakis, N. A. (2011). Social network determinants of depression. *Molecular Psychiatry*, *16*(3), 273–281. <https://doi.org/10.1038/mp.2010.13>
- Ross, C., Orr, E. S., Sisic, M., Arseneault, J. M., Simmering, M. G., & Orr, R. R. (2009). Personality and motivations associated with Facebook use. *Computers in Human Behavior*, *25*(2), 578–586. <https://doi.org/10.1016/J.CHB.2008.12.024>
- Runco, M. a. (1992). Children's divergent thinking and creative ideation. *Developmental Review*, *12*(3), 233–264. [https://doi.org/10.1016/0273-2297\(92\)90010-Y](https://doi.org/10.1016/0273-2297(92)90010-Y)
- Sanz, C., & Morgan, D. B. (2013). Ecological and social correlates of chimpanzee tool use. *Philosophical Transactions of the Royal Society of London B: Biological Sciences*, *368*(1630).
- Sapolsky, R. M., & Share, L. J. (2004). A Pacific culture among wild baboons: Its emergence and transmission. *PLoS Biology*, *2*(4), e106. <https://doi.org/10.1371/journal.pbio.0020106>
- Sauermann, H., & Cohen, W. M. (2010). What makes them tick? Employee motives and firm innovation. *Management Science*, *56*(12), 2134–2153. <https://doi.org/10.1287/mnsc.1100.1241>
- Schel, A. M., Rawlings, B., Claidière, N., Wilke, C., Wathan, J., Richardson, J., ... Slocombe, K. (2013). Network

- analysis of social changes in a captive chimpanzee community following the successful integration of two adult groups. *American Journal of Primatology*, 75(3), 254–266. <https://doi.org/10.1002/ajp.22101>
- Scher, S. J., & Osterman, N. M. (2002). Procrastination, conscientiousness, anxiety, and goals: Exploring the measurement and correlates of procrastination among school-aged children. *Psychology in the Schools*, 39(4), 385–398. <https://doi.org/10.1002/pits.10045>
- Schillaci, R. S., & Kelemen, D. (2014). Children’s conformity when acquiring novel conventions: The case of artifacts. *Journal of Cognition and Development*, 15(4), 569–583. <https://doi.org/10.1080/15248372.2013.784973>
- Schleihauf, H., Graetz, S., Pauen, S., & Hoehl, S. (2018). Contrasting Social and Cognitive Accounts on Overimitation: The Role of Causal Transparency and Prior Experiences. *Child Development*, 89(3), 1039–1055. <https://doi.org/10.1111/cdev.12780>
- Schmitt, D. P., Realo, A., Voracek, M., & Allik, J. (2008). Why can’t a man be more like a woman? Sex differences in Big Five personality traits across 55 cultures. *Journal of Personality and Social Psychology*, 94(1), 168–182. <https://doi.org/10.1037/0022-3514.94.1.168>
- Schneider, B. L., Ford, T., & Perez-Felkner, L. (2010). Social networks and the education of children and youth. *International Encyclopedia of Education*, (1973), 705–711. <https://doi.org/10.1016/B978-0-08-044894-7.00627-8>
- Scollon, C. N., & Diener, E. (2006). Love, work, and changes in extraversion and neuroticism over time. *Journal of Personality and Social Psychology*, 91(6), 1152–1165. <https://doi.org/10.1037/0022-3514.91.6.1152>
- Sibbald, A. M., Erhard, H. W., McLeod, J. E., & Hooper, R. J. (2009). Individual personality and the spatial distribution of groups of grazing animals: An example with sheep. *Behavioural Processes*, 82(3), 319–326. <https://doi.org/10.1016/j.beproc.2009.07.011>
- Sigg, H. (1980). Differentiation of female positions in hamadryas one-male-units. *Zeitschrift Für Tierpsychologie*, 53(3), 265–302. <https://doi.org/10.1111/j.1439-0310.1980.tb01054.x>
- Sih, A., Mathot, K. J., Moirón, M., Montiglio, P.-O., Wolf, M., & Dingemanse, N. J. (2014). Animal personality and state–behaviour feedbacks: a review and guide for empiricists. *Trends in Ecology & Evolution*, 30(1). <https://doi.org/10.1016/j.tree.2014.11.004>

- Silverman, I. W. (2003). Gender differences in delay of gratification: A meta-analysis. *Sex Roles, 49*(9/10), 451–463. <https://doi.org/10.1023/A:1025872421115>
- Silvia, P. J., Kaufman, J. C., Reiter-Palmon, R., & Wigert, B. (2011). *Cantankerous creativity: honesty–humility, agreeableness, and the HEXACO structure of creative achievement. Personality and Individual Differences* (Vol. 51). <https://doi.org/10.1016/j.paid.2011.06.011>
- Smith, B. R., & Blumstein, D. T. (2008). Fitness consequences of personality: A meta-analysis. *Behavioral Ecology, 19*(2), 448–455. <https://doi.org/10.1093/beheco/arm144>
- Smits, I. A. M., Dolan, C. V, Vorst, H. C. M., Wicherts, J. M., & Timmerman, M. E. (2011). Cohort differences in Big Five personality factors over a period of 25 years. *Journal of Personality and Social Psychology, 100*(6), 1124–1138. <https://doi.org/10.1037/a0022874>
- Sol, D., Duncan, R. P., Blackburn, T. M., Cassey, P., & Lefebvre, L. (2005). Big brains, enhanced cognition, and response of birds to novel environments. *Proceedings of the National Academy of Sciences of the United States of America, 102*(15), 5460–5465. <https://doi.org/10.1073/pnas.0408145102>
- Soto, C. J., & John, O. P. (2012). Development of Big Five domains and facets in adulthood: mean-level age trends and broadly versus narrowly acting mechanisms. *Journal of Personality, 80*(4), 881–914. <https://doi.org/10.1111/j.1467-6494.2011.00752.x>
- Spagnoletti, N., Visalberghi, E., Verderane, M. P., Ottoni, E., Izar, P., & Frigaszy, D. (2012). Stone tool use in wild bearded capuchin monkeys, *Cebus libidinosus*. Is it a strategy to overcome food scarcity? *Animal Behaviour, 83*(5), 1285–1294. <https://doi.org/10.1016/j.anbehav.2012.03.002>
- Srivastava, S., John, O. P., Gosling, S. D., & Potter, J. (2003). Development of personality in early and middle adulthood: set like plaster or persistent change? *Journal of Personality and Social Psychology, 84*(5), 1041–1053. <https://doi.org/10.1037/0022-3514.84.5.1041>
- Staes, N., Eens, M., Weiss, A., & Stevens, J. M. G. (2016). Bonobo personality: age and sex effects and links with behavior and dominance. *Bonobos: Unique in Mind, Brain and Behavior*.
- Storey, J. D. (2002). A direct approach to false discovery rates. *Journal of the Royal Statistical Society. Series B (Statistical Methodology)*. Wiley Royal Statistical Society. <https://doi.org/10.2307/3088784>
- Stöwe, M., Bugnyar, T., Heinrich, B., & Kotrschal, K. (2006). Effects of group size on approach to novel objects

- in ravens (*Corvus corax*). *Ethology*, *112*(11), 1079–1088. <https://doi.org/10.1111/j.1439-0310.2006.01273.x>
- Street, S. E., Navarrete, A. F., Reader, S. M., & Laland, K. N. (2017). Coevolution of cultural intelligence, extended life history, sociality, and brain size in primates. *Proceedings of the National Academy of Sciences*, *114*(30), 7908–7914. <https://doi.org/10.1073/pnas.1620734114>
- Tebbich, S., Griffin, A. S., Peschl, M. F., & Sterelny, K. (2016). From mechanisms to function: an integrated framework of animal innovation. *Philosophical Transactions of the Royal Society of London. Series B, Biological Sciences*, *371*(1690), 20150195-. <https://doi.org/10.1098/rstb.2015.0195>
- Templeton, J. J., & Giraldeau, L.-A. (1996). Vicarious sampling: the use of personal and public information by starlings foraging in a simple patchy environment. *Behavioral Ecology and Sociobiology*, *38*(2), 105–114. <https://doi.org/10.1007/s002650050223>
- Tennie, C., Call, J., & Tomasello, M. (2006). Push or pull: Imitation vs. emulation in great apes and human children. *Ethology*, *112*(12), 1159–1169. <https://doi.org/10.1111/j.1439-0310.2006.01269.x>
- Tennie, C., Call, J., & Tomasello, M. (2009). Ratcheting up the ratchet: on the evolution of cumulative culture. *Philosophical Transactions of the Royal Society of London. Series B, Biological Sciences*, *364*(1528), 2405–2415. <https://doi.org/10.1098/rstb.2009.0052>
- Toelch, U., Bruce, M. J., Newson, L., Richerson, P. J., & Reader, S. M. (2013). Individual consistency and flexibility in human social information use. *Proceedings of the Royal Society B: Biological Sciences*, *281*(1776), 20132864–20132864. <https://doi.org/10.1098/rspb.2013.2864>
- Tomasello, M., & Call, J. (2004). The role of humans in the cognitive development of apes revisited. *Animal Cognition*. <https://doi.org/10.1007/s10071-004-0227-x>
- Tomasello, M., Call, J., Warren, J., Frost, G. T., Carpenter, M., & Nagell, K. (1997). The ontogeny of chimpanzee gestural signals: A comparison across groups and generations. *Evolution of Communication*, *1*(2), 223–259. <https://doi.org/10.1075/eoc.1.2.04tom>
- Toyokawa, W., Saito, Y., & Kameda, T. (2017). Individual differences in learning behaviours in humans: Asocial exploration tendency does not predict reliance on social learning. *Evolution and Human Behavior*, *38*(3), 325–333. <https://doi.org/10.1016/j.evolhumbehav.2016.11.001>
- Trompf, L., & Brown, C. (2014). Personality affects learning and trade-offs between private and social information

- in guppies, *Poecilia reticulata*. *Animal Behaviour*, 88, 99–106. <https://doi.org/10.1016/j.anbehav.2013.11.022>
- Tucker-Drob, E. M. (2011). Individual differences methods for randomized experiments. *Psychological Methods*, 16(3), 298–318. <https://doi.org/10.1037/a0023349>
- Turner, C., & Flynn, E. (2016). Learning by diffusion: Using diffusion experiments and social network analysis to understand the dynamics of cultural evolution. In S. S. Obhi & E. S. Cross (Eds.), *Shared Representations* (pp. 503–524). Cambridge: Cambridge University Press. <https://doi.org/10.1017/CBO9781107279353.025>
- Úbeda, Y., & Llorente, M. (2015). Personality in sanctuary-housed chimpanzees: A comparative approach of psychobiological and penta-factorial human models. *Evolutionary Psychology*, 13(1), 147470491501300. <https://doi.org/10.1177/147470491501300111>
- Vale, G., Carr, K., Dean, L. G., & Kendal, R. L. (2017). The cultural capacity of human and nonhuman primates: social learning, innovation, and cumulative cultural evolution. In *Evolution of Nervous Systems* (2nd Edition, pp. 475–508). Elsevier. <https://doi.org/10.1016/B978-0-12-804042-3.00095-6>
- Vale, G., Davis, S. J., Lambeth, S. P., Schapiro, S. J., & Whiten, A. (2016). Acquisition of a socially learned tool use sequence in chimpanzees: Implications for cumulative culture. *Evolution and Human Behavior*. <https://doi.org/10.1016/j.evolhumbehav.2017.04.007>
- Vale, G., Davis, S. J., van de Waal, E., Schapiro, S. J., Lambeth, S. P., & Whiten, A. (2017). Lack of conformity to new local dietary preferences in migrating captive chimpanzees. *Animal Behaviour*, 124, 135–144. <https://doi.org/10.1016/j.anbehav.2016.12.007>
- Vale, G., Flynn, E. G., Kendal, J., Rawlings, B., Hopper, L. M., Schapiro, S. J., ... Kendal, R. L. (2017). Testing differential use of payoff-biased social learning strategies in children and chimpanzees. *Proceedings. Biological Sciences*, 284(1868), 20171751. <https://doi.org/10.1098/rspb.2017.1751>
- Vale, G., Flynn, E. G., Lambeth, S. P., Schapiro, S. J., & Kendal, R. L. (2014). Public information use in chimpanzees (*Pan troglodytes*) and children (*Homo sapiens*). *Journal of Comparative Psychology*, 128(2), 215–223. <https://doi.org/10.1037/a0034420>
- van Bergen, Y., Coolen, I., & Laland, K. (2004). Nine-spined sticklebacks exploit the most reliable source when public and private information conflict. *Proceedings. Biological Sciences / The Royal Society*, 271(1542), 957–962. <https://doi.org/10.1098/rspb.2004.2684>

- Van de Waal, E., Bshary, R., & Whiten, A. (2014). Wild vervet monkey infants acquire the food-processing variants of their mothers. *Animal Behaviour*, *90*. <https://doi.org/10.1016/j.anbehav.2014.01.015>
- van de Waal, E., Claidière, N., & Whiten, A. (2013). Social learning and spread of alternative means of opening an artificial fruit in four groups of vervet monkeys. *Animal Behaviour*, *85*(1), 71–76. <https://doi.org/10.1016/j.anbehav.2012.10.008>
- Van De Waal, E., Claidière, N., & Whiten, A. (2014). Wild vervet monkeys copy alternative methods for opening an artificial fruit. *Animal Cognition*. <https://doi.org/10.1007/s10071-014-0830-4>
- van Leeuwen, E. J. C., & Call, J. (2016). Conservatism and “copy-if-better” in chimpanzees (Pan troglodytes). *Animal Cognition*, *20*(3), 575–579. <https://doi.org/10.1007/s10071-016-1061-7>
- van Leeuwen, E. J. C., Call, J., & Haun, D. (2014). Human children rely more on social information than chimpanzees do. *Biology Letters*, *10*(11), 20140487. <https://doi.org/10.1098/rsbl.2014.0487>
- van Leeuwen, E. J. C., Cronin, K. A., & Haun, D. (2014). A group-specific arbitrary tradition in chimpanzees (Pan troglodytes). *Animal Cognition*, *17*(6), 1421–1425. <https://doi.org/10.1007/s10071-014-0766-8>
- van Leeuwen, E. J. C., Cronin, K., Haun, D. B. M., Mundry, R., & Bodamer, M. D. (2012). Neighbouring chimpanzee communities show different preferences in social grooming behaviour. *Proceedings of the Royal Society B: Biological Sciences*, *279*(1746), 4362–4367. <https://doi.org/10.1098/rspb.2012.1543>
- van Schaik, C. P. (2003). Local traditions in orangutans and chimpanzees: social learning and social tolerance. In D. M. Fragaszy & S. E. Perry (Eds.), *The Biology of Traditions: Models and Evidence* (pp. 297–328). Cambridge: Cambridge University Press.
- van Schaik, C. P., Burkart, J. M., Damerius, L., Forss, S. I. F., Koops, K., & van Noordwijk, M. A. (2016). The reluctant innovator: orang-utans and the phylogeny of creativity. *Philosophical Transactions of the Royal Society of London. Series B, Biological Sciences*, (March). <https://doi.org/10.1098/rstb.2015.0183>
- Vecchione, M., Guido, A., Barbaranelli, C., & Caprara, G. (2012). Gender differences in the Big Five personality development: A longitudinal investigation from late adolescence to emerging adulthood. *Personality and Individual Differences*, *53*(6), 740–746. <https://doi.org/10.1016/J.PAID.2012.05.033>
- Vlamings, P. H. J. M., Hare, B., & Call, J. (2009). Reaching around barriers: the performance of the great apes and 3–5-year-old children. *Animal Cognition*, *13*(2), 273–285. <https://doi.org/10.1007/s10071-009-0265-5>

- Wang, H., Zhao, J., Li, Y., & Li, C. (2015). Network centrality, organizational innovation, and performance: A meta-analysis. *Canadian Journal of Administrative Sciences / Revue Canadienne Des Sciences de l'Administration*, 32(3), 146–159. <https://doi.org/10.1002/cjas.1316>
- Want, S. C., & Harris, P. L. (2001). Learning from other people's mistakes: causal understanding in learning to use a tool. *Child Development*, 72(2), 431–443. <https://doi.org/10.1111/1467-8624.00288>
- Want, S. C., & Harris, P. L. (2002). How do children ape? Applying concepts from the study of non-human primates to the developmental study of 'imitation' in children. *Developmental Science*, 5(1), 1–14. <https://doi.org/10.1111/1467-7687.00194>
- Wascher, C. A. F. (2015). Individual performance in socio-cognitive tasks predicts social behaviour in carrion crows. *Behaviour*, 152(5), 615–634. <https://doi.org/10.1163/1568539X-00003245>
- Watson, S. K., Reamer, L. A., Marenco, M. C., Vale, G., Harrison, R. A., Lambeth, S. P., ... Whiten, A. (2017). Socially transmitted diffusion of a novel behavior from subordinate chimpanzees. *American Journal of Primatology*, 79(6), e22642. <https://doi.org/10.1002/ajp.22642>
- Watson, S. K., Vale, G. L., Hopper, L. M., Dean, L. G., Kendal, R. L., Price, E. E., ... Whiten, A. (2018). Chimpanzees demonstrate individual differences in social information use. *Animal Cognition*, in press, 1–12. <https://doi.org/10.1007/s10071-018-1198-7>
- Webb, C. E., Romero, T., Franks, B., & de Waal, F. B. M. (2017). Long-term consistency in chimpanzee consolation behaviour reflects empathetic personalities. *Nature Communications*, 8(1), 292. <https://doi.org/10.1038/s41467-017-00360-7>
- Weisberg, Y. J., Deyoung, C. G., & Hirsh, J. B. (2011). Gender differences in personality across the ten aspects of the Big Five. *Frontiers in Psychology*, 2, 178. <https://doi.org/10.3389/fpsyg.2011.00178>
- Weiss, A., Gartner, M. C., Gold, K. C., & Stoinski, T. S. (2013). Extraversion predicts longer survival in gorillas: an 18-year longitudinal study. *Proceedings. Biological Sciences / The Royal Society*, 280(1752), 20122231. <https://doi.org/10.1098/rspb.2012.2231>
- Weiss, A., Inoue-Murayama, M., King, J. E., Adams, M. J., & Matsuzawa, T. (2012). All too human? Chimpanzee and orang-utan personalities are not anthropomorphic projections. *Animal Behaviour*, 83(6), 1355–1365. <https://doi.org/10.1016/j.anbehav.2012.02.024>

- Weiss, A., & King, J. E. (2015). Great ape origins of personality maturation and sex differences: A study of orangutans and chimpanzees. *Journal of Personality and Social Psychology*, *108*(4), 648–664. <https://doi.org/10.1037/pspp0000022>
- Weiss, A., King, J. E., & Hopkins, W. D. (2007). A cross-setting study of chimpanzee (*Pan troglodytes*) personality structure and development: zoological parks and Yerkes National Primate Research Center. *American Journal of Primatology*, *69*(11), 1264–1277. <https://doi.org/10.1002/ajp.20428>
- Weiss, A., King, J. E., & Murray, L. (2011). *Personality and temperament in nonhuman primates*. (A. Weiss, J. E. King, & L. Murray, Eds.). New York, NY: Springer New York. <https://doi.org/10.1007/978-1-4614-0176-6>
- Weiss, A., Wilson, M. L., Collins, D. A., Mjungu, D., Kamenya, S., Foerster, S., & Pusey, A. E. (2017). Personality in the chimpanzees of Gombe National Park. *Scientific Data*, *4*, 1–18. <https://doi.org/10.1038/sdata.2017.146>
- Wells, D. L., McDonald, C. L., & Ringland, J. E. (2008). Color preferences in gorillas (*Gorilla gorilla gorilla*) and chimpanzees (*Pan troglodytes*). *Journal of Comparative Psychology*, *122*(2), 213–219. <https://doi.org/10.1037/0735-7036.122.2.213>
- Whiten, A. (2000). Primate culture and social learning. *Cognitive Science*, *24*(3), 477–508. [https://doi.org/10.1016/S0364-0213\(00\)00027-6](https://doi.org/10.1016/S0364-0213(00)00027-6)
- Whiten, A. (2017a). Culture extends the scope of evolutionary biology in the great apes. *Proceedings of the National Academy of Sciences*, *114*(30). <https://doi.org/10.1073/pnas.1620733114>
- Whiten, A. (2017b). Social learning and culture in child and chimpanzee. *Annual Review of Psychology*, *68*(1), 129–154. <https://doi.org/10.1146/annurev-psych-010416-044108>
- Whiten, A., Allan, G., Devlin, S., Kseib, N., Raw, N., & McGuigan, N. (2016). Social learning in the real-world: ‘over-imitation’ occurs in both children and adults unaware of participation in an experiment and independently of social interaction. *PLOS ONE*, *11*(7), e0159920. <https://doi.org/10.1371/journal.pone.0159920>
- Whiten, A., Ayala, F. J., Feldman, M. W., & Laland, K. N. (2017). The extension of biology through culture. *Proceedings of the National Academy of Sciences*, *114*(30). <https://doi.org/10.1073/pnas.1707630114>
- Whiten, A., Caldwell, C. A., & Mesoudi, A. (2016). Cultural diffusion in humans and other animals. *Current Opinion in Psychology*, *8*, 15–21. <https://doi.org/10.1016/j.copsyc.2015.09.002>

- Whiten, A., Custance, D. M., Gomez, J. C., Teixidor, P., & Bard, K. A. (1996). Imitative learning of artificial fruit processing in children (*Homo sapiens*) and chimpanzees (*Pan troglodytes*). *Journal of Comparative Psychology*, *110*(1), 3–14.
- Whiten, A., & Flynn, E. G. (2010). The transmission and evolution of experimental microcultures in groups of young children. *Developmental Psychology*, *46*(6), 1694–1709. <https://doi.org/10.1037/a0020786>
- Whiten, A., Goodall, J., McGrew, W. C., Nishida, T., Reynolds, V., Sugiyama, Y., ... Boesch, C. (1999). Cultures in chimpanzees. *Nature*, *399*(6737), 682–685. <https://doi.org/10.1038/21415>
- Whiten, A., McGuigan, N., Marshall-Pescini, S., & Hopper, L. M. (2009). Emulation, imitation, over-imitation and the scope of culture for child and chimpanzee. *Philosophical Transactions of the Royal Society of London. Series B, Biological Sciences*, *364*(1528), 2417–2428. <https://doi.org/10.1098/rstb.2009.0069>
- Whiten, A., Spiteri, A., Horner, V., Bonnie, K. E., Lambeth, S. P., Schapiro, S. J., & de Waal, F. B. M. (2007). Transmission of multiple traditions within and between chimpanzee groups. *Current Biology*, *17*(12), 1038–1043. <https://doi.org/10.1016/j.cub.2007.05.031>
- Wood, L. A., Harrison, R. A., Lucas, A. J., McGuigan, N., Burdett, E. R. R., & Whiten, A. (2016). “Model age-based” and “copy when uncertain” biases in children’s social learning of a novel task. *Journal of Experimental Child Psychology*, *150*, 272–284. <https://doi.org/10.1016/j.jecp.2016.06.005>
- Wood, L. A., Kendal, R. L., & Flynn, E. G. (2013a). Copy me or copy you? The effect of prior experience on social learning. *Cognition*, *127*(2), 203–213. <https://doi.org/10.1016/j.cognition.2013.01.002>
- Wood, L. A., Kendal, R. L., & Flynn, E. G. (2013b). Whom do children copy? Model-based biases in social learning. *Developmental Review*, *33*(4), 341–356. <https://doi.org/10.1016/j.dr.2013.08.002>
- Wood, L. A., Kendal, R. L., & Flynn, E. G. (2015). Does a peer model’s task proficiency influence children’s solution choice and innovation? *Journal of Experimental Child Psychology*, *139*, 190–202. <https://doi.org/10.1016/j.jecp.2015.06.003>
- Wood, W., & Eagly, A. H. (2002). A cross-cultural analysis of the behavior of women and men: Implications for the origins of sex differences. *Psychological Bulletin*, *128*(5), 699–727. <https://doi.org/10.1037/0033-2909.128.5.699>
- Yamamoto, S., Humle, T., & Tanaka, M. (2013). Basis for cumulative cultural evolution in chimpanzees: social

learning of a more efficient tool-use technique. *PloS One*, 8(1), e55768.
<https://doi.org/10.1371/journal.pone.0055768>

Yamanashi, Y., Teramoto, M., Morimura, N., Hirata, S., Inoue-Murayama, M., & Idani, G. (2016). Effects of relocation and individual and environmental factors on the long-term stress levels in captive chimpanzees (*Pan troglodytes*): monitoring hair cortisol and behaviors. *PLOS ONE*, 11(7), e0160029.
<https://doi.org/10.1371/journal.pone.0160029>

Yesil, S., & Sozbilir, F. (2013). An empirical investigation into the impact of personality on individual innovation behaviour in the workplace. *Procedia - Social and Behavioral Sciences*, 81, 540–551.
<https://doi.org/10.1016/j.sbspro.2013.06.474>

Zhou, J., Shin, S. J., Brass, D. J., Choi, J., & Zhang, Z.-X. (2009). Social networks, personal values, and creativity: evidence for curvilinear and interaction effects. *The Journal of Applied Psychology*, 94(6), 1544–1552.
<https://doi.org/10.1037/a0016285>

Appendices

Appendix 3.1: An example of the consent form administered to parents.



Department of Anthropology, Durham, DH1 3LE.

Contact Name (researcher): **Bruce Rawlings**

Tel. No.: 0191 334 1612, Fax: 0191 3341615

Email: **bruce.rawlings@durham.ac.uk**

Supervisors: **Dr. Rachel Kendal/ Prof. Emma Flynn**

Dear Parent/Guardian,

I am writing to you to ask if you would be willing to allow your child to participate in a study that I would like to run.

The study I intend to run is looking at whether children prefer to solve simple problems on their own or by learning from others, and what factors may influence this preference. The study involves myself presenting the children with a puzzle-box which contains a sticker reward to obtain from inside. Children can either watch me try to get the sticker out and then have a go themselves, or they can try to get it out themselves without watching me. Additionally, I would be very grateful if a parent/guardian would fill out a brief questionnaire about their child. We are interested in whether personality or social factors may play a role in influencing whether children are more likely to copy someone or try their own technique to get the sticker out and this questionnaire will help us look in to that. All data will be completely anonymous and all children will be given a sticker after their go.

The study would be quick, designed to be enjoyable and I will work with the children individually, in an open but quiet area of the classroom. Staff members will be able to freely access this space. This puzzle-box has been used in studies like this one around the local area, and children find it fun and engaging. However, should your child wish to, s/he will be free to withdraw at any time.

The sessions will be video-taped so that I can use this as a memory aid for each child's behaviour. If you wish to view the footage arrangements can be made to do so. The videos will be destroyed at the end of the study along with the questionnaire data. I may wish to use the footage to illustrate my study's procedure and findings to other academics. If you **do not** wish for video footage of your child to be used in academic presentations, please complete the return slip below. I have had a full Disclosure and Barring Service check (formerly CBS check) and this has been verified by the staff at the school. The study I am running is titled 'Establishing predictors of learning style: An investigation of the intrinsic and extrinsic

factors influencing when we learn from others and from whom we learn' (supervised by Dr. Rachel Kendal and Prof. Emma Flynn at Durham University, both of whom have been a part of several such studies) and has full ethical approval from the University. Finally, a report with the study's findings will be sent to the school at the end of the research.

I have met with, and fully briefed, the head teacher who has given consent for me to work with your child's class. If you are **willing** for your child to participate in the study, please complete the slip below and return it to a member of the school staff within a week of receipt. **I would be glad to answer any questions you may have regarding this study in the meantime, so please do not hesitate to e-mail me using the details at the top of this letter.**

Many thanks,

Bruce Rawlings

PhD Candidate

Department of Anthropology / School of Education

Email : bruce.rawlings@durham.ac.uk

Supervisors: Dr. Rachel Kendal (0191 3341627) and Prof. Emma Flynn (0191 3343239)

.....
Please return this slip if you are willing for your child to participate.

If you are willing for your child to participate but you are unwilling for video footage of him/her to be shown in academic presentations please return this slip marking the relevant option below.

Child's Name: _____

- I am WILLING to allow my child to participate in the study
- I AM WILLING for my child to participate but DO NOT want video footage of him/her to be shown to other academics

Signed: _____ Date: _____

Appendix 4.1: The personality questionnaire administered to parents of participants, as developed by Asendorpf & van Aiken (2003). Wording was corrected for versions administered to teachers.

BFI-46-A: Here are some statements that may or may not describe what your child is like. In the blank next to each statement, write the number that shows how much you agree or disagree that it describes your child. For example, do you agree that your child is *self-assertive*? Write a *5* if you agree strongly, a *4* if you agree a little, a *3* if you neither agree nor disagree, a *2* if you disagree a little, or a *1* if you disagree strongly. Try to be as objective as possible. All questionnaires will be kept strictly confidential.

1 Disagree Strongly	2 Disagree a little	3 Neither agree nor disagree	4 Agree a little	5 Agree strongly
----------------------------------	----------------------------------	---	-------------------------------	-------------------------------

I see my child as someone who...

- | | |
|---|---|
| <p>1. ____ Is vital, energetic, lively</p> <p>2. ____ Is fearful and anxious</p> <p>3. ____ Is persistent in activities, does not give up easily</p> <p>4. ____ Tends to brood and ruminate or worry</p> <p>5. ____ Is resourceful in initiating activities</p> <p>6. ____ Tends to yield and give in in conflicts</p> <p>7. ____ Is playful, thinks ahead</p> <p>8. ____ Can be trusted, is dependable</p> <p>9. ____ Is considerate and thoughtful of other children</p> <p>10. ____ Becomes strongly involved in what s/he does</p> <p>11. ____ Is inhibited and constricted</p> <p>12. ____ Has high standards of performance for self</p> <p>13. ____ Is helpful and cooperative</p> | <p>14. ____ Is self-assertive</p> <p>15. ____ Is curious and exploring; open to new experiences</p> <p>16. ____ Teases other children</p> <p>17. ____ Is attentive and able to concentrate</p> <p>18. ____ Gets along well with other children</p> <p>19. ____ Tends to go to pieces under stress</p> <p>20. ____ Is easily offended, sensitive to criticism</p> <p>21. ____ Is competent, skillful</p> <p>22. ____ Is creative in perception, thought, work or play</p> <p>23. ____ Become anxious in unpredictable environments</p> <p>24. ____ Can recoup or recover after stress</p> <p>End</p> |
|---|---|

Appendix 4.2: Chapter 4 full details of regression models

The following provides the full details for all regression models conducted within the results section of Chapter 4, along with the additional Hook task methods regression analysis conducted with personality traits added as covariates.

4.2.1 All participants' behaviours on the MMB combined

Successful attempts (max. 10)

Overall, participants exhibited a mean of 6.72 ($SD = 2.15$) successful attempts over their 10 attempts. The regression model was significant fit ($R^2 = .177$, $F = 7.335$, $p < .001$). Age ($\beta = .156$, $p = .007$) positively predicted the number of successful attempts, indicating that older children had more successful attempts than younger children. Learning strategy choice was also a significant predictor ($\beta = -.400$, $p < .001$); children who elected for social demonstrations ($M = 7.36$, $SD = 1.99$) had more successful attempts than those who did not ($M = 5.71$, $SD = 2.02$). Sex and personality ratings did not predict the number of successful attempts.

Tools used (max. 4)

Children used a mean of 2.40 ($SD = 0.95$) tools over their 10 attempts. The model was significant ($R^2 = .055$, $F = 2.002$, $p = .046$). Learning strategy choice was a significant predictor ($\beta = .155$, $p = .013$), with children who elected for demonstrations ($M = 2.28$, $SD = 0.89$) using fewer tools than those who did not ($M = 2.59$, $SD = 1.01$). Age did not predict the number of tools children used, but sex did ($\beta = -.123$, $p = .05$): males ($M = 2.56$, $SD = 0.93$) used more tools than females ($M = 2.25$, $SD = 0.95$), but this was not considered significant under the false discovery rate. No personality trait was a significant predictor.

Entrances used (max. 5)

Overall, children used a mean of 2.47 ($SD = 1.10$) different MMB entrances across their 10 attempts. The model was significant ($R^2 = .210$, $F = 9.084$, $p < .001$). Learning strategy was a significant predictor ($\beta = .440$, $p <$

.001), with children who elected for social demonstrations ($M = 2.08$, $SD = 0.89$) using fewer entrances than children who elected for no demonstrations ($M = 3.08$, $SD = 1.14$). Openness to experience also positively predicted the number of entrances used ($\beta = .141$, $p = .039$), but this was not considered significant with the application of the false discovery rate, but no other personality trait did. Age ($\beta = .053$, $p = .917$) and sex ($\beta = .126$, $p = .910$) did not predict the number of tools used.

Exits used (max. 6)

Children used a mean of 1.65 ($SD = 0.91$) different MMB exits across their 10 attempts. The model was a significant ($R^2 = .191$, $F = 8.066$, $p < .001$). Age predicted the number of exits children used ($\beta = .131$, $p = .022$), with older children using more exits than younger children, but this was not considered significant with the application of the false discovery rate, potentially indicating older children used more exits than younger children. Learning strategy, as a significant predictor ($\beta = .338$, $p < .001$) revealed that children who elected for demonstrations ($M = 1.38$, $SD = 0.79$) used fewer exits than those who did not ($M = 2.07$, $SD = 0.93$). Extraversion ($\beta = .127$, $p = .065$) and agreeableness ($\beta = .113$, $p = .067$) showed a trend in positively predicting the number of exits used. Sex and the remaining personality traits were not significant predictors.

4.2.2 Children who elected for social demonstrations

Exact imitations (max. 10)

Overall, children who elected for social demonstrations displayed a mean of 3.77 ($SD = 3.101$) exact imitations within their 10 MMB attempts. The linear regression model was not significant ($R^2 = .020$, $F = .474$, $p = .853$). Age, sex and personality traits did not predict the number of imitations.

Tool innovations (max. 10)

Children who elected for social demonstrations displayed a mean of 4.23 ($SD = 3.23$) tool innovations over their 10 attempts. Neither age, sex nor any personality trait predicted the number of tool innovations, and the model was not significant ($R^2 = .018$, $F = 0.425$, $p = .886$).

Entrance innovations (max. 10)

Children who elected for social demonstrations displayed a mean of 2.50 ($SD = 2.54$) entrance innovations. Age and sex did not predict the number of entrance innovations. Additionally, no personality trait predicted the number of entrance innovations, although openness to experience (positively) approached significance ($\beta = .188, p = .058$). The model was not significant ($R^2 = .055, F = 1.360, p = .225$).

Exit innovations (max. 10)

Generally, children were unlikely to deviate from the observed exit (mean exit innovations = 0.89, $SD = 1.98$). The model was significant ($R^2 = .130, F = 3.528, p = .001$). Age positively predicted the number of exit innovations ($\beta = .295, p < .001$). Additionally, openness to experience positively predicted the number of exit innovations ($\beta = .215, p = .024$). No other variables were significant.

Deviation score (max. 30)

Children's mean deviation score was 7.61 ($SD = 5.78$). The overall model was not significant ($R^2 = .031, F = 1.783, p = .093$). However, age ($\beta = .176, p = .024$) and openness to experience ($\beta = .210, p = .032$) positively predicted children's deviation score. No other variables were significant.

Children who elected for no demonstrations

Number of tools (max. 4)

Children who elected for no demonstrations used a mean of 2.59 ($SD = 1.01$) different tools across their 10 attempts. Neither age, sex nor personality predicted the number of tools children who elected for no demonstrations used, and the model was not significant ($R^2 = .042, F = 0.631, p = .729$).

Number of entrances (max. 5)

Children who elected for no demonstrations used a mean of 3.08 ($SD = 1.14$) different entrances across their 10 attempts. Age, sex and personality did not predict the number of different entrances children who elected for no demonstrations used, and the model was not significant ($R^2 = .033$, $F = 0.485$, $p = .844$).

Number of exits (max. 6)

Children who elected for no demonstrations used a mean of 2.07 ($SD = .93$) different exits across their 10 attempts. Age and sex did not predict the number of different exits children who elected for no demonstrations used. Agreeableness positively predicted the number of exits used ($\beta = .287$, $p = .009$), but with the application of the false discovery rate, this was not considered significant. No other personality trait was a significant predictor, and the model overall was not significant ($R^2 = .101$, $F = 1.627$, $p = .136$).

Composite 'novelty' score (max. 16)

Children who elected for no demonstrations used a mean of 7.74 ($SD = 2.23$) different tools, entrances and exits across their 10 attempts. None of the variables were significant predictors, and the model was not significant ($R^2 = .057$, $F = 0.865$, $p = .537$).

Number of repetitions (max. 9)

Children who elected for no demonstrations used a mean of 3.69 ($SD = 1.01$) repetitions across the 9 attempts following their first attempt. Again, none of the variables were significant predictors, and the model was not significant ($R^2 = .059$, $F = 0.905$, $p = .506$).

4.3 The Hook Task

4.3.1 Overall performance and personality

Altogether 82% ($N = 230$) of participants succeeded in retrieving the sticker reward with the pipe cleaner, and 18% ($N = 52$) failed to retrieve the reward. Given the age range of participants, is in line with findings from other studies (Beck et al., 2011, 2016).

The binary logistic regression model approached significance, (Nagelkerke's $R^2 = .144$, $X^2 = 13.711$, $p = .057$). The independent variables correctly predicted 99.6% of those who succeeded, but 0% of those who failed. Age (odds ratio = 1.363, Wald = 4.775, $p = .029$) positively predicted success, although this was not considered significant with the application of the false discovery rate. Agreeableness (odds ratio = 1.927, Wald = 4.235, $p = .040$) also positively predicted success, although this was also not considered significant with the application of the false discovery rate. Sex (odds ratio = 1.363, Wald = 4.775, $p = .029$), not any other personality traits were significant predictors (all $p < .05$); conscientiousness (odds ratio = .690, Wald = 1.491, $p = .222$), extraversion (odds ratio = 1.198, Wald = .377, $p = .539$), openness to experience (odds ratio = 1.193, Wald = .332, $p = .565$), neuroticism (odds ratio = .737, Wald = 1.720, $p = .190$).

4.4 Alternate Uses

4.4.1 Overall performance

Fluency

Overall, children named an average of 4.94 ($SD = 3.06$) different uses for a paperclip. The regression model was significant, ($R^2 = .055$, $F = 2.259$), $p = .030$. Age (beta = .345, $p = .032$) positively predicted fluency scores, although with the application of the false discovery rate this was not considered significant. Similarly, sex (beta = .345, $p = .041$) was also a predictor with Males ($M = 5.38$, $SD = 3.68$) displaying higher fluency scores than females ($M = 4.53$, $SD = 2.28$), this was also not considered significant with the application of the false discovery rate, tentatively suggesting that older children and males provided more total uses for a paperclip than younger children and females, respectively. No personality trait predicted fluency scores on the Alternate Uses task; agreeableness (beta = .021, $p = .754$), conscientiousness (beta = -.035, $p = .638$), extraversion (beta = .250, $p = .457$), openness to experience (beta = .133, $p = .075$), neuroticism (beta = .064, $p = .341$).

Originality

Children scored an Alternate Uses originality mean of 4.07 ($SD = 5.74$). The regression model was not significant, ($R^2 = .036$, $F = 1.480$), $p = .174$. Age (beta = .470, $p = .120$), sex (beta = -.100, $p = .109$) and personality did not predict children's Alternate Uses originality scores (all $p > .05$): agreeableness (beta = .006, $p = .925$), conscientiousness (beta = -.027, $p = .722$), extraversion (beta = .096, $p = .200$), openness to experience (beta = .090, $p = .200$), neuroticism (beta = .069, $p = .310$).

4.4 Hook task methods: Regression analysis conducted with personality traits added as covariates

When controlling for personality; compared to using the hook method, older children were less likely to fail than younger children (odds ratio = .625, Wald = 9.093, $p < .001$) and were less likely to use the dragging technique (odds ratio = .513, Wald = 17.482, $p = .003$). Children who elected for no demonstrations were also still more likely to use the hook method and children who elected for social demonstrations were more likely to use the dragging technique (odds ratio = 3.719, Wald = 11.016, $p = .001$).

Appendix 5.1: Chapter 5 full details of regression models

The following provides the full details for all regression models conducted within the results section of Chapter 5, as well as details of the analysis investigating the relationship between social network measures and performance on the Hook and Alternate Uses tasks.

5.1.1 All participants' behaviours on the MMB combined

Successful attempts (max. 10)

Overall, participants displayed a mean of 6.76 ($SD = 2.06$) successes over their 10 attempts. The regression model was significant ($R^2 = .267$, $F = 7.443$, $p = .001$). Age (beta = .245, $p = .017$) positively predicted the number of successful attempts, indicating that older children were more successful than younger children. Learning strategy choice was also a significant predictor (beta = -.417, $p < .001$); children who elected for social demonstrations ($M = 7.43$, $SD = 1.87$) displayed more successful attempts than those who did not ($M = 5.90$, $SD = 1.99$). Degree centrality (beta = -.216, $p = .041$) significantly negatively predicted the number of successful attempts, although this was not considered significant under the application of the false detection rate, potentially indicating that children with a higher degree centrality value were less successful than children with a lower degree centrality value. Sex ($p = .612$) and betweenness ($p = .726$) did not predict the number of successful attempts.

Tools used (max. 5)

Children used a mean of 2.34 ($SD = 0.91$) different tools over their 10 attempts. The regression model was significant ($R^2 = .117$, $F = 3.574$, $p = .013$). Age (beta = -.255, $p = .014$) negatively predicted the number of tools used, indicating that older children used fewer tools than younger children. Degree centrality (beta = .302, $p = .003$) positively predicted the number of tools used, signifying that children with higher degree centrality values used more tools than those with lower degree centrality values. Sex

($p = .364$), betweenness ($p = .711$) and learning strategy ($p = .170$) did not predict the number of tools children used on the MMB.

Entrances used (max. 5)

Children used a mean of 2.46 ($SD = 1.11$) different entrances over their 10 attempts. The regression model was significant ($R^2 = .132$, $F = 5.245$, $p = .002$). Learning strategy choice was a significant predictor ($\beta = -.379$, $p < .001$); children who elected for social demonstrations ($M = 2.08$, $SD = 0.86$) used fewer entrances than children who elected for no demonstrations ($M = 3.00$, $SD = 1.21$). Degree centrality ($p = .192$), betweenness ($p = .330$), age ($p = .640$) and sex ($p = .591$) did not predict the number of entrances used.

Exits used (max. 6)

Children used a mean of 1.70 ($SD = 0.95$) different exits over their 10 attempts. The regression model was significant ($R^2 = .189$, $F = 6.20$, $p = .001$). Learning strategy choice was a significant predictor ($\beta = -.309$, $p < .001$); children who elected for demonstrations ($M = 1.47$, $SD = 0.92$) used fewer exits than children who did not ($M = 2.01$, $SD = 0.90$). Degree centrality was also a significant positive predictor ($\beta = .307$, $p = .002$), indicating that children with higher degree centrality values used more exits than those with lower degree centrality values. Age ($p = .864$), sex ($p = .365$) and betweenness ($p = .517$) did not predict the number of exits used.

5.1.2 Children who elected for a demonstration

Exact imitations (max. 10)

Children who elected for social demonstrations displayed a mean of 3.92 ($SD = 3.15$) exact imitations (i.e. the same tool, entrance and exit) across their 10 attempts. The regression model was not significant ($R^2 = .087$, $F = 1.978$, $p = .140$). However, degree centrality ($\beta = -.271$, $p = .044$) significantly negatively predicted the number of exact imitations, although this was not considered significant under the application of the false detection rate, potentially indicating that children with a higher degree centrality value made fewer exact imitations. Age ($p = .197$), sex ($p = .421$), and betweenness ($p = .092$) did not predict the number of exact imitations children who elected for social demonstrations made.

Tool innovations (max 10)

Overall, children who elected for demonstrations exhibited a mean of 4.09 ($SD = 3.16$) tool innovations across their 10 attempts. The regression model was not significant ($R^2 = .044$, $F = 0.957$, $p = .459$). Neither age ($p = .411$), sex ($p = .872$), degree centrality ($p = .177$) nor betweenness ($p = .173$) predicted the number of tool innovations children who elected for demonstrations made.

Entrance innovations (max. 10)

Children who elected for social demonstrations displayed a mean of 2.66 ($SD = 2.69$) entrance innovations across their 10 attempts. The regression model was not significant ($R^2 = .028$, $F = 0.594$, $p = .659$). Age ($p = .835$), sex ($p = .983$), degree centrality ($p = .330$) and betweenness ($p = .270$) did not predict the number of exit innovations children who elected for demonstrations made.

Exit innovations (max.10)

Overall, children were unlikely to deviate from the witnessed exit (mean exit innovations = 1.01, $SD = 2.04$). The regression model ($R^2 = .105$, $F = 2.436$) was not significant, $p = .091$. Degree centrality (beta = .285, $p = .034$) positively predicted the number of exit innovations, indicating that children with higher degree centrality values were more likely to deviate from the observed exit than children with a lower degree centrality score. Age ($p = .628$), sex ($p = .983$), betweenness ($p = .962$) did not predict the number of exit innovations children who elected for demonstrations made.

Deviation score (max. 30)

Children's mean deviation score was 7.76 ($SD = 5.79$). The regression model was not significant ($R^2 = .075$, $F = 1.679$, $p = .190$). Degree centrality (beta = .260, $p = .049$) significantly positively predicted children's deviation score, although this was not considered significant under the application of the false detection rate, potentially indicating that children with higher degree centrality values were more likely to deviate from the demonstrated methods than those with lower degree centrality values. Age ($p = .702$), sex ($p = .923$) and betweenness ($p = .199$) did not predict the number of exits used.

5.1.3 Children who elected for no demonstrations

Number of tools (max. 4)

Children who elected for no demonstrations used a mean of 2.48 ($SD = 1.01$) different tools across their 10 attempts. The regression model was not significant ($R^2 = .069$, $F = 1.148$, $p = .356$). Age ($p = .738$), sex ($p = .149$), degree centrality ($p = .320$) and betweenness ($p = .709$) did not predict the number of tools children who elected for no demonstrations used.

Number of entrances (max. 5)

Children who elected for no demonstrations used a mean of 2.96 ($SD = 1.21$) different entrances across their 10 attempts. The regression model was not significant ($R^2 = .020$, $F = 0.314$, $p = .868$). Age ($p = .783$), sex ($p = .754$), degree centrality ($p = .781$) and betweenness ($p = .373$) did not predict the number of entrances children who elected for no demonstrations used.

Number of different exits (max. 6)

Overall, children who selected no demonstrations were relatively limited in the number of exits they used ($M = 2.01$, $SD = .90$). The regression model was not significant ($R^2 = .043$, $F = 0.689$, $p = .605$). Age ($p = .357$), sex ($p = .599$), degree centrality ($p = .214$) and betweenness ($p = .367$) did not predict the number of exits children who elected for no demonstrations used.

Composite 'novelty' score (max. 16)

Children who elected for no demonstrations used a mean of 7.75 ($SD = 2.20$) different tools, entrances and exits across their 10 attempts. The regression model was not significant ($R^2 = .033$, $F = 0.527$, $p = .715$) with none of the variables predicting children who elected for no demonstrations' novelty score: Age ($p = .706$), sex ($p = .482$), degree centrality ($p = .271$) and betweenness ($p = .494$).

Number of repetitions (max. 9)

Overall, children who elected for no demonstrations repeated a previously used method (i.e. same tool, entrance and exit) a mean of 3.97 ($SD = 2.42$) times. The regression model was significant ($R^2 = .109$, $F = 1.894$, $p = .015$). Degree centrality (beta = $-.338$, $p = .016$) significantly negatively predicted the number of repetitions, indicating that children with higher degree centrality values were less likely to repeat previously used methods than children with lower degree centrality values. Age ($p = .421$), sex (p

= .476), and betweenness ($p = .234$) did not predict the number of repetitions children who elected for no demonstrations made.

5.2 The relationship between social network measures and performance on the Hook Task and Alternate Uses task (all participants)

5.2.1 Hook Task

Hook Task Success

Overall, 78% ($N = 121$) of children succeeded in retrieving the sticker reward from the Hook Task, and 21.9% ($N = 34$) failed to retrieve the reward. The binary logistic regression model was a poor fit of the data (Nagelkerke's $R^2 = .068$) and correctly predicted 100% of those that elected for a demonstration, but 0% of those that did not. Age ($p = .077$), sex ($p = .165$), degree centrality ($p = .512$) and betweenness ($p = .238$) did not predict children's success or failure on the Hook Task.

Hook Task method

Including all participants, 63% ($N = 97$) used the hook technique, 13% ($N = 20$) used the dragging technique, and 3% ($N = 4$) used the alternative technique (22% failed to retrieve the reward).

Multinomial logistic regression showed the overall model as a moderate fit (Nagelkerke's $R^2 = .164$, $X^2 = 23.536$, $p = .024$) and significant. Age ($X^2 = 10.756$, $p < .013$) was a significant predictor of the technique used, but sex was not. Age positively predicted the propensity to use the hook technique compared to the dragging technique (odds ratio = .578, Wald = 4.035, $p = .045$), suggesting older children were more likely to manipulate the pipe cleaner to create a tool, whilst younger children were more likely to attempt to use the pipe cleaner in its original state. Age also positively predicted the propensity to use the hook technique compared to the failing (odds ratio = .632, Wald = 4.270, $p = .039$), suggesting older children were more likely to manipulate the pipe cleaner to create a tool, whilst

younger children were more likely to fail. No other comparisons, including degree centrality, betweenness, sex or age were significant (both $p > .05$).

5.2.2 Alternate Uses Task

Fluency

Overall, children scored an Alternate Uses fluency mean score of 4.72, $SD = 2.58$. The regression model was not significant ($R^2 = .001$, $F = 0.319$, $p = .857$). Age ($p = .664$), sex ($p = .759$), degree centrality ($p = .805$) and betweenness ($p = .401$) did not predict children's Alternate Uses fluency scores.

Originality

Overall, children scored an Alternate Uses originality mean score of 3.59, $SD = 4.65$. The regression model was not significant ($R^2 = .021$, $F = 0.714$, $p = .589$). Age ($p = .277$), sex ($p = .680$), degree centrality ($p = .954$) and betweenness ($p = .356$) did not predict children's Alternate Uses originality scores.

Appendix 6.1 An example of the personality questionnaire administered to carestaff.

ASSESSMENT OF PERSONALITY IN CHIMPANZEES

Chimpanzee personality assessments can be made with this questionnaire by assigning a numerical score for all of the personality traits listed on the following pages. Make your judgments on the basis of your own understanding of the trait guided by the short clarifying definition following each trait. The chimpanzee's own behaviors and interactions with other chimpanzees should be the basis for your numerical ratings. Use your own subjective judgment of typical chimpanzee behavior to decide if the chimpanzee you are scoring is above, below, or average for a trait. The following seven-point scale should be used to make your ratings.

1. **Displays either total absence or negligible amounts of the trait.**
2. **Displays small amounts of the trait on infrequent occasions.**
3. **Displays somewhat less than average amounts of the trait.**
4. **Displays about average amounts of the trait.**
5. **Displays somewhat greater than average amounts of the trait.**
6. **Displays considerable amounts of the trait on frequent occasions.**
7. **Displays extremely large amount of the trait.**

Please give a rating for each trait even if your judgment seems to be based on a purely subjective impression of the chimpanzee and you are somewhat unsure about it. Indicate your rating by placing a cross in the box underneath the chosen number.

Finally, do not discuss your rating of any particular chimpanzee with anyone else. This restriction is necessary in order to obtain valid reliability coefficients for the traits.

Chimpanzee's name _____ Rater's name _____

Date _____

Active: Spends little time idle and seems motivated to spend considerable time either moving around or engaging in some overt, energetic behavior.

1 2 3 4 5 6 7

Least Most

Affectionate/Friendly: Seems to have a warm attachment or closeness with other chimpanzees. This may entail frequent grooming, touching, embracing, or lying next to others.

Least Most

Affiliative: Agreeable, sociable. Appears to like the company of others. Seeks out social contact with, or showing preference for, another animal; for example, playing walking next to, or sitting with another animal.

Least Most

Aggressive: Often initiates fights or other menacing and agonistic encounters with other chimpanzees

Least Most

Anxious: Hesitant, indecisive, tentative, jittery.

Least Most

Autistic: Does not make eye contact, and/or not well integrated into social group.

Least Most

Bold: Daring, not restrained or tentative. Not timid, shy or coy.

Least Most

Bullying: Overbearing and intimidating towards younger or lower ranking chimpanzees.

Least 1 2 3 4 5 6 7 Most

Calm: Equable, restful: Reacts to others in an even, calm way; is not easily disturbed or agitated.

Least 1 2 3 4 5 6 7 Most

Cautious: Exhibits a more careful measured approach to investigating things.

Least 1 2 3 4 5 6 7 Most

Considerate/Kind: Often consoles others in distress to provide reassurance.

Least 1 2 3 4 5 6 7 Most

Deceptive: Deceives others for his/her own benefit.

Least 1 2 3 4 5 6 7 Most

Defiant: Assertive or contentious in a way inconsistent with the usual dominance order. Maintains these actions despite unfavorable consequences or threats from others.

Least 1 2 3 4 5 6 7 Most

Dependent: Often relies on other chimpanzees for leadership, reassurance, touching, embracing and other forms of social support.

Least 1 2 3 4 5 6 7 Most

Depressed: Often appears isolated, withdrawn, sullen, brooding and has reduced activity.

Least 1 2 3 4 5 6 7 Most

Dominant: Able to displace, threaten or take food from other chimpanzees. Or subject may express high status by decisively intervening in social interactions.

Least 1 2 3 4 5 6 7 Most

Eccentric: Shows stereotypies or unusual mannerisms.

Least 1 2 3 4 5 6 7 Most

Excitable: Easily aroused to an emotional state.

Least 1 2 3 4 5 6 7 Most

Fearful: Subject reacts excessively to real or imagined threats by displaying behaviors such as screaming, grimacing, running away or other signs of anxiety or distress.

Least 1 2 3 4 5 6 7 Most

Human oriented: Very interested in human activities around their enclosure. Solicits support from humans.

Least 1 2 3 4 5 6 7 Most

Impulsive: Often displays some spontaneous or sudden behavior that could not have been anticipated.

1 2 3 4 5 6 7

Least Most

Inquisitive/Curious: Readily explores new situations, objects or animals.

Least Most

Intelligent: Quick and accurate in judging and comprehending both social and nonsocial situations.

Least Most

Inventive: More likely than others to engage in novel behaviors. E.g. Using new devices or materials in their enclosure.

Least Most

Irritable: Often seems in a bad mood or is impatient and easily provoked to anger exasperation and consequent agnostic behavior.

Least Most

Jealous/Attention-seeking: Often troubled by others who are in a desirable or advantageous situation such as having food, a choice location or access to social groups. May attempt to disrupt activities or make noise to get attention.

Least Most

Manipulative: Is able to get others to do things without using force.

Least Most

Methodical: Does things in a logical, organized manner following a consistent goal.

Least 1 2 3 4 5 6 7 Most

Mischievous: Engages in activities or behavior with the goal of provoking negative reactions from someone or doing something that has previously been established as not socially acceptable.

Least 1 2 3 4 5 6 7 Most

Persistent: Tends to continue in a course of action, task, or strategy for a long time or continues despite external interference.

Least 1 2 3 4 5 6 7 Most

Playful: Is eager to engage in lively, vigorous, sportive or acrobatic behaviors with or without other chimpanzees.

Least 1 2 3 4 5 6 7 Most

Predictable: Behavior is consistent and steady over extended periods of time. Does little that is unexpected or deviates from its usual behavioral routine.

Least 1 2 3 4 5 6 7 Most

Protective: Shows concern for other chimpanzees and often intervenes to prevent harm or annoyance from coming to them.

Least 1 2 3 4 5 6 7 Most

Relaxed: Does not show restraint in postures and movements. Is not tense.

Least **1** **2** **3** **4** **5** **6** **7** Most

Self-caring: Shows high, but healthy level of self-grooming and cleanliness.

Least **1** **2** **3** **4** **5** **6** **7** Most

Sexual: Engages in frequent copulations and/or masturbation.

Least **1** **2** **3** **4** **5** **6** **7** Most

Socially-inept: Acts inappropriately in a social setting.

Least **1** **2** **3** **4** **5** **6** **7** Most

Solitary: Prefers to spend considerable time alone not seeking or avoiding contact with other chimpanzees.

Least **1** **2** **3** **4** **5** **6** **7** Most

Stingy: Is excessively desirous or covetous of food, favored locations, or other resources in enclosure. Is unwilling to share these resources with others.

Least **1** **2** **3** **4** **5** **6** **7** Most

Temperamental/Moody: Is inconsistent and wildly/varying in its moods and behaviors.

Least **1** **2** **3** **4** **5** **6** **7** Most

Timid: Lacks confidence is easily alarmed and is hesitant to venture into new social or nonsocial situations.

Least **1** **2** **3** **4** **5** **6** **7** Most

Appendix 6.2 ICC (3,k) inter rater reliability values for T1 between April 2006-December 2008 (taken from Freeman et al. 2013) and for T2, between September 2015-December 2016 (collected for this thesis).

Personality trait	ICC (3,k) values from T1: 2006-2008	ICC (3,k) values from T2: Sept 2015-Dec 2016
Active	.85	.84
Affectionate/Friendly	.55	.68
Affiliative	.42	.63
Aggressive	.67	.91
Anxious	.60	.85
Autistic	.35	.35
Bold	.80	.87
Bullying	.76	.91
Calm	.56	.78
Cautious	.70	.82
Considerate/Kind	.48	.79
Deceptive	.58	.96
Defiant	.55	.89
Dependent	.56	.78
Depressed	.52	.41
Dominant	.85	.89
Eccentric	.44	.70
Excitable	.68	.67
Fearful	.65	.83
Human oriented	.75	.78
Impulsive	.61	.77
Inquisitive/Curious	.67	.63
Intelligent	.64	.79
Inventive	.66	.75
Irritable	.61	.82
Jealous/Attention-Seeking	.72	.82
Manipulative	.67	.82
Methodical	.36	.56
Mischievous	.71	.84
Relaxed	.61	.72
Self-caring	.36	.56
Playful	.71	.72
Protective	.55	.72
Relaxed	.61	.73
Self-caring	.36	.56
Sexual	.66	.69
Socially-inept	.47	.39

Solitary	.60	.52
Stingy	.71	.76
Temperamental/Moody	.65	.82
Timid	.70	.87

Appendix 7.1: Chapter 7 full details of regression models

The following provides the full details for all regression models conducted within the results section of Chapter 7, as well as details of analysis by each type of video demonstration (Blue Spot and Green Chequered), separately (Experiment 1).

7.1.1 Experiment 1: Observations of video demonstrations (social information)

7.2.1.1 Time spent observing video demonstrations

Both videos combined

Overall, chimpanzees spent a mean time of 211.33s ($SD = 324.86$) observing both of the video demonstrations. The model was significant ($R^2 = .309$, $F = 2.238$, $p = .045$). Ratings of dominance predicted the propensity to observe video demonstrations dominance ($\beta = .427$, $p = .042$), although this was not considered significant under the false discovery rate. Social group ($\beta = -.001$, $p = .996$), sex ($\beta = -.355$, $p = .085$), nor any other personality trait predicted the total time spent watching the video demonstrations agreeableness ($\beta = .036$, $p = .867$), extraversion ($\beta = -.350$, $p = .100$), methodical ($\beta = .110$, $p = .507$), openness ($\beta = -.145$, $p = .531$) and reactivity/undependability ($\beta = .016$, $p = .945$).

Blue spotted video

Overall, chimpanzees spent a mean time of 132.37s ($SD = 240.35$) observing the Blue spots video demonstrations. The model was not significant ($R^2 = .278$, $F = 1.925$, $p = .083$). Dominance ($\beta = .403$, $p = .060$) approached in being a significant predictor, suggesting that chimpanzees rated as dominant tended to spend more time observing the Blue Spotted video demonstrations than those rated as less dominant. Sex ($\beta = -.254$, $p = .224$), social group ($\beta = .017$, $p = .907$), agreeableness ($\beta = .076$, $p = .730$), extraversion ($\beta = -.388$, $p = .076$), methodical ($\beta = .199$, $p = .483$), openness ($\beta =$

= -.108, $p = .648$) and reactivity/undependability (beta = .026, $p = .916$), did not predict the time spent observing the Blue Spotted video demonstrations.

Green Chequered video

Overall, chimpanzees spent a mean time of 78.96s ($SD = 106.11$) observing the Green Chequered video demonstrations. Sex was a significant predictor (beta = -.512, $p = .016$); females ($M = 112.65$, $SD = 125.63$), spent more time watch the Green Chequered video demonstration than males ($M = 40.87$, $SD = 61.39$). Ratings of dominance (beta = .396, $p = .063$) approached significance, suggesting that dominant chimpanzees tended to spend more time observing the Green Chequered video demonstrations than those rated as less dominant individuals. Social group (beta = -.040, $p = .779$), agreeableness (beta = -.062, $p = .777$), extraversion (beta = -.194, $p = .364$), methodical (beta = .067, $p = .688$), openness (beta = -.200, $p = .396$) and reactivity/undependability (beta = .008, $p = .975$), did not predict the time spent observing the Green Chequered video demonstrations.

7.1.2 Experimental groups: Effects of sex, social group and personality on puzzle-box interactions

7.1.2.1 Number of observations of conspecifics' task interactions

Overall, chimpanzees observed conspecifics interact with the Lazy-Alpha a mean of 47.48 ($SD = 37.51$) times. The model was not significant ($R^2 = .330$, $F = 1.970$, $p = .076$). Social group (beta = .307, $p = .041$) predicted the number of times individuals observed conspecifics solving the task, suggesting groups differed in their propensity to observe others at the task. Sex (beta = -.135, $p = .563$), time spent observing video demonstrations (beta = .066, $p = .692$), nor any personality traits were significant predictors; agreeableness (beta = .227, $p = .333$), dominance, (beta = -.404, $p = .091$), extraversion (beta = .167, $p = .460$), methodical (beta = -.267, $p = .460$, openness (beta = .066, $p = .784$), reactivity/undependability (beta = .443, $p = .073$).

7.1.2.2 Number of observations of conspecifics solving the task

Overall, chimpanzees observed conspecifics solve the Lazy-Alpha a mean of 24.63 ($SD = 22.10$) times. The model was not significant ($R^2 = .282$, $F = 1.571$, $p = .161$). Social group ($\beta = .256$, $p = .096$), sex ($\beta = -.179$, $p = .462$), time spent observing video demonstrations ($\beta = .065$, $p = .708$), nor any personality traits were significant predictors; agreeableness ($\beta = .191$, $p = .431$), dominance, ($\beta = -.301$, $p = .219$), extraversion ($\beta = .105$, $p = .652$), methodical ($\beta = -.313$, $p = .087$), openness ($\beta = .100$, $p = .686$), reactivity/undependability ($\beta = .417$, $p = .102$).

7.1.2.3 Total number of puzzle-box solves overall

Overall, chimpanzees exhibited a mean of 35.27 ($SD = 66.27$) successful attempts on the Lazy-Alpha. The model was significant ($R^2 = .399$, $F = 2.519$, $p = .020$). Sex was a significant predictor ($\beta = -.565$, $p = .008$); females ($M = 63.08$, $SD = 81.66$) exhibited more successful attempts than males ($M = 3.82$, $SD = 7.60$). The total time spent observing video demonstrations approached significance ($\beta = .282$, $p = .067$), suggesting a positive trend for time spent watching video demonstrations and puzzle-box success. The number of times individuals observed conspecifics solving the task ($\beta = -.618$, $p = .270$), social group ($\beta = .016$, $p = .911$) nor any personality traits did not significant predict overall success; agreeableness ($\beta = -.318$, $p = .135$), dominance ($\beta = .008$, $p = .970$), extraversion ($\beta = .165$, $p = .430$), methodical ($\beta = .102$, $p = .539$), openness ($\beta = .099$, $p = .658$) and reactivity/undependability ($\beta = .036$, $p = .878$).

7.1.2.4 Number of successes of video-demonstrated methods (Blue Spots and Green Chequered doors)

Overall, chimpanzees solved the video-demonstrated methods on Lazy-Alpha a mean of 21.39 ($SD = 39.84$) times. The model was significant ($R^2 = .402$, $F = 2.556$, $p = .018$). Sex ($\beta = -.523$, $p = .014$)

was a significant predictor; females ($M = 37.5$, $SD = 49.29$) solved the video-demonstrated sides more times than males ($M = 3.17$, $SD = 6.95$). The total time (s) spent watching the video demonstrations positively predicted success with the corresponding methods ($\beta = .311$, $p = .046$), although this was not considered significant under the false discovery rate. Social group ($\beta = -.042$, $p = .763$), agreeableness ($\beta = -.296$, $p = .163$), dominance, ($\beta = -.049$, $p = .819$), extraversion ($\beta = .207$, $p = .321$), methodical ($\beta = .123$, $p = .451$), openness ($\beta = .112$, $p = .613$), reactivity/undependability ($\beta = -.025$, $p = .918$) or the number of times observed a conspecific solve the video-demonstrated methods ($\beta = -.169$, $p = .271$) were not significant predictors.

7.1.2.5 Number of successes of non-video-demonstrated methods (Red Striped and Black Striped doors)

Overall, chimpanzees solved the asocial methods on Lazy-Alpha a mean 14.96 ($SD = 28.81$) times. The model was significant ($R^2 = .406$, $F = 2.598$, $p = .016$). Sex ($\beta = -.642$, $p = .003$) was a significant predictor; females ($M = 27.62$, $SD = 35.16$) solved the non-video-demonstrated sides more times than males ($M = 0.65$, $SD = 1.67$). No other predictor variables were significant; the total time (s) spent watching the video demonstrations ($\beta = -.229$, $p = .139$), social group ($\beta = .032$, $p = .822$), agreeableness ($\beta = -.383$, $p = .071$), dominance, ($\beta = .062$, $p = .765$), extraversion ($\beta = .160$, $p = .442$), methodical ($\beta = .120$, $p = .467$), openness ($\beta = .010$, $p = .962$), reactivity/undependability ($\beta = -.074$, $p = .750$) or the number of times observing conspecifics solve the non-demonstrated methods ($\beta = -.127$, $p = .390$) were not significant predictors.

7.2 Experiment 2

7.2.1 Chimpanzees' first interactions

The binary logistic regression model (observing social demonstration before interaction vs no demonstration) was a significant fit (Nagelkerke's $R^2 = .345$, $p = .010$), and the model correctly

predicted 91% of those that did not observe the social demonstration first, and 43% of those that did not observe the demonstration first. Sex was a significant predictor; males (45%) were more likely to observe a human demonstration first than females (19%), odds ratio = 32.817, $p = .038$. Social group was also a significant predictor (odds ratio = 1.829, $p = .021$), suggesting that groups differed in their propensity to observe the human demonstration or not before puzzle-box interaction. Likewise, the box attraction data was a significant predictor (odds ratio = .966, $p = .038$), suggesting that individuals that showed a greater box attraction score were less likely to observe a demonstration before puzzle-box interaction. No personality trait predicted the propensity to observe the human demonstration before interacting with Chimpbola, but methodical approached significance (odds ratio = 156.064, $p = .068$): agreeableness (odds ratio = 2.221, $p = .483$), dominance (odds ratio = .177, $p = .147$), extraversion (odds ratio = .187, $p = .112$), openness (odds ratio = 1.311, $p = .845$) and reactivity/undependability (odds ratio = 3.704, $p = .229$). Experimenter attraction data was also not a significant predictor (odds ratio = .981, $p = .172$).

7.2.2 Observing human demonstrations over all testing sessions

Overall, chimpanzees observed the human demonstration a mean of 2.89 ($SD = 2.08$) times over the testing sessions. The regression model was not significant ($R^2 = .296$, $F = 1.473$, $p = .191$). Sex approached significance (beta = -.456, $p = .056$), with females ($M = 3.42$, $SD = 2.32$) tending to observe the demonstrations more than males ($M = 2.20$, $SD = 1.51$) over all sessions. Social group (beta = .287, $p = .077$), agreeableness (beta = -.169, $p = .495$), dominance (beta = .315, $p = .175$), extraversion (beta = -.191, $p = .417$), methodical (beta = .067, $p = .715$), openness (beta = .236, $p = .270$), reactivity/undependability (beta = -.157, $p = .543$), box attraction data (beta = -.456, $p = .540$) or experimenter attraction data (beta = -.073, $p = .680$) did not predict the propensity to observe human demonstrations.

7.2.3 Observing conspecifics over all testing sessions

Overall, chimpanzees observed conspecifics interact with the Chimpbola a mean of 7.78 ($SD = 9.80$) times. The regression model was significant ($R^2 = .384$, $F = 2.183$, $p = .043$). Social group was a significant predictor of the propensity to observe conspecifics ($\beta = .485$, $p = .002$), suggesting that groups differed in their rates of observing conspecifics. Sex ($\beta = -.260$, $p = .233$), experimenter attraction data ($\beta = -.283$, $p = .095$), box attraction data ($\beta = .051$, $p = .747$), or personality traits; agreeableness ($\beta = .191$, $p = .411$), dominance ($\beta = .006$, $p = .977$), extraversion ($\beta = .006$, $p = .906$), methodical ($\beta = -.284$, $p = .103$), openness ($\beta = .277$, $p = .355$), reactivity/undependability ($\beta = .017$, $p = .944$) were not significant predictors.

7.2.4 Overall Success

Chimpanzees exhibited a mean of 6.30 ($SD = 8.75$) successful attempts. The regression model approached significance, $R^2 = .418$, $F = 1.976$, $p = .060$. Sex ($\beta = -.609$, $p = .012$) was a significant predictor; females ($M = 9.38$, $SD = 10.15$) were more successful than males ($M = 2.30$, $SD = 3.97$). Social group ($\beta = .129$, $p = .452$), personality ratings; agreeableness ($\beta = -.329$, $p = .169$), dominance ($\beta = .361$, $p = .109$), extraversion ($\beta = .137$, $p = .620$), methodical ($\beta = .313$, $p = .085$), openness ($\beta = -.315$, $p = .210$) reactivity/undependability ($\beta = -.346$, $p = .163$), experimenter ($\beta = .049$, $p = .779$), and box ($\beta = .163$, $p = .312$), attraction data, and number of observations of humans or conspecifics were not significant predictors of overall success on the Chimpbola.