

Durham E-Theses

Assessment of the integration of an organic Rankine cycle for waste heat recovery from bleed air for implementation on board an aircraft

DANIEL RANGEL-MARTINEZ

How to cite:

RANGEL-MARTINEZ, DANIEL (2018) Assessment of the integration of an organic Rankine cycle for waste heat recovery from bleed air for implementation on board an aircraft. Masters thesis, Durham University.

Use policy

The full-text may be used and/or reproduced, and given to third parties in any format or medium, without prior permission or charge, for personal research or study, educational, or not-for-profit purposes provided that:

- a full bibliographic reference is made to the original source
- a <https://etheses.durham.ac.uk/id/eprint/12727/> is made to the metadata record in Durham E-Theses
- the full-text is not changed in any way

The full-text must not be sold in any format or medium without the formal permission of the copyright holders.

Please consult the [full Durham E-Theses policy](#) for further details.

Assessment of the integration of an organic Rankine cycle for waste heat recovery from bleed air for implementation on board an aircraft

Daniel Rangel Martinez

Thesis submitted towards the
Degree of Master in Science



Department of Engineering
Durham University
United Kingdom
November 1, 2017

Declaration

The work in this thesis is based on research carried out in Durham University. No part of this report has been submitted elsewhere for any other degree or qualification and it is all my own work unless referenced to the contrary in the text.

Acknowledgements

My gratitude and recognition to the Consejo Nacional de Ciencia y Tecnologia (CONACyT) and to the Secretaria de Energia (SENER) for this opportunity that let me grow in every aspect of my life. I gave my best to do this work with the intention of giving back the chance granted to me. Thank you to Durham University and the Tecnologico Nacional de Mexico for their efforts to promote and reinforce high level education in Mexico.

To my supervisors: Dr Grant L. Ingram and Professor Simon Hogg; thank you for your dedication to the University; your passion, responsibility, generosity and kindness will always reflect the great persons you are.

CVU: 799383

Scholarship: 460769

Abstract

This project assesses the possibility of putting an organic Rankine cycle on board an aircraft for waste heat recovery using bleed air coming from the engine's compressor as a heat source. Into this task the main subject taken into account was the weight of the system, since this will mean a trade-off between the power generated and the extra weight that is necessary to add.

In recent years, little research on waste heat recovery on aircraft has been done. The main source of heat for these systems comes from the engine and not from the bleed air as in this project but in all cases penalties like changes in engine design, excessive weight from the heat exchangers and a loss in thrust were faced. On the other side, some of these penalties were surpassed by the amount of power that the organic Rankine cycles provided.

To develop this project a model was designed on MATLAB varying the mass flow of the organic fluid to find out for the best arrangement that gives the most power output with the less weight. The model was performed under cruise conditions from an Airbus A320, a single aisle aircraft. The ORC was assessed in two locations; before the entrance of the precooler, a system that cools down the air before going into the pneumatic system, and before the air conditioning (AC) packs. The results show that heat recovery is possible only when the ORC is placed before the precooler but certain conditions need to be met so the energy balances result in positive outcomes. Current techniques were used to estimate the weight of the heat exchangers but improvements of these or availability of new materials in the future will increase the amount of energy that could be saved. The implementation of an ORC using the bleed system gives an option to recover wasted energy from aircraft since the conditions available are suitable for the system.

Contents

• Abstract	4
• Chapter 1: Introduction	7
• Chapter 2: Literature Review	11
○ 2.1: Introduction	11
○ 2.2: Aspects of waste heat recovery systems	13
○ 2.3: Research on waste heat recovery	15
○ 2.4: ORC studies for aircrafts	19
○ 2.5: Environmental Control System	21
○ 2.6: Conclusion	22
• Chapter 3: Fluid and Component's Definition	24
○ 3.1: Introduction	24
○ 3.2: Fluid Definition	25
○ 3.3: Components	27
▪ 3.3.1: Introduction	27
▪ 3.3.2: Heat Exchangers	29
▪ 3.3.3: Pump	30
▪ 3.3.4: Turbo-generator	31
▪ 3.3.5: Additional weight of the piping system and fluid	33
• 3.3.5.1 Pipes	33
• 3.3.5.2 Fluids	35
• Chapter 4: Calculation Method	36
○ 4.1: Introduction	36
○ 4.2: Theoretical basis of the calculation method	39

○ 4.3: Properties	40
○ 4.4: Pressure drop in the heat exchangers	42
○ 4.5: Validation (compare with other test cases)	42
● Chapter 5: Environmental conditions	46
○ 5.1: Introduction	46
○ 5.2: Air conditioning Packs	50
○ 5.3: Precooler	52
○ 5.4: Conditions of the organic fluid	54
● Chapter 6: Results	56
○ 6.1: Introduction	56
○ 6.2: Presentation of key results	57
○ 6.3: Evaluations of the results	71
○ 6.4: Comparison with other ideas	71
● Chapter 7: Conclusions	74
● Appendix	76
● Link	79
● References	80

Chapter 1 Introduction

Alternative and new ways of producing energy are emerging as a consequence of the need of more efficient industrial processes. Solar cells, wind turbines and hydrogen vehicles are examples of how societies are responding to climate change, high prices on electricity, and population growth. In the case of the aerospace industry, engineers keep trying to find ways to increase the engine's efficiency. A novel option to achieve this goal is the recovery of waste heat. The purpose of this work is to calculate and evaluate the energy flows available to realise if it is possible and worth to add the waste heat recovery system. It is the intention of this project to cover the most possible implications of placing the system on board to produce the clearest picture of the situation, validating this through comparison with other related works.

The aerospace industry keeps growing no matter the many economic or social impacts the global society face [1]. This continuous growth comes with its versatility to demands and offers on the global market. But the price for this development is the continuous need of optimization of the engine. Weight is something very important in an aircraft, the lighter the aircraft, the higher number of passenger that can be taken, and with this, the higher revenue could be obtained of each flight. So, at the time of making any change in the engines, weight has to be taken into account as it influences directly in the amount of fuel used for every unit of force generated by the engine (specific fuel consumption).

Parallel to the changes in the engine of an aircraft, fuel energy consumption may be minimized by using the energy that is wasted to the atmosphere. The name of this heat is waste heat, since it is energy not used to produce thrust; it is just released from the engine to

the atmosphere, out of the system. In power plants, a thermodynamic cycle is used to convert heat into electric power; this cycle is the Rankine cycle, which uses the change in phase of water to convert heat into work. The thermodynamic properties of water let it be a compound that can store great amounts of energy during the change of phase. The energy can be recovered from heat sources with high temperatures ($T > 500^{\circ}\text{C}$) and successfully converted into electrical, mechanical or other type of power. For sources of heat where the temperature is not great enough to change the phase of water, the Rankine cycle could be still used if, instead of water, an organic fluid with low boiling point is used. These organic fluids, also called refrigerants, are used in air conditioning systems to “collect” the heat from a volume of air and then release it to a different one (a heat exchanger). The thermodynamic properties of these organic fluids make them perfect for low quality heat sources (temperature $\leq 100^{\circ}\text{C}$). A Rankine cycle using this type of fluid to collect heat is called Organic Rankine Cycle (ORC) and its use is increasing as new developments in the components are achieved, i.e. better materials, comprehension on fluid dynamics and on the organic fluids.

The objective of this project is to model an ORC that can be placed on board an aircraft and produce enough power output to compensate the power needed to carry it and, crossing this boundary, produce extra free energy for being used in the aircraft. The source of heat energy will be the bleed air system which uses air coming from the engine for many purposes and which will be explained in detail later.

Since the application of ORC systems on board has been barely explored, not too much information was found about it, so experience on the field wasn't a factor that could give important contributions to this project; nevertheless, the few publications around it were very useful for comparing and validating results. The airplane from which the conditions and characteristics were taken for this project was an Airbus A320.

The obtained results answered the question that if it was convenient and worth to put an ORC on board an aircraft, and the answer is yes, it is, but the source of heat has to satisfy many conditions to be able to save energy. From the many combinations of available circumstances, a production of 10.7 kW of energy was demonstrated to be possible. The heat source must be the bleed air coming directly from one of the high stages of the compressor and a high mass flow in the heat sink. The designs are technically feasible since they were achieved with standard design techniques and available materials but since this is a new application for the components, the system is not available to be purchased in the markets so aspects concerning with problems in construction of any of the components of the system couldn't be seen in detail and may be taken into account for future research.

The assessment of the system was done, as said before, in two locations of the aircraft and in both a wide spectre of results is obtained, in the graphs presented in Chapter 6 a predictable behaviour can be seen and analysed. Further research should focus on finding the maximum power output with the minimum impact to the engine's function of the ORC since it is proven in this work that the available circumstances are adequate run an ORC.

The explanation of the project and the results obtained will be developed in the next chapters. It is intended, first, to make clear through the literature review the actual state of the art of the situation concerning actual and past attempts for recovering waste heat from aircraft, in the terms of purpose, motivations and results and an impartial judgement of the research. The components and the organic fluid used will be described in Chapter 3, so the reader can have a clear idea of the configuration of the ORC, also an important consideration of two other possible configurations with superheating will be described and evaluated, since they would produce more power output; this situation is evaluated and validated in the Results' Chapter. The weight of the system, along with the production of energy from the system are the two major results from each system modelled. The main and heaviest

components are the heat exchangers; the calculation method of the weights of these components is described in Chapter 4 along with the database of properties used in this work. A validation of both processes is carried out using as comparison the results of related projects. The environmental conditions with which the system will work are detailed in chapter 5, both situations (ORC before the AC pack and ORC before precooler) are described and settled, along with the parameters used in the system. With the detailed explanation of the circumstances and limitations that govern the function of the ORC, the information given in the section of results in Chapter 6 provides a picture of the conditions needed to find a feasible ORC on board.

Chapter 2 Literature review

2.1 Introduction

A change in sources of energy and an increase of efficiency in every industry is not only an option but a need. Having reached the crude oil production peak in almost all OPEC countries [2], climate change and a continuous growth in demand of energy are some of the factors that are moving the global society into the use and development of renewable sources of energy. The aviation industry is not the exception and, expecting to need by 2035 twice the amount of aircraft that it has today [1], it is taking action to develop new technologies and tools for a future with less fossil fuel dependency.

Although kerosene cannot be easily replaced due to its high heating value (43 MJ/kg), the aviation industry is looking for the integration of new technologies to aircraft to get additional energy from renewable sources. Solar cells are now seen as an option to provide clean electrical power for avionics, lights and televisions on board, by covering the wings and fuselage with them. Fuel cells can also provide electricity and, as a by-product of the reaction, clean water that could be used in toilets and sinks. Some possible fuels that can be used in a today's engine could be hydrogen and green fuels (made by algae); but, in the case of hydrogen, storage is a problem (hydrogen has a lower energy density compared to kerosene) so a redesign of some part of an aircraft must be done [3]. The algae are capable of producing kerosene-like biofuel; this option seems to be a promising for helping aviation industry to cover future demand on fuel but, today, biofuels are not yet an option because of the huge pressure and temperatures needed in the process [4].

The possibility of extracting more energy from the fuel is a big concern for engineers, it is estimated that only 12-25% of the fuel energy is converted into useful work [5]. Waste heat is one of the major issues in all industries; in aircrafts it is estimated that 50-55% of the

total fuel energy becomes waste heat [6]. Many research on this topic have been done. The combined-cycle engine and the organic Rankine cycle (ORC) are possible solutions to this problem by recovering part of the energy lost as heat.

Putting extra weight in an aircraft in exchange of extra energy is a trade that has to be evaluated (weight is sometimes more important than efficiency), this report aims to define the feasibility of a low weight ORC in an aircraft to provide additional energy. There has not been too much research about the analysis of this idea or the consequences of its implementation on aircrafts. Rotorcrafts have had few research and vehicle industry has developed prototypes that, successfully, raised the thermal efficiency of the engine by 3.8% [7]. Absence of practical uses of a waste heat recovery system on aircrafts must be seen as a new possible way to get more power from jet fuel. Some points intended to be explained in this literature review are:

- Aspects of Waste heat recovery
- Current research about waste hear recovery systems
- The Organic Rankine Cycle on aircraft

Although attention is greatly focused on new technologies, waste heat recovery systems are now emerging in interest, partly because of the large quantity of energy available. Barriers such as low range temperatures, changes in engine configuration and weight limitations will be contemplated in this research for the development of a low weight ORC. People that have done studies on waste heat recovery systems on aircraft [6, 8, 15] are optimistic about the implementation of a waste heat recovery system on board, arguing that there is an opportunity to raise the overall efficiency of the aircraft but an inconvenience relies in the need of the radical change of the configuration of the engine. In view of this fact, looking for other sources of waste heat rather than the engine must be taken into account, for example the environmental control system (ECS), the engines cowl and even the heat

released from passengers can be harvested and used to produce electricity [8]. The ORC can take energy from low range temperature heat sources by using organic fluids with low boiling points. Thus, this research also aims to answer if the integration of a waste heat recovery system on board of low weight without encroaching on the engine's structure and generating extra power may be technically advantageous through an ORC.

2.2 Aspects of waste heat recovery systems

The facts that no process can convert, entirely, an amount of heat into work and that efficiency of a process will never be 100% are stated in the 2nd law of thermodynamics. This energy that is not used to produce work is dissipated as heat at various temperatures, levels and through different streams [9]. On aircraft, half of the fuel energy is lost in this way [6]. Nevertheless these sources of waste heat are ubiquitous; it has to be stated that from this lost energy, only a fraction can be exploited for producing mechanical work (available exergy) or other purposes, for example, just about 30% of the total waste heat can be actually converted into useful work [9]. Today's aviation industry is more interested than ever before because the future demand of aircraft cannot be covered with the actual types [1], new technologies are needed and the maximum exploitation of the fuel energy is necessary. The areas where unused exergy exists and that can be used for getting additional power can be detected with the development of new tools like an exergy mapping [10].

As said before, the heat energy can be converted into mechanical or electrical power. This conversion will depend on many characteristics of the heat source. If, for example, in an air conditioning system, an external hose wall is two or three degrees above the ambient temperature, it would be a waste of money and weight to recover that little amount of energy, nevertheless, this power leak will be an irreversibility of the process that, along with other similar leaks will diminish the thermal efficiency. This type of heat is called waste heat and it is *the unused heat energy generated as a by-product of energy conversion processes* [11],

generated as a natural consequence on any non-adiabatic process, as described in the laws of thermodynamics. The quality of the waste heat is a characteristic used to find out the best regeneration process for the heat source and is determined by the range temperature it handles. Table 2.1 shows the range temperatures of heat sources according to Auld [11]. The third column (heat sink) makes reference to the temperature of the place where the heat exits the system. Example of these concepts is a refrigeration system; heat enters to it (heat source) through the evaporator and comes out (heat sink) through the condenser.

Table 2-1: Waste heat quality categories defined by Auld [11].

Quality category	Heat source	Heat sink
High	>500 C	> 250 C
Medium	250-500 C	150-250 C
Low	< 250 C	< 150 C

The vast majority of available waste heat is of low quality [11]. It is difficult to use it in the industrial sector, either economically or technically, due to its low exergy [12] and because steam turbines need higher temperatures to produce work from this sources. This low quality waste heat can be used by an ORC which uses low boiling point organic fluid like pentane, toluene or hexane as working fluid. The ORC has already been used as waste heat recovery system in automobiles, taking advantage of the main engine exhaust gases [13].

In aviation industry no waste heat recovery (WHR) system has been added to an aircraft, some reasons include lack of interest, variation in flight conditions and the strict requirements that should be covered by companies before releasing any new engine. Actual research on waste heat recovery on aircrafts suggest adding the WHR system to future engines [15, 8] and some propose to make changes in current engines [6] but changing the actual design is an obstacle because that means expenses in research, tests and certifications. However WHR systems have been studied to be added to an aircraft but not all the options have been analysed, as said before, many other sources of heat should be taken into account,

for example the air that enters to the air conditioning pack has a temperature of 180 °C, this air is cooled with ram air from the outside until its temperature is of about 22 °C, the heat extracted is released to the atmosphere instead of being used for producing additional power [14].

2.3 Research on waste heat recovery

Pasini et al. [15] analyzed the possibilities that heat recovery would bring to the overall efficiency of an aircraft engine. A waste heat recovery system is modeled in a jet engine and a turbo propeller engine. They evaluated their project taking into account the nozzle works in off design conditions and contemplated the possibilities of heat recovery in many parts of the engine and said that the most suitable for propulsion applications seems to be that shown in figure 2-1. The heat discharged influences strongly in the performance of the system and problems like engine configuration and specific limitations like weight, overall dimensions and maximum reliability don't let this opportunity to be taken[15]. The authors emphasize that it is possible to take advantage of waste heat but that considerable problems need to be attended.

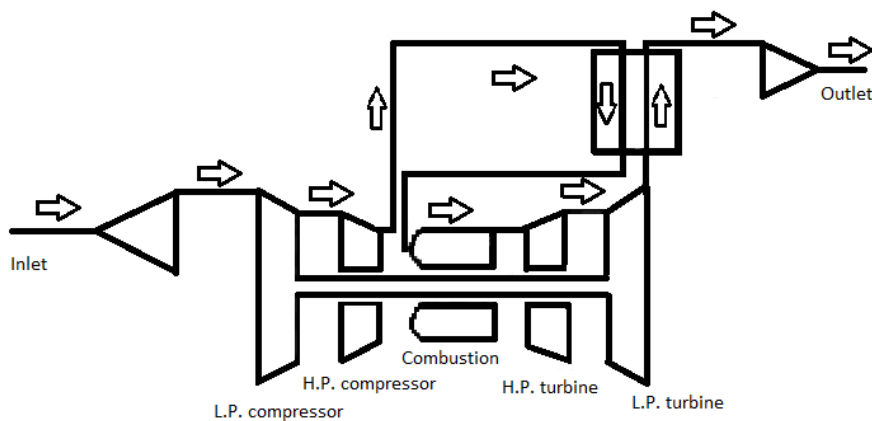

Figure 2-1: Scheme from Pasini of a turbojet engine with regeneration [15].

The heat, extracted from the nozzle is used to preheat the air that enters into the combustion chamber, this heat extraction influences the enthalpy drop available in the exhaust nozzle and hence the discharge velocity [15]. This is the principal consequence of

regeneration in this specific area of the engine: the reduction of heat in the exhaust and in the propulsion efficiency.

In the same study evaluations of whether the heat recovery can have positive impact in a turboprop; a turbofan and a turbojet were modelled with a numerical thermodynamic code developed by them. Different conditions were analyzed to cover the major amount of possible sources of energy for WHR. Turbojet and turboprop details are omitted and only turbofan results will be commented.

The turbofan engine is of great interest because the very large fraction of the thrust is provided by the cold flow, while the gas generator provides the required power [15]. By this assumption, the authors of the study concluded that the enthalpy level before the exhaust nozzle of the gas generator can be lowered without losing a great amount of thrust [15]. Results of calculations from evaluating a heat recovery system make evident that an increase of thermal efficiency of about 4% was attainable when heat recovery was done (when the efficiency of the regeneration was 0.5). An increase of about 10% was achieved if the efficiency was of 0.7. According to the numerical simulations of their work, the best place for heat recovery is from the hot gas before entering the nozzle; the best performance is obtained but the problem of introduction a heat exchanger suitable to meet the requirements of the engine prevails.

The work made by De Serve et al. [6] is a WHR system based on a closed thermodynamic bottoming cycle that uses supercritical carbon dioxide as working fluid because this compound can achieve very high power density levels. This combined cycle engine (CCE) has a 20% lower SFC compared to a conventional turbofan if pressure drops in heat exchanger were neglected. The same problems like weight of the additional equipment, space constraints and the lack of proper heat exchange technology for such purpose, limit the exploitation of the waste heat from the engine and explain why engine efficiency is targeted

on improving on areas like inlet temperature rise, larger overall pressure ratio and the increase of turbo machines performance.

The study that de Servi et Al. [6] made use of a super critical CO₂ power cycle concept to examine the reliability from different combined cycle configurations recovering the heat from the gas turbine exhaust, the engine in which the system is placed is a turbofan engine GE 90-94B. The WHR system is inserted in two parts: the main heat exchanger (MHE) after the low pressure turbine, in the core nozzle, and the cooler in the fan duct. Figure 2-2 shows the combined cycle diagram. The authors make some assumptions before making the calculations: 1. - the engine operates in cruise conditions, 2. – the effect of weight and size of the equipment are neglected, 3. -the effect of the heat exchanger are modeled by means of NTU and ΔP on the hot and cold side, 4. -the mechanical power obtained from the CO₂ WHR unit is converted into thrust with an efficiency of 90%.

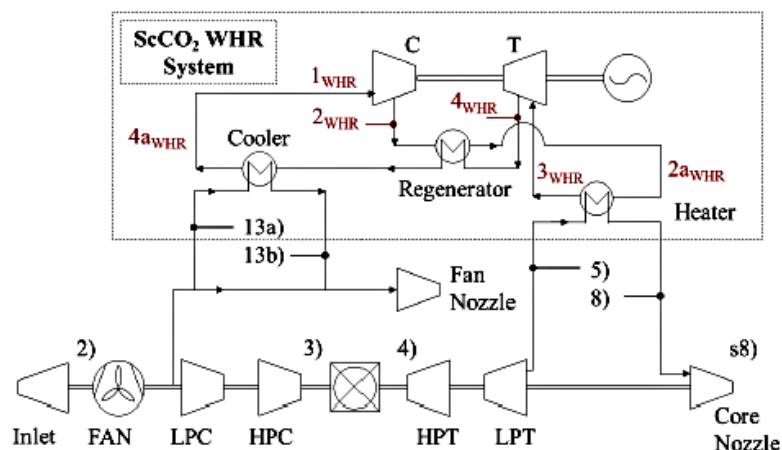

Figure 2-2: Simplified process diagram of the CCE [6].

The reason why the WHR system is added on the GE90-94B turbine engine is to try the model using real established data. Figure 2-3 shows the schematic of the modified GE90-94B. The location of the CO₂ WHR system can be seen clearly. The heat exchanger is

assumed to be in the engine core nozzle and in Figure 2-3 appears as MHE. The cooler is positioned in the fan duct. Also a section of the cooler is shown.

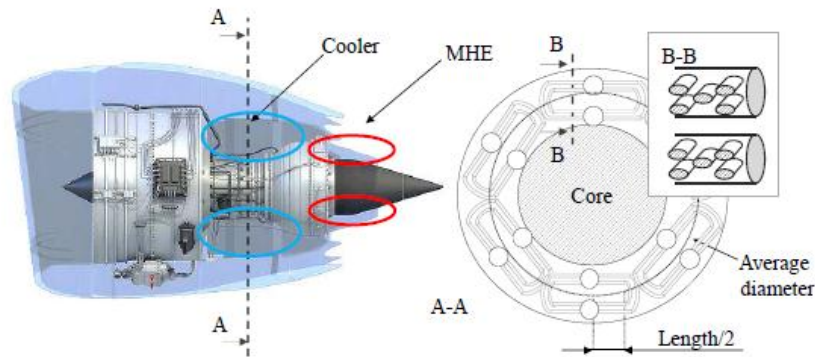

Figure 2-3: Modified GE90-94B turbofan engine with WHR system added and a detail of the cooler [6].

The calculations of the author and the comparison of the combined cycle engine with an intercooled regenerative engine, another type of WHR system, leads to the conclusion that the CCE shows a better thermodynamic quality but the optimal thermodynamic performance is expected to occur with higher OPR values, even higher than those of current turbofan engines. The estimated SFC reduction of the CCE was of 2.8% but it is insufficient if the weight of the unit, about 3 tons per aircraft engine is factored [6]. This problem is due to the actual configuration of the engine and the lack of technology for this application. The reader must take into account that this is an addition to an actual existing engine design and that integration from the beginning of the design of it may bring more benefits. The component that brings more disadvantages is the cooler because of its volume and weight, so the author recommends for future research the development of innovative and specialized heat exchangers. Considering the high pressures and temperatures in the fluids the need of such a big heat exchanger is understandable, but the implementation of this system, although it will produce a high amount of energy and the calculations show that it will increase the sfc of the

engine, it is an option that sacrifices a lot of volume and weight from the aircraft that may be used for other purposes.

2.4 ORC studies for aircrafts

In another study [8] made by Perullo and Mavris, an organic Rankine cycle (ORC) is integrated to an engine for power generation. The authors talk about the problem that as bypass ratios continue to grow and engine cores become more efficient, the engine fan diameter is increased and the core size is diminished and as a consequence, pneumatic off-take require a larger percentage of the core flow leading to larger performance penalties [8]. They try to give a solution to this problem by changing the pneumatic off-take for an electrical one, and use the power generated to drive external air to the ECS. With this idea of a no-bleed aircraft, performance penalties for shrinking cores and increased fan diameter are supposed to be eliminated and in calculations and modelling they have demonstrated that a rise in efficiency from 0.9% to 2.5% is possible. The no bleed system had been also applied by Boeing; the source of energy is not an ORC but a generator that works with energy taken from the APU and the engines. This application leads to a fuel saving of 3% [16], which explains why Perullo and Mavris put together this idea with an ORC; instead of extracting energy from the fuel, the waste heat could supply the energy needed.

The use of an ORC is because the range temperature available is of low quality. The WHR system is placed in the core jet exhaust of a turbofan engine. Conversely to land ORC systems, used in steam power plants for example, an on-board ORC would suppose operating conditions that may vary continuously in the course of every few hours in external pressure and temperatures. The amount of heat extracted from the engine should be taken in care in order to prevent considerable reductions of thrust. The system is distributed in the nozzle, the nose cowl and the Pylon. It uses as working fluid, R245fa after it showed the highest thermal efficiency across a wide range of operating pressures. It was modelled using MathCAD 2001

software and the purpose of the model was to determine if sufficient energy could be extracted from the exhaust gases to power a 270 horsepower motor [8]. Figure 2-4 shows the ORC schematics.

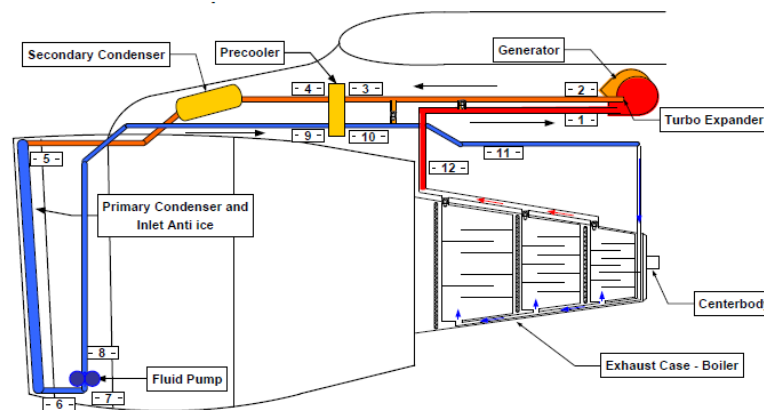

Figure 1: ORC Cycle Schematic

Figure 2-4: ORC system integrated into a CFM56-7B turbofan engine [8]

The model was integrated on a CFM56-7B configuration and cruise conditions were used in it. Some important assumptions were made: 1. -not analysing the system with take-off conditions, since the working fluid dissociates at high temperatures; 2. - the heat is extracted from the core exhaust flow before it is expanded in the nozzle (because the code used to analyse the model did not allow to do it after). The weight assumed for the ORC was of 430 kilograms and was used to calculate the fuel burn reduction, which was of 0.9%. The TSFC reduced its value in 2% compared to the engine alone. An assumption that the ORC could provide more power that is necessary to drive the ECS air compressor was made; in that case the TSFC was reduced in 2.2%. The authors concluded that an ORC WHR system can provide retrofitted onto an existing engine and that can be used to provide enough power to a compressor driving air to the ECS. They suggested for future research that the design of the system should be reconfigured to get the best results of fuel burn, and to take into account the need of an electric starting mechanism if the bleed system was removed. Also of interest is

the option of using the engine cowl or the anti-icing system in the wings as the condenser of the ORC system.

2.5 Environmental Control System

The air in the cabin comes from the outside and is treated before getting into the cabin, the thermodynamic characteristics and chemical composition of the air are controlled before delivered, after it circulates in the cabin, part of this air is released to the atmosphere and the other part is recirculated. In the first stage of this process, cold air from the outside at about $-50\text{ }^{\circ}\text{C}$ and 20 kPa [17] enters into the engine, in the case of the CFM56B, the engine used in this work, about 17% of the air gets into the core for combustion (primary mass flow) and the other 83% travels outside the core for cooling (secondary mass flow) [18]. From the primary flow, about 7-12% (depending on the external conditions) of the total is used for the pneumatic system [19], which includes the Environmental control system (ECS). After this air is collected from the engine, it has a temperature of 450°C and a pressure of 1020 kPa [18] then it is cooled down to 200°C using air coming from the fan and the pressure is regulated with valves to 24 kPa [17]. From this point the air has the needed conditions to get into the pneumatic system. Here, the air flow splits to the many systems that need the fluid including the ECS. Two air conditioning packs, one for each engine, treat the air to produce a continuous flow of 1 kg/s , $22\pm 2^{\circ}\text{C}$ and 100 kPa to deliver into the cabin [14]. Chemical and physical properties are also controlled in this point, the humidity is less than 5% and the concentration of ozone is less than 0.25 ppm [17]. After entering to the cabin, about 50% of the air is recirculated and used again, the rest is expelled outside [17]. The ECS is a system that works with basic principles, the purpose of it is to receive, treat and deliver air coming from the engines to the cabin, using ram air, filters and heat exchangers to reach the conditions needed. The available conditions and circumstances in which the ECS work match with the needs of a basic ORC, the assessment of these aspects in this location and in

between the precooler and the engine for getting work output from the wasted heat is the purpose of this work.

2.6 Conclusion

The amount of wasted heat available in aircraft for recovery must be taken into consideration nowadays, since it is a potential source of energy that is not exploited properly. The growth of the aerospace industry along with the environmental compromises that the global society face for the future are the main reasons to keep finding new sources of energy, in this labour of application of new energies and the increase of the efficiency of the engines and different parts of aircraft, the recovery of wasted heat has the potential of playing a serious role. As seen in the works showed before: the combined cycle engine (CCE), the system from Perullo [8] and the work from Pasini [15] are systems that take advantage from the high pressures and temperatures present in the engine and increase the overall efficiency of the engine and thus, decrease the specific fuel consumption but the changes in architecture and the added volumes imply deep changes in the engine which may be not the easiest manner to recover the heat available.

But sources of waste heat are not only available in the engine, although they are the highest amounts of energy, the bleed system and the process to control the thermodynamic characteristics of the air represent an opportunity of recovering wasted heat. Air to air heat exchangers are used to extract the heat, once provided by the fuel, from the air going into the cabin; this heat is then release to the atmosphere through an air flow, coming from the outside, gathering the heat energy in the heat exchangers and then returned again to the outside. This process happens twice, first in the precooler, which treats the air coming from the engine to be delivered into the pneumatic system and secondly in the AC packs, which cools down the air to deliver it into the cabin.

With the addition of the ORC system, the impact into the aircraft is less and thus the amount of energy is minor as well but this situation opens another option to be considered for recovering wasted energy. With the addition of the ORC before (or even instead) the precooler and the AC Packs there is no invasion in the engines with the addition of extra weight or volumes and the process is still the same, also there are no changes in the conditions or parameters with which the pneumatic system works, the extra energy in the bleed system that is not used anymore is from where the advantage is taken and the conditions of the air are still met as if there was no ORC.

Chapter 3 Fluid and Component's Definition

3.1 Introduction

The selection of the type of fluid and components is critical to get the most of the available energy with an ORC. In the case of the fluid, there are two limits in pressure and temperature that have to be taken into account. When coming out of the condenser, the minimum pressure and temperature in the system are reached and when coming out of the evaporator the organic fluid has the highest pressure and temperature in the system. These two limits have to be taken into account for defining which organic fluid will be selected because if the temperature is too high the chemical bonds of the molecules can break and the compound becomes a mixture of different molecules of different lengths (decomposition); if the temperature, on the other side, is too low, freezing may occur or less efficiency is obtained. Yu et Al. [20] show the maximum and minimum optimal temperatures and pressures for work with each refrigerant. Along with this, some past experience from recent research, particularly the one from Perullo [8] was taken into account for selecting R245fa as the organic fluid. The decision of which fluid was the best option was taken from the temperatures available for the heat exchange and from other research made for similar purposes.

The components for integrating the ORC were selected taking into account that they should be light in weight; compact heat exchangers, a pump designed for aircraft and a turbo generator made with lightweight materials were searched for being part of the system. The heat exchangers, being the heaviest components of the system, were designed as compact heat exchangers using the method from Kays and London [21]. The design always changes depending in the mass flow of the organic fluid so there were unique heat exchangers for every mass flow specification. In the case of the pump and the turbo generator, there was no

need to design them because they are available in the market; the selection of them was based on the needs of the system at the highest pressure. The selection of the components is crucial since from them the weight of the system is derived. The heat exchangers needed to be designed since their volume changes with the mass flow available and in the case of the pump and the turbo generator, they were selected from catalogues available in the market. With these criteria it was attempted to produce the lightest possible ORC system for every given mass flow using standard design components and weights leading to off the shelf heat exchangers. The selection of the organic fluid aims to recover most of the available energy from the heat source based on the limitations of the system and of the organic fluid.

3.2 Fluid Definition

An organic fluid is a compound consisting mainly (but not only) of carbon and hydrogen; some of them have very low boiling points and are used as refrigerants in air conditioning systems. These fluids are also useful for ORC systems because they can collect low quality heat and let it be used for producing mechanical work. The working fluid selection is an important aspect to consider in an organic Rankine Cycle. There are many aspects that are affected by the working fluid: efficiency of the system, design and size of the system components [1], power output and amount of waste heat recovered. In this project the principal characteristics to take into account for the organic fluid selection are listed below:

1. - Low weight system required.
2. - Rate temperature of the heat source: 200-450 °C.
3. – Lowest temperature in the system: Ram air: -50 °C

Other research involving ORC systems on board have selected R245fa as working fluid. It is an isentropic fluid that gives a high work output for temperatures higher than 160°C and it is recommended for waste heat recovery [1]. It was selected in this project as

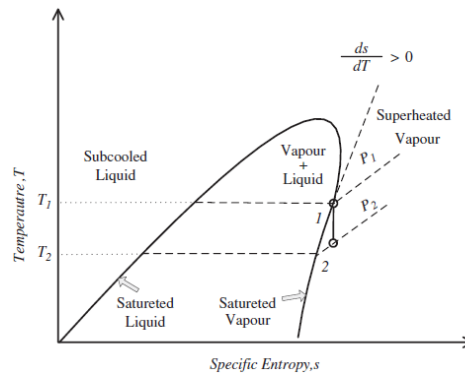

Figure 3-3: Saturation curve of a dry fluid [22].

3.3 Components

3.3.1 Introduction

Many configurations of the ORC are possible depending on the needs and conditions of the situation where it is meant to work. The weight of the ORC will define the amount of extra fuel that needs to be burned, since the weight of the aircraft will increase due to the addition of the ORC. Special attention must be paid to the materials and type of components that will be used in the design of the heat engine. Light weight components and materials were taken into account for estimating the total weight of the system. Every unit of weight in an aircraft increases the amount of fuel burned per second, so it is important to find the maximum generation of energy with the less consumption of fuel and for this reason, the selection, number and type of design of the components is crucial.

Superheating and regeneration are options that can let the overall efficiency rise considerably, and with this, the amount of work output produced by the ORC but there is an important condition to take into consideration: having these two options integrated into the ORC will increase the total weight of it. Figure 3-4 shows the basic components of the Rankine Cycle, figures 3-5 and 3-6 show other possible configurations for increasing the efficiency of the cycle but these add one more heat exchanger, in the second figure and two in the third one, as a consequence, the weight will increase and therefore the energy charge that has to be paid.

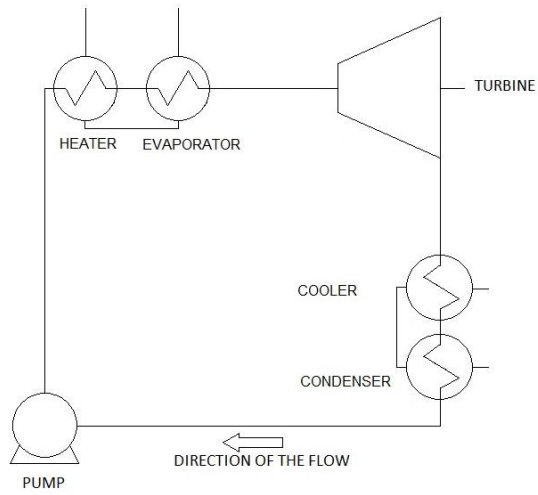

Figure 3-4: Elemental Rankine cycle.

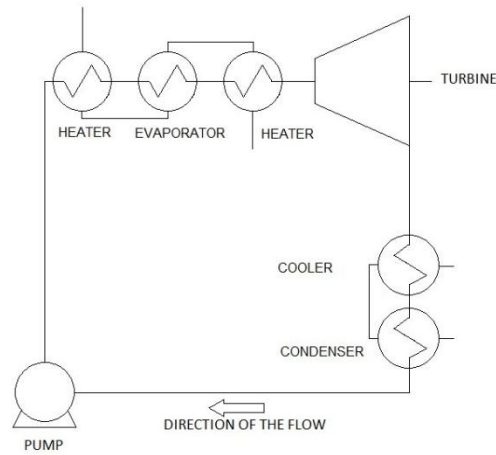

Figure 3-5: Rankine cycle with super heater.

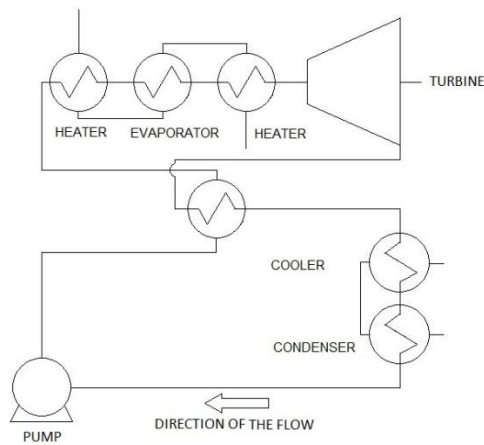

Figure 3-6: Rankine cycle with super heater and regenerator.

3.3.2 Heat Exchangers

The heat exchangers are the heaviest components of the ORC and the increase of the overall weight depends strongly on the mass of these components which depends on the mass flow of the organic fluid, on chapter 6 is presented a graph that shows how the mass of the heat exchangers grows against the growth of the mass flow; compact heat exchangers were designed using the calculation methods from Kays and London [21]. Two two-phase-change heat exchangers (evaporator and condenser) and two single-phase heat exchangers were used. Literature recommends, for each kind, a different arrangement due to the conditions of each process. When the circumstances involve a change in phase the finned tube (figure 3-7) is the option that should be taken, inside the tubes goes the fluid that will be evaporated or condensed and through the fins, the fluid used to evaporate or condense. If the heat transfer is from gas to gas then a plate fin type heat exchanger (figure 3-7) is recommended due to the high areas available which are needed by low density fluids to transmit effectively their heat energy. The method suggested by Kays and London [21] to design a compact heat exchanger gives the amount of area needed on each side. The inputs in the method are the amount of heat that is needed to be exchanged; the mass flow of each fluid, geometric properties of the type of heat exchanger and thermodynamic properties of the fluids: the method will be explained in detail in next chapter. With the areas defined, and considering the geometric characteristics of each side, the volume of the heat exchanger can be calculated. In some cases the volumes will result in impractical measures difficult to achieve. The weight of the heat exchangers is calculated by multiplying the area of each side by the thickness of the material and then this volume is multiplied by the density of the material used for building the heat exchanger (aluminium in all the cases). Since the aim of this project is to calculate the weight of the component, the situation regarding the feasibility of them being easy or difficult to build was not attended. The weight of the heat exchangers depends strongly on the

area needed, the type of material and the type of geometry; the method used allows to take into account all these characteristics so the final volume obtain is the most accurate possible.

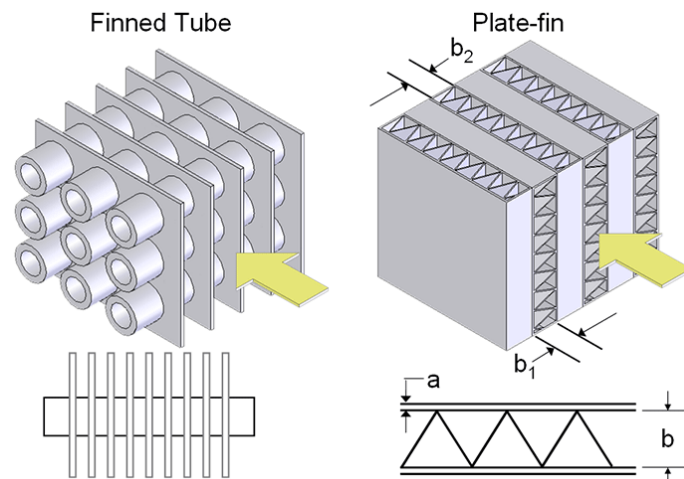

Figure 3-7: Finned tube and plate fin geometry [23].

3.3.3 Pump

The pump, beyond being in charge of circulate the fluid in the system, defines the pressure at which the fluid will enter the evaporator (see fig. 3.4) and this pressure is correlated with other thermodynamic properties (evap. temperature, enthalpy and entropy) (see fig. 3-1). A pump that matches the specifications of pressure and mass flow of the conditions on this project was searched and the weight of it was added to the total weight of the system. There is a great number of pumps, meeting many purposes and capacities, and their features can be easily find on the webpages of many companies. Contrary to the method for finding the weight of the heat exchangers, the characteristics of the pump can be added from a pump that satisfies the needs of the ORC; this saved time on the design of the system. For the search of the pump the top criteria was to find a pump manufactured for aircrafts, so the weight was the lowest possible, also that the pressure rise was above the one stated in the environmental conditions of this project (Chapter 5 in section 5.4), and that works with the refrigerant R245fa. A light weight pump, from Cascon Inc. [24], used for another type of refrigerant (R134a) which has similar characteristics to the R245fa was used; the performance data of the pump was considered when choosing it. Characteristics like pressure,

mass flow capacity and temperature range were included as well as measures that should match with the ones of this project. Some important specifications of the pump are listed in the table 3-1. The weight of this pump was compared with others with similar characteristics and purposes, a similar weight in all the cases was found. Although the parameters of this pump are not exactly the ones of the project are very close to them, other pumps with different matching points with the conditions of this project also showed similar characteristics. The pump selected from an online catalogue is acceptable for this project; it meets the needs and the fact that other similar pumps used for the same purpose have parallel characteristics supports this choice.

Table 3-1: Pump specifications [24].

R134a Liquid Refrigerant Pump for 2-phase Liquid System	
Fluid	R-134A
Flow Rate	50 – 600 LPH
Temperature Range	-29 C to +65 C
Pressure Rise	380 kPa
Burst Pressure	10690 kPa
Mass	2.5 kg

3.3.4 Turbo-generator

The turbine and generator are key components of the system and as seen in the literature review, the amount of research made for ORC on board an aircraft for producing energy is limited; this situation describes the lack of options when choosing the components of the system in this work. The turbine is a complex, high precision element that needs to be designed for each set of conditions in the ORC. Depending on the specifications of the system, a particular turbine is designed; this process is highly complicated and takes time. The type of turbines available in the market are intended for big production of energy (1-15 MW in the case of the smallest ones) compared to the highest work output that the ORC developed in this work can give (10.7 kW). A diesel engine is the source of the mechanical energy and the purpose of

them is to produce energy for houses, construction works and portable equipment. Coupled to this, these turbo generators are considered heavy because they are designed for land based works; there is no limitation in the type or quantity of materials, in consequence: any limitation of the weight. These generators are sold in one piece, and the specifications of them correspond to the compound system. These circumstances complicated the task of looking for a turbo-generator. The weight of the turbine was approximated in a similar way to the one used in the pump. On the other side, the weight, materials and efficiency were not available for the generator. A first approximation could be made of an electric motor which in theory works the same as a generator in the opposite way. A comparison of this weight with one obtained from rough calculations, of a four poles, permanent magnet generator, show agreement between both equipment. A weight of eleven kilograms was found online [25] and compared with the calculations; table 3-2 shows the summary. The calculations by the author considered mass dimensions of active materials (not including casing or other components that do not make any work in the electric motor) belong to a four pole permanent magnet generator with merge airgap (1 mm) and carbon fibre bandage. From this comparison an estimation of the mass of the generator was established. In every single calculation made, whatever the energy output was, a mass of 10 kilograms corresponding to the generator was added.

Table 3-2: Estimations of generator weight.

Object	Weight	Comments
Weight of an electric motor found online.	11 kg	3,600 RPM, 8.5 kW-14 kW, 90% efficiency
Calculations for a generator by the author.	7 kg	10,000 RPM, 16kW, 96% efficiency.
Mass added to every calculation.	10 kg	No comments.

The turbine, as said before is a component that changes in its design for every combination of conditions of the ORC. The mass of the turbine was estimated from the work

of Kang [26], the turbine in this work was designed for an ORC with R245fa as working fluid and an approximate power output of 30 kW. This turbine is made with aluminium and it has a diameter of 125 mm of diameter and is about 50 mm in height. The mass of this turbine is less than 0.8 kg so for this work a mass of 1 kg was added to every calculation to integrate the mass of the turbine into the total mass of the ORC.

3.3.5 Additional weight of the piping system

3.3.5.1 Pipes

In the sections before, the weight of the components is specified and integrated to obtain the total weight of the system, the additional weight of the tubes is taken into account but is considered as constant since there is no simple way to measure the influence of mass flow with its growth, also, the available volume of space where the ORC will be located in the aircraft is necessary for this. The pipes are made of Aluminium T3 2024, and are 38 mm outer diameter and 36.32 mm inner diameter; it was considered that three meters are enough to connect the components since there is no past experience for this part of the project there could not be any validation or comparison through other works. From the past information an estimate of 4.5 kg is added in every calculation of the total weight. As a consequence of the addition of these pipes, there will be losses in pressure. Aluminium presents a low surface roughness (0.0014 mm) [43] and also a low weight. There is a loss in pressure due to the interaction between the walls and the fluid inside it, in this case, since the roughness of the metal is small, then the pressure drop is expected to be low. Since the pipes are distributed along the system, in any case there would not be a pipe longer than 0.5 m so the reduction in pressure would not be relevant. To sustain this consideration, a single calculation was done in one of the areas of the system with highest Reynolds number and velocity, equation 4.1 was used to find the pressure drop:

$$\Delta P = \lambda \frac{L}{D} \frac{\rho}{2} \omega^2 \quad 4.1$$

Where λ is the friction factor, found with the Moody chart (fig.3-8), using the Reynolds number of the fluid, L and D are the length and diameter of the pipe respectively. ρ refers to the density of the fluid and ω the velocity of the fluid inside the pipe. The description of the conditions is shown on table 4-1

Table 3-3: Characteristics of the fluid to be evaluated

Parameter	Value/Description
Fluid and phase	R245fa condensed liquid before entering the pump
Mass flow	2.5 kg/s
Reynolds number	222,693.45
Velocity	1.804 m/s
Density	1337.8 kg/m ³
Pressure	150 kPa
Temperature	298.41 K
Internal Diameter of the pipe	0.036 m
Length of the pipe	0.5 m
Estimated pressure drop	0.67 kPa or 0.45%

As can be noted in the table above the pressure drop is less than one percent in the case where we have a high mass flow. The conditions are referred to the condensed liquid coming out from the cooler and entering the pump. Since this project focuses only on the theoretical function of the system and no experimentation was made, the pressure drop in the pipes is not considered as an important reducer of the overall pressure of the system; the influence of folds, valves and gauges were not considered as well.

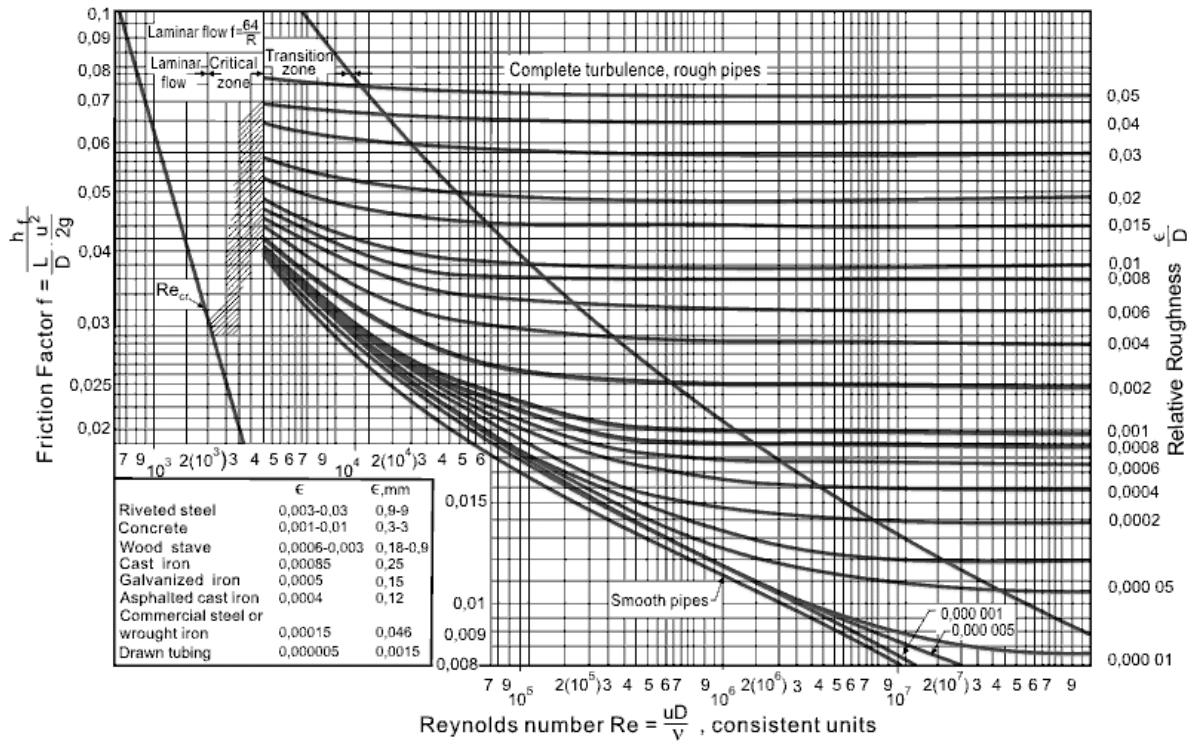

Figure 3-8: Moody chart to find friction coefficient [44]

3.3.5.2 Fluids

The necessary characteristics of the geometry for calculating the volume and thus the mass of the organic fluid (R245fa) and the air were not available in the literature, it focuses in the design and sizing of the heat exchanger. It was intended to add the exact weights of the tubes and the fluids to the total weight of the system but only the extra weight of pipes could be calculated accurately; the estimation of how much fluid (in kg) is in the heat exchangers was done through a simple calculation using the free flow area A_o . This parameter is the frontal area in the heat exchanger that the fluid needs to get inside it and does not take into account the material of the heat exchanger. This free frontal area is then multiplied by the depth of that heat exchanger and thus a volume is obtained. This volume is then multiplied by the mean density that the fluid has along the equipment (used in the procedure for calculating the size of the heat exchanger) and a good approximation of the weight of the fluid is achieved.

Chapter 4 Calculation method

4.1 Introduction

In this chapter the reader will find the description of the calculation method and the tool that was developed in this project. In the past chapter it was mentioned that having superheating will increase the mass of the ORC so evaluations are made to see which the best option is: an extra heater after the evaporator (fig. 3-5) or only the elemental components of the ORC (fig. 3-4). Although an extra heater will produce more energy, extra weight will be added to the system which may be adverse to the purpose of the ORC which is to produce instead of consuming energy (more weight means more fuel consumption). To answer this interrogation, two calculation methods were developed; the first one will evaluate the situation in which only the fundamental components (figure 3-4) work in the ORC and the second one, a second heater is added to the system to increase the amount of heat delivered to the organic fluid. Superheating was chosen among the options presented in figures 3-5 and 3-6 because, compared to a regenerator (fig. 3-6), produces a higher increase in the overall efficiency (since it is used to extract more heat from the heat source). A regenerator would be useful if the heat sink and the working fluid had a small difference in temperature; the regenerator would cool down the working fluid in this stage and transfer some heat to the stage which is before the first heater (see fig 3-6), then condensation would be easier, but since we are using air from the outside, which is about at 60°C below zero, the regenerator would only be used to preheat the refrigerant. But this advantage could not be compared with the extra amount of thermal energy that could be extracted from the heat source with a second heater. So it can be said that the contribution of a second heater is better than that from a regenerator. In conclusion, the comparison will be made between the basic ORC system and the arrangement that could increase efficiency.

There were many parameters already defined from the conditions in the aircraft that will be mentioned in the next chapter, in figure 4-1, the variables, constants and calculated values are shown. The lowest and highest pressures of the system along with the conditions of the heat source and heat sink are the primary values of the calculation; from these the weight of the system is calculated. It should be noted that the mass flow in the heat source and heat sink are shown as variables, this is because the ORC is assessed in different circumstances so a change of these values is needed in further experiments.

A code in MATLAB was developed by the author to automate these calculations (links to the documents are available in the appendix). After a combination of values are assigned to the variables, the code assesses if the system is feasible. This means that if there is any impossibility, regarding the thermodynamic condition of the system (break any of the three laws) the code will stop, and this is noticed by the code if in one point of the process one of the heat exchangers' output temperature crosses the limit of what is thermodynamically possible, if this happens the code gives an overall efficiency equal to zero. Then it will be possible to tell until which point the cycle can exist without breaking any law, this is evaluated through the output temperatures of each heat exchanger. If all the temperatures showed a logical and possible behaviour then the code calculated the weight of the system, the energy output and the energy needed to carry it on board. The weight was calculated after the method of Kays and London [16] explained in the book of Shah [19] and available on the Appendix section of this work. The energy output is obtained doing basic thermodynamic calculations and the way to find the energy needed by a defined mass was with equation 4.1 (from the book of Cumpsty [27]) which defines the extra amount of fuel (m_f) needed per unit of time (T) to carry an extra mass (m_m), the other parameters (L , D , LHV and sfc) are defined in table 4-1.

$$\frac{m_f}{T} = m_m \cdot g \cdot \left(\frac{L}{D}\right)^{-1} \cdot sfc \quad (4.1)$$

The amount of fuel per unit of time is multiplied by the lower heating value (LHV) of jet fuel A-1 to obtain the energy units per unit of time (in Watts) that the extra weight consumes. The same criteria are applied to the process of calculating the weight of the system with superheating. In the Appendix section, the flux diagrams for both processes can be seen on detail. With this tool it was possible to evaluate different conditions and configurations of the ORC, changing one or more of the variables, the results give a clear view of the possibilities that the ORC can manage in the form of graphs produced by MATLAB.

Table 4-1: Conditions of an A320.

Parameters in cruise conditions for an Airbus A320 (35,000 ft and 0.78 Mach)	
Specific fuel consumption (sfc) [28]	1.545×10^{-5} kg/Ns
Lift/Draft (L/D) [29]	15.2
Lower Heating Value (LHV) of jet fuel A1 [30]	42.8 MJ/kg

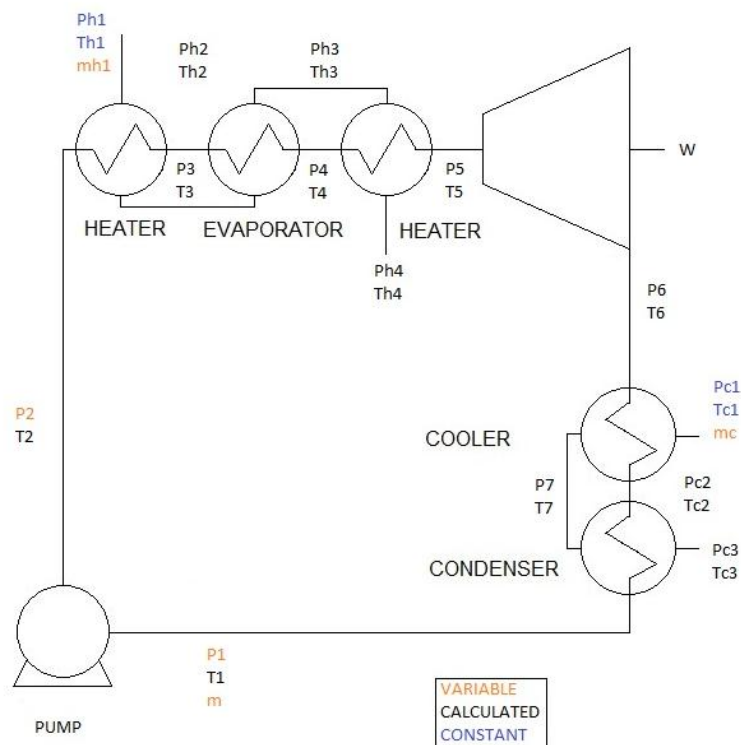

Figure 4-1: Type of data in the ORC.

4.2 Theoretical basis of the calculation method

The calculation method for defining the size of the heat exchanger is the one suggested by Kays and London [21]. This procedure allows to find the core dimensions of a crossflow (or counter flow) single-pass compact heat exchanger. Cross flow design was selected because it needs less surface area to reach its highest efficiency, while a counter flow, the longer it is, the more efficient it gets [31]. Compactness drives to low volumes and thus, lower weights. With the calculation method, the frontal area needed from each stream is obtained, then these two are coupled (see figure 4-2) and the dimensions of the heat exchanger are found. In chapter 9 of the book “Fundamentals of Heat Exchanger Design” by Shah and Sekulic [32] the method from Kays and London is explained step by step, note that this is specifically for crossflow compact heat exchangers, the methods for other types of arrangement can be found in the book. The author says that the dimensions of the heat exchanger depend primarily in the pressure drops, the type of fluid and the number of thermal units needed for the heat transfer on each side. The geometric properties and materials selected also play an important role in the size of the core and are needed for the calculation of the heat exchanger size, these parameters can be found in chapter 10 in the book of Kays and London [21], in this book the reader can find a catalogue with information about the geometric properties for many types of heat exchangers. The method from Kays and London is widely used and recommended by many authors, like Shah [32] and Hewitt [33]; it is a simple step-by-step procedure to get the core dimensions for many types of heat exchangers, it also provides the design data for many geometries and materials.

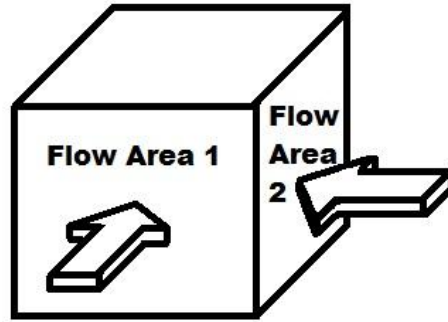

Figure 4-2: Cross flow heat exchanger

4.3 Properties

For calculating the core dimensions, properties from the materials used and the fluids are needed, the first ones were obtained from the book of Kays and London and the second ones from the free thermodynamic library CoolProp, downloaded from www.coolprop.org [34]. This is a free access C++ library that can be downloaded and used with many programming languages like Python, C#, Java and MATLAB. Although it is usual that for works with ORC the softwares FluidProp and RefProp, from ASIMPTOTE and the National Institute of Standards and Technologies (NIST), are commonly used. There is a free version of FluidProp that could be downloaded from the ASIMPTOTE web page[35]. This version contains part of the RefProp library and its independent libraries but not all the properties required in the calculation of the core dimensions are given by this version. For this particular reason, the library from CoolProp was used. As can be seen in table 4-2, the properties needed for the calculation are all available in CoolProp. This library uses, as FluidProp, equations of state to calculate the properties given certain parameters. Even though FluidProp is well recognized for being a reliable and common used tool, the properties from CoolProp were compared with them and the results can be checked in table 4-3 and 4-4. The thermodynamic properties and the characteristics of the geometries are extracted from CoolProp and the book from Kays and London; both sources are reliable for their use in the calculation method for the heat exchanger's dimensions of the ORC as they have been

recognized by other studies: the method from Kays and London used by Shah and Sekulic [32] and the database of FluidProp, applied in the work from Auld et Al. [11].

Table 4-2: Properties available in CoolProp and the free version of FluidProp.

Fluid	Air		R245fa	
Property	Available in FluidProp*	Available in CoolProp	Available in FluidProp*	Available in CoolProp
Pressure	Yes	Yes	Yes	Yes
Temperature	Yes	Yes	Yes	Yes
Heat coefficient	Yes	Yes	Yes	Yes
Viscosity	No	Yes	No	Yes
Thermal conductivity	No	Yes	No	Yes
Prandtl number	No	Yes	No	Yes
Density	Yes	Yes	Yes	Yes
Enthalpy	Yes	Yes	Yes	Yes
Entropy	Yes	Yes	Yes	Yes

*Free edition of FluidProp.

Table 4-3: Comparison of available properties of air in CoolProp with FluidProp.

Property	Fluid	Unit	CoolProp	FluidProp	% Difference
Pressure	Air	Pa	101325	101325	-
Temperature		K	298.15	298.15	-
Heat Capacity		J/kgK	1006.3	1014.7	0.828
Viscosity		Pa·s	1.84E-03	-	-
Thermal conductivity		W/mK	0.0262	-	-
Prandtl Number		-	0.7073	-	-
Density		kg/m ³	1.1843	1.1799	0.373
Difference in Enthalpy*		J/kg	10060	10148.5	0.872
Difference in Entropy*		J/kgK	33.20	33.5	0.896

*Difference with same pressure and 308.15K.

Table 4-4: Comparison of available properties of R245fa in CoolProp with FluidProp.

Property	Fluid	Unit	CoolProp	FluidProp	% Difference
Pressure	R245fa	Pa	100000	100000	-
Temperature		K	288.15	288.15	-
Heat Capacity		J/kgK	873.6117	847.3	3.105
Viscosity		Pa·s	1.14E-05	-	-
Thermal conductivity		W/mK	1.0149	-	-
Prandtl Number		-	0.6701	-	-
Density		kg/m ³	5.8387	5.7993	0.679
Difference in Enthalpy*		J/kg	8810	8561.9	2.898
Difference in Entropy*		J/kgK	30.10	29.3	2.730

* Difference with same pressure and 298.15K.

4.4 Pressure drop in the heat exchangers

The method from Kays and London for designing heat exchangers that was used on this work tells that, for finding the pressure drop of the heat exchanger designed, one should use equation 4.2 using the parameters from the calculations for designing the heat exchanger.

$$\Delta p = \frac{G^2}{2g_c\rho_i} \left[(1 - \sigma^2 + K_c) + 2 \left(\frac{\rho_i}{\rho_o} - 1 \right) + f \frac{L}{r_h} \rho_i \left(\frac{1}{\rho} \right)_m - (1 - \sigma^2 + K_e) \frac{\rho_i}{\rho_o} \right] \quad (4.2)$$

The terms refer to entrance loss, flow acceleration loss, core friction and exit loss, respectively. Most of the terms in the equation are thermodynamic properties obtained from the conditions of the organic fluid at a certain moment, for example the density of the fluid when it gets into the heat exchanger (ρ_i) and when it gets out of it (ρ_o). Some terms depend on the geometry, material and dynamic characteristics of the fluid (like σ and Re). The terms K_c, K_e values depend on the cross-sectional flow geometry σ and Reynolds number, these values are given by Kays and London on graphs with empirical data for a specific type of geometry (triangular and parallel fins) which is different from the one used on this project. Because of this lack of data, and to take into account a pressure drop on the equipment, a constant loss of 10% was added to the calculation method on every heat exchanger. Although this is not accurate it gives an approximation of the pressure drops due to the heat exchanger areas. To find the real value it is needed to generate empirical data using the type of heat exchangers used on this project (finned-tubes and plate fins).

4.4 Validation

Two works were used to validate the calculation method used in this project; the comparison between them is showed in tables 4-5 and 4-6. The first comparison is made with the work made by Aneke et al. [36], who modelled an ORC for comparing it to a real system in the Chena Geothermal ORC Power Plant, the aim of this project was to “*investigate the effect of variation in the geothermal source temperature on plant performance*”[36]. The

parameters of Aneke's work were introduced in the ORC calculation method. The refrigerant for his work is R134a so it was needed to be changed. The library of CoolProp supports the use of this refrigerant so there was any problem caused by this change. Since the operations "call" the properties from CoolProp, the only needed modification in the code consisted in the change of the name of the refrigerant in the functions, the rest stayed the same, an example of how enthalpy ('Hmass'), at a given temperature in K ('T', 300) and pressure in Pascals ('P', 15000), is called from CoolProp is shown below.

```
Enthalpy = CoolProp.PropSI('Hmass', 'T', 300, 'P', 150000, 'R134a');
```

The efficiencies of the equipment were also input to the method. For a second comparison, an ORC integrated to an engine CFM56-7B was chosen, the purpose of this project from Perullo et Al. [8] is to take advantage of some of the energy wasted as heat from the nozzle of the engine. Integrate an ORC in the engine involves a change in the architecture of it, the main problem with this work was the materials and the needs of the ORC, very big and heavy heat exchangers were needed and that made it unfeasible for its objective. In this case, the same refrigerant (R245fa) is used and the results are similar in both procedures. It was intended to show the comparison between the dimensions of the heat exchangers used in the ORC of this project and the one from Perullo et Al. but key specifications from the heat exchangers, like the description of the geometry and materials used, were not specified by the authors, a rough calculation was made to estimate the volume of the evaporator taking the same characteristics of the heat exchangers used in this project, the difference in the heat exchanger dimensions was of 25% being the one estimated bigger than the original.

The output values from each work were calculated using the code developed by the author and the results shown in tables 4-5 and 4-6 compare them with the original values of each work. The relative difference for many parameters between them is displayed in the last column of each table. The values for which the relative difference is equal to zero are

parameters that were introduced to the code developed by the author in order to calculate the other values.

Table 4-5: Validation with the work of Aneke et Al.

Parameter	Aneke et al. model	Present model	Relative difference (%)
Working fluid	R134a	R134a	-
Turbine efficiency (%)	0.8	0.8	0
Work turbine (kW)	250	264.59	5.84
Pump efficiency (%)	0.305	0.305	0
Work pump (kW)	40	42.187	5.47
T-in pump (K)	284.80	284.80	0
T-out pump (K)	286.01	285.43	0.20
T-in turbine (K)	337.37	336.87	0.15
T-out turbine (K)	289.70	289.04	0.23
Evaporator heat transfer (kW/h)	2570.38	2570.4	0
Condenser heat transfer (kW/h)	2327.1	2327.1	0
Net power (kW)	210	222.41	5.91
Thermal efficiency (%)	0.08	0.0946	18.25

Table 4-6: Validation with the work of Perullo et Al.

Parameter	Perullo et al. model	Present model	Relative difference (%)
Working fluid	R245fa	R245fa	-
Turbine efficiency (%)	0.77	0.77	0
Work turbine (kW)	186.43	185.52	0.49
Pump efficiency (%)	0.58	0.58	0.52
Work pump (kW)	5.97	5.94	0.40
T-in pump (K)	250	250	0
T-out pump (K)	250.56	250.84	0.11
T-in turbine (K)	391.66	391.66	0
T-out turbine (K)	318.89	326.08	2.25
Evaporator heat transfer (kW/h)	1104.64	1104.6	0
Condenser heat transfer (kW/h)	902.07	902.07	0
Net power (kW)	179.71	178.58	0.63
Thermal efficiency (%)	0.1834	0.1834	0.01

Tables 4-5 and 4-6 show the comparison between the input and output parameters of the organic Rankine cycles from the works of Perullo et Al. and Aneke et Al. and similarities on them are visible. The first table make reference to an ORC that is used in a geothermal

power plant. The software IPSEpro was used to determine the heat balances in every point of the system; from this data, available in the article [36], input and output conditions of the different components were taken and put in the designed model. The relative error shows values that are higher than five percent; the application and the considerations that the software takes to calculate the heat balances causes these values, the other values, lower than one percent demonstrate that the thermodynamic calculations of this work are logical. The second table compares the parameters obtained from the ORC designed to be on board. This model was designed using MathCAD 2001 software. The results show low values of the relative error, being the higher the outlet temperature from the turbine, this may be due to the fact that not absolutely all of the parameters of the system are given in the article [8] so, actually this kind of differences were expected. Both comparisons validate that the calculation of the thermodynamic parameters are reliable in this work, differences in them could be explained; the cause of these situations rely in the fact that different software and amount of parameters were taken for doing the calculations. Overall this gives confidence in the method developed by the author for this MSc(R).

Chapter 5 Environmental conditions

5.1 Introduction

Two main sources of waste heat were assessed in this project: the hot air used in the cabin and the air coming from the engine for the pneumatic system, both scenarios happening on Airbus A320 during cruise. Works that used an ORC to recover waste heat in an aircraft [6, 8] found that the amount of energy that can be recovered from the engine is not enough to compensate the energy needed to carry the system on board, having difficulties with all the needed modifications to the engine (heat exchangers mainly). If it was the case, due to the high quality of the heat in the nozzle, a Rankine cycle with water as working fluid may be an option. In this study, both sources of heat are of low quality. A general diagram of the pneumatic system is showed on figure 5-1 [17] . The source of bleed air comes from two stages of the compressor, high and intermediate, a valve regulates them for getting a constant flow into the pneumatic system. After the heat comes out of the compressor it is cooled down in the precooler, which uses cold air coming from the fan. After this point the bleed air has the ideal conditions to get into the pneumatic system. In this point the air flow separates to supply many services including the air conditioning pack, cabin ventilation system, potable water pressurization, wing and engine anti-ice protection, air-driven hydraulic pump, hydraulic reservoir pressurization, cargo heat, and cabin pressurization [17]. In figure 5-1 a diagram of the bleed air system of an Airbus A320 is shown, this diagram was taken from the Airbus flight crew operation manual [37] this location and the one before the precooler are the two options to be evaluated with an ORC. Figures 5-2 and 5-3 show the places where the ORC system will be assessed. In both cases a heat source and a heat sink are available, the engine is not compromised and the conditions are acceptable to put there an ORC, in both

cases the process of extraction of heat from a fluid and drop it out the system is required, the aim of the ORC is to recover part of this heat and reintegrate it to the system.

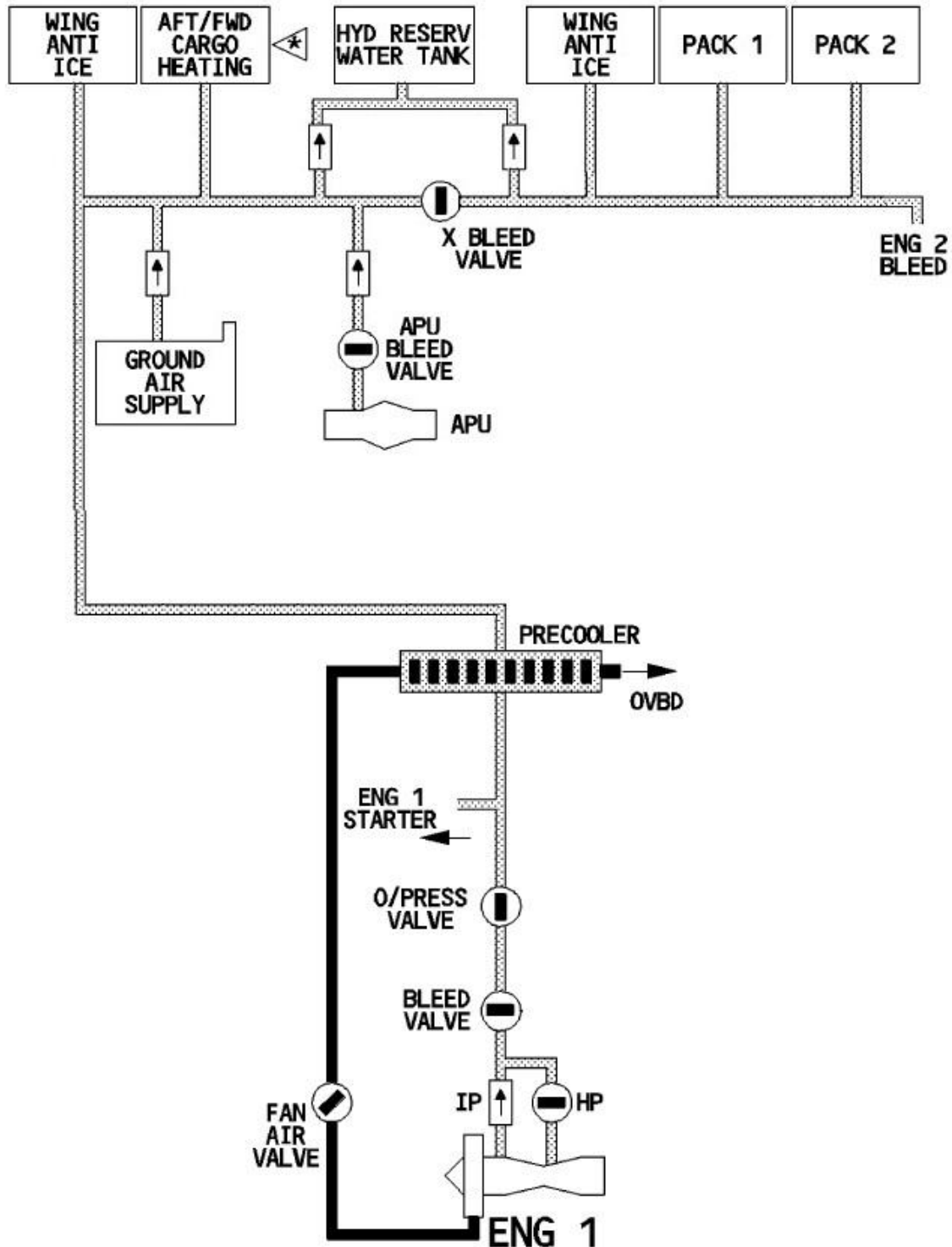

Figure 5-1: Modified diagram of bleed air system from the flight crew operating manual [37].

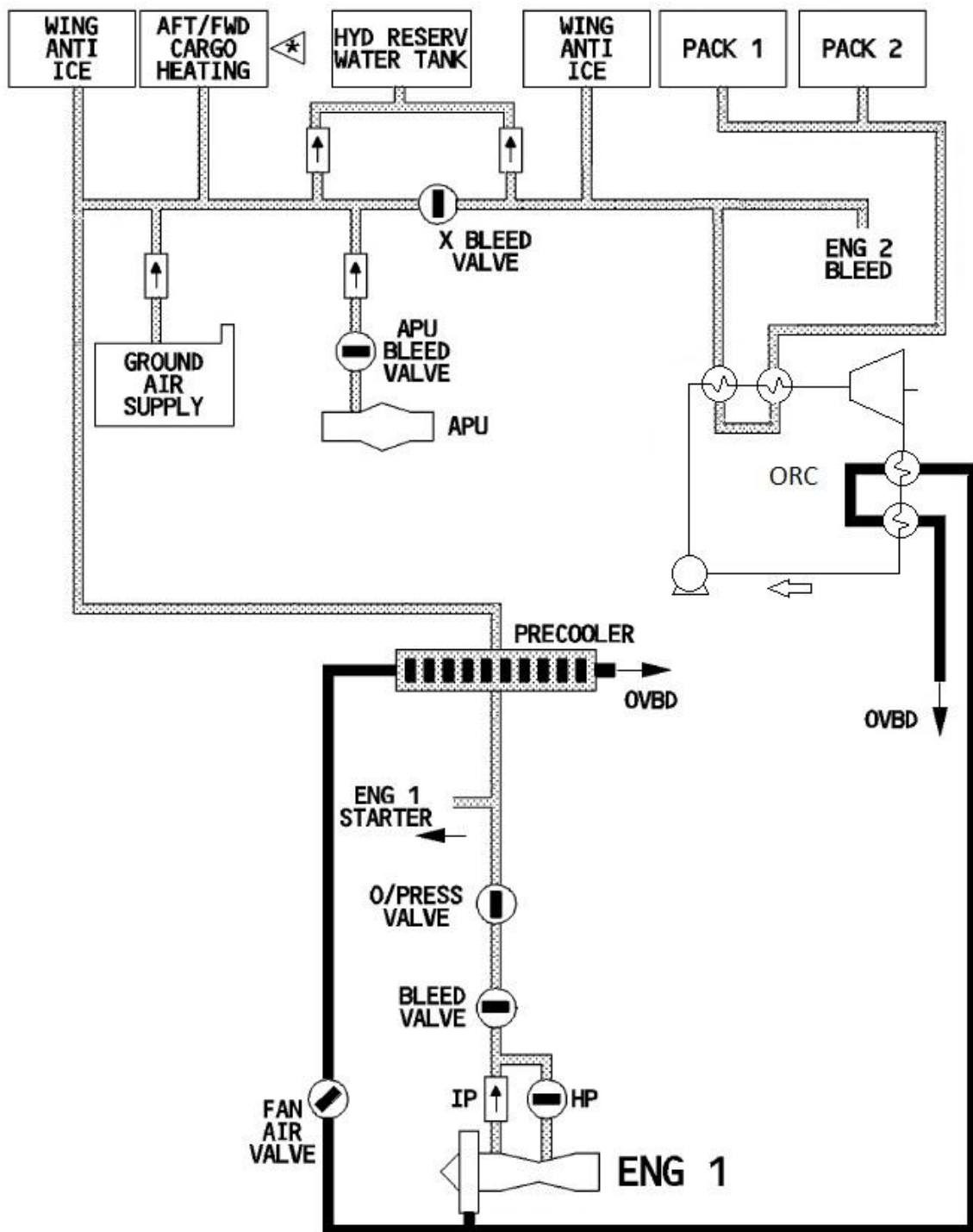

Figure 5-2: Modified diagram of bleed system from the flight crew operating manual [37] with ORC before the AC Packs.

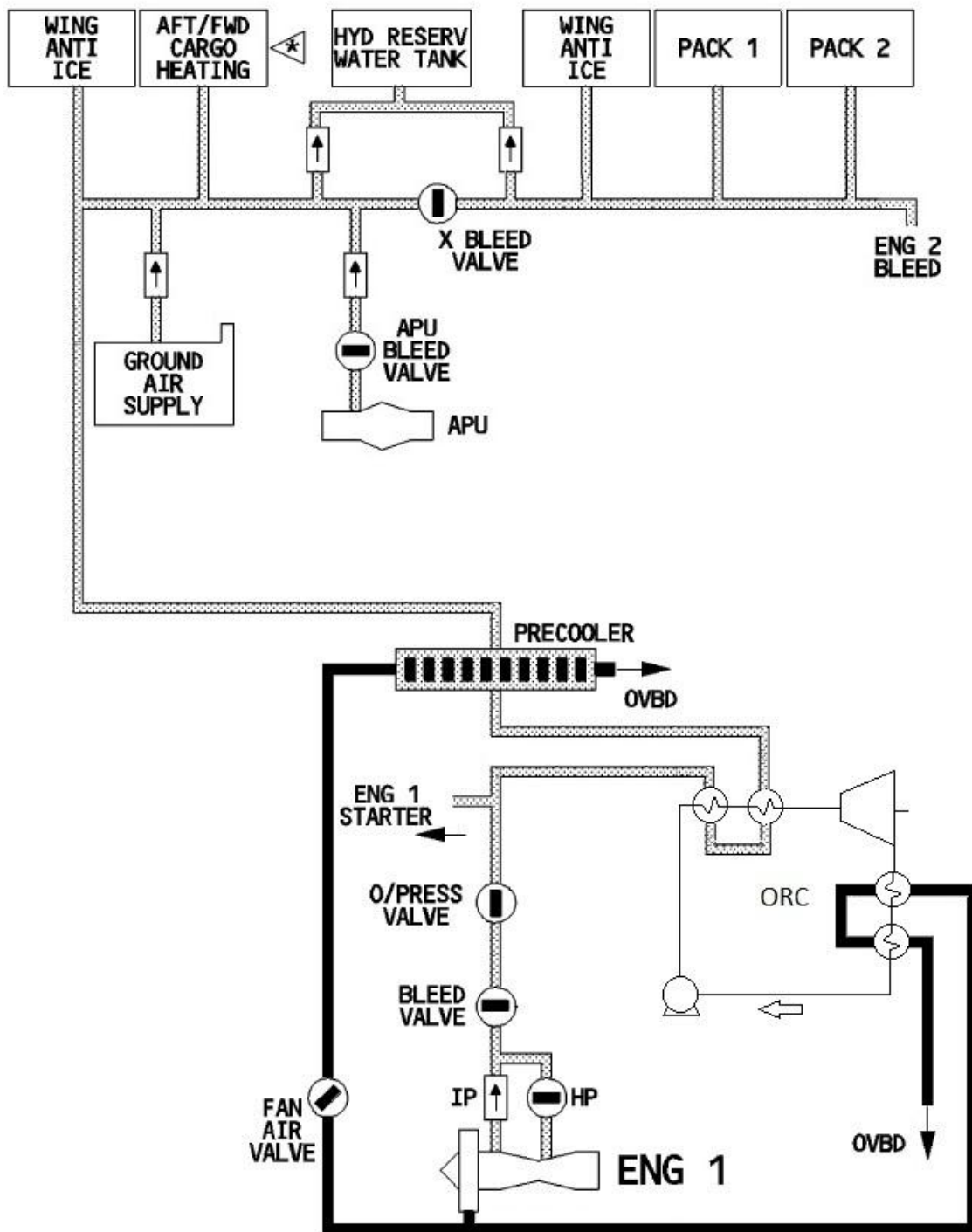

Figure 5-3: Modified diagram of bleed system from the flight crew operating manual [37] with ORC before the precooler.

5.2 Air Conditioning Packs

Figure 5-4, shows a diagram on how the bleed air enters into the aircraft and then it branches into several systems, one also can see how the ram air is used to cool down the bleed air; the AC Packs are detailed so the reader can get a clear view on how they work. The air conditioning (AC) system receives air coming from the precooler and lowers its temperature using ram air from the outside. With a temperature of about 200 °C, the air conditioning pack (one of each side) uses air from the outside at about -50 °C, depending on the altitude, to extract the heat from the air [37]. The heat energy is released to the atmosphere and the air, now with appropriate conditions of temperature, pressure and mass flow, is ready to enter into the cabin. The mass flow of the ram air, coming from the outside, is regulated to attend the circumstances on real time of the aircraft. Figure 5-5 [38] shows the inlet flap, also called NACA inlet, in the bottom of the aircraft which is connected to the AC Pack (figure 5-6 [32]) to deliver ram air. The mass flow of the ram air is not defined because it is a parameter that changes depending on the needs of heat exchange. This parameter was varied according to the needs of the system, aiming to obtain the most amount of energy produced with the ORC. On the other side the pressure and the temperature are known values for the altitude at which cruise velocity is reached. The cruise altitude of an Airbus A320 is 35,000 ft [28], the temperature at this height is of -54.3 °C and 24500 Pa according to an online reference [39]. Placing the ORC system before the AC pack will let us recover part of the energy of the hot air coming from the precooler, for generating electrical power and cool down the air, instead of releasing all the heat to the atmosphere. The temperature in the cabin should be 22 ± 2 °C and a pressure of about 100 kPa should be met; these conditions provide a comfortable environment for the passengers [14] and are the limits of the air coming out from the ORC, as shown in the diagram in figure 5-2. The FAA requires that “For normal operating conditions, the ventilation system must be designed to provide each occupant with

an airflow containing at least 0.55 lb of fresh (outside) air per min” [40], multiplied by the amount of passengers that an A320 can carry (180 max.) [41], and converting to SI units we get ≈ 0.8 kg/s; since this is the least an AC pack can provide, the amount was rounded to 1 kg/s. The ORC placed in this point is not intended to substitute the AC packs but to lower the temperature in the way between them and the precooler. The possibility in which the ORC substitutes the main heat exchanger of the AC packs is also an option that should be studied in further research, the system could be dynamically controlled to deliver, constantly, air in certain conditions; this is not the purpose of this work, but to meet certain conditions of pressure and temperature of the organic fluid in the ORC system.

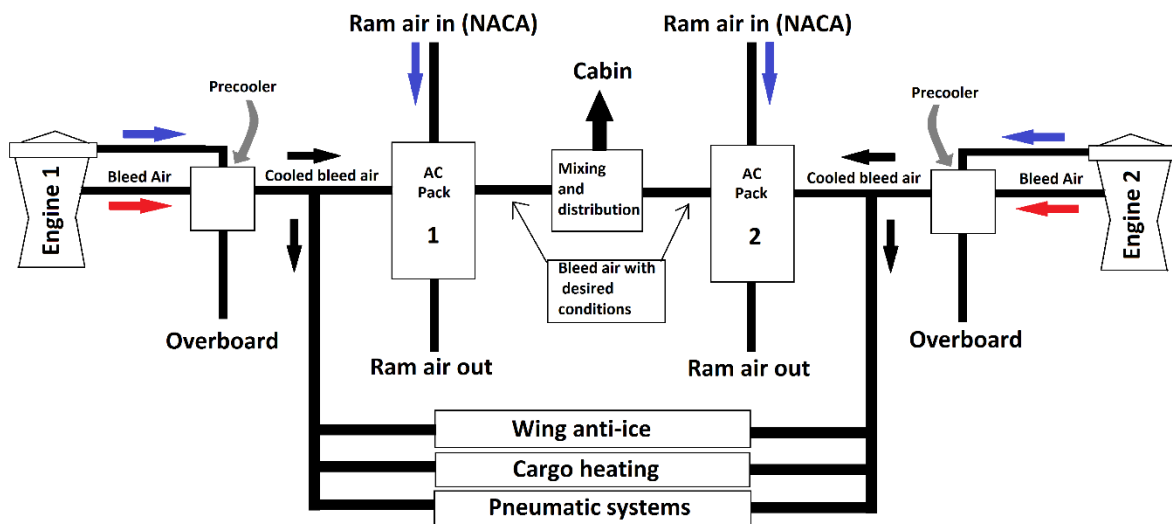

Figure 5-4: Diagram of the bleed system.

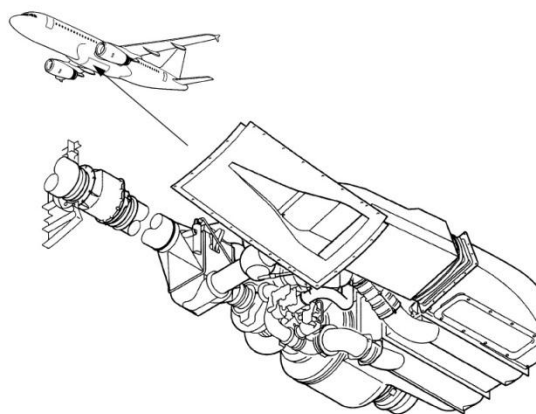

Figure 5-5: NACA air inlet [38].

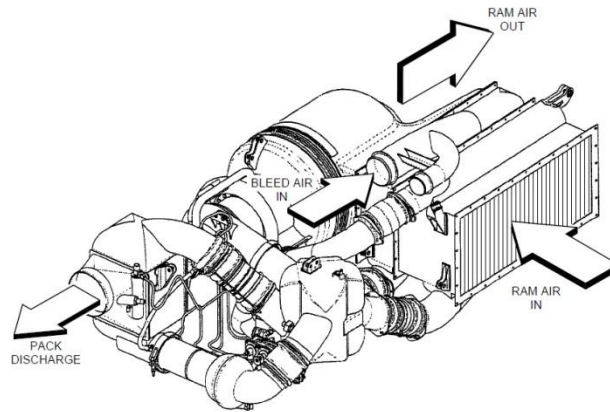

Figure 5-6: Diagram of AC Pack [38].

5.3 Precooler

The precooler system uses air coming from the fan, with high pressure and low temperature, and cools down the bleed air coming from the compressor in the engine to deliver it at 24 kPa [37, 39] and a temperature of 215 °C [17]. The cold air coming from the fan is released to the atmosphere with the heat energy in it. Figure 5-7 [40] shows in detail this part of a typical bleed air system. This air is regulated before getting into the precooler by the bleed monitoring computer, and the conditions depend on the needs and environmental circumstances. Air is normally taken from the intermediate and high pressure stage from the engine [18]; if the air was constantly taken from the high pressure then the fuel penalty would be higher so the air from this stage is extracted only when the conditions of the intermediate stage are not enough to satisfy the needs of the pneumatic system, for example when the engine is running at low speed, the bleed system takes air from the high and intermediate pressure stages at the same time [38]. The high stage can deliver pressures of 1,020 kPa and temperatures around 450 °C [18], these conditions exceed the needs of the pneumatic system and for this project they are of particular interest since they represent a large source of energy. The maximum permissible air bleed extraction according to the European Aviation Safety Agency is of 12% [19] of the primary airflow in the engine, this is equivalent to 2 kg/s

[42]. The extraction of such amount of heat from the engine would need to be compared with the lost in energy, the ORC calculations for this circumstances were made to see the potential that this source represent but it is important to note that the extraction of the energy from the engine is taken partially into account. The bleed air system represents a loss in energy for the engine, as it takes pressure and heat from it [16] many project proposals have been made to make it entirely electric but the change of the engine's architecture and the need of combining this to the existing technologies is the main reason why aircraft still work with conventional bleed air systems. The precooler is a component that uses cold air to cool down the air coming from the engine and deliver it to the pneumatic system, the energy extracted from this hot air , using a compact heat exchanger, is released into the atmosphere as waste heat, an ORC system can be placed here to assess the recovery of this energy; the air coming from the bleed system is a potential high source of energy that can be recovered, this work assess this situation taking into account the thermodynamic characteristics that the air coming out the precooler should have.

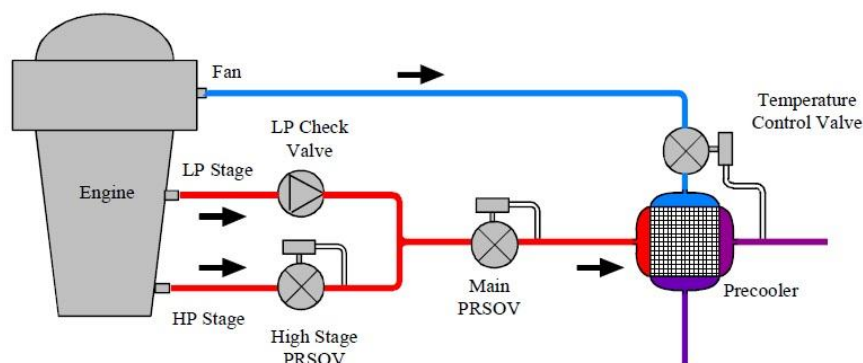

Figure 5-7: Bleed System by Rydock [35].

It is recalled that the temperatures and pressures used for this project from the heat sources and heat sinks correspond to the conditions existing in cruise conditions. In table 5-1 a summary of these parameters is given. The extraction from the secondary flow in the engine, which comes from the bypass duct, is regulated by the European Aviation Safety

Agency; who stipulates that a maximum of 2% of the air that enters into the engine, and is not used for combustion (secondary mass flow), can be extracted to the bleed air system [19]. Taking this into consideration, the maximum mass flow of the ram air was calculated and limited to 4 kg/s. These conditions were the ones used in this work for assessing the ORC, cruise conditions are the most representative on an aircraft, climb and landing, occur on a short period of time, although in climbing the most energy is released per unit of time, this circumstances were not evaluated.

Table 5-1: Summary of conditions.

	Precooler	Air conditioning Pack
Heat Source	Air coming from the engine	Air coming from the precooler
Temperature	450 °C	204.44 °C
Pressure	1020 kPa	206.843 kPa
mass flow	2 kg/s	1 kg/s
Heat Sink	Air coming from the fan	Ram air used to cool down the air
Temperature	-54 C	-54 C
Pressure	24 kPa	24 kPa
mass flow	1-4 kg/s	1-4 kg/s

5.4 Conditions of the organic fluid

Many studies on organic fluids for ORC have been made in order to obtain the best conditions to get the most energy into the fluid and thus, produce the highest amount of work output. The selection of the organic fluid depends strongly in the heat source. Decomposition of the refrigerant due to the high temperatures and pressures is possible if these are not taken into account. Bao and Zhao present in their work [22] the practical higher and lower limit of the cycle for a wide variety of working fluids. These bounds are shown, for the R245fa, in table 5-2 and were considered, along with the conditions of the heat sink and source, to select the values used in the calculation method. The maximum pressure and temperature values

used in this work are below the values recommended by Bao and Zhao because if the highest values were taken, then a higher source of energy would be needed to achieve those conditions. The lower values on the other hand were used as the authors recommend, the conditions that the heat sink has, allow the system to reach these parameters.

Table 5-2: Highest and lowest limits of pressure and temperature for the organic fluid.

	Units	Values recommended by Bao and Zhao [22]	Values used in this work
Maximum P_{eva}	(MPa)	2.817	2.05
Maximum T_{eva}	(°C)	140	96.01
Minimum P_{con}	(kPa)	149.4	150
Minimum T_{con}	(°C)	25	25.15

The values selected for the maximum and minimum pressures and temperatures for the ORC are inside the values recommended by Bao and Zhao, taking the same number in the case of the minimums and choosing values not far from the higher limit. With this selection of limits it is intended to get the most of the energy coming from the heat source in accordance with the amount of heat available and at the same time prevent the decomposition of the fluid due to an excess of heat energy.

Chapter 6 Results

6.1 Introduction

The assessment of the ORC was done in different scenarios in order to find out where it worked the best; in many cases the system won't produce enough work output to cover the amount of energy taken from the fuel to carry the equipment on board, this situation depended on many factors like the place of the system or the number of heat exchangers. There were two positions evaluated for the ORC, as shown in figures 5-2 and 5-3: before the precooler (using air coming directly from the engine) and before the AC pack (using air coming from the precooler). The difference between these locations is that in the first case mentioned (precooler), the temperatures and pressures of the air are much higher than the ones in the entrance of the AC Pack (see table 5-1). As said before, even more energy is collected by the organic fluid when superheating is added but an extra weight is added since more area is required to transfer the energy and, besides this, now that higher temperatures are reached in the system, the cooler will need more area in order to be able to condensate the organic fluid.

So, in total, four different scenarios were evaluated, and four graphs were generated. For each scenario, eight different mass flows for the heat sink (cold air from the outside) were assessed so every graph contains eight lines. Each of them is composed by dots and every dot represents an ORC calculation. For each of the 4 scenarios, 6088 combinations were calculated. In the graphs are plotted only the ORCs that do not break any thermodynamic restriction. For each line, the point referring to the highest mass flow of the organic fluid denotes the last possible ORC for that line of dots, after this point the system is not thermodynamically possible with the stated mass flow of the cold air; this is why many mass flows for the cold air were assessed. In some graphs a sort of "jump" can be seen, this is

because the calculation procedure changes when the mass flow of the organic fluid reaches a point when the air, and the organic fluid, have the same rate of heat transfer. The variables for producing the graphs were the mass flow of the organic fluid and the mass flow of the cold air used for the cooler and the condenser, by changing these values, a wide variety of results are obtained and a good and clear picture of the conditions can be seen. The graphs show that the system could be successfully integrated into the aircraft for heat recovering if it is placed before the precooler. In the case of placing an ORC before the AC Packs, the energy in the air that is intended to be recovered is not enough to cover the amount of energy needed to the system on board.

6.2 Presentation of key results

From the configuration in figures 3-5 and 3-6 two settings were established in the MATLAB code: an ORC with a heater and an evaporator, and another ORC with these two components plus a second heater after the evaporator for superheating. These two configurations of an ORC were assessed in the two locations: before the precooler and before the AC Packs.

A first view of the difference between a system with and without superheating is shown through the Mollier diagrams, in figures 6-1 to 6-4 the pressure-enthalpy and the temperature-entropy configurations for a system with and without superheating are displayed. In the entropy-temperature diagrams the work available in the system is inside the coloured lines, adding a second heater after the evaporator allows getting an extra amount of area as seen in the graphs and this is translated into an extra amount of work derived by the use of this configuration. These two pairs of graphs correspond to two systems where the input parameters are all the same and the mass flow of the organic fluid and the one of the cold air are 0.9 and 2.5 kg/s respectively.

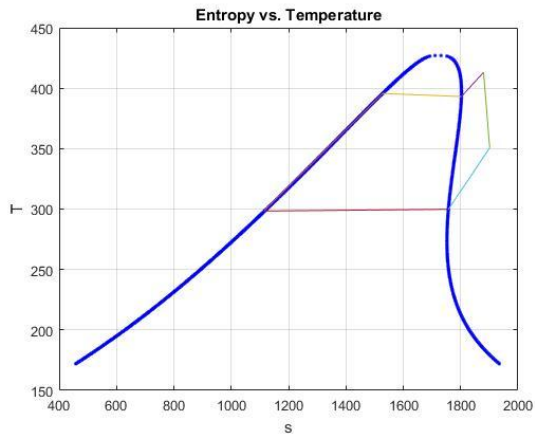

Figure 6-1: T-s diagram for system A

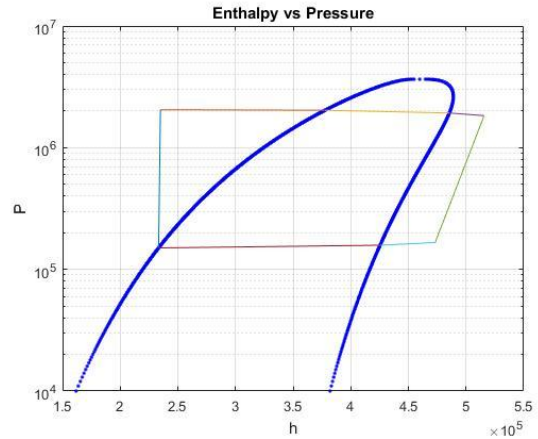

Figure 6-2: P-h diagram for system A.

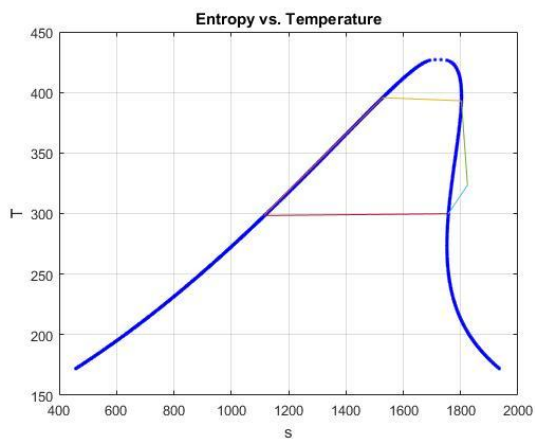

Figure 6-3: T-s diagram for system C.

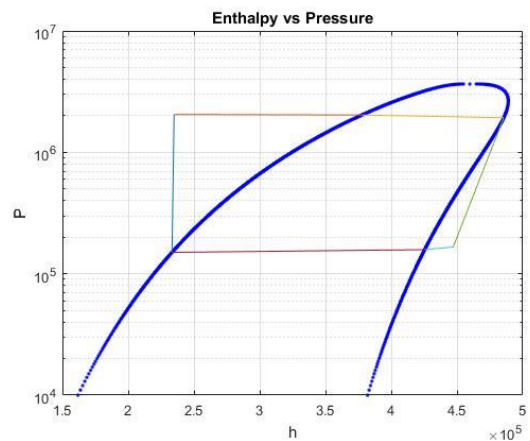

Figure 6-4: P-h diagram for system C

In the diagrams showing the enthalpy versus the pressure, the blue line in the left side of the polygon shows the increase in pressure given by the pump, this component is responsible of giving the corresponding pressure to the fluid and then the first heat exchanger take the fluid temperature into the saturation curve (orange line) and finally the evaporator take it to the other side of the curve corresponding to the vapour saturated state (yellow line). In the case a super heater is used an extra step is taken to the zone of superheated vapour, as seen in the first Mollier diagram and after this, the expander lows the pressure towards the lower pressure limit.

The code developed in this work is derived in two parts; the first part calculates the thermodynamic properties and the second, the weight of the system. Is in the first part where

the system is evaluated and if it is not physically possible then the second part of the code is not executed. On next pages are shown four different ORC diagrams (figures 6-6 to 6-9), each of them representative of one of the four scenarios. They refer to different conditions of mass flow of the organic fluid and the hot air input; the aim this diagrams is to show the reader which are the parameters that the code calculates. The results can be compared with the graphs at the end of this section. In the centre of the diagrams, the thermal efficiency along with the net work output is shown. This is calculated in the first section of the code, the second section provides the two extra results in the diagrams located in the lower left corner: the weight of the system and the saved energy. The total weight is a sum of the weights of the components, the piping system and the fluids in the system; a table with the analysis of the weights of each component is presented for each ORC displayed. With equation 4.1 the amount of energy from the fuel that has to be used to carry on board the system is calculated. The saved energy is equal to the net work produced by the ORC minus the amount of energy needed to carry the system in Watts (see equation 6.1).

$$\textit{Saved energy} = \textit{energy produced} - \textit{energy needed} \quad (6.1)$$

Below in figure 6-5 are two Mollier diagrams showing the temperature-entropy relation of the ORCs. The first refers to the cases where superheating is present and the second one displays the conditions when superheating is not present. The pressure before and after the pump is the same for the four runs and this drives to get the same entropy-temperature diagrams in the two cases.

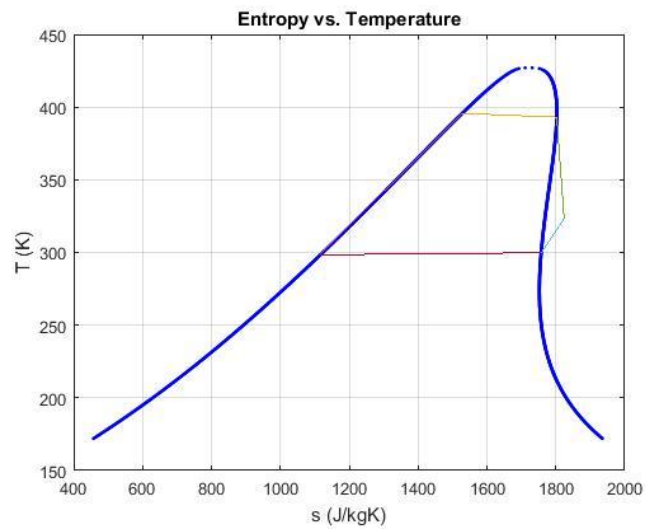
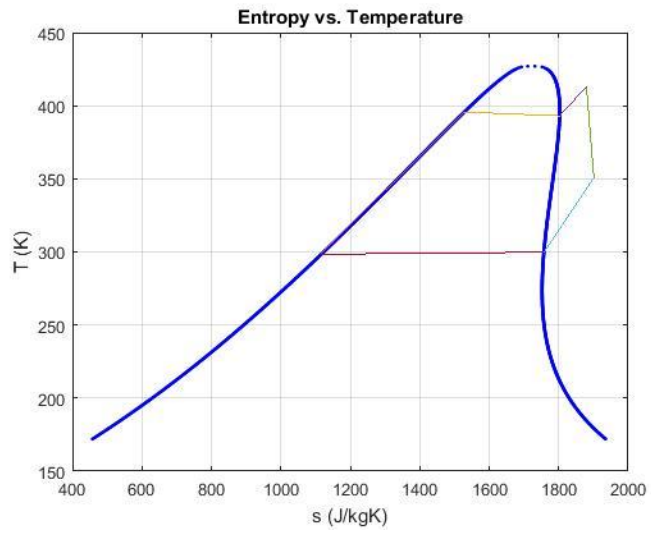
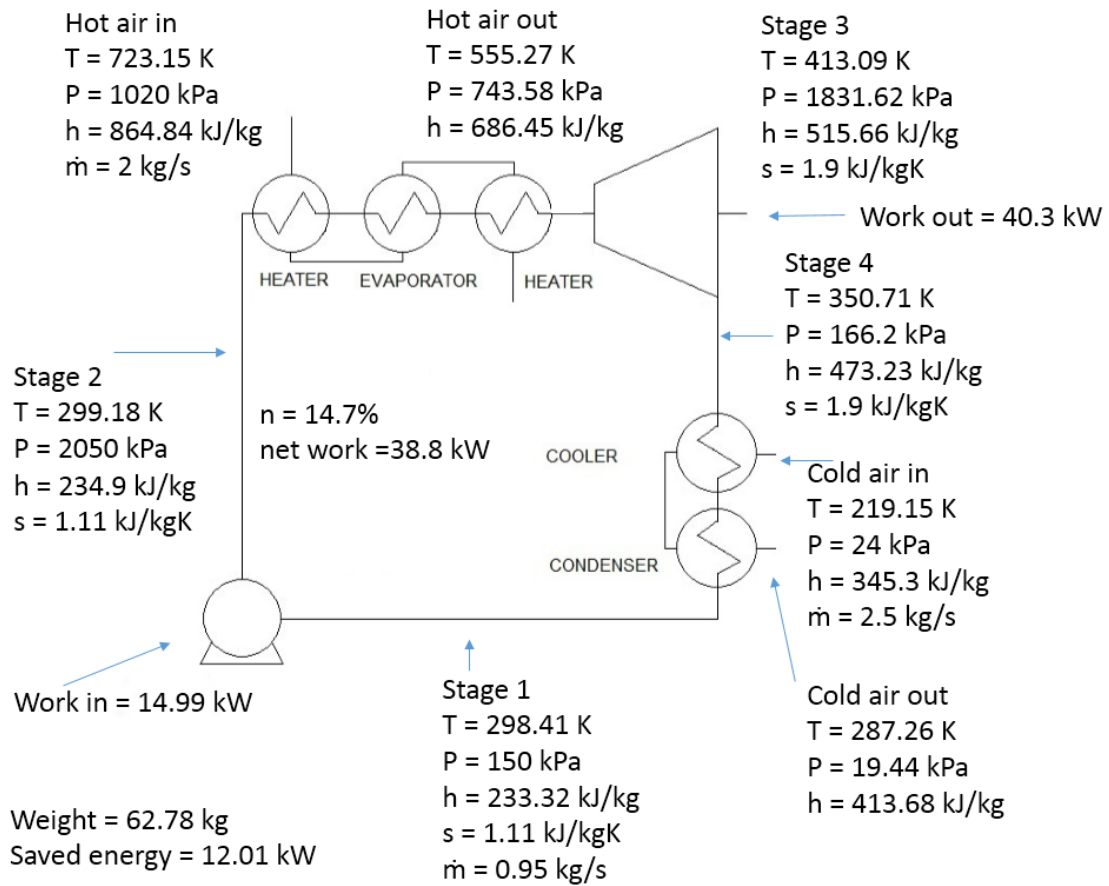
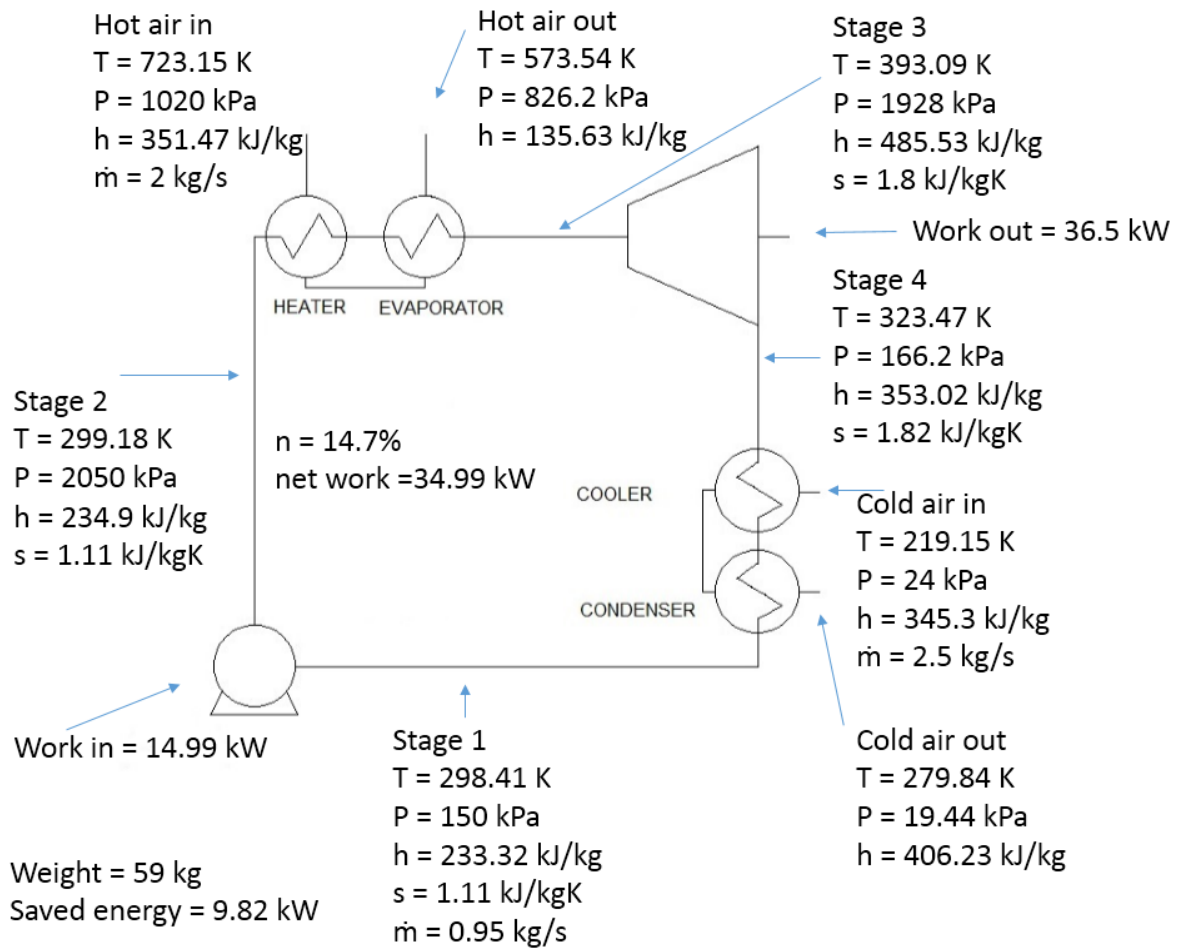

Figure 6-5: entropy-temperature diagrams, top: when superheating is present and bottom: when just the elemental components are present.



Precooler superheating	
Object	Weight (kg)
Pump	2.50
Heater	12.08
Evaporator	1.05
Superheater	3.44
Turbine	1.00
Generator	10.00
Cooler	7.03
Condenser	15.22
Air	0.15
Organic Fluid	4.8
Pipes	4.5
Total	62.77

Figure 6-6: Diagram of ORC before the pre-cooler with superheating.



Precooler no superheatng	
Object	Weight (kg)
Pump	2.50
Heater	12.07
Evaporator	2.05
Turbine	1.0
Generator	10.0
Cooler	6.90
Condenser	15.26
Air	0.14
Organic Fluid	4.56
Pipes	4.5
Total	59

Figure 6-7: Diagram of ORC before the pre-cooler.

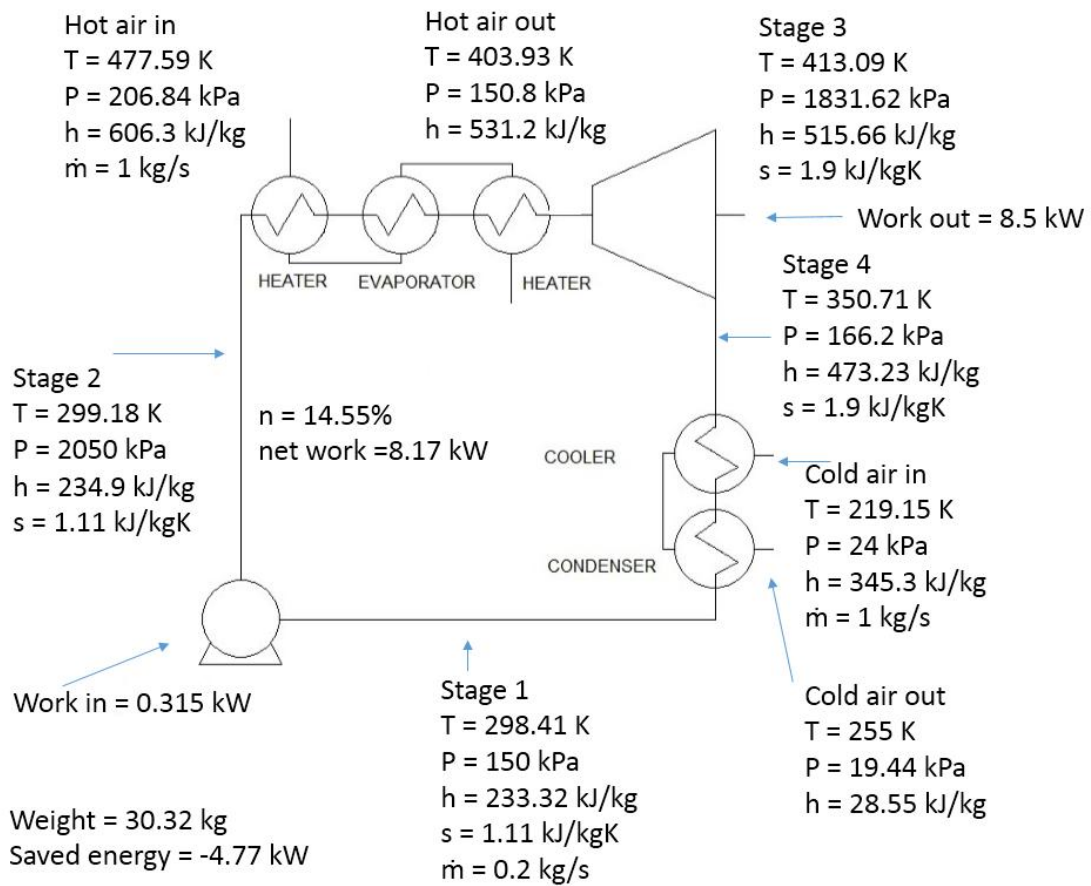

AC superheating	
Object	Weight (kg)
Pump	2.5
Heater	1.43
Evaporator	2.02
Superheater	0.64
Turbine	1.00
Generator	10.00
Cooler	1.24
Condenser	6.15
Air	0.01
Organic Fluid	0.82
Pipes	4.5
Total	30.032

Figure 6-8: Diagram of ORC before the AC Packs with superheating..

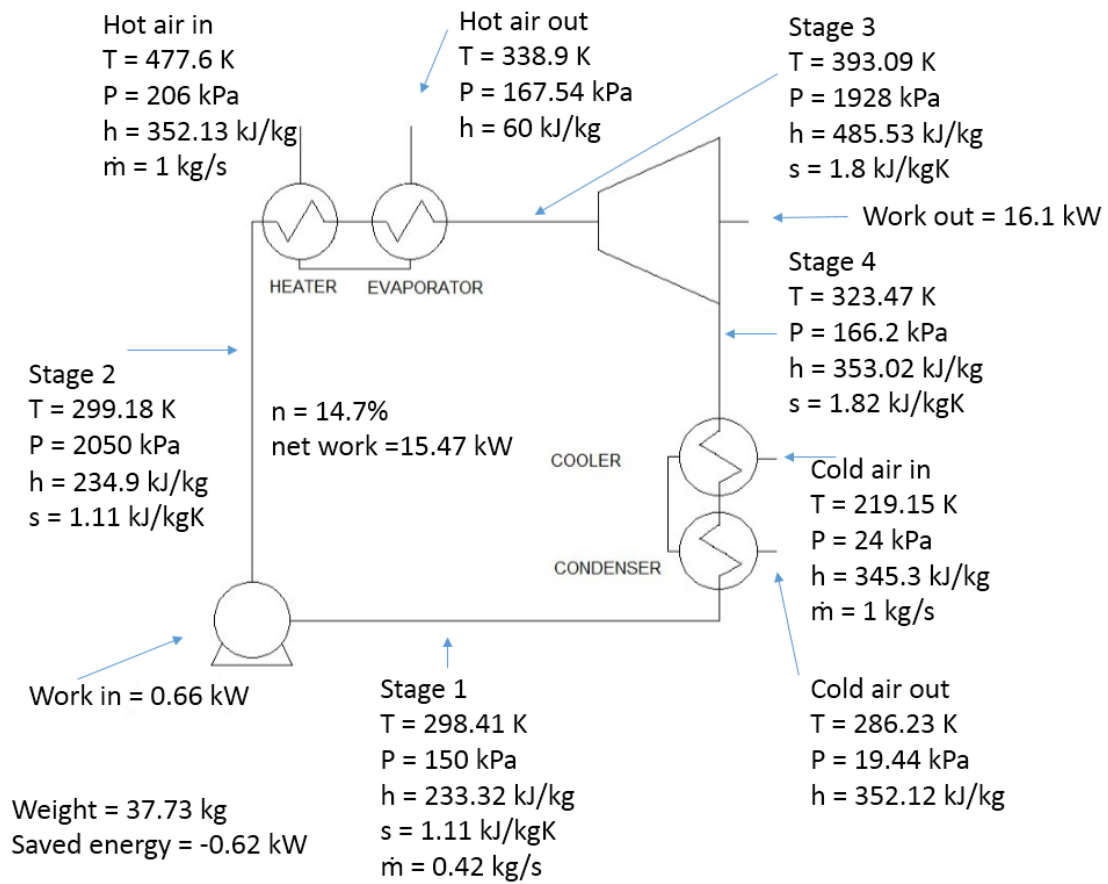

AC no superheating	
Object	Weight (kg)
Pump	2.5
Heater	6.01
Evaporator	1.99
Turbine	1.0
Generator	10.0
Cooler	3.24
Condenser	6.08
Air	0.02
Organic Fluid	2.36
Pipes	4.5
Total	37.73

Figure 6-9: Diagram of ORC before the AC Packs..

In these cases the mass flow of the air used for cooling and condensing is the same for the four diagrams presented in figures 6-1 to 6-4. This mass flow of air comes from the outside at low temperature and pressure and its entrance into the precooler and the Environmental Control System is controlled in both cases with a valve. Depending on the current needs and available conditions would be the amount of air entering into the systems, so for this work, the mass flow of air is a variable which range is between 0 and 4 kg/s, this in accordance of what the EASA [19] stipulates concerning about the amount of air that can be extracted from the fan for cooling applications. The amount of possible ORC's is considerably high since we have two variable 'mass flows' and four possible systems. With the automatization of the calculation method the production of results was not a problem and a clear picture of the situation, the possibilities and the greatest amount of energy are all visible in the graphs.

Comparing the results obtained in the four diagrams shown above, a same behaviour in the results is visible: when a super heater is added the amount of energy is higher and the thermal efficiency is higher as well. The weights found are small because the mass flow of the organic fluid (0.2 kg/s) is low. The condenser in all the cases contributes with the highest weight, this is because it is composed with finned tubes (heavy components) and the amount of area needed by the cold fluid to take the heat off from the hot fluid is in every case, high in comparison with the other areas. Since we are having small systems in this point the amount of saved energy is always negative, meaning that the energy produced by the ORC is not enough to cover the energy used to carry the system on the aircraft.

The graph showed in figure 6-9 is the one corresponding to the case where the ORC is placed before the precooler and there is superheating. Each one of the curves in the graph represents the calculation of saved energy (Equation 6.1) for a given mass flow of cold air, visible in textboxes at the end of each curve. For each dot an independent calculation of the

data displayed in the figures 6-10 to 6-13 was made. The mass flow of the organic fluid is in the x axis and the amount of energy, as can be seen may be a negative or positive number. If it is positive it means that the energy produced by the ORC is greater than the needed for carrying the system on board, if it is negative then the amount of energy needed to carry the system on board is greater than the production of the ORC. For each curve there is a maximum mass flow of the organic fluid where it stops, this point refers to the last thermodynamically possible ORC system for that mass flow of cold air. In some cases a dramatic change in the direction of the curve will be seen, this corresponds to a change in the calculation method defined by the stream that has the highest heat flux rate, at the beginning is the air but as the as the organic fluid increases its mass flow, a point is reached where both fluids have the same heat transfer rate and then is the organic fluid the one with the highest heat transfer rate. This is only visible when the ORC is before the precooler without superheating.

In figure 6-10 is plotted the energy generated when the system is placed before the precooler and there is superheating, in this graph is shown the highest amount of energy produced. In the next graph (figure 6-11) the ORC before the precooler without superheating is represented, in this graph the change of direction because of heat transfer rates is seen when the cold fluid has a mass flow of 3.5 kg/s and 4 kg/s. The other two figures (6-12 and 6-13) are the graphs corresponding to the scenario when the system is placed before the AC Packs with and without superheating respectively. It is clear that in this case there is no saved energy because all the possible ORCs are below zero.

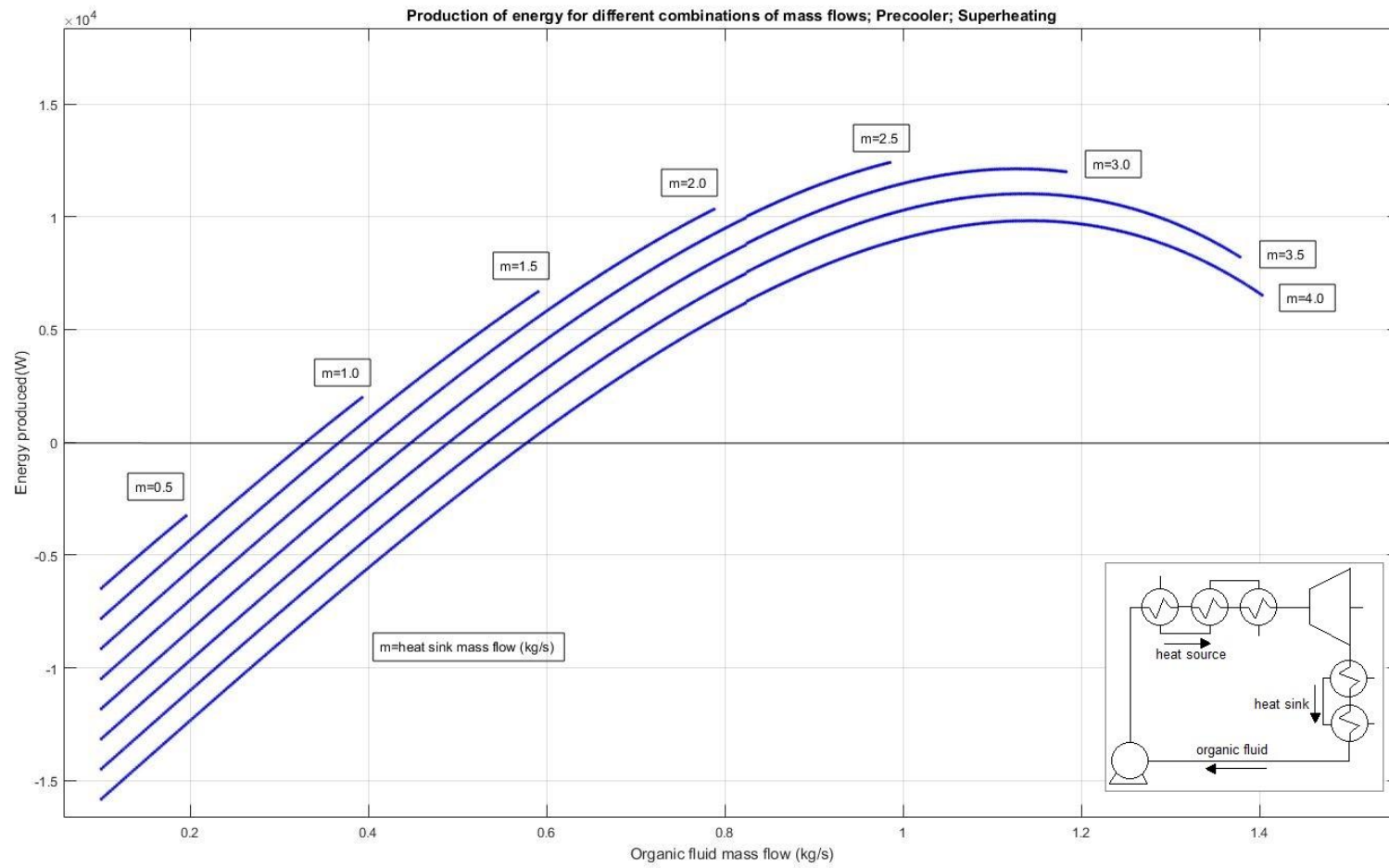

Figure 6-10: Energy generated for different mass flows of the organic fluid and cold air, system A.

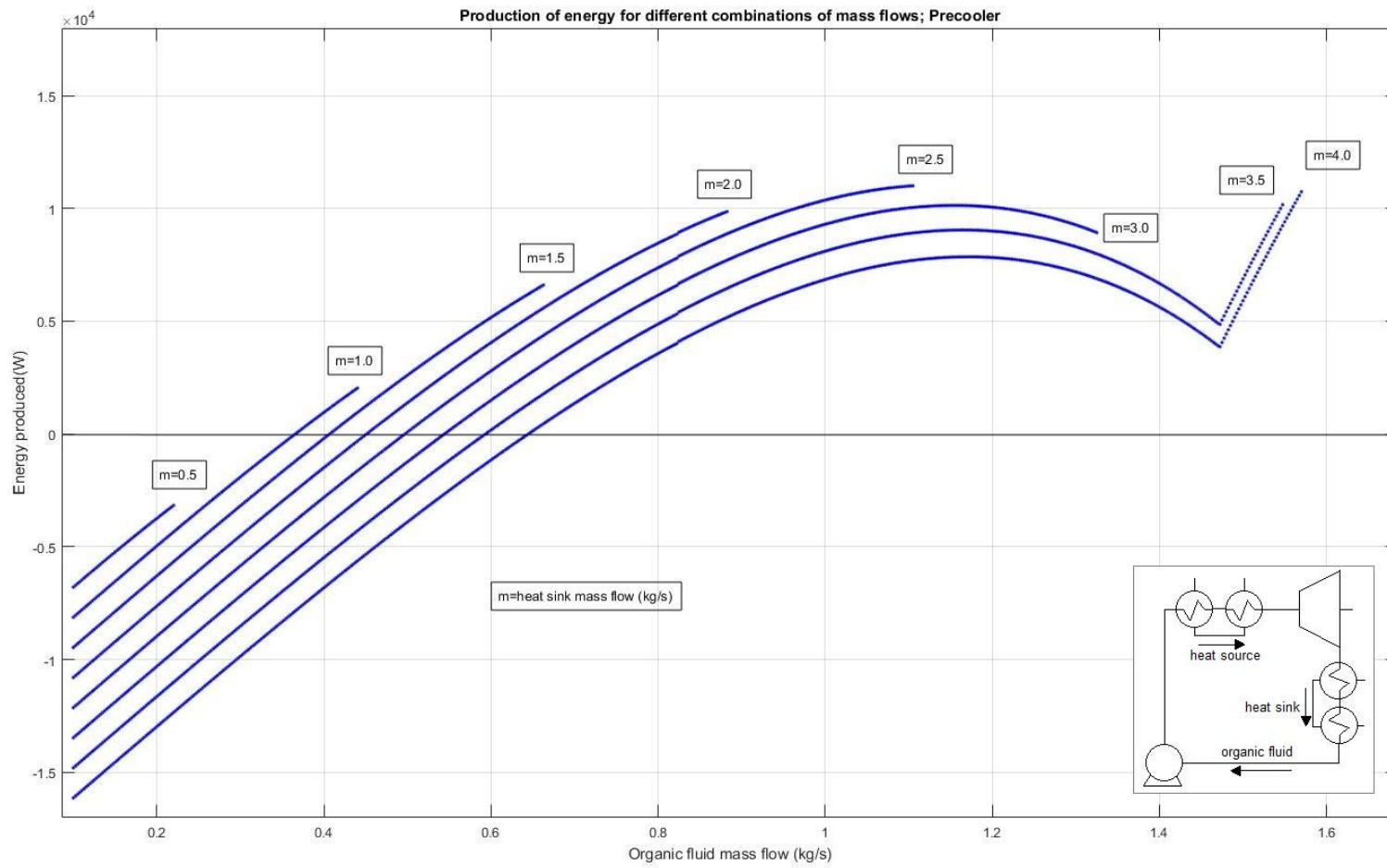

Figure 6-11: Energy generated for different mass flows of the organic fluid and cold air, system C.

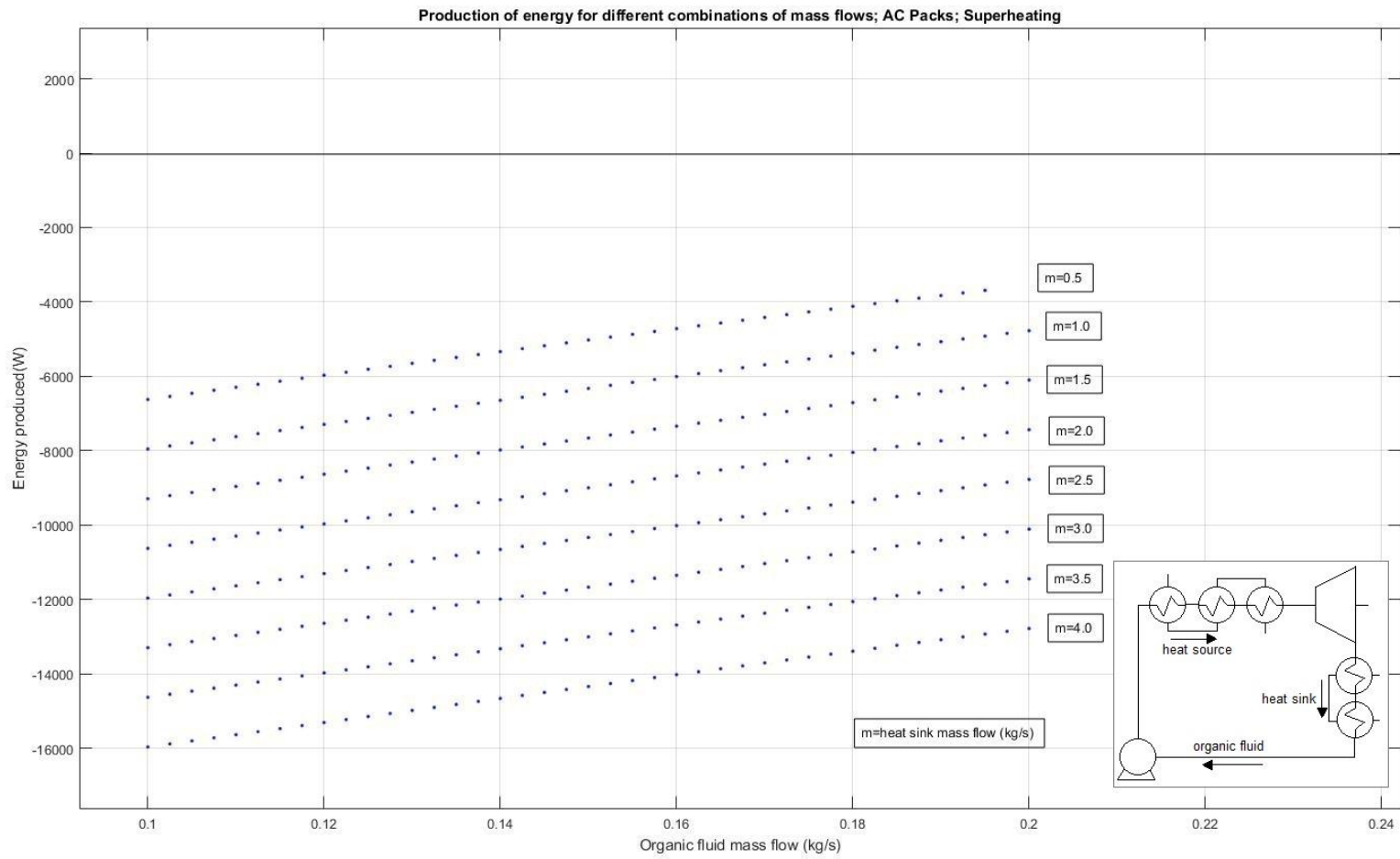

Figure 6-5: Energy generated for different mass flows of the organic fluid and cold air, system B.

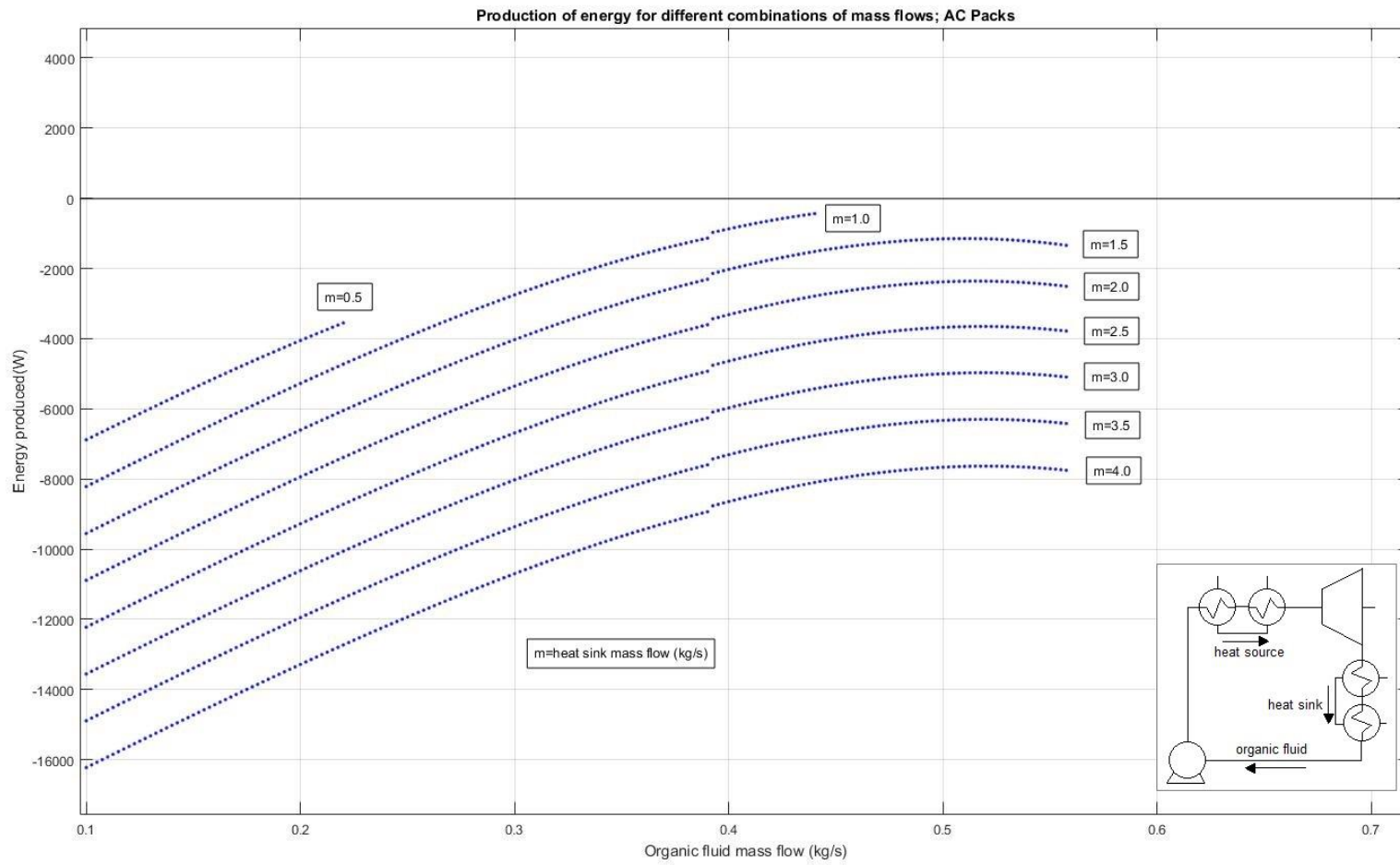

Figure 6-6: Energy generated for different mass flows of the organic fluid and cold air, system D.

6.3 Evaluation of the results

The heat energy available before the AC Packs corresponds to a fraction of the amount provided in the precooler. The conditions are appropriate to place an ORC in that location but the production of energy is not enough compared to the weight of it. The lowest difference, when the mass flow of the cold air is equal to 1 kg/s, is still a large value far from the limit of 0 (see figure), after which the production of saved energy is initiated. In the case where the ORC does not have an extra heater the situation is even farther from the limit. This put in evidence that the application of an ORC before the AC is not viable with off the shelf design and components.

6.4 Comparison with other ideas

The results obtained can be compared with the works from Perullo [8] and De Servi [6], both aim to place the ORC in the engine during cruise conditions and take waste heat from there for different purposes; the results and conclusions of these works will be discussed and compared, with the ones of this project, in this section. On one side the wasted heat from the engine is a high source of energy but changing the configuration of the engine for recovering this heat is an obstacle to achieve that goal.

In Perullo's work, the purpose is to use the energy recovered from the engine to produce an electric Environmental Control System, this will mean that no more air will be extracted from the engine so it will work more efficiently. The impacts on the engine are factor that are not taken into account and that need to be assessed to get the entire picture of the situation. Although the extraction of energy is successful and the heat source could provide a lot of energy, the work needs a wider picture of the problem. It is difficult to take into account and at the same time all the factors involved but it can be said from the work of Perullo that enough heat energy is disposable to be recovered and that the technique of getting it needs to be perfected.

In another attempt of getting more energy from the fuel, Servi et al. developed an ORC that is integrated in the engine, this system was presented in the literature review, as the one from Perullo, for being used in a GE 90-94B during cruise conditions. This engine is mainly used in the Boeing 777. The use of super critical CO₂ increases the amount of energy that can be recovered from the engine but for these amounts of energy a great amount of area is needed, which translates in the size of the heat exchangers. The cooler in this case, has a weight of 1,608 kg, a regenerator that weights 920 kg and a heater of 692 kg. For Servi's project there is also a recover of heat but the invasion of the engine and the amount of weight doesn't give a clear picture of the situation. This work shows a decrease of the SFC in 2.8%, but as the work from Perullo, the authors give a partial view of the scenario.

These two studies, as this work, aim to assess the potential of the idea of the integration of an ORC, even though they are placed in different areas and the energy outputs are different, there are many points (listed below) where the three works agree:

- There are areas in the aircraft where wasted heat can be recovered: engine, AC Packs and Precooler.
- The available cooling flows represent a chance to recover wasted heat with an ORC.
- The amount of energy that can be recovered from these sources of energy is enough to be taken into consideration for different possible applications in the aircraft, i.e. electric Environmental Control System, electronic components, lights and televisions.
- The materials and components for the ORC require being specifically for this application, since it is not easy to find them in the market, off the shelf designs were needed for this application.

There is a wide range of conditions available in the ECS to be assessed for the recovery of wasted heat. Only in the case of locating the ORC before the precooler is when considerable amounts of energy can be saved, and if a second heat exchanger is used to

superheat the organic fluid, then a more efficient system can be achieved for saving more energy. In the case of the ORC assessed before the AC Packs, the results show that the amount of energy produced in both cases (with and without superheating) is not enough to save energy on board, under certain conditions the results get very close from the limit where which the production of saved energy starts but this boundary is not crossed using this place for the ORC. The possible systems in this location are very less compared with the ones from the ORC before the precooler. In the case of the systems placed before the precooler the results show that the recovery of wasted energy is possible for many different combinations of parameters because the conditions are good enough for it.

Chapter 7 Conclusions

The results of this work have shown that the amount of heat that is released to the atmosphere as waste heat from the bleed air represents an opportunity to place a waste heat recovery system on board. It is therefore, possible to place an ORC in other places rather than the engine, where many penalties have to be paid. The two options analysed here (conditions in the precooler and in the air conditioning system) were evaluated, and the results show that both systems can work with the existing conditions but only the precooler provides a potential source of saved energy. A lightweight pump, turbo generator and the lightest materials for the design of the heat exchangers were chosen to integrate the system, checking that they were available on the market. The calculation method was used to size the heat exchangers but this does not mean that they can be found or that can be produced easily. According to Kays and London [21] the procedure gives the necessary size for the heat exchange needs, but their physical construction may involve changes in the design. The temperature of the bleed air varies with the outside conditions and the needs in the cabin. In the real scenario, this dynamic system has to adapt to the circumstances and with this, the production of energy would be also dynamic; the control and optimization of this case for finding the best conditions is recommended for further studies on this area. Some considerations have to be taken into account like the novelty of this application and the existence of a few number of works related to this; but although these situations the results presented show agreement with the real scenarios.

General conclusions from this work:

- A heat exchanger design and an ORC assessment tool were developed on MATLAB for this project.

- This tool was validated against other ORC calculations in different and similar scenarios and found to be good.
- The case study of an A320 in cruise conditions was selected and two sources of waste heat were identified.
- A large number of ORC designs were considered to show that an ORC before the precooler can save energy while an ORC placed before the AC Packs cannot provide enough work output to save energy.

Overall the idea has merit and the next steps should be:

- Accurate weight estimates.
- How to reduce weight.
- Investigate integration of the system into the aircraft.

Appendix

Flow diagram of thermodynamic ORC without superheating	73
Flow diagram of thermodynamic ORC without superheating	74
Links access the MATLAB code online	75

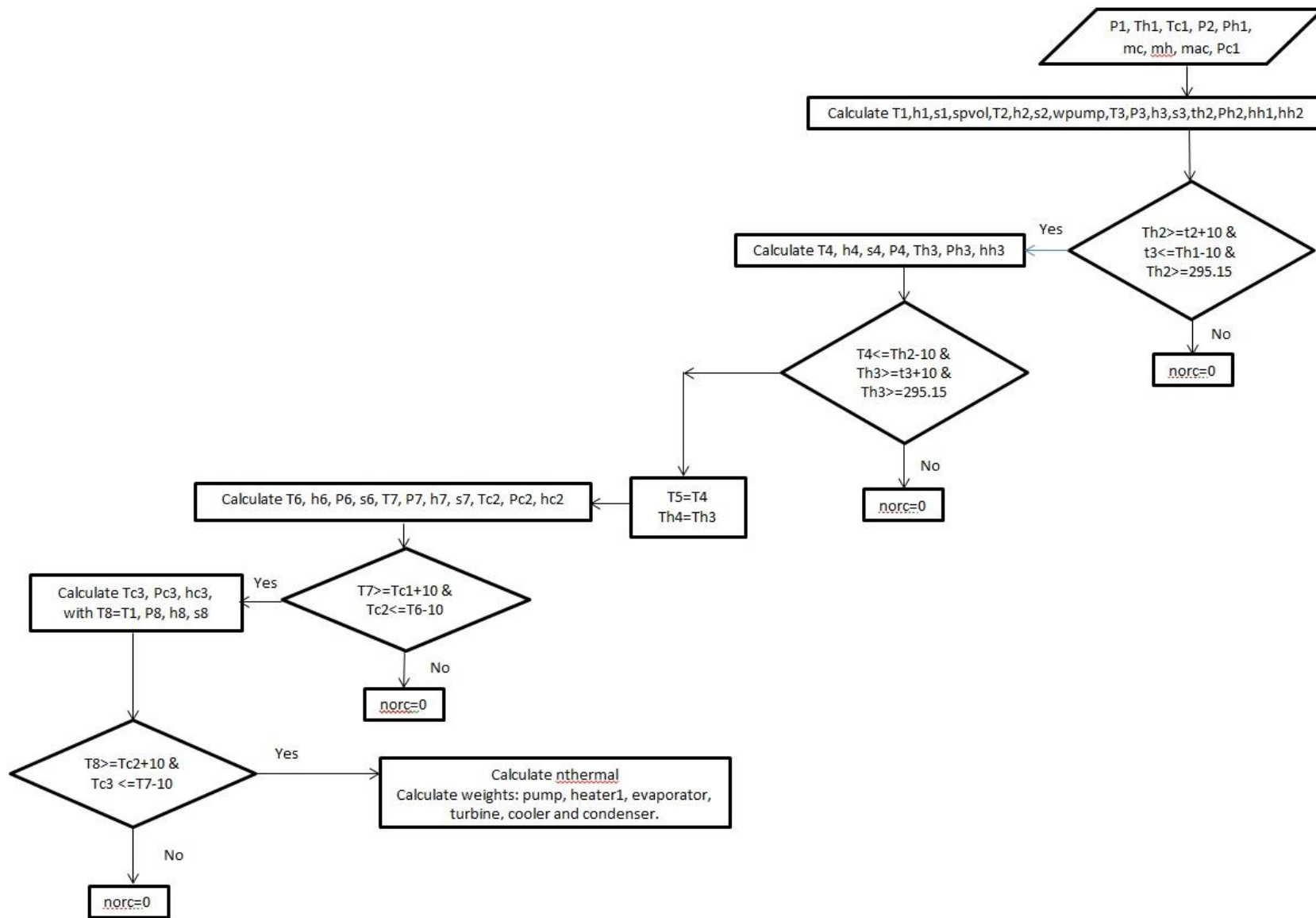

Figure A-0-1: Diagram for elemental ORC.

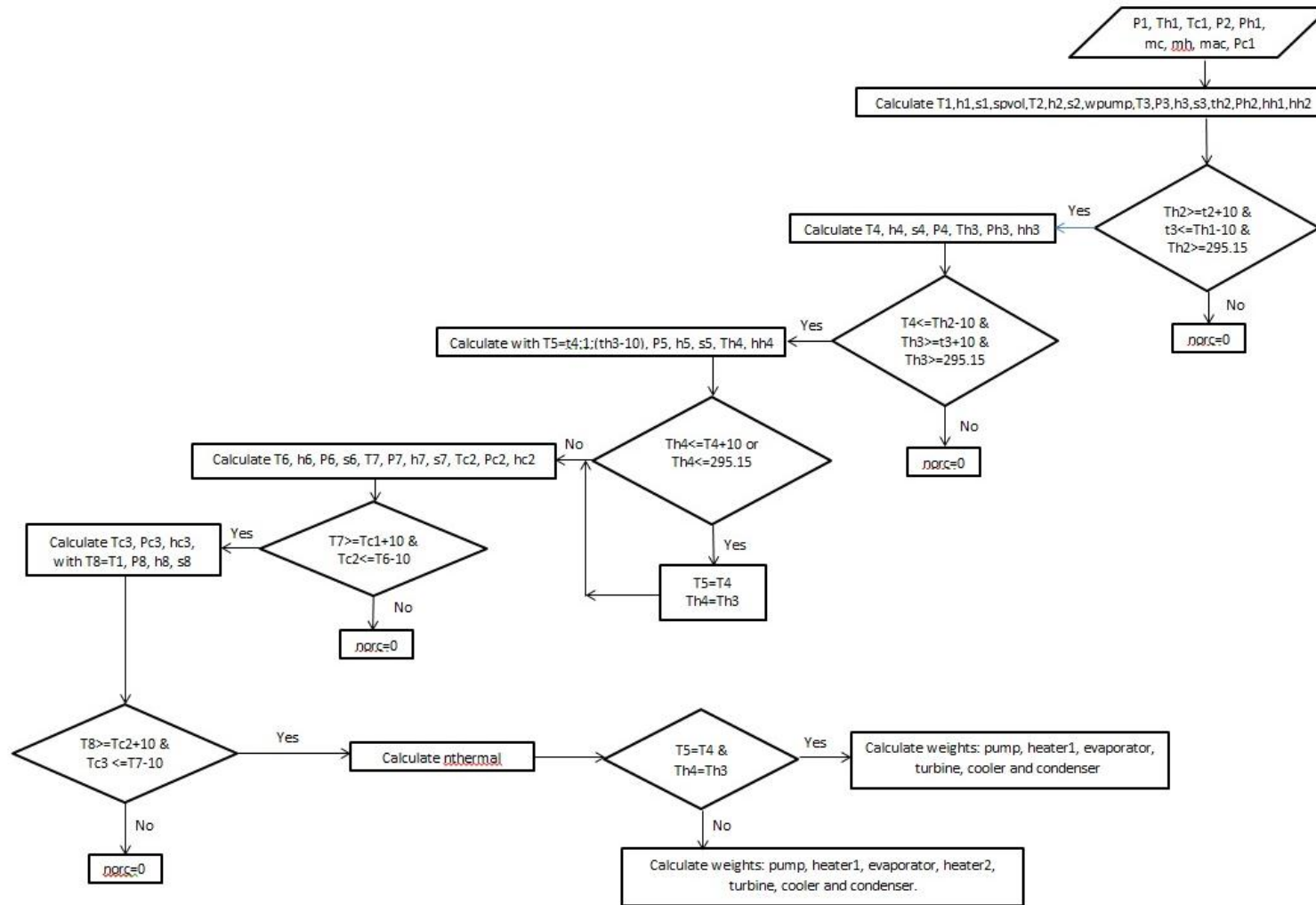

Figure A-0-2: Diagram of ORC with superheating.

Link

In the link below a folder can be found with the codes used in this work. There are ten MATLAB codes described below:

<https://drive.google.com/drive/folders/11iuClaW0WLzHmOLbpYXsZ1rcPUeTGKzW?usp=sharing>

Codes for calculating the mass of each component in the system:

- condenser.m
- cooler.m
- evaporator.m
- heater1.m
- heater2.m

Codes for calculating the thermodynamic parameters for every ORC:

- ORCthnoh.m: ORC with no superheating.
- ORCtf.m: ORC with superheating.

Codes for producing diagrams with parameters displayed on them:

- rankine_cycle.m: ORC with no superheating.
- rankine_cycleh.m: ORC with superheating.

References

1. S.A.S, A., *Mapping Demand 2016/2035*, ed. G.M. Forecast. 2016, Blagnac Cedex, France: Airbus S.A.S. 124.
2. Kerr, R.A., *Peak Oil Production May Already Be Here*. *Science*, 2011. **331**(6024): p. 1510.
3. Khandelwal, B., et al., *Hydrogen powered aircraft : The future of air transport*. *Progress in Aerospace Sciences*, 2013. **60**(Supplement C): p. 45-59.
4. Bala, D.D. and D. Chidambaram, *Production of renewable aviation fuel range alkanes from algae oil*. *RSC Advances*, 2016. **6**(18): p. 14626-14634.
5. Saadon, S. and A.R.A. Talib, *An analytical study on the performance of the organic Rankine cycle for turbofan engine exhaust heat recovery*. *IOP Conference Series: Materials Science and Engineering*, 2016. **152**(1): p. 012011.
6. De Servi, C., et al., *GPPF-2017-78 EXPLORATORY ASSESSMENT OF A COMBINED-CYCLE ENGINE CONCEPT FOR AIRCRAFT PROPULSION -DRAFT*. Global Power et propulsion society. 2017.
7. Rosebro, J. *Honda Researching Advanced Hybrid Drive with Rankine Cycle Co-Generation*. 2008 2017 [cited 2017; Available from: <http://www.greencarcongress.com/2008/02/honda-researchi.html>].
8. Perullo, C.A., D.N. Mavris, and E. Fonseca, *An Integrated Assessment of an Organic Rankine Cycle Concept for Use in Onboard Aircraft Power Generation*. 2013(55133): p. V002T01A028.
9. Bianchi, G., *Exhaust Waste Heat Recovery in Internal Combustion Engines*. 2015.
10. Berg, F.T.N., *Principles for aircraft exergy mapping*, in *Departments of Mechanical and Electrical Engineering*. 2013, University of Bath. p. 209.
11. Auld, A., A. Berson, and S.I. Hogg, *Organic Rankine cycles in waste heat recovery : a comparative study*. *International journal of low-carbon technologies*, 2013, Vol.8(Supplement 1), pp.9-18 [Peer Reviewed Journal], 2013.
12. Fang, H., et al., *Industrial waste heat utilization for low temperature district heating*. *Energy Policy*, 2013. **62**: p. 236-246.
13. Al., I.C.K.e., *Innovative waste heat recovery systems in rotorcrafts*, in *IEEE*. 2012: Bologna, Italy. p. 4.
14. Martinez, I. *Aircraft Environmental Control*. 2016 17/10/2017]; Available from: <http://webserver.dmt.upm.es/~isidoro/>.
15. S. Pasini, I.G., R. Andriani, L.D.A. Ferri, *Heat recovery from aircraft engines*, in *Energy Conversion Engineering Conference and Exhibit, 2000. (IECEC) 35th Intersociety*. 2000, IEEE: Las Vegas, NV, USA. p. 8.

16. Sinnett, M., *787 no-bleed systems: saving fuel and enhancing operational efficiencies*. AERO, 2008. **4**.
17. Elwood H. Hunt, D.D.H.R., David Space, Dr. Fred E. Tilton, *Commercial Airliner Environmental Control System*. Engineering Aspects of Cabin Air Quality, 1995: p. 8.
18. Engines, S.A. *The CFM56 success story*. 2017 [cited 2017 30/10]; Available from: <https://www.safran-aircraft-engines.com/commercial-engines/single-aisle-commercial-jets/cfm56/cfm56-5b>.
19. Agency, E.A.S., *Type-Certificate Data Sheet*. 2016, EASE: France. p. 23.
20. Yu, H., X. Feng, and Y. Wang, *Working Fluid Selection for Organic Rankine Cycle (ORC) Considering the Characteristics of Waste Heat Sources*. Industrial and Engineering Chemistry Research, 2016. **55**(5): p. 1309-1321.
21. Kays, L., *Compact heat exchangers*. Third Edition ed. 1998, USA: krieger publishing company. 335.
22. Bao, J. and L. Zhao, *A review of working fluid and expander selections for organic Rankine cycle*. Renewable and Sustainable Energy Reviews, 2013. **24**: p. 325-342.
23. *Compact heat exchangers: Basic information*. Types of Compact Heat Exchangers 2017; Available from: http://fchart.com/ees/heat_transfer_library/compact_hx/hs100.htm.
24. CasconInc. *R134a Liquid Refrigerant Pump for 2-Phase Liquid Refrigerant System*. 2014 09/10/2017]; Available from: <https://www.casconpump.com/product/2-phase-liquid-refrigerant-cooling-system/>.
25. *2V-72V 200mm 8.5kW/14kW light weight pancake PM motors*. 2017; Available from: http://www.everything-ev.com/index.php?main_page=product_info&cPath=65_77_96&products_id=288.
26. Kang, S.H., *Design and experimental study of ORC (organic Rankine cycle) and radial turbine using R245fa working fluid*. Energy, 2012. **41**(1): p. 514-524.
27. Nicholas Cumpsty, A.H., *Jet Propulsion A simple guide to the aerodynamics and thermodynamic design and performance of jet engines*. 2015, New York: Cambridge University Press. 353.
28. Meier, N. *Civil Turbojet/Turbofan Specifications*. 2005 03 April 2005 18/10/2017]; Available from: <http://www.jet-engine.net/civtfspec.html>.
29. Pilots, P. *Tech Log Forum*. 2008 [cited 2017; Available from: <http://www.pprune.org/tech-log/319851-lift-drag-ratio-a320.html>.
30. Martinez, I. *Fuel properties*. 2017; Available from: <http://webserver.dmt.upm.es/~isidoro/bk3/c15/Fuel%20properties.pdf>.
31. Kantor, J. *Understanding Heat Exchangers- Cross-flow, Counter-flow (Rotary/Wheel) and Cross-counter-flow Heat Exchangers*. 2014; Available from: <http://info.zehnderamerica.com/blog/understanding-heat-exchangers-cross-flow-counter-flow-rotarywheel-and-cross-counter-flow-heat-exchangers>.
32. Ramesh K. Shah, D.P.S., *Fundamentals of Heat exchanger Design*. 1st edition ed. 2003, Canada: John Wiley & Sons, Inc. 941.

33. Hewitt, G.F., *Hemisphere Handbook of Heat Exchanger Design*. 1990, United States of America: Hemisphere publishing corporation.
34. Team, I.H.B.a.t.C. *CoolProp*. 2016 [cited 2017; Available from: <http://www.coolprop.org/index.html#>].
35. ASIMPTOTE. *ASIMPTOTE*. [cited 2017; Available from: <http://www.asimptote.nl/>].
36. Aneke, M., B. Agnew, and C. Underwood, *Performance analysis of the Chena binary geothermal power plant*. *Applied Thermal Engineering*, 2011. **31**(10): p. 1825-1832.
37. Airbus, *Flight crew operation manual*. A320 Simulator. Airbus Training.
38. Liebherr-aerospace, *A319/A320/A321 Environmental Control System*. Familiarization Training. 2004, Lindenberg: Liebherr. 162.
39. Integrated Publishing, I. *HEIGHTS TO STANDARD PRESSURE AND TEMPERATURE*. 2013; Available from: http://meteorologytraining.tpub.com/14269/css/14269_75.htm.
40. Rydock, J.P., *Air quality in passenger aircraft*. Ventilation Information Paper, 2008.
41. *airliners*. [d del airbus a 320]. Available from: <http://www.airliners.net/forum/viewtopic.php?t=763321>.
42. El-Sayed, A.F., *Aircraft Propulsion and Gas Turbine Engines*. Second ed. 2017: CRC Press.
43. Spray, *SF Pressure Drop Online-Calculator. Roughness of pipes*. Available from: https://www.spray.com/calculators/Pressure_Drop_Calc/rauh.html.
44. Engineers Edge, *Moody chart*. 2008; Available from: https://www.engineersedge.com/fluid_flow/pressure_drop/moody_chart.htm.