

Durham E-Theses

One and two loop phenomenology in heterotic string theory

RICHARD JOHNSTON STEWART

How to cite:

STEWART, RICHARD JOHNSTON (2017) One and two loop phenomenology in heterotic string theory. Doctoral thesis, Durham University.

Use policy

The full-text may be used and/or reproduced, and given to third parties in any format or medium, without prior permission or charge, for personal research or study, educational, or not-for-profit purposes provided that:

- a full bibliographic reference is made to the original source
- a <https://etheses.durham.ac.uk/id/eprint/12365/> is made to the metadata record in Durham E-Theses
- the full-text is not changed in any way

The full-text must not be sold in any format or medium without the formal permission of the copyright holders.

Please consult the [full Durham E-Theses policy](#) for further details.

One and two loop phenomenology in heterotic string theory

Richard Johnston Stewart

A Thesis presented for the degree of
Doctor of Philosophy



Centre for Particle Theory
Department of Mathematical Sciences
Durham University
United Kingdom

November 2017

One and two loop phenomenology in heterotic string theory

Richard Johnston Stewart

Submitted for the degree of Doctor of Philosophy

November 2017

Abstract: We examine the phenomenological properties of certain heterotic string theories through the computation of one and two-loop amplitudes.

Initially, we consider the fate of shift-symmetries in effective string models is considered beyond tree-level. Such symmetries have been proposed in the past as a way to maintain a hierarchically small Higgs mass and also play a role in schemes of cosmological relaxation. It is argued that on general grounds one expects shift-symmetries to be restored in the limit of certain asymmetric compactifications, to all orders in perturbation theory. This behaviour is verified by explicit computation of the Kähler potential to one-loop order.

We then turn to the two-loop cosmological constant in non-supersymmetric heterotic strings where two independent criteria are presented that together guarantee its exponential suppression. They are derived by performing calculations in both the full string theory and in its effective field theory, and come respectively from contributions that involve only physical untwisted states, and contributions that include orbifold twisted states. The criteria depend purely on the spectrum and charges, so a model that satisfies them will do so with no fine-tuning. An additional consistency condition (emerging from the so-called separating degeneration limit of the two-loop diagram) is that the one-loop cosmological constant must also be suppressed, by Bose-Fermi degeneracy in the massless spectrum. We

comment on the effects of the residual exponentially suppressed one-loop dilaton tadpole, with the conclusion that the remaining instability would be under perturbative control in a generic phenomenological construction. We remark that theories of this kind, that have continued exponential suppression to higher orders, can form the basis for a string implementation of the “naturalness without supersymmetry” idea.

Declaration

The work in this thesis is based on research carried out in the Centre for Particle Theory, Department of Mathematical Sciences, Durham University, United Kingdom. No part of this thesis has been submitted elsewhere for any other degree or qualification and it is all my own work unless referenced to the contrary in the text. Chapters 3 and 4 are original work, resulting from collaborations between Prof. Steven Abel and the author, appearing in:

- S. A. Abel and R. J. Stewart, “Shift-symmetries at Higher Order”, *JHEP* 1602 (2016), p. 182. arXiv: hep-th/1511.02880 [hep-th].
- S. A. Abel and R. J. Stewart, “The cosmological constant in non-SUSY strings at two loops and beyond”. arXiv: hep-th/1701.06629 [hep-th].

Copyright © November 2017 by Richard Johnston Stewart.

“The copyright of this thesis rests with the author. No quotations from it should be published without the author’s prior written consent and information derived from it should be acknowledged.”

Acknowledgements

This work was supported by an EPSRC studentship.

I would like to give thanks to my supervisor Prof. Steven Abel for his time and support for the duration of my PhD. His many ideas have proved invaluable in progressing with this research over the last few years.

I thank the friends I have shared an office with for almost four years and those elsewhere in the department at various stages during the entirety of my time in Durham. I would also like to thank the friends I have spent many great times with in Durham as a whole, and also to those back home in Belfast.

Finally, I have special thanks for my parents for their lifelong support.

Contents

Abstract	ii
List of Figures	ix
1 Background	1
2 String theory	7
2.1 Classical string theory	7
2.1.1 Bosonic string theory	7
2.1.2 Superstring theory	12
2.2 Quantisation	14
2.2.1 Canonical quantisation	14
2.2.2 BRST quantisation	16
2.2.3 The closed string spectrum	17
2.2.4 The GSO projection	18
2.2.5 The heterotic string	19
2.3 The one-loop partition function and modular invariance	20
2.3.1 The torus	20
2.3.2 The one-loop partition function	22
2.4 Compactification	24
2.4.1 Toroidal compactification	24
2.4.2 The \mathbb{Z}_2 orbifold	25
2.4.3 Wilson lines	27
2.5 Free fermionic models	28

2.5.1	Bosonisation	28
2.5.2	The construction of free fermionic models	29
2.5.3	Coordinate dependent compactification	31
2.6	String perturbation theory	36
2.6.1	The genus expansion	36
2.6.2	Vertex operators	37
2.7	Supergravity as an effective theory	40
3	Shift-symmetries at higher order	42
3.1	Introduction	42
3.2	The calculation	45
3.2.1	Moduli definitions, vertex operators and partition function	45
3.2.2	Two-point amplitudes	47
3.2.3	Modular integrals	49
3.3	One-loop Kähler potential	55
3.4	Restoration of shift-symmetry	56
4	The cosmological constant in non-SUSY strings at two loops and beyond	61
4.1	Introduction and conclusion	61
4.2	Two-loop amplitudes	65
4.2.1	The set-up in the ϑ -function formalism	65
4.2.2	The Scherk-Schwarz cosmological constant	69
4.2.3	The q -expansion of \aleph	74
4.2.4	Field theory factorization: identifying leading contributions	76
4.2.5	The separating degeneration limit	79
4.2.6	Comments on the effect of the one-loop tadpole	81
4.2.7	Suppression of the “mixed” diagrams	83
4.3	Conclusion	89
5	Summary	91

A	Jacobi theta functions	93
B	Two-loop theta functions and modular transformations	95
C	$SO(10)$ model with massless Bose-Fermi degeneracy	97
	C.1 Model definition, and vanishing of SUSY partition function	97
	C.2 Massless Bose-Fermi degeneracy and the 1-loop q -expansion	99
D	The two-loop cosmological constant	100
	D.1 The hyperelliptic formalism	100
	D.2 The two-loop cosmological constant in non-SUSY theories	101
	D.2.1 General result in the ϑ -function formalism	101
E	Evaluation of the massless contribution to the two-loop cosmo-	
	logical constant	105
	Bibliography	107

List of Figures

1.1	One-loop corrections to the Higgs mass.	2
2.1	A closed string sweeping out a worldsheet.	8
2.2	Torus as a quotient of the complex plane.	20
2.3	Fundamental domain.	21
2.4	The $\mathbb{T}_2/\mathbb{Z}_2$ orbifold.	26
2.5	Perturbative series expansion of the genus g	36
2.6	Map from cylinder to the complex plane.	38
2.7	One-loop 4-point scattering.	39
4.1	Canonical homology basis for genus 2.	66
4.2	Generic sunset diagram for the two-point function.	75
4.3	The Feynman diagrams for the two-loop cosmological constant in the effective $\mathcal{N} = 2$ field theory of the untwisted sector.	76
4.4	The separating degeneration limit.	80

Chapter 1

Background

The major developments in fundamental physical theories in the twentieth century came through general relativity (GR) which describes the force of gravitation through the geometric structure of spacetime, and quantum field theory (QFT) where particles arise as the excited states of a physical field. The theoretical study of QFT alongside experimental observation later culminated in the development of the standard model.

The standard model contains three generations of chiral leptons and quarks, describing all visible matter in the universe, along with gauge bosons which mediate the strong, weak and electromagnetic forces. The gauge group is $SU(3)_C \times SU(2)_L \times U(1)_Y$ above the electroweak scale, which is then broken through the Higgs mechanism, giving masses to the matter particles and to the W^\pm and Z gauge bosons. The standard model has proven to be highly consistent with experimental tests, most recently with the detection of the Higgs Boson at the LHC. Nevertheless it still suffers from a number of problems. These include the absence of a description of the gravitational force, the observed Higgs mass in relation to the hierarchy problem, and the seemingly ad hoc construction involving a large number of arbitrary numerical constants and a specific gauge group. Therefore, it seems that while the standard model certainly approximates the physical world to high precision, there are still areas of study beyond the standard model which need to be addressed.

One of the aforementioned problems in the standard model, the hierarchy problem, deals with the idea of naturalness, and the apparent need for the requirement of considerable fine-tuning of corrections to the Higgs mass in order for it to be so many orders of magnitude lower than the Planck mass. One proposed solution to this problem is supersymmetry, a symmetry relating bosons and fermions. This symmetry results in each elementary particle having an associated superpartner with equal mass but differing in spin by a factor of a half. If supersymmetry were exact above some intermediate scale, contributions from bosonic and fermionic loops would cancel exactly and so radiative corrections to the Higgs mass above this scale would be suppressed. The symmetry must necessarily be broken in order to account for the fact that the known standard model particles do not have observed superpartners of equal mass. However, no evidence for these supersymmetric particles has been found so far leading to some doubt into its existence.

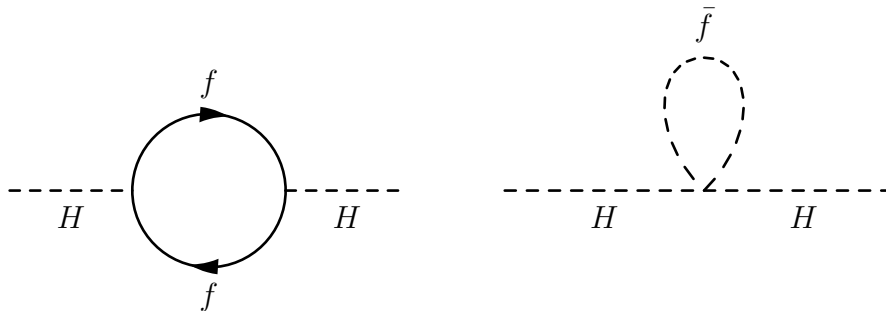

Figure 1.1: One-loop corrections to the Higgs mass.

Nevertheless, if we were continue with the assumption of the existence of supersymmetry in some form, we can consider what happens if we treat it as a local symmetry. The result is a field theory known as supergravity that contains a spin 2 field associated with the graviton, the force carrier for the gravitational force. One might hope that this could address one of the other issues of the standard model, the absence of a description of gravity. However, it is a well known fact that the theory of gravity as described by general relativity cannot be consistently formulated as a quantum field theory in the same way as the other three fundamental forces due to its non-renormalisability. At best, supergravity

could only serve as an effective field theory of some more complete theory at higher energies. Therefore, there is still considerable interest in formulating a correct description of quantum gravity in order to have a single unified theory.

One of the most studied candidates for quantum gravity is string theory, in which the concept of point particles appearing in QFT are replaced by one-dimensional extended strings, which trace out a two-dimensional worldsheet in target space. The usual elementary particles in the standard model should then correspond to particular vibration modes of these strings. In fact the graviton naturally emerges as a quantum vibration of the relativistic string, and so in some sense string theory predicts gravity, rather than having to insert it by hand.

The simplest construction of string theory, the bosonic string, provides a useful introduction into the basic concepts of the theory, and requires 26 spacetime dimensions for anomaly cancellation. However, these theories contain physical tachyons in the spectrum and do not have spacetime fermions, leaving them phenomenologically unappealing. Both of these issues may be dealt with by considering superstring theories, which can be constructed by adding supersymmetry to the worldsheet. The most studied theories are those for which supersymmetry is then extended into the target space, due to their stability. Superstring theories require 10 spacetime dimensions and so some process is required to match these theories with the four-dimensional universe we observe. One method of doing so is by compactifying the extra six dimensions on some 6D manifold. This has the added advantage of allowing for control over breaking the gauge group, ideally to one that contains that of the standard model, while also affecting the number of spacetime supersymmetries present.

Superstring theory has several different descriptions which are all related to each other through a set of dualities. They are the Type I, IIA, IIB and the $SO(32)$ and $E_8 \times E_8$ heterotic strings. The heterotic $E_8 \times E_8$ theories have been the traditional preference for phenomenology since they tend to lead to smaller gauge groups in the simplest compactifications. They are theories of closed strings only, for which the left and right moving sides are independently taken to be that

of a bosonic string and superstring respectively. The result is a ten-dimensional theory where the extra degrees of freedom on the bosonic side form the $E_8 \times E_8$ gauge group. The gauge group can then be broken as one compactifies down to four dimensions, with the appealing property that the gauge group of the standard model fits easily into E_8 through the embeddings

$$SU(3) \times SU(2) \times U(1) \subset SU(5) \subset SO(10) \subset E_6 \subset E_7 \subset E_8. \quad (1.1)$$

In order to attempt to relate string models to physical observations, we are often only interested in looking at the theory at large distance scales. We then study the properties of this low energy effective theory which usually appears as some supergravity theory. Computations carried out in the full string theory can then provide the precise structure of the supergravity theory. Considerable effort has been made to demonstrate that it is indeed possible that the standard model appears as the low-energy effective theory of some particular string model. There are certainly examples of string models which contain the standard model gauge group along with some hidden sector and also contain three generations of chiral fermions. Nevertheless, even if string theory turns out not to be a true fundamental theory itself, its study may still provide useful insight into how a true theory of quantum gravity might behave.

If superpartners of the standard model particles were to be detected, it would seem natural to consider some superstring theory which contained the SM gauge group, work with its low-energy effective theory and apply field theoretic supersymmetry breaking techniques to try and find agreement with physical observations. However, the non-detection of such superpartners has lead to interest in superstring theories where supersymmetry is not broken at some low-energy scale in the effective theory, but it is broken in the string theory itself by its very construction. One of the greatest problems with these models is a generically large value of the cosmological constant. In superstring theories with unbroken spacetime supersymmetry, there are guaranteed to be an equal number of bosons and fermions at each mass level. This leaves the one-loop cosmological constant

trivially equal to zero since bosons and fermions contribute to the loop with opposite signs, while higher loop contributions are also known to vanish. It is an area of ongoing research to find whether there exist non-supersymmetric string theories where the value cosmological constant is, if not identically zero, at least exponentially suppressed.

Much like when studying quantum field theories, one can learn a good deal about string theories, and their effective field theories, through the use of perturbation theory. In QFT one can consider a loop expansion of Feynman diagrams and similarly in string theory one can work with a genus expansion of super Riemann surfaces. The evaluation of amplitudes in this way in string theory is potentially much more efficient than in QFT. The reason is that a single diagram in string theory will usually contain many different Feynman diagrams. However, in general the techniques to evaluate string amplitudes in this way are not as fully developed as their counterparts in QFT. At tree and one-loop level in string theory the difference between Riemann surfaces and super Riemann surfaces is immaterial and so the evaluation of such processes is much simpler than those of higher genus. The evaluation of one-loop amplitudes involves the insertion of vertex operators corresponding to external states, and integrating over all physically distinct surfaces. An additional benefit of computations in string theory is that the integrals result in the absence of UV divergences entirely.

Further difficulties arise in the study of higher genus amplitudes. Beyond one-loop order, the distinction between Riemann surfaces and super Riemann surfaces is critical. The surface is not only described by moduli, but also by super moduli which need to be integrated out. At two-loop order the three moduli are assigned to the three independent components of the super period matrix, and after integration over the odd supermoduli, one is left with an expression involving only integrals over the even bosonic moduli only. Going beyond two-loop order results in further complications still, which may require adaptations to the methods developed at two-loop.

The layout of this thesis is as follows. In chapter 2, we begin with an in-

introduction to string theory and related phenomenological properties. We then proceed in chapter 3 to consider the low energy effective theories of a class of heterotic string models with non-vanishing Wilson lines where the compactification includes a factor of a \mathbb{T}_2 torus. The tree-level Kähler potential of these theories exhibits a shift symmetry relating to the Wilson lines. We compute one-loop perturbative amplitudes to determine one-loop corrections to the Kähler potential, allowing us to test whether the shift-symmetry holds to higher orders. In chapter 4 we study the cosmological constant in non-supersymmetric string models beyond one-loop order. We determine that the dominant contributions come from the massless states, while all others are exponentially suppressed. We analyze the contributions coming from both the untwisted and twisted sectors separately, by both computing the q -expansions for individual models in the full string theory, and by computing contributions from Feynman diagrams in the effective field theory. We discuss what conditions on the massless spectrum need to be satisfied to give an exponentially suppressed cosmological constant.

Chapter 2

String theory

This chapter provides a brief review into several aspects of string theory that are relevant to the subsequent chapters. The main references are [1–6].

2.1 Classical string theory

2.1.1 Bosonic string theory

The starting point of string theory is to replace the QFT notion of point particles by extended 1-dimensional objects which propagate in D -dimensional spacetime. Whilst a point particle can be thought to trace out a worldline as it propagates in spacetime, a classical string traces out a 2-dimensional worldsheet embedded in the D -dimensional target space as depicted in Figure 2.1. The worldsheet is parametrised by one time-like coordinate τ and one space-like coordinate σ , and spacetime is subsequently given by a set of D fields $X^\mu(\tau, \sigma)$ on the worldsheet, where the index μ denotes the spacetime dimension. We will come to see that the vibration modes of these fields correspond to different types of elementary particles. The action of the string should be independent of the choice of coordinates τ and σ while the area of the worldsheet should also be minimised. This leads to the Nambu-Goto action

$$S_{NG} = -T \int d^2\sigma \sqrt{-h}, \quad (2.1.1)$$

where $d^2\sigma \equiv d\tau d\sigma$, $h = \det h_{ab}$ and the induced metric $h_{ab} = \eta_{\mu\nu} \partial_a X^\mu \partial_b X^\nu$ is the pull-back of the Minkowski metric $\eta_{\mu\nu}$ onto the worldsheet. The constant $T = \frac{1}{2\pi\alpha'}$, where α' is the Regge slope, is the tension of string and its presence keeps the action dimensionless.

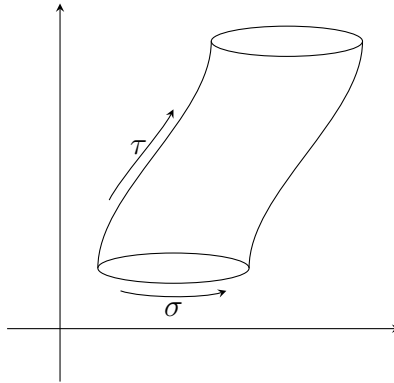

Figure 2.1: A closed string sweeping out a worldsheet.

The Nambu-Goto action has two types of symmetry:

- Poincaré invariance, a global symmetry under which the worldsheet fields transforms as

$$X^\mu \rightarrow \Lambda^\mu_\nu X^\nu + a^\mu. \quad (2.1.2)$$

- Reparametrisation (or diffeomorphism) invariance, a local symmetry for which the action is invariant under

$$X^\mu(\tau, \sigma) \rightarrow X'^\mu(\tau', \sigma'), \quad (2.1.3)$$

for a change of coordinates to $\tau'(\tau, \sigma)$ and $\sigma'(\tau, \sigma)$.

The equations of motion for the Nambu-Goto string are

$$\partial_a \left(\sqrt{-h} h^{ab} \partial_b X^\mu \right) = 0. \quad (2.1.4)$$

However, the Nambu-Goto action is difficult to work with due to the square root. Instead, we can introduce an independent worldsheet metric $g_{ab}(\tau, \sigma)$ to obtain the classically equivalent Polyakov action

$$S_P = -\frac{T}{2} \int d^2\sigma \sqrt{-g} g^{ab} h_{ab}, \quad (2.1.5)$$

where $g = \det g_{ab}$. This action is classically equivalent to the Nambu-Goto action and from the worldsheet perspective it describes a number of scalar fields coupled to 2d gravity. In addition to the Poincaré and reparametrisation invariance present in the Nambu-Goto action, the Polyakov action has an extra symmetry:

- Weyl invariance, a local symmetry where $X^\mu(\tau, \sigma) \rightarrow X^\mu(\tau, \sigma)$ while the metric changes as

$$g_{ab}(\tau, \sigma) \rightarrow \Omega^2(\tau, \sigma)g_{ab}(\tau, \sigma). \quad (2.1.6)$$

The equations of motion for X^μ are again given by

$$\partial_a \left(\sqrt{-g} g^{ab} \partial_b X^\mu \right) = 0, \quad (2.1.7)$$

but the metric g_{ab} is now fixed by its own equation of motion giving, up to a factor,

$$g_{ab} = \partial_a X^\mu \partial_b X_\mu. \quad (2.1.8)$$

In order to simplify the equations of motion, we may choose a gauge based on the freedom provided by both the reparametrisation and Weyl invariance. Together they allow us to set the worldsheet metric to be the flat metric in Minkowski coordinates, $g_{ab} = \eta_{ab}$, which is referred to as the conformal gauge. With this choice the Polyakov action simplifies to

$$S_P = -\frac{T}{2} \int d^2\sigma \partial_a X^\mu \partial^a X_\mu, \quad (2.1.9)$$

describing a theory of D free scalar fields, while the equations of motion for X^μ simplify to give the free wave equation

$$\partial_a \partial^a X^\mu = 0. \quad (2.1.10)$$

Of course we still need to take into account the equations of motion for the metric g_{ab} . To do so we consider the variation of the action with respect to the metric, which gives rise to the stress-energy tensor T_{ab} , defined as

$$T_{ab} = -\frac{2}{T} \frac{1}{\sqrt{-g}} \frac{\partial S_P}{\partial g^{ab}}. \quad (2.1.11)$$

Setting $g_{ab} = \eta_{ab}$ as before gives

$$T_{ab} = \partial_a X^\mu \partial_b X_\mu - \frac{1}{2} \eta_{ab} \eta^{cd} \partial_c X^\mu \partial_d X_\mu. \quad (2.1.12)$$

The equation of motion for the metric g_{ab} is just the condition that the energy-momentum tensor vanishes, $T_{ab} = 0$. Overall the equations of motion of the string are simply the free wave equations subject to the constraint $T_{ab} = 0$. Explicitly the constraints from the stress-energy tensor give

$$\dot{X} \cdot X' = 0, \quad (2.1.13)$$

$$\dot{X}^2 + X'^2 = 0, \quad (2.1.14)$$

where $\dot{X} \equiv \partial_\tau X(\tau, \sigma)$ and $X' \equiv \partial_\sigma X(\tau, \sigma)$. These are known as the Virasoro constraints. Defining the worldsheet light-cone coordinates as $\sigma^\pm = \tau \pm \sigma$ and similarly $\partial_\pm = \frac{1}{2}(\partial_\tau \pm \partial_\sigma)$, while $\eta_{++} = \eta_{--} = 0$, $\eta_{+-} = \eta_{-+} = -\frac{1}{2}$, we can rewrite the equations of motion for X^μ as

$$\partial_+ \partial_- X^\mu = 0. \quad (2.1.15)$$

Specifying to the case of closed strings, we need a solution to the equations of motion that satisfies the periodicity condition

$$X^\mu(\tau, \sigma + 2\pi) = X^\mu(\tau, \sigma). \quad (2.1.16)$$

A general solution to the equations of motion can be separated into a left and right-moving part

$$X^\mu(\tau, \sigma) = X_L^\mu(\sigma^+) + X_R^\mu(\sigma^-), \quad (2.1.17)$$

where X_L^μ and X_R^μ can be expanded into modes

$$\begin{aligned} X_L^\mu(\sigma^+) &= \frac{x^\mu}{2} + \frac{\alpha'}{2} p^\mu \sigma^+ + i \sqrt{\frac{\alpha'}{2}} \sum_{n \neq 0} \frac{\tilde{\alpha}_n^\mu}{n} e^{-in\sigma^+}, \\ X_R^\mu(\sigma^-) &= \frac{x^\mu}{2} + \frac{\alpha'}{2} p^\mu \sigma^- + i \sqrt{\frac{\alpha'}{2}} \sum_{n \neq 0} \frac{\alpha_n^\mu}{n} e^{-in\sigma^-}, \end{aligned} \quad (2.1.18)$$

where the variables x^μ and p^μ are the centre of mass position and total momentum

of the string respectively.

The vanishing of the energy-momentum tensor now takes the form

$$\begin{aligned} T_{++} &= \partial_+ X^\mu \partial_+ X_\mu = 0, \\ T_{--} &= \partial_- X^\mu \partial_- X_\mu = 0, \end{aligned} \tag{2.1.19}$$

while the vanishing of the trace is expressed through $T_{+-} = T_{-+} = 0$. The mode expansions of the energy-momentum tensor are

$$T_{--} = 2\alpha' \sum_{m=-\infty}^{\infty} L_m e^{-2im\sigma^-}, \quad T_{++} = 2\alpha' \sum_{m=-\infty}^{\infty} \tilde{L}_m e^{-2im\sigma^+} \tag{2.1.20}$$

where the modes are also known as the Virasoro generators and are given by

$$L_m = \frac{1}{2} \sum_{n=-\infty}^{\infty} \alpha_{m-n} \alpha_n, \quad \tilde{L}_m = \frac{1}{2} \sum_{n=-\infty}^{\infty} \tilde{\alpha}_{m-n} \tilde{\alpha}_n. \tag{2.1.21}$$

The Hamiltonian is given by the sum of the two zero modes of the Virasoro generators

$$H = 2 \left(L_0 + \tilde{L}_0 \right) = \sum_{n=-\infty}^{\infty} (\alpha_{-n} \alpha_n + \tilde{\alpha}_{-n} \tilde{\alpha}_n). \tag{2.1.22}$$

The vanishing of the energy-momentum tensor implies the vanishing of all Fourier modes $L_m = 0 \forall m \in \mathbb{Z}$. An expression for the mass of the string can be derived from the classical constraint

$$L_0 = \tilde{L}_0 = 0, \tag{2.1.23}$$

and so for the closed string we have

$$M^2 = \frac{2}{\alpha'} \sum_{n=1}^{\infty} (\alpha_{-n} \alpha_n + \tilde{\alpha}_{-n} \tilde{\alpha}_n). \tag{2.1.24}$$

Bosonic strings provides a simple introduction to the subject of string theory, although it is not sufficient on its own from a phenomenological standpoint. We will come to see that the spectrum of the full quantised theory contains physical tachyons and there is a notable absence of spacetime fermions. However, we may fix both of these problems by introducing supersymmetry directly onto the worldsheet, leading us to the study of superstring theory.

2.1.2 Superstring theory

The approach of obtaining a theory of superstrings by introducing supersymmetry directly onto the worldsheet is known as the Ramond-Neveu-Schwarz (RNS) formalism. The bosonic fields $X^\mu(\tau, \sigma)$ are paired with fermionic partners $\psi^\mu(\tau, \sigma)$ which are spinors on the worldsheet with components ψ_-^μ and ψ_+^μ . The theory now has an $\mathcal{N} = 1$ superconformal algebra on the worldsheet where the supergravity multiplet contains the metric and a gravitino χ_a .

The analogue of the bosonic Polyakov action is given by

$$S_P = \frac{T}{2} \int d^2\sigma \sqrt{-g} \left[g^{ab} \partial_a X^\mu \partial_b X_\mu + \frac{i}{2} \psi^\mu \not{\partial} \psi_\mu + \frac{i}{2} (\chi_a \gamma^b \gamma^a \psi^\mu) \left(\partial_b X_\mu - \frac{i}{4} \chi_b \psi_\mu \right) \right], \quad (2.1.25)$$

where the two-dimensional gamma matrices are given by

$$\gamma^0 = \begin{pmatrix} 0 & -i \\ i & 0 \end{pmatrix}, \quad \gamma^1 = \begin{pmatrix} 0 & i \\ i & 0 \end{pmatrix}, \quad (2.1.26)$$

which satisfy the anticommutation relation

$$\{\gamma^a, \gamma^b\} = 2\eta^{ab}. \quad (2.1.27)$$

The Polyakov action is invariant under a local $\mathcal{N} = 1$ left-moving supersymmetry with the transformations given by

$$\begin{aligned} \delta X^\mu &= i\epsilon \psi^\mu, \\ \delta \psi^\mu &= \gamma^a \left(\partial_a X^\mu - \frac{i}{2} \chi_a \psi^\mu \right) \epsilon, \\ \delta \bar{\psi}^\mu &= 0, \\ \delta g_{ab} &= i\epsilon (\gamma_a \chi_b + \gamma_b \chi_a), \\ \delta \chi_a &= 2\nabla_a \epsilon, \end{aligned} \quad (2.1.28)$$

where ϵ is a left-moving Majorana-Weyl spinor. There is also a similar right-moving $\mathcal{N} = 1$ supersymmetry associated with the fermions $\bar{\psi}^\mu$. In a similar way to the case of the bosonic string, diffeomorphism and Weyl invariance can be used to work in the superconformal gauge, in which $g_{ab} = \eta_{ab}$ and $\chi_a = 0$. The

Polyakov action hence simplifies to

$$S_P = \frac{T}{2} \int d^2\sigma \left[\partial_a X^\mu \partial^a X_\mu + \frac{i}{2} \psi^\mu \not{\partial} \psi_\mu \right], \quad (2.1.29)$$

while the equations of motion can be written in the form

$$\partial_+ \psi_- = 0, \quad \partial_- \psi_+ = 0. \quad (2.1.30)$$

The non-zero components of the energy-momentum tensor are given by

$$\begin{aligned} T_{++} &= \partial_+ X^\mu \partial_+ X_\mu + \frac{i}{2} \psi_+^\mu \partial_+ \psi_{+\mu}, \\ T_{--} &= \partial_- X^\mu \partial_- X_\mu + \frac{i}{2} \psi_-^\mu \partial_- \psi_{-\mu}. \end{aligned} \quad (2.1.31)$$

There is also a conserved current associated with the worldsheet supersymmetry, known as the supercurrent. Its non-zero components are

$$J_+ = \psi_+^\mu \partial_+ X_\mu, \quad J_- = \psi_-^\mu \partial_- X_\mu. \quad (2.1.32)$$

The superconformal symmetry causes both the energy-momentum tensor and the supercurrent to vanish; conditions known as the super-Virasoro constraints.

For a closed string the fermionic fields can have either periodic or antiperiodic boundary conditions which correspond to two different sectors with separate mode expansions. Considering the right-movers only, we have the following sectors:

- Neveu-Schwarz (NS): Given by $\psi_-^\mu(\sigma + 2\pi) = -\psi_-^\mu(\sigma)$, with mode expansion

$$\psi_-(\tau, \sigma) = \sum_{r \in \mathbb{Z} + \frac{1}{2}} b_r^\mu e^{-2ir\sigma^-}. \quad (2.1.33)$$

- Ramond (R): Given by $\psi_-^\mu(\sigma + 2\pi) = \psi_-^\mu(\sigma)$, with mode expansion

$$\psi_-(\tau, \sigma) = \sum_{n \in \mathbb{Z}} d_n^\mu e^{-2in\sigma^-}. \quad (2.1.34)$$

So far we have only considered classical strings. In the following section we will quantise the theories and see how the full physical spectrum is constructed.

2.2 Quantisation

2.2.1 Canonical quantisation

The classical relativistic strings can be quantised in several ways, one of which, covariant canonical quantisation, shall be presented here while a brief mention of BRST quantisation will follow. We begin by taking the fields X^μ and their conjugate momenta $P^\mu = T\dot{X}^\mu$ and promoting them to operator valued fields obeying equal-time commutation relations

$$[X^\mu(\tau, \sigma), P_\nu(\tau, \sigma')] = i\delta(\sigma - \sigma')\delta_\nu^\mu, \quad (2.2.1)$$

$$[X^\mu(\tau, \sigma), X^\nu(\tau, \sigma')] = [P_\mu(\tau, \sigma), P_\nu(\tau, \sigma')] = 0, \quad (2.2.2)$$

while the worldsheet fermionic fields are similarly promoted to operators satisfying the anticommutation relations

$$\{\psi_a^\mu(\tau, \sigma), \psi_b^\nu(\tau, \sigma')\} = \pi\eta^{\mu\nu}\delta_{ab}\delta(\sigma - \sigma'). \quad (2.2.3)$$

Using the mode expansion for X^μ we obtain the commutation relations for the oscillators and centre of mass positions and momentum

$$[x^\mu, p_\nu] = i\delta_\nu^\mu, \quad (2.2.4)$$

$$[\alpha_n^\mu, \alpha_m^\nu] = [\tilde{\alpha}_n^\mu, \tilde{\alpha}_m^\nu] = n\delta_{n+m,0}\eta^{\mu\nu}, \quad (2.2.5)$$

while all other pairings commute. Similarly, the fermionic modes satisfy the anticommutation relations

$$\{d_m^\mu, d_n^\nu\} = \delta^{\mu\nu}\delta_{m+n,0}, \quad \{b_r^\mu, b_s^\nu\} = \delta^{\mu\nu}\delta_{m+n,0}. \quad (2.2.6)$$

Defining

$$a_n^\mu = \frac{\alpha_n^\mu}{\sqrt{n}}, \quad a_n^{\mu\dagger} = \frac{\alpha_{-n}^\mu}{\sqrt{n}}, \quad n > 0, \quad (2.2.7)$$

(and similarly for left-moving modes) gives a set of D creation and annihilation operators obeying $[a_n^\mu, a_m^{\nu\dagger}] = \eta^{\mu\nu}\delta_{mn}$. The negative frequency modes act as raising operators, while the positive frequency modes act as lowering operators of L_0 . The

ground state of the Hilbert space is defined as the state that is annihilated by all of the lowering operators. Therefore, the ground states in the R and NS sectors respectively are defined by

$$\begin{aligned}\alpha_n^\mu |0; k\rangle_{\text{R}} &= d_n^\mu |0; k\rangle_{\text{R}} = 0 \quad \forall n > 0, \\ \alpha_n^\mu |0; k\rangle_{\text{NS}} &= b_r^\mu |0; k\rangle_{\text{NS}} = 0 \quad \forall n, r > 0.\end{aligned}\tag{2.2.8}$$

We can then act on the ground states with the negative frequency modes to build the spectrum of states. In the R sector there exist anticommuting zero modes, $\{d_0^\mu, d_0^\nu\} = \eta^{\mu\nu}$. This leads to the fact that the vacuum state is a spinor in this sector, hence allowing for the presence of spacetime fermions in the physical spectrum.

We now introduce the generators of the super-Virasoro algebra, which are the modes of the energy-momentum tensor and the supercurrent. The modes of the supercurrent can be split into contributions coming from bosonic modes and those from fermionic modes, $L_m = L_m^B + L_m^F$, and for the closed string there are an equivalent set of modes given by \tilde{L}_m . We have

$$L_m^B = \frac{1}{2} \sum_{n \in \mathbb{Z}} : \alpha_{m-n}^\mu \alpha_{\mu n} :, \tag{2.2.9}$$

while the fermionic mode contributions and the modes of the supercurrent, G_r and F_n , are dependent on the sector. In the NS sector

$$\begin{aligned}L_m^F &= \frac{1}{2} \sum_{s \in \mathbb{Z} + 1/2} \left(\frac{m}{2} - s \right) : b_{m-s}^\mu b_{\mu s} :, \\ G_r &= \sum_{n \in \mathbb{Z}} \alpha_{\mu n} b_{r-n}^\mu, \quad r \in \mathbb{Z} + \frac{1}{2}.\end{aligned}\tag{2.2.10}$$

Similarly, in the R sector

$$\begin{aligned}L_m^F &= \frac{1}{2} \sum_{n \in \mathbb{Z}} \left(\frac{m}{2} - n \right) : d_{m-n}^\mu d_{\mu n} :, \\ F_m &= \sum_{n \in \mathbb{Z}} \alpha_{\mu n} b_{m-n}^\mu, \quad m \in \mathbb{Z}.\end{aligned}\tag{2.2.11}$$

Normal ordering in the above places all positive frequency modes to the right of

the negative frequency ones. These operators obey the super-Virasoro algebra

$$\begin{aligned} [L_m, L_n] &= (m - n)L_{m+n} + A_m \delta_{m+n,0}, \\ [L_m, G_r] &= \left(\frac{m}{2} - r\right) G_{m+r}, \\ \{G_r, G_s\} &= 2L_{r+s} + B_r \delta_{r+s}, \end{aligned} \tag{2.2.12}$$

where the anomaly terms A_m and B_r are dependent on the sector. In the NS sector we have

$$A_m = \frac{D}{8} m (m^2 - 1), \quad B_r = \frac{D}{8} \left(r^2 - \frac{1}{r}\right), \tag{2.2.13}$$

while in the R sector we replace G_r with F_m and

$$A_m = \frac{D}{8} m^3, \quad B_r = \frac{D}{8} r^2. \tag{2.2.14}$$

For the purely bosonic string we only have the L_m modes which obey the Virasoro algebra given by the first equation in Equation 2.2.12 where $A_m = \frac{D}{12} m(m^2 - 1)$. We find that the bosonic string is only Weyl invariant for spacetime dimension $D = 26$, while for superstrings we require $D = 10$ for Weyl anomaly cancellation.

2.2.2 BRST quantisation

We briefly mention some key aspects of BRST quantisation. This involves quantising the path integral and it exhibits Lorentz invariance manifestly. It is the analogue of the Fadeev-Popov procedure for gauge theories in QFT. It involves extending the Hilbert space through the introduction of a pair of fermionic ghost fields, b and c , and a pair of bosonic superghost fields, β and γ . The path integral is invariant up to a total derivative under a set of BRST transformations, which are generated by the BRST charge Q_B . For a consistent theory we require that the BRST charge is nilpotent, $Q_B^2 = 0$, while all physical states must be BRST invariant, satisfying $Q_B|\text{phys}\rangle = 0$.

2.2.3 The closed string spectrum

All of the physical states in a bosonic theory must obey the constraints

$$L_m|\text{phys}\rangle = 0 \quad \forall m > 0, \quad (L_0 - a)|\text{phys}\rangle = 0, \quad (2.2.15)$$

and similarly for the $\tilde{L}'s$. From this we obtain the mass-shell condition

$$\alpha' m_R^2 = N - a, \quad (2.2.16)$$

where N is the number operator, given by

$$N = \sum_{m>0} \alpha_{-m}^\mu \alpha_{\mu m}, \quad (2.2.17)$$

and similarly for m_R^2 and \tilde{N} . The physical state conditions imply level-matching, so we require $m_L^2 = m_R^2$. For the bosonic string we find the value $a = 1$, which results in the ground state having the mass-shell condition $\alpha' m^2 = -1$, and so it is tachyonic.

For closed superstrings, we have both a left and right moving super Virasoro algebra. We can build the spectrum of states by considering ground states corresponding to NS or R boundary conditions independently for each direction, and acting with raising operators. For now we will only describe the right movers, with the knowledge this should be paired with corresponding left movers. In the R sector we have the additional constraint $F_m|\text{phys}\rangle = 0 \quad \forall m > 0$ find $a = 0$, while in the NS sector we have the requirement $G_r|\text{phys}\rangle = 0 \quad \forall r > 0$ and $a = \frac{1}{2}$. The number operator now takes the form

$$N = \sum_{m>0} \alpha_{-m}^\mu \alpha_{\mu m} + \sum_{m>0} r \psi_{-m}^\mu \psi_{\mu m}, \quad (2.2.18)$$

where ψ_m^μ denotes the modes b_r^μ or d_m^μ depending on the sector.

The NS sector ground state $|0; k\rangle_{\text{NS}}$ has mass-shell condition

$$\alpha' m^2 = -\frac{1}{2}, \quad (2.2.19)$$

which is again tachyonic, while the first excited state $\psi_{-\frac{1}{2}}^\mu |0; k\rangle_{\text{NS}}$ is massless and

can be interpreted as a spacetime boson A^μ . All states in the NS sector are spacetime bosons.

Conversely, states in the R sector are spacetime fermions, where the R sector ground state $|0; k\rangle_R$ has mass-shell condition

$$\alpha' m^2 = 0. \quad (2.2.20)$$

2.2.4 The GSO projection

The spectrum of physical states for the superstring still seems to contain tachyonic states. However, these states are actually projected out of the spectrum through the Gliozzi-Scherk-Olive (GSO) projection. This procedure applies a projection operator to the physical states

$$|\text{phys}\rangle \rightarrow P_{\text{GSO}}|\text{phys}\rangle, \quad (2.2.21)$$

which arises due to the requirement of modular invariance. In the NS sector the projection operator is

$$P_{\text{GSO}} = \frac{1}{2} [1 - (-1)^{N_f}], \quad (2.2.22)$$

where the fermion number operator N_f is defined as $N_f = \sum_{r>0} b_{-r}^\mu b_{\mu r}$. Therefore in this sector all states should have an odd number of b oscillator excitations, while those with an even number are removed by the GSO projection. Clearly, this eliminates the tachyon that arises from this sector. It corresponds to the NS ground state $|0; k\rangle_{\text{NS}}$ which clearly has $N_f = 0$. Meanwhile, in the R sector their is a choice of projection operator is given by

$$P_{\text{GSO}}^\pm = \frac{1}{2} [1 \mp \Gamma^{11}(-1)^{N_f}], \quad (2.2.23)$$

where now $N_f = \sum_{n>0} d_{-n}^\mu d_{\mu n}$ Γ^{11} is the 10d analogue of the Dirac matrix γ_5 in 4d. For type II superstrings the GSO projection is applied separately to the left and right moving directions. For the R-R sector we can choose the projection operator for the two directions to be the same or different, corresponding to the type IIA or type IIB superstrings.

2.2.5 The heterotic string

For closed strings, the left and right-moving sectors are independent. Therefore, we can set the right-moving side to be that of a superstring with an $N = 1$ superconformal algebra, while the left-moving side is purely bosonic with a Virasoro algebra. Anomaly-free theories of this kind are 10-dimensional, where the extra degrees of freedom on the bosonic side are compactified on a 16-dimensional lattice Λ . In the following section, we will come to see that consistent strings theories are required to be modular invariant, which in this context imposes the constraint that the lattice must be even self-dual. Therefore, lattice vectors $\mathbf{P} \in \Lambda$ must satisfy $\mathbf{P}^2 \in 2\mathbb{Z}$ and $\Lambda^* = \Lambda$. There are two inequivalent sixteen-dimensional lattices that satisfy this requirement, the $E_8 \times E_8$ lattice and the $O(32)/\mathbb{Z}_2$ lattice. Focusing on the $E_8 \times E_8$ lattice, it is spanned by vectors of the form

$$(n_1 + \frac{a}{2}, \dots, n_8 + \frac{a}{2}; n'_1 + \frac{b}{2}, \dots, n'_8 + \frac{b}{2}), \quad (2.2.24)$$

where $n_I, n'_I \in \mathbb{Z}$, $\sum_I n_I, \sum_I n'_I \in 2\mathbb{Z}$, and $a, b \in \{0, 1\}$. The theory has $\mathcal{N} = 1$ supersymmetry in $10d$, it is chiral and contains a massless supergravity multiplet, and a massless vector supermultiplet in the adjoint of $E_8 \times E_8$. In the NS sector the massless states are $\psi_{-1/2}^i \tilde{\alpha}_{-1}^j |0; k\rangle_{\text{NS}}$, giving the graviton, antisymmetric tensor and dilaton, and $\psi_{-1/2}^i \tilde{J}_{-1}^a |0; k\rangle_{\text{NS}}$, giving vectors in the adjoint of the gauge group $E_8 \times E_8$. In the R sector, the massless states are $\tilde{\alpha}_{-1}^j |0; k\rangle_{\text{R}}$ giving a gravitino and a dilatino, and $\tilde{J}_{-1}^a |0; k\rangle_{\text{R}}$ giving Majorana-Weyl fermions in the adjoint of $E_8 \times E_8$.

2.3 The one-loop partition function and modular invariance

2.3.1 The torus

A key condition that string theory must satisfy to be consistent is the property of modular invariance. We can describe its impact by looking at the one-loop partition function, or equivalently to the one-loop vacuum to vacuum amplitude. We will describe the perturbative series expansion in string theory in more detail in a later section, but for now we only need to know that at this order for closed strings, the amplitude has the topology of a torus.

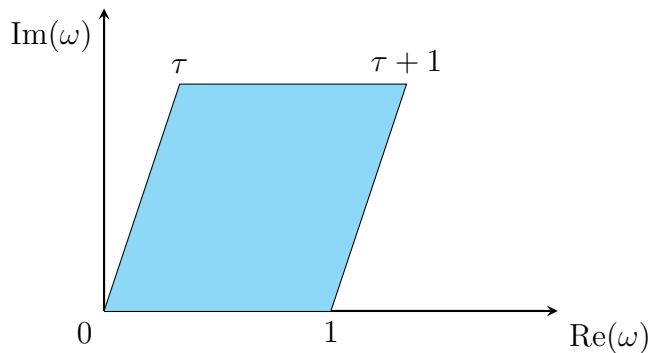

Figure 2.2: Torus as a quotient of the complex plane.

We can parametrise the points on the torus by the complex quantity $\omega = \sigma_1 + \tau\sigma_2$, where $\tau = \tau_1 + i\tau_2$ is the complex modular parameter labelling conformally inequivalent tori. The associated metric is a symmetric and positive-definite matrix given by

$$g_{ij} = \frac{1}{\tau_2} \begin{pmatrix} 1 & \tau_1 \\ \tau_1 & |\tau|^2 \end{pmatrix}. \quad (2.3.1)$$

The space of conformally inequivalent tori parametrised by τ is called the moduli space \mathcal{M} . We can consider two transformations acting on τ , called the T and S transformations, which leave the torus unchanged

- $T : \tau \rightarrow \tau + 1$
- $S : \tau \rightarrow -\frac{1}{\tau}$

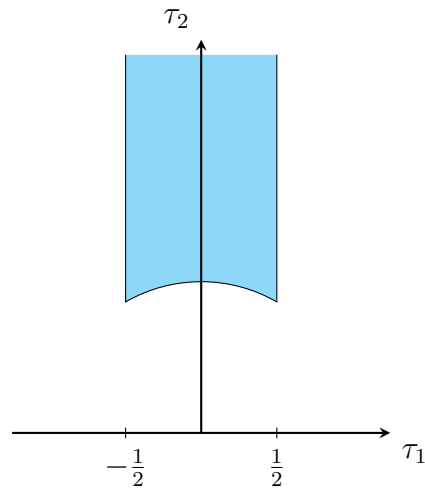

Figure 2.3: Fundamental domain.

A general modular transformation can then be constructed from combinations of S and T transformations, taking the form

$$\tau \rightarrow \frac{a\tau + b}{c\tau + d}, \quad \text{with } ad - bc = 1, \quad (2.3.2)$$

where $a, b, c, d \in \mathbb{Z}$. This forms the group $SL(2, \mathbb{Z})$.

The group of modular transformations maps the upper half plane to a region known as the fundamental domain which contains all points which cannot be mapped to any other through any modular transformation. The fundamental domain \mathcal{F} of the group $SL(2, \mathbb{Z})$ is defined as

$$\mathcal{F} = \left\{ \tau \in \mathbb{H} \mid |\tau_1| \leq \frac{1}{2}, |\tau| \geq 1 \right\}, \quad (2.3.3)$$

as depicted in Figure 2.3. After gauge fixing diffeomorphism and Weyl invariance, computation of the amplitude involves the integration of the parameter τ over the fundamental domain, with the $SL(2, \mathbb{Z})$ invariant measure given by

$$\int \frac{d^2\tau}{\tau_2^2}. \quad (2.3.4)$$

2.3.2 The one-loop partition function

We consider here the one-loop vacuum to vacuum amplitude in more detail for certain models. The torus path integral in the Hamiltonian representation takes the form

$$Z(\tau, \bar{\tau}) = \text{Tr} \left[q^{L_0 - \frac{c}{24}} \bar{q}^{\bar{L}_0 - \frac{\bar{c}}{24}} \right], \quad (2.3.5)$$

where $q \equiv e^{2\pi i\tau}$, and c, \bar{c} are the right and left moving central charges of the CFT. This is the spectrum-generating partition function, where the trace is over all the states that propagate around the loop.

The partition function involves an integral over the fundamental domain and can be written in the form¹

$$Z = \int_{\mathcal{F}} \frac{d^2\tau}{\tau_2} \mathcal{Z}(\tau), \quad (2.3.6)$$

where the integrand \mathcal{Z} is a $SL(2, \mathbb{Z})$ modular invariant quantity.

The contribution to the partition function from a free scalar field is given by

$$\mathcal{Z}_{\text{scalar}} \sim \frac{1}{\sqrt{\tau_2 \eta \bar{\eta}}}, \quad (2.3.7)$$

while for a single complex fermion, the contribution is dependent on the spin structure and is given by

$$\mathcal{Z}_{\psi} \begin{bmatrix} a \\ b \end{bmatrix} = \frac{\vartheta \begin{bmatrix} a \\ b \end{bmatrix}}{\eta}, \quad (2.3.8)$$

for $a, b \in \mathbb{R}$. In the above, $\eta(\tau)$ is Dedekind eta function and $\vartheta \begin{bmatrix} a \\ b \end{bmatrix}$ are the Jacobi theta functions as given in Appendix A. The full partition function includes a sum over spin structures. Finally, ghosts contribute a factor of $(\eta \bar{\eta})^2$, while the superghost insertions cancel the contributions from the longitudinal worldsheet fermions $\psi^{0,1}$. The full partition function for the bosonic string in 26 dimensions is given by

$$Z \sim \int_{\mathcal{F}} \frac{d^2\tau}{\tau_2^2} \frac{1}{(\sqrt{\tau_2 \eta \bar{\eta}})^{24}}. \quad (2.3.9)$$

¹Note that the integrand itself is sometimes referred to as the partition function. We will refer to both in this way where the distinction should be clear through the context.

For the heterotic string the contribution from the 16 left-moving compact bosons ϕ^I is

$$\mathcal{Z}_{\text{compact}}(\bar{q}) = \sum_{\vec{p}_R} \frac{\bar{q}^{\vec{p}_R^2}}{\bar{\eta}^{16}} = \frac{\bar{\Gamma}_{16}(\bar{q})}{\bar{\eta}^{16}}, \quad (2.3.10)$$

where \vec{p}_R is a lattice vector, and so the full partition function for the heterotic string is of the form

$$Z \sim \int_{\mathcal{F}} \frac{d^2\tau}{\tau_2^2} \frac{\bar{\Gamma}_{16}(\bar{q})}{\tau_2^4 \eta^{12} \bar{\eta}^{24}} \sum_{a,b=0}^1 e^{\pi i(a+b+ab)} \vartheta^4 \left[\begin{matrix} a/2 \\ b/2 \end{matrix} \right]. \quad (2.3.11)$$

For superstring models with unbroken spacetime supersymmetry, the partition function vanishes due to a cancellation between spacetime bosons and fermion. This can be seen explicitly for the one-loop partition function of the heterotic string in the sum over spin structures which vanishes through the abstruse identity

$$\sum_{a,b=0}^1 e^{\pi i(a+b+ab)} \vartheta^4 \left[\begin{matrix} a/2 \\ b/2 \end{matrix} \right] = 0. \quad (2.3.12)$$

In general, the integrand of the one-loop partition function can be expressed as an expansion into Fourier modes

$$\mathcal{Z} = \sum_{m,n} a_{mn} q^m \bar{q}^n, \quad (2.3.13)$$

where the exponent gives the mass level, and the coefficient a_{mn} gives the difference in the number of bosons and fermions at each mass level. Naturally, all of the Fourier coefficients will be identically zero in any supersymmetric theory.

2.4 Compactification

2.4.1 Toroidal compactification

Superstring theories in their most basic constructions are ten-dimensional. Therefore, we require some process that ultimately results in a four-dimensional space-time to begin to construct phenomenologically viable models. One method of reducing the dimension of the $10D$ string theories is through compactification, with the simplest type achieved by taking the internal compact space to be a d -dimensional torus \mathbb{T}_d . If we specify to the case of compactifying two dimensions on a \mathbb{T}_2 torus, the worldsheet dynamics can then be described by two free compact scalars, where the periodicity of each around the two cycles of the torus are

$$\begin{aligned} X^I(\sigma_1 + 2\pi, \sigma_2) &= X^I(\sigma_1, \sigma_2) + 2\pi n^I R_I, \\ X^I(\sigma_1, \sigma_2 + 2\pi) &= X^I(\sigma_1, \sigma_2) + 2\pi m^I R_I. \end{aligned} \tag{2.4.1}$$

In the above $n^I, m^I \in \mathbb{Z}$ are referred to as winding and momentum numbers respectively and R_I are the compact radii. The solutions to the classical equations of motion are given by

$$X_{\text{class}}^I(\sigma_1, \sigma_2) = R_I(n^I \sigma_1 + m^I \sigma_2), \tag{2.4.2}$$

and the path integral can now be written as an integral over quantum fluctuations and an instanton sum over the exponential of the classical action.

The metric G_{ij} and antisymmetric tensor field B_{ij} associated with the compact torus are given by

$$G_{ij} = \frac{T_2}{U_2} \begin{pmatrix} 1 & U_1 \\ U_1 & |U|^2 \end{pmatrix}, \quad B_{ij} = \begin{pmatrix} 0 & T_1 \\ -T_1 & 0 \end{pmatrix}, \tag{2.4.3}$$

where $T = T_1 + iT_2$ and $U = U_1 + iU_2$ are the Kähler and complex structure moduli respectively. The imaginary parts of these moduli are related to the two compact radii by $T_2 = R_1 R_2$ and $U_2 = R_2/R_1$. The partition function on the

torus in the Hamiltonian form is given by

$$Z_{2,2}(G, B) = \frac{1}{|\eta(\tau)|^4} \sum_{\mathbf{n}, \mathbf{m}} q^{P_L^2/2} \bar{q}^{P_R^2/2}, \quad (2.4.4)$$

where

$$P_{L,R}^2 = P_{L,R}^i G_{ij} P_{L,R}^j, \quad (2.4.5)$$

$$P_L^i = \frac{G^{ij}}{\sqrt{2}} \left[m_j + (B_{jk} + G_{jk}) n^k \right], \quad (2.4.6)$$

$$P_R^i = \frac{G^{ij}}{\sqrt{2}} \left[m_j + (B_{jk} - G_{jk}) n^k \right]. \quad (2.4.7)$$

One may also write the partition function in the Lagrangian form by performing a Poisson resummation on the integers m_i . The partition function then takes the form

$$Z_{2,2}(G, B) = \frac{\Gamma_{2,2}(G, B)}{|\eta(\tau)|^4}, \quad (2.4.8)$$

where the Narain lattice $\Gamma_{d,d}(G, B)$ is given by

$$\Gamma_{2,2}(G, B) = \frac{\det G}{\sqrt{\tau_2}} \sum_{\mathbf{n}, \mathbf{m}} e^{-\frac{\pi}{\tau_2} (G_{ij} + B_{ij})(m_i + n_i \tau)(m_j + n_j \bar{\tau})}. \quad (2.4.9)$$

The partition function contains a symmetry known as T-duality, which for a d -dimensional torus is given by the symmetry group $O(d, d+16; \mathbb{Z})$. For the case of the \mathbb{T}_2 torus, this splits into two independent $PSL(2, \mathbb{Z})$ symmetries for the moduli T and U , along with a symmetry under $T \leftrightarrow U$.

2.4.2 The \mathbb{Z}_2 orbifold

While toroidal compactifications offer the simplest method of achieving consistent string theories in four spacetime dimensions, the number of unbroken supersymmetries in the resulting theories is too high from a phenomenological point of view. However, it is possible to reduce the number of supersymmetries by compactification on an orbifold. These surfaces arise when we take the quotient M/G of a manifold M by a discrete symmetry group G . The resultant surfaces are singular, being flat almost everywhere except at certain fixed points which are left invariant under the symmetry group G . The particular orbifold of interest for

our purposes is obtained by taking the quotient of the \mathbb{T}_2 torus by the discrete group \mathbb{Z}_2 as depicted in Figure 2.4.

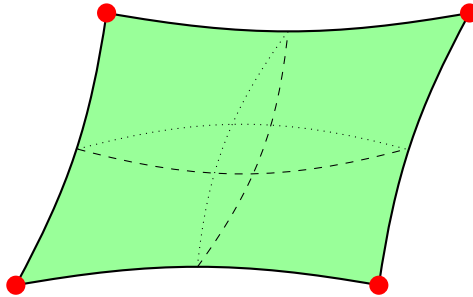

Figure 2.4: The $\mathbb{T}_2/\mathbb{Z}_2$ orbifold. The red dots indicate the 4 fixed points.

For closed strings the periodicity condition generalises to

$$X^\mu(\sigma_1, \sigma_2 + 2\pi) = gX^\mu(\sigma_1, \sigma_2), \quad (2.4.10)$$

for some $g \in G$. There are two types of physical states that occur in the spectrum of strings on an orbifold background geometry. The first are called untwisted states, which are those that are invariant under the symmetry group G and so correspond to $g = 1$. Note that some of the states from the original theory are projected out of the spectrum. It is from this fact that the number of supersymmetries can be reduced.

The second type of physical string states are called twisted states, and are new closed string states that appear after orbifolding. The twisted states are localised at orbifold singularities, living on the boundary of the compact space while the untwisted states live in the bulk. Therefore, it is only the untwisted states which can have any dependence on the radii corresponding to the compact dimensions. This result proves to be important when supersymmetry breaking by coordinate dependent compactification is considered since the supersymmetry breaking becomes manifest through certain states receiving shifts in their mass proportional to the compact radii. In this mechanism the twisted states are guaranteed to remain supersymmetric.

The twisted sectors must necessarily be included for modular invariance, and

the partition function is obtained by summing over all sectors

$$\sum_{h,g=0,\frac{1}{2}} \mathcal{Z} \begin{bmatrix} h \\ g \end{bmatrix}. \quad (2.4.11)$$

The contribution from a twisted compact boson is given by

$$\mathcal{Z} \begin{bmatrix} h \\ g \end{bmatrix} = 2 \left| \frac{\eta}{\vartheta \begin{bmatrix} 1/2 - h \\ 1/2 - g \end{bmatrix}} \right|, \quad (2.4.12)$$

with $(h, g) \neq (0, 0)$, while a twisted fermion gives the contribution

$$\mathcal{Z}_F = \frac{\vartheta \begin{bmatrix} a + h \\ b + g \end{bmatrix}}{\eta}. \quad (2.4.13)$$

2.4.3 Wilson lines

Compactification allows for the presence of non-vanishing Wilson lines

$$U_I = e^{i \int_0^{2\pi R_I} dx^I A_I}, \quad (2.4.14)$$

where I runs over the compact dimensions. The Wilson lines A^I are massless scalars with zero field strength. They are moduli and their presence can break the gauge symmetry and modify the physical spectrum of the lower dimensional theory. Therefore, this mechanism can prove useful for the purposes of constructing phenomenologically appealing models. The inclusion of non-vanishing Wilson lines has the effect of altering the Narain lattice $\Gamma_{d,d}$ and results in a redefinition of both the Kähler and complex structure moduli.

2.5 Free fermionic models

2.5.1 Bosonisation

There is a physical equivalence between 2d quantum field theories with bosonic degrees of freedom and fermionic degrees of freedom due to the absence of a proper concept of spin in 2d. The relationship allows for the construction of free-fermionic models, and may be derived from the operator product expansions (OPE) of bosons and fermions. The OPE for bosonic fields $X(z)$ is given by

$$X(z)X(0) = -\ln|z|^2 + \mathcal{O}(z), \quad (2.5.1)$$

and so if we instead consider the operators $e^{\pm X(z)}$, we have

$$\begin{aligned} e^{iX(z)}e^{-iX(0)} &= \frac{1}{z} + \mathcal{O}(z), \\ e^{iX(z)}e^{iX(0)} &= \mathcal{O}(z), \\ e^{-iX(z)}e^{-iX(0)} &= \mathcal{O}(z). \end{aligned} \quad (2.5.2)$$

Similarly, we may now consider the operator product expansion between two complex Majorana-Weyl fermions

$$\psi = \frac{1}{\sqrt{2}}(\psi^1 + i\psi^2), \quad \bar{\psi} = \frac{1}{\sqrt{2}}(\psi^1 - i\psi^2), \quad (2.5.3)$$

where $\psi^{1,2}$ are real fermions. Their OPE's are

$$\begin{aligned} \psi(z)\bar{\psi}(0) &= \frac{1}{z} + \mathcal{O}(z), \\ \psi(z)\psi(0) &= \mathcal{O}(z), \\ \bar{\psi}(z)\bar{\psi}(0) &= \mathcal{O}(z). \end{aligned} \quad (2.5.4)$$

We can see that Equation 2.5.2 and Equation 2.5.4 are equivalent and so we find the correspondence

$$\psi(z) \sim e^{iX(z)}, \quad \bar{\psi}(z) \sim e^{-iX(z)}. \quad (2.5.5)$$

We can demonstrate the equivalence of a complex fermion and a compact boson with radius $R = 1/\sqrt{2}$ by consideration of the one-loop partition function.

Beginning with the partition function for the fermion and Poisson resumming over the theta functions we find

$$\begin{aligned}
Z &= \frac{1}{2} \sum_{a,b=\{0,\frac{1}{2}\}} \left| \frac{\vartheta \begin{bmatrix} a \\ b \end{bmatrix}}{\eta} \right|^2 \\
&= \frac{1}{2|\eta|^2 \sqrt{2\tau_2}} \sum_{a,b=\{0,\frac{1}{2}\}} \sum_{n,m \in \mathbb{Z}} e^{-\frac{\pi}{2\tau_2}|n+\tau m|^2 + \pi i(m+2a)(n+2b)} \\
&= \frac{1}{\sqrt{\tau_2}} \sum_{m,n \in \mathbb{Z}} \exp \left[-\frac{\pi}{2\tau_2}|n + \tau m|^2 \right],
\end{aligned} \tag{2.5.6}$$

which is the partition function for a compact boson at radius $R = 1/\sqrt{2}$.

2.5.2 The construction of free fermionic models

Free fermionic models are constructed by fermionising all internal worldsheet degrees of freedom at special points in moduli space as specified in the previous subsection. They allow for the direct construction of string models with space-time dimension less than ten. For a single complex left-moving fermionic degree of freedom $\Psi(\sigma_1, \sigma_2)$, the boundary conditions on the torus in the σ_1 and σ_2 directions can be specified by

$$\begin{aligned}
\Psi(\sigma_1, \sigma_2 + 2\pi) &= e^{-2\pi i u} \Psi(\sigma_1, \sigma_2), \\
\Psi(\sigma_1 + 2\pi, \sigma_2) &= e^{-2\pi i v} \Psi(\sigma_1, \sigma_2),
\end{aligned} \tag{2.5.7}$$

where $0 \leq u, v \leq 1$. The associated contribution to the partition function takes the form

$$Z_u^v = \text{Tr} \left(q^{\hat{H}_v} e^{2\pi i(1/2-u)\hat{N}_v} \right), \tag{2.5.8}$$

where \hat{H}_v and \hat{N}_v are the Hamiltonian and fermionic number operator respectively for complex fermionic left-movers with boundary conditions twisted by $e^{2\pi i v}$.

In the free fermionic formulation a model is described in terms of a set of basis vectors \mathbf{V}_i which give the boundary conditions of all the fermions on the worldsheet. Denoting both left and right-moving fermionic degrees of freedom by

$\Psi^l(\sigma_1, \sigma_2)$, the boundary conditions can be written in the form

$$\Psi^l(\sigma_1, \sigma_2 + 2\pi) = e^{-2\pi i V^l} \Psi^l(\sigma_1, \sigma_2), \quad (2.5.9)$$

where $0 \leq V^l < 1$. A vector \mathbf{V} of boundary conditions V^l can be split into right and left-moving vectors \mathbf{V}_R and \mathbf{V}_L so that

$$\mathbf{V} = (\mathbf{V}_R \mid \mathbf{V}_L). \quad (2.5.10)$$

The overall contribution to the one-loop partition function from the fermion fields is a sum over all possible boundary conditions, each with an associated GSO coefficient

$$\mathcal{Z}_f = \sum_{\{\alpha, \beta\}} C_\beta^\alpha Z_{\beta \mathbf{V}}^{\alpha \overline{\mathbf{V}}}, \quad (2.5.11)$$

where we can write

$$Z_{\beta \mathbf{V}}^{\alpha \overline{\mathbf{V}}} = e^{2\pi i \beta \mathbf{V} \cdot \alpha \overline{\mathbf{V}}} \frac{1}{\eta^8 \overline{\eta}^{24}} \prod_{i_R} \vartheta \left[\begin{smallmatrix} \alpha \mathbf{v}_i \\ -\beta \mathbf{v}_i \end{smallmatrix} \right] \prod_{i_L} \overline{\vartheta} \left[\begin{smallmatrix} \alpha \mathbf{v}_i \\ -\beta \mathbf{v}_i \end{smallmatrix} \right], \quad (2.5.12)$$

and the GSO coefficients are given by

$$C_\beta^\alpha = \exp \left[2\pi i (\alpha s + \beta s + \beta_i k_{ij} \alpha_j - \beta \mathbf{V} \cdot \alpha \overline{\mathbf{V}}) \right], \quad (2.5.13)$$

where k_{ij} are the structure constants. The notation is $\overline{\alpha \mathbf{V}} \equiv \overline{\sum_i \alpha_i V_i}$, where the α_i are integers with values from 0 to $m_i - 1$, where m_i is the lowest common denominator of all the components in V_i . We also have $s_i \equiv V_i^1$, which gives the spin-statistics of the vector V_i .

The worldsheet supercurrent is defined as

$$T_F(z) = \psi^\mu(z) \partial_z X_\mu(z) + \sum_I \chi^I y^I w^I, \quad (2.5.14)$$

where χ^I is a compact fermion and y^I and w^I come from the fermionisation of a compact boson. In order for this supercurrent to be well defined, each of the terms must have the same boundary conditions. Therefore, we have a constraint on the boundary conditions (a^I, b^I, c^I) for the triplet (χ^I, y^I, w^I) given by

$$a^I + b^I + c^I = s \pmod{1}. \quad (2.5.15)$$

For a string model to be consistent it must satisfy constraints which guarantee modular invariance, correct spacetime spin statistics and invariance of the worldsheet supercurrent. These constraints (known as the KLST rules) are guaranteed to hold if

$$\begin{aligned} m_j k_{ij} &= 0 \quad \text{mod } (1), \\ k_{ij} + k_{ji} &= V_i \cdot V_j \quad \text{mod } (1), \\ k_{ii} + k_{i0} + s_i &= \frac{1}{2} V_i \cdot V_i \quad \text{mod } (1), \end{aligned} \tag{2.5.16}$$

where the basis vectors and choice of structure constants k_{ij} specify the theory completely.

The mass formula for states in the spectrum is given by

$$\begin{aligned} M_{L,R}^2 &= \sum_{\ell:\text{left,right}} \left\{ E_{\alpha V^\ell} + \sum_{q=1}^{\infty} \left[(q - \overline{\alpha V^\ell}) \bar{n}_q^\ell + (q + \overline{\alpha V^\ell} - 1) n_q^\ell \right] \right\} \\ &\quad - \frac{(D-2)}{24} + \sum_{i=1}^D \sum_{q=1}^{\infty} q M_q^i, \end{aligned} \tag{2.5.17}$$

where the sum over ℓ is over left or right-moving worldsheet fermions, n_q and \bar{n}_q are occupation numbers for complex fermions and M_q are occupation numbers for complex bosons. D is the number of uncompactified spacetime dimensions and $E_{\alpha V^\ell}$ is the vacuum energy from the fermions, given by

$$E_{\alpha V^\ell} = \frac{1}{2} \left[(\overline{\alpha V^\ell})^2 - \frac{1}{12} \right]. \tag{2.5.18}$$

As usual, the level-matching constraint, $M_L^2 = M_R^2$, must be satisfied for physical states.

2.5.3 Coordinate dependent compactification

Scherk-Schwarz in field theory

There has been recent interest in superstring theories which have broken spacetime supersymmetry by construction. We focus on models that make use of a technique of supersymmetry breaking arising from the compactification of extra

dimensions, known as Scherk-Schwarz supersymmetry breaking. We begin here with a description as it arose in field theory before giving its generalisation to the context of string theory.

We begin by taking a theory of a scalar field ϕ in a $(4 + 1)$ -dimensional spacetime $\mathcal{M}^{1,3} \times S^1$, and impose the periodic boundary conditions

$$\phi(x^\mu, x^5 + 2\pi R) = \phi(x^\mu, x^5), \quad (2.5.19)$$

where $\mu = 1, \dots, 4$. We can then Fourier expand in the compact coordinate to give

$$\phi(x^\mu, x^5) = \sum_{n \in \mathbb{Z}} e^{\frac{inx^5}{R}} \phi_n(x^\mu), \quad (2.5.20)$$

giving the well known Kaluza-Klein tower of states with mass $m^2 = \frac{n^2}{R^2}$. Instead, consider what happens when the theory is invariant with respect to a symmetry operator $O = \exp(iQ\theta)$. The periodicity conditions are now given by

$$\phi(x^\mu, x^5 + 2\pi R) = e^{iQ\theta} \phi(x^\mu, x^5). \quad (2.5.21)$$

After making the field redefinition

$$\phi(x^\mu, x^5) = e^{\frac{iQ\theta x^5}{2\pi R}} \hat{\phi}(x^\mu, x^5), \quad (2.5.22)$$

the field $\hat{\phi}(x^\mu, x^5)$ can be Fourier expanded in the compact coordinate as before, resulting in a tower of states with mass

$$m^2 = \left(\frac{2\pi n + q\theta}{2\pi R} \right)^2, \quad (2.5.23)$$

where q is the charge of the state acted upon by the symmetry generator Q . The result of the Scherk-Schwarz mechanism is that the Kaluza-Klein masses are shifted by value proportional to the charge of the state.

The string theory realisation

The stringy generalisation of the Scherk-Schwarz SUSY breaking mechanism is known as coordinate dependent compactification (CDC). This process lifts the

mass of some states and splits the spectrum at scale of order $1/R$, where R is a generic radius of the compact dimensions. We proceed by deforming a model through the introduction of a local generator Q of the $U(1)$ worldsheet symmetry, noting that the worldsheet supercurrent must be invariant under the discrete symmetry in order for the SUSY breaking to be spontaneous.

We can consider the effect of compactifying two dimensions on a $\mathbb{T}_2/\mathbb{Z}_2$ orbifold using CDC. This introduces a vector \mathbf{e} of shifts in the charge lattice that will modify the Virasoro generators in a way that is dependent on the two radii $R_{i=1,2}$ of the \mathbb{T}_2 torus. The modified Virasoro generators are given by

$$\begin{aligned} L'_0 &= \frac{1}{2} [\mathbf{Q}_L - \mathbf{e}_L(n_1 + n_2)]^2 + \frac{1}{4} \left[\frac{m_1 + m_{\mathbf{e}}}{r_1} + n_1 r_1 \right]^2 \\ &\quad + \frac{1}{4} \left[\frac{m_2 + m_{\mathbf{e}}}{r_2} + n_2 r_2 \right]^2 - 1 + \text{additional oscillator contributions}, \\ \bar{L}'_0 &= \frac{1}{2} [\mathbf{Q}_R - \mathbf{e}_R(n_1 + n_2)]^2 + \frac{1}{4} \left[\frac{m_1 + m_{\mathbf{e}}}{r_1} - n_1 r_1 \right]^2 \\ &\quad + \frac{1}{4} \left[\frac{m_2 + m_{\mathbf{e}}}{r_2} - n_2 r_2 \right]^2 - \frac{1}{2} + \text{additional oscillator contributions}, \end{aligned} \tag{2.5.24}$$

where $R_i = r_i/\sqrt{\alpha'}$ and all dot products are Lorentzian and

$$m_{\mathbf{e}} = \mathbf{e} \cdot \mathbf{Q} - \frac{1}{2}(n_1 + n_2)\mathbf{e} \cdot \mathbf{e}. \tag{2.5.25}$$

Therefore, we have

$$\begin{aligned} L'_0 + \bar{L}'_0 &= L_0 + \bar{L}_0 - (n_1 + n_2)(\mathbf{e}_L \cdot \mathbf{Q}_L + \mathbf{e}_R \cdot \mathbf{Q}_R) + \frac{1}{2}(n_1 + n_2)^2(\mathbf{e}_L^2 + \mathbf{e}_R^2) \\ &\quad + \frac{1}{2} \left(\frac{1}{r_1^2} + \frac{1}{r_2^2} \right) m_{\mathbf{e}}^2 + \left(\frac{m_1}{r_1^2} + \frac{m_2}{r_2^2} \right) m_{\mathbf{e}}, \\ L'_0 - \bar{L}'_0 &= L_0 - \bar{L}_0. \end{aligned} \tag{2.5.26}$$

The level-matching condition (and fermionic number projections) is unaffected by the presence of the CDC. The physical states present in the original theory are unchanged apart from their masses, and so the symmetry breaking is spontaneous. However, only the states living in the untwisted sector can be affected by the

breaking of supersymmetry. States in the twisted sectors live at the fixed points of the orbifold and so do not feel the effects of the extra dimensions. Therefore, the entire spectrum in the twisted sectors remains supersymmetric.

The cosmological constant

The value of the cosmological constant Λ in superstring theories broken by CDC is generically non-zero, putting it at odds with phenomenological observations which place it at the order $\Lambda \sim 10^{-122}$. Nevertheless, there are classes of non-SUSY string models which have an exponentially suppressed value of the cosmological constant at least up to one-loop order. One such class of models [7] can be constructed by starting with a $6D$ theory in the free-fermionic formulation, where models are defined by a set of 28-dimensional basis vectors \mathbf{V}_i and structure constants k_{ij} which obey the KLST rules. Compactifying the model down to $4D$ on a $\mathbb{T}_2/\mathbb{Z}_2$ orbifold would give a $\mathcal{N} = 1$ theory, while if we simultaneously utilise coordinate dependent compactification, supersymmetry is instead spontaneously broken to $\mathcal{N} = 0$.

The twisted sectors remain supersymmetric and so their contribution the cosmological constant vanishes. An analysis of untwisted sector determines that contributions from non-level matched and massive states are exponentially suppressed while the dominant and potentially large contributions come solely from the massless states, which are found to be proportional to $N_b - N_f$, the number of massless bosons minus fermions. Clearly, before supersymmetry is broken fully, the spectrum is guaranteed to contain an equal number of bosons and fermions within each mass level. After supersymmetry is broken, however, this degeneracy between bosons and fermions no longer holds generally. Nevertheless, it is possible to have an equal number of massless bosons and fermions through a suitable choice of basis vectors and structure constants. The one-loop cosmological constant in the untwisted sector for these models can be written as

$$\Lambda_{1\text{-loop}}^{(D)} = -\frac{1}{2}\mathcal{M}^{(D)} \int_{\mathcal{F}} \frac{d^2\tau}{\tau_2^2} \mathcal{Z}_{1\text{-loop}}(\tau), \quad (2.5.27)$$

where the partition function is given by

$$\mathcal{Z}_{1\text{-loop}}(\tau) = \frac{1}{\tau_2 \eta^8 \bar{\eta}^{22}} \sum_{\vec{l}, \vec{n}} \mathcal{Z}_{\vec{l}, \vec{n}} \sum_{\alpha, \beta} \tilde{C}_\beta^\alpha \prod_{i_R} \vartheta \left[\begin{smallmatrix} \alpha \mathbf{V}_i - n \mathbf{e}_i \\ \beta \mathbf{V}_i + l \mathbf{e}_i \end{smallmatrix} \right] \prod_{j_L} \bar{\vartheta} \left[\begin{smallmatrix} \alpha \mathbf{V}_j - n \mathbf{e}_j \\ \beta \mathbf{V}_j + l \mathbf{e}_j \end{smallmatrix} \right], \quad (2.5.28)$$

and the Narain lattice factor is

$$\mathcal{Z}_{\vec{l}, \vec{n}} = \frac{r_1 r_2}{\tau_2 \eta^2 \bar{\eta}^2} \sum_{\vec{l}, \vec{n}} \exp \left\{ -\frac{\pi}{\tau_2} \left[r_1^2 |l_1 - n_1 \tau|^2 + r_2^2 |l_2 - n_2 \tau|^2 \right] \right\}. \quad (2.5.29)$$

The generalised GSO coefficients are given by

$$\tilde{C}_\beta^\alpha = \exp \left\{ -2\pi i \left[n \mathbf{e} \cdot \beta \mathbf{V} - \frac{1}{2} n l e^2 \right] \right\} C_\beta^\alpha, \quad (2.5.30)$$

and where the coefficients C_β^α are those of the original theory before CDC is implemented²,

$$C_\beta^\alpha = \exp [2\pi i (\alpha s + \beta s + \beta_i k_{ij} \alpha_j)]. \quad (2.5.31)$$

²Note that here the factor of $e^{2\pi i \beta V \cdot \bar{\alpha} V}$ from the partition function has been absorbed into the definition of C_β^α

2.6 String perturbation theory

2.6.1 The genus expansion

One can consider a perturbative series expansion for string scattering amplitudes, where the series is taken as a loop expansion in the genus g . To obtain the S-matrix, the incoming and outgoing states are taken to infinity, and subsequently Weyl invariance is used to map the external states to local disturbances on the worldsheet. The state-operator map can then be utilised to place vertex operators at these points. This method restricts the amplitudes to those which are on-shell only. One then proceeds to sum over all physically distinct cases, while accounting for $\text{diff} \times \text{Weyl}$ gauge invariance. This is the Polyakov approach to string perturbation theory, for which the overall n -particle amplitude is given by

$$\mathcal{A}_n(k_i, \epsilon_i) = \sum_{\text{topologies}} \int \frac{\mathcal{D}(\text{geometry})\mathcal{D}(\text{coordinates})}{\text{Vol}(\text{symmetry group})} \int_{\sigma} \prod_{i=1}^n d^2 z_i \mathcal{V}(k_i, \epsilon_i; z_i, \bar{z}_i) e^{-S}. \quad (2.6.1)$$

Physically distinct surfaces are described by moduli (and also supermoduli for genus $g \geq 2$) all of which need to be integrated over. As mentioned earlier in the context of the one-loop partition function, at this order the modulus τ was integrated over the fundamental domain, a region in the upper half-plane which notably does not include the origin, resulting in the absence of any UV divergences in the amplitude. For surfaces of genus $g \leq 1$ it is also necessary to deal with the presence of conformal Killing vectors (CKVs). This may be done by fixing the position of some of the vertex operators, three for $g = 0$ or one for $g = 1$. Meanwhile, CKVs are absent for all surfaces with $g \geq 2$.

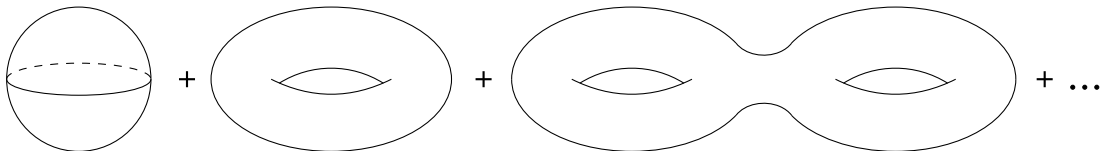

Figure 2.5: Perturbative series expansion of the genus g .

For the bosonic string we consider the worldsheet as a Riemann surface while for superstrings we have a super-Riemann surface. Nevertheless, for genus $g = 0, 1$ the difference is inconsequential and the distinctiveness is only apparent when $g \geq 2$, due to the appearance of supermoduli. The dimension of moduli space for genus g is given by

$$\dim(\mathfrak{M}_g) = \begin{cases} (0|0), & g = 0 \\ (1|0), & g = 1, \delta = \text{even} \\ (1|1), & g = 1, \delta = \text{odd} \\ (3g - 3|2g - 2), & g \geq 2 \end{cases} \quad (2.6.2)$$

Note that there is actually a supermodulus at genus 1 for the odd spin structure only, however this is easily dealt with. If we specify to two-loop order, there are now three moduli and two supermoduli. The way to proceed is by integrating over the odd Grassmann-valued supermoduli leaving only integrals over the three remaining even moduli. Great care must be taken during this process to ensure the results obtained are independent of the choice of gauge, a problem which plagued many of the early attempts. The correct way to proceed is by assigning the three complex moduli to the three independent entries of the superperiod matrix of the genus 2 super-Riemann surface. This ensures invariance under local worldsheet supersymmetry while the supermoduli are integrated over.

2.6.2 Vertex operators

Vertex operators are worldsheet operators representing the emission or absorption of a physical on-shell string mode from a particular point on the worldsheet. Physical states and vertex operators exhibit a one-to-one mapping and each closed string vertex operator is accompanied by a string coupling constant g_s . A given incoming or outgoing state j has a D -momentum k^μ and a corresponding local vertex operator $\mathcal{V}_j(k)$.

Consider compactifying the spatial coordinate σ so that $\sigma = \sigma + 2\pi$ and define the complex coordinate

$$w = \sigma + i\tau. \quad (2.6.3)$$

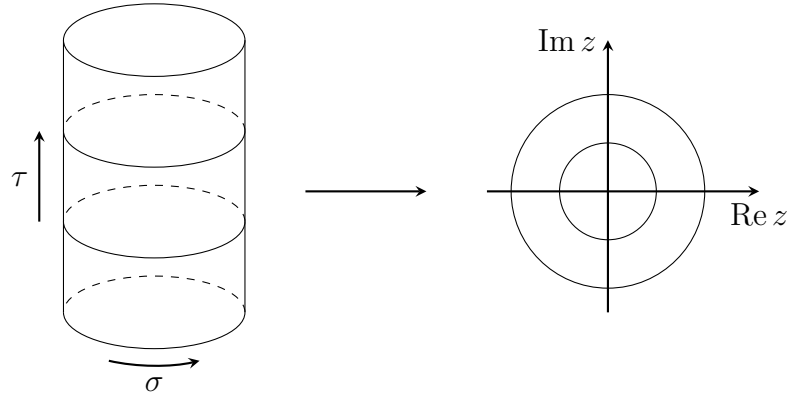

Figure 2.6: Map from cylinder to the complex plane.

The semi-infinite cylinder maps onto the unit disk with coordinate $z = e^{-iw}$ as in Figure 2.6. This implies that incoming states from the infinite past are mapped onto the origin on the complex plane for the coordinate z . Specifying the initial state is equivalent to defining a local operator associated with the state, known as a vertex operator, at the origin.

The vertex operators for Kähler and complex structure moduli in the natural picture are given by

$$V_{T_i}^{-1} = v_{IJ}^{(T_i)} : e^{-\phi} \psi^I \bar{\partial} X^J e^{ik \cdot X} :, \quad (2.6.4)$$

where ϕ is a bosonic field coming from the bosonisation of the superconformal ghosts and where

$$v_{IJ}^{(T_i)} = \frac{\partial}{\partial T_i} (G_{IJ} + B_{IJ}). \quad (2.6.5)$$

The superscript -1 is referred to as the ϕ -charge, or picture, and is given by the power of the factor of e^ϕ in the vertex operator. For one-loop closed string amplitudes it is necessary for the total ϕ -charge to equal zero and so we need some method of altering the ϕ -charges of the vertex operators. This is achieved through the use of the picture changing operation, given by

$$\mathcal{V}^{i+1}(k, z) = \lim_{w \rightarrow z} e^\phi T_F(w) \mathcal{V}_i(z). \quad (2.6.6)$$

Therefore, the vertex operators for Kähler and complex structure moduli in the

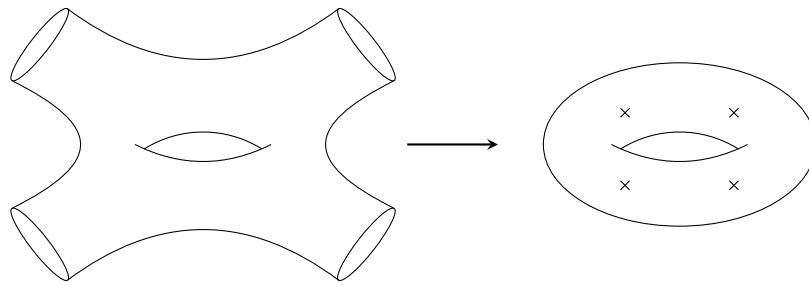

Figure 2.7: One-loop 4-point scattering.

zero picture are given by

$$V_{T_i}^0 = v_{IJ}^{(T_i)} (\partial X^I + ik \cdot \psi \psi^I) \bar{\partial} X^J e^{ik \cdot X}. \quad (2.6.7)$$

Note that for higher loop superstring amplitudes the vertex operators need to be modified in order for the result to be consistent under the integration of the supermoduli. The only two-loop amplitude we will consider in this thesis is the one with zero vertex operator insertions and so we will not go into further details.

2.7 Supergravity as an effective theory

In order to examine many phenomenological aspects of particular superstring theories, one can examine the low-energy effective theory, which is typically some supergravity theory. Supergravity can be obtained by taking a supersymmetric quantum field theory and promoting supersymmetry to a local symmetry, which results in the manifestation of gravity within the theory. Therefore, it is a natural candidate for an effective theory since string theory necessarily includes gravity.

Consider $\mathcal{N} = 1$ supergravity which includes vector multiplets containing vectors and their Majorana gaugini, chiral multiplets containing a complex scalar and a Weyl spinor, and a linear multiplet containing an antisymmetric tensor, a scalar and a Weyl fermion (Note that the linear multiplet can be dualised into a chiral multiplet). Any given supergravity theory can be determined by three independent functions, the Kähler potential K , the superpotential W , and the holomorphic gauge-kinetic function f_a . The bosonic part of the Lagrangian is given by

$$\mathcal{L}_{\mathcal{N}=1} = -\frac{R}{2} - G_{i\bar{j}} D_\mu \phi^i D^\mu \bar{\phi}^{\bar{j}} - V(\phi, \bar{\phi}) + \sum_a \left(\frac{1}{4g_a^2} \text{Tr}[F_{\mu\nu} F^{\mu\nu}]_a + \frac{\theta_a}{4} \text{Tr}[F_{\mu\nu} \tilde{F}^{\mu\nu}]_a \right), \quad (2.7.1)$$

where the Kähler metric $G_{i\bar{j}} = \partial_i \partial_{\bar{j}} K(\phi, \bar{\phi})$, and ϕ^i are complex scalars of chiral multiplets. The gauge couplings and θ -angles depend on the moduli through the gauge-kinetic function f_a ,

$$\frac{1}{g_a^2} = \text{Re } f_a(\phi), \quad \theta_a = -\text{Im } f_a(\phi). \quad (2.7.2)$$

Assuming there is no D-term contribution, the scalar potential is given by

$$V = e^K \left(D_i W G^{i\bar{j}} \bar{D}_{\bar{j}} \bar{W} - 3|W|^2 \right), \quad (2.7.3)$$

where

$$D_i W = \frac{\partial W}{\partial \phi^i} + \frac{\partial K}{\partial \phi^i} W. \quad (2.7.4)$$

The action is invariant under Kähler transformations given by

$$K \rightarrow K + \Lambda(\phi) + \bar{\Lambda}(\bar{\phi}), \quad W \rightarrow We^{-\Lambda}, \quad f_a \rightarrow f_a. \quad (2.7.5)$$

In the following chapter, we will consider a theory with two dimensions compactified on a \mathbb{T}_2 torus, for which the tree-level Kähler potential is given by

$$K = -\log \left[-(T - \bar{T})(U - \bar{U}) - (B + \bar{C})(\bar{B} - C) \right], \quad (2.7.6)$$

where T and U are the Kähler and complex structure moduli respectively, and the scalars B and C are matter fields or Wilson line moduli.

An important property of these effective theories is that the Lagrangian of the is invariant under target space $SL(2, \mathbb{Z})$ modular transformations of both the Kähler and complex structure moduli. This symmetry is inherited from the T -duality present in the full string theory. If the Kähler modulus transforms as

$$T \rightarrow \frac{aT + b}{cT + d}, \quad a, b, c, d, \in \mathbb{Z}, \quad ad - bc = 1, \quad (2.7.7)$$

then the matter fields transform as

$$B \rightarrow \frac{B}{cU + d}, \quad C \rightarrow \frac{B}{cU + d}, \quad (2.7.8)$$

while the complex structure modulus transforms as

$$U \rightarrow U - \frac{c}{cT + d} BC. \quad (2.7.9)$$

The Kähler modulus T transforms similarly under $SL(2, \mathbb{Z})$ transformations of U , while there is also a symmetry under the interchange $T \leftrightarrow U$. One can show that the tree-level Kähler potential given in Equation 2.7.6 is indeed invariant up to a Kähler transformation,

$$K \rightarrow K + \log(cT + d) + \log(c\bar{T} + d). \quad (2.7.10)$$

The modular symmetries restrain the form that functions such as the Kähler potential can take. If we determine corrections to this quantity from calculations in the string theory, these symmetries provide a useful check on the results obtained.

Chapter 3

Shift-symmetries at higher order

3.1 Introduction

An interesting property of the effective field theories that emerge from string theory is that they often possess non-compact shift-symmetries. These are symmetries under which two fields, B and C say, transform as $B \rightarrow B + c$, $C \rightarrow C - \bar{c}$. The Kähler potential of a theory with such a symmetry, written as a power series expansion in the matter fields, has to take the form

$$K = G + |B + \bar{C}|^2 f + \dots, \quad (3.1.1)$$

where the coefficients G and f will generally have some dependence on the Kähler and complex structure moduli of the compactification. Consequently the orthogonal combination $B - \bar{C}$ remains massless. An observation made by [8–15] and discussed further in [16–19], is that these seemingly ad-hoc continuous symmetries appear naturally at tree-level due to the underlying discrete modular symmetries of the full string theory. They were initially suggested as a way of directly protecting Higgs masses. Furthermore it has been observed that shift symmetries may be linked to the apparent vanishing of the Higgs self-coupling at intermediate scales [16–19].

It is an unfortunate fact that the shift-symmetries in question are only accidental and global. One does not expect them to be preserved, even at the string

scale, because the full string theory does not respect them. Nevertheless an interesting question is how quickly such symmetries are eroded in perturbation theory, and whether there is a parametric way of controlling them or possibly even restoring them in the string thresholds. Although there has been some work done on one-loop corrections to the effective μ -term for example [10, 11], this particular issue has not to our knowledge been explored in any detail.

Although it is a generic expectation that non-compact shift-symmetries afford no more than a loop's worth of protection for any would-be Higgs field, the purpose of this chapter is to show that in the limit of certain asymmetric compactifications the symmetries are preserved. Indeed they can be made parametrically good at the string scale.

There is a simple general argument that supports the restoration of shift-symmetries in asymmetric compactifications which is as follows. Consider the class of heterotic string theories that exhibit $\mathcal{N} = 1$ supergravity as their low energy effective field theories, and have a $\mathbb{T}_2/\mathbb{Z}_2$ orbifold subfactor in their compactification (although almost certainly the heuristic argument we are about to present applies more generally). The Kähler and complex structure moduli of the $\mathbb{T}_2/\mathbb{Z}_2$ are denoted T, U . We will consider our theory in the presence of two continuous Wilson lines associated with each of the two compact dimensions of the T^2 , a linear combination of which corresponds to the matter fields B and C . For the untwisted components we are then interested in whether the coefficients $H_{BC}(T, U)$, $Z_{B\bar{B}}(T, U)$ and $Z_{C\bar{C}}(T, U)$ in

$$K = G + Z_{C\bar{C}}C\bar{C} + Z_{B\bar{B}}B\bar{B} + (H_{BC}CB + \text{c.c.}) + \dots, \quad (3.1.2)$$

exhibit the correct relation at one-loop order, so that it can be cast in the form of Equation 3.1.1.

At tree-level, the Kähler potential is well known for such models, and is given by [8–11],

$$K = -\log \left[-(T - \bar{T})(U - \bar{U}) - (B + \bar{C})(\bar{B} + C) \right], \quad (3.1.3)$$

clearly exhibiting the shift-symmetry in question. To see why we expect the

shift-symmetry to be preserved at higher order in certain limits, we recall the particular linear combination of complex Wilson lines A^1 and A^2 (where upstairs indices label two different Cartan subalgebra $U(1)$'s) giving rise to B and C :

$$B = -\frac{1}{\sqrt{2}}(iA^1 + A^2), \quad C = -\frac{1}{\sqrt{2}}(iA^1 - A^2). \quad (3.1.4)$$

These are each further related to two real Wilson lines as $A^a = U\mathcal{A}_1^a - \mathcal{A}_2^a$, where the lower indices label the two \mathbb{T}_2 cycles). The real Wilson lines represent shifts in the internal momentum/charge lattice (a.k.a. Narain lattice) of the compactification, so they can be thought of as directly corresponding to the original stringy degrees of freedom. The crucial point is that in the highly asymmetric ($U_2 \gg 1$) limit, A^a is dominated by the term $iU_2\mathcal{A}_1^a$, where in our convention $U = U_1 + iU_2$. Comparing the expressions for \bar{B} and C in this limit, we see that they are both given by,

$$\bar{B}, C = \frac{U_2}{2}(\mathcal{A}_1^1 + i\mathcal{A}_1^2) + \mathcal{O}(1). \quad (3.1.5)$$

Not surprisingly at large U_2 the two Wilson lines are both dominated by one of the cycles and they become degenerate. The general expectation therefore is that all radiative corrections to the Kähler potential exhibit degeneracy for B and C in the limit of large U_2 . In particular one would naturally expect the coefficients of $B\bar{B}$ and BC to become degenerate *to all orders*.

We would like to test this heuristic expectation, and in order to do so we will compute the relevant corrections to the Kähler potential at one-loop, allowing us to determine and study the coefficients $H_{BC}(T, U)$, $Z_{B\bar{B}}(T, U)$ and $Z_{C\bar{C}}(T, U)$ appearing in Equation 3.1.2. It will be sufficient to find the one-loop corrections to the Kähler potential up to quadratic order in the untwisted matter fields. Therefore we will proceed by computing the CP even part of one-loop two-point functions involving the moduli T and U as the external states but with the continuous Wilson line moduli in place. We can then focus on the $\mathcal{O}(k^2)$ piece of the amplitude, and compare it with the corresponding kinetic terms in the

effective supergravity Lagrangian. Those terms are of the form,

$$K_{i\bar{j}}\partial\phi^i\partial\phi^{\bar{j}}, \quad (3.1.6)$$

so essentially it is the Kähler metric $K_{i\bar{j}}$ that we compute, from which one could then hope to determine the Kähler potential. This method was utilised in [20] to calculate one-loop corrections to the Kähler potential for type-II strings compactified on orientifolds, and a similar procedure was also performed for heterotic strings in [21]. Furthermore, loop corrections to low-energy effective theories of heterotic strings have also been investigated in [22, 23].

The bulk of the computation is carried out in the next section: we first introduce the notation for the moduli and partition function in the presence of Wilson lines, and then consider the two-point amplitude between moduli T and \bar{T} , evaluating the relevant correlation functions. Then we compute the integrals over τ by the unfolding method. In section 3 we use the results to write a consistent expression for the one-loop corrections to the Kähler potential up to quadratic order in the Wilson lines, and confirm the general picture outlined above. Indeed in theories of this kind we find that $\varepsilon = 1/(T_2 + U_2)$ is a small parameter governing shift-symmetry violation in the limit that $U_2 \gg 1$, while conversely when $U_2 \sim 1$ there is no shift-symmetry at all in the effective theory at the string scale¹.

3.2 The calculation

3.2.1 Moduli definitions, vertex operators and partition function

Let us begin by gathering some necessary ingredients. As per the introduction, we will focus on models where the compactification includes an orbifolded two-torus, and focus on the contributions that arise due to the presence of the two real

¹Note that there is *no-scale* symmetry which sets all the relevant scalar masses zero at tree-level, but shift-symmetry itself is absent.

non-zero Wilson lines \mathcal{A}_1^a and \mathcal{A}_2^a . These are mixed with the Kähler and complex structure moduli in their relation to the metric and antisymmetric tensor; the required relation is [8, 9, 24]

$$T = i\sqrt{G} + B_{12} + \frac{1}{2} \sum_a A^a \frac{A^a - \bar{A}^a}{U - \bar{U}}, \quad (3.2.1)$$

where, as above, the complex Wilson lines are defined as $A^a = U\mathcal{A}_1^a - \mathcal{A}_2^a$. The U modulus is unchanged by the presence of Wilson lines and so it can simply be defined in the usual way as,

$$U = \frac{1}{G_{11}} (i\sqrt{G} + G_{12}). \quad (3.2.2)$$

From the above, we can then write the metric G_{IJ} and antisymmetric tensor B_{IJ} for the torus as follows,

$$G_{IJ} = \left(\frac{T - \bar{T}}{U - \bar{U}} - \frac{(A^a - \bar{A}^a)^2}{2(U - \bar{U})^2} \right) \begin{pmatrix} 1 & U_1 \\ U_1 & |U|^2 \end{pmatrix}, \quad (3.2.3)$$

$$B_{IJ} = \left(\frac{T + \bar{T}}{2} - \frac{(A^a - \bar{A}^a)(A^a + \bar{A}^a)}{4(U - \bar{U})} \right) \begin{pmatrix} 0 & 1 \\ -1 & 0 \end{pmatrix}. \quad (3.2.4)$$

The specific calculation we will perform is the two-point function between the moduli T and \bar{T} , so next we need the corresponding vertex operators. In terms of real coordinates, the vertex operators for the moduli in the zero picture are given by [1, 25],

$$V_{T^i} = v_{IJ}^{(T^i)} : (\partial X^I + ik \cdot \psi \psi^I) \bar{\partial} X^J e^{ik \cdot X} :, \quad (3.2.5)$$

where T^i denotes both the moduli T and U , and,

$$v_{IJ}^{(T^i)} = \frac{\partial}{\partial T^i} (G_{IJ} + B_{IJ}). \quad (3.2.6)$$

We find it more convenient to use a similar notation to [20], and to write the

vertex operators in terms of the complex coordinates Z and Ψ defined as,

$$\begin{aligned} Z &= \sqrt{\frac{T_2 + \frac{(A-\bar{A})^2}{8U_2}}{2U_2}}(X^5 + \bar{U}X^6), & \bar{Z} &= \sqrt{\frac{T_2 + \frac{(A-\bar{A})^2}{8U_2}}{2U_2}}(X^5 + UX^6), \\ \Psi &= \sqrt{\frac{T_2 + \frac{(A-\bar{A})^2}{8U_2}}{2U_2}}(\psi^5 + \bar{U}\psi^6), & \bar{\Psi} &= \sqrt{\frac{T_2 + \frac{(A-\bar{A})^2}{8U_2}}{2U_2}}(\psi^5 + U\psi^6). \end{aligned} \quad (3.2.7)$$

The vertex operator for the T modulus can then be written in the zero picture as,

$$V_T = -\frac{i}{T_2 + \frac{(A-\bar{A})^2}{8U_2}}(\partial Z - ik \cdot \psi\Psi)\bar{\partial}\bar{Z}e^{ik\cdot X}, \quad (3.2.8)$$

while for the U modulus we have,

$$V_U = -\frac{i(A-\bar{A})^2}{8U_2^2\left(T_2 + \frac{(A-\bar{A})^2}{8U_2}\right)}(\partial Z - ik \cdot \psi\Psi)\bar{\partial}\bar{Z}e^{ik\cdot X} + \frac{i}{U_2}(\partial Z - ik \cdot \psi\Psi)\bar{\partial}Ze^{ik\cdot X}. \quad (3.2.9)$$

We shall also need the internal partition function associated with the torus. With the inclusion of the Wilson lines, the relevant contribution can be written as [24],

$$\mathcal{Z}_{\vec{m}, \vec{n}}(T, U, \vec{\mathcal{A}}^a) = \frac{T_2 + \frac{(A-\bar{A})^2}{8U_2}}{\tau_2} \sum_{\vec{m}, \vec{n} \in \mathbb{Z}} e^{-S(\vec{m}, \vec{n})} \sum_{Q^a} q^{(Q^a + \vec{\mathcal{A}}^a \cdot \vec{n})^2/2} e^{-2\pi i \vec{\mathcal{A}}^a \cdot \vec{m} (Q^a + \vec{\mathcal{A}}^a \cdot \vec{n}/2)}, \quad (3.2.10)$$

where,

$$S(\vec{m}, \vec{n}) = \frac{\pi}{\tau_2}(G_{IJ} + B_{IJ})(m_I + n_I\tau)(m_J + n_J\bar{\tau}), \quad (3.2.11)$$

and Q^a are the elements of the charge/momentum lattice on the gauge side that are shifted by the Wilson lines. Hence only q appears here: the full partition function includes an additional factor we shall refer to as $\mathcal{Z}_{rest}(q, \bar{q})$ that is unshifted by the Wilson lines, which incorporates the remaining degrees of freedom (for example those coming from the remaining K_3 factor in the compactification).

3.2.2 Two-point amplitudes

As previously mentioned, we will obtain the one-loop corrections to the Kähler potential by computing one-loop amplitudes between the various modulus and

anti-modulus pairs, specifically those corresponding to corrections to $K_{T_i\bar{T}_j}$. This will then allow us to determine the form of the Kähler potential itself. The amplitudes we need are therefore of the form,

$$\int_{\mathcal{F}} \frac{d^2\tau}{\tau_2^2} \int d^2z \langle V_{T_i}(k, z) V_{\bar{T}_j}(-k, 0) \rangle \mathcal{Z}_{\bar{m}, \bar{n}} \mathcal{Z}_{\text{rest}}. \quad (3.2.12)$$

The correlation function between the vertex operators is

$$\langle V_T V_{\bar{T}} \rangle = - \frac{1}{\left(T_2 + \frac{(A-\bar{A})^2}{8U_2}\right)^2} \langle (\partial Z - ik \cdot \psi \Psi) \bar{\partial} \bar{Z} e^{ik \cdot X} (\partial \bar{Z} + ik \cdot \psi \bar{\Psi}) \bar{\partial} \bar{Z} e^{-ik \cdot X} \rangle. \quad (3.2.13)$$

In a supersymmetric theory, the only non-zero contribution to the amplitude arises when all four of the fermionic coordinates are contracted, because the remaining pieces are spin independent and will therefore vanish by the non-renormalisation theorem (i.e. they get multiplied by the partition function which is zero). Even in non-supersymmetric theories, as in [7], the remaining pieces would be proportional to the cosmological constant and hence suppressed if the latter is suppressed. Of course the vanishing of the cosmological constant beyond one-loop in such theories is very much still under investigation and so the stability of such models can not be guaranteed. Nevertheless, for the models under consideration we need only consider the spin dependent term,

$$- \frac{1}{4 \left(T_2 + \frac{(A-\bar{A})^2}{8U_2}\right)^2} k^2 \langle \psi \cdot \psi \rangle \langle \Psi \bar{\Psi} \rangle \langle \bar{\partial} \bar{Z} \bar{\partial} Z \rangle. \quad (3.2.14)$$

For the bosonic correlation function we will only need to consider the contributions arising from the zero-modes, for which we have,

$$\begin{aligned} \langle \bar{\partial} Z(z) \bar{\partial} \bar{Z}(0) \rangle &= \sum_{\bar{m}, \bar{n}} \frac{\pi^2 \left(T_2 + \frac{(A-\bar{A})^2}{8U_2}\right)}{\tau_2^2 U_2} [m_1 + n_1 \bar{\tau} + U(m_2 + n_2 \bar{\tau})] \\ &\quad \times [m_1 + n_1 \bar{\tau} + \bar{U}(m_2 + n_2 \bar{\tau})]. \end{aligned} \quad (3.2.15)$$

Given the lack of z -dependence in the above, in order to compute the integral over z we need only take into account the contributions from the fermionic correlation

functions. The integral is calculated as in [7]:

$$\begin{aligned}
I &= \int d^2z \langle \psi^\rho \psi^\sigma \rangle \langle \Psi \bar{\Psi} \rangle \\
&= \int d^2z \left(\wp + 4\pi i \partial_\tau \log \sqrt{\vartheta_{ab}(0)\vartheta_{cd}(0)}/\eta(\tau) \right) \\
&= \int d^2z \left(-\partial_z^2 \log \vartheta_1(z) + 4\pi i \partial_\tau \log \sqrt{\vartheta_{ab}(0)\vartheta_{cd}(0)} \right) \\
&= \pi + 4\pi i \tau_2 \partial_\tau \log \sqrt{\vartheta_{ab}(0)\vartheta_{cd}(0)},
\end{aligned} \tag{3.2.16}$$

where a, b and c, d refer to the spin structures of ψ and Ψ respectively, which is being summed over. Note that, analogously to the usual beta function calculation, the second term can also be written as $2\pi i \partial_\tau (Z_\psi Z_\Psi)$. Here, we can now take note of the fact that our amplitude includes a sum over all of the spin structures. The spin independent contribution therefore vanishes after the sum is taken, and so we are left only with the term proportional to τ_2 .

What remains is to calculate is the following integral,

$$\begin{aligned}
&\frac{-\pi^2 k^2}{4 \left(T_2 + \frac{(A-\bar{A})^2}{8U_2} \right) U_2} \int_{\mathcal{F}} \frac{d^2\tau}{\tau_2^3} \sum_{\vec{m}, \vec{n}} [m_1 + n_1 \bar{\tau} + U(m_2 + n_2 \bar{\tau})] \\
&\quad \times [m_1 + n_1 \bar{\tau} + \bar{U}(m_2 + n_2 \bar{\tau})] \mathcal{Z}_{\vec{m}, \vec{n}} \tilde{\mathcal{Z}}_{\text{rest}}.
\end{aligned} \tag{3.2.17}$$

where now $\tilde{\mathcal{Z}}_{\text{rest}}$ is given by $\mathcal{Z}_{\text{rest}}$ with the inclusion of the extra spin dependent piece from the fermion correlators as given by Equation 3.2.16. Note that the factor of τ_2 has already been extracted from this additional piece, and $\tilde{\mathcal{Z}}_{\text{rest}}$ also contains the sum over spin structures. We now proceed to expand this expression in terms of the Wilson lines. We can then focus on the quadratic terms, and subsequently evaluate the corresponding integrals.

3.2.3 Modular integrals

In order to compute the modular integrals arising from the two-point functions, we can use the unfolding technique of [26] (also utilised in [21, 27, 28]), in which the integral is split into representative orbits of $SL(2, \mathbb{Z})$. This decomposes the integral over the fundamental domain into simpler integration regions, depending on the type of orbit. There are three types of orbits, the zero orbit, degenerate

orbits and non-degenerate orbits. We begin by writing the partition function in terms of complex Wilson lines in the form [24, 29]

$$\mathcal{Z}_{\vec{m}, \vec{n}}(T, U, \vec{A}^a) = \frac{T_2 + \frac{(A-\bar{A})^2}{8U_2}}{\tau_2} \sum_{Q^a} q^{Q \cdot Q/2} e^{\mathcal{G}(M, \tau)}, \quad (3.2.18)$$

where

$$\begin{aligned} \mathcal{G}(M, \tau) = & \frac{-\pi \left(T_2 + \frac{(A-\bar{A})^2}{8U_2} \right)}{\tau_2 U_2} |\mathcal{M}|^2 - 2\pi i T \det M + \frac{\pi}{U_2} (Q \cdot A \tilde{\mathcal{M}} - Q \cdot \bar{A} \mathcal{M}) \\ & - \frac{\pi n_2}{2U_2} (A \cdot A \tilde{\mathcal{M}} - \bar{A} \cdot \bar{A} \mathcal{M}) - \frac{i\pi (A - \bar{A})^2}{4U_2^2} (n_1 + n_2 \bar{U}) \mathcal{M}, \end{aligned} \quad (3.2.19)$$

and

$$M = \begin{pmatrix} n_1 & m_1 \\ n_2 & m_2 \end{pmatrix}, \quad \mathcal{M} = \begin{pmatrix} 1 & U \end{pmatrix} M \begin{pmatrix} \tau \\ 1 \end{pmatrix}, \quad \tilde{\mathcal{M}} = \begin{pmatrix} 1 & \bar{U} \end{pmatrix} M \begin{pmatrix} \tau \\ 1 \end{pmatrix}. \quad (3.2.20)$$

The orbits of $SL(2, \mathbb{Z})$ are then defined in terms of the matrix M .

Zero orbit

This orbit consists only of the matrix $M = 0$, with the integration being performed over the fundamental domain. However its contribution trivially vanishes due to the presence of the overall factor from the bosonic zero modes.

Degenerate orbits

These consist of matrices of the form,

$$M = \begin{pmatrix} 0 & j \\ 0 & p \end{pmatrix},$$

where the sum is over all integer values $(j, p) \neq (0, 0)$ and the integration is extended from the fundamental domain to the half-strip, $E = \{-\frac{1}{2} < \tau_1 < \frac{1}{2}, \tau_2 > 0\}$. The integral we need to evaluate is of the form,

$$\mathcal{I}_1 = \frac{-\pi^2}{4 \left(T_2 + \frac{(A-\bar{A})^2}{8U_2} \right) U_2} \int_E \frac{d^2\tau}{\tau_2^3} \sum_{(j,p) \neq (0,0)} |j + pU|^2 \mathcal{Z}_{(j,p),(0,0)} \tilde{\mathcal{Z}}_{\text{rest}}, \quad (3.2.21)$$

where the partition function becomes,

$$\begin{aligned} \mathcal{Z}_{(j,p),(0,0)} &= \frac{T_2 + \frac{(A-\bar{A})^2}{8U_2}}{\tau_2} \exp \left[-\frac{\pi}{\tau_2 U_2} \left(T_2 + \frac{(A-\bar{A})^2}{8U_2} \right) |j + pU|^2 \right] \\ &\times \sum_{Q^a} q^{Q \cdot Q/2} \exp \left[\frac{\pi}{U_2} [Q \cdot A(j + p\bar{U}) - Q \cdot \bar{A}(j + pU)] \right]. \end{aligned} \quad (3.2.22)$$

As mentioned, we are primarily interested in calculating the Kähler potential only up to quadratic order in the Wilson lines. Therefore, we can write the above as an expansion in A^a and \bar{A}^a , and focus only on the relevant terms.

To begin, we can evaluate the Wilson line independent part of Equation 3.2.21:

$$\begin{aligned} \mathcal{I}'_1 &= \frac{-\pi^2}{4U_2} \int_E \frac{d^2\tau}{\tau_2^4} \sum_{\substack{(j,p) \neq (0,0) \\ Q^a}} |j + pU|^2 e^{-\frac{\pi T_2}{\tau_2 U_2} |j+pU|^2} q^{Q \cdot Q/2} \tilde{\mathcal{Z}}_{\text{rest}} \\ &= c_1 \frac{4i}{\pi(T - \bar{T})^3} E(U, 2) + \dots, \end{aligned} \quad (3.2.23)$$

where we have written only the most dominant contribution, and c_1 is some constant of order one that we do not calculate. It is dependent on the coefficients of the power series in q and \bar{q} in $q^{Q \cdot Q/2} \tilde{\mathcal{Z}}_{\text{rest}}$, the sum over spin structures, and also on a restricted sum over the lattice vectors Q^a . In the above, the real analytic Eisenstein series are defined as,

$$E(U, s) = \sum'_{l,m} \frac{U_2^s}{|l + mU|^{2s}}, \quad (3.2.24)$$

where the prime means we do not include the case when $l_1 = l_2 = 0$ in the sum.

We now extract the terms proportional to $A^a \bar{A}^a$ and $A^a A^a$. The former term is given by,

$$\mathcal{I}_1^{A, \bar{A}} = \frac{-\pi^3}{4U_2^3} \int_E \frac{d^2\tau}{\tau_2^4} \sum_{\substack{(j,p) \neq (0,0) \\ Q^a}} F(A, \bar{A}) |j + pU|^2 e^{-\frac{\pi T_2}{\tau_2 U_2} |j+pU|^2} q^{Q \cdot Q/2} \tilde{\mathcal{Z}}_{\text{rest}}, \quad (3.2.25)$$

where

$$F(A, \bar{A}) = \left(\frac{1}{4\tau_2} A^a \bar{A}^a - \pi(Q \cdot A)(Q \cdot \bar{A}) \right) |j + pU|^2. \quad (3.2.26)$$

The integral over τ can be performed with the result

$$\begin{aligned} \tilde{\mathcal{I}}_1^{A,\bar{A}} &= \frac{-12ic_1 E(U, 2)}{\pi(T - \bar{T})^4(U - \bar{U})} \\ &\quad + \frac{4\pi^2 c_2}{(T - \bar{T})^3(U - \bar{U})} \left[3 - 2 \log(-e^{-2\gamma} \pi(T - \bar{T})(U - \bar{U}) |\eta(U)|^4) \right], \end{aligned} \quad (3.2.27)$$

where γ is the Euler-Mascheroni constant and $\mathcal{I}_1^{A,\bar{A}} = \tilde{\mathcal{I}}_1^{A,\bar{A}} A \bar{A}$. Note that in order to arrive at the above result it is necessary to regulate the divergent parts of the integral (proportional to τ_2^{-4} in the integrand) that have arisen because we have exchanged the order of summation and integration. These can be dealt with by including an additional factor of $\tau_2^{-\epsilon}$, performing the integration, evaluating the sum and extracting the ϵ independent piece as described in [30, 31]. Alternatively, one finds the same result using the regularisation procedure of [26]. As before, the constants c_1 and c_2 come from the coefficients of the power series in q and \bar{q} in $\mathcal{Z}_{\text{rest}}$, the sum over spin structures, and from the sum over lattice vectors Q^a ; they are completely independent of moduli.

Similarly, the expression we need for the term proportional to $A^a A^a$ is,

$$\mathcal{I}_1^{A,A} = \frac{-\pi^3}{4U_2^3} \int_E \frac{d^2\tau}{\tau_2^4} \sum_{\substack{(j,p) \neq (0,0) \\ Q^a}} F(A, A) |j + pU|^2 e^{-\frac{\pi T_2}{\tau_2 U_2} |j + pU|^2} q^{Q \cdot Q/2} \tilde{\mathcal{Z}}_{\text{rest}}, \quad (3.2.28)$$

$$F(A, A) = \left(-\frac{1}{8\tau_2} |j + pU|^2 A^a A^a + \frac{\pi}{2} (j + p\bar{U})^2 (Q \cdot A)^2 \right), \quad (3.2.29)$$

where again the integral over τ can be performed with suitable regularisation and we obtain the result,

$$\tilde{\mathcal{I}}_1^{A,A} = \frac{6ic_1 E(U, 2)}{\pi(T - \bar{T})^4(U - \bar{U})} + \frac{4\pi^2 c_2}{(T - \bar{T})^3} \left[2\partial_U \log \eta(U) + \frac{1}{(U - \bar{U})} \right]. \quad (3.2.30)$$

Finally, the result for the term proportional to $\bar{A}^a \bar{A}^a$ is just given by the complex conjugate of $\tilde{\mathcal{I}}_1^{A,A}$.

Non-degenerate orbits

These consist of matrices of the form,

$$M = \pm \begin{pmatrix} k & j \\ 0 & p \end{pmatrix},$$

where the sum is over $0 \leq j < k$, $p \neq 0$ and the integration is over the upper half plane \mathbb{H} . The expression to evaluate is of the form,

$$\mathcal{I}_2 = \frac{-\pi^2}{4 \left(T_2 + \frac{(A-\bar{A})^2}{8U_2} \right) U_2} \int_{\mathbb{H}} \frac{d^2\tau}{\tau_2^4} \sum_{\substack{0 \leq j < k \\ p \neq 0}} \tilde{Q}_U \tilde{Q}_{\bar{U}} \mathcal{Z}_{(j,p),(k,0)} \tilde{\mathcal{Z}}_{\text{rest}}, \quad (3.2.31)$$

where the torus partition function is,

$$\begin{aligned} \mathcal{Z}_{(j,p),(k,0)} &= \frac{T_2 + \frac{(A-\bar{A})^2}{8U_2}}{\tau_2} \sum_{Q^a} q^{Q \cdot Q/2} \exp \left[\frac{\pi}{U_2} (Q \cdot A Q_{\bar{U}} - Q \cdot \bar{A} Q_U) \right] \\ &\times \exp \left[-\frac{\pi T_2}{U_2 \tau_2} |Q_U|^2 - 2\pi i T k p - \frac{\pi(A-\bar{A})^2}{8U_2^2 \tau_2} |Q_U|^2 - \frac{\pi i (A-\bar{A})^2}{4U_2^2} k Q_U \right] \end{aligned} \quad (3.2.32)$$

and where,

$$\begin{aligned} Q_U &= (j + k\tau + pU), \\ Q_{\bar{U}} &= (j + k\tau + p\bar{U}), \\ \tilde{Q}_U &= (j + k\bar{\tau} + pU), \\ \tilde{Q}_{\bar{U}} &= (j + k\bar{\tau} + p\bar{U}). \end{aligned} \quad (3.2.33)$$

As for the degenerate orbits, we will evaluate the first few terms in a series expansion of Equation 3.2.31 in the Wilson lines. The result for the Wilson line independent part (after summing over j and p) is,

$$\begin{aligned} \mathcal{I}'_2 &= \frac{-\pi^2}{4U_2} \int_{\mathbb{H}} \frac{d^2\tau}{\tau_2^4} \sum_{\substack{0 \leq j < k \\ p \neq 0, Q_a}} \tilde{Q}_U \tilde{Q}_{\bar{U}} e^{-2\pi i T k p} e^{-\frac{\pi T_2}{\tau_2 U_2} |j+k\tau+pU|^2} q^{Q \cdot Q/2} \tilde{\mathcal{Z}}_{\text{rest}} \\ &= \frac{-4c_1}{(T - \bar{T})^3 (U - \bar{U})} \sum_{k>0} \left\{ 2k\pi T_2 \left[\text{Li}_2(q_T^k) + \text{Li}_2(\bar{q}_T^k) \right] + \left[\text{Li}_3(q_T^k) + \text{Li}_3(\bar{q}_T^k) \right] \right\} + \dots, \end{aligned} \quad (3.2.34)$$

where $q_T \equiv \exp(2\pi iT)$ and the polylogarithms $\text{Li}_n(z)$ are defined as,

$$\text{Li}_n(z) = \sum_{k>0} \frac{z^k}{k^n}. \quad (3.2.35)$$

In the above we are again only writing the dominant contributions. A more complete expression could be obtained along the lines of [21], but taking only these terms is sufficient for the comparison between the terms Z and H in the Kähler potential.

Now, as in the case for the degenerate orbits, we can look at the terms proportional to $A^a \bar{A}^a$. These are given by,

$$\mathcal{I}_2^{A, \bar{A}} = \frac{-\pi^3}{8U_2^3} \int_{\mathbb{H}} \frac{d^2\tau}{\tau_2^4} \sum_{\substack{0 \leq j < k \\ p \neq 0, Q_a}} F(A, \bar{A}) \tilde{Q}_U \tilde{Q}_{\bar{U}} e^{-2\pi i T k p} e^{-\frac{\pi T_2}{\tau_2 \bar{U}_2} |j+k\tau+pU|^2} q^{Q \cdot Q/2} \tilde{Z}_{\text{rest}}, \quad (3.2.36)$$

where,

$$F(A, \bar{A}) = \left[-2\pi Q_U Q_{\bar{U}} (Q \cdot A)(Q \cdot \bar{A}) + \left(ikQ_U + \frac{1}{2\tau_2} |Q_U|^2 \right) A^a \bar{A}^a \right]. \quad (3.2.37)$$

Performing the integration over τ and summing over j and p we obtain the result,

$$\begin{aligned} \tilde{\mathcal{I}}_2^{A, \bar{A}} = & \frac{4}{(T - \bar{T})^4 (U - \bar{U})^2} \left\{ c_1 \sum_{k>0} \left[\pi^2 (T - \bar{T})^2 k^2 \left[\log(1 - q_T^k) + \log(1 - \bar{q}_T^k) \right] \right. \right. \\ & \left. \left. - 3\pi ik(T - \bar{T}) \left[\text{Li}_2(q_T^k) + \text{Li}_2(\bar{q}_T^k) \right] + 3 \left[\text{Li}_3(q_T^k) + \text{Li}_3(\bar{q}_T^k) \right] \right] \right. \\ & \left. + \pi^2 ic_2 (T - \bar{T})^2 (U - \bar{U}) \left[\partial_T \log \eta(T) - \partial_{\bar{T}} \log \eta(\bar{T}) \right] \right. \\ & \left. - \pi^2 c_2 (T - \bar{T}) (U - \bar{U}) \log |\eta(T)|^4 \right\}. \quad (3.2.38) \end{aligned}$$

Moving on to the terms proportional to $A^a A^a$, we wish to calculate,

$$\mathcal{I}_2^{A, A} = \frac{-\pi^3}{16U_2^2} \int_{\mathbb{H}} \frac{d^2\tau}{\tau_2^4} \sum_{\substack{0 \leq j < k \\ p \neq 0, Q_a}} F(A, A) \tilde{Q}_U \tilde{Q}_{\bar{U}} e^{-2\pi i T k p} e^{-\frac{\pi T_2}{\tau_2 \bar{U}_2} |j+k\tau+pU|^2} q^{Q \cdot Q/2} \tilde{Z}_{\text{rest}}, \quad (3.2.39)$$

where,

$$F(A, A) = \left[2\pi Q_U^2 (Q \cdot A)(Q \cdot A) - \left(ikQ_U + \frac{1}{2\tau_2} |Q_U|^2 \right) A^a A^a \right]. \quad (3.2.40)$$

Again, computing the integration over τ and summing over j and p , we have the result,

$$\begin{aligned} \tilde{\mathcal{I}}_2^{A,A} = & \frac{-2c_1}{(T - \bar{T})^4 (U - \bar{U})^2} \sum_{k>0} \left\{ \pi^2 (T - \bar{T})^2 k^2 \left[\log(1 - q_T^k) + \log(1 - \bar{q}_T^k) \right] \right. \\ & \left. - 3\pi i k (T - \bar{T}) \left[\text{Li}_2(q_T^k) + \text{Li}_2(\bar{q}_T^k) \right] + 3 \left[\text{Li}_3(q_T^k) + \text{Li}_3(\bar{q}_T^k) \right] \right\}. \end{aligned} \quad (3.2.41)$$

3.3 One-loop Kähler potential

From the results of the previous section it is possible to establish the form of the one-loop corrections to the Kähler potential. In order to compare them to the corresponding kinetic terms in the supergravity Lagrangian, we Weyl rescale to the Einstein frame giving an additional factor

$$e^{2\Phi} = \frac{2i}{S - \bar{S}}. \quad (3.3.1)$$

We wish to express the Kähler potential in the form in Equation 3.1.2, with the Wilson lines and their complex conjugates defined as in Equation 3.1.4. Taking the sum over the index a we find, $\sum_a A^a \bar{A}^a = B\bar{B} + C\bar{C}$, and the one-loop corrections to the coefficients $Z_{B\bar{B}}$ and $Z_{C\bar{C}}$ both then satisfy,

$$\partial_T \partial_{\bar{T}} Z^{(1)} = \frac{2i}{S - \bar{S}} \left(\tilde{\mathcal{I}}_1^{A,\bar{A}} + \tilde{\mathcal{I}}_2^{A,\bar{A}} \right), \quad (3.3.2)$$

where $\tilde{\mathcal{I}}_1^{A,\bar{A}}$ and $\tilde{\mathcal{I}}_2^{A,\bar{A}}$ are contributions from the degenerate and non-degenerate orbits respectively, as computed in the previous section.

Similarly, using $\sum_a A^a A^a = -2BC$, the one-loop correction to the coefficient H_{BC} in Equation 3.1.2 (where again we perform a Weyl rescaling) satisfies,

$$\partial_T \partial_{\bar{T}} H_{BC}^{(1)} = \frac{-4i}{S - \bar{S}} \left(\tilde{\mathcal{I}}_1^{A,A} + \tilde{\mathcal{I}}_2^{A,A} \right). \quad (3.3.3)$$

An additional constraint for the Kähler potential that gives the above Kähler metric terms is of course that it is required to be invariant under modular transformations of the moduli, up to Kähler transformations. Taking all of this into

account, we find,

$$Z^{(1)} = \frac{-2c_1}{\pi(S - \bar{S})(T - \bar{T})(U - \bar{U})} \left\{ \left(\frac{E(U, 2)}{(T - \bar{T})} + \frac{\mathcal{P}(T)}{(U - \bar{U})} \right) \right\} \\ - \frac{4\pi^2 c_2}{(S - \bar{S})(T - \bar{T})(U - \bar{U})} \log \left[-e^{-2\gamma} \pi(T - \bar{T})(U - \bar{U}) |\eta(T)\eta(U)|^4 \right], \quad (3.3.4)$$

$$H_{BC}^{(1)} = \frac{-2c_1}{\pi(S - \bar{S})(T - \bar{T})(U - \bar{U})} \left\{ \left(\frac{E(U, 2)}{(T - \bar{T})} + \frac{\mathcal{P}(T)}{(U - \bar{U})} \right) \right\} \\ - \frac{4\pi^2 c_2}{(S - \bar{S})} \left\{ \frac{\pi^2}{36} + \left[2\partial_U \log \eta(U) + \frac{1}{(U - \bar{U})} \right] \left[2\partial_T \log \eta(T) + \frac{1}{(T - \bar{T})} \right] \right\}, \quad (3.3.5)$$

where

$$\mathcal{P}(T) = 2\pi^2 \sum_{m>0} m [\text{Li}_2(q_T^m) + \text{Li}_2(\bar{q}_T^m)] + \frac{\pi}{T_2} \sum_{m>0} [\text{Li}_3(q_T^m) + \text{Li}_3(\bar{q}_T^m)]. \quad (3.3.6)$$

The above expressions for $Z^{(1)}$ and $H_{BC}^{(1)}$ can also be shown to be consistent with the other two point amplitudes involving U and \bar{U} or T and \bar{T} .

3.4 Restoration of shift-symmetry

Let us now return to our goal, which is to compare the coefficients $Z^{(1)}$ and $H_{BC}^{(1)}$ in order to determine whether the shift-symmetry holds at one loop. Were this symmetry to be exact at this order, one would find equal $Z^{(1)}$ and $H_{BC}^{(1)}$. However, only the first lines of Equation 3.3.4 and Equation 3.3.5 are explicitly equal. Note also that at large T_2 these terms are actually sub-leading. Therefore further examination of the remaining terms is required to determine the extent

of the breaking of shift-symmetry. These terms can be expressed respectively as,

$$\begin{aligned} \tilde{Z} = & \frac{-4\pi^2 c_2}{(S - \bar{S})(T - \bar{T})(U - \bar{U})} \left\{ \log[-e^{-2\gamma} \pi (T - \bar{T})(U - \bar{U})] \right. \\ & + 2 \sum_{k>0} \left[\log(1 - q_U^k) + \log(1 - \bar{q}_U^k) \right] + 2 \sum_{k>0} \left[\log(1 - q_T^k) + \log(1 - \bar{q}_T^k) \right] \left. \right\} \\ & - \frac{4\pi^2 c_2}{(S - \bar{S})} \left\{ \frac{\pi}{12U_2} + \frac{\pi}{12T_2} \right\}, \end{aligned} \quad (3.4.1)$$

$$\begin{aligned} \tilde{H} = & \frac{-4\pi^2 c_2}{(S - \bar{S})} \left\{ \frac{2\pi^2}{3} \sum_{k>0} \left[\frac{kq_T^k}{1 - q_T^k} + \frac{kq_U^k}{1 - q_U^k} \right] - 16\pi^2 \sum_{k>0} \frac{kq_T^k}{1 - q_T^k} \sum_{m>0} \frac{mq_U^m}{1 - q_U^m} \right. \\ & + 2\pi \sum_{k>0} \left[\frac{1}{U_2} \frac{kq_T^k}{1 - q_T^k} + \frac{1}{T_2} \frac{kq_U^k}{1 - q_U^k} \right] - \frac{1}{4T_2 U_2} \left. \right\} - \frac{4\pi^2 c_2}{(S - \bar{S})} \left\{ \frac{\pi}{12U_2} + \frac{\pi}{12T_2} \right\}. \end{aligned} \quad (3.4.2)$$

Aside from the final terms appearing in each of the above expressions, \tilde{Z} and \tilde{H} are not equivalent in general, and so the shift-symmetry will not generically hold. Nevertheless, we are interested in the possibility that in the large U_2 limit the shift-symmetry is restored as discussed in the introduction. Any breaking of shift symmetry translates directly into shifts in the typical induced soft-terms of the form

$$\frac{\delta m^2}{m^2} = \frac{\text{Re}(\tilde{H} - \tilde{Z})}{Z^{(1)}}, \quad (3.4.3)$$

where m^2 is the mass-squared of the heavy Wilson line scalar. Note that in writing this expression we are using the fact that the *tree-level* masses of *all* the scalars are zero in these theories due to their no-scale structure. Therefore the expression above incorporates the leading one-loop contribution proportional to the gravitino mass $m_{3/2}$. We should also remark that additional contributions to masses come from other one-loop effects such as the Green-Schwarz mechanism, if there is one operating in the theory. Moreover what we are calculating here are stringy thresholds and there will be contributions from lighter modes such as stops in a complete model. Of course if one could construct a completely phenomenologically accurate broken MSSM within the string theory one would be

able to compute such effects within the string theory as well; so we are focussing on the violations of shift-symmetry that are certain to exist in the string thresholds of any theory of this type.

Let us now test our expectation that this ratio tends to zero in asymmetric compactification; as this implies $T_2 \gg 1$, the terms in the Kähler potential with any dependence on q_U^k are exponentially suppressed, and we can write,

$$\begin{aligned} \tilde{H} - \tilde{Z} = & -\frac{4\pi^2 c_2}{(S - \bar{S})} \left\{ \frac{2\pi^2}{3} \sum_{k>0} \frac{kq_U^k}{1 - q_U^k} + 2\pi \sum_{k>0} \frac{1}{T_2} \frac{kq_U^k}{1 - q_U^k} + \frac{\log[4\pi e^{-2\gamma} T_2 U_2]}{4T_2 U_2} \right. \\ & \left. + \frac{1}{T_2 U_2} \sum_{k>0} [\log(1 - q_U^k) + \log(1 - \bar{q}_U^k)] - \frac{1}{4T_2 U_2} \right\}, \end{aligned} \quad (3.4.4)$$

while for $Z^{(1)}$ we have,

$$\begin{aligned} Z^{(1)} = & -\frac{ic_1 E(U, 2)}{4\pi(S - \bar{S})T_2^2 U_2} - \frac{4\pi^2 c_2}{(S - \bar{S})} \left\{ \frac{\log[4\pi e^{-2\gamma} T_2 U_2]}{4T_2 U_2} + \frac{\pi}{12T_2} + \frac{\pi}{12U_2} \right. \\ & \left. + \frac{1}{T_2 U_2} \sum_{k>0} [\log(1 - q_U^k) + \log(1 - \bar{q}_U^k)] \right\}. \end{aligned} \quad (3.4.5)$$

In the limit $U_2 \gg 1$, recalling that we also have the condition $T_2 > U_2$, we find the dominant contribution to be

$$\frac{\delta m^2}{m^2} \sim \frac{3 \log[4\pi e^{-2\gamma} T_2 U_2]}{\pi(T_2 + U_2)}, \quad (3.4.6)$$

which clearly vanishes in the $T_2 > U_2 \rightarrow \infty$ limit as expected, with $1/(T_2 + U_2)$ being the small parameter. Conversely, when $T_2 \gg 1$ but $U_2 \ll 1$, we find

$$\frac{\delta m^2}{m^2} \sim \frac{4\pi U_2}{3} \sum_{k>0} \frac{kq_U^k}{1 - q_U^k}, \quad (3.4.7)$$

which grows as U_2 decreases and moreover it is not small.

We should point out that in taking the limits $T_2 \rightarrow \infty$ and $U_2 \rightarrow \infty$, one needs to be sure that a perturbative computation is still a sensible thing to do. These limits correspond to a large volume theory where the modified loop counting parameter remains small for sufficiently large $S_2 = \text{Im}(S)$, in which case a perturbative expansion may still be valid at all energies. One-loop threshold

corrections imply an upper bound on T_2 and U_2 [32]; indeed the loop expansion parameter (essentially the 't Hooft coupling) is order T_2/S_2 , implying that large volumes can be achieved with weak string coupling.

We conclude that ideas such as those presented in ref.[16–19] can be extremely effective in highly asymmetric configurations for the general reasons outlined in the Introduction. Indeed for the class of compactifications considered here, the heavy Higgs is already one-loop suppressed with respect to the gravitino mass (gaining a mass through RG running as usual in no-scale models), while the light Higgs is further parametrically suppressed by the asymmetry. A more model dependent question is of course if and how shift-symmetries are violated by the RG effects of the low energy theory, which may be computed in the effective field-theory as in ref.[16–19]. In a complete picture, such violations of shift-symmetry would arise from spontaneous breaking due to for example flavon fields, leading to light pseudo-Nambu-Goldstone modes, which may or may not mix with the Higgs. In principle the techniques presented could be applied to those more complete cases in an entirely stringy setting. Here we have seen that even if shift symmetries appear to be a strong feature of the classical field theory, asymmetric compactification is required to protect them in the threshold corrections as well.

It would of course be useful to consider these questions in more general settings such as constructions involving D-branes in type II, or smooth Calabi-Yaus. Whilst radiative violations of shift-symmetries in the former would almost certainly be calculable (as per [20]) if the backgrounds are sufficiently flat, the latter is notoriously difficult to treat perturbatively. One could hope to develop heuristic arguments along the lines of those in the introduction, and indeed there may be interesting overlaps with shift-symmetry restoration in certain limits of the type II systems in [33]. We should remark that shift-symmetries have also come to the fore because of their central role in schemes that try to explain the weak-Planck hierarchy by means of cosmological relaxation [34, 35], a subject which has recently received much attention [36–49]. Although these often feature axionic (i.e. compact) symmetries, non-compact shift-symmetries may be of more utility

given the need for trans-Planckian field excursions. Moreover in supersymmetric theories the two are in any case related by complexification of the Goldstone manifold. Therefore it may be of interest to revisit this question in the present context.

Chapter 4

The cosmological constant in non-SUSY strings at two loops and beyond

4.1 Introduction and conclusion

There has been interest recently in non-supersymmetric string theories, in which one might build the Standard Model (SM) directly. One particular object of focus has been the partial solution of the instability problems that generally arise in the absence of space-time supersymmetry (SUSY). In refs.[7, 50, 51] it was pointed out that a natural starting point for non-supersymmetric strings is a certain set of Scherk-Schwarz (SS) string models that have accidental Bose-Fermi degeneracy in their massless spectra. In these theories successive Kaluza-Klein (KK) levels are unable to contribute to the one-loop cosmological constant, which can only get contributions from heavy winding modes, string excitation modes and also from non-level matched states. As these modes are all short-range, they are unable to explore the whole compact volume. Consequently, even if the compactification scale is only moderately large, their contribution to the cosmological constant (and hence destabilising dilaton tadpoles) is parametrically exponentially suppressed. Such a cosmological constant, generated entirely by

heavy modes, allows novel separations of finite UV and IR contributions to the potential [52].

An open question is what happens at two-loops and beyond in such theories. Does the exponential suppression continue? Field theory intuition says that generic two-loop contributions will start to make their appearance, but it is conceivable that some kind of string “miracle” appears to save the day, or that a further subset of one-loop suppressed theories may have two-loop suppression in the cosmological constant as well. This chapter shows by explicit calculation that (while we cannot rule out the former) the latter is highly likely. We derive two criteria that define a sub-class of theories which continue to enjoy exponential suppression at two-loops. Like the one-loop case, this suppression is simply an accidental consequence of their particle content.

Our programme, and this entire approach, is reminiscent of the field theory ideas of refs.[53–56] which attempt to achieve *naturalness without supersymmetry*, by essentially extending the Veltman condition of ref.[57] to all orders. Indeed, it is a remarkable fact that, thanks to the theorem of Kutasov and Seiberg [58], non-supersymmetric string theories with $D = 4$ whose cosmological constant vanishes at one-loop must also satisfy the “field independent” Veltman condition, namely $\text{Str}(M^2) = 0$ [59, 60]. Hence although the object of study here is the cosmological constant, not the mass of some putative Higgs, there is a direct link. However the string case goes even further than the field theory one: there are no freely adjustable couplings, since couplings are all either zero or one (or themselves exponentially suppressed by the volume), so there is absolutely no fine-tuning involved. Theories either have the correct massless particle content or they do not.

At the one-loop level, because of this connection to the Veltman condition, any model with vanishing cosmological constant can be thought of as a stringy UV completion of the scenario outlined in ref.[56]. Although we stress that the operator being considered here is the cosmological constant, the exact same procedure could be carried out for the Higgs mass-squared itself. This is discussed

in more detail in ref.[61]. In the models of ref.[7], this is achieved because a Scherk-Schwarz deformation preserves the Bose-Fermi degeneracy of the massless modes in all of their KK levels as well. In the logarithmically running low energy theory, one then assumes that the relevant scale at which such a relation should be applied is the compactification scale, above which the theory becomes extra dimensional. An important difference though is the motivation for imposing the condition at that scale which has nothing to do with SUSY being restored there, but rather the one-loop cosmological constant vanishing¹.

At the *two-loop* level, we will find as mentioned two rather different looking criteria for vanishing cosmological constant. The criterion for the vanishing of the entirely untwisted contributions (that is diagrams whose propagators contain only the descendants of broken $\mathcal{N} = 2$ supermultiplets) is a complicated combination of parameters (numbers of gauge bosons, gauginos, hypermultiplets and so forth) that essentially counts the two-loop effective field theory divergences. As we will demonstrate, this parameter is most easily extracted from the constant term in the “ q -expansion” of the two-loop string partition function. By contrast diagrams that contain twisted loops (that is loops of twisted states that still appear in complete $\mathcal{N} = 1$ chiral supermultiplets) can vanish due to the cancellation of combinations of “field dependent” Veltman conditions. Such diagrams have a different dependence on the volume modulus from the entirely untwisted ones, so to avoid fine-tuning one has to impose a second independent criterion for the twisted states, of the form $\sum_U (-1)^{F_U} \text{Tr} |Y_{UTT}|^2 = 0$ where U stands for generic untwisted fields in the theory, and the trace is over the pairs of twisted states to which they couple, with tree-level coupling Y_{UTT} . This criterion is quite Veltman-like, but note that it is the *sum* over the Veltman conditions of all the twisted states that appears; we do not need to apply them individually. Furthermore the couplings are degenerate, so again the vanishing of this quantity is a question of

¹Note that we cannot even say the theory becomes *approximately* supersymmetric at the scale $1/R$ because of the arguments presented in ref.[7]: whilst at order $1/R$ the KK spectrum is indeed supersymmetric, the other stringy modes, in particular winding modes, manifestly break SUSY.

particle content.

An important aspect to bear in mind is that one requires an absence of gravitationally coupled products of one-loop divergences in order to produce the above criteria. This contribution would normally come from the so-called separating degeneration limit of the two-loop partition function, which we will discuss in some detail. Such terms are absent only if one has chosen a theory that already satisfies the criterion for the *one-loop* cosmological constant to vanish, namely massless Bose-Fermi degeneracy, $N_b^{(0)} - N_f^{(0)} = 0$. Indeed, more generally one can see that at each order, a sensible criterion for continued suppression can only be achieved when the criteria for all the orders below are satisfied.

The work contained in this chapter naturally follows on from previous research into non-supersymmetric strings. The idea of Scherk-Schwarz SUSY breaking [62] was first adapted to the string setting in refs.[63–66], which introduced Coordinate Dependent Compactification (CDC). Subsequently, there has been extensive research into the one-loop cosmological constant [50, 51, 58–60, 67–87], their finiteness [59, 60, 69–71, 88], how they relate to strong/weak coupling duality symmetries [89–94], and ideas relating to the string landscape [95, 96]. The mechanism of CDC has been further developed in refs.[97–101] while phenomenological ideas have been explored further in refs.[74, 75, 94, 102–111]. Additionally, solutions to the large volume “decompactification problem” have been discussed in[112–115], while numerous other configurations of non-supersymmetric string models have been discussed in refs.[116–132], which have included the study of relations between scales in different schemes [133–139].

The results we have found are a natural extension of this work, which leads one to speculate on the existence of three-loop and beyond cancellations, and whether there might be a universal condition for string theories that, like the one conjectured for field theory in ref.[53], ensures cancellation to all orders. Conversely, it raises the possibility that imposing the requirement of continued exponential suppression to ever higher order could give interesting predictions for the particle content of the theory.

4.2 Two-loop amplitudes

4.2.1 The set-up in the ϑ -function formalism

Let us begin by collecting and digesting the necessary results for the calculation of the two-loop cosmological constant. Multiloop string calculations of the cosmological constant have been considered in the past in refs. [50, 51, 86, 140–150]. However, care is required from the outset as there are possible pitfalls. In particular, one of the major difficulties in calculating string amplitudes beyond one-loop proved to be the integrating out of the supermoduli. If done incorrectly, computations of this type typically give ambiguous results that depend on the choice of gauge. For example, attempts were made in the past to determine the value of the two-loop vacuum amplitude for the non-supersymmetric models presented in refs.[50, 51] (the so-called KKS models). The initial claim was that the cosmological constant is vanishing, but contradictory evidence was presented in ref.[86]. In fact both of these results suffered from the aforementioned issue of gauge dependence. A correct gauge-fixing procedure was later introduced in the work of refs.[151–154], and the computation was re-done in ref.[155] with the conclusion that the two-loop contribution is indeed non-vanishing for the KKS models. It is these later papers that form the basis of our analysis.

For the type of non-supersymmetric model described in ref.[7], one does not actually expect the two-loop contribution to the cosmological constant to be identically zero. As described in the Introduction, the best one can achieve at one-loop is for it to be exponentially suppressed if the massless spectrum contains an equal number of bosons and fermions. Therefore we seek a similar suppression at higher loop order.

Note that as the main source of the cosmological constant (a.k.a. Casimir energy) in large volume Scherk-Schwarz compactifications is the massless spectrum, one might think it is preferable to approach the entire problem from the perspective of the effective field theory. However at two loops, it is not always obvious how the string computation factorises onto the field theory diagrams.

In addition one would have to perform an analysis in the effective softly broken supergravity, and there are certain purely string contributions, in particular the separating degeneration limit (of which more later), that one has to check. These issues are exacerbated by the fact that the string models typically have a large rank making it tedious to count states, and by the fact that one would in any case have to determine all the tree-level couplings of the effective field theory. As we shall see, it is by contrast far easier to simply extract the coefficient of the relevant (constant) term from the q -expansion of the two-loop partition function.

The structure of two-loop superstring amplitudes is built upon the representation of the worldsheet by a super Riemann surface of genus two. Let us start with a brief outline of the essential properties of such surfaces, and as a warm-up exercise then perform the computation of the two-loop cosmological constant in an entirely supersymmetric theory.

Consider a super Riemann surface of genus g with a canonical homology basis of A_I and B_I cycles as shown in Figure 4.1. The period matrix Ω_{IJ} is given by holomorphic abelian 1-forms w_I dual to the A_I -cycles such that

$$\oint_{A_I} \omega_J = \delta_{IJ}, \quad \oint_{B_I} \omega_J = \Omega_{IJ}. \quad (4.2.1)$$

In addition to the period matrix there is the *super* period matrix, $\hat{\Omega}_{IJ}$, which can be defined in a similar way, by integrating superholomorphic 1/2 forms over the A_I and B_I cycles.

The supermoduli space \mathfrak{M}_g of a genus g super Riemann surface contains $3g - 3$ even moduli and $2g - 2$ odd moduli for $g \geq 2$. Specialising to the case where

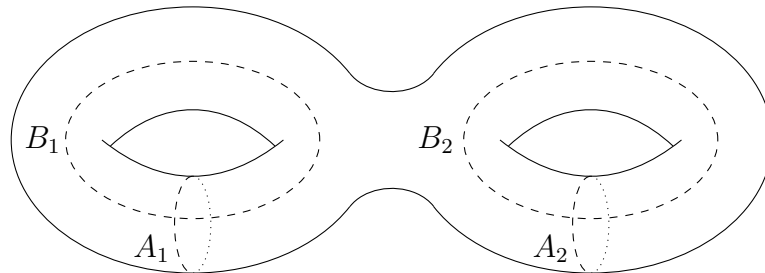

Figure 4.1: Canonical homology basis for genus 2.

$g = 2$, the super period matrix gives a natural projection of the supermoduli space of a super Riemann surface onto the moduli space of a Riemann surface, and its 3 independent complex entries provide complex coordinates for the moduli space of even moduli, \mathcal{M}_2 . The super period matrix can be expressed in a simple way in terms of the period matrix and, following the procedure of refs.[151–154], one can work in the so-called split gauge, which has the main advantage that the period matrix and super period matrix are equivalent, and one can simply use Ω_{IJ} to denote both. It can be parametrised by

$$\Omega = \begin{pmatrix} \tau_{11} & \tau_{12} \\ \tau_{12} & \tau_{22} \end{pmatrix}, \quad (4.2.2)$$

where τ_{11} , τ_{12} and τ_{22} are the complex variables corresponding to the three moduli (i.e. playing the same role as τ in the one-loop diagrams). To make the discussion widely accessible, we present the result (which derives from refs.[151–154] after some work and carefully accounting for the measure) in terms of two-loop ϑ -functions, the most natural extension of the standard one-loop formalism.

For a genus 2 surface there are 16 independent spin structures, labelled by half-integer characteristics²

$$\kappa = \begin{bmatrix} \kappa' \\ \kappa'' \end{bmatrix}, \quad \kappa', \kappa'' \in \left(0, \frac{1}{2}\right)^2, \quad (4.2.3)$$

where κ' is a 2-vector of spin structures on the A_I -cycles, and κ'' is a 2-vector of spin-structures on the B_I -cycles.

The ϑ -functions with characteristic v are defined by

$$\vartheta[\kappa](v, \Omega) \equiv \sum_{n \in \mathbb{Z}^2} \exp\{i\pi(n + \kappa')^t \Omega (n + \kappa') + 2\pi i(n + \kappa')^t (v + \kappa'')\}. \quad (4.2.4)$$

A given spin structure is said to be *even or odd* depending on whether $4\kappa' \cdot \kappa''$ is even or odd. For vanishing characteristics, $v = 0$, all of the 6 *odd* spin-structure

²Note that in our conventions, the spin structures are given as the transpose of those appearing in refs.[151–154]

ϑ -functions are identically zero (much like ϑ_{11} in the one-loop case), so that

$$\vartheta\left[\begin{smallmatrix} \frac{1}{2} & 0 \\ \frac{1}{2} & 0 \end{smallmatrix}\right] = \vartheta\left[\begin{smallmatrix} 0 & \frac{1}{2} \\ 0 & \frac{1}{2} \end{smallmatrix}\right] = \vartheta\left[\begin{smallmatrix} \frac{1}{2} & \frac{1}{2} \\ \frac{1}{2} & 0 \end{smallmatrix}\right] = \vartheta\left[\begin{smallmatrix} \frac{1}{2} & \frac{1}{2} \\ 0 & \frac{1}{2} \end{smallmatrix}\right] = \vartheta\left[\begin{smallmatrix} \frac{1}{2} & 0 \\ \frac{1}{2} & \frac{1}{2} \end{smallmatrix}\right] = \vartheta\left[\begin{smallmatrix} 0 & \frac{1}{2} \\ \frac{1}{2} & \frac{1}{2} \end{smallmatrix}\right] \stackrel{v \rightarrow 0}{\equiv} 0. \quad (4.2.5)$$

The even spin structures will be denoted generically with a δ , and the even ones with a ν : for example even ϑ -functions will be written as $\vartheta[\delta]$.

After integrating over the supermoduli, enforcing the GSO projection and summing over spin structures, the cosmological constant for the *supersymmetric* heterotic string can be written [151–154]

$$\Lambda_{2-loop} = \int_{\mathcal{F}_2} \frac{d^3\Omega_{IJ}}{(\det \operatorname{Im} \Omega)^5} \frac{\Upsilon_8(\Omega) \overline{\Psi_8(\Omega)}}{|16\pi^6 \Psi_{10}(\Omega)|^2}, \quad (4.2.6)$$

where $d^3\Omega_{IJ} = d^2\tau_{11}d^2\tau_{12}d^2\tau_{22}$, and the integration is over the fundamental domain of the moduli, \mathcal{F}_2 , typically taken to be [156–158]

1. $-\frac{1}{2} < \operatorname{Re}(\Omega_{11}), \operatorname{Re}(\Omega_{12}), \operatorname{Re}(\Omega_{22}) \leq \frac{1}{2}$,
2. $0 < 2 \operatorname{Im}(\Omega_{12}) \leq \operatorname{Im}(\Omega_{11}) \leq \operatorname{Im}(\Omega_{22})$,
3. $|\det(C\Omega + D)| \geq 1 \quad \forall \begin{pmatrix} A & B \\ C & D \end{pmatrix} \in Sp(4, \mathbb{Z})$.

The modular forms appearing in Equation 4.2.6 are defined as follows. First it is useful to define

$$\Xi_6[\delta](\Omega) \equiv \sum_{1 \leq i < j \leq 3} \langle \nu_i | \nu_j \rangle \prod_{k=4,5,6} \vartheta[\nu_i + \nu_j + \nu_k]^4(0, \Omega). \quad (4.2.7)$$

This expression uses the fact that any even spin structure can be written as the sum of three odd spin structures, $\delta = \nu_1 + \nu_2 + \nu_3$; in the sum, $\nu_{4,5,6}$ are the remaining three odd spin structures, and

$$\langle \kappa | \rho \rangle \equiv \exp\{4\pi i(\kappa' \cdot \rho'' - \rho' \cdot \kappa'')\}. \quad (4.2.8)$$

In term of Ξ_6 we then have

$$\Upsilon_8(\Omega) = \sum_{\delta \text{ even}} \vartheta[\delta]^4(\Omega) \Xi_6[\delta](\Omega),$$

$$\Psi_{10}(\Omega) = \prod_{\delta \text{ even}} \vartheta[\delta]^2(0, \Omega), \quad (4.2.9)$$

where the product is obviously over even spin structures only. In the end the two-loop cosmological constant in a SUSY theory is of course zero, as it should be; this is due to the genus two version of the abstruse identity, namely $\Upsilon_8 = 0$.

4.2.2 The Scherk-Schwarz cosmological constant

Adapting the technology of the previous section, one can now start to build up the two-loop cosmological constant for the *non*-supersymmetric theories of ref.[7]. These theories are constructed by taking a 6D theory in the free fermionic formulation and compactifying down to 4D on a $\mathbb{T}_2/\mathbb{Z}_2$ orbifold, breaking spacetime supersymmetry through a coordinate dependence in the compactification (CDC). This is the equivalent of the Scherk-Schwarz mechanism in string theory. Sectors that are twisted under the final orbifolding remain supersymmetric under the deformation, and so their spectrum is unchanged. (Whenever we refer to “twisted” or “untwisted” this will always mean with respect to the final orbifolding.) At genus two there can be a twist associated with each loop, but the focus will mainly be on the totally untwisted sectors since twisted states are involved in a very restricted set of diagrams due to their remaining supersymmetric structure.

It is worth elaborating on this last particular aspect before we start the calculation of the totally untwisted diagrams in earnest. One can proceed by constructing an extension of the argument of refs.[7, 65]. At one-loop the partition function of the $\mathcal{N} = 0$ deformed theory (whose orbifold action we shall denote by g) is decomposed as

$$\mathcal{Z}(\mathbf{e}) = \frac{1}{2} \left(\mathcal{Z}_0^0(\mathbf{e}) - \mathcal{Z}_0^0(\mathbf{0}) \right) \quad (4.2.10)$$

$$+ \frac{1}{2} \left(\mathcal{Z}_0^0(\mathbf{0}) + \mathcal{Z}_g^g + \mathcal{Z}_g^0 + \mathcal{Z}_g^g \right), \quad (4.2.11)$$

where the indices represent the orbifold action on the A and B cycle. The Scherk-Schwarz phases on the world-sheet degrees of freedom are denoted by a vector \mathbf{e} . The only dependence on them is in the first totally untwisted term. The second

term is (up to the factor of 1/2) the partition function of the non-orbifolded and non-deformed $\mathcal{N} = 2$ theory, while the second line is the partition function of an entirely undeformed $\mathcal{N} = 1$ theory; both are zero, and hence only the first term can give a non-zero contribution to the cosmological constant. (So for example any $\mathcal{N} = 2 \xrightarrow{\mathfrak{e}} \mathcal{N} = 0$ un-orbifolded theory with Bose-Fermi degeneracy implies the existence of a chiral orbifolded $\mathcal{N} = 1 \xrightarrow{\mathfrak{e}} \mathcal{N} = 0$ theory that also has Bose-Fermi degeneracy.)

Continuing to two loops, a similar decomposition would look like

$$\begin{aligned}
4\mathcal{Z}(\mathbf{e}) = & \mathcal{Z}_{00}^{00}(\mathbf{e}) - \mathcal{Z}_{00}^{00}(\mathbf{0}) + \mathcal{Z}_{00}^{0g}(\mathbf{e}) - \mathcal{Z}_{00}^{0g}(\mathbf{0}) + \dots \\
& + \left(\mathcal{Z}_{00}^{00}(\mathbf{0}) + \mathcal{Z}_{00}^{0g}(\mathbf{0}) + \mathcal{Z}_{0g}^{00}(\mathbf{0}) + \mathcal{Z}_{00}^{g0}(\mathbf{0}) + \mathcal{Z}_{0g}^{00}(\mathbf{0}) + \dots \right. \\
& \left. + \mathcal{Z}_{00}^{gg} + \mathcal{Z}_{0g}^{g0} + \dots + \mathcal{Z}_{gg}^{gg} \right), \tag{4.2.12}
\end{aligned}$$

where now of course there are two cycles. The bracket is the undeformed $\mathcal{N} = 1$ theory and must vanish by supersymmetry, and the first term is the partition function for the entirely un-orbifolded theory, representing contributions containing the untwisted fields only. Clearly the one loop argument would go through as before, were it not for the additional \mathbf{e} -dependent terms on the first line, which represent diagrams that have twisting on one pair of A_I, B_I cycles, with the other pair of A_I, B_I cycles remaining entirely untwisted. Such diagrams will be referred to as “mixed” diagrams. What remains is therefore to determine the contributions of the mixed diagrams at leading order, and the contribution from the entirely untwisted first term, $\mathcal{Z}_{00}^{00}(\mathbf{e})$. It is these two different kinds of contribution that lead to the two criteria mentioned in the Introduction.

The former will be dealt with explicitly later, but for the moment let us now turn to the calculation for the entirely untwisted contribution which is (up to a factor) the cosmological constant of the un-orbifolded theory. To define the sums over spin structures, the CDC and vector notation is the standard one, summarised in ref.[7]. In particular dot-products are the usual Lorentzian ones, while a separate sum over basis vectors \mathbf{V}_a is understood; thus explicitly the collection of spin-structures in a particular sector are $\alpha^I \mathbf{V} \equiv \alpha_a^I \mathbf{V}_a$ and $\beta^I \mathbf{V} \equiv$

$\beta_a^I \mathbf{V}_a$, with a labelling the basis vectors and, recall, $I = 1, 2$ labelling the A_I and B_I cycles. The right- and left-moving fermions have spin-structures denoted

$$\mathbf{S}'_R = \begin{bmatrix} (\alpha \mathbf{V})' \\ (\beta \mathbf{V})' \end{bmatrix}_R, \quad \mathbf{S}'_L = \begin{bmatrix} (\alpha \mathbf{V})' \\ (\beta \mathbf{V})' \end{bmatrix}_L.$$

The primes represent the shift due to the CDC deformation, that is

$$\begin{aligned} (\alpha^I \mathbf{V})' &= \alpha^I \mathbf{V} - n^I \mathbf{e} \\ (-\beta^I \mathbf{V})' &= -\beta^I \mathbf{V} + \ell^I \mathbf{e}, \end{aligned} \quad (4.2.13)$$

where $n^I = n^{1I} + n^{2I}$, $\ell^I = \ell_1^I + \ell_2^I$ and n^{iI} are the winding numbers and ℓ_i^I are the *dual*-KK numbers in the Poisson resummed theory. In the present context, there are 16 transverse right-moving real fermions and 40 transverse left-moving real fermions on the heterotic string (so that $\mathbf{S}'_{R/L}$ are vectors containing 16 and 40 different spin structures respectively).

After a little work, the techniques of ref.[151–154] yield the two-loop cosmological constant expressed purely in the ϑ -function formalism:

$$\Lambda_{2-loop} = \int_{\mathcal{F}_2} \frac{d^3 \Omega_{IJ}}{(\det \text{Im } \Omega)^3} \sum_{\{\alpha^a, \beta^a\}} \frac{\Gamma_{2,2}^{(2)}}{|\Psi_{10}|^2} \tilde{C}' \begin{bmatrix} \alpha \\ \beta \end{bmatrix} \Xi_6 \begin{bmatrix} \alpha^1 s & \alpha^2 s \\ \beta^1 s & \beta^2 s \end{bmatrix} \prod_{i=1}^{16} \vartheta[S'_{Ri}]^{1/2} \prod_{j=1}^{40} \bar{\vartheta}[S'_{Lj}]^{1/2}, \quad (4.2.14)$$

where $d^3 \Omega_{IJ} = d^2 \tau_{11} d^2 \tau_{12} d^2 \tau_{22}$ and where ‘ s ’ denotes the non-compact space-time entries of the spin-structure vectors.

Let us describe the factors in detail. In addition to the self-evident fermion factors, the compactification from 6D to 4D has introduced an extra factor of the two-loop Narain partition function for the two compact bosonic degrees of freedom, $\Gamma_{2,2}^{(2)}$. In its original *non*-Scherk-Schwarz and *un*-Poisson resummed format it would look like

$$\Gamma_{2,2}^{(2)}(\Omega; G, B) = \det \text{Im } \Omega \sum_{(m_i^I, n^{iI})} e^{-\pi \mathcal{L}^{IJ} \text{Im}(\Omega_{IJ}) + 2\pi i m_i^I n^{iJ} \text{Re}(\Omega_{IJ})}, \quad (4.2.15)$$

where

$$\mathcal{L}^{IJ} = (m_i^I + B_{ik} n^{Ik}) G^{ij} (m_j^J + B_{jl} n^{lJ}) + n^{iI} G_{ij} n^{jJ}, \quad (4.2.16)$$

and where G_{ij} and B_{ij} are the usual metric and antisymmetric tensor respectively.

After introducing the CDC shift and performing a Poisson resummation on all of the m 's, it takes the form

$$\Gamma_{2,2}^{(2)} = T_2^2 \sum_{\ell_i^I, n_i^I} \exp \left\{ -\frac{\pi T_2}{U_2 \det \text{Im } \Omega} \left[|M_1^1 + M_2^1 U|^2 \text{Im } \tau_{22} + |M_1^2 + M_2^2 U|^2 \text{Im } \tau_{11} \right. \right. \\ \left. \left. - \left((M_1^1 + M_2^1 U)(M_1^2 + M_2^2 U)^* + c.c. \right) \text{Im } \tau_{12} \right] \right\} \times e^{-2\pi i T (n_1^1 \ell_2^1 + n_1^2 \ell_2^2 - n_2^1 \ell_1^1 - n_2^2 \ell_1^2)} \quad (4.2.17)$$

where

$$\begin{aligned} M_1^1 &= \ell_1^1 - n_1^1 \tau_{11} - n_1^2 \tau_{12}, \\ M_1^2 &= \ell_1^2 - n_1^2 \tau_{22} - n_1^1 \tau_{12}, \\ M_2^1 &= \ell_2^1 - n_2^1 \tau_{11} - n_2^2 \tau_{12}, \\ M_2^2 &= \ell_2^2 - n_2^2 \tau_{22} - n_2^1 \tau_{12}. \end{aligned} \quad (4.2.18)$$

We should point out that in the above equations and in what follows, we have lowered the 'i' index on the winding numbers purely to simplify notation; they have *not* been lowered through the use of the metric G_{ij} . A word of warning is also required concerning the definition of the $\{\alpha^a, \beta^a\}$ summation in Equation 4.2.14: the partition function $\Gamma_{2,2}^{(2)}$ is of course a function of ℓ_i^I, n_i^I , but now so are the \mathbf{S}'_L and \mathbf{S}'_R due to the CDC induced shift. Therefore one cannot *really* factor the summations as we appear to do above: everything to the right of $\Gamma_{2,2}^{(2)}$ is to be correctly included in the sum over ℓ_i^I, n_i^I . However the case of ultimate interest is when the radii are moderately large, since as described in the Introduction we wish to determine the presence or otherwise of unsuppressed SS contributions to the vacuum energy. These can only correspond to $n^I = 0 \pmod{2}$ as is evident from Equation 4.2.17, while we require at least one of the $\ell^{I=1,2}$ to be equal to $1 \pmod{2}$ to avoid cancellation by supersymmetry. The Poisson resummation could have been done for different choices of the ℓ^I separately but it would amount to the same result. The result is leading terms that carry the usual volume dependence but are otherwise not suppressed. Conversely the sub-leading terms coming from the non-zero n^I modes would involve a simple generalisation of the saddle-point approximation used for the one-loop case in ref.[7] leading inevitably

to exponential suppression.

The final ingredients in Equation 4.2.14 are the GSO projection phases, $\tilde{C}\left[\begin{smallmatrix} \alpha \\ \beta \end{smallmatrix}\right]$. These can be deduced from the fact that two-loop partition functions factorise onto products of two one-loop partition functions in a certain limit of moduli space, at which point the GSO coefficients must factorise as well [85, 159]. Since the GSO coefficients are completely moduli independent, this factorization must hold everywhere. They can therefore be written as a product of the known genus one coefficients

$$\tilde{C}\left[\begin{smallmatrix} \alpha \\ \beta \end{smallmatrix}\right] = \tilde{C}\left[\begin{smallmatrix} \alpha^1 \\ \beta^1 \end{smallmatrix}\right] \tilde{C}\left[\begin{smallmatrix} \alpha^2 \\ \beta^2 \end{smallmatrix}\right]. \quad (4.2.19)$$

As described in ref.[160], most generally these are functions of the structure constants k_{ab} , k_{eb} , k_{ae} and k_{ee} , that take the following form

$$\tilde{C}\left[\begin{smallmatrix} \alpha^I \\ \beta^I \end{smallmatrix}\right] = \exp\left[2\pi i\left(\ell^I k_{ee} n^I - \ell^I k_{eb} \alpha_b^I - \beta_a^I k_{ae} n^I\right)\right] \exp\left[2\pi i\left(\alpha_a^I s_a + \beta_a^I s_a + \beta_a^I k_{ab} \alpha_b^I\right)\right], \quad (4.2.20)$$

with the vector \mathbf{e} assuming a projective role, completely analogous to that of the other basis vectors. For the canonical assignment of structure constants for the CDC vector \mathbf{e} , there is no sector dependence in the phases, that is

$$\tilde{C}\left[\begin{smallmatrix} \alpha^I \\ \beta^I \end{smallmatrix}\right] = \exp\left[2\pi i\left(\frac{1}{2}\ell^I \mathbf{e}^2 n^I - \beta^I \mathbf{V} \cdot \mathbf{e} n^I\right)\right] \exp\left[2\pi i\left(\alpha_a^I s_a + \beta_a^I s_a + \beta_a^I k_{ab} \alpha_b^I\right)\right]. \quad (4.2.21)$$

However, note that in Equation 4.2.14 we actually have $\tilde{C}'\left[\begin{smallmatrix} \alpha \\ \beta \end{smallmatrix}\right]$ rather than $\tilde{C}\left[\begin{smallmatrix} \alpha \\ \beta \end{smallmatrix}\right]$. This primed definition does not include the factors of $\exp[2\pi i(\alpha_a^I s_a + \beta_a^I s_a)]$ appearing in the above equations, which are effectively contained within Ξ_6 instead.

Equation 4.2.14 is the ‘‘master equation’’ that provides our first criterion. It is straightforward to check that it has the correct modular properties under $Sp(4, \mathbb{Z})$ by considering the transformations given in Equation B.5. As we are about to see, one can also use it to determine the leading contribution to the cosmological constant by deduce the q -expansions, by inserting the explicit expressions for the two loop ϑ -functions, in Appendix B. Writing the cosmological constant as

$$\Lambda_{2-loop} = \int_{\mathcal{F}_2} \frac{d^3 \Omega_{IJ}}{(\det \text{Im } \Omega)^3} \aleph, \quad (4.2.22)$$

the criterion for vanishing untwisted contribution to the two-loop cosmological constant is then that the constant term in the q -expansion of

$$\aleph = \sum_{\{\alpha^a, \beta^a\}} \frac{\Gamma_{2,2}^{(2)}}{|\Psi_{10}|^2} \tilde{C}' \left[\begin{matrix} \alpha \\ \beta \end{matrix} \right] \Xi_6 \left[\begin{matrix} \alpha^1 s & \alpha^2 s \\ \beta^1 s & \beta^2 s \end{matrix} \right] \prod_{i=1}^{16} \vartheta[S'_{Ri}]^{1/2} \prod_{j=1}^{40} \bar{\vartheta}[S'_{Lj}]^{1/2}, \quad (4.2.23)$$

vanishes. Note that \aleph is a product of the measure and the partition function.

4.2.3 The q -expansion of \aleph

Let us proceed to examine the q -expansions for the cosmological constant in certain limits, in particular the large radius limit. The general form of the integrand in the two-loop cosmological constant is

$$\aleph = \Gamma_{2,2}^{(2)} \sum_{\mathbf{a}, \mathbf{b} \in \mathbb{Z}^3} C_{\mathbf{ab}} q_1^{a_1} q_2^{a_2} q_3^{a_3} \bar{q}_1^{b_1} \bar{q}_2^{b_2} \bar{q}_3^{b_3}, \quad (4.2.24)$$

where $a_i \geq -1/2$ and $b_i \geq -1$. It is useful to define variables $Y_{I=1..3}$ such that $\tau_{11} \equiv Y_1 + Y_2$, $\tau_{12} \equiv Y_2$, $\tau_{22} \equiv Y_2 + Y_3$ with $q_I = \exp\{2\pi i Y_I\}$. Letting $L_I = \text{Im}(Y_I)$ so that

$$\text{Im } \Omega = \begin{pmatrix} L_1 + L_2 & L_2 \\ L_2 & L_2 + L_3 \end{pmatrix}, \quad (4.2.25)$$

the variables L_1, L_2, L_3 can be interpreted as Schwinger time parameters for the three propagators of the two-loop sunset Feynman diagram shown in Figure 4.2. With this parametrization, $\det \text{Im}(\Omega) = L_1 L_2 + L_2 L_3 + L_1 L_3$, and the fundamental domain \mathcal{F}_2 restricts the variables so that $0 < L_2 \leq L_1 \leq L_3$.

By parameterising the period matrix in this way, the q_I -expansion of \aleph is symmetric with respect to the three q_I . It can be relatively straightforwardly evaluated. The q -expansion of Ψ_{10}^{-1} is given by

$$\frac{2^{12}}{\Psi_{10}} = \frac{1}{q_1 q_2 q_3} + 2 \sum_{I < J} \frac{1}{q_I q_J} + 24 \sum_I \frac{1}{q_I} + \mathcal{O}(q_i). \quad (4.2.26)$$

The rest of \aleph is model dependent and can be determined using the q_I -expansions of the ϑ -functions in Appendix B.

As an example of the whole procedure we will consider an $SO(10)$ model

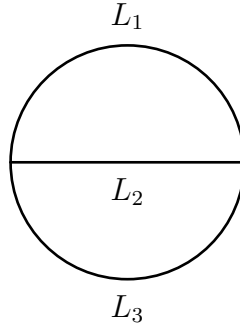

Figure 4.2: Generic sunset diagram for the two-point function.

that has massless Bose-Fermi degeneracy, and hence exponentially suppressed cosmological constant at one-loop. The model is presented in Appendix C, where it is shown explicitly that in the SUSY theory (i.e. the theory *without* any CDC deformation) the two-loop cosmological constant vanishes. It is also shown there that the one-loop cosmological constant in the broken theory is exponentially suppressed because there is Bose-Fermi degeneracy at the massless level, and hence the constant term in the *one*-loop partition function is absent.

Recall that non-vanishing two-loop contribution to the cosmological constant comes from sectors in which at least one of ℓ^1 and ℓ^2 is equal to 1 mod (2). For example, if $\ell^1 = \ell^2 = 1$, the q -expansion of \aleph in the full non-SUSY $SO(10)$ theory is found to be

$$\begin{aligned} \aleph &\propto \frac{1}{|\Psi_{10}|^2} (q_1 q_2 q_3 + \dots) \left(1 + \frac{1}{2} \bar{q}_1 \bar{q}_2 - \frac{33}{2} \bar{q}_1 \bar{q}_3 + \frac{1}{2} \bar{q}_2 \bar{q}_3 - 116 \bar{q}_1 \bar{q}_2 \bar{q}_3 + \dots \right) \\ &= \frac{1}{\bar{q}_1 \bar{q}_2 \bar{q}_3} + \frac{2}{\bar{q}_1 \bar{q}_2} + \frac{2}{\bar{q}_1 \bar{q}_3} + \frac{2}{\bar{q}_2 \bar{q}_3} + \frac{49}{2\bar{q}_1} + \frac{15}{2\bar{q}_2} + \frac{49}{2\bar{q}_3} - 147 + \mathcal{O}(q_I \bar{q}_J). \end{aligned} \tag{4.2.27}$$

The terms with $\ell^1 = 1$ and $\ell^2 = 0$, and with $\ell^1 = 0$ and $\ell^2 = 1$ have the coefficients of $1/\bar{q}_i$ permuted but are otherwise identical. In particular the constant term is the same. In total then, we find a non-vanishing constant piece, and conclude that this particular model gets a generic (i.e. not exponentially suppressed) contribution to the cosmological constant starting at two-loops.

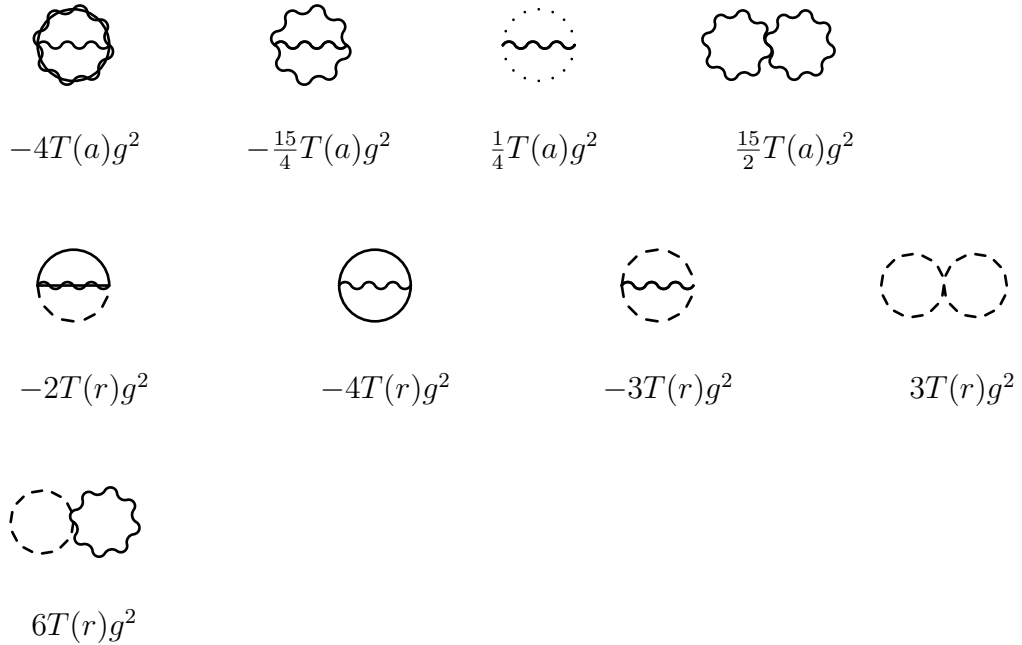

Figure 4.3: The Feynman diagrams for the two-loop cosmological constant in the effective $\mathcal{N} = 2$ field theory of the untwisted sector with dashed lines indicating scalar components of hypermultiplets, solid lines fermionic components. Likewise “photon” lines represent the bosonic component of the gauge supermultiplet (i.e. vector plus scalar adjoint), while the gaugino lines represent the $\mathcal{N} = 2$ gauginos. Leading order corrections (i.e. not exponentially suppressed) contributions are proportional to the sum over all these coefficients in the entire theory. In a supersymmetric theory the contributions vanish line by line as they should. In a Scherk-Schwarz theory, only those diagrams with *all masses unshifted* count (twice) towards the cosmological constant. Cancellation in a non-supersymmetric theory can be achieved by choosing field content.

4.2.4 Field theory factorization: identifying leading contributions

Note that the constant piece in \aleph includes various field theoretical contributions, not only the ones corresponding to the sunset topology. For reference the contributions in the field theory are displayed in Figure 4.3 in the parent $\mathcal{N} = 2$ formalism. They can in principle be computed in the 6D field theory following ref.[161]. Given the complexity of the theories involved, and the fact that one would have to determine the spectrum *and* all the effective couplings, this would be an extremely arduous task, and it is actually much easier to simply determine

the two-loop partition function directly as above. Nevertheless it is instructive to see how the expression of Equation 4.2.27 does indeed give the corresponding field theory contributions in the various degeneration limits.

First note that for sufficiently large compactification volume the non-zero *winding* mode contributions are extremely exponentially suppressed compared to those with $n_i^I = 0$. In addition the supersymmetric minimum for the CDC deformations is around $U_1 = 1$ as discussed in ref.[52]. Expanding around this point and using Equation 4.2.17, the dominant contributions to the cosmological constant are given by

$$\begin{aligned}
& \int_{\mathcal{F}_2} \frac{d^3 \Omega_{IJ}}{(\det \text{Im } \Omega)^3} \Gamma_{2,2}^{(2)} \Big|_{n_i^I=0} \sum_{\mathbf{a}, \mathbf{b} \in \mathbb{Z}^3} C_{\mathbf{ab}} q_1^{a_1} q_2^{a_2} q_3^{a_3} \bar{q}_1^{b_1} \bar{q}_2^{b_2} \bar{q}_3^{b_3} \approx \\
& \int_{\sim 1}^{\infty} \int_{\sim 1}^{L_3} \int_0^{L_1} \frac{dL_2 dL_1 dL_3}{(\det \text{Im } \Omega)^3} T_2^2 \sum_{\ell_i^I, \mathbf{a} \in \mathbb{Z}^3} C_{\mathbf{aa}} e^{-4\pi(a_1 L_1 + a_2 L_2 + a_3 L_3)} \\
& \times \exp \left\{ -\frac{\pi T_2}{U_2 \det \text{Im } \Omega} [(\ell_1^1 + \ell_2^1)^2 L_3 + (\ell_1^2 + \ell_2^2)^2 L_1 + (l_1^1 + l_2^1 - l_1^2 - l_2^2)^2 L_2] \right. \\
& \quad \left. - \frac{\pi T_2 U_2}{\det \text{Im } \Omega} [(\ell_2^1)^2 L_3 + (\ell_2^2)^2 L_1 + (l_2^1 - l_2^2)^2 L_2] \right\} \quad (4.2.28)
\end{aligned}$$

In the regions of the fundamental domain in which the real parts of the three moduli are integrated from $-1/2$ to $1/2$, the only non-zero contributions come from the physical states with $a_i = b_i \geq 0$, and are given by the physical coefficients $C_{\mathbf{aa}}$. (This result is also a consequence of the fact that modular invariance requires $a_i - b_i \in \mathbb{Z}$.) The approximation sign is there because, as was also the case for one-loop integrals, there is a small region of the fundamental domain for which the integration over the real parts of the moduli does not extend over the full domain $-1/2 < \text{Re}(\Omega_{IJ}) \leq 1/2$. In this region, there is no level-matching and so unphysical states contribute to the vacuum amplitude. Nevertheless as in ref.[7], we find that the contributions from these unphysical states are also extremely exponentially suppressed compared to the both the massless contributions *and* the lowest lying string excitation mode contribution, provided that the compactification radii are sufficiently large.

As per the previous subsection we are therefore interested in the value of

C_{00} , the coefficient of the constant piece giving leading order contributions. The important observation is that for these massless modes (with $a_1 = a_2 = a_3 = 0$) the expression in Equation 4.2.28 has simply degenerated to the 4 dimensional field-theory result in the Schwinger formalism, so the coefficient C_{00} could also be calculated in the effective 6D→4D Scherk-Schwarz field-theory. The relevant diagrams are shown together with the coefficients of their contribution to C_{00} in Figure 4.3, which are deduced from the calculations in ref.[161]. (Note that all coefficients are written for the fields as they decompose into boson or fermionic components of $\mathcal{N} = 2$ multiplets.)

Different limits of the integral in Equation 4.2.28 generate *all* the field-theory diagrams in Figure 4.3. In particular the “double-bubble” diagrams come from the region where $L_1, L_3 \rightarrow \infty$, while $L_2 \gtrsim 1$. Explicitly in this limit, one still requires $a_1 = a_2 = a_3 = 0$ to avoid exponential suppression, but can everywhere replace $\det \text{Im } \Omega \approx L_1 L_3$. The L_2 integral then may be trivially performed (with its upper limit L_1 being effectively infinite). Taking for example $\ell_2^2 = \ell_1^1 = 1$ in this limit results in an integral proportional to

$$\approx \int_{\sim 1}^{\infty} \int_{\sim 1}^{L_3} \frac{dL_1 dL_3}{L_1^2 L_3^2} C_{00} \exp \left\{ -\frac{\pi T_2 U_2}{L_3} - \frac{\pi T_2}{U_2 L_1} \right\},$$

which (taking the upper limit $L_3 \rightarrow \infty$ on the L_1 integral) has the form of a product of two one-loop Poisson resummed Schwinger integrals in a KK theory with two extra dimensions. A more complete way to reach this conclusion would be to first go to the “non-separating degeneration” limit of ref.[154], i.e. $\tau_{22} \rightarrow i\infty$ with τ_{11}, τ_{12} fixed, and from there take $\tau_{11} \rightarrow i\infty$.

The field theory recipe for evaluating C_{00} for the Scherk-Schwarz string theories is therefore as follows: *retain in the list of two-loop diagrams only those that are exactly massless, meaning that the states on all propagators do not receive any CDC shift. Then C_{00} is precisely twice the resulting sum of coefficients.*

The reasoning is straightforward and exactly mirrors what happens in the one-loop case. First recall that we are (for this calculation) considering only untwisted states in the diagrams of Figure 4.3. This implies that there is KK and

e charge conservation at the vertices, which in turn implies that the CDC shifts *pairs* of either Fermion-Fermion or Boson-Boson masses on the sunset diagrams. The nett effect of such a shift is that the space-time statistics of an entire loop on the diagram is reversed, and consequently these diagrams contribute with an additional minus sign. Meanwhile the “superpartner” diagram (in which the space-time statistics *really is* reversed on that loop) is still present: hence a factor of two.

In principle the sum of coefficients can vanish, and the important aspect that makes this possible is the coupling degeneracy, which is due to the underlying supersymmetry of the undeformed theory, and the $\mathcal{N} = 2$ structure of the un-twisted (i.e. SUSY breaking) sector. This is a well-known feature of effective string theories, but the crucial point here is that while at the level of the field theory a complete cancellation of contributions may seem like a miraculous tuning, at the level of the string theory it is merely a consequence of the particle content and the corresponding partition function and measure (and indeed there *are* no independent couplings). It is worth repeating that from this point of view (and in practice), it is far easier simply to work with the q -expansion of the string partition function, than to attempt to evaluate C_{00} for the entire field theory.

4.2.5 The separating degeneration limit

There is one limit that would not be covered by the field theoretic treatment described in the previous sub-section, namely the separating degeneration limit. For a two-loop string vacuum amplitude this corresponds to taking the limit $\tau_{12} \rightarrow 0$ keeping τ_{11}, τ_{22} fixed. This gives a Riemann surface that looks like two one-loop vacuum amplitudes connected by a long thin tube, as shown in Figure 4.4. The limits of various objects appearing in the two-loop cosmological

constant are given by [154]

$$\begin{aligned}
\vartheta[\mu_1, \mu_2](\Omega) &= \vartheta_1[\mu_1](0, \tau_{11})\vartheta_1[\mu_2](0, \tau_{22}) + \mathcal{O}(\tau_{12}^2), \\
\vartheta[\nu_0, \nu_0](\Omega) &= -2\pi i\tau_{12}\eta(\tau_{11})^3\eta(\tau_{22})^3 + \mathcal{O}(\tau_{12}^3), \\
\Xi_6[\mu_1, \mu_2](\Omega) &= -2^8\langle\mu_1|\nu_0\rangle\langle\mu_2|\nu_0\rangle\eta(\tau_{11})^{12}\eta(\tau_{22})^{12} + \mathcal{O}(\tau_{12}^2), \\
\Xi_6[\nu_0, \nu_0](\Omega) &= -3 \cdot 2^8\eta(\tau_{11})^{12}\eta(\tau_{22})^{12} + \mathcal{O}(\tau_{12}^2), \\
\Psi_{10}(\Omega) &= -(2\pi\tau_{12})^2 2^{12}\eta(\tau_{11})^{24}\eta(\tau_{22})^{24} + \mathcal{O}(\tau_{12}^4),
\end{aligned} \tag{4.2.29}$$

where $\mu_{1,2,3}$ and ν_0 are the three even and unique odd genus 1 spin structures respectively, while the genus two Narain lattice $\Gamma_{2,2}^{(2)}$ splits into a product of two genus one Narain lattices. Therefore the full two-loop cosmological constant in

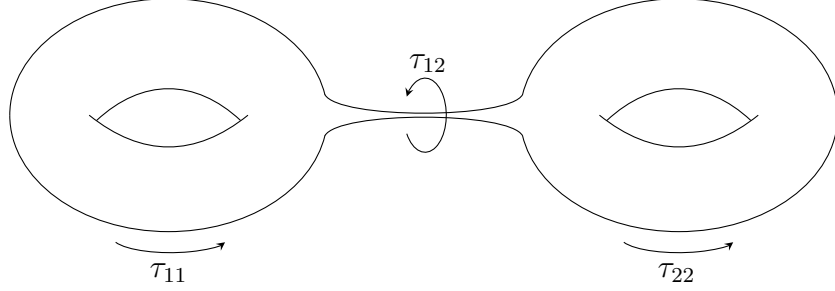

Figure 4.4: The separating degeneration limit.

the separating degeneration limit takes the form

$$\begin{aligned}
\Lambda &= \int \frac{d^2\tau_{11}d^2\tau_{22}d^2\tau_{12}}{(\text{Im}(\tau_{11})\text{Im}(\tau_{22}))^3} \sum_{\{\alpha^i, \beta^i\}} \tilde{C} \begin{bmatrix} \alpha \\ \beta \end{bmatrix} \frac{1}{2^{18}\pi^4|\tau_{12}|^4} \frac{1}{\eta(\tau_{11})^{12}\eta(\tau_{22})^{12}\bar{\eta}(\tau_{11})^{24}\bar{\eta}(\tau_{22})^{24}} \\
&\times \Gamma_{2,2}^{(1)}(\tau_{11})\Gamma_{2,2}^{(1)}(\tau_{22}) \prod_{\eta \in F'_R} \vartheta_1^{1/2} \begin{bmatrix} (\alpha^1 \nu)' \\ (\beta^1 \nu)' \end{bmatrix} \vartheta_1^{1/2} \begin{bmatrix} (\alpha^2 \nu)' \\ (\beta^2 \nu)' \end{bmatrix} \prod_{\check{\phi} \in F'_L} \bar{\vartheta}_1^{1/2} \begin{bmatrix} (\alpha^1 \nu)' \\ (\beta^1 \nu)' \end{bmatrix} \bar{\vartheta}_1^{1/2} \begin{bmatrix} (\alpha^2 \nu)' \\ (\beta^2 \nu)' \end{bmatrix} + \mathcal{O}\left(\frac{1}{\tau_{12}}\right),
\end{aligned} \tag{4.2.30}$$

which is essentially two one-loop vacuum amplitudes connected by a divergent propagator. We therefore make the crucial conclusion that the separating degeneration limit contains the divergence due to any uncanceled one-loop dilaton tadpoles. In general, i.e. at higher loop order, one expects such terms to always be present. That is at n -loop order, any uncanceled tadpoles from the $(n-1)$ -loop theory will contribute to divergences in the cosmological constant. Thus if the one-loop partition function has Bose-Fermi degeneracy, these terms are a

divergence multiplied by an exponentially suppressed coefficient.

One may confirm that the same conclusion is arrived at using the full q -expansion in the separating degeneration limit. First of all in this limit we have

$$\frac{2^{12}}{\Psi_{10}} = -\frac{1}{(2\pi\tau_{12})^2} \left(\frac{1}{q_1 q_3} + \frac{24}{q_1} + \frac{24}{q_3} + 576 + \mathcal{O}(q_I) \right). \quad (4.2.31)$$

Returning to the non-SUSY $SO(10)$ model with massless Bose-Fermi degeneracy given in Appendix C, for the untwisted sector with $\ell^{1,2}$ odd, the leading term in the q -expansion of the partition function after summing over spin structures is given by

$$\begin{aligned} \aleph &= \frac{1}{|\Psi_{10}|^2} \left(-\frac{1}{4} + 6q_1 + 6q_3 - 144q_1q_3 + \dots \right) (\bar{q}_1\bar{q}_2 + \dots) \\ &= \frac{1}{|2\pi\tau_{12}|^4} \left(-\frac{576}{4} + 6 \cdot 24 + 6 \cdot 24 - 144 + \mathcal{O}(q_I) \right) (1 + \mathcal{O}(\bar{q}_I)) \\ &= 0 + \frac{\mathcal{O}(q_I) (1 + \mathcal{O}(\bar{q}_I))}{|2\pi\tau_{12}|^4}. \end{aligned} \quad (4.2.32)$$

The constant term has vanished as expected in this limit, for this model.

4.2.6 Comments on the effect of the one-loop tadpole

For the class of non-SUSY string models that we are considering in this chapter, it is known that at one-loop order there is an exponentially suppressed but non-zero dilaton tadpole. If this tadpole is left uncancelled, then as we saw in the previous section, it can contribute through the separating degeneration as a divergence in the two-loop cosmological constant. It is well known that infrared divergences can appear in this degeneration [162–164], however, our experience from QFT is that these divergences typically arise because we are asking the wrong questions. As we have learned from QFT, what one should in principle do is stabilise the theory in the correct one-loop vacuum so that the tadpole is effectively cancelled. The two loop separating degeneration divergence would then be seen to be merely an artifact that disappears if we perform this procedure. It might also be the case that one could live with the tadpole and have a dynamical cosmologically evolving background as in ref. [165]. These issues have also been discussed in

refs. [166–168].

In generic non-supersymmetric string models the dilaton tadpoles can be large. Any attempt to cancel the tadpole through a background redefinition would require such a large shift that it is highly unlikely that the new vacuum bears any resemblance to the original, thereby negating any positive phenomenological aspects of the originally constructed model. The key point about the specific types of models we consider here is that the dilaton tadpoles are exponentially suppressed. If one were to employ a background redefinition, the shift to achieve this should be sufficiently small so as not to result in any appreciable alteration in the phenomenological properties, including the spectrum of the massless states. If this were not the case then clearly there would be a problem, since the construction of models with suppressed cosmological constants is dependent on a careful cancellation of bosonic and fermionic massless degrees of freedom at one-loop order. In theory one is able to perform this background shift at the string theory level (see ref.[169]), however in practice this would be rather involved.

An alternative argument is built around balancing the one-loop tadpole itself against another contribution as in ref. [52] where the mechanism is incorporated in the effective supergravity theory, and of course should not itself result in a large cosmological constant. In a framework that is completely stable, where the dilaton tadpole is cancelled, the divergent contribution to the two-loop cosmological constant should then vanish, while crucially the remaining contributions remain unaltered. For the models which contain a bose-fermi degeneracy, the potential can be written as

$$V = V_{\text{IR}} + V_{\text{UV}}, \quad (4.2.33)$$

where V_{UV} is computed in the full string theory while V_{IR} arises from non-perturbative effects in the effective field theory. The key point is that because V_{UV} comes from the contribution of heavy modes only, it is independent of the low-energy IR physics. Therefore, we can introduce some stabilising mechanism in the IR to cancel the UV contribution, and provided this does not alter the masses of states in any way that is not exponentially suppressed, then the mass-

less spectrum will remain unchanged.

A full treatment of the tadpole is beyond the scope of this work and so a complete study of the dynamics is left to future work. With this in mind, we assume it is fact consistent to study the cosmological constant in our naive vacuum, with the knowledge that the conditions on the structure of the massless spectrum that guarantee exponential suppression will still be satisfied after the shift to the correct vacuum. We emphasise that this would not be the case without exponential suppression of the one-loop tadpole. Those theories would undergo large shifts in the metric upon finding their true vacua, and any putative dilaton stabilisation would most likely be completely invalidated in the process, along with any two-loop discussion.

4.2.7 Suppression of the “mixed” diagrams

This completes the derivation and discussion of the first criterion for vanishing two-loop cosmological constant. It remains to consider the contributions with one untwisted propagator and two twisted ones, i.e. the mixed diagrams. In the untwisted sector, the compactification from 6D to 4D resulted in the inclusion of the two-loop Narain partition function for the two compact bosonic degrees of freedom. This term meant that, for sufficiently large compactification radii, contributions to the cosmological constant from non-level matched states (including the proto-graviton) were exponentially suppressed compared to contributions from both massless states and the lowest lying string excitation modes. By contrast, for the twisted sectors, the partition function for the two compact bosonic degrees of freedom is given by [155, 170]

$$\mathcal{Z}[\epsilon] = \mathcal{Z}^{\text{qu}}[\epsilon] \sum_{(p_L, p_R) \in \Gamma} \exp \left\{ \pi i \left(p_L^2 \tau_\epsilon - p_R^2 \bar{\tau}_\epsilon \right) \right\} \quad (4.2.34)$$

where τ_ϵ is the Prym period and

$$\mathcal{Z}^{\text{qu}}[\epsilon] = \left| \frac{\vartheta[\delta_i^+](0, \Omega) \vartheta[\delta_i^-](0, \Omega)}{Z(\Omega)^2 \vartheta_i(0, \tau_\epsilon)^2} \right| \quad (4.2.35)$$

where $Z(\Omega)$ is the partition function for two bosonic degrees of freedom in the uncompactified theory.

For twisted sectors involving some twist on only one of the two loops we anticipate that the cosmological constant may still receive a non-zero contribution. First we can see that again it is the massless states which provide the dominant contributions to the cosmological constant, while massive states receive exponential suppression after integrating over the real parts of the three moduli as before. The contributions from non-level matched (i.e. unphysical) states are also exponentially suppressed (for sufficiently large compactification radii), despite the fact these sectors do not include the two-loop Narain partition function. Instead, in these sectors there is the factor,

$$\Gamma_{2,2}^{(1)}(\tau_\epsilon) = \sum_{(p_L, p_R)} \exp \left\{ \pi i \left(p_L^2 \tau_\epsilon - p_R^2 \bar{\tau}_\epsilon \right) \right\} \quad (4.2.36)$$

which just has the form of a one-loop Narain partition function involving the Prym period τ_ϵ . As usual we can perform a Poisson resummation giving

$$\Gamma_{2,2}^{(1)}(\tau_\epsilon) = \frac{T_2}{\tau_\epsilon} \sum_{\vec{l}, \vec{n}} \exp \left\{ -\frac{\pi T_2}{\tau_\epsilon U_2} |l_1 - n_1 \tau_\epsilon + (l_2 - n_2 \tau_\epsilon) U|^2 \right\}. \quad (4.2.37)$$

In order to show that the unphysical states are suppressed even in the twisted sectors, we make use of the fact that there is a relation between the Prym period τ_ϵ and the period matrix Ω . The Schottky relations state that for any $i, j = 2, 3, 4$

$$\frac{\vartheta_i(0, \tau_\epsilon)^4}{\vartheta_j(0, \tau_\epsilon)^4} = \frac{\vartheta[\delta_i^+](0, \Omega)^2 \vartheta[\delta_i^-](0, \Omega)^2}{\vartheta[\delta_j^+](0, \Omega)^2 \vartheta[\delta_j^-](0, \Omega)^2}. \quad (4.2.38)$$

In the notation above, for any given twist $\epsilon \neq 0$, there are 6 even spin structures δ where $\delta + \epsilon$ is also even. These 6 spin structures are denoted δ_i^+ and δ_i^- , for $i = 2, 3, 4$, where $\delta_i^- = \delta_i^+ + \epsilon$. The region of moduli space where there is no level-matching is when L_1, L_2, L_3 are all sufficiently small and are at most $\mathcal{O}(1)$. When the imaginary parts of the three moduli are small, the Schottky relations tell us that $\text{Im}(\tau_\epsilon)$ is also small (while it is large when both L_1 and L_3 are sufficiently large) and so by considering the Poisson resummed form of $\Gamma_{2,2}^{(1)}(\tau_\epsilon)$ we see that small values of τ_ϵ result in exponential suppression.

What remains therefore are the diagrams with a twisted loop and an untwisted propagator containing only physical states. (Due to the \mathbb{Z}_2 orbifold, there can only be either UUU or TTU vertices in the superpotential of the unbroken theory, and hence no diagrams with a single twisted propagator.) The coefficients of these diagrams can be easily evaluated in the field theory. The integral for a loop of fermions of mass m_1 and m_2 coupling to a scalar are of the form

$$\Sigma(k^2) = -i \int \frac{d^4q}{(2\pi)^4} \frac{\not{q} + m_1}{q^2 - m_1^2} \frac{(\not{q} + \not{k}) + m_2}{(q+k)^2 - m_2^2}. \quad (4.2.39)$$

We can assume one mass to be zero, and first consider the fermion as the KK states. Thus we have to consider the Euclideanised integrals

$$I_{T_f T_s U_f} = 2 \int \frac{d^4q}{(2\pi)^4} \int \frac{d^4k}{(2\pi)^4} \frac{q \cdot (q+k)}{q^2 k^2} \frac{1}{(q+k)^2 + m_f^2}. \quad (4.2.40)$$

We also have the case where the scalar is the KK state which involve the integral

$$I_{T_f T_f U_s} = \int \frac{d^4q}{(2\pi)^4} \int \frac{d^4k}{(2\pi)^4} \frac{q \cdot (q+k)}{q^2} \frac{1}{(k^2 + m_s^2)} \frac{1}{(q+k)^2}. \quad (4.2.41)$$

These diagrams will come with a coefficient $\text{Tr} Y_{UTT}^2$ where Y_{UTT} is the tree-level UTT Yukawa coupling in the superpotential; it takes the value $\sqrt{2}g_{YM}$ or 0 depending on whether the charges are conserved at the vertex. The double-bubble diagrams (for Yukawas) will have the same coefficient with a minus sign

$$J_{T_s T_s} = - \int \frac{d^4q}{(2\pi)^4} \int \frac{d^4k}{(2\pi)^4} \frac{1}{q^2} \frac{1}{k^2}. \quad (4.2.42)$$

$$J_{T_s U_s} = -2 \int \frac{d^4q}{(2\pi)^4} \int \frac{d^4k}{(2\pi)^4} \frac{1}{q^2} \frac{1}{k^2 + m_s^2}. \quad (4.2.43)$$

In the untwisted sector, it is possible to show that the sunset diagrams can be reduced to the form of scalar double-bubble diagrams by basic manipulation [161]. However, similar manipulations do not produce the same result in the twisted sectors and so we must evaluate the sunset diagrams as they are. Using the Schwinger formula

$$\frac{1}{A^\nu} = \frac{1}{\Gamma(\nu)} \int_0^\infty dy y^{\nu-1} \exp(-yA), \quad \text{Re}(A) > 0, \quad (4.2.44)$$

and the integrals

$$\int \frac{d^4 q}{(2\pi)^4} q^{2n} \exp(-\alpha q^2) = \frac{\Gamma[2+n]}{\alpha^{2+n} 16\pi^2}, \quad (4.2.45)$$

we find that the sunset diagrams can be written in the following form, where either $m_s = 0$ if the single untwisted propagator is a fermion, or $m_f = 0$ if it is a scalar:

$$I = -\frac{i}{(16\pi^2)^2} \int_0^\infty dy_1 dy_2 dy_3 e^{-y_3 m_s^2 - y_2 m_f^2} \times \frac{2y_3}{(y_1 y_2 + y_1 y_3 + y_2 y_3)^3}. \quad (4.2.46)$$

The above integral has UV divergences when at least two of the Schwinger parameters y_1, y_2, y_3 approach zero. Therefore, when we come to evaluate these diagrams later we will introduce a regulator $e^{-N\left(\frac{1}{y_2} + \frac{1}{y_3}\right)}$.

Figure 8 diagrams

We may proceed to calculate the relevant integrals in a similar manner to refs.[171, 172]. In the untwisted sector the scalar figure 8 diagram is proportional to $J(m_{B_l}^2)^2$ where

$$J(m_{B_m}^2) = \sum_{m_i \in \mathbb{Z}} \int \frac{d^4 p}{(2\pi)^4} \frac{1}{p^2 + m_{B_m}^2}. \quad (4.2.47)$$

We need to consider the case with two compact dimensions with radii R_1 and R_2 . We will begin by considering the supersymmetric case in order to verify cancellation between all diagrams. For the scalar mass we therefore have

$$m_{B_\ell}^2 = \frac{4m_1^2}{R_1^2} + \frac{4m_2^2}{R_2^2}, \quad (4.2.48)$$

where m_1 and m_2 are Kaluza-Klein numbers. Therefore, again making use of the Schwinger formula and integrating over the momentum p we obtain

$$J(m_{B_\ell}^2) = \frac{1}{16\pi^2} \sum_{m_i \in \mathbb{Z}} \int_0^\infty dt \frac{1}{t^2} e^{-4\left(\frac{m_1^2}{R_1^2} + \frac{m_2^2}{R_2^2}\right)t} \quad (4.2.49)$$

To proceed with the calculation we introduce a regulator $e^{-N/t}$, allowing us to interchange the order of summation and integration. From there we can perform

a Poisson resummation on the KK numbers and finally obtain

$$\begin{aligned} J(m_{B_\ell}^2) &= \frac{1}{16\pi^2} \int_0^\infty dt \frac{1}{t^2} \frac{\pi R_1 R_2}{4t} \sum_{\ell_i \in \mathbb{Z}} e^{-\frac{\pi^2}{4t}(R_1^2 \ell_1^2 + R_2^2 \ell_2^2)} e^{-\frac{N}{t}} \\ &= \frac{1}{16\pi^2} \left[\frac{\pi R_1 R_2}{4N^2} - \frac{4E(iU_2, 2)}{\pi^3 R_1 R_2} + \frac{32NE(iU_2, 3)}{\pi^5 R_1^2 R_2^2} \right] \end{aligned} \quad (4.2.50)$$

where $U_2 = R_2/R_1$ and $E(U, n)$ is the real analytic Eisenstein series with $U = U_1 + iU_2$

$$E(U, n) = \sum'_{\ell_1, \ell_2} \frac{U_2^n}{|\ell_1 + \ell_2 U|^{2n}}. \quad (4.2.51)$$

For a twisted loop there are no associated KK states and so we only have the contribution from the massless state. In this case we simply have $J = \frac{1}{16\pi^2 N}$ and so for the figure 8 diagram with a single twisted loop we find

$$J_{T_s U_s} = \frac{1}{(16\pi^2)^2} \left[\frac{\pi R_1 R_2}{4N^3} - \frac{4E(iU_2, 2)}{\pi^3 R_1 R_2 N} + \frac{32E(iU_2, 3)}{\pi^5 R_1^2 R_2^2} \right]. \quad (4.2.52)$$

Sunset diagram

When the untwisted propagator in the sunset diagram is a scalar we obtain the result

$$\begin{aligned} I_s &= -\frac{1}{(16\pi^2)^2} \sum_{m_i \in \mathbb{Z}} \int_0^\infty dy_1 dy_2 dy_3 e^{-y_3 m_s^2} \times \frac{2y_3}{(y_1 y_2 + y_1 y_3 + y_2 y_3)^3} e^{-N\left(\frac{1}{y_2} + \frac{1}{y_3}\right)} \\ &= -\frac{1}{(16\pi^2)^2} \left(\frac{\pi R_1 R_2}{12N^3} - \frac{16}{\pi^5 R_1^2 R_2^2} \left[\left(3 + 2 \log \frac{N}{\pi^2}\right) E(iU_2, 3) + E^{(0,1)}(iU_2, 3) \right] \right. \\ &\quad \left. - \frac{4E(iU_2, 2)}{\pi^3 R_1 R_2 N} + \frac{32E(iU_2, 3)}{\pi^5 R_1^2 R_2^2} \right), \end{aligned} \quad (4.2.53)$$

where the notation $E^{(0,1)}(U, n) \equiv \partial_n E(U, n)$. On the other hand when the untwisted propagator is a fermion we have

$$\begin{aligned} I_f &= -\frac{1}{(16\pi^2)^2} \sum_{m_i \in \mathbb{Z}} \int_0^\infty dy_1 dy_2 dy_3 e^{-y_2 m_f^2} \times \frac{2y_3}{(y_1 y_2 + y_1 y_3 + y_2 y_3)^3} e^{-N\left(\frac{1}{y_2} + \frac{1}{y_3}\right)} \\ &= -\frac{1}{(16\pi^2)^2} \left(\frac{\pi R_1 R_2}{6N^3} + \frac{16}{\pi^5 R_1^2 R_2^2} \left[\left(3 + 2 \log \frac{N}{\pi^2}\right) E(iU_2, 3) + E^{(0,1)}(iU_2, 3) \right] \right). \end{aligned} \quad (4.2.54)$$

Therefore the total contribution from the sunset diagrams with unbroken supersymmetry is

$$I_s + I_f = -\frac{1}{(16\pi^2)^2} \left\{ \frac{\pi R_1 R_2}{4N^3} - \frac{4E(iU_2, 2)}{\pi^3 R_1 R_2 N} + \frac{32E(iU_2, 3)}{\pi^5 R_1^2 R_2^2} \right\} \quad (4.2.55)$$

which exactly cancels the contribution from the figure 8 diagram as expected.

Finally we can obtain the two-loop contribution to the vacuum energy from the twisted diagrams in a theory with supersymmetry broken by the Scherk-Schwarz mechanism. The masses of the twisted states themselves are unaffected by the supersymmetry breaking, but the masses of the untwisted states to which they couple may still be shifted. The result of Scherk-Schwarz supersymmetry breaking amounts to shifting the KK numbers by $\frac{1}{2}$. We may proceed with the calculation in the same way as before, and find the shift in the KK numbers results in a replacement of the real analytic Eisenstein series $E(U, n)$ by $E_{\frac{1}{2}}(U, n)$, where

$$E_{\frac{1}{2}}(U, n) = \sum'_{\ell_1, \ell_2} \frac{U_2^n e^{\pi i(\ell_1 + \ell_2)}}{|\ell_1 + \ell_2 U|^{2n}}. \quad (4.2.56)$$

Therefore, we find the contribution from the twisted sectors to be

$$\text{Tr}(Y_{UTT}^2) N^T \frac{(N_b^U - N_f^U)}{16\pi^9 R_1^2 R_2^2} \left[\left(3 + 2 \log \frac{N}{\pi^2}\right) \tilde{E}(iU_2, 3) + \tilde{E}^{(0,1)}(iU_2, 3) \right] \quad (4.2.57)$$

where $\tilde{E}(U, n)$ is an Eisenstein series restricted to $l_1 + l_2 = \text{odd}$, N^T is the number of twisted degrees of freedom, and N_b^U and N_f^U denote the number of untwisted bosons and fermions respectively that couple to the twisted states and whose masses remain unshifted after supersymmetry breaking. Therefore, we see that if the spectrum contains a degeneracy in the number of massless bosons and fermions in the untwisted sector that couple to twisted states, then the leading contribution from the twisted sectors is zero. Noting that the functional form of this term makes it unnatural for it to cancel against the entirely untwisted contribution, this gives us a second criterion for the vanishing of the two-loop cosmological constant: $\mathfrak{C} = 0$ where in terms of the couplings we have

$$\mathfrak{C} = \sum_{U=\text{massless}} (-1)^{F_U} \text{Tr}|Y_{UTT}|^2, \quad (4.2.58)$$

and where for a given U , the coupling Y_{UTT} is considered to be a matrix with indices running over all the twisted states, and includes both gauge and Yukawa couplings. Taking account of the degeneracy in the couplings, we can write a simple operational expression for \beth , namely

$$\beth = \sum_{U,T,T'=\text{massless}} (-1)^{F_U} \delta_Q(\mathbf{Q}_U + \mathbf{Q}_T + \mathbf{Q}_{T'}), \quad (4.2.59)$$

where the sum is over all massless physical untwisted fields, and pairs of twisted fields. The δ_Q -function imposes *either* simple charge conservation for the charge vectors of the triplet of fields (i.e. representing superpotential $\phi\bar{\psi}_L\psi'_R$ type couplings), *or* charge conservation with an extra unit in the non-compact space-time index (representing gauge $A^\mu\bar{\psi}_L\gamma_\mu\psi'_L$ type couplings that have an extra Dirac matrix).

4.3 Conclusion

In this chapter we have derived two criteria for the exponential suppression of the two-loop cosmological constant in string theories with spontaneously broken supersymmetry. These two criteria determine respectively when the leading order entirely untwisted and partially twisted contributions vanish. The untwisted criterion, in Equation 4.2.23, is most easily determined in any given model from the vanishing of the constant term in the q -expansion of the integrand in the two-loop cosmological constant. Note that this object contains factors from the partition function but also from the measure; the criterion can not be determined from the partition function alone. The twisted criterion can be determined from the effective field theory, but can most easily be evaluated in a very simple operational way simply with the knowledge of the states in the spectrum and all of their charges. The resulting condition, in Equation 4.2.58, is the vanishing of a “sum of Veltman conditions” for the twisted fields; that is, in terms of the effective field theory, one can imagine that at the one-loop level the twisted states in the spectrum will receive quadratically divergent contributions to their mass from

the leading quadratic divergence in the cosmological constant. At the two-loop level, these terms will enter into “sunset” diagrams, but the degenerate nature of the couplings implies that the sum of such contributions may vanish, depending on the spectrum.

For consistency, one should also impose the vanishing of the one-loop leading contribution to the cosmological constant, which is achieved in theories that have Bose-Fermi degeneracy in their massless physical states. Divergences associated with the one-loop dilaton tadpole would appear at two loop level in the so-called separating degeneration limit of the diagrams, a limit that resembles two one-loop torus diagrams connected by a long thin tube. However, their presence does not actually affect the phenomenology of these models since the crucial point is that because the tadpoles are exponentially suppressed, their effect on the physical spectrum is in fact negligible.

The two criteria we have presented here can be thought of as a stringy implementation of the “naturalness without supersymmetry” idea first proposed in ref.[53] up to the two-loop level. The existence or otherwise of models that satisfy these conditions, and their properties should they exist, is a subject of current study, which will be reported elsewhere [173].

It would also be of interest to search for a subset of theories that mimic the supertrace rules in models involving D3-branes, where vanishing one-loop supertraces are known to extend to higher order automatically [174].

Chapter 5

Summary

This thesis has detailed how explicit calculations of both one and two loop amplitudes in heterotic string can be used to test the phenomenological properties and viability of given classes of string models.

In chapter 3 we considered models that included compactification of two dimensions on a \mathbb{T}_2 torus. We computed one-loop two-point amplitudes involving the Kähler and complex structure moduli as external states, which allowed us to determine the one-loop corrections to the Kähler potential. Previous observations of the tree-level Kähler potential showed that it contained a non-compact shift symmetry. Prior to performing any calculations, we reasoned that while this shift symmetry would not necessarily be guaranteed to hold beyond tree-level in general, we anticipated it would do so in a particular limit of the moduli space. Indeed through an explicit one-loop computation we were able to show that the shift symmetry only holds in this limit. We conjecture that the symmetry should also hold in this limit to all orders in perturbation theory.

In chapter 4 we carried out a study of the cosmological constant in non-supersymmetric heterotic string models. We considered a class of models that have been shown to have an exponentially suppressed value of the cosmological constant to one-loop order. The question was whether this exponential suppression continues to higher orders, or if not, are there further conditions that one can impose so that it will.

Two-loop superstring calculations are notoriously more complex than their one-loop counterparts, primarily due to the presence of supermoduli. Nevertheless, after integrating out the supermoduli, one may work in a formulation that has many similarities with the corresponding one-loop amplitude in terms of Jacobi theta functions. In this way we have demonstrated that it is still possible to perform explicit computations at this order.

For the models under consideration, the dominant contribution to the cosmological constant comes from the massless states, while contributions from both massive and unphysical states are exponentially suppressed. This is similar to what was previously found at one-loop, however at two-loop order twisted sectors can potentially give large contributions. In the untwisted sector, we were able to explicitly compute the q -expansions for individual models. The first condition for exponential suppression is that the constant term in such an expansion must vanish. For the twisted sectors, it proved simpler to instead work in the effective field theory, where a second condition was found, namely the requirement of the vanishing of a “sum of Veltman conditions” for the twisted fields. In addition, clearly the one-loop cosmological constant must also be exponentially and in fact is also a requirement so that one-loop dilaton tadpoles do not have divergent contributions at higher order. It would be highly desirable to find a particular example that satisfied these conditions, so that one could analyse its spectrum and gauge group. However, it must be left to further investigation as to the existence of such models or whether there is systematic way of finding them.

Appendix A

Jacobi theta functions

The ϑ -functions with characteristics are defined as

$$\vartheta \begin{bmatrix} a \\ b \end{bmatrix} (z, \tau) \equiv \sum_{n=-\infty}^{\infty} e^{2\pi i(n+a)(z+b)} q^{(n+a)^2/2}, \quad (\text{A.1})$$

where $q = \exp(2\pi i\tau)$. For particular values of $a, b \in \{0, \frac{1}{2}\}$, these functions are often denoted by

$$\begin{aligned} \vartheta_{11} &\equiv \vartheta \begin{bmatrix} 1/2 \\ 1/2 \end{bmatrix} = -\vartheta_1, \\ \vartheta_{10} &\equiv \vartheta \begin{bmatrix} 1/2 \\ 0 \end{bmatrix} = \vartheta_2, \\ \vartheta_{00} &\equiv \vartheta \begin{bmatrix} 0 \\ 0 \end{bmatrix} = \vartheta_3, \\ \vartheta_{01} &\equiv \vartheta \begin{bmatrix} 0 \\ 1/2 \end{bmatrix} = \vartheta_4. \end{aligned} \quad (\text{A.2})$$

The Dedekind eta function is given by

$$\eta(\tau) \equiv q^{1/24} \prod_{n=1}^{\infty} (1 - q^n). \quad (\text{A.3})$$

The behaviour of the theta functions under modular transformations are given by

$$\begin{aligned} \vartheta \begin{bmatrix} a \\ b \end{bmatrix} (z, \tau + 1) &= e^{-\pi i a(a+1)} \vartheta \begin{bmatrix} a \\ a+b+1/2 \end{bmatrix} (z, \tau), \\ \vartheta \begin{bmatrix} a \\ b \end{bmatrix} (z, -1/\tau) &= \sqrt{-i\tau} e^{2\pi i a b} e^{\pi i \tau z^2} \vartheta \begin{bmatrix} -b \\ a \end{bmatrix} (-z\tau, \tau), \end{aligned} \quad (\text{A.4})$$

while for the Dedekind eta function they are

$$\begin{aligned}\eta(\tau + 1) &= e^{\frac{2\pi i}{24}} \eta(\tau), \\ \eta(-1/\tau) &= \sqrt{-i\tau} \eta(\tau).\end{aligned}\tag{A.5}$$

The theta functions satisfy the identities

$$\vartheta_2 \vartheta_3 \vartheta_4 = 2\eta^3,\tag{A.6}$$

$$\vartheta_2^4 - \vartheta_3^4 + \vartheta_4^4 = 0,\tag{A.7}$$

where we always denote $\vartheta_{ab}(\tau) \equiv \vartheta_{ab}(0, \tau)$.

The Weierstrass function is defined by

$$\wp(z) = 4\pi i \partial_\tau \log \eta(\tau) - \partial_z^2 \log \vartheta_1(z).\tag{A.8}$$

Poisson resummation

Define the Fourier transform \tilde{f} of a function $f(x)$ as

$$\tilde{f}(k) \equiv \frac{1}{2\pi} \int_{-\infty}^{\infty} f(x) e^{ikx} dx,\tag{A.9}$$

then Poisson resummation gives that

$$\sum_{n \in \mathbb{Z}} f(2\pi n) = \sum_{n \in \mathbb{Z}} \tilde{f}(n).\tag{A.10}$$

When f is a Gaussian function we have

$$\sum_{n \in \mathbb{Z}} e^{-\pi a n^2 + \pi b n} = \frac{1}{\sqrt{a}} \sum_{n \in \mathbb{Z}} e^{-\frac{\pi}{a} (n + i\frac{b}{2})^2},\tag{A.11}$$

while the multidimensional case is given by

$$\sum_{m_i \in \mathbb{Z}} e^{-\pi m_i m_j A_{ij} + \pi B_i m_i} = (\det A)^{-\frac{1}{2}} \sum_{m_i \in \mathbb{Z}} e^{-\pi (m_k + iB_k/2)(A^{-1})_{kl}(m_l + iB_l/2)}.\tag{A.12}$$

Appendix B

Two-loop theta functions and modular transformations

Letting $\tau_{11} \equiv Y_1 + Y_2$, $\tau_{12} \equiv Y_2$, $\tau_{22} \equiv Y_2 + Y_3$ and defining $q_I = \exp\{2\pi i Y_I\}$, the genus two theta functions have the following expansions in q_I up to linear order (note that the convention for cycles, $\begin{bmatrix} \alpha_{1V} & \alpha_{2V} \\ \beta_{1V} & \beta_{2V} \end{bmatrix}$, is the transpose of that used in [151–154])

$$\begin{aligned}
\vartheta \begin{bmatrix} 0 & 0 \\ 0 & 0 \end{bmatrix} &\sim 1 + 2q_1^{1/2} q_2^{1/2} + 2q_1^{1/2} q_3^{1/2} + 2q_2^{1/2} q_3^{1/2} + \dots \\
\vartheta \begin{bmatrix} 0 & 0 \\ 0 & \frac{1}{2} \end{bmatrix} &\sim 1 + 2q_1^{1/2} q_2^{1/2} - 2q_1^{1/2} q_3^{1/2} - 2q_2^{1/2} q_3^{1/2} + \dots \\
\vartheta \begin{bmatrix} 0 & 0 \\ \frac{1}{2} & 0 \end{bmatrix} &\sim 1 - 2q_1^{1/2} q_2^{1/2} - 2q_1^{1/2} q_3^{1/2} + 2q_2^{1/2} q_3^{1/2} + \dots \\
\vartheta \begin{bmatrix} 0 & 0 \\ \frac{1}{2} & \frac{1}{2} \end{bmatrix} &\sim 1 - 2q_1^{1/2} q_2^{1/2} + 2q_1^{1/2} q_3^{1/2} - 2q_2^{1/2} q_3^{1/2} + \dots \\
\vartheta \begin{bmatrix} \frac{1}{2} & 0 \\ 0 & 0 \end{bmatrix} &\sim 2q_1^{1/8} q_2^{1/8} (1 + q_3^{1/2}) + \dots \\
\vartheta \begin{bmatrix} \frac{1}{2} & 0 \\ 0 & \frac{1}{2} \end{bmatrix} &\sim 2q_1^{1/8} q_2^{1/8} (1 - q_3^{1/2}) + \dots \\
\vartheta \begin{bmatrix} 0 & \frac{1}{2} \\ 0 & 0 \end{bmatrix} &\sim 2q_2^{1/8} q_3^{1/8} (1 + q_1^{1/2}) + \dots \\
\vartheta \begin{bmatrix} 0 & \frac{1}{2} \\ \frac{1}{2} & 0 \end{bmatrix} &\sim 2q_2^{1/8} q_3^{1/8} (1 - q_1^{1/2}) + \dots \\
\vartheta \begin{bmatrix} \frac{1}{2} & \frac{1}{2} \\ 0 & 0 \end{bmatrix} &\sim 2q_1^{1/8} q_3^{1/8} (1 + q_2^{1/2}) + \dots \\
\vartheta \begin{bmatrix} \frac{1}{2} & \frac{1}{2} \\ \frac{1}{2} & \frac{1}{2} \end{bmatrix} &\sim 2q_1^{1/8} q_3^{1/8} (1 - q_2^{1/2}) + \dots
\end{aligned} \tag{B.1}$$

For ease of reference we also collect here the large radius q -expansion for the weight 10 Igusa cusp form:

$$\frac{2^{12}}{\Psi_{10}} = \frac{1}{q_1 q_2 q_3} + 2 \sum_{i < j} \frac{1}{q_i q_j} + 24 \sum_i \frac{1}{q_i} + \mathcal{O}(q_i). \quad (\text{B.2})$$

Modular transformations for a genus 2 Riemann surface form the infinite discrete group $\text{Sp}(4, \mathbb{Z})$ defined by

$$M = \begin{pmatrix} A & B \\ C & D \end{pmatrix}, \quad M \begin{pmatrix} 0 & I \\ -I & 0 \end{pmatrix} M^t = \begin{pmatrix} 0 & I \\ -I & 0 \end{pmatrix}, \quad (\text{B.3})$$

where A, B, C, D are integer valued 2×2 matrices. The Siegel upper half-plane is defined as the set of all symmetric 2×2 complex matrices with positive definite imaginary part. Modular transformations under $\text{Sp}(4, \mathbb{Z})$ act on the Siegel upper half-plane by

$$\Omega \rightarrow \tilde{\Omega} = (A\Omega + B)(C\Omega + D)^{-1}, \quad (\text{B.4})$$

giving the following transformations,

$$\begin{aligned} \vartheta[\tilde{\delta}](0, \tilde{\Omega})^4 &= \epsilon^4 \det(C\Omega + D)^2 \vartheta[\delta](0, \Omega)^4, \\ \Xi_6[\tilde{\delta}](\tilde{\Omega}) &= \epsilon^4 \det(C\Omega + D)^6 \Xi_6[\delta](\Omega), \\ \Psi_8(\tilde{\Omega}) &= \det(C\Omega + D)^8 \Psi_8(\Omega), \\ \Psi_{10}(\tilde{\Omega}) &= \det(C\Omega + D)^{10} \Psi_{10}(\Omega), \\ \det \text{Im}(\tilde{\Omega}) &= |\det(C\Omega + D)|^{-2} \det \text{Im} \Omega, \\ d^3 \tilde{\Omega} &= |\det(C\Omega + D)|^{-6} d^3 \Omega, \end{aligned} \quad (\text{B.5})$$

where $\epsilon^4 = \pm 1$.

Appendix C

$SO(10)$ model with massless Bose-Fermi degeneracy

C.1 Model definition, and vanishing of SUSY partition function

The model is defined by the following set of basis vectors \mathbf{V}_a and CDC deformation vector \mathbf{e} , which correspond to the $SO(10)$ model of ref.[7]:

$$\begin{aligned}\mathbf{V}_0 &= -\frac{1}{2}[11\ 111\ 111\ | 1111\ 111111\ 111\ 111111111] \\ \mathbf{V}_1 &= -\frac{1}{2}[00\ 011\ 011\ | 1111\ 111111\ 111\ 111111111] \\ \mathbf{V}_2 &= -\frac{1}{2}[00\ 101\ 101\ | 0101\ 00000\ 011\ 111111111] \\ \mathbf{b}_3 &= -\frac{1}{2}[10\ \bar{1}0\bar{0}\ \bar{0}0\bar{1}\ | 0001\ 111111\ 010\ 100111100] \\ \mathbf{V}_4 &= -\frac{1}{2}[00\ 101\ 101\ | 0101\ 00000\ 011\ 00000000] \\ \mathbf{e} &= \frac{1}{2}[00\ 101\ 101\ | 1011\ 00000\ 000\ 000111111],\end{aligned}\tag{C.1.1}$$

while the corresponding structure constants k_{ij} are given by

$$k_{ij} = \begin{pmatrix} 0 & 0 & 0 & \frac{1}{2} & 0 \\ 0 & 0 & 0 & \frac{1}{2} & 0 \\ 0 & \frac{1}{2} & 0 & 0 & 0 \\ \frac{1}{2} & 0 & 0 & 0 & 0 \\ 0 & \frac{1}{2} & 0 & 0 & 0 \end{pmatrix}. \quad (\text{C.1.2})$$

It is easier to verify the vanishing of the two loop cosmological constant in SUSY models by taking a set of equivalent basis vectors where V_0 and V_1 are replaced by

$$\begin{aligned} \mathbf{V}'_0 = \mathbf{V}_1 &= -\frac{1}{2}[00\ 011\ 011\ | \ 1111\ 11111\ 111\ 111111111] \\ \mathbf{V}'_1 = \overline{\mathbf{V}_0 + \mathbf{V}_1} &= -\frac{1}{2}[11\ 100\ 100\ | \ 0000\ 00000\ 000\ 000000000]. \end{aligned} \quad (\text{C.1.3})$$

Beginning with a simple model defined only by the vectors \mathbf{V}'_0 and \mathbf{V}'_1 , one finds a contribution appearing as an overall factor in the expression for the cosmological constant. This factor comes from the components corresponding to $i_R = 1, 2, 3, 6$ and is given by

$$\sum_{a,b,c,d \in \{0, \frac{1}{2}\}} \Xi_6 \begin{bmatrix} a & b \\ c & d \end{bmatrix} \vartheta \begin{bmatrix} a & b \\ c & d \end{bmatrix}^4 = 0. \quad (\text{C.1.4})$$

A similar story applies to the model defined by the three basis vectors \mathbf{V}'_0 , \mathbf{V}'_1 and \mathbf{V}_2 where the identity that now guarantees a vanishing cosmological constant is

$$\sum_{a_1, b_1, c_1, d_1 \in \{0, \frac{1}{2}\}} (-1)^{c_2 a_1 + d_2 b_1} \Xi_6 \begin{bmatrix} a_1 & b_1 \\ c_1 & d_1 \end{bmatrix} \vartheta \begin{bmatrix} a_1 & b_1 \\ c_1 & d_1 \end{bmatrix}^2 \vartheta \begin{bmatrix} a_1 + a_2 & b_1 + b_2 \\ c_1 + c_2 & d_1 + d_2 \end{bmatrix}^2 = 0, \quad (\text{C.1.5})$$

for any $a_2, b_2, c_2, d_2 \in \{0, \frac{1}{2}\}$. By inspection, this identity also guarantees a vanishing contribution to the one-loop vacuum energy of the full non-SUSY $SO(10)$ model above, from the untwisted sectors in which both $\ell^1, \ell^2 = 0 \pmod{2}$ (where $\ell^1 = \ell_1^1 + \ell_2^1$ and similar for ℓ^2).

C.2 Massless Bose-Fermi degeneracy and the 1-loop q -expansion

The one-loop partition function after the applying the CDC is proportional to

$$\mathcal{Z} \propto \frac{1}{\eta(\tau)^{12} \bar{\eta}(\bar{\tau})^{24}} \sum_{\alpha, \beta} C \begin{bmatrix} \alpha \\ \beta \end{bmatrix} \Gamma_{2,2} \Big|_{n=0} \prod_{i_R} \vartheta \begin{bmatrix} \alpha \mathbf{V}_i - n \mathbf{e}_i \\ -\beta \mathbf{V}_i + \ell \mathbf{e}_i \end{bmatrix} \prod_{i_L} \bar{\vartheta} \begin{bmatrix} \alpha \bar{\mathbf{V}}_i - n \mathbf{e}_i \\ -\beta \bar{\mathbf{V}}_i + \ell \mathbf{e}_i \end{bmatrix}. \quad (\text{C.2.1})$$

The q -expansions of $\eta(\tau)^{-12}$ and $\bar{\eta}(\bar{\tau})^{-24}$ are

$$\begin{aligned} \frac{1}{\eta(\tau)^{12}} &= \frac{1}{\sqrt{q}} + \mathcal{O}(\sqrt{q}), \\ \frac{1}{\bar{\eta}(\bar{\tau})^{24}} &= \frac{1}{\bar{q}} + 24 + \mathcal{O}(\bar{q}). \end{aligned} \quad (\text{C.2.2})$$

The source of the exponential suppression of the one loop cosmological constant is then that, in the sectors where $\ell = \ell_1 + \ell_2$ is odd (so that the contributions does not just vanish by supersymmetry), the q -expansion of the partition function is found to be missing the constant term due to the Bose-Fermi degeneracy among the massless states:

$$\begin{aligned} \mathcal{Z} &\propto \frac{1}{\eta(\tau)^{12} \bar{\eta}(\bar{\tau})^{24}} (128\sqrt{q} - 3072\bar{q}\sqrt{q} + \dots) \\ &= \frac{128}{\bar{q}} + 0 + \mathcal{O}((q\bar{q})^{1/2}). \end{aligned} \quad (\text{C.2.3})$$

Appendix D

The two-loop cosmological constant

D.1 The hyperelliptic formalism

In the hyperelliptic formalism, a genus two surface is represented as a two sheet covering of the complex plane described by the equation

$$y^2(z) = \prod_{i=1}^6 (z - a_i), \quad (\text{D.1.1})$$

where the complex numbers a_i are the 6 branch points. Three of these represent the moduli of the surface while the other three can be fixed arbitrarily. In this formalism the even spin structures are equivalent to ten different splittings of the six branch points into two non-ordered sets $\{A_1, A_2, A_3\}$, $\{B_1, B_2, B_3\}$. For each even spin structure one can define a spin structure dependent quantity Q_δ as

$$Q_\delta = \prod_{i < j} (A_i - A_j)(B_i - B_j), \quad (\text{D.1.2})$$

which is proportional to the usual ϑ -functions $\vartheta_\delta^4(0)$ through the Thomae formula, which will be shown explicitly in the following section. In the hyperelliptic representation the Szegő kernel is then given by

$$S_\delta(z, w) = \frac{1}{z - w} \frac{u(z) + u(w)}{2\sqrt{u(z)u(w)}}, \quad (\text{D.1.3})$$

$$u(z) \equiv \sqrt{\frac{r_A(z)}{r_B(z)}} = \prod_{i=1}^3 \left(\frac{z - A_i}{z - B_i} \right)^{1/2}, \quad (\text{D.1.4})$$

where we define

$$\begin{aligned} r_A(x) &= (x - A_1)(x - A_2)(x - A_3), \\ r_B(x) &= (x - B_1)(x - B_2)(x - B_3). \end{aligned} \quad (\text{D.1.5})$$

In split gauge,

$$[r_A(q_1)r_B(q_2)]^{\frac{1}{2}} + [r_A(q_2)r_B(q_1)]^{\frac{1}{2}} = 0, \quad (\text{D.1.6})$$

and so $u(q_2) = -u(q_1)$. For future reference we also define

$$S_n(x) = \sum_{i=1}^3 \left[\frac{1}{(x - A_i)^n} - \frac{1}{(x - B_i)^n} \right]. \quad (\text{D.1.7})$$

D.2 The two-loop cosmological constant in non-SUSY theories

D.2.1 General result in the ϑ -function formalism

The untwisted sector contribution to the cosmological constant for the 4D $\mathcal{N} = 0$ theory in the hyperelliptic language is given by [142, 143]

$$\Lambda_{2-loop} = \int_{\mathcal{F}_2} \frac{d\mu(m_a)}{(\det \text{Im } \Omega)^3} \sum_{\{\alpha^i, \beta^i\}} \Gamma_{2,2}^{(2)} \tilde{C} \begin{bmatrix} \alpha \\ \beta \end{bmatrix} \bar{L}_{S'(\bar{\phi})} R_{S'(\eta)}, \quad (\text{D.2.1})$$

where the measure $d\mu(m_a)$ can be written

$$d\mu(m_a) = \frac{\prod_{r=1}^6 d^2 a_r}{dV \prod_{k < l}^6 |a_{kl}|^2} = d^3 \Omega_{IJ} |\det K|^6. \quad (\text{D.2.2})$$

In the above, $d^3 \Omega_{IJ} = d^2 \tau_{11} d^2 \tau_{12} d^2 \tau_{22}$, and the elements of the matrix K are given by

$$K_{ij} = \oint_{A_i} \frac{x^{j-1} dx}{y(x)}. \quad (\text{D.2.3})$$

The contributions $\bar{L}_{S'(\bar{\phi})}$ and $R_{S'(\eta)}$ are expressed in terms of chiral determi-

nants, which in the hyperelliptic representation are given by [142]

$$\det \bar{\partial}_{1/2} = \prod_{k<l=1}^6 (a_{kl})^{-1/8} \left(\prod_{k<l=1}^3 A_{kl} B_{kl} \right)^{1/4}, \quad (\text{D.2.4})$$

$$\det \bar{\partial}_1 = \det K \prod_{k<l=1}^6 (a_{kl})^{1/4}, \quad (\text{D.2.5})$$

$$\det \bar{\partial}_{3/2} = \prod_{k<l=1}^6 (a_{kl})^{3/8} \left(\prod_{k<l=1}^3 A_{kl} B_{kl} \right)^{1/4}, \quad (\text{D.2.6})$$

$$\det \bar{\partial}_2 = \prod_{k<l=1}^6 (a_{kl})^{5/4}, \quad (\text{D.2.7})$$

where for example $A_{kl} = A_k - A_l$, so the terms in brackets in Equation D.2.4 and Equation D.2.6 are equal to the right hand side of Equation D.1.2. The expressions for $\bar{L}_{S'(\tilde{\phi})}$ and $R_{S'(\eta)}$ are

$$\begin{aligned} \bar{L}_{S'(\tilde{\phi})} &= (\det \bar{\partial}_1)^{-3} (\det \bar{\partial}_2) \prod_{\tilde{\phi}} (\det \bar{\partial}_{1/2})_{S'(\tilde{\phi})}^{1/2} \\ &= (\det \bar{K})^{-3} \prod_{k<l=1}^6 (\bar{a}_{kl})^{-2} \prod_{\tilde{\phi} \in F'_L} \bar{Q}_{S'(\tilde{\phi})}^{1/8}, \end{aligned} \quad (\text{D.2.8})$$

$$\begin{aligned} R_{S'(\eta)} &= \frac{1}{\det \psi_I(q_J)} \int \prod_{\alpha=1}^2 d\zeta^\alpha (\det \bar{\partial}_1)^{-3} (\det \bar{\partial}_2) (\det \bar{\partial}_{3/2})_{S(\beta)}^{-1} \left(1 + \sum_{i=1}^6 \mathcal{X}_i \right) \\ &\quad \times \prod_{\eta} (\det \bar{\partial}_{1/2})_{S'(\eta)}^{1/2} \\ &= \frac{1}{\det \psi_I(q_J)} \int \prod_{\alpha=1}^2 d\zeta^\alpha (\det K)^{-3} \prod_{k<l=1}^6 (a_{kl})^{-1} \left(1 + \sum_{i=1}^6 \mathcal{X}_i \right) \prod_{\eta \in F'_R} Q_{S'(\eta)}^{1/8}, \end{aligned} \quad (\text{D.2.9})$$

where the sets F'_L and F'_R denote all the transverse left and right moving fermions respectively, and $\psi_I(q_J)$ are the holomorphic 3/2-differentials for $I = 1, 2$. The points q_1 and q_2 are arbitrary points on the super Riemann surface representing the superghost insertion points. The final result is independent of the particular choice of points so we may work in the split gauge where $S_\delta(q_1, q_2) = 0$. With this choice, one finds that

$$\mathcal{X}_1 + \mathcal{X}_6 = \mathcal{X}_2 = \mathcal{X}_3 = \mathcal{X}_4 = 0, \quad (\text{D.2.10})$$

while

$$\begin{aligned} \mathcal{X}_5 &= \frac{\zeta^1 \zeta^2}{16\pi^2} \sum_a [S_\delta(p_a q_1) \partial_{p_a} S_\delta(p_a, q_2) - S_\delta \partial_{p_a} S_\delta(p_a, q_1)] \varpi_a(q_1, q_2) \\ &= \frac{\zeta^1 \zeta^2}{64i\pi^2} \sum_a \left[\frac{(q_1 - q_2) [u(p_a)^2 - u(q_1)^2]}{(p_a - q_1)^2 (p_a - q_2)^2 u(p_a) u(q_1)} + \frac{2S_1(p_a)}{(p_a - q_1)(p_a - q_2)} \right] \varpi_a(q_1, q_2) \end{aligned} \quad (\text{D.2.11})$$

where

$$\begin{aligned} \varpi_1(q_1, q_2) &= \frac{\omega_{\nu_2}(q_1)\omega_{\nu_3}(q_2) + \omega_{\nu_2}(q_2)\omega_{\nu_3}(q_1)}{2\omega_{\nu_2}(p_1)\omega_{\nu_3}(p_1)}, \\ \varpi_2(q_1, q_2) &= \frac{\omega_{\nu_1}(q_1)\omega_{\nu_3}(q_2) + \omega_{\nu_1}(q_2)\omega_{\nu_3}(q_1)}{2\omega_{\nu_1}(p_2)\omega_{\nu_3}(p_2)}, \\ \varpi_3(q_1, q_2) &= \frac{\omega_{\nu_1}(q_1)\omega_{\nu_2}(q_2) + \omega_{\nu_1}(q_2)\omega_{\nu_2}(q_1)}{2\omega_{\nu_1}(p_3)\omega_{\nu_2}(p_3)}, \end{aligned} \quad (\text{D.2.12})$$

where

$$\omega_{\nu_i}(z) = \mathcal{N}_{\nu_i}(x - u_i) \frac{dx}{s(x)}. \quad (\text{D.2.13})$$

The holomorphic 3/2 differentials are given by

$$\psi_A = r_A(x)^{\frac{1}{2}} \left(\frac{dx}{s(x)} \right)^{3/2}, \quad \psi_B = r_B(x)^{\frac{1}{2}} \left(\frac{dx}{s(x)} \right)^{3/2}, \quad (\text{D.2.14})$$

and so in the split gauge

$$\det \psi_I(q_J) = 2 \frac{r_A(q_1)^{\frac{1}{2}} r_B(q_2)^{\frac{1}{2}}}{s(q_1)^{\frac{3}{2}} s(q_2)^{\frac{3}{2}}} = \frac{-2i}{s(q_1) s(q_2)}. \quad (\text{D.2.15})$$

Collecting everything together then, the cosmological constant can be written as

$$\begin{aligned} \Lambda_{2-loop} &= \int_{\mathcal{F}_2} \frac{d^3 \Omega_{IJ}}{(\det \text{Im } \Omega)^3} \int \prod_{\alpha=1}^2 d\zeta^\alpha \sum_{\{\alpha^i, \beta^i\}} \Gamma_{2,2}^{(2)} \tilde{C} \begin{bmatrix} \alpha \\ \beta \end{bmatrix} \prod_{k<l=1}^6 (a_{kl})^{-1} (\bar{a}_{kl})^{-2} \\ &\times \frac{\mathcal{X}_5}{\det \psi_I(q_J)} \prod_{\eta \in F'_R} Q_{S'(\eta)}^{1/8} \prod_{\tilde{\phi} \in F'_L} \bar{Q}_{S'(\tilde{\phi})}^{1/8}. \end{aligned} \quad (\text{D.2.16})$$

Now, we would like to express the cosmological constant entirely in the ϑ -function representation rather than the hyperelliptic representation. One may do this using the aforementioned Thomae formula,

$$\vartheta_\delta^4(0) = \pm \det^2 K Q_\delta. \quad (\text{D.2.17})$$

This gives on the left-moving side

$$\prod_{k<l=1}^6 (\bar{a}_{kl})^{-2} = \prod_{\delta \text{ even}} \bar{Q}_\delta^{-1/2} = (\det \bar{K})^{10} \prod_{\delta \text{ even}} \bar{\vartheta}[\delta]^{-2}(0, \bar{\Omega}) = (\det \bar{K})^{10} \bar{\Psi}_{10}^{-1}(\bar{\Omega}), \quad (\text{D.2.18})$$

where $\Psi_{10}(\Omega)$ is the weight 10 Igusa cusp form. We also find on the right-moving side

$$\prod_{k<l=1}^6 (a_{kl})^{-1} \int \prod_{\alpha=1}^2 d\zeta^\alpha \frac{\mathcal{X}_5}{\det \psi_I(q_J)} = \dots = \frac{\Xi[\delta](\Omega)}{\Psi_{10}(\Omega)}, \quad (\text{D.2.19})$$

where

$$\Xi_6[\delta](\Omega) \equiv \sum_{1 \leq i < j \leq 3} \langle \nu_i | \nu_j \rangle \prod_{k=4,5,6} \vartheta[\nu_i + \nu_j + \nu_k]^4(0, \Omega). \quad (\text{D.2.20})$$

The even spin structure δ in the definition of $\Xi_6[\delta]$ is written as a sum of three distinct odd spin structures, $\delta = \nu_1 + \nu_2 + \nu_3$. We arrive at the two-loop cosmological constant expressed purely in the ϑ -function formalism:

$$\Lambda_{2-loop} = \int_{\mathcal{F}_2} \frac{d^3 \Omega_{IJ}}{(\det \text{Im } \Omega)^3} \sum_{\{\alpha^i, \beta^i\}} \frac{\Gamma_{2,2}^{(2)}}{|\Psi_{10}|^2} \tilde{C} \begin{bmatrix} \alpha \\ \beta \end{bmatrix} \Xi_6 \begin{bmatrix} \alpha^1 s & \alpha^2 s \\ \beta^1 s & \beta^2 s \end{bmatrix} \prod_{\eta \in F'_R} \vartheta_{S'(\eta)}^{1/2} \prod_{\tilde{\phi} \in F'_L} \bar{\vartheta}_{S'(\tilde{\phi})}^{1/2}. \quad (\text{D.2.21})$$

Appendix E

Evaluation of the massless contribution to the two-loop cosmological constant

We may evaluate the massless contribution to the cosmological constant which, after integrating over the real parts of the three odd moduli, is proportional to

$$\Lambda^0 \propto \int \frac{dL_1 dL_2 dL_3}{\Delta^4} T_2^2 \sum_{l_i^r} \exp \left\{ - \frac{\pi T_2}{\Delta U_2} \left[(l_1^1)^2 L_3 + (l_1^2)^2 L_1 + (l_1^1 - l_1^2)^2 L_2 \right] - \frac{\pi T_2 U_2}{\Delta} \left[(l_2^1)^2 L_3 + (l_2^2)^2 L_1 + (l_2^1 - l_2^2)^2 L_2 \right] \right\}, \quad (\text{E.1})$$

where $\Delta \equiv \det \text{Im } \Omega = L_1 L_2 + L_1 L_3 + L_2 L_3$. To compute this integral, we redefine the integration variables so that the integral takes the form of a one-loop integral together with an additional integral over some volume. To do so, we let

$$\tau_1 = \frac{L_2}{L_1 + L_2}, \quad \tau_2 = \frac{\sqrt{\Delta}}{L_1 + L_2}, \quad V = \frac{1}{\sqrt{\Delta}}, \quad (\text{E.2})$$

so we can take our expression for Λ^0 and substitute in

$$L_1 = \frac{1 - \tau_1}{V \tau_2}, \quad L_2 = \frac{\tau_1}{V \tau_2}, \quad L_3 = \frac{|\tau|^2 - \tau_1}{V \tau_2}. \quad (\text{E.3})$$

The measure of integration can hence be written

$$dL_1 dL_2 dL_3 = 2 \frac{dV d^2\tau}{V^4 \tau_2^2}. \quad (\text{E.4})$$

By taking the two-loop fundamental domain into consideration we find that the integration over V must be taken over the range $0 \leq V < 1$ while the integration over τ is taken over the usual one-loop fundamental domain with the modification that τ_2 has an upper limit of $1/V$. So we can define the integration domain for τ as

$$\mathcal{F}' = \left\{ \tau \in \mathbb{H} : |\tau|^2 > 1, |\tau_1| < \frac{1}{2}, \tau_2 < \frac{1}{V} \right\}. \quad (\text{E.5})$$

So overall the massless contribution to the cosmological constant is given by

$$\Lambda^0 \propto \int_0^1 dV V^4 \int_{\mathcal{F}'} \frac{d^2\tau}{\tau_2^2} T_2^2 \sum_{l_i^I} \exp \left\{ -\frac{\pi V}{\tau_2} \left[\frac{T_2}{U_2} |l_1^1 \tau - l_1^2|^2 + T_2 U_2 |l_2^1 \tau - l_2^2|^2 \right] \right\} \quad (\text{E.6})$$

We can now proceed to compute this integral using the method of orbits. Before doing so, recall that the only non-vanishing contributions can arise when either $l_1^1 + l_2^2 = \text{odd}$ or $l_2^1 + l_1^2 = \text{odd}$. Therefore, there is no contribution coming from the zero orbit where all $l_i^I = 0$.

The contribution from the degenerate orbits is

$$\frac{1}{2\pi^3 T_2} \sum'_{m+n=\text{odd}} \frac{U_2^3}{|m + nU|^6}, \quad (\text{E.7})$$

while contributions from non-degenerate orbits are exponentially suppressed for large T_2 .

Bibliography

- [1] E. Kiritsis. *String theory in a nutshell*. 2007.
- [2] K. Becker, M. Becker, and J. H. Schwarz. *String theory and M-theory: A modern introduction*. Cambridge University Press, 2006.
- [3] D. Bailin and A. Love. *Supersymmetric gauge field theory and string theory*. 1994.
- [4] M. Dine. *Supersymmetry and string theory: Beyond the standard model*. 2007. ISBN: 9781107048386.
- [5] J. Polchinski. *String theory. Vol. 1: An introduction to the bosonic string*. Cambridge University Press, 2007.
- [6] J. Polchinski. *String theory. Vol. 2: Superstring theory and beyond*. Cambridge University Press, 2007.
- [7] S. Abel, K. R. Dienes, and E. Mavroudi. “Towards a nonsupersymmetric string phenomenology”. *Phys. Rev.* D91.12 (2015), p. 126014. arXiv: 1502.03087 [hep-th].
- [8] G. Lopes Cardoso, D. Lust, and T. Mohaupt. “Moduli spaces and target space duality symmetries in (0,2) Z(N) orbifold theories with continuous Wilson lines”. *Nucl. Phys.* B432 (1994), pp. 68–108. arXiv: hep-th/9405002 [hep-th].
- [9] G. Lopes Cardoso, D. Lust, and T. Mohaupt. “Threshold corrections and symmetry enhancement in string compactifications”. *Nucl. Phys.* B450 (1995), pp. 115–173. arXiv: hep-th/9412209 [hep-th].

- [10] I. Antoniadis, E. Gava, K. S. Narain, and T. R. Taylor. “Superstring threshold corrections to Yukawa couplings”. *Nucl. Phys.* B407 (1993), pp. 706–724. arXiv: hep-th/9212045 [hep-th].
- [11] I. Antoniadis, E. Gava, K. S. Narain, and T. R. Taylor. “Effective mu term in superstring theory”. *Nucl. Phys.* B432 (1994), pp. 187–204. arXiv: hep-th/9405024 [hep-th].
- [12] A. Brignole and F. Zwirner. “Supersymmetry and $SU(2) \times U(1)$ breaking with naturally vanishing vacuum energy”. *Phys. Lett.* B342 (1995), pp. 117–124. arXiv: hep-th/9409099 [hep-th].
- [13] A. Brignole, L. E. Ibanez, C. Munoz, and C. Scheich. “Some issues in soft SUSY breaking terms from dilaton / moduli sectors”. *Z. Phys.* C74 (1997), pp. 157–170. arXiv: hep-ph/9508258 [hep-ph].
- [14] G. R. Dvali and S. Pokorski. “The Role of the anomalous $U(1)$ -A for the solution of the doublet - triplet splitting problem”. *Phys. Rev. Lett.* 78 (1997), pp. 807–810. arXiv: hep-ph/9610431 [hep-ph].
- [15] Z. G. Berezhiani and G. R. Dvali. “Possible solution of the hierarchy problem in supersymmetrical grand unification theories”. *Bull. Lebedev Phys. Inst.* 5 (1989). [Kratk. Soobshch. Fiz.5,42(1989)], pp. 55–59.
- [16] A. Hebecker, A. K. Knochel, and T. Weigand. “A Shift Symmetry in the Higgs Sector: Experimental Hints and Stringy Realizations”. *JHEP* 06 (2012), p. 093. arXiv: 1204.2551 [hep-th].
- [17] A. Hebecker, A. K. Knochel, and T. Weigand. “The Higgs mass from a String-Theoretic Perspective”. *Nucl. Phys.* B874 (2013), pp. 1–35. arXiv: 1304.2767 [hep-th].
- [18] H. Luo and F. Zwirner. “Geometrical hierarchies in classical supergravity”. *Phys. Rev. Lett.* 113 (2014), p. 021801. arXiv: 1403.4942 [hep-th].
- [19] L. E. Ibanez, F. Marchesano, and I. Valenzuela. “Higgs-otic Inflation and String Theory”. *JHEP* 01 (2015), p. 128. arXiv: 1411.5380 [hep-th].

- [20] M. Berg, M. Haack, and B. Kors. “String loop corrections to Kahler potentials in orientifolds”. *JHEP* 11 (2005), p. 030. arXiv: [hep-th/0508043](#) [[hep-th](#)].
- [21] K. Forger and S. Stieberger. “String amplitudes and $N=2$, $d = 4$ prepotential in heterotic $K3 \times T^{**2}$ compactifications”. *Nucl. Phys.* B514 (1998), pp. 135–160. arXiv: [hep-th/9709004](#) [[hep-th](#)].
- [22] B. de Wit, V. Kaplunovsky, J. Louis, and D. Lust. “Perturbative couplings of vector multiplets in $N=2$ heterotic string vacua”. *Nucl. Phys.* B451 (1995), pp. 53–95. arXiv: [hep-th/9504006](#) [[hep-th](#)].
- [23] E. Kiritsis, C. Kounnas, P. M. Petropoulos, and J. Rizos. “On the heterotic effective action at one loop gauge couplings and the gravitational sector”. *5th Hellenic School and Workshops on Elementary Particle Physics (CORFU 1995) Corfu, Greece, September 3-24, 1995*. 1996. arXiv: [hep-th/9605011](#) [[hep-th](#)].
- [24] E. Kiritsis and N. A. Obers. “Heterotic type I duality in $D < 10$ -dimensions, threshold corrections and D instantons”. *JHEP* 10 (1997), p. 004. arXiv: [hep-th/9709058](#) [[hep-th](#)].
- [25] I. Antoniadis, E. Gava, and K. S. Narain. “Moduli corrections to gravitational couplings from string loops”. *Phys. Lett.* B283 (1992), pp. 209–212. arXiv: [hep-th/9203071](#) [[hep-th](#)].
- [26] L. J. Dixon, V. Kaplunovsky, and J. Louis. “Moduli dependence of string loop corrections to gauge coupling constants”. *Nucl. Phys.* B355 (1991), pp. 649–688.
- [27] P. G. Camara and E. Dudas. “Multi-instanton and string loop corrections in toroidal orbifold models”. *JHEP* 08 (2008), p. 069. arXiv: [0806.3102](#) [[hep-th](#)].
- [28] C. Bachas, C. Fabre, E. Kiritsis, N. A. Obers, and P. Vanhove. “Heterotic / type I duality and D -brane instantons”. *Nucl. Phys.* B509 (1998), pp. 33–52. arXiv: [hep-th/9707126](#) [[hep-th](#)].

- [29] J. A. Harvey and G. W. Moore. “Algebras, BPS states, and strings”. *Nucl. Phys.* B463 (1996), pp. 315–368. arXiv: hep-th/9510182 [hep-th].
- [30] K. Foerger and S. Stieberger. “Higher derivative couplings and heterotic type I duality in eight-dimensions”. *Nucl. Phys.* B559 (1999), pp. 277–300. arXiv: hep-th/9901020 [hep-th].
- [31] N. Vanegas-Arbelaez. “Regularization of automorphic functions of manifolds with special Kahler geometry” (1999). arXiv: hep-th/9906028 [hep-th].
- [32] V. Kaplunovsky and J. Louis. “On Gauge couplings in string theory”. *Nucl. Phys.* B444 (1995), pp. 191–244. arXiv: hep-th/9502077 [hep-th].
- [33] M. Arends, A. Hebecker, K. Heimpel, S. C. Kraus, D. Lust, C. Mayrhofer, C. Schick, and T. Weigand. “D7-Brane Moduli Space in Axion Monodromy and Fluxbrane Inflation”. *Fortsch. Phys.* 62 (2014), pp. 647–702. arXiv: 1405.0283 [hep-th].
- [34] G. Dvali and A. Vilenkin. “Cosmic attractors and gauge hierarchy”. *Phys. Rev.* D70 (2004), p. 063501. arXiv: hep-th/0304043 [hep-th].
- [35] G. Dvali. “Large hierarchies from attractor vacua”. *Phys. Rev.* D74 (2006), p. 025018. arXiv: hep-th/0410286 [hep-th].
- [36] P. W. Graham, D. E. Kaplan, and S. Rajendran. “Cosmological Relaxation of the Electroweak Scale”. *Phys. Rev. Lett.* 115.22 (2015), p. 221801. arXiv: 1504.07551 [hep-ph].
- [37] A. Kobakhidze. “Quantum relaxation of the Higgs mass”. *Eur. Phys. J.* C75.8 (2015), p. 384. arXiv: 1506.04840 [hep-ph].
- [38] J. R. Espinosa, C. Grojean, G. Panico, A. Pomarol, O. PujolÀàs, and G. Servant. “Cosmological Higgs-Axion Interplay for a Naturally Small Electroweak Scale”. *Phys. Rev. Lett.* 115.25 (2015), p. 251803. arXiv: 1506.09217 [hep-ph].

- [39] E. Hardy. “Electroweak relaxation from finite temperature”. *JHEP* 11 (2015), p. 077. arXiv: 1507.07525 [hep-ph].
- [40] S. P. Patil and P. Schwaller. “Relaxing the Electroweak Scale: the Role of Broken dS Symmetry”. *JHEP* 02 (2016), p. 077. arXiv: 1507.08649 [hep-ph].
- [41] O. Antipin and M. Redi. “The Half-composite Two Higgs Doublet Model and the Relaxion”. *JHEP* 12 (2015), p. 031. arXiv: 1508.01112 [hep-ph].
- [42] J. Jaeckel, V. M. Mehta, and L. T. Witkowski. “Musings on cosmological relaxation and the hierarchy problem”. *Phys. Rev. D* 93.6 (2016), p. 063522. arXiv: 1508.03321 [hep-ph].
- [43] R. S. Gupta, Z. Komargodski, G. Perez, and L. Ubaldi. “Is the Relaxion an Axion?” *JHEP* 02 (2016), p. 166. arXiv: 1509.00047 [hep-ph].
- [44] B. Batell, G. F. Giudice, and M. McCullough. “Natural Heavy Supersymmetry”. *JHEP* 12 (2015), p. 162. arXiv: 1509.00834 [hep-ph].
- [45] K. Choi and S. H. Im. “Realizing the relaxion from multiple axions and its UV completion with high scale supersymmetry”. *JHEP* 01 (2016), p. 149. arXiv: 1511.00132 [hep-ph].
- [46] D. E. Kaplan and R. Rattazzi. “Large field excursions and approximate discrete symmetries from a clockwork axion”. *Phys. Rev. D* 93.8 (2016), p. 085007. arXiv: 1511.01827 [hep-ph].
- [47] R. Kappl, H. P. Nilles, and M. W. Winkler. “Modulated Natural Inflation”. *Phys. Lett. B* 753 (2016), pp. 653–659. arXiv: 1511.05560 [hep-th].
- [48] L. E. Ibanez, M. Montero, A. Uranga, and I. Valenzuela. “Relaxion Monodromy and the Weak Gravity Conjecture”. *JHEP* 04 (2016), p. 020. arXiv: 1512.00025 [hep-th].
- [49] K. Choi and H. Kim. “Aligned natural inflation with modulations”. *Phys. Lett. B* 759 (2016), pp. 520–527. arXiv: 1511.07201 [hep-th].

- [50] S. Kachru and E. Silverstein. “On vanishing two loop cosmological constants in nonsupersymmetric strings”. *JHEP* 01 (1999), p. 004. arXiv: hep-th/9810129 [hep-th].
- [51] S. Kachru, J. Kumar, and E. Silverstein. “Vacuum energy cancellation in a nonsupersymmetric string”. *Phys. Rev. D* 59 (1999), p. 106004. arXiv: hep-th/9807076 [hep-th].
- [52] S. Abel. “A dynamical mechanism for large volumes with consistent couplings”. *JHEP* 11 (2016), p. 085. arXiv: 1609.01311 [hep-th].
- [53] I. Jack and D. R. T. Jones. “Naturalness without supersymmetry?” *Phys. Lett. B* 234 (1990), pp. 321–323.
- [54] M. S. Al-sarhi, I. Jack, and D. R. T. Jones. “Quadratic divergences in gauge theories”. *Z. Phys. C* 55 (1992), pp. 283–288.
- [55] M. Chaichian, R. Gonzalez Felipe, and K. Huitu. “On quadratic divergences and the Higgs mass”. *Phys. Lett. B* 363 (1995), pp. 101–105. arXiv: hep-ph/9509223 [hep-ph].
- [56] I. Masina and M. Quiros. “On the Veltman Condition, the Hierarchy Problem and High-Scale Supersymmetry”. *Phys. Rev. D* 88 (2013), p. 093003. arXiv: 1308.1242 [hep-ph].
- [57] M. J. G. Veltman. “The Infrared - Ultraviolet Connection”. *Acta Phys. Polon.* B12 (1981), p. 437.
- [58] D. Kutasov and N. Seiberg. “Number of degrees of freedom, density of states and tachyons in string theory and CFT”. *Nucl. Phys. B* 358 (1991), pp. 600–618.
- [59] K. R. Dienes, M. Moshe, and R. C. Myers. “String theory, misaligned supersymmetry, and the supertrace constraints”. *Phys. Rev. Lett.* 74 (1995), pp. 4767–4770. arXiv: hep-th/9503055 [hep-th].

- [60] K. R. Dienes, M. Moshe, and R. C. Myers. “Supertraces in string theory”. *Future perspectives in string theory. Proceedings, Conference, Strings’95, Los Angeles, USA, March 13-18, 1995*. 1995, pp. 178–180. arXiv: hep-th/9506001 [hep-th].
- [61] S. Abel and K. Dienes. *in preparation*.
- [62] J. Scherk and J. H. Schwarz. “Spontaneous Breaking of Supersymmetry Through Dimensional Reduction”. *Phys. Lett.* B82 (1979), pp. 60–64.
- [63] C. Kounnas and B. Rostand. “Coordinate Dependent Compactifications and Discrete Symmetries”. *Nucl. Phys.* B341 (1990), pp. 641–665.
- [64] S. Ferrara, C. Kounnas, and M. Porrati. “Superstring Solutions With Spontaneously Broken Four-dimensional Supersymmetry”. *Nucl. Phys.* B304 (1988), pp. 500–512.
- [65] S. Ferrara, C. Kounnas, and M. Porrati. “ $N = 1$ Superstrings With Spontaneously Broken Symmetries”. *Phys. Lett.* B206 (1988), pp. 25–31.
- [66] S. Ferrara, C. Kounnas, M. Porrati, and F. Zwirner. “Superstrings with Spontaneously Broken Supersymmetry and their Effective Theories”. *Nucl. Phys.* B318 (1989), pp. 75–105.
- [67] H. Itoyama and T. R. Taylor. “Supersymmetry Restoration in the Compactified $O(16) \times O(16)$ -prime Heterotic String Theory”. *Phys. Lett.* B186 (1987), pp. 129–133.
- [68] H. Itoyama and T. R. Taylor. “Small Cosmological Constant in String Models”. *International Europhysics Conference on High-energy Physics Uppsala, Sweden, June 25-July 1, 1987*. 1987.
- [69] K. R. Dienes. “Modular invariance, finiteness, and misaligned supersymmetry: New constraints on the numbers of physical string states”. *Nucl. Phys.* B429 (1994), pp. 533–588. arXiv: hep-th/9402006 [hep-th].

- [70] K. R. Dienes. “How strings make do without supersymmetry: An Introduction to misaligned supersymmetry”. *PASCOS '94: Proceedings, 4th International Symposium on Particles, Strings and Cosmology, Syracuse, New York, USA, May 19-24, 1994*. 1994, pp. 0234–243. arXiv: hep-th/9409114 [hep-th].
- [71] K. R. Dienes. “Space-time properties of (1,0) string vacua”. *Future perspectives in string theory. Proceedings, Conference, Strings'95, Los Angeles, USA, March 13-18, 1995*. 1995, pp. 173–177. arXiv: hep-th/9505194 [hep-th].
- [72] K. R. Dienes. “Solving the hierarchy problem without supersymmetry or extra dimensions: An Alternative approach”. *Nucl. Phys.* B611 (2001), pp. 146–178. arXiv: hep-ph/0104274 [hep-ph].
- [73] R. Rohm. “Spontaneous Supersymmetry Breaking in Supersymmetric String Theories”. *Nucl. Phys.* B237 (1984), pp. 553–572.
- [74] V. P. Nair, A. D. Shapere, A. Strominger, and F. Wilczek. “Compactification of the Twisted Heterotic String”. *Nucl. Phys.* B287 (1987), pp. 402–418.
- [75] P. H. Ginsparg and C. Vafa. “Toroidal Compactification of Nonsupersymmetric Heterotic Strings”. *Nucl. Phys.* B289 (1987), p. 414.
- [76] G. W. Moore. “Atkin-Lehner Symmetry”. *Nucl. Phys.* B293 (1987). [Erratum: *Nucl. Phys.* B299,847(1988)], p. 139.
- [77] J. Balog and M. P. Tuite. “The Failure of Atkin-lehner Symmetry for Lattice Compactified Strings”. *Nucl. Phys.* B319 (1989), pp. 387–414.
- [78] K. R. Dienes. “Generalized Atkin-Lehner Symmetry”. *Phys. Rev.* D42 (1990), pp. 2004–2021.
- [79] K. R. Dienes. “New string partition functions with vanishing cosmological constant”. *Phys. Rev. Lett.* 65 (1990), pp. 1979–1982.

- [80] J. A. Harvey. “String duality and nonsupersymmetric strings”. *Phys. Rev.* D59 (1999), p. 026002. arXiv: hep-th/9807213 [hep-th].
- [81] S. Kachru and E. Silverstein. “Selfdual nonsupersymmetric type II string compactifications”. *JHEP* 11 (1998), p. 001. arXiv: hep-th/9808056 [hep-th].
- [82] R. Blumenhagen and L. Gorlich. “Orientifolds of nonsupersymmetric asymmetric orbifolds”. *Nucl. Phys.* B551 (1999), pp. 601–616. arXiv: hep-th/9812158 [hep-th].
- [83] C. Angelantonj, I. Antoniadis, and K. Forger. “Nonsupersymmetric type I strings with zero vacuum energy”. *Nucl. Phys.* B555 (1999), pp. 116–134. arXiv: hep-th/9904092 [hep-th].
- [84] M. R. Gaberdiel and A. Sen. “Nonsupersymmetric D-brane configurations with Bose-Fermi degenerate open string spectrum”. *JHEP* 11 (1999), p. 008. arXiv: hep-th/9908060 [hep-th].
- [85] G. Shiu and S. H. H. Tye. “Bose-Fermi degeneracy and duality in nonsupersymmetric strings”. *Nucl. Phys.* B542 (1999), pp. 45–72. arXiv: hep-th/9808095 [hep-th].
- [86] R. Iengo and C.-J. Zhu. “Evidence for nonvanishing cosmological constant in nonSUSY superstring models”. *JHEP* 04 (2000), p. 028. arXiv: hep-th/9912074 [hep-th].
- [87] A. E. Faraggi and M. Tsulaia. “Interpolations Among NAHE-based Supersymmetric and Nonsupersymmetric String Vacua”. *Phys. Lett.* B683 (2010), pp. 314–320. arXiv: 0911.5125 [hep-th].
- [88] C. Angelantonj, M. Cardella, S. Elitzur, and E. Rabinovici. “Vacuum stability, string density of states and the Riemann zeta function”. *JHEP* 02 (2011), p. 024. arXiv: 1012.5091 [hep-th].
- [89] O. Bergman and M. R. Gaberdiel. “A Nonsupersymmetric open string theory and S duality”. *Nucl. Phys.* B499 (1997), pp. 183–204. arXiv: hep-th/9701137 [hep-th].

- [90] O. Bergman and M. R. Gaberdiel. “Dualities of type 0 strings”. *JHEP* 07 (1999), p. 022. arXiv: [hep-th/9906055](#) [[hep-th](#)].
- [91] R. Blumenhagen and A. Kumar. “A Note on orientifolds and dualities of type 0B string theory”. *Phys. Lett.* B464 (1999), pp. 46–52. arXiv: [hep-th/9906234](#) [[hep-th](#)].
- [92] J. D. Blum and K. R. Dienes. “Duality without supersymmetry: The Case of the $SO(16) \times SO(16)$ string”. *Phys. Lett.* B414 (1997), pp. 260–268. arXiv: [hep-th/9707148](#) [[hep-th](#)].
- [93] J. D. Blum and K. R. Dienes. “Strong / weak coupling duality relations for nonsupersymmetric string theories”. *Nucl. Phys.* B516 (1998), pp. 83–159. arXiv: [hep-th/9707160](#) [[hep-th](#)].
- [94] A. E. Faraggi and M. Tsulaia. “On the Low Energy Spectra of the Non-supersymmetric Heterotic String Theories”. *Eur. Phys. J.* C54 (2008), pp. 495–500. arXiv: [0706.1649](#) [[hep-th](#)].
- [95] K. R. Dienes. “Statistics on the heterotic landscape: Gauge groups and cosmological constants of four-dimensional heterotic strings”. *Phys. Rev.* D73 (2006), p. 106010. arXiv: [hep-th/0602286](#) [[hep-th](#)].
- [96] K. R. Dienes, M. Lennek, and M. Sharma. “Strings at Finite Temperature: Wilson Lines, Free Energies, and the Thermal Landscape”. *Phys. Rev.* D86 (2012), p. 066007. arXiv: [1205.5752](#) [[hep-th](#)].
- [97] E. Kiritsis and C. Kounnas. “Perturbative and nonperturbative partial supersymmetry breaking: $N = 4 \rightarrow N = 2 \rightarrow N = 1$ ”. *Nucl. Phys.* B503 (1997), pp. 117–156. arXiv: [hep-th/9703059](#) [[hep-th](#)].
- [98] E. Dudas and J. Mourad. “Brane solutions in strings with broken supersymmetry and dilaton tadpoles”. *Phys. Lett.* B486 (2000), pp. 172–178. arXiv: [hep-th/0004165](#) [[hep-th](#)].
- [99] C. A. Scrucca and M. Serone. “On string models with Scherk-Schwarz supersymmetry breaking”. *JHEP* 10 (2001), p. 017. arXiv: [hep-th/0107159](#) [[hep-th](#)].

- [100] M. Borunda, M. Serone, and M. Trapletti. “On the quantum stability of IIB orbifolds and orientifolds with Scherk-Schwarz SUSY breaking”. *Nucl. Phys. B* 653 (2003), pp. 85–108. arXiv: hep-th/0210075 [hep-th].
- [101] C. Angelantonj, M. Cardella, and N. Irges. “An Alternative for Moduli Stabilisation”. *Phys. Lett. B* 641 (2006), pp. 474–480. arXiv: hep-th/0608022 [hep-th].
- [102] D. Lust. “Compactification of the $O(16) \times O(16)$ Heterotic string theory”. *Phys. Lett. B* 178 (1986), p. 174.
- [103] W. Lerche, D. Lust, and A. N. Schellekens. “Ten-dimensional Heterotic Strings From Niemeier Lattices”. *Phys. Lett. B* 181 (1986), p. 71.
- [104] W. Lerche, D. Lust, and A. N. Schellekens. “Chiral Four-Dimensional Heterotic Strings from Selfdual Lattices”. *Nucl. Phys. B* 287 (1987), p. 477.
- [105] A. H. Chamseddine, J. P. Derendinger, and M. Quiros. “Nonsupersymmetric four-dimensional strings”. *Nucl. Phys. B* 311 (1988), pp. 140–170.
- [106] A. Font and A. Hernandez. “Nonsupersymmetric orbifolds”. *Nucl. Phys. B* 634 (2002), pp. 51–70. arXiv: hep-th/0202057 [hep-th].
- [107] M. Blaszczyk, S. Groot Nibbelink, O. Loukas, and S. Ramos-Sanchez. “Non-supersymmetric heterotic model building”. *JHEP* 10 (2014), p. 119. arXiv: 1407.6362 [hep-th].
- [108] C. Angelantonj, I. Florakis, and M. Tsulaia. “Universality of Gauge Thresholds in Non-Supersymmetric Heterotic Vacua”. *Phys. Lett. B* 736 (2014), pp. 365–370. arXiv: 1407.8023 [hep-th].
- [109] C. Angelantonj, I. Florakis, and M. Tsulaia. “Generalised universality of gauge thresholds in heterotic vacua with and without supersymmetry”. *Nucl. Phys. B* 900 (2015), pp. 170–197. arXiv: 1509.00027 [hep-th].
- [110] M. Blaszczyk, S. Groot Nibbelink, O. Loukas, and F. Ruehle. “Calabi-Yau compactifications of non-supersymmetric heterotic string theory”. *JHEP* 10 (2015), p. 166. arXiv: 1507.06147 [hep-th].

- [111] S. Groot Nibbelink and E. Parr. “Twisted superspace: Non-renormalization and fermionic symmetries in certain heterotic-string-inspired non-supersymmetric field theories”. *Phys. Rev. D* 94.4 (2016), p. 041704. arXiv: 1605.07470 [hep-ph].
- [112] A. E. Faraggi, C. Kounnas, and H. Partouche. “Large volume susy breaking with a solution to the decompactification problem”. *Nucl. Phys.* B899 (2015), pp. 328–374. arXiv: 1410.6147 [hep-th].
- [113] C. Kounnas and H. Partouche. “Stringy $N = 1$ super no-scale models”. *PoS PLANCK2015* (2015), p. 070. arXiv: 1511.02709 [hep-th].
- [114] H. Partouche. “Large volume supersymmetry breaking without decompactification problem”. *11th International Workshop on Lie Theory and Its Applications in Physics (LT-11) Varna, Bulgaria, June 15-21, 2015*. 2016. arXiv: 1601.04564 [hep-th].
- [115] C. Kounnas and H. Partouche. “Super no-scale models in string theory”. *Nucl. Phys.* B913 (2016), pp. 593–626. arXiv: 1607.01767 [hep-th].
- [116] C. Bachas. “A Way to break supersymmetry” (1995). arXiv: hep-th/9503030 [hep-th].
- [117] J. G. Russo and A. A. Tseytlin. “Magnetic flux tube models in superstring theory”. *Nucl. Phys.* B461 (1996), pp. 131–154. arXiv: hep-th/9508068 [hep-th].
- [118] A. A. Tseytlin. “Closed superstrings in magnetic field: Instabilities and supersymmetry breaking”. *Nucl. Phys. Proc. Suppl.* 49 (1996), pp. 338–349. arXiv: hep-th/9510041 [hep-th].
- [119] H.-P. Nilles and M. Spalinski. “Generalized string compactifications with spontaneously broken supersymmetry”. *Phys. Lett.* B392 (1997), pp. 67–76. arXiv: hep-th/9606145 [hep-th].
- [120] I. Shah and S. Thomas. “Finite soft terms in string compactifications with broken supersymmetry”. *Phys. Lett.* B409 (1997), pp. 188–198. arXiv: hep-th/9705182 [hep-th].

- [121] A. Sagnotti. “Some properties of open string theories”. *Supersymmetry and unification of fundamental interactions. Proceedings, International Workshop, SUSY 95, Palaiseau, France, May 15-19, 1995*. 1995, pp. 473–484. arXiv: [hep-th/9509080](#) [[hep-th](#)].
- [122] A. Sagnotti. “Surprises in open string perturbation theory”. *Nucl. Phys. Proc. Suppl.* 56B (1997), pp. 332–343. arXiv: [hep-th/9702093](#) [[hep-th](#)].
- [123] C. Angelantonj. “Nontachyonic open descendants of the 0B string theory”. *Phys. Lett.* B444 (1998), pp. 309–317. arXiv: [hep-th/9810214](#) [[hep-th](#)].
- [124] R. Blumenhagen, A. Font, and D. Lust. “Tachyon free orientifolds of type 0B strings in various dimensions”. *Nucl. Phys.* B558 (1999), pp. 159–177. arXiv: [hep-th/9904069](#) [[hep-th](#)].
- [125] S. Sugimoto. “Anomaly cancellations in type I D-9 - anti-D-9 system and the USp(32) string theory”. *Prog. Theor. Phys.* 102 (1999), pp. 685–699. arXiv: [hep-th/9905159](#) [[hep-th](#)].
- [126] G. Aldazabal, L. E. Ibanez, and F. Quevedo. “Standard - like models with broken supersymmetry from type I string vacua”. *JHEP* 01 (2000), p. 031. arXiv: [hep-th/9909172](#) [[hep-th](#)].
- [127] C. Angelantonj. “Nonsupersymmetric open string vacua”. *PoS trieste99* (1999), p. 015. arXiv: [hep-th/9907054](#) [[hep-th](#)].
- [128] K. Forger. “On nontachyonic $Z(N) \times Z(M)$ orientifolds of type 0B string theory”. *Phys. Lett.* B469 (1999), pp. 113–122. arXiv: [hep-th/9909010](#) [[hep-th](#)].
- [129] S. Moriyama. “USp(32) string as spontaneously supersymmetry broken theory”. *Phys. Lett.* B522 (2001), pp. 177–180. arXiv: [hep-th/0107203](#) [[hep-th](#)].
- [130] C. Angelantonj and I. Antoniadis. “Suppressing the cosmological constant in nonsupersymmetric type I strings”. *Nucl. Phys.* B676 (2004), pp. 129–148. arXiv: [hep-th/0307254](#) [[hep-th](#)].

- [131] E. Dudas and C. Timirgaziu. “Nontachyonic Scherk-Schwarz compactifications, cosmology and moduli stabilization”. *JHEP* 03 (2004), p. 060. arXiv: hep-th/0401201 [hep-th].
- [132] B. Gato-Rivera and A. N. Schellekens. “Non-supersymmetric Tachyon-free Type-II and Type-I Closed Strings from RCFT”. *Phys. Lett.* B656 (2007), pp. 127–131. arXiv: 0709.1426 [hep-th].
- [133] I. Antoniadis, C. Bachas, D. C. Lewellen, and T. N. Tomaras. “On Supersymmetry Breaking in Superstrings”. *Phys. Lett.* B207 (1988), pp. 441–446.
- [134] I. Antoniadis. “A Possible new dimension at a few TeV”. *Phys. Lett.* B246 (1990), pp. 377–384.
- [135] I. Antoniadis, C. Munoz, and M. Quiros. “Dynamical supersymmetry breaking with a large internal dimension”. *Nucl. Phys.* B397 (1993), pp. 515–538. arXiv: hep-ph/9211309 [hep-ph].
- [136] I. Antoniadis and M. Quiros. “Large radii and string unification”. *Phys. Lett.* B392 (1997), pp. 61–66. arXiv: hep-th/9609209 [hep-th].
- [137] K. Benakli. “Phenomenology of low quantum gravity scale models”. *Phys. Rev.* D60 (1999), p. 104002. arXiv: hep-ph/9809582 [hep-ph].
- [138] C. P. Bachas. “Scales of string theory”. *Class. Quant. Grav.* 17 (2000), pp. 951–959. arXiv: hep-th/0001093 [hep-th].
- [139] E. Dudas. “Theory and phenomenology of type I strings and M theory”. *Class. Quant. Grav.* 17 (2000), R41–R116. arXiv: hep-ph/0006190 [hep-ph].
- [140] E. P. Verlinde and H. L. Verlinde. “Multiloop Calculations in Covariant Superstring Theory”. *Phys. Lett.* B192 (1987), pp. 95–102.
- [141] D. Arnaudon, C. P. Bachas, V. Rivasseau, and P. Vegreville. “On the Vanishing of the Cosmological Constant in Four-dimensional Superstring Models”. *Phys. Lett.* B195 (1987), pp. 167–176.

- [142] E. Gava, R. Jengo, and G. Sotkov. “Modular Invariance and the Two Loop Vanishing of the Cosmological Constant”. *Phys. Lett.* B207 (1988), p. 283.
- [143] R. Jengo, G. M. Sotkov, and C.-J. Zhu. “Two Loop Vacuum Amplitude in Four-dimensional Heterotic String Models”. *Phys. Lett.* B211 (1988), p. 425.
- [144] G. W. Moore, J. Harris, P. Nelson, and I. Singer. “Modular Forms and the Cosmological Constant”. *Phys. Lett.* B178 (1986). [Erratum: *Phys. Lett.*B201,579(1988)], p. 167.
- [145] J. J. Atick, G. W. Moore, and A. Sen. “Some Global Issues in String Perturbation Theory”. *Nucl. Phys.* B308 (1988), pp. 1–101.
- [146] O. Lechtenfeld and A. Parkes. “On the Vanishing of the Genus - Two Superstring Vacuum Amplitude”. *Phys. Lett.* B202 (1988), pp. 75–80.
- [147] A. Parkes. “The Two Loop Superstring Vacuum Amplitude and Canonical Divisors”. *Phys. Lett.* B217 (1989), pp. 458–462.
- [148] T. Ortin. “The Genus two heterotic string cosmological constant”. *Nucl. Phys.* B387 (1992), pp. 280–314.
- [149] O. Lechtenfeld and A. Parkes. “On covariant multiloop superstring amplitudes”. *Nucl. Phys.* B332 (1990), pp. 39–82.
- [150] O. Lechtenfeld. “Factorization and Modular Invariance of Multiloop Superstring Amplitudes in the Unitary Gauge”. *Nucl. Phys.* B338 (1990), pp. 403–414.
- [151] E. D’Hoker and D. H. Phong. “Two loop superstrings. 1. Main formulas”. *Phys. Lett.* B529 (2002), pp. 241–255. arXiv: hep-th/0110247 [hep-th].
- [152] E. D’Hoker and D. H. Phong. “Two loop superstrings. 2. The Chiral measure on moduli space”. *Nucl. Phys.* B636 (2002), pp. 3–60. arXiv: hep-th/0110283 [hep-th].

- [153] E. D’Hoker and D. H. Phong. “Two loop superstrings. 3. Slice independence and absence of ambiguities”. *Nucl. Phys.* B636 (2002), pp. 61–79. arXiv: hep-th/0111016 [hep-th].
- [154] E. D’Hoker and D. H. Phong. “Two loop superstrings 4: The Cosmological constant and modular forms”. *Nucl. Phys.* B639 (2002), pp. 129–181. arXiv: hep-th/0111040 [hep-th].
- [155] K. Aoki, E. D’Hoker, and D. H. Phong. “Two loop superstrings on orbifold compactifications”. *Nucl. Phys.* B688 (2004), pp. 3–69. arXiv: hep-th/0312181 [hep-th].
- [156] E. D’Hoker, M. B. Green, B. Pioline, and R. Russo. “Matching the D^6R^4 interaction at two-loops”. *JHEP* 01 (2015), p. 031. arXiv: 1405.6226 [hep-th].
- [157] B. Pioline and R. Russo. “Infrared divergences and harmonic anomalies in the two-loop superstring effective action”. *JHEP* 12 (2015), p. 102. arXiv: 1510.02409 [hep-th].
- [158] I. Florakis and B. Pioline. “On the Rankin-Selberg method for higher genus string amplitudes” (2016). arXiv: 1602.00308 [hep-th].
- [159] H. Kawai, D. C. Lewellen, J. A. Schwartz, and S. H. H. Tye. “The Spin Structure Construction of String Models and Multiloop Modular Invariance”. *Nucl. Phys.* B299 (1988), pp. 431–470.
- [160] B. Aaronson, S. Abel, and E. Mavroudi. “On interpolations from SUSY to non-SUSY strings and their properties” (2016). arXiv: 1612.05742 [hep-th].
- [161] G. von Gersdorff and A. Hebecker. “Radius stabilization by two-loop Casimir energy”. *Nucl. Phys.* B720 (2005), pp. 211–227. arXiv: hep-th/0504002 [hep-th].
- [162] E. Witten. “Superstring Perturbation Theory Revisited” (2012). arXiv: 1209.5461 [hep-th].

- [163] E. Witten. “More On Superstring Perturbation Theory: An Overview Of Superstring Perturbation Theory Via Super Riemann Surfaces” (2013). arXiv: 1304.2832 [hep-th].
- [164] A. Sen. “Ultraviolet and Infrared Divergences in Superstring Theory” (2015). arXiv: 1512.00026 [hep-th].
- [165] E. Dudas, G. Pradisi, M. Nicolosi, and A. Sagnotti. “On tadpoles and vacuum redefinitions in string theory”. *Nucl. Phys.* B708 (2005), pp. 3–44. arXiv: hep-th/0410101 [hep-th].
- [166] C. Angelantonj and E. Dudas. “Metastable string vacua”. *Phys. Lett.* B651 (2007), pp. 239–245. arXiv: 0704.2553 [hep-th].
- [167] N. Kitazawa. “Tadpole Resummations in String Theory”. *Phys. Lett.* B660 (2008), pp. 415–421. arXiv: 0801.1702 [hep-th].
- [168] A. Sen. “Supersymmetry Restoration in Superstring Perturbation Theory”. *JHEP* 12 (2015), p. 075. arXiv: 1508.02481 [hep-th].
- [169] R. Pius, A. Rudra, and A. Sen. “String Perturbation Theory Around Dynamically Shifted Vacuum”. *JHEP* 10 (2014), p. 70. arXiv: 1404.6254 [hep-th].
- [170] R. Dijkgraaf, E. P. Verlinde, and H. L. Verlinde. “ $C = 1$ Conformal Field Theories on Riemann Surfaces”. *Commun. Math. Phys.* 115 (1988), pp. 649–690.
- [171] N. Arkani-Hamed, L. J. Hall, Y. Nomura, D. Tucker-Smith, and N. Weiner. “Finite radiative electroweak symmetry breaking from the bulk”. *Nucl. Phys.* B605 (2001), pp. 81–115. arXiv: hep-ph/0102090 [hep-ph].
- [172] D. M. Ghilencea, H. P. Nilles, and S. Stieberger. “Divergences in Kaluza-Klein models and their string regularization”. *New J. Phys.* 4 (2002), p. 15. arXiv: hep-th/0108183 [hep-th].
- [173] S. Abel and R. J. Stewart. *in preparation*.

- [174] I. Bena, M. Graña, S. Kuperstein, P. Ntokos, and M. Petrini. “D3-brane model building and the supertrace rule”. *Phys. Rev. Lett.* 116.14 (2016), p. 141601. arXiv: 1510.07039 [hep-th].