

## Durham E-Theses

---

*Composing Music for Acoustic Instruments and  
Electronics Mediated Through the Application of  
Microsound*

MARC LUCIO ESTIBEIRO

### How to cite:

---

ESTIBEIRO, MARC LUCIO (2016) *Composing Music for Acoustic Instruments and Electronics Mediated Through the Application of Microsound*. Doctoral thesis, Durham University.

### Use policy

---

The full-text may be used and/or reproduced, and given to third parties in any format or medium, without prior permission or charge, for personal research or study, educational, or not-for-profit purposes provided that:

- a full bibliographic reference is made to the original source
- a <https://etheses.durham.ac.uk/id/eprint/11469/> is made to the metadata record in Durham E-Theses
- the full-text is not changed in any way

The full-text must not be sold in any format or medium without the formal permission of the copyright holders.

Please consult the [full Durham E-Theses policy](#) for further details.

**Composing Music for Acoustic Instruments and  
Electronics Mediated Through the Application of  
Microsound**

**Marc Estibeiro**

**Submitted in Partial Fulfilment of the Requirements of the  
Degree of  
Doctor of Philosophy in Composition**

**Department of Music  
Durham University**

**2015**



## **Abstract**

This project seeks to extend, through a portfolio of compositions, the use of microsound to mixed works incorporating acoustic instrument and electronics. Issues relating to the notation of microsound when used with acoustic instruments are explored and the adoption of a clear and intuitive system of graphical notation is proposed. The design of the performance environment for the electroacoustic part is discussed and different models for the control of the electronics are considered. Issues relating to structure and form when applied to compositions that mix note-based material with texture-based material are also considered. A framework based on a pure sound/noise continuum, used in conjunction with a hierarchy of gestural archetypes, is adopted as a possible solution to the challenges of structuring mixed compositions. Gestural and textural relationships between different parts of the compositions are also explored and the use of extended instrumental techniques to create continua between the acoustic and the electroacoustic is adopted. The role of aleatoric techniques and improvisation in both the acoustic and the electroacoustic parts are explored through adoption of an interactive performance environment incorporating a pitch-tracking algorithm. Finally, the advantages and disadvantages of real time recording and processing of the electronic part when compared with live processing of pre-existing sound-files are discussed.



## Table of Contents

<b>Abstract</b> .....	<b>i</b>
<b>Table of Figures</b> .....	<b>v</b>
<b>List of Compositions</b> .....	<b>ix</b>
<b>Acknowledgements</b> .....	<b>xi</b>
<b>Introduction</b> .....	<b>1</b>
Definition of terms .....	6
Concatenative synthesis .....	8
Contribution to knowledge .....	8
<b>Chapter 1: Early Uses of Microsound as a Compositional Device</b> .....	<b>10</b>
Xenakis' applications of microsound .....	10
Curtis Roads: first computer implementation of granular synthesis .....	12
Real time granulation of soundfiles – <i>Riverrun</i> .....	14
More recent examples of granulation in mixed compositions.....	15
<b>Chapter 2: Definition of Microsound and The Compositional Affordances of Microsound</b> .....	<b>17</b>
<b>Chapter 3: Composition for Flute, Bass Clarinet, Piano and Electronics – <i>The Sea Turns Sand to Stone</i>. Structure and Form, Notation and Extended Techniques in the Context of Microsound</b> .....	<b>22</b>
Structure and form in <i>The Sea Turns Sand to Stone</i> .....	22
The use of extended techniques to create perceptual continua between sensory “consonance” and “dissonance” .....	33
Mapping affordances from the microsound environment onto the sensory consonance/dissonance axis.....	40
Notating the electronic part in <i>The Sea Turns Sand to Stone</i> .....	49
Background to the choice of notational symbols.....	60
<b>Chapter 4: Composition for Piano and Electronics: <i>Thin Red Vein</i>. The Use of Microsound to Explore and Manipulate Gestural Surrogacy and Gesture/Texture Relationships</b> .....	<b>62</b>
Definitions of gesture.....	63
Using microsound to suggest a transfer of acoustic energy from the acoustic to the electroacoustic.....	64
Adapting a taxonomy of gestural archetypes.....	65
Using Boulezian signals as musical discourse markers .....	67
Applying gestural archetypes to create relationships between different elements	68
The harmonic language used in the acoustic part of <i>Thin Red Vein</i> .....	73
<b>Chapter 5: Composition for Piano, Bass Clarinet and Electronics: <i>With Time Not In Time</i>. Issues of Control and Interface Design and the Roles of the Performer, the Composer and the Listener</b> .....	<b>74</b>
Using acoustic instruments in an acousmatic context .....	74
Affordance and constraint .....	80
Models and precedents for controlling electronics when used with acoustic instruments in real-time performance.....	83
Human control of electronics .....	83
Machine control of electronics.....	85
The automated score: recording controller data for playback during performance .....	85
Machine listening.....	87
Score following.....	89
Designing an interactive interface .....	90

Defining the boundaries for improvisation in the score .....	91
The harmonic language used in <i>With Time Not In Time</i> .....	93
Issues arising from the use of an interactive environment.....	95
<b>Chapter 6: Composition for Piano, Flute, Bass Clarinet and Electronics:</b>	
<b><i>Interventions. Composition for Contrabass Flute, 'Cello and Electronics: Earth</i></b>	
<b><i>White Fracture. Conflicts Between Note based and Texture Based Approaches to</i></b>	
<b><i>Composition. Using Microsound to Manipulate a Range of Materials across a</i></b>	
<b>Structural Framework.....</b>	<b>97</b>
Note-based and texture-based approaches to composition .....	97
Features of the composition: <i>Interventions</i> .....	98
The electronic performance environment and score .....	99
Limitations of live recordings .....	100
The use of note based material in acoustic part of <i>Interventions</i> .....	102
An integrated, structural approach to the creation of a continuum between the	
acoustic and the electroacoustic.....	104
<b>Chapter 7: Composition for Six Instruments and Electronics: <i>Displaced Light</i></b>	
<b>Using Microsound Techniques to Create and Extend a Repertoire of Gestural</b>	
<b>Archetypes.....</b>	<b>107</b>
Aims of the composition.....	107
Harmonic structure .....	108
Instrumentation and relationship to electronics.....	111
Classification of gestural archetypes used.....	119
Electroacoustic Structure.....	123
Creating a unified work through the application of multiple structural frameworks	
.....	134
The implications of using a simple symbolic graphic notation system which is both	
prescriptive and descriptive.....	134
<b>Conclusion: Discussion and Recommendations .....</b>	<b>136</b>
<b>Bibliography.....</b>	<b>139</b>

## Table of Figures

Figure 1: Examples of grain envelopes .....	13
Figure 2: Emmerson's model of composition: adapted from (Emmerson, Composing Strategies and Pedagogy, 1989) .....	26
Figure 3: Conceptual continuities between sensory dissonance and consonance (Source: author's own) .....	32
Table 1: Temporal relationships between different sections in <i>The Sea Turns Sand to Stone</i> .....	33
Figure 4: A Schematic for <i>The Sea Turns Sand to Stone</i> showing morphologies between sensory consonance and dissonance. Microstructure is reflected in the macrostructure .....	33
Table 2: Gestures used by the bass clarinet in <i>The Sea Turns Sand to Stone</i> ordered from sensory consonance to dissonance .....	34
Figure 5: Bass clarinet F2 senza vibrato (Cue 1) .....	34
Figure 6: Bass Clarinet F2 senza vibrato (Cue 4) .....	35
Figure 7: Trill (Cue 7) .....	35
Figure 8: Bass clarinet slap tongue (Cue 10) .....	35
Figure 9: Bass clarinet multiphonic (Cue 13) .....	35
Figure 10: Bass Clarinet high flutter tongue (Cue 16) .....	35
Figure 11: Bass Clarinet unpitched air notes (Cue 19) .....	35
Table 3: Gestures used by the piano ordered from pure sound to noise .....	36
Figure 12: Piano chord .....	36
Figure 13: Piano iterative gesture 1 .....	36
Figure 14: Piano pushing agitated gesture .....	37
Figure 15: Piano harmonic .....	37
Figure 16: Piano harmonic and scraping gesture .....	37
Figure 17: Piano scraping gesture then harmonic .....	37
Figure 18: Piano slide bouncing off strings .....	37
Table 4: Gestures used by the flute ordered from pure sound to noise .....	37
Figure 19: Flute F#6 harmonic (cue 6) .....	38
Figure 20: Flute timbral trill (cue 12) .....	38
Figure 21: Flute ord to flz (cue 9) .....	38
Figure 22: Flute short staccato flutter tongue .....	38
Figure 23: Flute senza vibrato (Cue 3) .....	38
Figure 24: Flute tongue ram (cue 15) .....	39
Figure 25: Flute pizz .....	39
Figure 26: Flute wind tone to ord .....	39
Figure 27: Flute whistle tone (Cue 9) .....	39
Figure 28: Flute high flutter tongue (Cue 18) .....	39
Figure 29: Flute jet whistle (cue 21) .....	39
Figure 30: Overview of the electronic performance environment .....	40
Table 5: User adjustable parameters, together with the abbreviations used to send messages to the parameters in the Max environment .....	41
Figure 31: <i>The Sea Turns Sand to Stone</i> Electronics section 1 .....	44
Figure 32: <i>The Sea Turns Sand to Stone</i> Electronics section 2 .....	44
Figure 33: <i>The Sea Turns Sand to Stone</i> Electronics section 3 .....	45
Figure 34: <i>The Sea Turns Sand to Stone</i> Electronics section 4 .....	46

Figure 35: <i>The Sea Turns Sand to Stone</i> Electronics section 5.....	47
Figure 36: <i>The Sea Turns Sand to Stone</i> Electronics section 6.....	48
Figure 37: <i>The Sea Turns Sand to Stone</i> Electronics section 7.....	48
Figure 38: <i>Mikrophonie I</i> (1966) Stockhausen. An example of an early graphical notational score for live electronics.....	53
Figure 39: Increase grain size.....	57
Figure 40: Decrease grain size .....	57
Figure 41: Decrease grain density .....	57
Figure 42: Increase grain density .....	58
Figure 43: Reorder elements .....	58
Figure 44: Add partials (through comb filtering or amplitude modulation) .....	58
Figure 45: Gradually add partials .....	58
Figure 46: Shift frequency up .....	58
Figure 47: Shift frequency down.....	58
Figure 48: Spectral delay.....	58
Figure 49: Time stretch .....	59
Figure 50: Time contraction.....	59
Figure 51: Opening phrase of <i>Thin Red Vein</i> showing the initial percussive gesture, the framing texture and the response .....	67
Figure 52: "Push" type percussive gesture .....	68
Figure 53: "Strike" type percussive gestures.....	69
Figure 54: Extended "push" gesture in the acoustic part and its transformation into an ambiguous gestural/textural relationship in the electroacoustic part .....	69
Figure 55: Iterative gestures in the piano part framed by a denser texture in the electroacoustic part.....	71
Figure 56: Further iterative gestures in the piano part framed by textures created using very slow playback speeds and very short grain durations in the electroacoustic part.....	71
Figure 57: An abrupt fade in the electroacoustic part coinciding with a sudden rapid descending gesture in the piano part to suggest a causal relationship .....	72
Figure 58: A variety of gestural archetypes in the acoustic part juxtaposed with interpolating grain sizes, pitch and playback speeds in the electroacoustic part to suggest dialogue and causal relationships.....	73
Figure 59: Chord progression used as a compositional resource for <i>Thin Red Vein</i> .....	73
Figure 60: Models and relationships for the control of electronics.....	83
Figure 61: An early version of the interface used for the compositions in the portfolio. This interface was capable of recording and playing back controller data .....	86
Figure 62: Representational levels of music. Adapted from (Cont, 2010).....	87
Figure 63: Examples possible data for machine recognition.....	88
Figure 64: The interface for the interactive Max patch used by the performers for <i>With Time Not In Time</i> and <i>Five Pieces for Saxophone and Electronics</i> .....	90
Figure 65: Improvisation section from <i>With Time Not In Time</i> .....	92
Figure 66: Excerpt from <i>With Time Not In Time</i> showing the use of trigger notes and amplitude thresholds.....	93
Figure 67: First pitch set used in <i>With Time Not In Time</i> .....	93

Figure 68: Second pitch set used in <i>With Time Not In Time</i> .....	94
Figure 69: Transformation from first pitch set.....	94
Figure 70: Gesture constructed from first and second pitch sets .....	94
Figure 71: Examples of chords constructed from pitch sets .....	94
Figure 72: Examples of bass clarinet multiphonics used in <i>With Time Not In Time</i> .....	95
Figure 73: Performance environment used for <i>Interventions</i> .....	99
Figure 74: Excerpt from score for <i>Interventions</i> showing cue numbers, record and notation for electronics .....	100
Figure 75: The beginning of the piano part of <i>Interventions</i> showing the number series used in the left hand and the right hand.....	102
Figure 76: Original chord from <i>Interventions</i> .....	103
Figure 77: Pitches derived from original chord for <i>Interventions</i> .....	103
Figure 78: Symmetrical pitch set for <i>Interventions</i> .....	103
Figure 79: Original harmonic series for <i>Interventions</i> .....	103
Figure 80: Chords paired with chromatic inversions.....	104
Figure 81: Bass sequence derived from lowest note of chord sequence for <i>Interventions</i> .....	104
Figure 82: Octatonic scale used for the contrabass flute part in <i>Earth White</i> <i>Fracture</i> .....	105
Figure 83: The structural framework used as a guide during the composition of <i>Earth White Fracture</i> .....	106
Figure 84: Root plus minor 2nd with augmented triad 5th above root.....	108
Figure 85: The same chord inverted around F4 and transposed up one octave	109
Figure 86: Transposing each degree of the chord (except the top note) downwards by an increasing number of semitones to create a new chord .....	109
Figure 87: the chord from fig 72, together with the original chord, adjusted to avoid octaves.....	109
Figure 88: Harmonic structure of the composition.....	110
Figure 89: Overall structure of the composition showing relationship between noise and pure sound and the harmonic basis .....	111
Table 6: Gestural archetypes used in the composition listed by instrument and in the order in which they appear.....	113
Figure 90: Principal gestural archetypes used in section A .....	114
Figure 91: Principal gestural archetypes used in section B.....	115
Figure 92: Principal gestural archetypes used in section C.....	116
Figure 93: Principal gestural archetypes used in section D .....	117
Figure 94: Principal gestural archetypes used in section E.....	118
Table 7: Principal categories used for gestural archetypes.....	119
Figure 95: Vibraphone gestural archetype 1. Slow attack and continuation: bowed note with harmonic .....	119
Figure 96: Vibraphone gestural archetype 2. Iteration: rapidly repeated note..	119
Figure 97: Vibraphone gestural archetype 3. Short attack and decay - strike gesture .....	120
Figure 98: Vibraphone gestural archetype 4. Iteration 2 - push gesture.....	120
Figure 99: Vibraphone gestural archetype 5. Rapid burst and decay. Strike/push gesture .....	120

Figure 100: Vibraphone gestural archetype 6. Rapid burst and continuation. Strike/push and continuation.....	120
Figure 101: Vibraphone gestural archetype 7. Longer phrases with a mixture of regular and irregular rhythms. Mixture of slow decay and abrupt decay....	120
Figure 102: 'Cello gestural archetype 1. Slow attack and continuation: pure sound moving to noise and back through increased bow pressure.....	120
Figure 103: Variation of gestural archetype 1. Slow attack and continuation: gradually reducing finger pressure to move from stopped note to harmonic sound .....	121
Figure 104: 'Cello gestural archetype 2. Iteration, rapidly repeated note: Harmonic perfect 5 <sup>th</sup> above stopped note: trill between stopped note combined with glissandi. Pure sound moving towards noise through moving bow position from fingerboard to bridge .....	121
Figure 105: 'Cello gestural archetype 3. Short attack and decay .....	121
Figure 106: 'Cello gestural archetype 4: push gesture .....	121
Figure 107: 'Cello gestural archetype 5: rapid burst and decay: strike/push gesture .....	121
Figure 108: 'Cello gestural archetype 6: rapid burst and continuation: strike/push and continuation.....	122
Figure 109: longer phrases with a mixture of regular and irregular rhythms: mixture of short and long decays .....	122
Figure 110: Double bass gestural archetype 1: slow attack and continuation: bowed note with and without harmonic.....	122
Figure 111: Double bass gestural archetype 2: iteration: tremolo between stopped note and artificial harmonic .....	122
Figure 112: Double bass gestural archetype 3: short attack and decay.....	122
Figure 113: Double bass gestural archetype 4: iteration: push gesture .....	123
Figure 114: Double bass gestural archetype 5: rapid burst and decay: strike push gesture .....	123
Figure 115: Double bass gestural archetype 6: rapid burst and continuation: strike/push and continuation.....	123
Figure 116: Double bass gestural archetype 7: longer phrases with irregular rhythms: mixture of short and long decays .....	123
Figure 117: Broad schematic demonstrating how the extent of the electronic part gradually increases from the centre of each section until, by the centre of the composition, the electronics play throughout the majority of the section. The process is then reversed .....	124
Table 8: Parameters used for the control of the electronic part together with abbreviation .....	124
Figure 118: Electronics Channel 1 Schematic .....	126
Figure 119: Electronics channel 2 schematic .....	127
Figure 120: Electronics channel 3 schematic .....	128
Figure 121: Electronics section A1 schematic.....	129
Figure 122: Electronics section B1 schematic.....	130
Figure 123: Electronics section C1 schematic.....	131
Figure 124: Electronics section D1 schematic.....	132
Figure 125: Electronics section E schematic.....	133

## List of Compositions

*Interventions* for Flute, Bass Clarinet, Piano and Electronics

(First performance: 21<sup>st</sup> June 2014 as part of the Durham University Klang 2014 concert series)

Flute: Richard Craig  
Bass Clarinet: Dov Goldberg  
Piano: John Snijders  
Electronics: Marc Estibeiro

*With Time not In Time* for Bass Clarinet, Piano and Electronics

(First performance: 17<sup>th</sup> February 2015 at the Axis Arts Centre, Crewe)

Bass Clarinet: Sarah Watts  
Piano: Antony Clare  
Electronics: Marc Estibeiro

*Thin Red Vein* for Piano and Electronics

(Recorded at the Zurich Institute of the Arts 19<sup>th</sup> January 2015)

Piano: Michael Kielser  
Electronics: Marc Estibeiro

*The Sea Turns Sand to Stone* for Flute, Bass Clarinet, Piano and Electronics

(Winner of the William Mathias Composition Prize, 2015)

First Performance: 8<sup>th</sup> March 2015 at Bangor University as part of the Bangor Music Festival, 2015)

Flute: Carla Rees  
Bass Clarinet: Heather Roche  
Piano: Xenia Pestova  
Electronics: Marc Estibeiro

*Earth White Fracture* for Contrabass Flute, 'Cello, and Electronics

(First performance: 3<sup>rd</sup> June 2015 at Durham University as part of the Durham Klang 2015 concert series)

Contrabass Flute: Richard Craig  
'Cello: Seth Woods  
Electronics: Marc Estibeiro

*Displaced Light* for Flute, Bass Clarinet, Vibraphone, Piano, 'Cello, Double Bass, and Electronics

(Unperformed)

*Five Pieces for Saxophone and Electronics* for Baritone Saxophone and Electronics

(First performance: 4<sup>th</sup> May 2013 at Staffordshire University as part of the Noise Floor 2013 concert series)

Ben Cottrell: Baritone Saxophone  
Marc Estibeiro: Electronics

## Statement of Copyright

*The copyright of this thesis rests with the author. No quotation from it should be published without the author's prior written consent and information derived from it should be acknowledged.*

## **Acknowledgements**

I would like to thank my supervisors, Peter Manning and Sam Hayden, for the support, encouragement and guidance they have given me during the course of this project. I would also like to thank Richard Rijnvos for his invaluable help and advice particularly with regard to notation.

I would like to thank all of the musicians who have performed on these compositions in the workshops, concerts and recordings that have taken place during the course of this project. In particular I would like to thank:

Matthias Muller	Bass Clarinet
Dov Goldberg	Bass Clarinet
Sarah Watts	Bass Clarinet
Heather Roche	Bass Clarinet
John Snijders	Piano
Antony Clare	Piano
Michael Kielser	Piano
Xenia Pestova	Piano
Richard Craig	Flute
Rafal Zolkos	Flute
Alejandro Escuer	Flute
Carla Rees	Flute
Ben Cottrell	Saxophone
Seth Woods	'Cello
Myrtille Hetzel	'Cello

The Ives Ensemble

I would like to thank the School of Film, Sound and Vision and the Centre for Media, Arts and Technology at Staffordshire University for supporting this project. In particular I would like to thank Dave Newman and Catherine Fehily.

Finally, I would like to thank my family, Isobel, Xavier, Lucio and in particular Sarah for their encouragement and patience over the last few years. The portfolio is dedicated to them.



## Introduction

'Microsound' is, broadly, the manipulation of sounds of very short duration for composition. The term was made popular by Curtis Roads (Roads, 2001) although it appears in the writings of Xenakis as early as 1971 (Xenakis, 1971). As an electronic, computer assisted process it became viable as a compositional tool through developments in computing technology in the 1970s, although earlier analogue examples of microsound composition exist, such as Xenakis' *Concret PH* for tape (1958). Examples of microsound techniques are granular synthesis and various spectral processing techniques based on Fourier transforms. Granular synthesis was first used as a compositional tool by Curtis Roads and Barry Truax (Roads, 1978) (Truax, 1986). Today when affordable personal computers have clock speeds and memory specifications that would have been almost unimaginable to most people even a decade ago, spectral processing techniques are routinely used creatively and correctively in many different areas of music. Tools and environments for granular synthesis are also included in many different commercially available software products.

The compositional potential of microsound has given rise to a diverse range of composers exploring the possibilities of manipulating sound on very small time scales through a variety of techniques and much has been written on what Curtis Roads termed microsound, most notably of course by Roads himself (Roads, 2001). However, although the term microsound is often used as a genre as well as a technique, in reality it refers to a variety of often quite different musical styles, which extend from highly academic, institutionally produced computer music to work produced by individual composers or sound artists more influenced by a wider electronica derived mainly from pop music culture (Thompson, 2004).

One approach, for example, is to take environmental sounds and explore their inner complexities. Barry Truax and other composers associated with the World Soundscape Project have used this approach to comment upon the socio-political relationships that are inherent in modern sonic landscapes (Truax, 2001). Other

compositions explore more technical aspects of the processes, such as different ways of manipulating or controlling grains, or using different probability functions to distribute grains in time and space. Other artists, such as Kim Cascone, use microsound to create compositions and sound design that sit comfortably in both an academic and a commercial context. It is clear therefore, that microsound is an approach and a technique that can be used by a diverse range of artists with a similar diversity of aesthetic aims and principles.

This leads to two challenges for the contemporary composer. Given the diversity of genres available, one of the challenges is to identify an original approach and to explore its possibilities. One area in which there is a more limited body of composition is the systematic use of microsound to interact with traditional acoustic instruments. Composers such as Barry Truax have used microsound techniques in compositions incorporating acoustic instruments with electronics but largely as tools to expose hidden morphologies in the source material or to “...preserve and amplify typical improvisational gestures used by the performer, sometimes stretching them in time to discover their inner complexity” (Truax, *Bamboo, Silk and Stone*, 1995). Using the compositional affordances of microsound explicitly as a way of uniting an acoustic sound world with an electroacoustic sound world is a more novel approach. In this way microsound becomes a bridge between two very different and often contradictory traditions, performance practices and approaches to composition. The approaches are contradictory because, with many exceptions, one tends to favour a note-based approach whilst the other favours a texture-based approach. These different approaches will be explored more fully in a later section. The aim of this project, therefore, is to explore, through a portfolio of compositions, the creative possibilities and the practical and aesthetic implications which arise when composing music which combines acoustic instruments with electroacoustic music through the techniques and the aesthetics of microsound; the goal is to use microsound as the primary focus and guiding aesthetic principle to enhance and extend compositions for acoustic instruments with electronics.

Another major challenge to the composer, when producing a portfolio of compositions such as the one for this project, is how to evaluate the outcome. The multiplicity of approaches to compositional use of microsound has already been referred to but adds to the challenge of finding suitable aesthetic criteria against which to evaluate compositions. There is clearly an inherent problem in evaluating the particularity of a specific composition against general aesthetic criteria. This issue will be addressed later in this commentary, but ultimately, perhaps, it must be the artists themselves who impose a set of criteria against which their own body of work is being assessed.

The commentary is organised as follows. **The first section** provides a brief overview of some early uses of microsound as a compositional device. It begins by considering how Xenakis first applied the ideas of Denis Gabor to his own compositions. It then continues with a brief discussion of the first computer implementations of granular synthesis by Curtis Roads and Barry Truax's pioneering real time implementation of granular synthesis in the 1980s. Many of the ideas discussed are still relevant today and where there are connections to the compositions included with this commentary or the software environment used to create the electroacoustic sounds, these have been highlighted. The section concludes by discussing some more recent examples of the use of granular synthesis in mixed compositions.

**The second section** begins by providing a more precise definition of the term microsound as it is used in the context of this commentary. This is followed by a discussion of the compositional affordances of microsound specifically with reference to how they are presented in the software environment used for the majority of compositions in the accompanying portfolio. The aesthetics of composing with microsound are explored and the implications of applying the technique to works involving acoustic instruments are considered.

**The third section** examines issues relating to structure and form, notation, and extended instrumental techniques when composing for acoustic instruments and microsound. The issues are examined in the context of the portfolio composition

for flute, bass clarinet, piano and electronics: *The Sea Turns Sand to Stone*. This section explores the ways in which microsound can be applied to the use of texture as an organising principle, and how a continuum between pure sound, (or sounds which tend towards periodic sinusoidal single frequencies), and noise, (or sounds which tend towards aperiodic, chaotic spectra), provides one solution to the problem of structuring compositions incorporating microsound.

**The fourth section** discusses issues relating to gestural surrogacy and gesture/texture relationships specifically as they emerge in the portfolio composition for piano and electronics: *Thin Red Vein*. This section considers how microsound can be used to manipulate aural and mimetic relationships and how transformations and ambiguities between gesture and texture can be used as an organising principle.

**The fifth section** explores issues of control of the electroacoustic sound world, interface design, the role of the performer and the relationship between the performer and the composer. These considerations are discussed in the context of the portfolio composition for piano, bass clarinet, and electronics: *With Time Not In Time* and the portfolio composition for baritone saxophone and electronics: *Five Pieces for Saxophone and Electronics*. Issues such as how best to design and control digital performance environments that make use of microsound are central to these critiques. The differences between digital and acoustic instruments are considered with particular reference to interface design informed by ideas of affordances and constraints. From this follows a discussion of the control of electronic environments when used with acoustic instruments for real time performance. The benefits and disadvantages of different models are also discussed, including human control, machine control, and the use of machine listening and score following systems such as IRCAM's *Antescofo*.

In **the sixth section** the conflict between a note based approach to composition and a texture based approach is considered in the context of the portfolio composition for piano, flute, bass clarinet and electronics, *Interventions* and the portfolio composition for contrabass flute, cello, and electronics, *Earth White*

*Fracture*. The implications of combining the often-contradictory traditions of acoustic instruments and electronics are discussed. The ways in which these two different sound worlds can relate to each other are examined, along with the implications of combining pitch based material with texture based material. The discussion explores the extent to which different timescales and perspectives implied by different methods of musical structuring associated with pitch and timbre as their primary constituent can be united through the use of microsound as the primary organising principle. This leads to a discussion on the ways in which acoustic instruments can be combined with electroacoustic transformations of their sounds. *Earth White Fracture* is also used to demonstrate how a list of techniques and gestures can be constructed for each instrument in order to create a range of materials which extend across an organising continuum and which can then be further extended and manipulated through the use of microsound.

Finally, **the seventh section** provides a detailed overview of compositional process behind the major composition. The work demonstrates how microsound techniques can be applied to a composition where texture and harmony are treated as separate but integrated elements with frequent points of contact. The piece also demonstrates how acoustic elements and electroacoustic elements can be integrated from the earliest stages of the compositional process through the use of microsound. It also serves as a further example of notation for the electronic part which is both meaningful and intuitive. Finally the composition demonstrates further the application of microsound techniques in conjunction with instrumental techniques to create a coherent structure based on a pure-sound/noise axis.

Throughout the commentary, the ideas and techniques discussed are referenced to the portfolio of compositions that are integral to this project. However, it is important to note that the compositions have not been specifically designed to implement the main themes in this commentary. Rather, the themes emerge from a consideration of the issues that arise through an application of the compositional process. That is to say, the compositions have not been created

merely to demonstrate proof of concept but with the intention that they are worthwhile creative outcomes in themselves, which demonstrate an originality of approach and constitute a significant addition to the electroacoustic repertoire. It should also be noted that although different issues have been presented in relation to specific compositions, there is a considerable crossover of ideas among the pieces which make up the portfolio. The compositions are thus not intended to be considered as discrete works which only function to illustrate the ideas presented in the corresponding sections of the commentary.

The commentary **concludes** with an appraisal of the affordances of microsound as a compositional approach and a critical discussion on the extent to which they have been successful as applied to the compositions in the portfolio.

All of the electroacoustic sounds created for this portfolio have been designed using bespoke performance environments for granular synthesis and FFT based spectral processing written in Cycling 74's Max 6. Although the underlying techniques are not in themselves original, the ways in which they have been crafted and applied are designed to generate new perspectives on their creative possibilities. Some of the pitch-based material used in the acoustic parts of the compositions has been composed with, or indirectly inspired by, environments created in IRCAM's Open Music.

### **Definition of terms**

Throughout this commentary certain terminologies are used which, although in common usage, can often have ambiguous or even contradictory meanings in different contexts. It is appropriate, therefore to define these terms as clearly as possible in order that their use in the context of this commentary is clear. At the heart of the portfolio is the connection between electroacoustic and acoustic music. The electroacoustic elements are considered to be acousmatic in the broadest sense when the causes or the sources of the sounds are hidden or obscured. The term "acousmatic" in this commentary takes Smalley's definition of the term in (Smalley, 1997) as a starting point. Acousmatic music therefore is

“...music where (in live performance) the sources and the causes of the sounds are invisible – a music for loudspeakers alone, or music which mixes live performance with an acousmatic, loudspeaker element.” (Smalley D. , 1997, p. 109). The definition, however, can also be applied to instrumental music where listeners cannot connect the sounds heard with observed (or imagined) physical activity, which supposedly produces those sounds. The term “acoustic” is used to refer to music played on physical instruments with no electronic processing which would alter the nature of the sounds produced to such an extent as to blur the connection between the instrument and its output. Thus, as the term is defined here it is possible to add a small amount of electronically produced reverberation or amplification to the instrumental output for the purposes of sound reinforcement and blending and for that output still to be considered “acoustic”. As soon as any other processing is used which significantly changes the spectral content of the instrumental output the sounds are considered to be acousmatic. It should be noted however that there are examples of purely instrumental music which could be considered acousmatic. The instrumental work of composers such as Grisey or Murail, for example, tends to focus on spectral and textural complexities in such a way that the traditional identities of the instruments are often lost or obscured and the music could be considered acousmatic.

The distinction between the acoustic and the acousmatic, therefore, is not always clear and there are many examples where a sound could satisfy both definitions. As a broad generalisation, however, the term “acoustic” will be used in the context of this commentary to refer to music played on traditional musical instruments where the relationship between the source and the material is clear and the term “acousmatic” will be used to refer to sounds which have been processed electronically and where the relationship between the sound and the cause or source of the sound is lost or obscured. The term “electroacoustic” will also be used as a more neutral term to refer to those elements of the music that are produced electronically.

When applying the aesthetics and terminology of electroacoustic music to acoustic instrumental music, an important precedent to consider is the work of Helmut Lachenmann. Lachenmann used ideas from Pierre Schaeffer in an instrumental context, thus introducing the idea of *musique concrète instrumentale* (Orning, 2012). In Lachenmann's music instruments are typically separated from their traditional performance practices as artefacts conventionally considered to be extra musical form the bulk of the compositional material. Lachenmann's music is thus texture based rather than note based and his use of notation is prescriptive rather than descriptive. These ideas are discussed more fully in Chapter 3 and Chapter 6.

### **Concatenative synthesis**

Since 2004 an important development in granular synthesis and microsound techniques has been the introduction of concatenative synthesis (Schwarz, 2004). Concatenative synthesis is an analysis based granulation technique where a corpus of segmented and descriptor analysed sounds are used to synthesise new sounds based on proximity to target values. Examples of its implementation can be found in environments such as IRCAM's CataRT (IRCAM, 2014). Concatenative synthesis does not feature in this commentary, however, as it was felt that the traditional approach to granulation initiated by Truax and Roads still offered great potential that was yet to be explored and which justified further intensive research and study.

### **Contribution to knowledge**

This research makes the following contributions to knowledge:

- It offers a further investigation of the potential of granulation in the live sphere, specifically by using microsound to blur distinctions and to emphasise connections and interrelationships between sounds in the acoustic and the electronic domains.
- It contributes a portfolio of compositions for acoustic instruments and live electronics which adds to and extends the existing body of work in the area. It does this specifically by using microsound, realised mainly through granulation, as the primary focus and guiding aesthetic principle

in both the acoustic and the electronic domains, and where an ambiguity as to the origins of the sounds in both domains is realised and explored in a novel way through microsound.

- By placing emphasis upon the use of microsound, it brings together the traditions of electroacoustic and instrumental composition by applying elements from each tradition to both domains in such a way as to bring to the fore the mutual influences, interrelationships and continuities.
- It provides a portfolio of compositions using microsound in which the output of the acoustic instruments is always used as the source material for the electronic processing and where it is always possible to hear some element of the source material, however remotely, despite processing.
- It focuses on the use of microsound to create structural frameworks which emphasise connections and perceptual continua between the acoustic and the electronic domains
- It makes specific use of microsound as a technique to unite note-based and texture-based approaches to composition.
- It contributes to, and extends, existing notational systems for mixed compositions by using a new system of notational symbols for the electronic part, which is both descriptive and prescriptive and which integrates with the notation for the acoustic elements.

## Chapter 1: Early Uses of Microsound as a Compositional Device

### Xenakis' applications of microsound

The idea of using large numbers of sounds of very short duration as a viable compositional tool was explored by Iannis Xenakis as early as the 1950s (Roads, 2001, Xenakis 1971). His tape compositions *Concret PH* (1958), *Bohor I* (1962) and *Persepolis* (1971), for example, feature complex textures built from granular material. As early as 1955 ideas could be found in his composition for 61 instruments, *Metastasis*, which were to become important in the development of granular composition. This eight-minute piece, which shows the musical influence of Olivier Messiaen and the mathematical and formal influences of Le Corbusier, challenged linear perceptions of time in music and explored the relationship between single events and the stochastic, non-deterministic nature of soundscapes generated by many thousands of such events. The score of *Metastasis* also allowed individual players to be responsible for certain aspects of the composition, such as completing glissandi within specified pitch boundaries and timescales.

This model of control demonstrated a relationship between the composer and the orchestra that prefigured the compositional control strategies between composer and computer that would be implemented by Barry Truax and Curtis Roads decades later. Indeed, similar control strategies can be found in both the scores and the software environments for the compositions that form the basis of this commentary. *Metastasis* begins with 46 individual string parts playing in unison before they diverge on a series of carefully plotted glissandi. The resulting effect is of a texture of evolving sound mass events with extreme alterations of dynamics and timbre. Density and intensity become the dominant organising principles of the piece. Using microsound to create gestural and textural morphologies which then act as structural devices is also a technique used in many of the compositions in the portfolio, particularly in *The Sea Turns Sand to Stone* and *Earth White Fracture*. (The terms “gesture” and “texture” are discussed more fully in a later section). Xenakis' approach, however, is

essentially texture based. That is to say, the note is no longer the fundamental unit of organisation. Although the piece is for acoustic instruments with no use of electronics, it can be thought of as prefiguring an electroacoustic aesthetic and approach to composition. In that sense, it differs from the portfolio compositions where the aim has been to combine a note-based approach with a texture-based approach.

In *Concret PH* (1958), Xenakis developed these ideas further by producing a work for tape based on the sound of burning charcoal. *Concret PH* is a 2' 45" long composition that demonstrates Xenakis' novel approach to texture, form and articulation. The piece is composed entirely of tiny fragments of sound that merge together to form a textural cloud. The recordings of burning charcoal were edited into tiny sections, often significantly less than 100ms long. The brevity of the samples meant that it became very difficult or impossible to perceive specific pitches. Xenakis then used time/density formulae to edit the fragments of tape back together to create new textures with particular temporal densities. (Di Scipio, 1998)

The timbral characteristics of the new textures were dependent on the length of the original fragments of sound and the density of the fragments. There are essentially two types of textures in the composition, textures made from very short fragments where pitch is difficult to determine and textures made from slightly longer fragments where the tonal qualities of the source material is easier to discern. Overlapping sections with different fragment lengths created further effects. Other than some tape manipulation effects, it seems that Xenakis did very little processing on the recordings of the burning charcoal (Roads, 2001). The simple act of reordering the fragments, however, results in new textures where the extrinsic connections to the source material are significantly weakened and mimetic references, or links made by listeners to aspects of nature or culture not immediately present in the piece, are shifted. The piece is structurally quite simple (Di Scipio, 1998) but through this simplicity, the microstructures of the individual grains – intense bursts of energy happening at

unpredictable points and merging together to form coherent evolving textures - are reflected in the macrostructure of the piece as a whole.

Different time scales coexist simultaneously to create a surprisingly complex and varying sonic landscape in which phrase like articulations and linear progression have been eliminated. Many of the ideas embedded in this composition, in particular granulation of concrete sounds, reordering of grains, the effect of grain length and grain density on the overall texture, the effect of changing the pitch of the grains, weakening of mimetic relationships between the source material and the final textures, the co-existence of different time scales, and the symmetry between the microstructures and the macrostructure, have been explored further in the portfolio compositions. These implementations will be discussed more fully in later sections.

*Bohor I* (1962) is another example of Xenakis' granular, textural approach to form. The piece is for eight-channel tape in which four distinct tracks are diffused through pairs of speakers. It is Xenakis' first major electroacoustic composition (Kim, 2000). The source material for the piece consists of a Laotian mouth organ and various foot bracelets and bells. Very soft sounds are amplified in order to bring out their hidden characteristics. Again, as in *Concret PH*, there is no recognisable phrasal articulation and no logical progression. Xenakis is composing in, rather than with the sound material and the piece is, according to Di Scipio, one of the most radical attempts at annulling linear articulation in Western Music of its time (Di Scipio, 1998). There are some similarities between Xenakis' use of the source material in this work and the role of the acoustic instruments in the composition folio although Xenakis' approach to gestural articulation and macrostructure has not generally been followed.

### **Curtis Roads: first computer implementation of granular synthesis**

It was not until 1975, however, that granular synthesis was first implemented on a computer. Curtis Roads, working at the University of California in San Diego, designed a granular synthesis instrument in the Music V language running on a

Burroughs B6700 computer (Roads, 1978). Roads' instrument had a fixed duration and amplitude functions for each grain but variable waveforms, amplitudes and frequencies for the grains. He used grains of 20ms or less, finding 10ms to be a particularly effective length. For the grain envelope, he found that the Gaussian distribution curve suggested by Gabor did not produce an effective amplitude characteristic and the rectangular envelope suggested by Xenakis led to unwanted artefacts in the sound. His solution was an envelope that combined the properties of both curves. The environment for granular synthesis used to design the electroacoustic elements for the majority of compositions in this folio includes the ability to select between six different envelopes. This feature has been hidden as an affordance, however, as it was not felt to be an especially significant compositional attribute in this context.

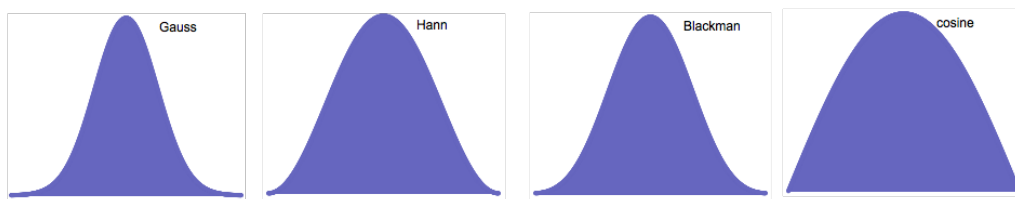

**Figure 1: Examples of grain envelopes**

Roads' instrument used three oscillators and an interpolator with various user definable parameters to output one grain. The first oscillator produced a fixed duration envelope for the grain. The second oscillator generated a sine wave and the third oscillator produced a band-limited pulse; the outputs of these two oscillators were then interpolated. There were user-adjustable parameters for the amplitude, frequency and waveform of each grain, with the waveform being determined by the extent of the interpolation between the sine wave and the band limited pulse. Roads' instrument was capable of producing 1600 grains per second.

Roads implemented higher level systems of control, which he referred to as events, to allow the composer to control the evolution of the grain streams. The composer could control the beginning time, grain duration (up to twenty

milliseconds), initial waveform, waveform rate of change (between sine and band-limited pulse), initial centre frequency and frequency slope, initial bandwidth and bandwidth slope, initial amplitude and amplitude slope, and grain density. This hierarchical structuring of control is still relevant today and has been included in the granular synthesis environment created for this project.

Roads revised his instrument in 1981 at the MIT Experimental Music Studio using Music 11 running on a DEC PDP-11/50 computer. Music 11 was developed by Barry Vercoe at MIT and was the direct predecessor of the widely used C-Sound program. It is interesting to note that Cycling 74's Max could be considered to be an indirect descendant of the Music-N family of languages and that the Max-based granular synthesis environment created for this project is therefore a distant relation, both in terms of architecture and programming environment, to Roads' early systems.

### **Real time granulation of soundfiles – *Riverrun***

In 1986, Barry Truax released *Riverrun* (Truax, 1988). This was the first piece to be generated using real time granulation techniques. Truax used a DMX – 1000 digital signal processor which allowed a maximum grain density of 2375 grains per second. The original piece was octophonic with four simultaneous stereo channels comprised of up to 32 individual tracks. As in his other earlier works, Truax made use of global control parameters to ramp values for the various synthesis parameters. Two of the compositions in the portfolio, *With Time not In Time* and *Interventions*, incorporate real time granulation of live input streams as buffered sound, while all of the remaining compositions use real time granulation of pre-recorded sound files. In this sense, the compositions are very much an extension of Truax's early examples of real time granulation. They differ from Truax's early work on real time granulation, however, in that the real time granulations are capable of being processed during a performance of the compositions and the granulations are presented together with their source sounds.

### **More recent examples of granulation in mixed compositions**

A more recent example of the use of granular synthesis in the context of mixed compositions can be found in Di Scipio (Di Scipio, 1996). Di Scipio is here concerned with the ways in which sound can be manipulated or composed on the scale of micro events in order to give rise to high-level structural properties. Di Scipio is also concerned with interactivity, not only in the context of performance but also in the context of composition. Di Scipio also makes use of a process referred to as recursive granular synthesis. This is a three-step process where a sound file is firstly submitted to granular time shifting and then elements of the processed sound file are then reordered. Finally, the new sound file is again submitted to the granular time shifting process. The ways in which high level structures emerge from low level events in Di Scipio's work contrasts with the compositions in this portfolio, where the approach tends more towards a top down model. These issues are discussed more fully in more detail in Chapter 3.

Harley also discusses real-time granular processing of sound in mixed compositions (Harley J. , 1999). Harley proposed the use of compositional algorithms as a solution to the problem of integrating instruments with electronic sounds. The process of granular synthesis is extended from the electroacoustic into the acoustic part by a metaphorical extension of parameters of granular synthesis and by applying the same generative algorithms to both parts. In this way Harley proposes that an "underlying identity of design" (Harley J. , 1999, p. 230) connects each part and affords a structural cohesion to the work. For Harley this is one way of "overcoming the problems inherent to the medium of instrumental electroacoustics". Harley's use compositional algorithms differs from the approach taken for the compositions in this portfolio, where the emphasis is more on the creation of perceptual continua to build connections between the acoustic and the electroacoustic.

Jean-Claude Risset's composition *Attracteurs étranges* (1988) for clarinet and tape used Gabor grains to create transformations of pre-recorded clarinet parts

(Roads 2001). The soloist enters into a dialogue with the tape part, which at time echoes and at times contrast with the live clarinet (IRCAM, 2016).

JoAnn Kuchera Morin typically uses extreme time stretching or time contraction to build new textures from instrumental sounds (Roads, Microsound, 2001).

Philippe Schoeller uses an “acoustic pixel” technique in his work *Feuillages* (1992) for fourteen instruments and eight channels of electronic sound. The “acoustic pixels” involve multiple streams of overlapping grains, which are then filtered to create a liquid quality (Roads, Microsound, 2001).

Sohrab Uduman’s composition, *Tracing Metamorphoses* (2001) for string quartet and electronics uses granular synthesis in conjunction with harmonisers and ring modulators to resonate and react to the acoustic material from the string quartet. Uduman’s intention was to work with the harmonic material of the quartet and find ways of traversing that material through the electronics. Uduman identifies two types of elaborations in the acoustic part: lines which thicken harmonically before dissipating into short, non sustaining gestures, and sustained, more textural material where the electronic transformations come to the fore, taking over from the acoustic material. Uduman uses resonances to pick out and sustain formants and to filter the acoustic part in unpredictable ways within defined limits. Uduman thus uses the electronics in the piece primarily to thicken and then dissipate the harmonies in the acoustic part. The electronic part is notated simply through the use of cue numbers. There is not indication on the score as to what the processing may be or how the resulting textures may sound.

## Chapter 2: Definition of Microsound and The Compositional Affordances of Microsound

In the context of this commentary, the term “microsound” is used to refer to an approach to composition that makes creative use of granular synthesis and other FFT based windowing techniques. Thompson defines microsound as “...more than a technique, microsound is an approach to composition which places emphasis on extremely brief time scales as well as an integration of this micro-time level with the time levels of sound gestures, sections, movements and whole pieces”. (Thompson, 2004, p. 207). This is broadly the definition that will be followed in this commentary. Complex evolving sound spectra are constructed out of streams or clouds of sonic particles of very small durations, typically 100ms or less, although grain sizes larger than 100ms are also possible. Larger grain sizes preserve more of the acoustic spectra of the source material while shorter grain sizes tend towards wide band impulses of noise. Larger grain sizes can be combined with shorter grains to produce a wide variety of sonic possibilities and relationships to the original material. These new spectra can then be further manipulated with other electronic processes to create an elaborate network of different relationships with the source material. The portfolio composition *Earth White Fracture* is one example of a composition where the grain size has been interpolated from a relatively short duration to a relatively long duration and back over the course of the piece.

Because of the nature of the process, environments for generating and manipulating microsound output a very large number of sonic events and this can lead to potentially very complex control networks. The granular synthesis environment used for the majority of compositions in the portfolio, for example, consists of three independent 16-voice granular synthesisers. If all three granular synthesisers are functioning with a grain size of 10ms, then (ignoring any limitations imposed by the signal vector size or the input/output buffer of the software environment) the resulting output would consist of 4800 grains per second. Through careful mapping of the user interface to the sound-producing engine of the software, however, the manipulation of a relatively small number

of parameters can produce a huge variety of different sonic possibilities. The parameters which have been found to have the most relevant effects on the output of the environment for the purposes of this portfolio are:

- Grain size – the length of a single sonic particle
- Grain density – the number of grains per second
- Playback speed – the speed at which the software reads through the granulated soundfile to produce time stretching of time compressing effects. Playback speed can also be reversed or set to zero in order to “freeze” the sound
- Jitter – a variable offset of the onset time of each grain which can be manipulated to make playback of the source material progressively less linear
- Number of voices – number of simultaneous grain streams produced by a single granular synthesiser. These streams may be simultaneous or they may be overlapping depending on settings for jitter
- Number of channels – the number of independent environments for granular synthesis happening at one time. The majority of the compositions in this commentary use an environment with three granular synthesisers. This was felt to be an acceptable compromise between compositional affordances and limitations imposed by computer processing power. Each environment may use the same source material or the source material may be different to produce a variety of results.
- Relative balance of channels – controlling the relative amplitudes of the three different environments can have a significant effect on the output as contrasting spectra fade in and out.
- Post granular processing – the way in which the output of the granular synthesiser is processed, if it is processed at all, will of course have a considerable influence on the resulting sonic spectra and its relationship to the source material. It is important, therefore, that there are good aesthetic reasons for including any post granular processing and that these are sympathetic to the overall aesthetics of the composition.

The choice of window function also has an audible effect on the output but although the software includes an option to change the window function, this has generally been left as a fixed value in the compositions in this portfolio. The cosine function was the least likely to introduce unwanted artefacts into the sound and so this was chosen as the default envelope for the compositions in the portfolio.

Most of the parameters described above can be set to static values, or they can be interpolated between different values. How these parameters have been mapped to the audio engine of the environment, and how they have been made available to the composer or the performer, are discussed in the sections on affordances and constraint, and interface design.

Through careful manipulation of the above parameters, the environment for granular synthesis is capable of producing an enormous variety of rich and evolving sonic landscapes. Progressive application of the parameters can result in the source material appearing in the output as an electronic facsimile of the original acoustic input at one end of a continuum and as wholly new material with little or no perceptual relationship to the original at the other end. Along this continuum, different aspects of the source material can be revealed or hidden in the output. The original material can be dramatically slowed down in order to reveal previously hidden detail, for example. Or the overall gestural shape of a sound can be preserved while dramatically changing its spectral content. Gestural sounds can quickly transform into textural sounds and back again. Sounds can appear to “dissolve” through careful manipulation of grain density. The portfolio composition *Thin Red Vein*, for example, contains instances of gestural surrogacy and framing and *Earth White Fracture* uses microsound to give an effect of suspended time. These are just some of the many compositional possibilities and relationships which are discussed in this commentary and explored in the portfolio.

It is an assertion of this thesis that juxtaposing the output of the granular environment with the original acoustic material is a musically rich and

aesthetically cohesive approach to composition. Microsound is, however, essentially a texture-based approach and as such typically does not conform to the aesthetics, traditions and performance practices of note-based music. The portfolio of compositions, however, demonstrates how microsound can be used as a compositional device which extends and compliments the output of the acoustic instruments.

In the context of this commentary microsound is considered as more of an approach to composition than as a genre or a single technique. The emphasis is always on composing with sonic material built on a variety of time levels. Implicit in any composition which uses microsound as the primary structuring principle is an approach to time that permits the coexistence of sounds as they unfold on different time scales. Micro-events are built into gestures and textures that are then further developed into longer phrases, sections and entire compositions. In this context definitions of gesture and texture broadly follow Smalley's definitions, where a gesture implies some form of energy-motion trajectory, spectral and morphological change, linearity and narrative and a texture is a sound which evolves, if it evolves at all, on a more worldly or environmental scale and where internal activity is more important than forward impetus (Smalley, 1997). Gestures and textures exist along a continuum and it is not always clear where the distinction is to be drawn between them. These micro-events can co-exist and contrast with sounds derived from other sources such as note based events from acoustic instruments, synthesised sounds, concrete sounds from field recordings or other sound objects. These sounds can themselves be further broken down into micro-events, transformed and re-contextualised. Microsound is therefore a powerful tool for juxtaposing the recognisable with the unrecognisable or to create a continuum from the possible to the impossible. Sounds can be divorced from their usual contexts and reframed with transformed versions of themselves.

Microsound is a particularly powerful technique for playing with source identity and context as it can act as a bridge between the real and the surreal, or sounds which are perceived to be physically possible and sounds which are perceived to

be physically impossible. When combined with other electronic techniques it becomes a very fluid environment for re-contextualising sonic events. Beyond its classic use as an “acoustic microscope”, microsound is also a very effective means of exploring tensions and contradictions as sounds transform from the real to the imaginary, again in the sense of perceived physical possibility and impossibility, ambiguities and contradictions arise as gestures become textures and causal relationships break down. Connections are broken and sound objects are repositioned in new contexts.

It is a contention of this commentary that microsound can be used as an effective organising principle when combined with acoustic instruments in mixed compositions. Microsound can function as a bridge between very different traditions of electroacoustic and acoustic music. The portfolio of compositions demonstrates how the seemingly contradictory traditions and performance practices of post serial, pitch-based writing for acoustic instruments can be productively combined with a texture-led electroacoustic approach using microsound as a unifying factor. The following sections of the commentary discuss the issues involved in the context of the individual compositions.

### **Chapter 3: Composition for Flute, Bass Clarinet, Piano and Electronics – *The Sea Turns Sand to Stone*. Structure and Form, Notation and Extended Techniques in the Context of Microsound**

This section of the commentary examines issues relating to structure and form, notation, and extended instrumental techniques when composing for acoustic instruments with microsound. These are examined in the context of the portfolio composition for flute, bass clarinet, piano and electronics: *The Sea Turns Sand to Stone* (winner of the William Mathias composition prize, Bangor New Music Festival 2015).

#### **Structure and form in *The Sea Turns Sand to Stone***

A principal aim of the composition is to explore issues of structure and form in music for acoustic instruments with live electronics. These are focused on the following research questions: firstly, how can microsound be used as part of an organising principle in order to provide an aesthetically satisfactory sense of cohesion between the acoustic and the electroacoustic elements? Secondly: how can microsound be used to develop and control both small scale and large scale structural and formal relationships between different aspects of the composition? In order to answer these questions satisfactorily it is first necessary to outline the issues raised when considering the problem of form in music, particularly in the context of mixed acoustic music and acousmatic music.

When discussing form it is important to draw a distinction between form as a concept and the various manifestations of that concept, such as sonata form, binary form etc., which have emerged historically through the analysis of different compositional practices. One definition of form as a concept is that it is the “...constructive or organising element in music” (Whittall, 2008). Another way of stating this could be that form is the way in which the smaller microstructural elements of a composition are grouped together to create an overall macrostructure. The distinction becomes problematic, however, when we consider the criteria a composer may be using, explicitly or implicitly, when ordering the material of a composition.

A composer may be choosing from perhaps three different approaches when imposing form on compositional material: a top-down schema led model, a bottom-up material led model and a generative or process-led model. Within those broad categories there exists the possibility of a great number of different approaches that combine ideas from each area as appropriate to a particular circumstance. The aesthetic reasons for choosing one particular approach to form over another are not always clear, however, and may be influenced by issues of genre conformity or historical precedent in ways which may not always be sympathetic to the compositional material.

Justifying compositional choices becomes even more complicated when we consider that form is not usually an isolated aspect of the composition but has an intimate relationship to the material of the composition (there may be exceptions to this: John Cage's *Imaginary Landscape No 5* is one of many examples of a composition where it could be argued that the form is imposed on the work in a highly prescriptive manner by the composer but the content, the musical material which inhabits the form, is left to what are essentially aleatoric processes). This becomes even more problematic when we consider that there is often a somewhat circular relationship between generalisations about form and the application of formal models by composers. Formal templates and approaches to form are extracted from compositions identified as typical or exemplary in some way and these models are then often used as examples of best practice and followed by other composers. Di Scipio (1995) (1994) Collins (2009) and Whittall (2008) provide further discussion of these ideas.

Any act of composition can also be viewed as an actualisation of a *theory* of form, even if that theory is not explicitly stated, and even if the composer is not aware of the formal implications of his or her choices. In a top-down approach composers may adopt formal templates for their compositions, which may be adaptations of existing templates or may be novel templates specific to that composer or composition. Di Scipio (1995) makes the point that in a top-down approach, the form of a composition pre-exists the composition, independent of

the material of the composition, not only in the mind of the composer but also in the minds of the listeners as well. The composition exists as an externally conditioned idea which must be recreated in a new context. For Di Scipio the form of the composition represents a mental *solution space* which *affords* certain actions. Di Scipio develops this idea further by stating that the composer can choose not only from the range of afforded actions but also from suggested extensions to what is explicitly afforded by the solution space. In the context of this idea, it is interesting to note that the history of the development of music technology, and by extension the history of electronic music, contains countless examples of this feedback loop where artists use technology in ways not immediately suggested by the affordances of the process or environment, and this leads to technical innovations which themselves suggest new unforeseen affordances. The history of the development of form is also driven by similar feedback loops where existing solution spaces suggest new affordances which themselves become established practices. The way in which Saariaho's approach to form, discussed later in this section, has been adapted and applied to the portfolio composition *The Sea Turns Sand To Stone* could be seen as an example of this process.

In a bottom-up approach to composition composers may allow the small-scale structural elements of a composition to dictate the macrostructures. In such cases a composer may use very strong rules or clearly defined criteria which govern the development of the material. There may be a very strong crossover with, or the process may be identical to, process or rule-based composition. In generative or process music, the form is governed by the underlying processes embedded into an associated compositional system. In its purest form, once the rules of the system have been established, the compositional processes then dictate the nature of the material and the form of the overall composition, often with little or no further intervention from the composer – the material is accepted as the inevitable outcome of the process. The act of composition may also become an act of curation, where the composer selects phrase level or larger scale material output by the process in order to assemble the final work.

It is not always so clear, however, what criteria a composer may be using when selecting material for a composition. If the underlying criteria which determine the choice of compositional material are not explicitly recognised by the composer during the production of a composition then it follows that they are also unknown to the listener during the reception of a composition. Thus in an entirely rule-based process the listener may or may not be aware of the underlying processes which ultimately determine the form of the work and knowledge of such processes is rarely a prerequisite for listening. In both cases, however, both composers and listeners feel entitled to make judgements as to the degree to which a composition has been successful. As a consequence it is necessary to consider the criteria a listening community may be using to make such judgements.

Emmerson (1989) proposes a model of composition which addresses the issue of what criteria composers and listeners may be using when they evaluate a work. The model is shown in Figure 2. In Emmerson's model the compositional process begins with an action, the production of sonic material, which is then tested or evaluated as being suitable or unsuitable for inclusion in the composition. If the material is unsuitable then it is either rejected or modified. The modified material then either becomes a new action or is stored in a repertoire of new actions for future use. The question, then, is what is the nature of the test used by the composer to accept or reject the material? In such cases it may seem that composers are unconsciously imposing their own aesthetic prejudices and conditioning onto the material. For Emmerson, however, it is the existence of the action repertoire that forms the basis of the test by which the sonic material is assessed. The exact nature of the test must remain elusive, (it is "unanalysable" in Emmerson's words (1989, p. 143)), but the important point is that the action repertoire is not the private property of the composer but that it is open to a community of interest made up of composers, performers and listeners whose views are trusted and valued and who collectively decide what kind of material may be included in the action repertoire.

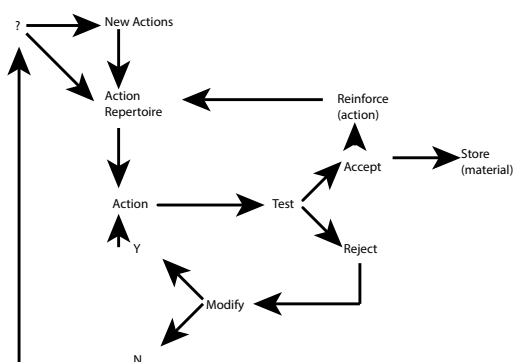

**Figure 2: Emerson's model of composition: adapted from (Emmerson, Composing Strategies and Pedagogy, 1989)**

For Di Scipio (1994) the shift from a top-down, example based approach to form to a bottom-up, rule based approach is a shift from an externally conditioned, analysis based idea of form to an idea of form based on an awareness of compositional processes. Whereas in a top down approach the form pre-exists the work, in a bottom up approach the form emerges from an explicitly designed process and manifests itself as an epiphenomenon of some underlying structure. In electroacoustic music, a natural endpoint of a bottom-up approach is that it can be the sounds themselves that are composed through the application of rules to various synthesis processes. Sound spectra cease to function as material to fill emerging structures and instead become the structuring principle behind the composition. Spectral morphologies replace an instrumental approach to composition and thus end the dualism between form and material, between container and contents (see also (Emmerson, 1986) for a further discussion of these ideas). In mixed compositions, however, the problem then becomes how to unite a dualistic, content and material, approach to form with a texture centred, morphological approach.

It is of course possible, and indeed common, to combine the three broad approaches to form outlined in the previous paragraphs – top-down schema driven, bottom-up material driven and generative, process-driven – in order to produce a complex, multifaceted set of interrelationships among the materials of

a composition which result in the final form of the piece. Mixed compositions, however, typically combine two very different traditions and approaches to form. In the following section, we will consider ways in which microsound as a process, as well as the affordances of microsound, can be applied as organising principles when considering form in mixed compositions. To begin with, however, it is necessary to consider why mixed compositions are particularly problematic as well as how the acoustic part and the electroacoustic part relate to each other. From this it will be possible to explore ways in which microsound can be used as a process for bridging the two traditions.

A significant problem to overcome when considering issues of form specifically in relation to instrumental music with electronics is that mixed compositions combine the languages and performance practices of two often very different traditions. This is not a situation unique to mixed compositions, of course, but the issue is particularly pronounced in this case as the approaches of the different traditions often appear to contradict each other. The challenge is to find a satisfactory way to make these differences coexist.

The acoustic parts and the electroacoustic parts of a composition can relate to each other in a number of different ways. The two parts engage in a complex and shifting network of relationships in which each part may be equal, or one part may dominate the other. These relationships can also of course change during the course of the composition. Outlining these relationships can help to identify compositional strategies that can then be used to create structure and cohesion in a work. An understanding of these relationships can also be used to show how microsound can function as a compositional tool to reinforce or subvert relationships between the parts. Emmerson (1998) uses case studies to explore the ways in which the acoustic related to the electroacoustic. Some of the ways in which the acoustic part and the electroacoustic part can relate to each other are outlined below.

The acoustic part and the electroacoustic part can be in a state of conflict or coexistence. There can be transitional or morphological relationships where

events can be perceived to have their origins in one sound world before moving to the other. There can be causal relationships where events in one sound world can be perceived as causing events in the other. There can be gestural/textural relationships which can manifest themselves through framing, layering or montage. There can be mimetic relationships where musical or extra musical relationships can emerge between the different sound worlds. There are also spatial relationships between the acoustic and the electroacoustic part. We now consider some of these relationships in more detail before showing how they can influence form and be manipulated through microsound in mixed compositions.

One of the more fundamental ways in which the parts relate to each other is through spatial relationships. These relationships can be either literal, in the sense that a sound really is coming from a certain position or has been produced by a certain sounding body, or metaphorical, where a sense of space is suggested or implied through some process or psychoacoustic phenomenon. There are different categories of spatial relationships. These can be summarised as follows:

- Spatial relationships associated with movement (how is the sound perceived to be travelling in space?)
- Spatial relationships associated with position (where is the sound?)
- Spatial relationships associated with material (how big is the sounding body? What is it made of? How is it being excited? Etc.)
- Spatial relationships associated with environment (in what sort of space is the soundworld unfolding? Is it a real space, an impossible space, a changing space? Etc.).

Although the exploration of spatial relationships is not one of the compositional aims of *The Sea Turns Sand to Stone*, these relationships inevitably exist and there are tools embedded in the software environment that allow these relationships to be exploited: specifically the spectral delay effect, the frequency shifting effect, the delay modulation effect and the relative amplitude levels can all be manipulated to suggest different spatial relationships.

Typically, in a live performance of a mixed composition, the acoustic part will be anchored to a fixed position on a stage and the electroacoustic part will be diffused through an array of loudspeakers. Blending the two parts can be problematic, however, because of the way in which the sounds are transmitted. The electroacoustic part typically emanates from directional speakers whereas the acoustic part will be produced by instruments which radiate sounds in much more complex patterns (Tremblay & McLaughlin, 2009).

When developing models of form for music with mixed acoustic and electroacoustic elements, it is useful to identify a principle of internal cohesion to act as an organising principle which will then unite the different sound worlds in a satisfactory manner. This is not necessarily straightforward, however, as the disciplines of acoustic and acousmatic music have complex and often contradictory relationships, particularly in the context of form and material. Di Scipio encapsulates these different approaches by making the distinction between composing *with* sound and composing sound (Di Scipio, 1998). In the first case the emphasis is on the relationships (gestural, tonal, dynamic etc.) that exist between the sounds and in the second case the emphasis is on the creation of the textures and timbres themselves and the relationships that unfold as those textures develop and interact.

In the first model, timbres are, at least to an extent, interchangeable. A phrase, for example, could be played on different instruments and still be recognisably the same. In the second model, timbre is the central focus of the composition: it is not possible to change the timbre without fundamentally changing the composition. With a great deal of crossover and a great many exceptions, acoustic instrumental music typically tends towards the first model whereas acousmatic music tends towards the second. Therein lie some interesting tensions but these potentially conflicting considerations need to be handled carefully. Models which combine both approaches, however, are only really satisfactory if there is a model of interaction, explicitly stated or implicit in the tradition, which unites the seemingly disparate electronic and acoustic parts.

One model that has been extremely successful in the structuring of instrumental music has been that of functional tonal harmony. In this model harmonic relationships are based on hierarchies of perceived levels of stability as sounds progress through degrees of consonance and dissonance. The Finnish composer Kajia Saariaho has borrowed the ideas of consonance and dissonance from the language of tonal harmony and used them to create new models for the structuring of texture based music (Saariaho, 1987). Saariaho's solution to the problem of combining the different sound worlds of the acoustic and the electroacoustic parts is to develop a sound/noise axis to unite the two elements. In Saariaho's model, the concepts of consonance and dissonance are replaced with concepts of pure tone and noise. This then becomes the organising principle behind some of her compositions. The axis allows her to create a logical timbral continuum which provides a pre-compositional framework where sounds can be placed on a theoretical hierarchical grid between pure sound, e.g. a periodic sound with few or no partials – a sine wave would be the ideal, and noise – complex, aperiodic spectrally dense sounds. In Saariaho's model, timbre takes the place of harmony with consonance being replaced by pure sound and dissonance being replaced by noise. Noisy, grainy textures take on the function of dissonance while smooth, fluid textures assume the role of consonance. The terms sensory consonance and sensory dissonance can be used to differentiate the use of the terms from their use in the context of tonal harmony.

O'Callaghan and Eigenfeldt provide a detailed examination of two of Saariaho's compositions for acoustic instruments and electronics which use this approach, namely *Verblendungen* (1984) and *Lichtbogen* (1986) (O'Callaghan & Eigenfeldt, 2010). Although the two pieces demonstrate different control strategies for the electronic part, *Verblendungen* uses a tape part whereas *Lichtbogen* uses live electronics featuring the processed sounds of the live instruments, they both use the same approach to sound in order to develop a structure. O'Callaghan and Eigenfeldt (2010) also propose a gesture focused analysis of the compositions. Their analysis reaffirms Saariaho's own writings where she discusses the use of extended instrumental techniques to create a continuum between noise and pure tone (Saariaho, 1987).

In the acoustic parts of *Verblendungen* and *Lichtbogen*, it is the spectral quality of the instrumental gestures used in the compositions that give form to the music. Extensive use is made of extended instrumental techniques in order to shift the gestures along the sound/noise axis. For O'Callaghan and Eigenfeldt gesture is defined as any perceptual unit or sound shape which develops over time. The use of the term to refer to a physical action that causes a sound is ignored. This is the definition that will be followed here. The variation of parameters over time can be thought of as giving "shape" to a sound and hence instigating a gesture (O'Callaghan & Eigenfeldt, 2010).

Saariaho's model can be easily adapted to compositions involving microsound. Indeed, granular synthesis functions as an excellent tool for shifting textures in both directions along a continuum from pure sound to noise. The composition *The Sea Turns Sand to Stone* uses Saariaho's model as the principal underlying framework upon which structure is developed. A significant difference, however, is that in the electroacoustic part, it is microsound that has been used to create the hierarchies of timbres from pure sound to noise. Saariaho's original hierarchy has also been extended to include other conceptual polarities that can exist along a continuum between consonance and dissonance (in the context of this discussion the terms consonance and dissonance are not used in their strict, tonal sense, but rather as terms which suggest states of stability and instability). These concepts are shown in Figure 3.

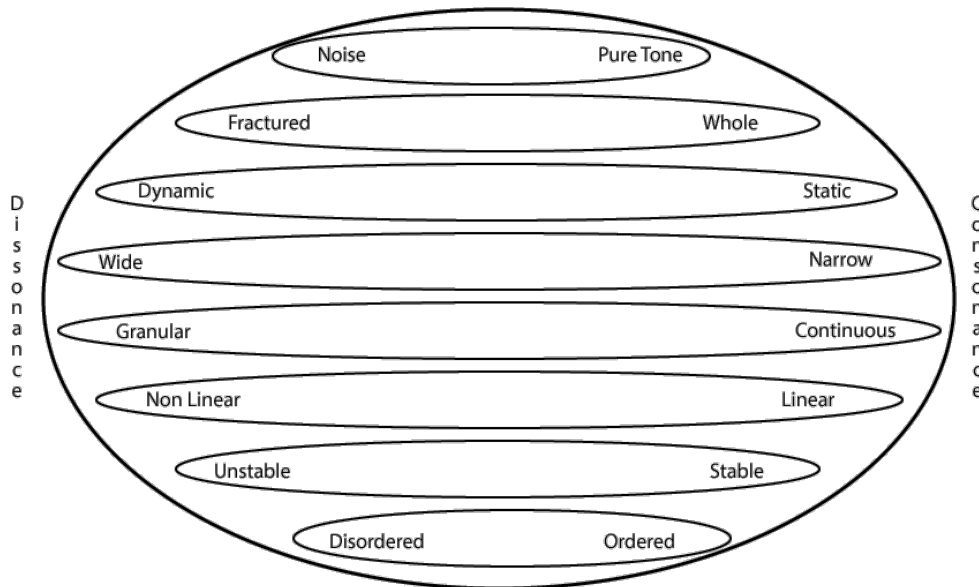

**Figure 3: Conceptual continuities between sensory dissonance and consonance (Source: author's own)**

Using these concepts as a guide, a schematic is created in which the acoustic part moves from a state of sensory dissonance towards a state of consonance, while the electronic part simultaneously moves in the opposite direction. The schematic is divided into seven sections. In each section the ratio between consonant material and dissonant material shifts until the last section, where the balance is effectively reversed. The overall length of the composition is set provisionally at 7'35" and 9 seconds is taken as a basic unit of time. The lengths of the different sections, as well as the relationships between sensory consonance and sensory dissonance are shown in Table 1. It is worth noting that the timings function as a compositional aid and they are not intended to be strictly adhered to during the performance. The actual length of the composition will vary from performance to performance, because the electroacoustic part is created in real time and triggered using cues in the software environment written into the score. The performers are free, therefore to react in a more natural way than if they were playing with fixed soundfiles. The actual length of the recording included with this portfolio is 10'12".

**Table 1: Temporal relationships between different sections in *The Sea Turns Sand to Stone***

Length of section	Ninth of section	Ratio Dissonance:Consonance	Ratio (secs)
36"	4	8:1	32:4
45"	5	7:2	35:10
54"	6	6:3	36:18
63"	7	5:4	35:28
72"	8	4:5	32:40
81"	9	3:6	27:54
90"	10	2:7	20:70

A schematic showing how these relationships apply to the overall structure of the composition is shown in Figure 4.

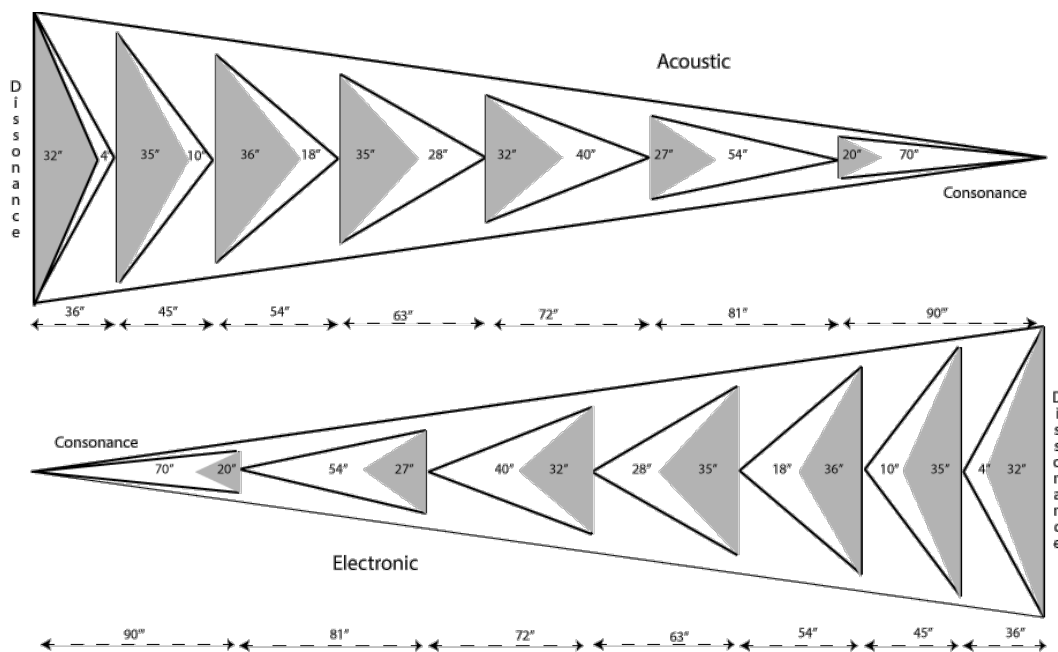

**Figure 4: A Schematic for *The Sea Turns Sand to Stone* showing morphologies between sensory consonance and dissonance. Microstructure is reflected in the macrostructure**

**The use of extended techniques to create perceptual continua between sensory “consonance” and “dissonance”**

For the acoustic part of the composition, a hierarchy of gestures has been created for each of the three instruments, starting with sounds that are perceived to be consonant and continuing through sounds which become

increasingly perceived as dissonant. Following Saariaho's model, extended instrumental techniques are used extensively in the composition in order to create a suitable range of gestures.

The hierarchy of gestures used by the bass clarinet in the composition are shown in Table 2.

**Table 2: Gestures used by the bass clarinet in *The Sea Turns Sand to Stone* ordered from sensory consonance to dissonance**

Low register
Senza Vibrato
Ord.
Molto Vibrato
Trills
Tremolo
High register
Slap tongue
Multiphonics
Tremolo between two multiphonics
Half embouchure
Morphing between air notes and half embouchure
Flutter tongue
Unpitched air notes

These instrumental gestures are then recorded as sound files and used as the basis for the electronic transformations. Examples of the gestures used by the bass clarinet are shown from **Figure 5** to **Figure 11** below.



**Figure 5: Bass clarinet F2 senza vibrato (Cue 1)**

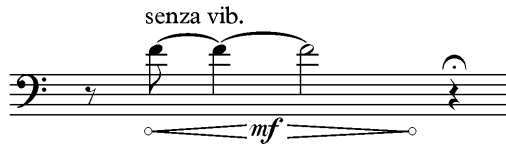

Figure 6: Bass Clarinet F2 senza vibrato (Cue 4)



Figure 7: Trill (Cue 7)

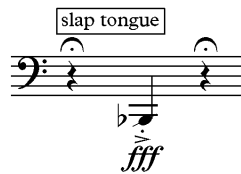

Figure 8: Bass clarinet slap tongue (Cue 10)

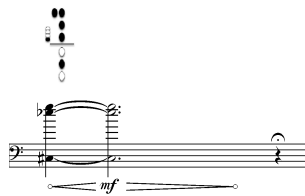

Figure 9: Bass clarinet multiphonic (Cue 13)

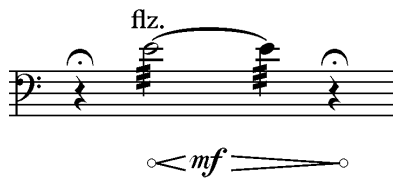

Figure 10: Bass Clarinet high flutter tongue (Cue 16)

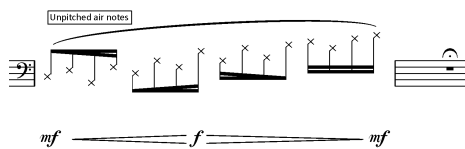

Figure 11: Bass Clarinet unpitched air notes (Cue 19)

Similar hierarchies of gestures are created for the piano and the flute. Table 3 shows the gestures used by the piano ordered from sensory consonance to dissonance.

**Table 3: Gestures used by the piano ordered from pure sound to noise**

Piano chord
Piano iterative gesture
Piano pushing agitated gesture
Piano low E flat 7 <sup>th</sup> harmonic
Piano harmonic then scraping gesture
Piano scraping gesture then harmonic
Piano slide bouncing off strings

Examples of the piano gestures used in the composition are shown in **Figure 12** to **Figure 18**.

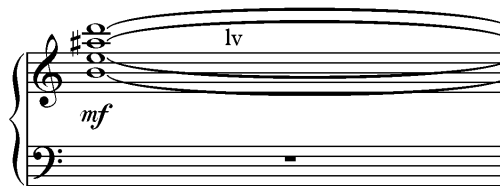

**Figure 12: Piano chord**

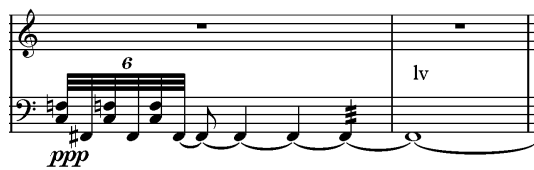

**Figure 13: Piano iterative gesture 1**

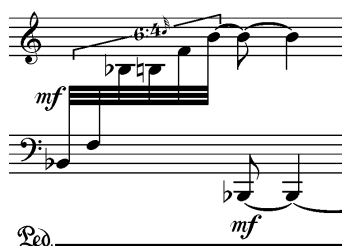

**Figure 14: Piano pushing agitated gesture**

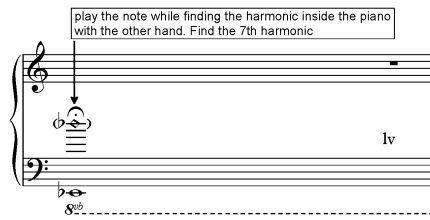

**Figure 15: Piano harmonic**

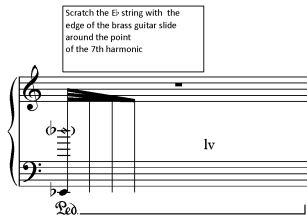

**Figure 16: Piano harmonic and scraping gesture**

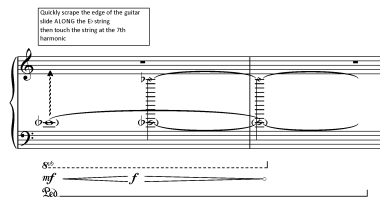

**Figure 17: Piano scraping gesture then harmonic**

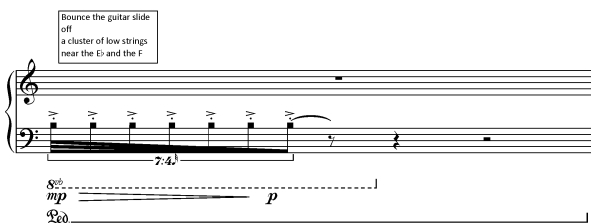

**Figure 18: Piano slide bouncing off strings**

Table 4 shows the gestures used by the flute in the composition.

**Table 4: Gestures used by the flute ordered from pure sound to noise**

Flute F4 senza vib
Flute F# 6 harmonic
Flute whistle tone F#6
Flute timbral trill

Flute tongue ram
Flute F#6 flutter tongue
Flute jet whistle

Examples of the flute gestures used in the composition are shown in Figure 19 to Figure 29.

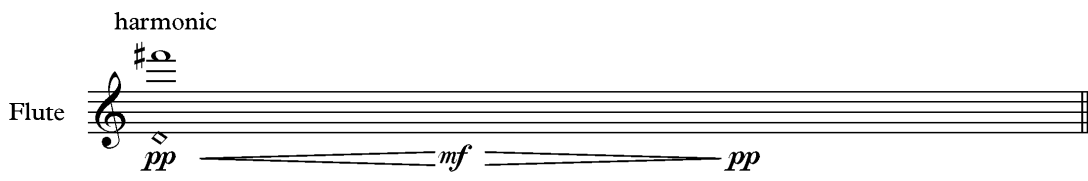

Figure 19: Flute F#6 harmonic (cue 6)

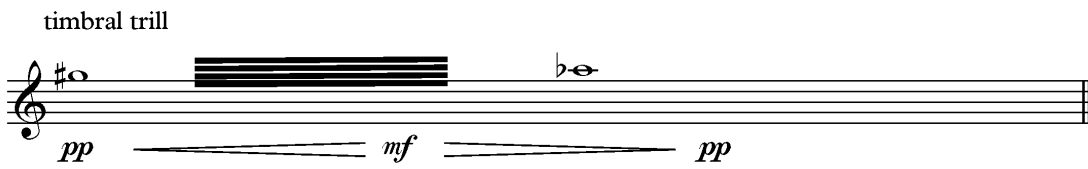

Figure 20: Flute timbral trill (cue 12)

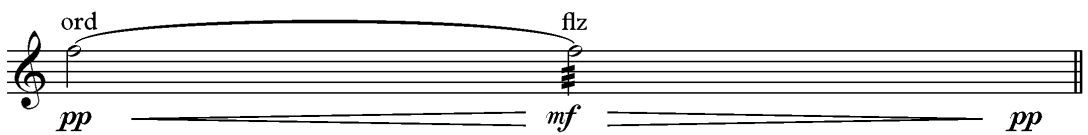

Figure 21: Flute ord to flz (cue 9)

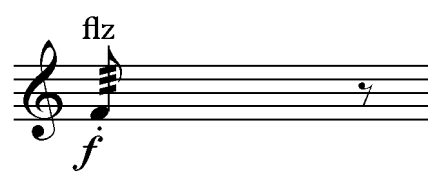

Figure 22: Flute short staccato flutter tongue



Figure 23: Flute senza vibrato (Cue 3)

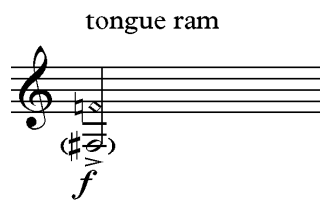

Figure 24: Flute tongue ram (cue 15)

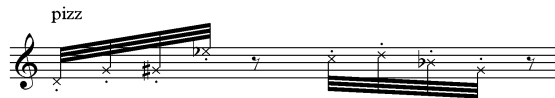

Figure 25: Flute pizz



Figure 26: Flute wind tone to ord.

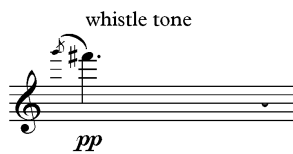

Figure 27: Flute whistle tone (Cue 9)

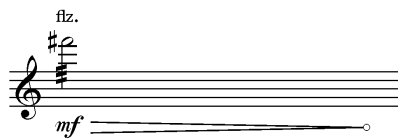

Figure 28: Flute high flutter tongue (Cue 18)

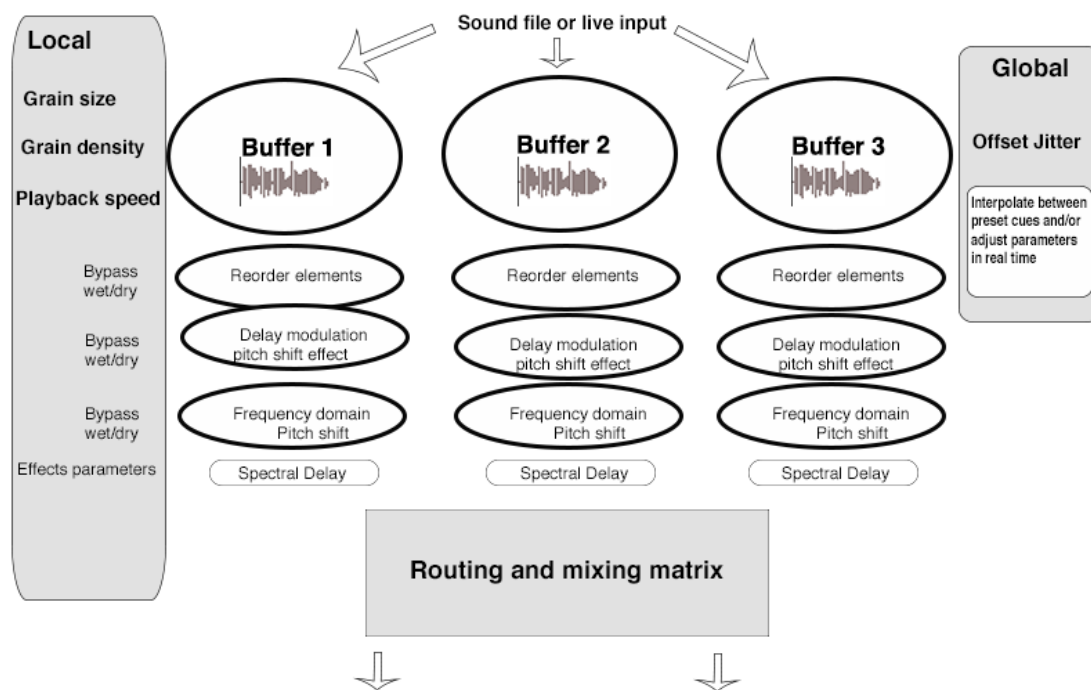

Figure 29: Flute jet whistle (cue 21)

The harmonic language used in *The Sea Turns Sand to Stone* emerges directly from the choice of material used for the gestural hierarchies.

## Mapping affordances from the microsound environment onto the sensory consonance/dissonance axis

Having established a hierarchy of gestures for the instruments in the acoustic part, the next step in the compositional process is to map electronic affordances in the performance environment onto the sensory consonance/dissonance axis. A broad overview of the environment for the electronic part is shown in Figure 30.



**Figure 30: Overview of the electronic performance environment**

The schematic in Figure 30 shows three identical channels, each starting with an independent 16-voice granular synthesiser. The output of each granular synthesiser then flows through four different processors. The first process allows the elements in the output of the granular synthesiser to be reordered. The second is a delay-based pitch shifting effect which can be used to introduce comb filtering and amplitude modulation artefacts into the sound. The third is an FFT based pitch shifter. The final effect in the chain is a spectral delay, which can be used either to give a sense of the sound inhabiting an acoustic environment,

or to emphasise and freeze certain frequencies in the spectrum of the sound. All of the processes after the granular synthesiser have balance controls so that the ratio of the processed to the unprocessed sounds can be adjusted.

Clearly, the performance environment for the electronics has a very large number of parameters. In the context of this composition it would be inappropriate to expect a performer of the electronic part to be able to control the electronics in any meaningful way without significantly redesigning the interface. Indeed, the large number of user adjustable parameters could even be seen as a restriction on creativity. This is because constraints in interface design are as important as affordances (there will be a fuller discussion of these issues in a later section). Creativity is often a result of what is not possible rather than what is possible. For this composition it would be more appropriate to allow a higher level control of the parameters where chains of events can be triggered globally by sending out multiple messages to trigger complex, carefully designed events. In this way, the benefits of having the flexibility afforded by many user adjustable parameters can be utilised without the disadvantages of an overwhelmingly complicated environment. A list of all the available parameters in the environment, together with a list of abbreviations used to send messages to those parameters in the Max environment, are given in Table 5.

**Table 5: User adjustable parameters, together with the abbreviations used to send messages to the parameters in the Max environment.**

<b>Abbreviation for messaging in Max</b>	<b>Parameter</b>
Fd1	Fade level 1 (0. – 90.)
Fdtime1	Fade time 1 (ms)
Fd2	Etc.
Fdtime2	
Fd3	
Fdtime3	
Pbs1	Playback speed 1 (1 = normal playback, 0.5 = half speed etc.)

Pbs1time etc	Interpolation time for play back speed 1
Pbs2	
Pbs3	
Gs1	Grain size 1 (ms)
Gs1time	Grain size interpolation time (ms)
Gs2	
Gs2time	
Gs3	
Gs3time	
Dns1	Grain density (ms )
Dns1time	Grain density interpolation time (ms)
Dns2	
Dns2time	
Dns3	
Dns3time	
Cue1	Replace sound file 1
Cue2	
Cue3	
Balancea1 etc.	Wet dry balance for channel (a -c) and slot (1 - 4)
Blctimea1 etc.	Interpolation time for wet dry balance
Crossfadea1 etc.	Crossfade for chucker effect
Cftimea1 etc.	Crossfade time for chucker effect
Pseta1 etc	Presets (4) for chucker effect patterns
Freqina2 etc	Frequency in for delay modulation pitch shift effect
Freqtimea2	Interpolation time for frequency
Delaywina2 etc	Delay window size for delay modulation effect
Delaywintimea2	Interpolation time for delay window size

Phasecompsa2 etc	Phase components for delay modulation effect
Phasecomptimea2	Interpolation time for phase components
Delaymodfeedbacka2 etc	Feedback for delay modulation effect
Delaymodfeedbacktimea2	Interpolation time for feedback
Desta3	Destination value in Hz for fft pitch shift
Ramptimea3	Interpolation time for fft pitch shift
changedelayA etc	Change delay shape for spectral delay (1 - 15)
changefilterA etc	Change filter shape for spectral delay (1 - 16)
Delaybang	Delay a bang to trigger messages
Delaybangtime	Set the time for delaybang
Delaybangroute	Route the delayed bang to the appropriate destination
Beginning1 etc	Return to beginning of sound file

Having three separate 16-voice granular synthesisers, each with its own independent effects routing, opens up many creative possibilities. For this composition each of the three channels is assigned to one of the three acoustic instruments. Then, using the schematic in Figure 4 and taking recordings of the instrumental gestures as source material, the electronic part for each of the seven sections of the composition is carefully pre-composed and mapped to cues in the Max environment. Detailed schematics of the electronic part are shown in Figure 31 to Figure 37.

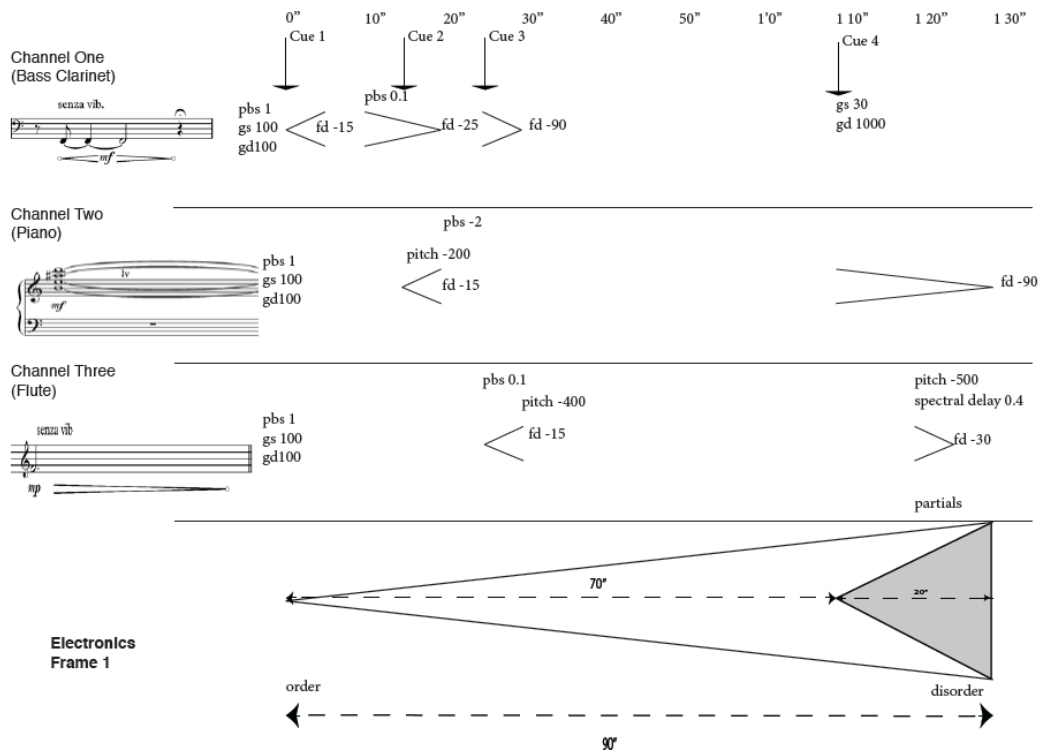

Figure 31: *The Sea Turns Sand to Stone* Electronics section 1

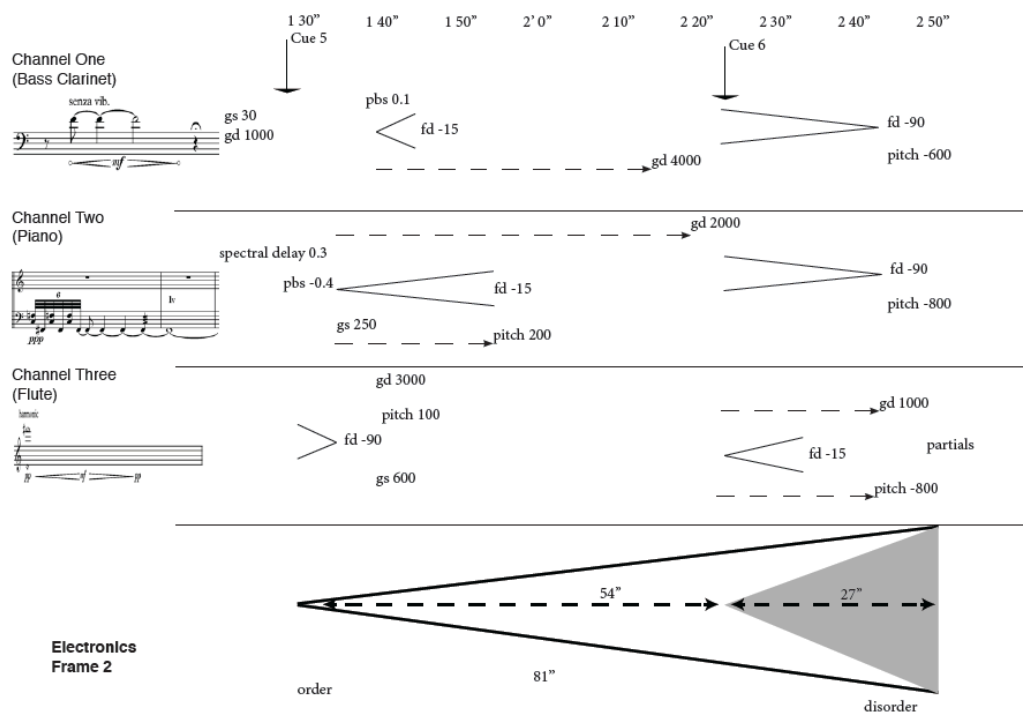

Figure 32: *The Sea Turns Sand to Stone* Electronics section 2

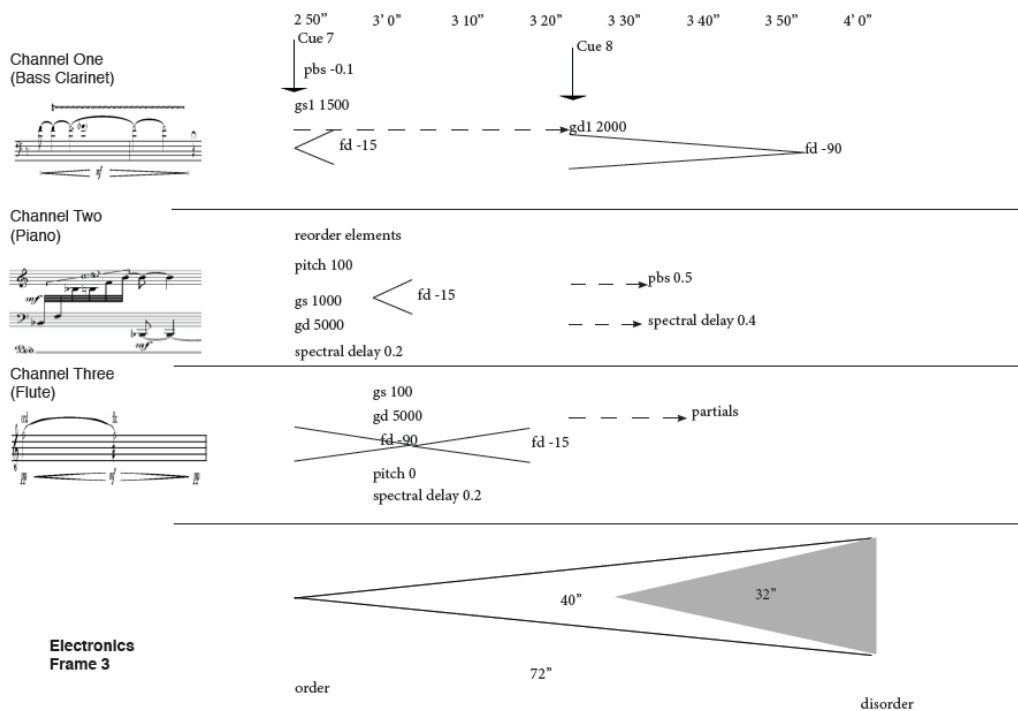

Figure 33: *The Sea Turns Sand to Stone* Electronics section 3

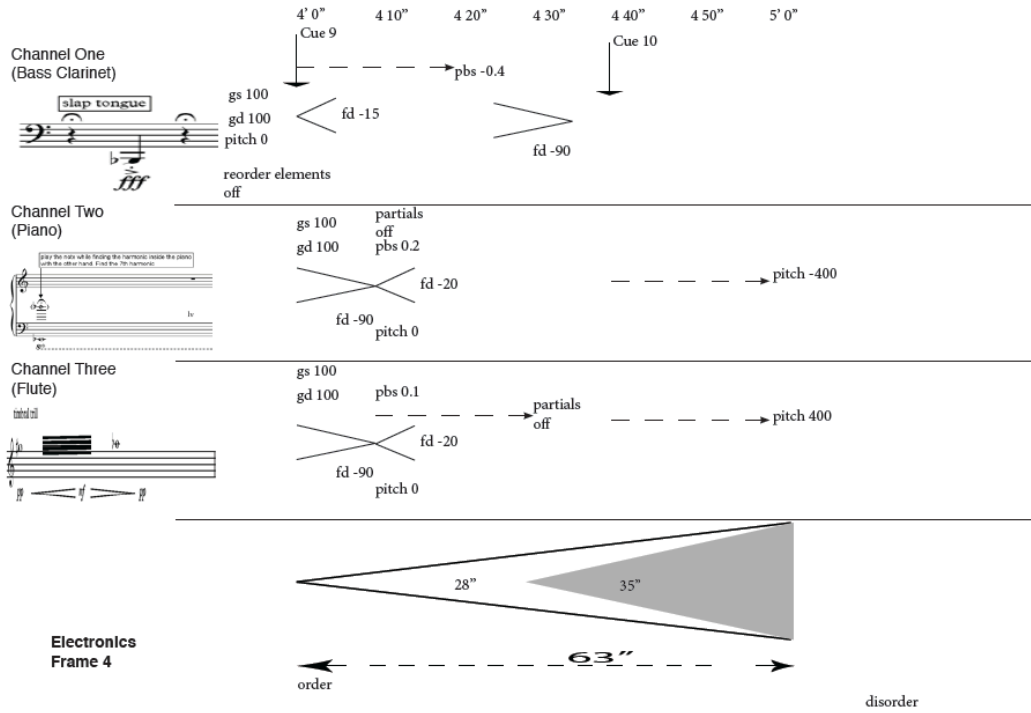

Figure 34: *The Sea Turns Sand to Stone* Electronics section 4

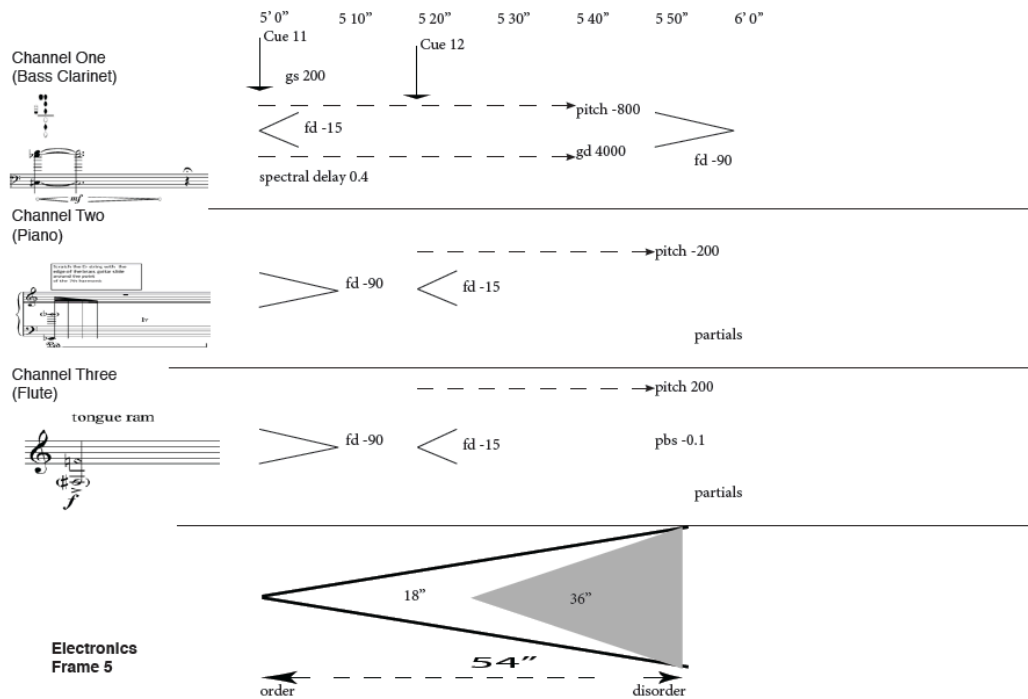

Figure 35: *The Sea Turns Sand to Stone* Electronics section 5

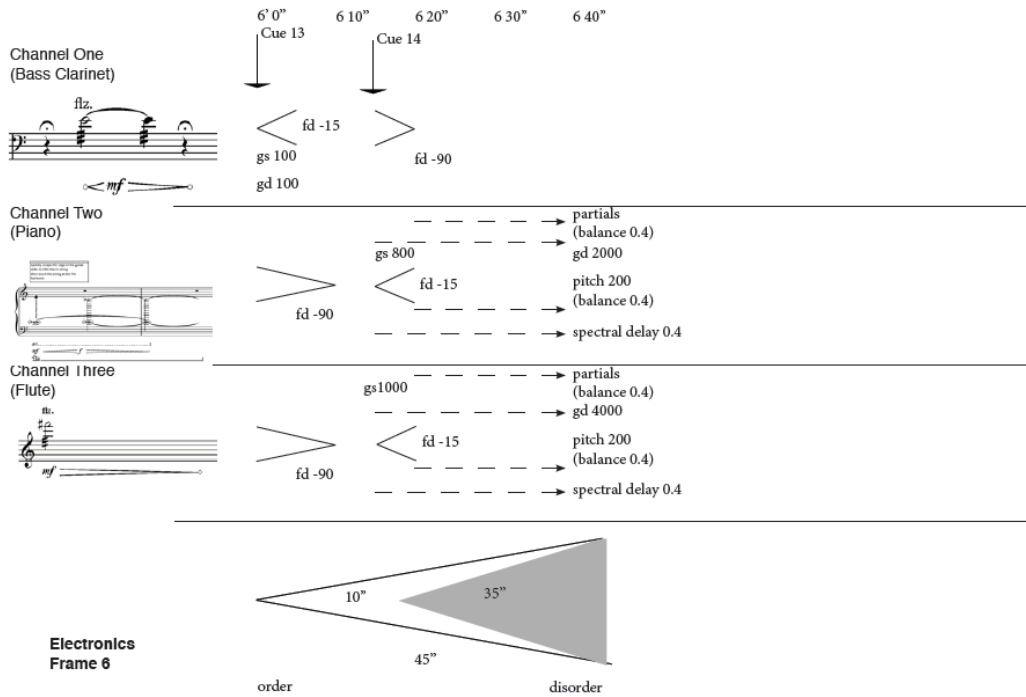

Figure 36: *The Sea Turns Sand to Stone* Electronics section 6

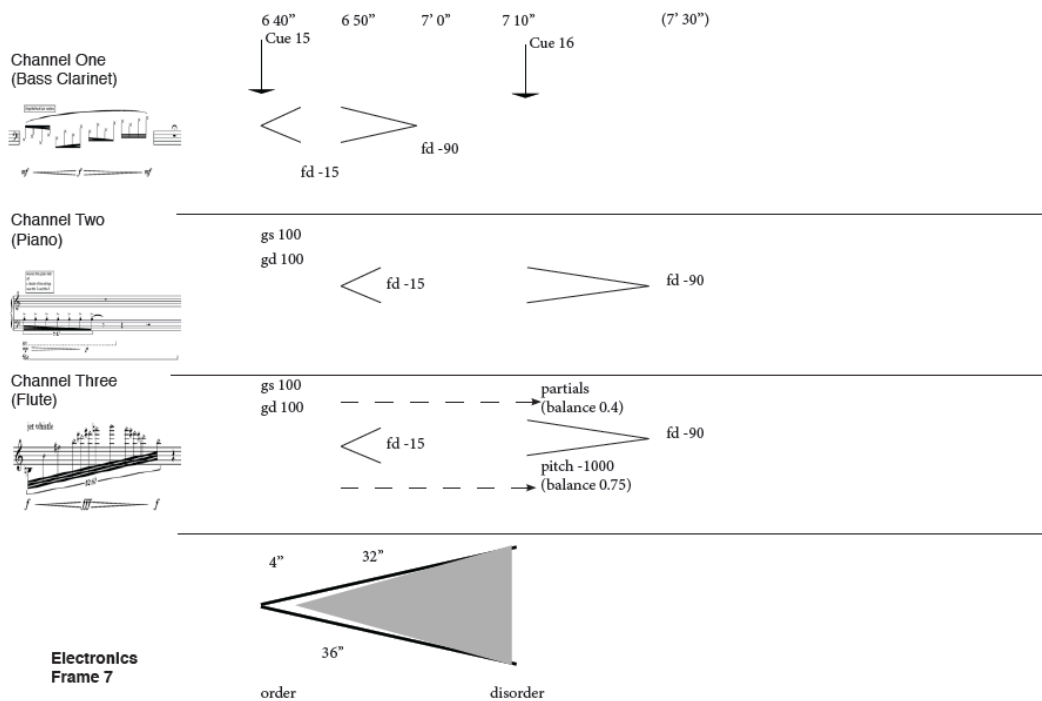

Figure 37: *The Sea Turns Sand to Stone* Electronics section 7

The source material for the electronic cues, therefore, has been chosen so that the instrumental gestures become increasingly dissonant as the composition progresses. The electronic processing is designed in such a way as to move the sounds increasingly further away from the recognisable instrumental gestures of the source material. At the same time, the acoustic part moves from a state of sensory dissonance and instability towards a state of sensory consonance and relative stasis. The electronic part, for example, begins with a clearly recognisable F2 played on the bass clarinet. This note is then time-stretched, beginning a gradual shift away from the source material which continues throughout the composition.

The schematics in Figure 31 to Figure 37 could be thought of as compositional scores or even, to a lesser extent, analysis scores, as they contain much of the information necessary to reproduce the electronic part of the composition. As performance scores, however, they are somewhat limited, precisely because they contain too much information and it would be difficult to incorporate them with the scores for the acoustic parts written in traditional Western notation. The next section discusses the issues involved when designing scores for acoustic instruments and electronics, particularly with regard to microsound. The section begins with a general discussion on the issues involved before addressing the specific issues raised by *The Sea Turns Sand to Stone* and an overview of the solutions that have been developed.

### **Notating the electronic part in *The Sea Turns Sand to Stone***

Scoring music for acoustic instruments and electronics raises a number of important issues and presents the composer with certain challenges, the solutions to which, if they exist at all, are not immediately apparent. The following issues have been regarded as particularly important:

- Is it really necessary to have a score for the electronic part?
- Are there any other models that could be implemented that do not involve a written score?
- What are the benefits of having an integrated score for acoustic instruments and the electronic part?

- How is scoring for electronic instruments different for scoring for traditional instruments?
- How should the score for the electronic part be represented? Should the score for the electronic part be purely prescriptive (i.e. instructional) or should it attempt to describe the sounds of the piece as well (i.e. be representative)?
- How much freedom for interaction should be embedded into the notation?
- Does the score allow the performer of the electronic part the same freedoms as the score for the acoustic instruments?
- In what ways does scoring the electronic part restrict or enhance the freedoms of the performers of the acoustic part?

In one idealised model, a composition scored for acoustic instruments with electronics, where the electronics are to be controlled by a human performer, the score would allow the performers of both parts the same freedoms they would experience if they were performing a piece of chamber music scored entirely using traditional Western music notation. The performer of the electronic part would be integrated into the ensemble to the same extent as the other musicians. In traditional notation the score acts as both a visual representation of the sound and a detailed prescription for how the piece is to be performed. Partly because of the effectiveness of the system, but also because of a familiarity with the tradition and performance practices from which it has evolved, a traditional score would be readily understood by the musicians involved. It would communicate the wishes of the composer quite clearly and would serve as an effective, if not indispensable, tool for both rehearsals and performance. This is because traditional Western notation is a highly effective system for scoring certain types of music. It is particularly effective at representing pitch and note duration. Tempo fluctuations and dynamics can also be represented but these can be more ambiguous. There are also conventions for representing standardised articulations. Increasingly these conventions include a growing number of extended instrumental techniques. Unfortunately such a utopia is very hard to achieve, and success or failure is very much context dependent.

The system is arguably at its least successful when conveying timbral information; unfortunately it is precisely this timbral information that tends to be the focus of much electroacoustic music. In mixed compositions, such as *The Sea Turns Sand to Stone*, it is thus necessary to find a meaningful way to combine traditional Western notation with a system that conveys timbral information with suitably communicative performance instructions within the same score. Such a score could then function both as a performance score and an analysis score. As mentioned above, the schematics shown in Figure 31 to Figure 37 could be thought of as detailed compositional or analysis scores and it would be possible to argue that they should be included as an appendix to the full score because they convey important information about the compositional process and the reproduction of the electronic part, which in turn potentially heightens the understanding of the performers as to the intended outcomes. They do not, however, contain any significant representation of the sounds. In this regard they fall short of traditional Western notation, where the score manages to represent both a set of instructions to a performer and, to an extent, a visual representation of the sounds produced. They are also difficult to read and the density and complexity of information provided can sometimes prove counter-productive. When designing the score for the electroacoustic part, it is important to consider the properties of traditional notation that make it so successful and to investigate if any of these properties are transferable to a score for the electronic part. The following section gives a brief overview of traditional notation, the reasons why it has been so successful and why, despite this, it is not always appropriate for acousmatic music incorporating microsound.

Traditional notation of Western music is a system that has been evolving for at least eleven centuries with its beginnings usually identified with the use of neumes for the notation of liturgical music in the monasteries of Europe in the ninth century. The present system of using five line staves was becoming widespread by the fifteenth century and it is a testament to its ongoing suitability that it remains the core environment for writing acoustic music to the present day.

The fact that traditional Western notation manages to be both descriptive and prescriptive is not the only reason for the enormous success of the system. It also has a flexibility that allows it to be used by different instruments with only minor modifications to take account of different ranges, performance techniques etc. This is because the notation system, the instruments, and the genres of music which the instruments play and the system notates, have all been evolving together over centuries to produce a unified and highly effective environment for the composition, performance and analysis of a certain approach of music. It is also because the representation of the sound takes primacy over the representation of the gesture, in contrast to the situation with most electronic instruments. Where there is a requirement to extend the associated notation near universal enhancements specific to the instruments concerned have been developed and successfully implemented in many different contexts.

Electroacoustic composition, by contrast, has a much more limited tradition to draw upon. It is a very young genre with its beginnings dating back only as far as the 1940s and the pioneering work of Pierre Schaeffer. For various practical and historical reasons, there has not been the same motivation to produce notated scores in fixed media electroacoustic composition. Where scores have been produced they have tended to be used for diffusion purposes or for study and analysis, and in the case of all-acousmatic works these are few and far between. In scores for mixed compositions a graphical representation of the electroacoustic part is often needed for synchronisation purposes: the performer of the acoustic part needs to be able to predict cues in the electroacoustic part. Even when this is the case, however, the graphical representation is often accompanied by a time line showing events in relation to minutes and seconds. Examples of scores for mixed media compositions which include a graphical representation of the electroacoustic part are *Bhakti* (1982) by Jonathan Harvey, *Lichtbogen* (1986) by Kaija Saariaho and *Clarinet Threads* (1985) by Denis Smalley. To a greater or lesser extent the Harvey and the Smalley scores also include elements of traditional notation in the electroacoustic part to act as cues for the performer of the acoustic part to follow. Figure 38 shows an excerpt from

the score of Stockhausen's *Mikrophonie I* (1966), which is an early example of a graphical score used for the realisation of live electronics.

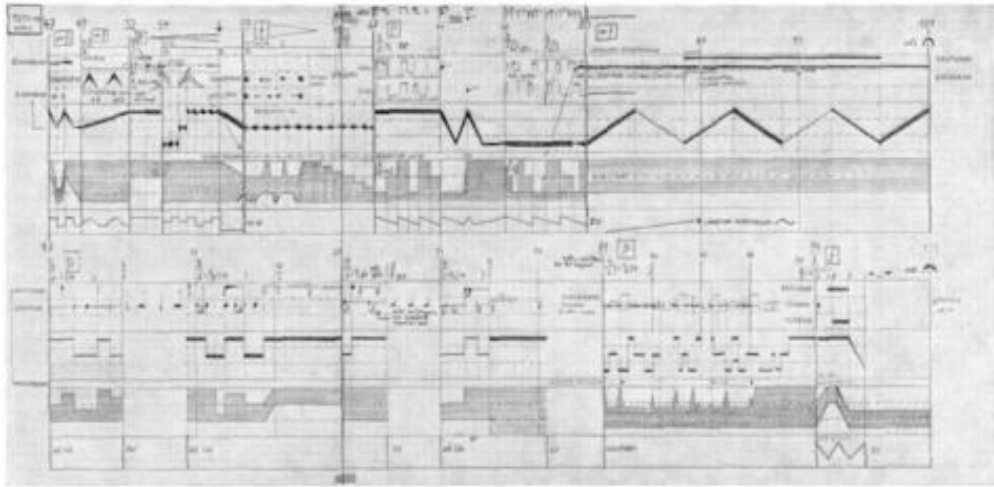

**Figure 38: *Mikrophonie I* (1966) Stockhausen. An example of an early graphical notational score for live electronics**

Some of the reasons why scores for electroacoustic music are used more for study or diffusion purposes are clear: fixed-media electroacoustic music has developed primarily as a timbre based genre which has typically been composed in a studio environment. Traditional Western notation is wholly inadequate at representing such music. It is not needed during the composition process, which usually consists of the collecting, editing, processing and arranging of sounds; nor is it essential during the performance, which typically involves the diffusion of pre-recorded material through a multichannel speaker system. Diffusion scores tend to be graphical in nature and there is no one common standard for how they should look. Representational scores also tend to be graphical and may also include technology-generated visualisations of the music such as sonograms. Much has been written on the classification of electroacoustic sound, notably by Schaeffer (Schaeffer, 1966) and Smalley (Smalley, 1997). These writings have led to some attempts to produce a useful notation system for the description and analysis of electroacoustic sound (e.g. (Patton, 2007) or (Thoresen, 2007)). Such systems, however, are generally intended for study and analysis rather than for performance.

However, fixed-media electroacoustic works are not the most useful precedents to consider in a discussion on scoring for acoustic instruments with live

electronics. Even when considering works for live electronics or other mixed media models there are fundamental differences between the nature of acoustic instruments and electronic instruments that make the emergence of a universal notation system unlikely. Tormey uses his experiences of working with the Princeton Laptop Orchestra to highlight some of the problems associated with scoring parts for electronic instruments when performing interactively (Tormey, 2011). He notes that many of the works composed for the Princeton Laptop Orchestra rely on improvisation, aleatoric systems or open form models. He attributes this to a lack of defined and effective paradigms within which to develop and communicate more strictly musical ideas.

One reason for this lack of paradigms is that scoring for electronic instruments returns us to the problems of designing suitable interfaces for electronic instruments. A fundamental difference between acoustic instruments and electronic instruments is that with electronic instruments correlations between gesture and sound are arbitrarily imposed by the instrument designer. In other words it is not possible to take a universal representative model as a starting point when designing scores for electronic instruments because there is no universal correlation between gesture, in the sense of an action carried out by a performer, and sound with electronic instruments. This lack of a stable relationship between gesture and sound means that scores for electronic instruments must signify physical input rather than sonic output. Furthermore, because of the potentially unlimited number of possible instruments (it is not untypical for instruments to be created specifically for one composition and then never used again in exactly the same form) it is not possible to devise a universal system of notation to capture all possible input gestures.

This does not mean, however, that it is not desirable to develop or follow paradigms which can be reused and applied as widely as practicable. It might thus be useful to identify a corpus of input gestures which could be given symbolic representation, but for reasons such as the following the constraints are significant. For example this approach is problematic because of the varied nature of possible input devices and corresponding possible gestures. Input

gestures can broadly be categorized as discrete events or continuous events. Both can be mapped to single or multiple destinations and can be used to trigger discrete or continuous parameter changes in a complex matrix of possibilities. Traditional notation's paradigm for representing time on the horizontal axis can be borrowed and applied to new notation systems and, for discrete events, the paradigm of using note heads on a line to represent onset time and duration can also be borrowed and adapted (in a manner that would have similarities to non-pitched percussion, for example). Vertical position would no longer represent pitch but could be mapped to whichever parameter was appropriate in the context of the instrument.

Continuous events are more problematic to notate but these too could borrow from traditional notation. Dynamic markings can be used to symbolize controller movements and, by combining multiple lines, even controller movements in more than one direction (e.g. xy pads, joystick movements etc) could be mapped. Tormey (2011) gives an example of this. A problem, of course, is that a performer would have to develop score reading skills specific to the particular instrument, although by making the notation as generic as possible there should be at least some degree of transferability. It is interesting to note that these problems are not exclusive to the electronic domain. Lachenmann, for example, has adapted common practice notation towards actions for extended techniques played by acoustic instruments.

Moving away from the printed notated score as a template opens up many more possibilities. An animated score presented on a screen removes the necessity of plotting time on one axis and allows the score to develop in real time. In this way controller data could be recorded by the composer and then played back to the performer, using whatever graphical representation seems most appropriate. The performer would then interpret the data but with the flexibility to adapt to performance variations. As long as there was a simple system to navigate the score in order to synchronize to the performance, this would combine the flexibility of a human performer with the accuracy of a score automated by the composer.

A number of instrumental works composed in the 20<sup>th</sup> and 21<sup>st</sup> centuries have been concerned specifically with exploration of timbre and as noted earlier this has in turn led to a growth in the repertoire of extended techniques for acoustic instruments. These techniques often embrace very particular notations which tend to be specific to individual instruments. They are usually incorporated into traditional notation as additional graphics, text-based instructions, or alternative note heads. Many standardisations are emerging for the notation of extended techniques and these are discussed more fully in the sections dealing with the notation of the acoustic material included in the composition folio. Notation of extended techniques provides a useful precedent and another potential model for the notation of the electronic part in that it is integrated into the score and merges with traditional notation in a way that makes it useful in a performance environment.

All of the methods described above should have the common aim of allowing the performer of the electronic part to be as unrestricted as possible by the mechanisms of performing on a computer. A well-designed score should reflect the affordances of an instrument, and should be relatively easy to read and implement. The composer should consider the relationships between the interface, the sound engine and the score from the very beginning of the composition process. When composing it is as important to be as familiar with the possibilities of an electronic instrument as it is when composing for acoustic instruments. These fundamental precepts underpin the repertoire of works composed for this submission.

One solution to the problem of notating input gestures is to limit the nature of those gestures by designing the interface of the instrument and mapping the affordances in such a way as to severely limit the range of gestures necessary to realise the score. This is the approach that has been taken in *The Sea Turns Sand to Stone*. In this composition the input gestures are reduced to a series of cues to be triggered by the performer of the electronic part as well as responsibility for ensuring that the balance of sounds between the acoustic and the electroacoustic

parts remains appropriate. This, of course, restricts the choices available to the performer of the electronic part. It is, however, precisely this limitation of choice that allows the composer much greater control over the material and allows the score to become a usable and useful prescription for the realisation of the piece.

With regard to the representational aspect of the score, one way to ensure that the score conveys the sounds of the electronic part in a meaningful way is to use graphics which give a broad representation of the main processes and draw the listener's attention to the most important processes. Although this approach could be criticised for the lack of detail which a full sonogram would display, it could also be argued that by reducing the score to only those processes focuses attention onto those processes which are deemed by the composer to be significant. With this in mind, a series of graphics were created which have been used in *The Sea Turns Sand to Stone* and other compositions in this portfolio and which aim to reduce the complexity of the schematics in Figure 31 to Figure 37 by representing the main electronic processes in a way that is both relatively intuitive to understand and easy to combine with the acoustic part while still remaining useful and meaningful. The graphics used in the score are shown in Figure 39 to Figure 50. These graphics have also been used in other compositions in the portfolio.

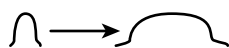

**Figure 39: Increase grain size**

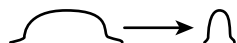

**Figure 40: Decrease grain size**



**Figure 41: Decrease grain density**



Figure 42: Increase grain density

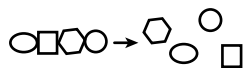

Figure 43: Reorder elements



Figure 44: Add partials (through comb filtering or amplitude modulation)

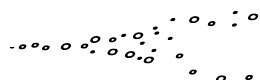

Figure 45: Gradually add partials



Figure 46: Shift frequency up



Figure 47: Shift frequency down

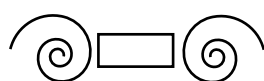
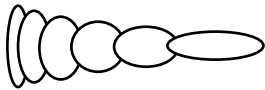
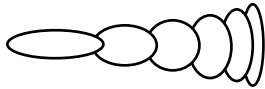

Figure 48: Spectral delay



**Figure 49: Time stretch**



**Figure 50: Time contraction**

An approach which combines traditional Western notation with a graphical approach has the advantage of allowing key structural elements in the electroacoustic part to be clearly identifiable to the composer, the performer and by extension also the listener.

When designing the graphics for the electronic part, it is necessary to ensure that the images chosen are appropriate for the task. For Stroppa a score is essentially a reduction of information which involves a knowledge of the materials involved, and a knowledge of the laws of the organisation of those materials. The score must also be notated in a way that is easily comprehensible. A composer then need only notate only those elements of the composition which must be presented in detail. Other elements can be presented in less detail, as their meaning is assumed, or left to the interpretation of the performer.

If a performer is provided with a readily accessible visual representation of how an electroacoustic event will sound, then the performer will better understand how their acoustic instrument relates to the digital instrument and by extension fits into the overall context of the composition (Patton, 2007). A well-designed descriptive notation system which integrates with traditional notation should therefore result in improved opportunities for a more meaningful interpretation of the composition by the performer of the acoustic part.

### **Background to the choice of notational symbols**

When designing the graphics for the electronic part, it is necessary to ensure that the images chosen are appropriate for the task. For Stroppa (Stroppa, 1984) a score is essentially a reduction of information which involves a knowledge of the materials involved, and a knowledge of the laws of the organisation of those material. The score must also be notated in a way that is easily comprehensible. A composer then need only notate only those elements of the composition which must be presented in detail. Other elements can be presented in less detail, as their meaning is assumed, or left to the interpretation of the performer.

If a performer is provided with a readily accessible visual representation of how an electroacoustic event will sound, then the performer will better understand how their acoustic instrument relates to the digital instrument and by extension fits into the overall context of the composition (Patton, 2007). A well-designed descriptive notation system which integrates with traditional notation should therefore result in improved opportunities for a more meaningful interpretation of the composition by the performer of the acoustic part.

Dimpker identifies the following criteria for non-standard notation (Dimpker, 2013):

- The criterion of exactness
- The criterion of simplicity
- The criterion of close relation to traditional notation

The first criterion aims at creating correct depictions of musical facts. The sense in which the depiction is “correct”, of course, is open to some debate. It is not necessary for the depictions to represent accurately all facets of a sound, in the manner of a sonogram for example, but rather depictions should give a sense of the most important aspects of a sound and should be consistently interpreted by performers in the same way. Dimpker gives as an example the depiction of a note to be produced by an acoustic instrument in standard notation.

The second criterion ensures that the music is represented in the simplest possible way. This is to ensure that musicians unfamiliar with the system can comprehend the notation quickly and produce accurate performances. The criterion also ensures that the notation functions as an intuitive tool for analysis.

Dimpker's final criterion, that of close relation to traditional notation, is also designed to ensure that the new methods of notation are easy to understand. Musicians are familiar with the conventions of traditional notation and so any notation system should build on these conventions if it is to be readily understood and accepted by its users. Furthermore, the new system of notation needs to integrate into a score which already contains traditional notation, thus it should, as far as possible, adopt the conventions of the traditional notation. For Dimpker, the two most important conventions which need to be adapted are, duration related to the horizontal axis and instantaneous comprehension.

The graphics used for the electronic part have thus been designed to be representative, exact in the sense that they give an indication of the most important aspects of the sound, simple to understand, and easily incorporated into a score which also contains standard notation. The graphics are also designed to be also be transferable to other compositions. The aim has been to identify "primitives" (Vaggione, 2001) derived from common practices in granular synthesis and the other post granular processes and represent them in a way that is intuitive to understand, precise and integrated with the traditional notation.

#### **Chapter 4: Composition for Piano and Electronics: *Thin Red Vein*. The Use of Microsound to Explore and Manipulate Gestural Surrogacy and Gesture/Texture Relationships**

This section explores issues relating to gesture and texture in mixed compositions. The issues are discussed in relation to the portfolio composition for piano and electronics: *Thin Red Vein*. A principal aim of the composition is to explore how gestures in the instrumental part can be transformed using microsound in order to create connections with the electroacoustic part. The section begins with a discussion on the nature of gesture before considering ways in which gestures in the instrumental part can be manipulated through microsound, in order to establish perceived causal relationships with the electroacoustic part. Surrogacy, source bonding, and gestural/textural relationships are explored as devices which can be used to create transformations and perceptual ambiguities. Ways in which microsound can be used as an organising principle to create aural and mimetic relationships, which in turn lead to an interplay between a perceived reality and a perceived abstraction, are also considered.

The portfolio composition *Thin Red Vein* uses as its main organising strategy the juxtaposition of sounds of a known, real world origin, i.e. the piano, with microsound transformations of gestures from the piano. The microsound gestures have no possible physical existence outside of an acousmatic context. One of the goals of the composition is to establish connections between the acoustic and the electroacoustic. It is important that throughout the composition a connection between the two sound worlds can be perceived. Sometimes the relationship between gestures is causal – the piano gesture may be perceived to have caused the electroacoustic gesture – and sometimes the connection is a framing relationship – the piano gesture exists in an acousmatic space created with material that similarly appears to have originated in some way from the piano. The gestures used by the piano can themselves be classified into a number

of different categories. The next section begins with a brief discussion on the nature of gesture in music before considering ways in which listeners may form connections between sounds. The section ends with a discussion on how these relationships may be manipulated using microsound illustrated with examples drawn directly from the composition.

### **Definitions of gesture**

The concept of gesture in music needs some clarification as it can be used to refer to a number of related ideas. In its broadest sense, musical gesture can be understood as “...a movement or change in state that becomes marked as significant by an agent” (Gritten & King, 2006). This definition, however, must be further refined in order to clarify which aspect of gesture is being considered. Lewis and Pestova identify some of these different aspects as: gesture as a bearer of meaning, gesture as a means of expression, gesture as the physical actions of a performer, or gesture as a structural or functional musical unit (Lewis & Pestova, 2012). They use the term *sounding gesture* to refer to gesture as a manifestation within the sound of those physical actions a performer undertakes in order to produce and control the sound.

An important point to note is that the agency causing the modifications in the sound need not be real but is rather perceived to be real by the listener. A sounding gesture in this sense becomes “...the sonic manifestation of any human physical action (real or imagined) that is directly responsible for (or is imagined to be responsible for) what we hear” (Lewis & Pestova, 2012, p. 2). When it is understood in this way, the notion of a sounding gesture can function as a means of uniting the instrumental sound world with the electroacoustic sound world. Causal relationships can be established through gesture, and microsound can be used to suggest a transfer of acoustic energy from the instrumental to the electroacoustic. Ways in which this may be achieved are now considered.

### **Using microsound to suggest a transfer of acoustic energy from the acoustic to the electroacoustic**

One very fruitful compositional strategy when writing instrumental music in an electroacoustic context is to create a continuum between a perceived reality and an abstract, or impossible, sound world. The application of microsound through granular synthesis can be used to transform instrumental gestures in such a way that they retain some of their spectral characteristics while simultaneously shifting other aspects of the sound. In this way connections between apparently disparate gestures can be created in the mind of the listener. In order to understand how these connections are formed it is first necessary to consider ways in which relationships between sounds are perceived.

Human beings are highly motivated towards correlating a sound with a sounding object or an action (Young, 1996). This aspect of human perception can be manipulated in order to allow sounds, which may not have any physical connections in reality, to co-exist in a sonic landscape. Smalley developed the concept of spectromorphology in order to describe and analyse the listening experience (Smalley, 1997). It is useful here to consider Smalley's analysis of the structural relationships between sounds to see how they may be manipulated using microsound. Smalley distinguishes between intrinsic and extrinsic threads, with intrinsic features being relationships between sound events as they exist within a piece of music. However, it is often the extrinsic features of a composition, those features which relate to the wider cultural context of the composition, that give meaning to the intrinsic features. In this sense the extrinsic and the intrinsic features of a composition are interdependent. Electroacoustic sounds, because of their often abstract nature, encourage listeners to construct extrinsic connections. Smalley uses the term *source bonding* to refer to these extrinsic connections which listeners make between sounds and their real or imagined causes. He defines source bonding as: "...the *natural* tendency to relate sounds to supposed sources and causes, and to relate sounds to each other because they appear to have shared or associated origins." (Smalley, 1997, p. 110)

These relationships exist with increasing levels of remoteness from any actual real world sounding body. Smalley introduces the concept of surrogacy in order to describe the ways in which sound objects become progressively removed from any sound making gesture which may correspond to an action takes place in reality. In first order surrogacy source/cause relationships are detectable in terms of direct effects of human gesture (Young, 1996). At this level of surrogacy sounds exist in a natural state before any instrumentation, transformation or other abstractions are applied for use in composition. Typically sounds with first order surrogacy are not used in instrumental music but they frequently appear in an acousmatic context. It is important, however, that the source and the type of gestural cause are recognisable otherwise the sound ceases to be first order. Second order surrogacy incorporates sounds with recognisable instrumental gestures. In the portfolio composition *Thin Red Vein* the unprocessed acoustic piano sounds can thus be regarded as second order. In third order surrogacy, gesture is inferred or imagined. The source or the cause of the sound may have been disguised or is ambiguous in some way. In third order surrogacy it becomes difficult to identify a sound with a known object or action. Smalley uses the term remote surrogacy for situations where the source and the cause of a sound are unknown and unknowable. At this level of surrogacy a listener may use non-sounding extrinsic links to make connections and infer meanings in the sound. These relationships may be entirely subjective and it is this perceptual ability to create imagined connections that makes bonding play such a powerful compositional device.

### **Adapting a taxonomy of gestural archetypes**

One of the central issues which arises when discussing the acoustic and the electroacoustic elements in mixed compositions is the lack of a common lexicon which could be used to describe events across both areas. As a step towards addressing this problem, Lewis and Pestova suggest a taxonomy of gestures for mixed instrumental music based on the three main phases of the sound: initiation, continuation and termination (Lewis & Pestova, 2012). Their classifications are not a cataloguing of the literal actions performed by the pianist in order to make the sound, rather they are an account of that which is

heard in the sound and the implied actions needed to create the sound. Lewis and Pestova's taxonomy will be adopted in the following sections because it offers a useful range of terminologies when discussing gesture in mixed compositions.

The first section of the piano part begins with a percussive gesture with a long sustain and decay phase. This is accompanied by a microsound transformation of the same gesture played back at 1/20<sup>th</sup> of the original speed. The effect is to transform the original percussive gesture of the piano part into a framing texture which shares the same spectral content and which appears to emerge from the original phrase. It is unclear to the listener whether the electroacoustic element is in some sense caused by the piano gesture or whether the two sounds are in fact one single gesture. The acoustic instrument then responds to the initial material with new percussive gestures in a lower register developed from the same harmonic material. After approximately 16 seconds the texture in the electronic part ends abruptly. The effect of this ending is heightened by manipulating the playback speed so that the sound file is reversed. This coincides with the ending of the first statement of the acoustic instrument. The process continues, with some minor variation, throughout the rest of the first section of the composition which ends at bar 20. Each time the acoustic instrument begins with a percussive gesture. This is framed with a transformed version of the same material. The piano then responds with further harmonically related gestures in different registers before the textural material ends abruptly.

The image shows a musical score for Piano and Electronics. The Piano part (top) is in 4/4 time with a tempo of 54. It begins with a 5-measure phrase marked *pp*. The Electronics part (bottom) also starts at 0'' with a 5-measure phrase marked *mp*. A 'time stretch' section follows, marked 'time stretch' and '(pbs 0.05) (pbs -1)'. The score includes a 'Cue 1' box and a 'Ped. sempre' instruction.

**Figure 51: Opening phrase of *Thin Red Vein* showing the initial percussive gesture, the framing texture and the response**

The effect is to establish an electroacoustic image where the microsound transformations of the piano gestures become background textures – relatively immobile grounds which create spaces for the piano gestures to inhabit. Because the only significant processing is the time-stretching, it is very easy for the listener to establish relationships between the electroacoustic and the acoustic. The timbral qualities of the sounds are essentially the same, it is the amplitude morphologies which have changed.

### Using Boulezian signals as musical discourse markers

The composition consists of six relatively autonomous sections. Each of these sections, with the exception of the last two, is separated by a short interlude on the piano unaccompanied by electronics. The piano interludes function as acoustic signs, or, to use the language of Boulez, “signals” which offer breaks from the musical discourse and mark important points in the structure of the composition (Goldman, 2011, p. 65). An example of Boulez’ use of signals can be found in *Anthème* (1991) for solo violin. In this piece Boulez punctuates breaks between sections with long notes which are intended to signal the end of

sections and to remove from the listeners' awareness any feeling of pulse from the previous section. The use of signals in *Thin Red Vein* follows Boulez's model quite closely. The lack of electronics is a deliberate strategy intended to weaken the memory of any electroacoustic treatments from the previous section. Again, as in Boulez's work, a signal is intended to be independent of the surrounding sections and to function as "...a brief but effective alert, a tear in the continuity, a rupture in the temporal flow" (Boulez quoted in Goldman, 2011, p. 65). A frequent characteristic of Boulez' use of signals is a sudden change in texture achieved through a marked drop in rhythmic speed or dynamic intensity or some other device. A similar effect is achieved in *Thin Red Vein* through the absence of microsound transformations. This sudden, marked change in texture serves to focus the listener and to signal a new event.

#### **Applying gestural archetypes to create relationships between different elements**

The section beginning at bar 26 introduces further electronic processing into the acousmatic elements. Time stretching is reduced to 1/10<sup>th</sup> of the original speed, spectral delay is added and elements of the sound file are reordered. The effect of this is to weaken the similarities between the acoustic instrument and its electroacoustic transformation and thus, by extension, weaken the bonding between the two sounds. Following the nomenclature introduced by Lewis and Pestova (Lewis & Pestova, 2012), the gesture used in the first section of the piece could be described as a push type percussive gesture while the dominant gesture used in the second section could be classified as a strike type.

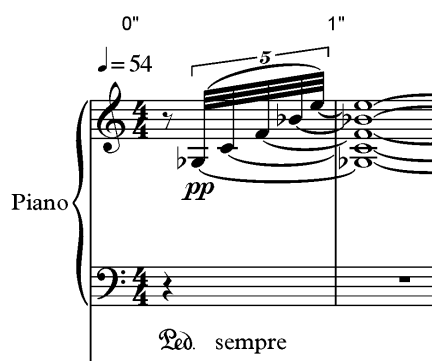

Figure 52: "Push" type percussive gesture

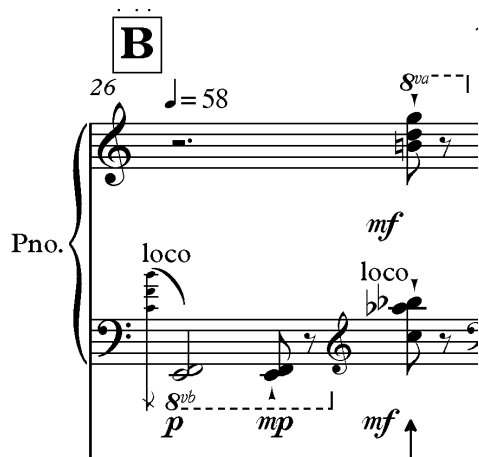

Figure 53: "Strike" type percussive gestures

The section beginning at bar 38 extends the push gestures in the acoustic instrument so that they function as gestures of onset and continuation. The theme of weakening the bonding between the acoustic and the acousmatic sounds is also continued. The electroacoustic sounds become more gestural and the interaction with the piano begins to shift from a framing relationship to a dialogue in which the acousmatic sounds respond to the piano. Figure 54 shows the extended push gesture together with its electroacoustic transformation.

Figure 54: Extended "push" gesture in the acoustic part and its transformation into an ambiguous gestural/textural relationship in the electroacoustic part

Although the electroacoustic sounds begin to function in a more gestural fashion and less as framing textures, they still retain some of the qualities of framing. Grain density is gradually decreased in order to reinforce the gestural nature of

the electroacoustic sounds. At the same time, spectral delay is introduced and the outputs of the three channels of the granulator are pitch shifted. The effect of this is to alter the amplitude profile and spectral content of the source material to a point where it is no longer easily identifiable from the piano. However, enough of the original spectral content and amplitude profile remain in the output for there to be an apparent connection established in the mind of the listener. These tensions between the textural and gestural nature of the electroacoustic sounds, together with the ambiguous relationship between the acoustic and the electroacoustic parts, realised through interpolating grain sizes, grain densities and pitch, result in a unified sound where the acousmatic seems to emerge naturally from the acoustic. These ideas are developed further throughout the rest of this section.

At bar 52 another gestural archetype is introduced into the acoustic part. Extended push gestures are now mixed with more iterative gestures where individual notes are repeated or rapid alternations are made between clusters of notes. The effect of this is a sense of attack and continuation rather than attack and decay. At the same time the electroacoustic part returns to a denser more textural state realised through decreasing the grain size and increasing the grain density. Playback speed is reduced to 0.05 of the original speed. Also, increasing use is made of the spectral delay, the delay modulation effects and pitch shifting to weaken significantly the bonding between the piano and the electronics. There is still, however, a connection between the two sounds as the way in which the electroacoustic follows the piano gestures suggests a causal relationship. There are also strong harmonic relationships between the two sounds. Examples of iterative gestures, together with a return to a more textural state in the electroacoustic part are shown in Figure 55.

Figure 55 shows a musical score for piano (Pno.) and electroacoustic (Elc.) parts. The piano part starts at measure 52 with a tempo of 56. It features iterative gestures framed by a denser texture in the electroacoustic part. The electroacoustic part includes parameters such as 'Cue 12', 'pbs 0.05, -0.05', 'partials', 'density 60, 60', and 'grain size 60, 60'. The piano part has dynamic markings *p*, *mf*, and *p*. The electroacoustic part has a tempo of 56 and a dynamic marking of *mf*.

Figure 55: Iterative gestures in the piano part framed by a denser texture in the electroacoustic part

The iterative gestures are developed further in the section beginning at bar 72. At the same time the grain sizes of extremely short duration and very slow playback speeds are introduced into the electroacoustic part. This can be seen in Figure 56

Figure 56 shows a musical score for piano (Pno.) and electroacoustic (Elc.) parts. The piano part starts at measure 72 with a tempo of 56. It features iterative gestures framed by textures created using very slow playback speeds and very short grain durations in the electroacoustic part. The electroacoustic part includes parameters such as 'Cue 17', 'grain size 8, 9, 5', and 'pbs 0.05, 0.01, 0.02'. The piano part has dynamic markings *ppp*, *mp*, and *ppp*. The electroacoustic part has a tempo of 56 and a dynamic marking of *mf*.

Figure 56: Further iterative gestures in the piano part framed by textures created using very slow playback speeds and very short grain durations in the electroacoustic part

This is again combined with pitch shifting and increased use of the delay modulation effect to create dense, resonating and slowly evolving textures to frame the piano. At bar 79 the texture is briefly interrupted by a rapid descending pattern of four notes ending in an abrupt decay. Simultaneously the

acousmatic texture fades out very quickly and causal relationship is suggested in the mind of the listener. This is shown in Figure 57.

The figure shows a musical score for Piano (Pno.) and Electroacoustic (Elc.) parts. The Piano part is in treble clef with a key signature of one flat. It starts at measure 79 with a dynamic of *mf*, then changes to *ppp* at measure 80, and returns to *mp* at measure 81. The Electroacoustic part is in treble clef and includes cues for Cue 18 and Cue 19. Cue 19 is marked with "(time stretch sim. sempre)". The Electroacoustic part also includes a "partials" section with parameters: fq 1.85, 1.8, 1.2; win 20, 10, 15; phase 2, 4, 8; fb 0.1, 0.2, 0.3. The dynamic for the Electroacoustic part is *mf*.

Figure 57: An abrupt fade in the electroacoustic part coinciding with a sudden rapid descending gesture in the piano part to suggest a causal relationship

The gesture/texture relationship returns in bar 81 and continues to the end of the section.

The section beginning at bar 89 continues directly from the previous section without an unaccompanied piano interlude that has separated all the previous sections. This is a compositional strategy intended reinforce a sense that the piece is moving towards a conclusion. For the final section many of the gestural archetypes introduced in previous sections return while at the same time the electroacoustic part once again becomes more gestural in nature. This is achieved by interpolating the playback speed and the grain duration. Use of pitch shifting is also extended to add to the gestural qualities of the electroacoustic part. Juxtaposing very long grain durations with very short grain durations also adds to the sense of ambiguity in the textural/gestural nature of the electroacoustic part. Again, the use of abrupt, strike gestures, push gestures and iterative gestures in the acoustic part, juxtaposed with occasional rapid fades in the electroacoustic part adds to a sense of dialogue and of causal relationships between the acoustic and the acousmatic. Examples of these techniques can be seen in Figure 58.

The image shows a musical score for Piano (Pno.) and Electroacoustic (Elc.) parts. The Pno. part is in treble and bass clefs, starting at measure 98. It features dynamic markings *pp* and *ppp*, and includes a section marked "loco". Time signatures 7'14", 7'18", 7'22", and 7'26" are indicated above the staff. The Elc. part is in treble clef and includes a "Cue 23" box. It features parameters for "grain size" (20, 800, 30), "pitch" (800, -200, 600), and "pbs" (0.1, 0.01, -0.15). There are also "time stretch" and "mf" markings. Pedal markings "Ped." and "Ped. (sempre)" are present between the staves.

Figure 58: A variety of gestural archetypes in the acoustic part juxtaposed with interpolating grain sizes, pitch and playback speeds in the electroacoustic part to suggest dialogue and causal relationships

*Thin Red Vein* demonstrates ways in which a variety of gestural archetypes produced by an acoustic instrument can be transformed through microsound techniques in order to establish causal relationships, framing relationships and to play with notions of source bonding in a mixed compositional environment.

**The harmonic language used in the acoustic part of *Thin Red Vein***

The starting point for the acoustic part of the composition was the harmonic progression shown in Figure 59. The piano part was then freely composed using this progression as a pool of material. The progression was used as a compositional resource rather than a template to be strictly followed.

The image shows a chord progression on a grand staff (treble and bass clefs). The progression consists of several chords, including triads and dyads, with various accidentals (sharps, flats, naturals) and stems. The chords are arranged in a sequence across two staves.

Figure 59: Chord progression used as a compositional resource for *Thin Red Vein*

## **Chapter 5: Composition for Piano, Bass Clarinet and Electronics: *With Time Not In Time*. Issues of Control and Interface Design and the Roles of the Performer, the Composer and the Listener**

In this section issues relating to the role of the performer and the relationship between the performer and the composer will be discussed. These issues will be discussed with reference to the portfolio composition for piano, bass clarinet and electronics: *With Time Not In Time*. Reference will also be made to the composition for saxophone and live electronics: *Five pieces for saxophone and electronics*. In order to explore the issues fully it will first be necessary to consider the differences between digital instruments and acoustic instruments and how the design of acoustic instruments influences their use in an acousmatic context. This will lead into a discussion on the design and control of digital performance environments and how these are influenced by issues of affordance and constraint. Next, human control of the digital environment will be compared with machine control and the relative merits of each will be considered. Although the ideas raised are relevant to many different musical contexts, they are discussed here with particular reference to digital environments created for this portfolio and which are designed to carry out microsound transformations of acoustic instruments.

### **Using acoustic instruments in an acousmatic context**

It has already been noted that one of the problems faced when combining acoustic instruments with digital instruments is that traditional acoustic instruments have in general been developed to serve an aesthetic very different from the aesthetics of acousmatic music and non-instrumental live electronic music<sup>1</sup>. Acoustic instruments have generally been designed to produce a distinctive, stable, recognisable and relatively narrow range of timbres. They also tend to have pitch and intonation mechanisms that favour equal temperament.

---

<sup>1</sup> The term “non-instrumental” here is used in a very narrow sense to refer to music made without traditional acoustic instruments: clearly there are a whole range of digital instruments and hybrid instruments which do not fall into this category.

Most traditional acoustic instruments such as those of the modern orchestra have been developed to serve the aesthetics of the nineteenth and early twentieth centuries. Composers and performers wishing to use traditional instruments as vehicles for exploring new textures and timbres have had to develop new techniques that were often never intended by the original instrument designers and are not needed for the traditional repertoire. That is to say, the rise in interest in exploring extended instrumental techniques, beginning in the twentieth century, has been driven by composers and performers seeking to extend the range of timbres available to them beyond that for which the instruments were originally designed.

Electronic and acousmatic music has been driven, at least in part, by a search for new sounds and new relationships between sounds. This approach has had a strong influence on instrumental composition and performance practice. The rejection of existing models combined with the opportunities presented by emerging technologies has led musicians to develop new ways of approaching timbre and by extension new approaches to instrumental composition. The most flexible environment in which to develop and explore textures and timbres would seem to be a well equipped, computer centred, modern recording studio. Techniques such as the digital processing of concrete or environmental sounds, or the production of sounds wholly synthesised in a digital environment seem to offer the composer a limitless palette from which to work. Furthermore, modern technology has for some time now allowed many digital processing techniques to be carried out in real time. The live performance of electronic music using a variety of techniques, interfaces, digital instruments etc. is very much coming of age as an art form. Despite this, traditional acoustic instruments remain both popular and relevant among composers, listeners and performers. The question then is what qualities and affordances do traditional instruments offer to the listening community which sees them continuing to thrive, in specific communities at least, despite the vastly extended musical palette offered by electronics? Another way of wording this would be to ask why modern composers still choose to work with traditional instruments when the opportunities offered by electronics are so seductive?

When contrasted with fixed media and live electronic music, and even considering the possibilities offered through extended techniques, the relatively limited range of possible timbres that can be produced by traditional acoustic instruments might seem to make their use redundant. In this context a pessimistic appraisal would be that traditional acoustic instruments are at best reduced to being just one more source of concrete sounds for the composer to manipulate, either in a studio environment or in real time.

Furthermore, it could even be argued that acoustic instruments have some inherent disadvantages for composers and performers seeking to work with new sounds in new contexts. Traditional instrumental sounds tend to be readily identifiable when compared to the sounds produced by electronics. They also often carry with them various associations, expectations, traditions and repertoire that can at best be interpreted as a distraction and are not always appropriate in a modern context. It will be argued here, however, that it is exactly this cultural inheritance, as well as the readily identifiable nature of the sounds they produce, that make them so attractive to performers, composers and listeners. The ways in which familiar sounds can be presented in unfamiliar contexts, as demonstrated in the portfolio composition *Thin Red Line* and *The Sea Turns Sand to Stone* among others, or the ways in which causal and mimetic relationships can be manipulated and explored, and just some of the reasons that acoustic instruments continue to be of relevance to many composers working in modern, acousmatic contexts.

Despite their continued relevance, it should be noted, however, that since the mid part of the 20<sup>th</sup> century there has been a significant cultural shift in that traditional acoustic instruments are no longer the dominant source of the sonic material available to composers that they once were. The result of this is that the skill sets needed by composers and musicians are radically different to what they were before the middle of the 20th century. Indeed, since the 1980s and the rise of personal computers and the MIDI protocol this changing skill set has accelerated dramatically. The flexibility offered by modern digital instruments,

processing software and digital audio workstations, together with an increased blurring of boundaries between various genres of popular and academic music, mean that traditional acoustic instruments have shifted from being the primary source of sound production in the music of first half of the twentieth century to being simply another available tool in an increasingly powerful and diverse arsenal at the beginning of the twenty-first century. The result of this is that for many composers it is no longer necessary to have what might have been considered traditional music skills in order to make music. Shifting aesthetics and modern technology mean that skills such as an ability to play an acoustic instrument, an ability to read and write traditional Western notation, an understanding of harmony and orchestration etc. are no longer prerequisites for anyone wishing to make music and indeed are irrelevant in many contexts.

These are some of the reasons why many modern composers and performers have abandoned traditional instruments entirely; indeed, they may never have had a relationship with those instruments in the first place. The compositions in the portfolio, however, are one example of a body of work which demonstrates that acoustic instruments can still be relevant a modern context.

It is clear, therefore, that despite all the increasing alternatives, new music<sup>2</sup> which incorporates traditional acoustic instruments, either on their own or mixed with electronics, remains a viable medium for exploration. Why certain composers and performers in the modern age continue to see a value in working with traditional instruments is worth considering in more detail. This in turn will help to define more clearly the role of the acoustic instruments in this portfolio.

Simon Emmerson has talked about the need to humanise technology and to resist the tendencies of technology to dehumanize people (Centatus Music Projects, 2010). He goes further by suggesting that there may even be an ethical dimension to this in that human beings ought to bring their human qualities into performances and ought not to allow themselves to become subservient to the technology. These, admittedly loosely defined, human characteristics are just

---

<sup>2</sup> Another problematic term! There has always been a strong tradition of orchestral, chamber and solo music where the need for acoustic instruments by definition can remain unquestioned. I am referring here to music influenced by acousmatic traditions where the need for acoustic instruments is much less obvious. Between these two points there exists a continuum of approaches.

some of the many qualities that performers of acoustic instruments can bring to the music. This human agency can also be extended to the control of the electronic part in a live performance. Putting a human being at the centre of a musical performance introduces an agency capable of making decisions and reacting to the present moment in a way that no pitch tracking device or score following algorithm has yet achieved. A human performer can respond intuitively to another performer (human or machine, live or fixed media) in ways that greatly increase opportunities for interactivity and engagement. Furthermore, it has already been demonstrated that if the human is playing a traditional acoustic instrument, then the traditions, cultural assumptions and expectations that instrument carries can be manipulated, implicitly or explicitly, to enhance the performance.

If we accept that placing human agency at the centre of a performance is a positive model we can now explore more deeply other positive aspects that acoustic instruments can bring to a performance. What features do performances and compositions incorporating acoustic instruments have that are lacking in the other models?

One important reason for choosing to use acoustic instruments with electronics is that a competent human performer is able to produce a range of gestures, dynamics, rhythms etc. that are at best challenging and at worst impossible to replicate digitally in real time. A skilled performer is able to draw upon a tradition of performance practice and playing techniques that can be either incorporated directly into a composition or mapped into a digital environment. Another reason for including acoustic instruments is the range of sounds offered by those instruments. We have already commented on the fact that the range of timbres offered by acoustic instruments is relatively limited when compared to the open ended possibilities of the acousmatic sound world, and that they carry with them traditions and associations which can be unhelpful. However, acoustic instruments have an inherent musicality and harmonic richness that a good performer is able to manipulate skilfully and intuitively. The familiarity of the sound world offered by acoustic instruments, the very aspect which could be

considered a disadvantage in the context of strict acousmatic composition, can be used by composers and performers to blur boundaries between physically possible sounds and sounds which could only be created in a digital environment, or to create transformations between the familiar and the unfamiliar. A dialogue can be developed between the acoustic and the electronic with the relationships between the two being explored in a number of ways. The electronics could be used to enhance the sound world of the acoustic instrument, or to contrast with it. The acoustic instrument can act as a point of familiarity. The electronics can be used to challenge that familiarity. This relationship, and the way it can be manipulated through the use of microsound, is central to many of the compositions in this portfolio.

Having considered the role of acoustic instruments, as well as the relationship between those instruments and electronics, it is now necessary to consider issues raised when designing models for controlling the electronic part and to show how these ideas have been applied during the realisation of the portfolio of compositions.

All of the compositions included in this portfolio are, to some extent, interactive. They are interactive in the sense that there is always some form of dynamic, real-time relationship between the performers of the acoustic instruments and the electronic part. Often, from a performance perspective, this relationship is interactive only in the loosest sense in that a performer of the electronic part will trigger pre-composed cues, which are then executed by the computer in real time, at specified points in the score. The electronic rendering is therefore live and differs from a fixed media rendition of the part in that there are always enough random variables in the electronic processing to make the part different every time it is processed, even if the differences are often extremely subtle. To the listener, however, it often feels as though the music is much more interactive than it actually is.

There are many examples in the portfolio where the listener could perceive causal relationships between the acoustic performance and the resulting

electronic output, even where such causal relationships may not actually exist. That is to say, the music has often been composed to sound as though the performer of the acoustic part is triggering an electronic event whereas in reality the electronic event is triggered by a single cue which in turn triggers multiple automated events and gives an impression of more interactivity than is actually present. In two of the compositions, however, namely *With Time Not In Time* and *Five Pieces for Saxophone and Electronics*, the performances are designed to be genuinely interactive in the sense that it is the performer of the acoustic part who is also controlling the electronic part in real time. The instrumental part then changes in response to the electronic part, creating a feedback system between the two. In both instances a pitch-tracking algorithm has been incorporated into the software and trigger notes have been written into the score. Also in both cases the performers are invited to improvise with the software in order to manipulate the processing of their own instruments in real time. The amount of freedom afforded to the performers, as well as the extent to which the performances could be considered successful, will be considered in a later section. Firstly, however, it is necessary to consider the issues raised when designing performance environments with which musicians are able to improvise in real time. We begin by considering how to decide which features, or affordances, of a digital audio environment should be made available to a performer or a composer. We also consider how limitations, or constraints, can, perhaps counter-intuitively, actually increase creativity.

### **Affordance and constraint**

Developing ideas from Gestalt theory, the psychologist James Gibson first put forward the concept of affordance in the late 1970s (Gibson, 1979). The term refers to qualities or properties inherent in objects or environments which allow, or suggest, actions. Gibson originally used the term to refer to all possible actions, whether or not they were perceived by an agent. The use of the term was later restricted by Donald Norman to refer only to those possibilities for action which are readily perceived by the agent (Norman, 1988). Thus the affordances of an object or an environment are dependent upon the intentions, abilities and

cultural background of the agent. The object “suggests” uses to the agent and those uses which are suggested depend on the circumstances which the agent brings to the situation. Affordances can also be hidden or false. A false affordance is one which suggests a certain outcome but which does not produce that outcome, for example a misleadingly labelled parameter on an interface. A hidden affordance is a possibility for action which exists but which is not visible to the agent, a particular combination of keystrokes or controllers which has not been documented, for example. Developers and manufacturers tend to build affordances into the design of their products in order to guide consumers towards easily discoverable possibilities. It is also a widespread practice to use packaging to reveal affordances to the end user. Apple computers, for example, often package their products in such a way that their uses are gradually revealed to the consumer during the unpacking process. The commercial motivations behind these practices are clear: customer satisfaction and lifelong brand loyalty.

Constraints can be thought of as the opposite of affordances and describe the limitations of objects or environments. Constraints can be physical, logical or cultural (Norman, 1999). An example of physical constraints in music would be the physical limitations of conventional acoustic instruments, such as frequency and dynamic range, possible timbres etc. Although composers and performers experiment with extended techniques, ultimately the repertoire of sounds which a conventional instrument is able to produce is bounded within the physical possibilities of that instrument. These constraints, however, also have the effect of restricting a user to a particular environment and thus focusing creativity on the resources available within the parameters. This can often result in increased creativity.

Logical constraints are those where the user has a restricted number of options and must use reasoning to determine the possible outcomes. A website, for example may have a limited number of pages to view and the user must decide on the most appropriate link to click. In music, certain forms and genres have very clear logical constraints. It is often the ways in which a composer

manipulates these constraints that determines the success of a composition. This example clearly overlaps with the next category, cultural constraints.

Cultural constraints are conventions shared by a cultural group. Norman (Norman, 1999) gives the example of a graphical vertical scroll bar positioned on the right of a computer screen as a culturally learned convention. There is nothing inherent in the design that requires the system to act in this way: it is simply a culturally accepted convention.

When designing an interface, the technological relationship between the user and the instrument is determined by constraints and affordances and how they are implemented onto the conceptual model of the instrument. The mapping of affordances onto the engine of the instrument will influence not only the available repertoire of sounds which the instrument could produce, but also the usability of the instrument. Too many affordances will result in an instrument that is confusing to learn and cumbersome to play. The careful application of constraints to the conceptual model will effectively increase the potential for creativity in the instrument by making affordances more clear and increasing usability.

For the compositions *With Time Not In Time* and *Five Pieces For Saxophone and Electronics* a pitch-tracking algorithm was incorporated into the software and a performance environment was designed with the intention of encouraging the performers to improvise with the material. The improvisations were much more carefully controlled in *With Time Not In Time*, partly as a result of lessons learnt during the creation of *Five Pieces for Saxophone and Electronics*. The following sections describe the features included in the performance environment and reflect on the advantages and disadvantages of incorporating improvisation into compositions for acoustic instruments and microsound processing. We begin, however, by considering different models for controlling the electronics and discussing which is the most appropriate in this context.

## Models and precedents for controlling electronics when used with acoustic instruments in real-time performance

We now consider the various performance models and relationships that influenced the decisions taken when designing the control systems for electronics used with acoustic instruments in real time performance for this portfolio. Although these models are applicable to a wide range of composition and performance situations, it is important here to consider how they can be applied specifically to the exploration of microsound. The models and their relationships are summarised in Figure 60.

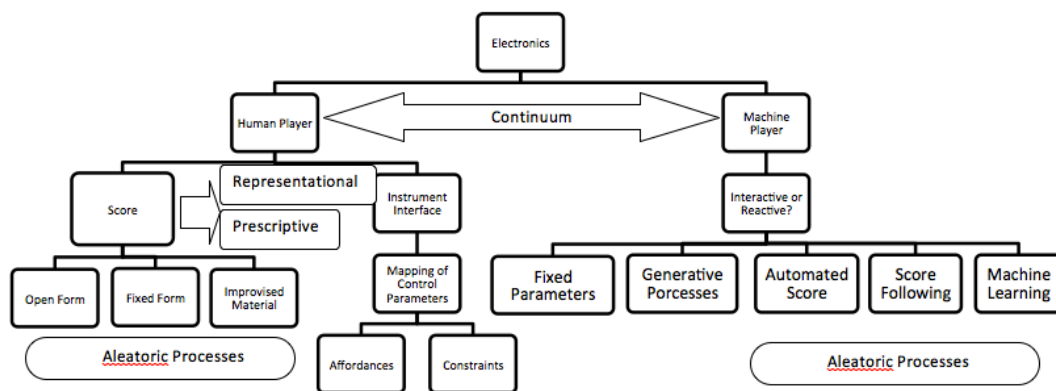

Figure 60: Models and relationships for the control of electronics

It is important to remember that human computer relationships exists on a continuum; there are a range of models for control available, with automated computer systems on one end and systems controlled by human performers on the other. The first decision is whether the electronics should be controlled by a human performer, by the computer or by some combination lying on the continuum between the two. We begin by considering issues raised if the electronics are to be controlled by a human performer.

### Human control of electronics

A human performer will need a means of interfacing with the sound engine and this raises issues of parameter mapping, affordances, constraints etc. These have

been discussed more fully in an earlier section. The performer of the electronics may or may not play from a score. Compositional decisions will determine if there is a need for a score and the nature of the score that may be used. Broadly speaking, and again accepting that various combinations are possible, the material will be either improvised, carefully notated, or, as in the case of *With Time Not In Time*, it will be a combination of an improvised approach and notation. An advantage of this latter approach is that it allows parameters to be clearly defined within which the improvisation can develop. For *Five Pieces for Saxophone and Electronics* the performer was encouraged to improvise freely with the material using the performance interface, and indeed was very willing to do so. However, although the results were aesthetically and artistically satisfying, there were no clear boundaries set for the improvisation and the performance depended too much on the improvisational abilities of the particular performer. The result of this was that the composition was not repeatable in any sense where different performances could still be considered to be of the same piece. (This raises interesting questions as to when a performance of a composition ceases to be “the same” but it is outside the scope of this commentary to discuss those issues here). Also, when the composition was tried with other performers, the lack of guidelines for the improvisations meant that the results were often inconsistent and unsatisfactory, especially if the performers were not already experienced improvisers, and it is mainly for these reasons that the composition has been omitted from the main portfolio. I now offer some different models for notating the electronic part.

The score could be in a fixed or an open form (Stockhausen's *Klavierstücke XI* (1956) is one example of an open form composition, there are many other models). The score may also contain any number of other aleatoric processes. Questions then arise concerning the nature of the notation that is to be used and how the score is to be presented. Should the score be representative of the sounds produced or should it be purely prescriptive? If representational material is included or excluded in the score, will this influence the performance? These and other issues relating to the design of a score for a human performer have been explored in an earlier section. However, it is important to note here that

they will influence the design of the electronic interface and the choice of features available to the performer.

### **Machine control of electronics**

If the computer is to be used as the principal agent for controlling the electronics, then models of control afforded to the machine become the issue. Is the computer system passive, reactive, or interactive? Can a computer system, incapable of making aesthetic judgements but arguably capable of mimicking aesthetic judgements, ever be considered truly interactive? Or are there just degrees of reactivity? If a passive model is chosen, which we could refer to as the “effects processor” model, then the source material will be processed by the computer but there will be no updating of the parameters as the performance unfolds. Such a system could, of course, still include parameters which change state over time; a low frequency oscillator, for example. Such a system may appear at first to be somewhat limited but of course the output of the system will reflect the input. If the input is coming from an acoustic instrument, then all the expressiveness and spectral content of the acoustic performance could still be present in the output. There could also be generative processes built into the software to control the electronics in the composition. These could be triggered at the beginning or at any stage during the performance and allowed to develop over the course of the piece. For these models to work parameters will need to be defined and set, and generative processes will need to be designed and initiated. There is, however, no need for a score in any traditional sense. As soon as models are introduced which do rely on scores then issues such as repeatability and interactivity arise. These are discussed in the next section.

### **The automated score: recording controller data for playback during performance**

If we define the score as some sequence of instructions defining the instrument’s state at different points during the composition then a very simple model for scoring the electronic part for machine performance would be to record controller data during the composition process and to use this as an automated score to be played back during performance. One implication of this approach is

that some form of human computer interface would need to exist and this again raises the issues of interface design referred to in the previous section. Recording and playing back controller data has an obvious limitation in that unless the source material used during the performance is identical to the source material used during the composition process then the automated controller movements will no longer be relevant. The only way to ensure that the material is identical would be to use a pre-recorded sound file. Furthermore the movement of the controller data would need to be perfectly synchronised to the playback of the source material. Any performers of acoustic instruments would also have to synchronise exactly to the electronic part. This is all clearly impractical if live acoustic instruments are to be used as the source material. Possible ways to overcome the limitations of such a model would be to use a machine listening and learning system or to use a score following system such as IRCAM's Antescofo (Cont, 2008).

Some of the early prototypes of the compositions in this portfolio incorporated an automatable interface capable of recording and playing back controller data in real time. This model was quickly abandoned, however, because of the problems discussed in the previous paragraph. The interface can be seen in Figure 61.

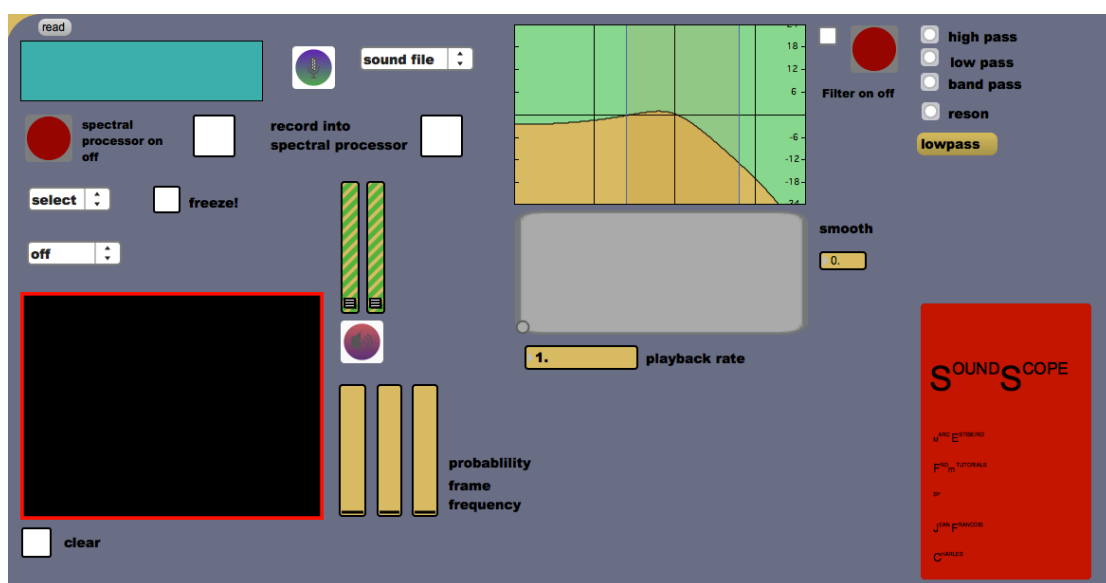
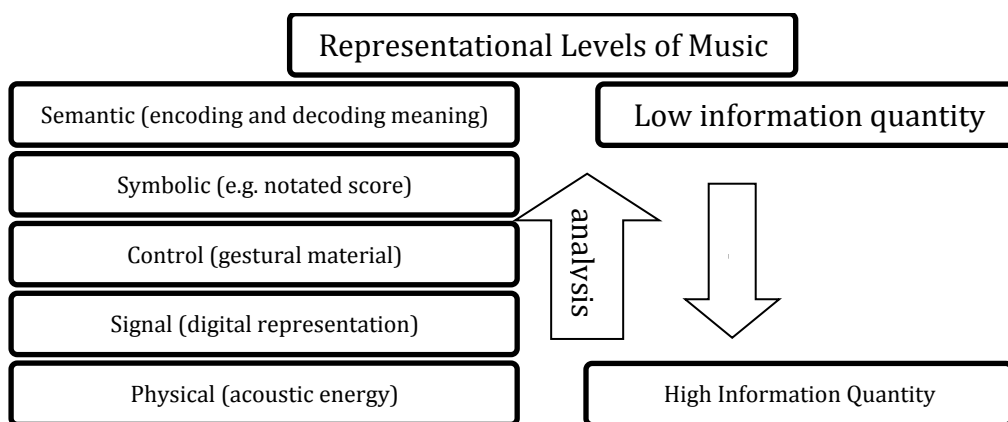

Figure 61: An early version of the interface used for the compositions in the portfolio. This interface was capable of recording and playing back controller data

## Machine listening

In machine listening and learning models, the computer is “trained” to recognise certain features of the input material, for example pitch, timbre, amplitude etc., and these are then used as triggers to implement different sets of parameters or generative processes in the software during the performance. This model eliminates or reduces the need for human agency during the performance stage. A machine listening learning device has to recognise music on a number of levels and the way in which the computer responds when the material has been recognised will determine how interactive or reactive a system will be. Music exists on different representational levels (Cont, 2010), some of which are easier to encode into a computer than others. These are summarised in **Figure 62**.

At the top is the semantic level. This is the hardest level for a computer to encode or decode as it consists of embedded meaning which a human listener is able to interpret only through a complicated network of implicit knowledge on social, cultural, and psychoacoustic levels. An example of music on the



**Figure 62: Representational levels of music. Adapted from** (Cont, 2010)

symbolic level would be a notated score in which the semantic level of music is encoded into representational symbols to be interpreted by a performer. Musical gesture (in the sense of performance gesture) exists on the control level. Music at the signal level is perhaps the easiest to represent as this refers to acoustic energy which is converted into voltage with a transducer, sampled using an analogue to digital convertor, and then stored and manipulated. Music on the physical level refers to the physical excitation of a body to produce acoustic

energy. All of these different levels of representation will have different data rates on a computer and all will arrive for analysis asynchronously requiring complex sets of relationships in order to analyse the music. There is also a directional hierarchy to the levels. In order to synthesise a musical sound the direction is from the top to the bottom (semantic to physical) while to analyse a musical sound the direction is from bottom to top (physical to semantic). A machine listening learning system which aims to be at least partly interactive would need to be able to discriminate between these levels to at least some degree.

Figure 63 shows some of the features which a machine listening learning system could track.

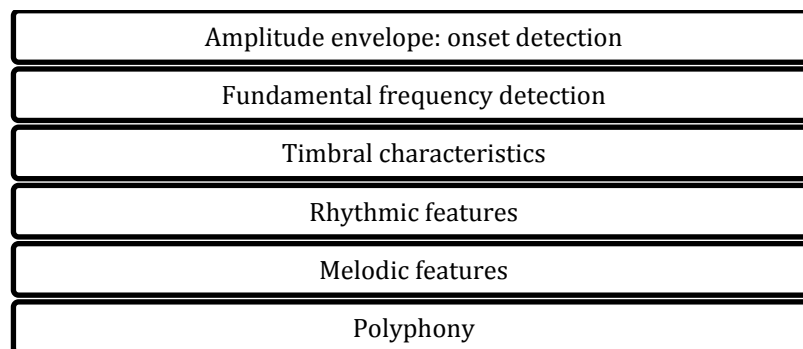

Figure 63: Examples possible data for machine recognition

An example of a machine listening system is the analyzer~ object developed by the Center for New Musical Research at Berkeley (CNMAT, 2012). Analyzer~ is an FFT based Max MSP external which can output values for pitch (as a raw frequency in Hertz and as a MIDI note value), loudness, brightness, noisiness, and Bark scale values. The user can set values to limit amplitude thresholds, pitch deviations (vibrato), re-attack times and harmonic partial weighting. The user can also define window size, hop size and windowing function. It is stable and easy to implement although it is more effective when used to track fundamental frequencies and amplitude variations rather than timbral information. It is the analyzer~ object that has been used as the pitch tracking algorithm for the compositions in the portfolio.

ll~ is a machine listening learning device (also available as a Max MSP external) developed by Nick Collins (Collins, 2011) and used in the composition *schismatics II* by Sam Hayden (Hayden & Kanno, 2011). ll~ was initially developed as a tool for machine human improvisation and is able to analyse an input stream in order to index different timbral and rhythmic clusters. In *schismatics II* Hayden preloads the ll~ object with preset data files so that it will recognise different timbral clusters produced by an e-violin during the performance. These are then used to trigger different scenes in the electronics which correspond to different movements of the composition. Hayden reports that the object made the computer's behaviour less predictable which lead to a greater sense of computer agency and hence increased interactivity between the computer and the performer.

Other important work on timbral recognition has been carried out by Bill Hsu (Hsu, 2010).

### **Score following**

Score following involves the real time synchronisation of an acoustic performance with the score of that performance. Antescofo (Cont, 2008) is one such system which analyses a real time audio stream and identifies the score position and tempo from the performance. This information can then be used to synchronise computer generated performance parameters with the acoustic performances (IRCAM, 2007-2012). Aligning a real time performance with a symbolic score involves embedding a representation of the score within the program. Antescofo uses its own score format but can also import scores formatted in MIDI or Music XML, both of which are available as export options in most popular music processing packages. Antescofo can follow polyphonic audio streams as well as fundamental pitch (in Hertz). It can also be adapted to accept a MIDI performance as an input. Antescofo can also communicate directly in real time with the score editor Note Ability Pro (Hamel, 2000-2007).

There are some potentially serious limitations when dealing with score followers. Real time score following systems can encounter problems when dealing with performance errors (the signal input deviating from the embedded notation: i.e. missing notes, extra notes or wrong notes). There can also be serious problems if synchronisation is lost during a performance. Antescofo would appear to be a very stable and reliable system with regard to these issues and thus it would be an appropriate environment to use in a project such as this. A recommendation for future work would be to incorporate such a system into the compositions.

### Designing an interactive interface

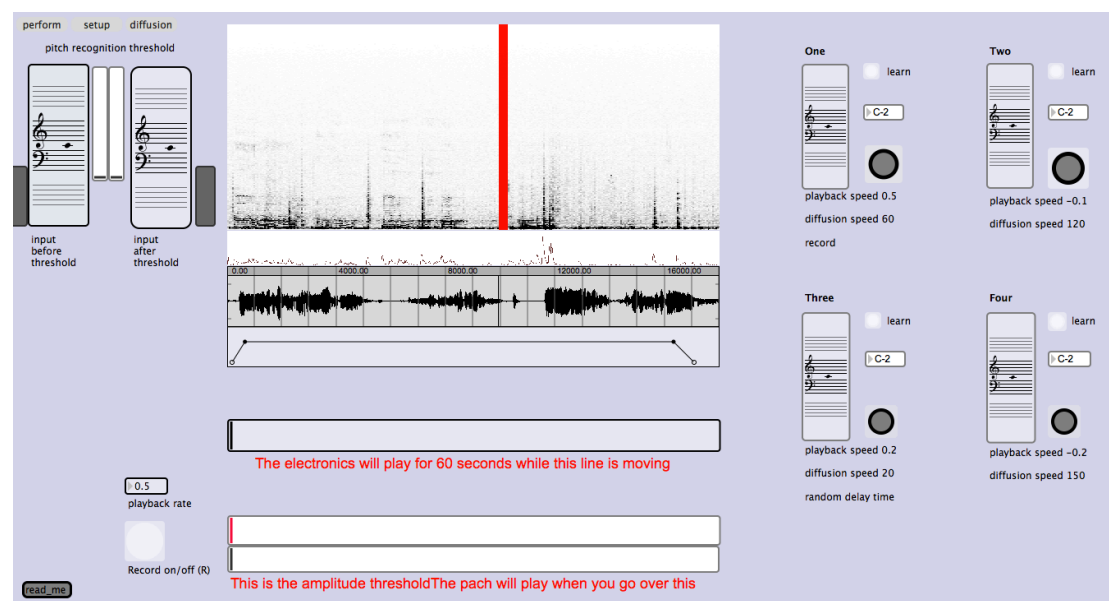

**Figure 64:** The interface for the interactive Max patch used by the performers for *With Time Not In Time* and *Five Pieces for Saxophone and Electronics*

Figure 64 shows the interactive interface used for the compositions *With Time Not In Time* and *Five Pieces for Saxophone and Electronics*. The interface was mapped to an FFT based spectral processing patch. The version of the software shown also included an automated four-channel diffusion system and a delay line with a randomised delay time, although neither of these features were used on the version of *With Time Not In Time* included in the portfolio.

After some experimentation informed by discussions with performers, and after considering their feedback carefully, the following features were incorporated onto the interface. First of all, the interface was designed to be easy to see in a

performance context, taking into consideration the fact that the performer would also be reading from a score. Necessary instructions were kept to a minimum and presented in a bright colour to draw the user's attention to them. A very prominent red scroll bar was also included in order to make it easy for the musician to see whereabouts in the audio buffer the computer was reading. More detailed information and instructions were included in a "read me" patch positioned in the bottom corner of the screen. The environment was controlled with four programmable trigger notes, which would initiate events when the amplitude of the input signal exceeded a user determined setting. It was not possible for the end use to re-map the trigger notes to different parameters. It was relatively easy task, however, for the composer to reprogram the patch in order to remap the trigger notes to different parameters. The number of trigger notes used was kept deliberately low. The performer was thus able to control the following parameters:

- Trigger note 1: playback speed (0.5), diffusion speed (60), start recording
- Trigger note 2: playback speed (-0.1), diffusion speed (120)
- Trigger note 3: playback speed (0.2), diffusion speed (20)
- Trigger note 4: Playback speed (-0.2) diffusion speed (150)

The environment was designed so that after the amplitude threshold was exceeded, the audio buffer would play for 60 seconds during which time the performer would be able to change the speed and direction of playback, randomise the delay time, or initiate a new recording.

### **Defining the boundaries for improvisation in the score**

The most successful early implementation of the patch was on the composition *Five Pieces for Saxophone and Electronics*. However, the score for that piece contained little information as to the nature of the improvisation, which was instead mostly left to the discretion of the performer. Although the performer featured on the recording found this empowering and fully engaged with the software, other performers who experimented with the environment found the

experience to be intimidating and failed to engage with the environment in any meaningful way. For this reason, as well as other reasons discussed in an earlier section, the improvisatory elements were much more carefully controlled for *With Time Not In Time*. An example from the score is shown in Figure 65.

6

Repeat the material freely until the electronic part has finished playing

*Sempre senza misura*

Move freely between air note and half embouchure

pp mp pp mp

Move freely between air note and half embouchure

pp mp

Play this when the electronic part has ended

Listen for this phrase then move to the next section

play the E<sub>2</sub> normally while finding the harmonic inside the piano with the other hand. Try to find the 7th harmonic but the exact pitch of the harmonic is not important

Rapid gliss. over strings with fingertips

pp

Make rapid movements along the strings near the E<sub>2</sub> with the brass guitar slide

mp

Make rapid movements along the strings near the E<sub>2</sub> with the brass guitar slide

pp mp pp mp

mp

*Sempre senza misura*

60"

Playback speed = 0.1

Figure 65: Improvisation section from *With Time Not In Time*

A graphic at the bottom of the page shows a representation of the audio buffer. Also shown is an indication of the length of time for which the buffer will be playing. The performers are presented with a series of gestures in boxes that they are to be played independent and not necessarily in order. Verbal instructions are also included which tell the performers to repeat the material freely until the electronic part has finished playing. The marking “*sempre senza misura*” is also included to encourage the musicians to play in free time. As only the bass clarinet player is able to view the computer screen, and is therefore the only performer who will be able to see when the electronic part will have finished, an aural cue is included which acts as an instruction to the piano player to move to the next section.

The uses of the trigger notes and amplitude thresholds are also very carefully controlled in the composition. They are notated into the score and presented

with verbal instructions in order to make their function clear. An example of this is shown in Figure 66.

The image shows a musical score excerpt with three staves. The top staff contains a sequence of notes with dynamic markings *pp*, *mf*, *pp*, and *fff*. A box above the notes contains the text: "This is a trigger note - crescendo until the playback direction changes then play the slap tongue to trigger playback". An arrow points from this box to a specific note. A label "Slap tongue" is placed above the staff. The middle staff shows a 5:4 ratio indicated above a group of notes, with dynamics *pp* and *f*. The bottom staff shows a tremolo effect labeled "tr" and a fermata over a note. A "Ped." marking is at the bottom.

Figure 66: Excerpt from *With Time Not In Time* showing the use of trigger notes and amplitude thresholds

There are, of course many precedents for the controlled approach to improvisation described above. Lutosławski, for example, in his composition *Jeux Vénétiens* (1961) makes use of controlled aleatoric techniques where chance processes are allowed to develop within tightly controlled formal and harmonic boundaries.

### The harmonic language used in *With Time Not In Time*

The harmonic language of *With Time Not In Time* was initially derived from the sets of pitches shown in Figure 67 and Figure 68 below.

The image shows a single musical staff in treble clef with a key signature of one flat. It contains a sequence of seven notes: G4, F4, E4, D4, C4, B3, and A3.

Figure 67: First pitch set used in *With Time Not In Time*



Figure 68: Second pitch set used in *With Time Not In Time*

Various transformations were then carried out on the pitch sets to generate new reservoirs of material. For example, in Figure 69 below the final four notes of the first pitch set have been inverted chromatically around E<sup>b</sup>.



Figure 69: Transformation from first pitch set

The reservoir of material was then used to construct a series of monophonic gestures and chords. An example of a gesture constructed from the first two modes is shown in Figure 70.



Figure 70: Gesture constructed from first and second pitch sets

Examples of the chords used are shown in Figure 71. Much of the chordal language in the composition is composed from re-voicings and variations on this material.



Figure 71: Examples of chords constructed from pitch sets

Finally, multiphonics are used in the bass clarinet part to find chordal material which was felt to complement the extended techniques and the harmonic language of the composition. Examples of the multiphonics used are shown in Figure 72 below.

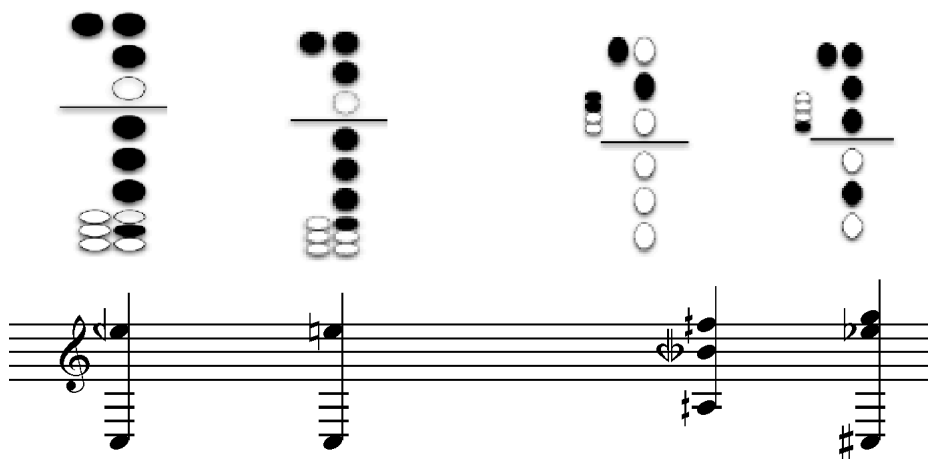

Figure 72: Examples of bass clarinet multiphonics used in *With Time Not In Time*

### Issues arising from the use of an interactive environment

Although it was felt that the composition *With Time Not In Time* was successful, various issues that arose during the composition and rehearsal process, some pragmatic some aesthetic, meant that the idea of using an interactive environment to control the microsound processing, and thus delegating responsibility for the control of the electronic part to the performers of the acoustic instruments, was ultimately abandoned. Other compositions in the portfolio use an additional performer to control the electronic part. Furthermore, none of the other compositions feature improvisation to any significant extent and the cues for the electronic part, even when allowing for variations introduced by randomised parameters, are very rigidly controlled and often pre composed. Some of the reasons why the interactive interface and the improvisational elements were not included in other pieces are discussed in the next section.

One of the main reasons that the model was not extended was because of the restrictions it placed on the compositional process. Because of the way the electronics are controlled, the trigger notes have to be embedded in the score. Certain notes need to be reserved for controlling the electronic part. Also dynamics above a certain threshold must be used with caution as these could trigger events unintentionally. This puts unavoidable restrictions on the material available for the composition.

There are also pragmatic reasons why the model was abandoned. Sufficient time needs to be allocated in the rehearsal period for the careful setting of thresholds and to “teach” the computer programme the trigger notes. It is often the case that in real world situations there is very limited time available for the musicians to rehearse the piece and to discuss the control of the electronic processes with the composer. In reality there is usually not nearly enough time to set up the electronics correctly. Furthermore, assuming responsibility for the control of the electronic part can be an inhibiting experience for a performer. It is reasonable to conclude that in a practical situation, with minimal rehearsal time and with performers who may be unused to working with electronics, allowing the performers too much freedom, both with regard to controlling the electronic part and improvising with the electronic part, is an inherently problematic strategy. Again, defining the parameters for the control of the electronic part and the improvisations, or perhaps even removing these responsibilities from the performers completely, would address these issues. Pragmatic issues such as these are very important, as usually composers do not have the luxury of working with musicians who have the time available for extended rehearsals.

**Chapter 6: Composition for Piano, Flute, Bass Clarinet and Electronics:  
*Interventions*. Composition for Contrabass Flute, ‘Cello and Electronics:  
*Earth White Fracture*. Conflicts Between Note based and Texture Based  
Approaches to Composition. Using Microsound to Manipulate a Range of  
Materials across a Structural Framework**

This section considers issues relating to perceived conflicts that may exist between note-based and texture-based approaches to composition. These issues are considered in relation to the portfolio compositions *Interventions* for flute, bass clarinet, piano and electronics and *Earth White Fracture* for contrabass flute, ‘cello and electronics. The two compositions adopt very different approaches to the challenges of combining a note-based approach to composition with a texture-based approach. Although *Interventions* is an interesting work and a satisfying aesthetic experience, the approaches adopted in *Earth White Fracture* are generally felt to be more successful. The reasons for this are explored here. The section begins by considering the differences between note-based and texture based approaches to composition.

**Note-based and texture-based approaches to composition**

A note based approach to composition could be considered to be one in which the musical note is the primary unit of organisation in the process and where compositional strategies can ultimately be reduced to the manipulation of musical material on the level of the note. A note here is defined as a sound with a recognisable pitch which can be mapped to a symbolic representation using standard notation and which typically also includes information relating to duration, dynamic and articulation. Typical examples of note-based approaches to composition would include interval-based approaches, the permutation of series, the manipulation of tonal progressions etc. A note is, in a sense, transferable between instruments in a way that a texture is not.

A texture-based approach to composition by contrast could be considered to be one in which the manipulation of the spectromorphological relationships which

exist in the sound material inform the compositional strategies. Composition incorporating concrete sounds, micropolyphony, spectralist approaches, and stochastic music could in this sense be considered as examples of texture-based approaches. It is very important to note, however, that harmony and texture are essentially interrelated manifestations of the same phenomena. There is not always a clear distinction between the two. Rather, it is the ways in which the musical material is generated (e.g. equal tempered notes from acoustic instruments or field recordings of concrete sounds), manipulated (e.g. notes arranged in standard notation on a score or soundfiles processed in a computer) and perceived (e.g. tonal relationships or spectromorphological relationships) which inform the difference.

The section continues with an overview of the composition for flute, bass clarinet and piano: *Interventions*.

#### **Features of the composition: *Interventions***

*Interventions* differs from other compositions in the portfolio in that while the acoustic part is carefully structured and notated, the electroacoustic elements are intended to be realised, at least to an extent, in real-time during the performance. The performer of the electroacoustic part makes live recordings during the performance and then triggers different cues, which are indicated in the score. The performance environment is used to improvise with the material. There are similarities with the compositions *With Time Not In Time* and *Five Pieces for Saxophone and Electronics* in that aleatoric elements and improvisation play an important part in the work. Unlike those pieces, however, these elements are restricted to the performer of the electronic part. Many of the discussions in Chapter 5 concerning interface design, control of the electronic part and establishing boundaries for improvisation, are applicable to this composition. However, as the focus of this section is the relationship between the note based material and the texture based material, these issues will not be discussed extensively here. A brief overview of the control of the electronic part is given below.

## The electronic performance environment and score

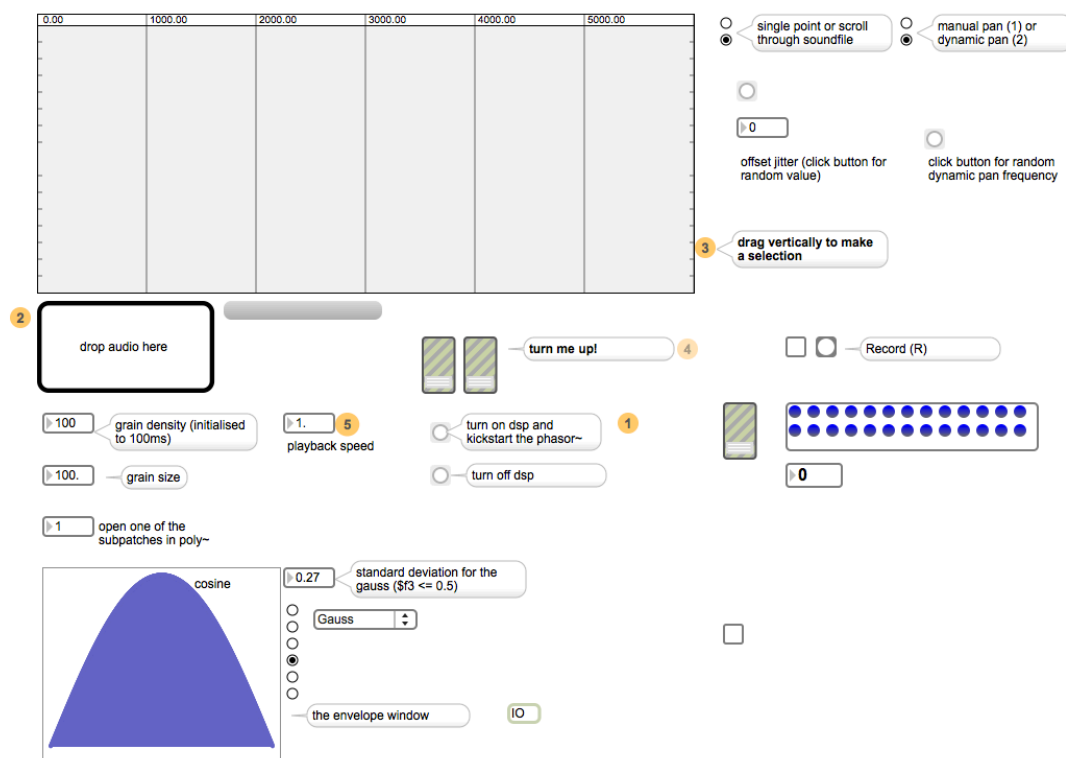

Figure 73: Performance environment used for *Interventions*

Figure 73 shows the performance environment used in the composition. The environment is an early version of the more sophisticated environments used for compositions which were written later in the development of the portfolio, namely *Thin Red Vein*, *The Sea Turns Sand to Stone*, *Displaced Light* and *Earth White Fracture*. The most significant differences are that in this version of the environment, there is only one channel for granulation and there are no post-granulation effects. Also, there are several affordances available to the composer or performer that did not contribute in any real sense to either the compositional process or to the performance. For this reason these features were removed from later versions of the environment. In particular the ability to select different grain envelopes and the spatialisation features were removed. It is not that these features were considered unimportant; rather they did not contribute significantly to the compositional aims of the works in this portfolio.

The environment includes a feature for storing and recalling presets. These are incorporated into the score in the form cue numbers. There is also a record

feature. This is also incorporated into the score. An example showing the features used for the electronics is shown in Figure 74.



Figure 74: Excerpt from score for *Interventions* showing cue numbers, record and notation for electronics

Crescendo and diminuendo markings are given in standard notation to indicate the points in the score when the electronic part is to be played. Graphical notation, in the form of a waveform symbol, is also used to show the electronic part. One major criticism of the score for *Interventions*, however, is that the graphical notation does not carry any information on the nature of the sounds playing. It is useful only as an indication as to where the electroacoustic part should be sounding. It is the inherent limitation of this notation that led to the development of the more sophisticated notations used in other compositions in this portfolio.

### Limitations of live recordings

In *Interventions*, the electronic part uses material from the acoustic instruments recorded in real time during the performance. The material then reappears, transformed by the performance environment, in a different context. In this respect the composition is similar to *With Time not In Time*, which is discussed more fully in Chapter 5. There are points in the score for *Interventions* where the electroacoustic material is heard unaccompanied by the acoustic instruments and other times where it enters into a dialogue with the acoustic instruments. An important finding for this project was that it became apparent that the use of recordings taken during the performance, as opposed to using pre-recorded sound files of the instruments, results in a lack of compositional control, which ultimately was felt to be aesthetically unsatisfactory in this context. Furthermore, as the process of taking real-time recordings during the performance was generally felt to be invisible to the listener it is not an important factor in the reception of the piece. The use of pre-recorded sound files allows for much

greater compositional accuracy while still maintaining the integrity of a live aesthetic which would be lost if the electroacoustic part was pre-recorded entirely. Because sounds are still being processed in real-time, with subtle but significant differences in parameter settings introduced both by the patch itself and by the human controller of the patch, each performance is a unique event. It is for these reasons that other compositions in the portfolio, including *Earth White Fracture*, use pre-recorded sound files. That is not to say that the use of live recordings is never appropriate.

### The use of note based material in acoustic part of Interventions

The instrumental part of the composition was initially structured around the following number series: 6, 4, 5, 3, 1, 2. This series was used in the first instance as the basis for the harmonic structure of the composition although, as the work developed, the number series became less detectable. However, the series is still clearly perceivable in the rhythmic structure of the piece, particularly in the piano part. Figure 75 shows the beginning of the piano part where the use of the number series can be seen in both the left and the right hand. The series appears in many other parts of the score but it is important to note that it functions as a compositional tool intended to generate interesting material and it is not a system designed to be followed rigorously and which dictates the structure of the work. The piano part continues to bar 42 after which the material is inverted chromatically and retrograded to create second half of the composition.

The image displays a musical score for the piano part of the piece 'Interventions'. It consists of two systems of music, each with a treble and bass clef staff. The first system shows a sequence of notes in the right hand with dynamics *p*, *mf*, and *pp*. The left hand has notes with dynamics *mf* and *f*. Above the first system, a double-headed arrow labeled '6' spans the first six measures, and another labeled '4' spans the next four measures. Below the first system, arrows labeled '1', '3', '2', and '5' indicate rhythmic groupings. The second system continues the piece with dynamics *p*, *mp*, *f*, and *pp*. Above the second system, arrows labeled '5', '3', '1', '2', and '6' indicate rhythmic groupings. Below the second system, arrows labeled '4', '6', and '2' indicate rhythmic groupings. The score includes various musical notations such as slurs, accents, and dynamic markings.

Figure 75: The beginning of the piano part of *Interventions* showing the number series used in the left hand and the right hand

The flute and the bass clarinet engage in a dialogue with the piano and with each other.

The harmonic material for *Interventions* is derived from the chord shown in Figure 76.



Figure 76: Original chord from *Interventions*

The notes in the chord have been reordered to produce the pitches shown in Figure 77

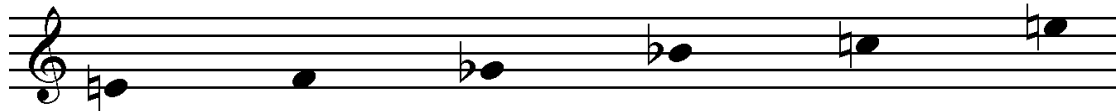

Figure 77: Pitches derived from original chord for *Interventions*

These pitches are then combined with their retrograde inversion, transposed down one semitone to give the symmetrical set shown in Figure 78. The use of mirror symmetry around a central axis can also be found in Harvey's *Madonna of Winter and Spring* (Harvey, 1986).

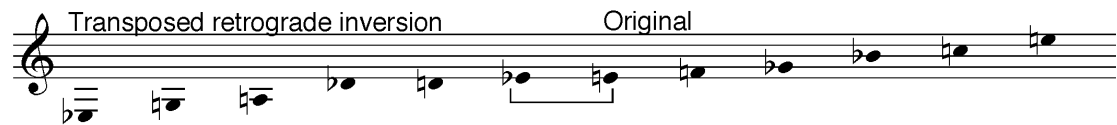

Figure 78: Symmetrical pitch set for *Interventions*

This set of pitches is then used to generate the chords shown in Figure 79 which are generally, although not exclusively, constructed from every fourth degree of the scale.



Figure 79: Original harmonic series for *Interventions*

Each chord is then paired with its chromatic inversion re-voiced in a higher octave. This is shown in Figure 80



Figure 80: Chords paired with chromatic inversions

The lowest notes of the chords are taken to produce the sequence shown in Figure 81 (immediate repetitions of notes are ignored).



Figure 81: Bass sequence derived from lowest note of chord sequence for *Interventions*

The sequence shown in Figure 81 forms the basis of the left hand piano part in *Interventions*. The right hand part is constructed from the remaining chords. Approximately half way through the piece, the structure is reversed and repeated.

It is important to note that the system described above has been used only to generate a resource of harmonic and melodic material. The system has not necessarily been strictly followed and there are frequent variations and transgressions introduced for compositional interest. The structure is also deliberately interrupted at regular intervals by more gestural and less harmonic material (the “interventions” of the title). The flute and the bass clarinet continue this theme of responding to the piano part with gestural interventions into the overall structure.

### **An integrated, structural approach to the creation of a continuum between the acoustic and the electroacoustic**

In *Interventions* the electroacoustic and the acoustic inhabit quite different spaces with few intrinsic connections other than the fact that one is a direct transformation of the other. A contrasting approach was adopted for *Earth White*

*Fracture*, for contrabass flute, 'cello and electronics. Here, the relationship between the electroacoustic and the acoustic, as well as the role of microsound in mediating that relationship, was considered from the beginning of the compositional process. A structural framework, which shows the interrelationships between the different aspects of the composition, is shown in Figure 83. The 'cello moves through twelve different sections and through twelve different gestures, moving broadly from essentially static material towards more dynamic material at the centre of the structure. For the second half of the composition the material moves back toward the static. While the harmonic language for the 'cello part is determined by the nature of the extended techniques, the material for the contrabass flute is broadly taken from the octatonic scale shown in Figure 82. The scale is used to construct the gestures for the contrabass flute which move from a state of support to a state of conflict with the other elements in the composition, before returning to a state of support. The process can be seen in Figure 83.



**Figure 82: Octatonic scale used for the contrabass flute part in *Earth White Fracture***

The 'cello part makes extensive use of harmonics and extended techniques to create the source material for the electronics. The source material, however, exists as pre-recorded sound files rather than real time recordings taken during the performance. The listener perceives the sound moving between the acoustic and the acousmatic. The use of extended techniques blurs the boundaries between the two. The use of pre-recorded sound files affords a degree of compositional control which would not be possible with real time recordings. For the listener, however, the use of sound files rather than real time recordings should not be an issue in the reception of the work.

The parameters for the electroacoustic material move across a continuum of opposites, which are mapped onto the score and realised in different cues. The 'cello and its acousmatic transformations are perceived as a unified and evolving mixture of texture and gesture. The role of the contrabass flute is to engage in a dialogue with both the 'cello its microsound transformations, supporting and

complementing the material and the beginning and the end of the composition and conflicting and working against the material at the centre.

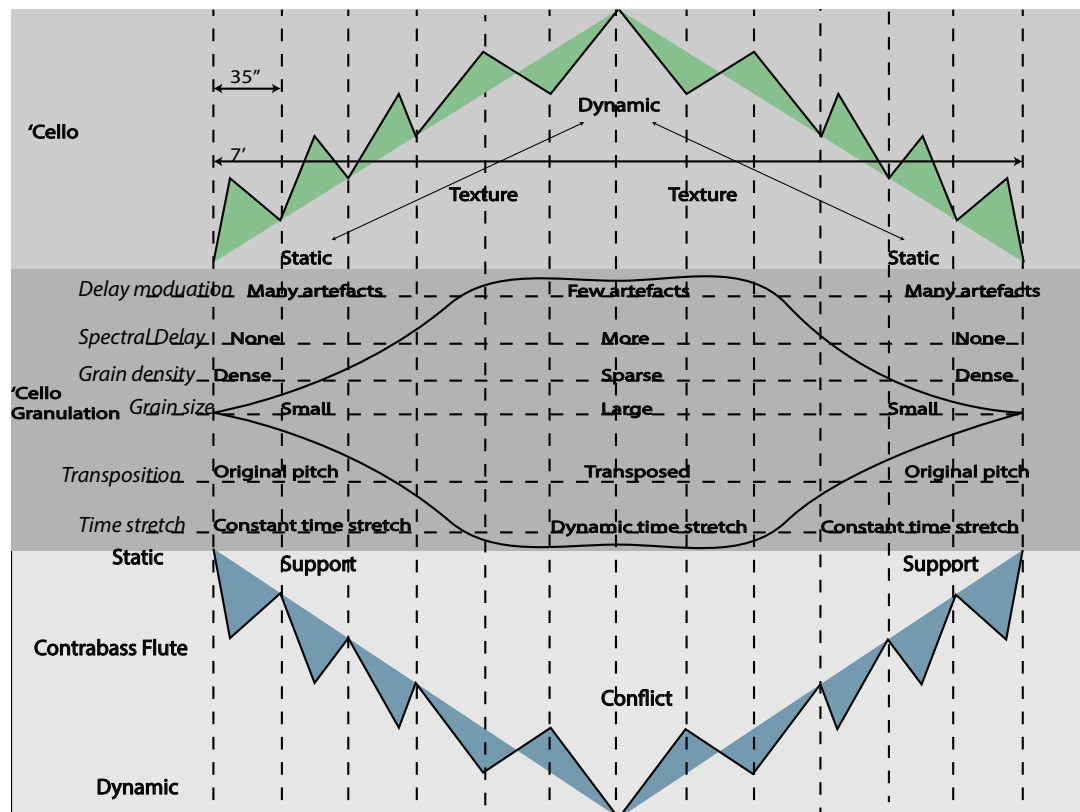

Figure 83: The structural framework used as a guide during the composition of *Earth White Fracture*

Carefully controlling both the macrostructure and the microstructure of the work, as well applying the use of extended techniques to shift the sound of the 'cello from the acoustic into the acousmatic, results in a much more coherent composition than *Interventions*. Although the underlying structures may not always be apparent to the listener, the result is nevertheless a more unified and satisfying experience where the acoustic and the acousmatic integrate more successfully.

## **Chapter 7: Composition for Six Instruments and Electronics: *Displaced Light***

### **Using Microsound Techniques to Create and Extend a Repertoire of Gestural Archetypes**

*Displaced Light*, for six instruments and live electronics, represents a synthesis of many of the different issues that have emerged during the development of this portfolio. It is an example of the use of microsound, realised through granulation, in a live context. The electroacoustic part and the acoustic part have been integrated from the beginning of the composition process through structural frameworks informed by the application of microsound. The electroacoustic part has been notated and related to the acoustic part through the application of a new system of graphical notation. The sound of the acoustic instruments is always to some degree perceivable, however remotely, in the electroacoustic material.

#### **Aims of the composition**

One of the principal aims of the composition is to create a work in which gestural archetypes are used to create an environment where texture and harmony are treated as separate but integrated structural elements. That is to say, the composition should treat texture and harmony as separate parameters but with frequent points of contact mediated through the application of a hierarchy of gestural archetypes in both the electroacoustic and the acoustic parts. cf (Saariaho, 1987, p. 124). Also, the electroacoustic elements of the composition should be integrated with the acoustic elements from the beginning of the compositional process. Microsound is therefore used in a number of ways. Namely:

- To complement the gestural archetypes used by the acoustic instruments by moving through a similar structural framework
- To expand the spectral content of the acoustic instruments
- As a technique for mediating the integration of harmony and texture
- To extend existing spectromorphological relationships and to contribute new spectromorphological relationships, including gesture/texture relationships, foreground/background relationships, and framing relationships

- To engage in a dialogue of tension and resolution both with the acoustic part and with elements in the electroacoustic part

As with the other compositions in the portfolio, the electroacoustic part is notated in a way that is meaningful in the sense that the notation functions both as a graphical representation of the sound and as a set of instructions which would allow the sounds to be recreated. The notation of the electroacoustic part is also designed to be intuitive to read.

Microsound has again been used in conjunction with instrumental techniques to create a coherent structure based on a pure-sound/noise axis in a way which is consistent with other compositions in this portfolio, namely *Earth White Fracture* and *The Sea Turns Sand To Stone*. However, in this composition the gestural archetypes do not unfold in a strictly linear hierarchy. That is to say, gestures reappear out of sequence both in their original forms and in hybridised variations in order to add tension and compositional interest to the work. The harmonic content used by the acoustic instruments is derived from repeated transformations of a single chord. This process is described in the next section.

### Harmonic structure

Central to the acoustic elements of the composition is the chord shown in Figure 84. This chord consists of a root note, a minor second above the root and an augmented triad a fifth above the root.



Figure 84: Root plus minor 2nd with augmented triad 5th above root

The chord is inverted chromatically around the root and then transposed up one octave as shown in Figure 85.



Figure 85: The same chord inverted around F4 and transposed up one octave

A second chord is then created from the first chord. The highest note of the chord remains the same while the second highest note is transposed downwards by one semitone, the third by two semitones, the fourth by three semitones and so on. The result of this is shown in Figure 86



Figure 86: Transposing each degree of the chord (except the top note) downwards by an increasing number of semitones to create a new chord

As the resulting chord contains an octave (e flat), this note is transposed up a semitone. The result is shown in Figure 87



Figure 87: the chord from fig 72, together with the original chord, adjusted to avoid octaves

The process is then repeated to produce a series of five chords. These five chords are then inverted and transposed in order to produce another series of five chords. The notes of the chords then become the pitches used by the acoustic instruments in each section of the composition. The series is shown in Figure 88

The figure displays five rows of musical notation, each representing a section of the composition. Each row consists of two staves (treble and bass clef). The sections are labeled as follows:

- Section A1** and **Section B1** (Row 1)
- Section C1** and **Section D1** (Row 2)
- Section E1** and **Section E2** (Row 3)
- Section D2** and **Section C2** (Row 4)
- Section B2** and **Section A2** (Row 5)

The notation shows various chords and melodic lines, with some sections having boxes around specific notes.

**Figure 88: Harmonic structure of the composition**

The pitches shown in Figure 88 form the basis of the harmonic structure of the composition. The central sections, labelled E1 and E2 in Figure 88, are combined, making nine sections in total. Each section is approximately one minute and thirty seconds long, although timings are not intended to be absolute and will vary in different performances. As in *The Sea Turns Sand To Stone* extended

instrumental techniques are used to create a continuum between pure sound and noise. Each section represents an arc beginning and ending with pure sound and moving towards noise at the centre. As the composition progresses, the continuum shifts progressively towards noise and away from pure sound until the centre point of the composition is reached and the process is reversed. The composition differs from *The Sea Turns Sand to Stone*, however, in that the gestural archetypes do not unfold in an entirely linear manner. Natural tensions between pure sound and noise, between texture and gesture, and between the acoustic and the acousmatic are deliberately exploited for compositional effect. Gestural archetypes appear out of sequence in both the electroacoustic and the acoustic parts in order to interrupt the linearity of the structure and create compositional interest. A broad schematic of the process is shown in Figure 89

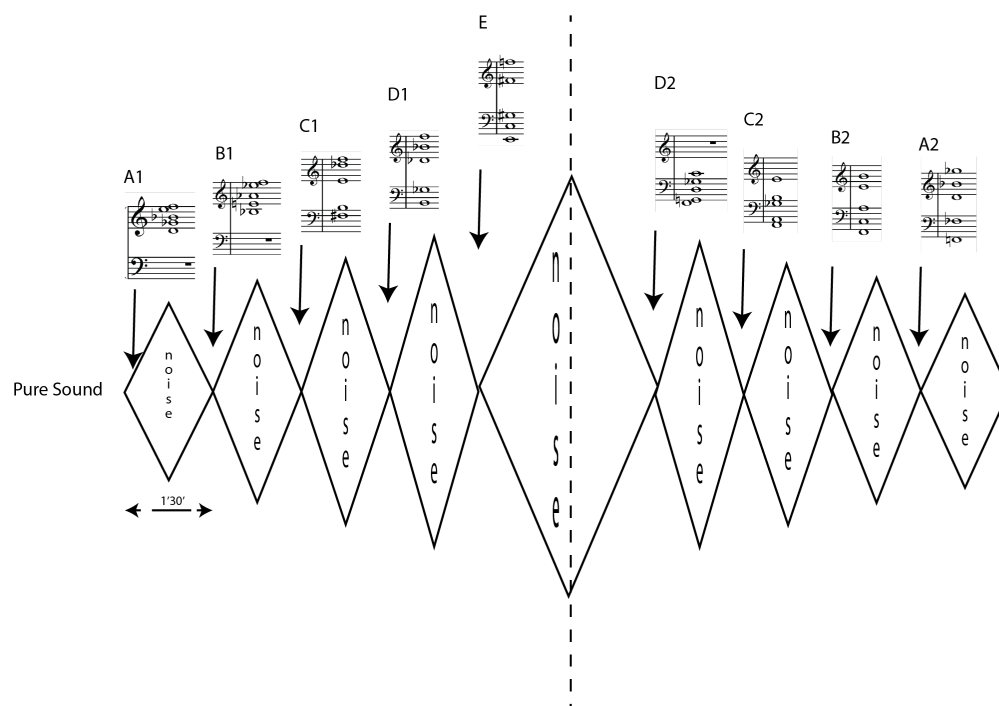

**Figure 89: Overall structure of the composition showing relationship between noise and pure sound and the harmonic basis**

### **Instrumentation and relationship to electronics**

The following acoustic instruments are used in the composition:

- Flute
- Bass clarinet

- Vibraphone
- Piano
- 'Cello
- Double Bass

As the composition progresses, each instrument moves through a series of gestural archetypes, progressing broadly along arcs from pure sound to noise and back. The linearity of the progression is, however, frequently interrupted by restatements of earlier archetypes and by hybridised variations on individual phrases. A broad overview of the archetypes used is shown in Table 6.

Figure 90 to Figure 94 show the moments at which the principal gestural archetypes appear in the first half of the composition. After Section E the structure is reversed and repeated with material moving from Section D to Section A.

**Table 6: Gestural archetypes used in the composition listed by instrument and in the order in which they appear**

<b>Flute</b>	Mid range Slow attack and continuation No vibrato	Mid range Slow attack and continuation Ordinary vibrato	Rapid burst and continuation	High register harmonic Slow attack and continuation	High register whistle tone with appoggiatura Rapid attack and continuation	Tongue ram Short attack and decay Strike gesture	Rapid burst and rapid decay Strike gesture	Tremolo with appoggiatura Iteration	Ord. to flutter- tongue Pure sound to noise Slow attack iteration/push	Air notes to ord. Noise to pure sound
<b>B. Clarinet</b>	Mid range Slow attack and continuation No vibrato	Rapid burst and decay	Rapid burst and continuation	Slow attack and continuation with trill	Rapid burst and tremolo Iteration	Tremolo and continuation Iteration	Slap tongue Short attack and decay Strike gesture	Ord. to flutter- tongue Pure sound to noise	Multiphonic Slow attack and continuation	
<b>Vibraphone</b>	Bowed harmonic Slow attack and continuation	Rapid burst and tremolo with continuation	Tremolo Slow attack and continuation	Rapid burst and decay	Rapid burst repeated pitch Iteration and rapid decay	Polyphonic tremolo Iteration and continuation	Tremolo to ord. slow attack and continuation	Bowed note with pedal Slow attack and continuation		
<b>Piano</b>	Sustained chord Slow attack and continuation	Rapid burst and continuation	Rapid burst Repeated pitch Progressively mute string	Silent chord with single glissando across strings	Harmonic	Scratch string while holding silent chord Low register	Hit strings with palm and let ring	Very rapid glissandi over strings high register		
<b>Cello</b>	Slow attack and continuation Norm to sul tasto. Gradually increase bow pressure	Ord. to harmonic	Tremolo stopped note and stopped harmonic with glissando	Rapid burst and decay with and without glissando	Rapid burst pizzicato	Ord. to tremolo	Natural harmonic with tremolo and trill to open string With glissando	High register rapis glissandi with tremolo	Col legno tratto Col legno battuto	Low register Very gradual gliss with tremolo
<b>D.Bass</b>	Natural harmonic Slow attack and continuation	Tremolo Slow attack and continuation	Stopped harmonic	Rapid burst and decay with and without glissando	Stopped harmonic glissandi and tremolo norm to molto s.p.	Ord. to harmonic to tremolo. Norm to molto s.p.	Col legno tratto Col legno battuto	Low register Very gradual gliss with tremolo		

Principal gestural archetypes used  
by the acoustic instruments

Section A

	0	10"	20"	30"	40"	ELECTRONICS	50"	1'00"	1'10"
Flute									
Bass Clarinet									
Vibraphone									
Piano									
Cello									
Double Bass									

NB Gestures are not proportional to timeline  
Shows approximate start only

Figure 90: Principal gestural archetypes used in section A

Principal gestural archetypes used  
by the acoustic instruments

Section B

	ELECTRONICS							
	1'20	1'30	1'40"	1'50	2'00"	2'10"	2'20"	2'30"
Flute								
Bass Clarinet								
Vibraphone								
Piano								
Cello								
Double Bass								

NB Gestures are not proportional to timeline

Figure 91: Principal gestural archetypes used in section B

Principal gestural archetypes used  
by the acoustic instruments

Section C

	ELECTRONICS								
	2'40	2'50	3'00"	3'10"	3'20"	3'30"	3'40"	3'50"	4'00"
Flute	whistle tone (sempre) <i>ppp</i> → <i>pp</i>			tongue ram <i>f</i> → <i>mp</i> → <i>mf</i>			ord. tongue ram <i>f</i>		
Bass Clarinet	<i>mf</i> → <i>p</i>			slap tongue <i>mf</i> → <i>p</i> → <i>mf</i>			ord. slap tongue (sempre) <i>mf</i>		
Vibraphone	<i>mf</i> → <i>p</i> → <i>mf</i>			<i>p</i> → <i>mp</i>			<i>p</i> → <i>mp</i>		
Piano	<i>mp</i> → <i>p</i>			<i>mf</i>			<i>p</i> → <i>mf</i>		
Cello	<i>mp</i>			<i>mf</i>			<i>pp</i> → <i>mf</i>		
Double Bass	<i>mp</i>			<i>pp</i> → <i>mp</i>			<i>mp</i> → <i>mf</i>		

NB Gestures are not proportional to timeline

Figure 92: Principal gestural archetypes used in section C

Principal gestural archetypes used  
by the acoustic instruments

Section D

ELECTRONICS

	4'10"	4'20"	4'30"	4'40"	4'50"	5'00"	5'10"	5'20"	5'30"	5'40"	
Flute	tongue ram <i>sfz</i> ord. <i>f</i> → <i>mp</i>			p → <i>f</i> → p → p → <i>mf</i>							
Bass Clarinet	slap tongue <i>sfz</i> ord. <i>p</i> → <i>f</i> → <i>mf</i>			p → <i>mf</i> → p							
Vibraphone	<i>sfz</i> <i>mf</i> → <i>f</i> → <i>mp</i>			<i>mp</i> < <i>mf</i> ppp ppp							
Piano	(ord.) <i>ff</i> → <i>mp</i> → <i>f</i> → <i>mp</i>			<i>pp</i> → <i>mf</i> → <i>pp</i> → <i>mp</i> Liv (sempre) [all the time with the piano]							
Celli	molto s.t. arco <i>mf</i>			molto s.p. [as high as possible] p							
Double Bass	arco <i>sfz</i>			molto s.t. → molto s.p. [col legno battuto] <i>mf</i> → <i>pp</i> [leg. sempre] <i>mf</i> → <i>pp</i> [sim sempre] <i>mf</i> → <i>pp</i>							

NB Gestures are not proportional to timeline

Figure 93: Principal gestural archetypes used in section D

Principal gestural archetypes used  
by the acoustic instruments

ELECTRONICS

Section E

	5'50"	6'00"	6'10"	6'20"	6'30"	6'40"	6'50"	7'00"	7'10"	7'20"	7'30"
Flute					air notes pp < mp > pp pizz.		air notes pp < mp > pp ord.				
Bass Clarinet					air notes pp	flz. mp		ord. pp		ord. pp	
Vibraphone					arco. l.v. (sempre) ppp (sempre) cresc.						
Piano			l.v. (sempre) ppp (sempre) 5.4			8" ppp < pp > ppp jitteroni over strings as fast as possible					
Cello		col legno tratto molto s.p. (sempre) ppp		col legno battuto ppp < pp			gliss.				pp
Double Bass		col legno tratto molto s.p. (sempre) ppp					gliss.				pp

NB Gestures are not proportional to timeline

Figure 94: Principal gestural archetypes used in section E

### Classification of gestural archetypes used

Table 7 shows the principal categories used to describe the gestural archetypes. The categories are again adapted from the typology suggested by Lewis and Pestova (Lewis & Pestova, 2012). Many of the archetypes used in the composition fall between categories and it is often these ambiguities that contribute to the compositional interest of the work.

**Table 7: Principal categories used for gestural archetypes**

Slow attack and continuation
Slow attack and abrupt decay
Iteration/push
Rapid burst and slow decay
Rapid burst and abrupt decay
Strike
Strike/push and continuation

In order to illustrate the way in which this terminology has been applied in the composition, examples are given below. Many of these examples are taken from the pre-compositional process but similar gestures can be found in the final work. Examples of archetypes used by the vibraphone are show in Figure 95 to Figure 101:

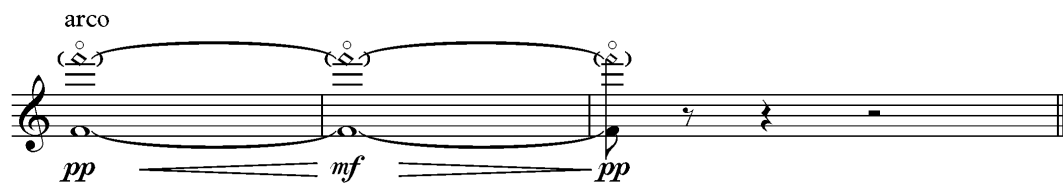

**Figure 95: Vibraphone gestural archetype 1. Slow attack and continuation: bowed note with harmonic**

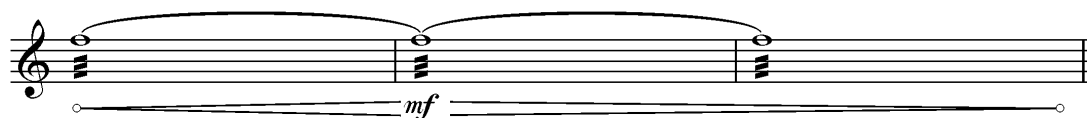

**Figure 96: Vibraphone gestural archetype 2. Iteration: rapidly repeated note**



Figure 97: Vibraphone gestural archetype 3. Short attack and decay - strike gesture

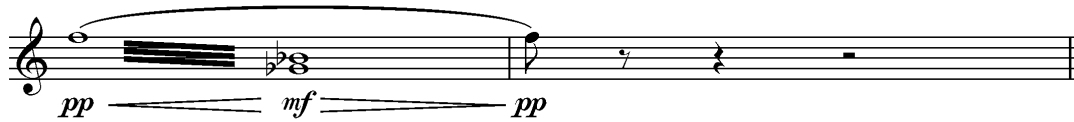

Figure 98: Vibraphone gestural archetype 4. Iteration 2 - push gesture

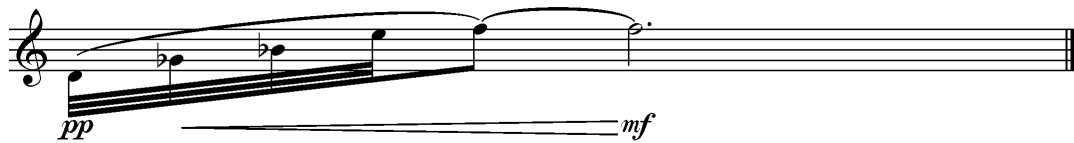

Figure 99: Vibraphone gestural archetype 5. Rapid burst and decay. Strike/push gesture

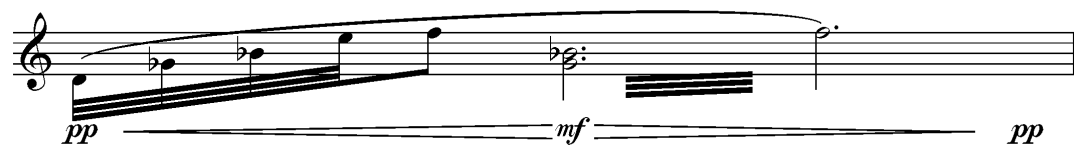

Figure 100: Vibraphone gestural archetype 6. Rapid burst and continuation. Strike/push and continuation

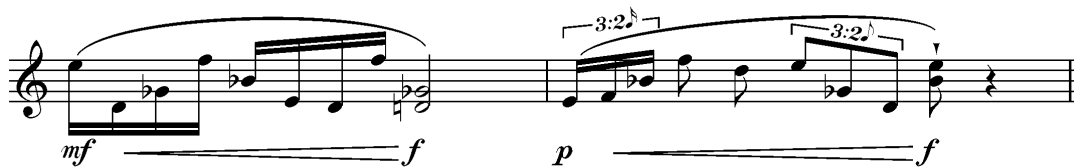

Figure 101: Vibraphone gestural archetype 7. Longer phrases with a mixture of regular and irregular rhythms. Mixture of slow decay and abrupt decay

Examples of the gestural archetypes used by the 'cello are shown in Figure 102 to Figure 109:



Figure 102: 'Cello gestural archetype 1. Slow attack and continuation: pure sound moving to noise and back through increased bow pressure

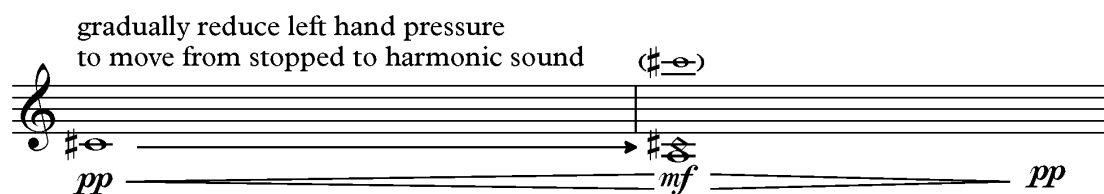

Figure 103: Variation of gestural archetype 1. Slow attack and continuation: gradually reducing finger pressure to move from stopped note to harmonic sound

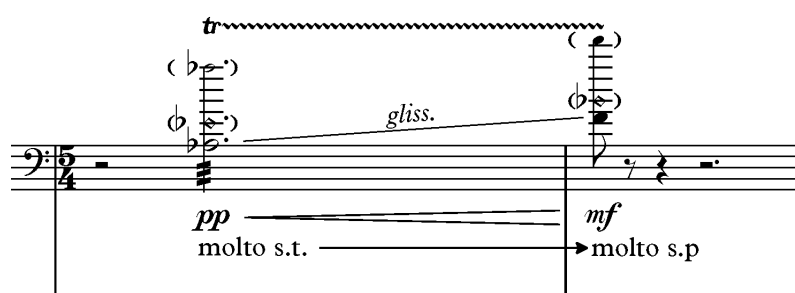

Figure 104: 'Cello gestural archetype 2. Iteration, rapidly repeated note: Harmonic perfect 5<sup>th</sup> above stopped note: trill between stopped note combined with glissandi. Pure sound moving towards noise through moving bow position from fingerboard to bridge

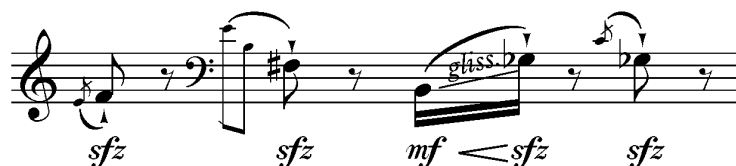

Figure 105: 'Cello gestural archetype 3. Short attack and decay



Figure 106: 'Cello gestural archetype 4: push gesture



Figure 107: 'Cello gestural archetype 5: rapid burst and decay: strike/push gesture

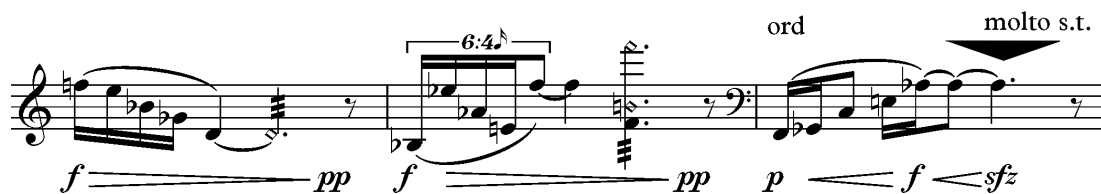

Figure 108: 'Cello gestural archetype 6: rapid burst and continuation: strike/push and continuation

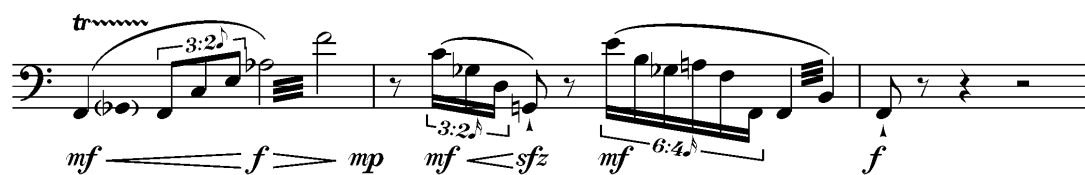

Figure 109: longer phrases with a mixture of regular and irregular rhythms: mixture of short and long decays

Examples of the gestural archetypes used by the double bass are shown in Figure 110 to Figure 116 (pitches are shown transposed up by one octave):



Figure 110: Double bass gestural archetype 1: slow attack and continuation: bowed note with and without harmonic

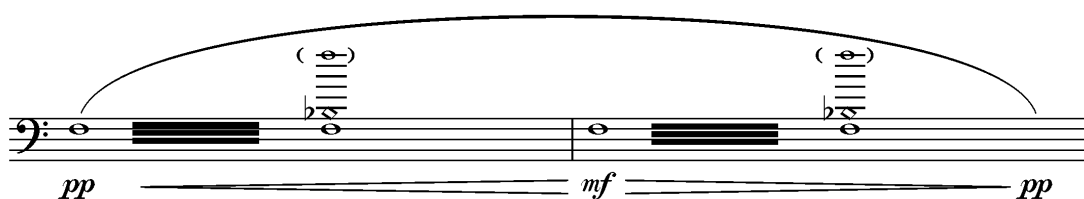

Figure 111: Double bass gestural archetype 2: iteration: tremolo between stopped note and artificial harmonic



Figure 112: Double bass gestural archetype 3: short attack and decay

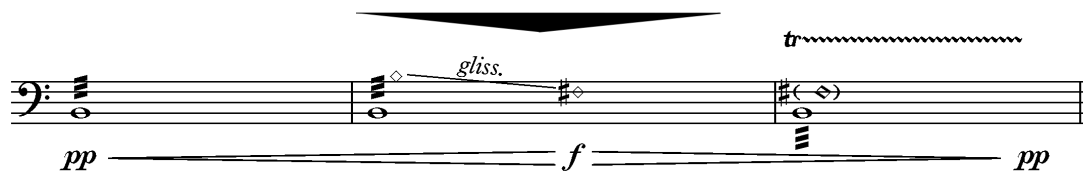

Figure 113: Double bass gestural archetype 4: iteration: push gesture



Figure 114: Double bass gestural archetype 5: rapid burst and decay: strike push gesture



Figure 115: Double bass gestural archetype 6: rapid burst and continuation: strike/push and continuation

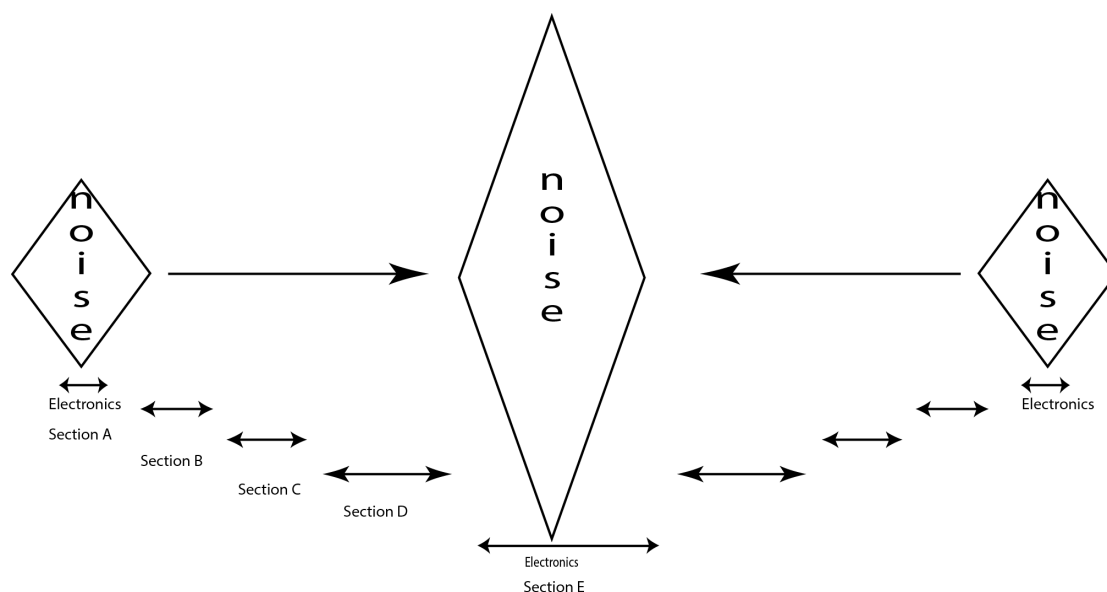

Figure 116: Double bass gestural archetype 7: longer phrases with irregular rhythms: mixture of short and long decays

The flute, the bass clarinet and the piano, use a similar taxonomy of gestures, examples of which can be found in Figure 90 to Figure 94.

### Electroacoustic Structure

The electroacoustic part engages in a dialogue with the acoustic instruments by moving through a similar structural framework. The electronic part is structured in such a way as to spread outward from the centre of each section of the composition. The extent of the electronics gradually increases with each section as the composition progresses so that, by the centre of the piece, the electronics are playing through the majority of the section. A broad outline of this process is shown in Figure 117.



**Figure 117: Broad schematic demonstrating how the extent of the electronic part gradually increases from the centre of each section until, by the centre of the composition, the electronics play throughout the majority of the section. The process is then reversed**

A schematic for the performance environment used for the electronic part is shown in Figure 30. Table 8 shows which parameters from the environment have been mapped for the composition together with the abbreviation used in the score and the schematics. The symbols used to display the parameters are essentially the same as those shown in Figure 39 to Figure 50. The symbols have had some minor modifications, however, to ensure that they display more clearly on the score and to show interpolations between parameters more clearly. These can be seen in the score.

**Table 8: Parameters used for the control of the electronic part together with abbreviation**

<b>Parameter</b>	<b>Abbreviation</b>
Grain Size	GS
Grain Density	GD
Play Back Speed (Time Stretch)	PBS
Pitch Shift	Pitch
Delay Modulation Effect (Comb Filter)	DMod
Individual parameters for Delay Modulation Effect	

• Frequency	Fq
• Phase components	P
• Delay Window Size	Win
• Feedback	Fb
• Balance	Bl
Spectral Delay Balance	SD

For each section of the composition, each of the three channels of the electronic performance environment processes a sound file of a gestural archetype played by an acoustic instrument in the same section. Figure 118 to Figure 120 show the overall schematics for each of the three channels as they develop over the course of the composition. Figure 121 to Figure 125 show more detailed schematics for each of the first five sections of the composition with the three individual channels grouped together. It is these schematics which have been mapped onto the score. After the fifth section, the structure is reversed.

As with the acoustic part of the composition, the material in the electroacoustic part moves broadly along an axis from pure sound at the beginning of the composition to noise at the centre of the composition before returning to pure sound at the conclusion of the work. The process is not linear, however, and, as with the acoustic part, this non-linearity is exploited in order to build tension and add compositional interest.

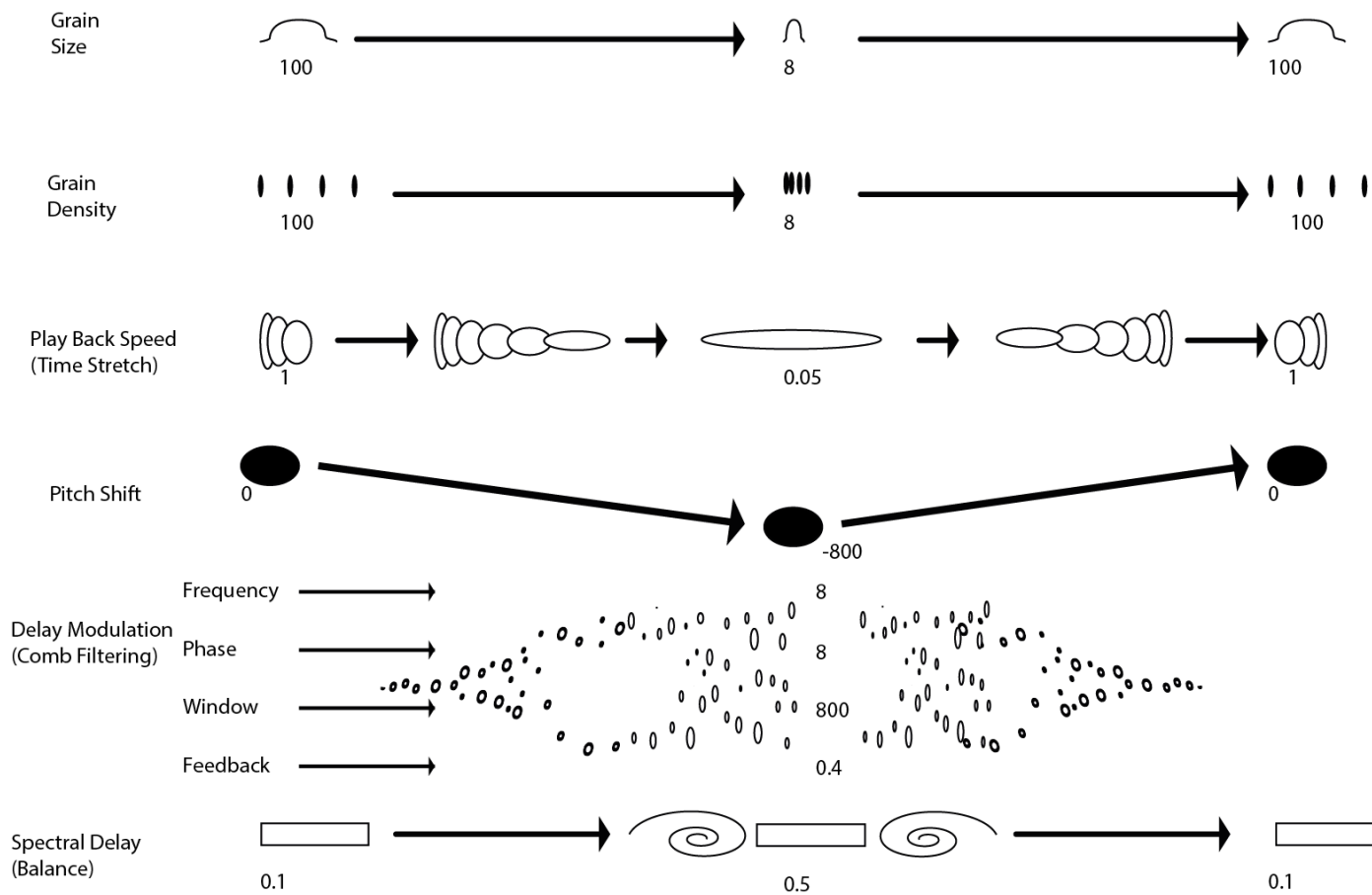

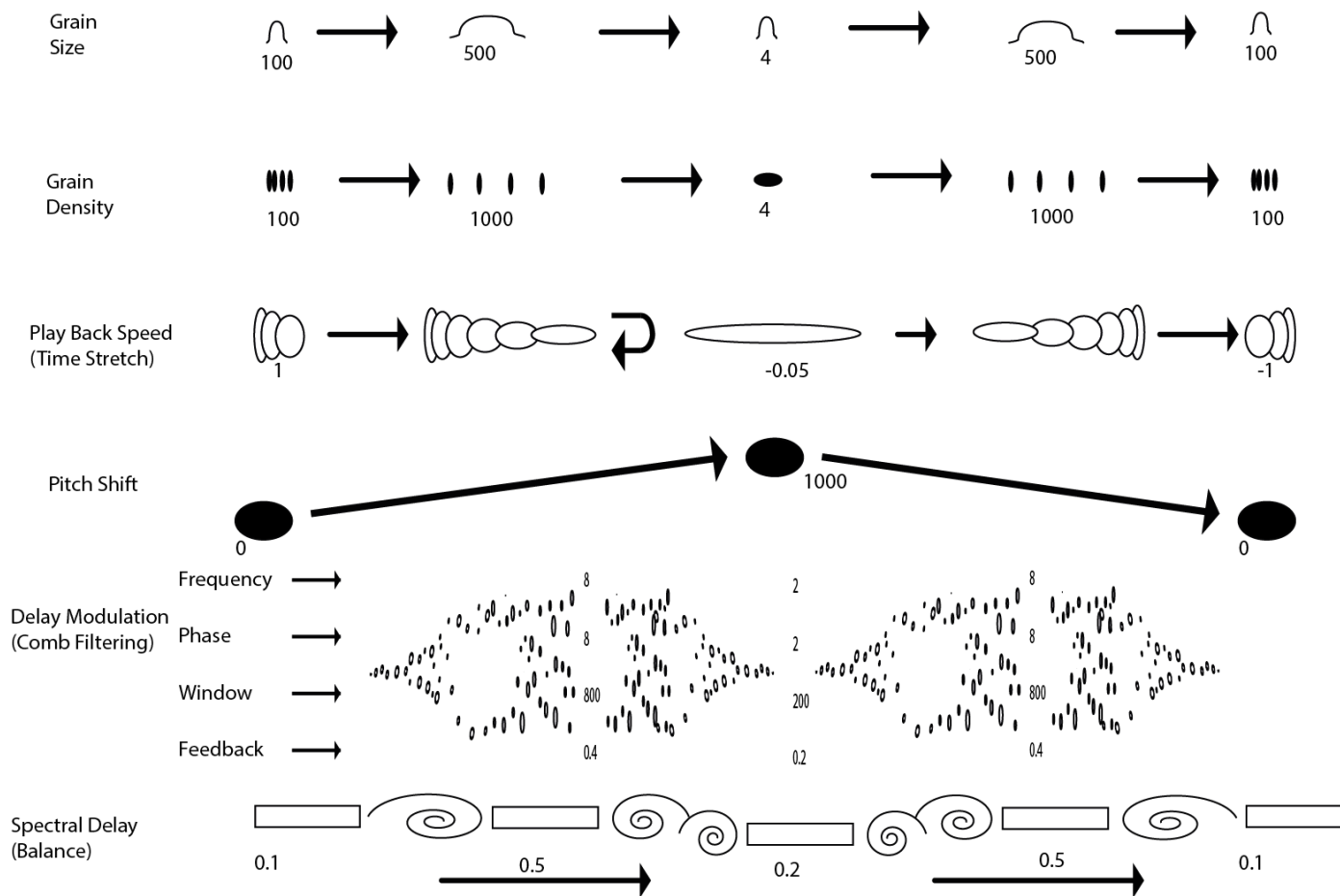

## Electronics Channel 2

Figure 119: Electronics channel 2 schematic

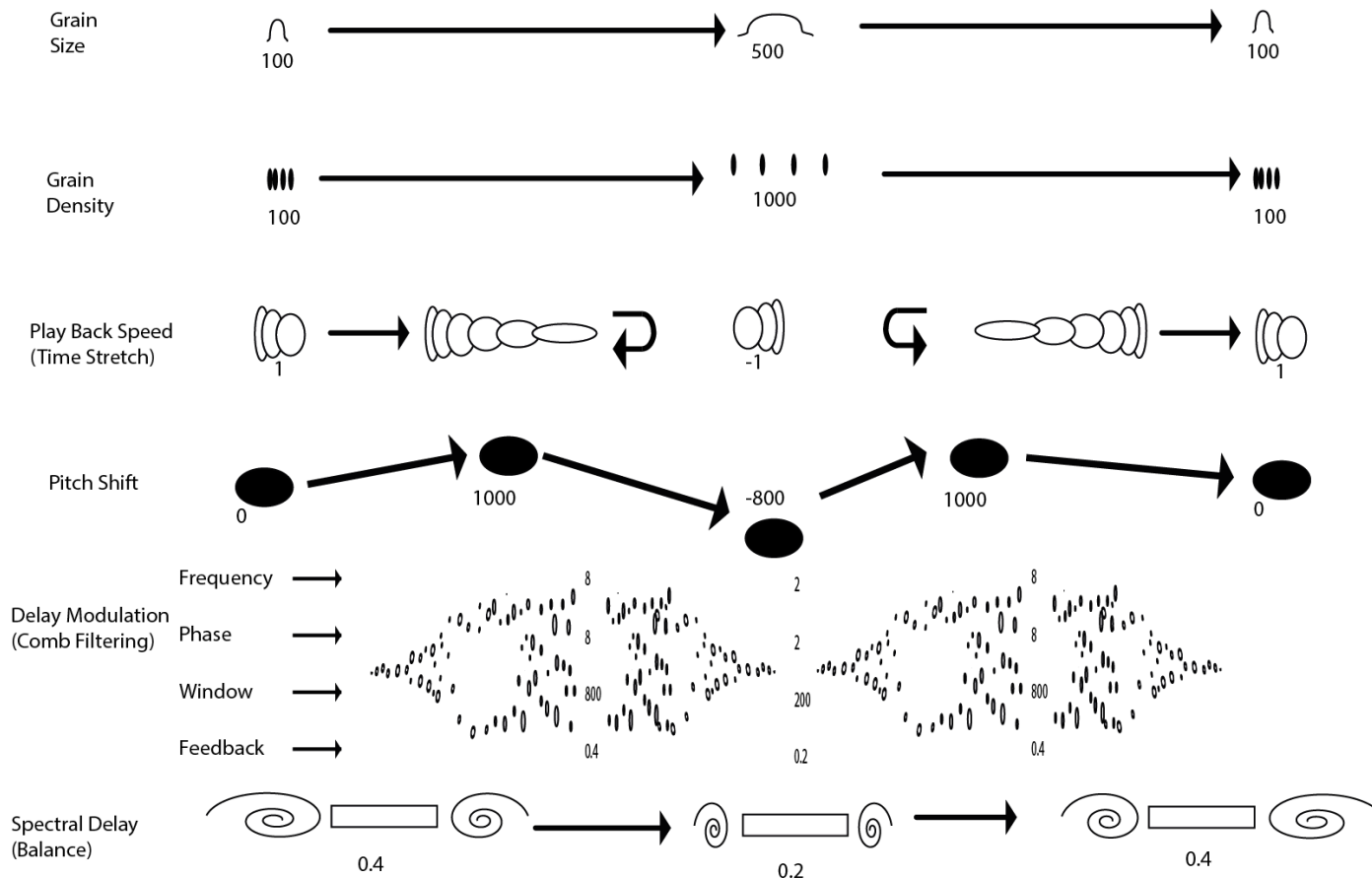

### Electronics Channel 3

Figure 120: Electronics channel 3 schematic

# Section A1

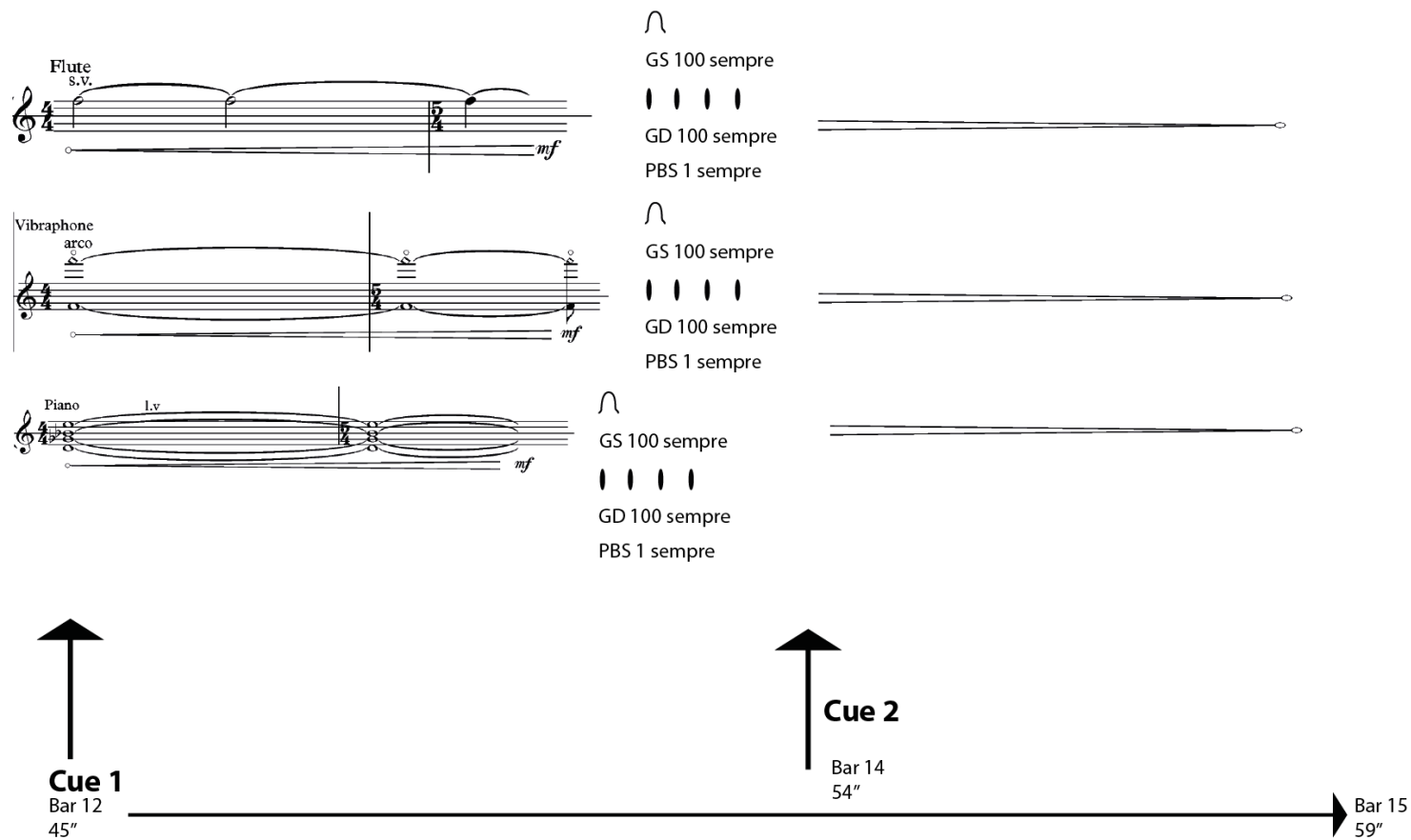

Figure 121: Electronics section A1 schematic

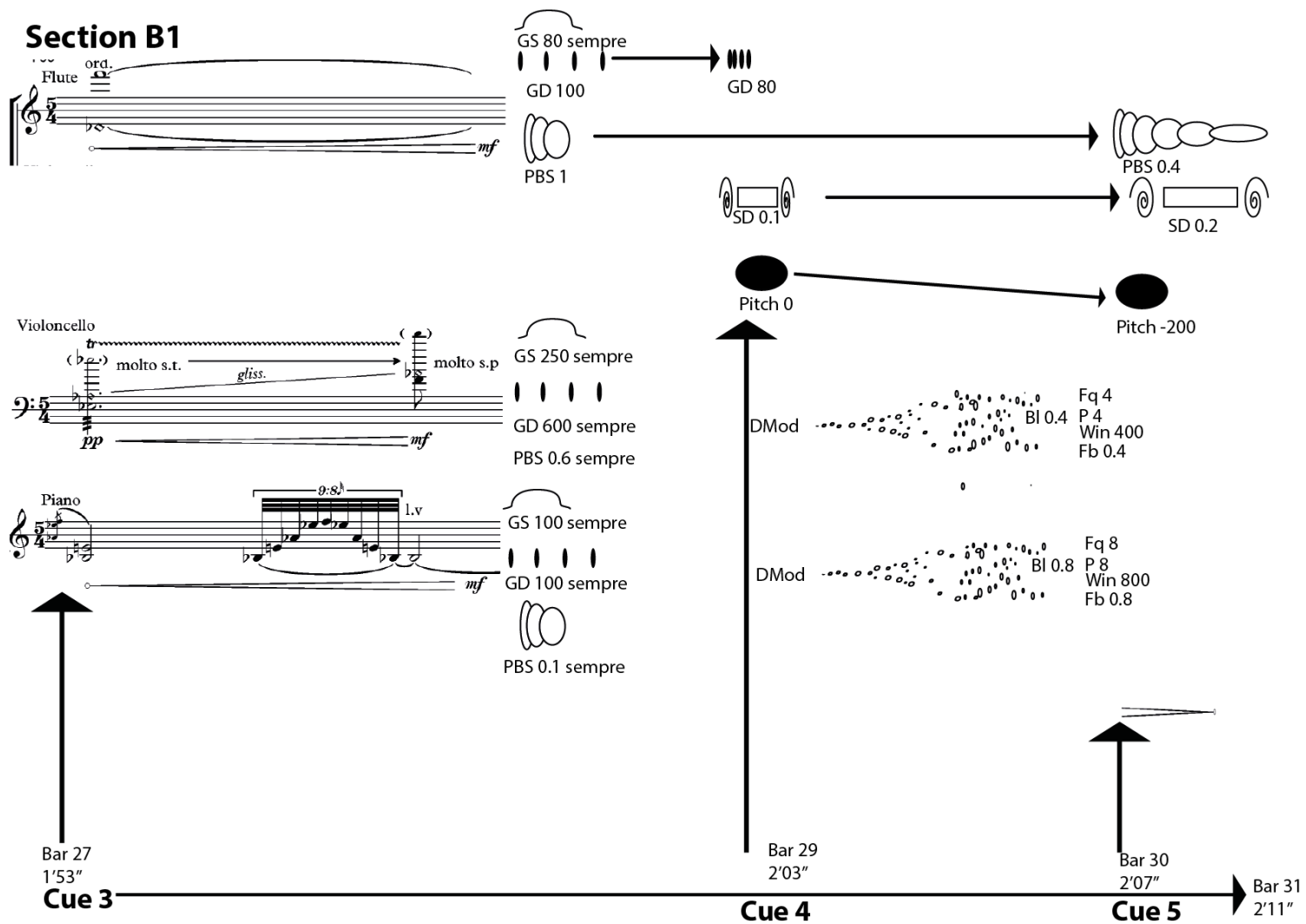

Figure 122: Electronics section B1 schematic

# Section C1

D.Bass *gliss.*



PBS 0.1 (sempre)



Pitch -600 (sempre)

DMod sempre  
 Fq 4  
 BI 0.4 P 4  
 Win 400  
 Fb 0.4

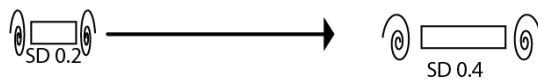

B. Clarinet



GS 500 sempre GD 250

GD 1000sempre



PBS 0.2 sempre



Pitch -400 (sempre)

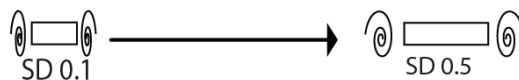

'Cello



GS 250 (sempre)

GD 250

GD 700

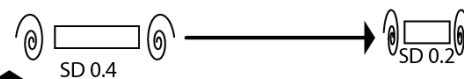

**Cue 6**  
 Bar 46  
 3'18"



**Cue 7**  
 Bar 49  
 3'32"



**Cue 8**  
 Bar 51  
 3'40"

Figure 123: Electronics section C1 schematic

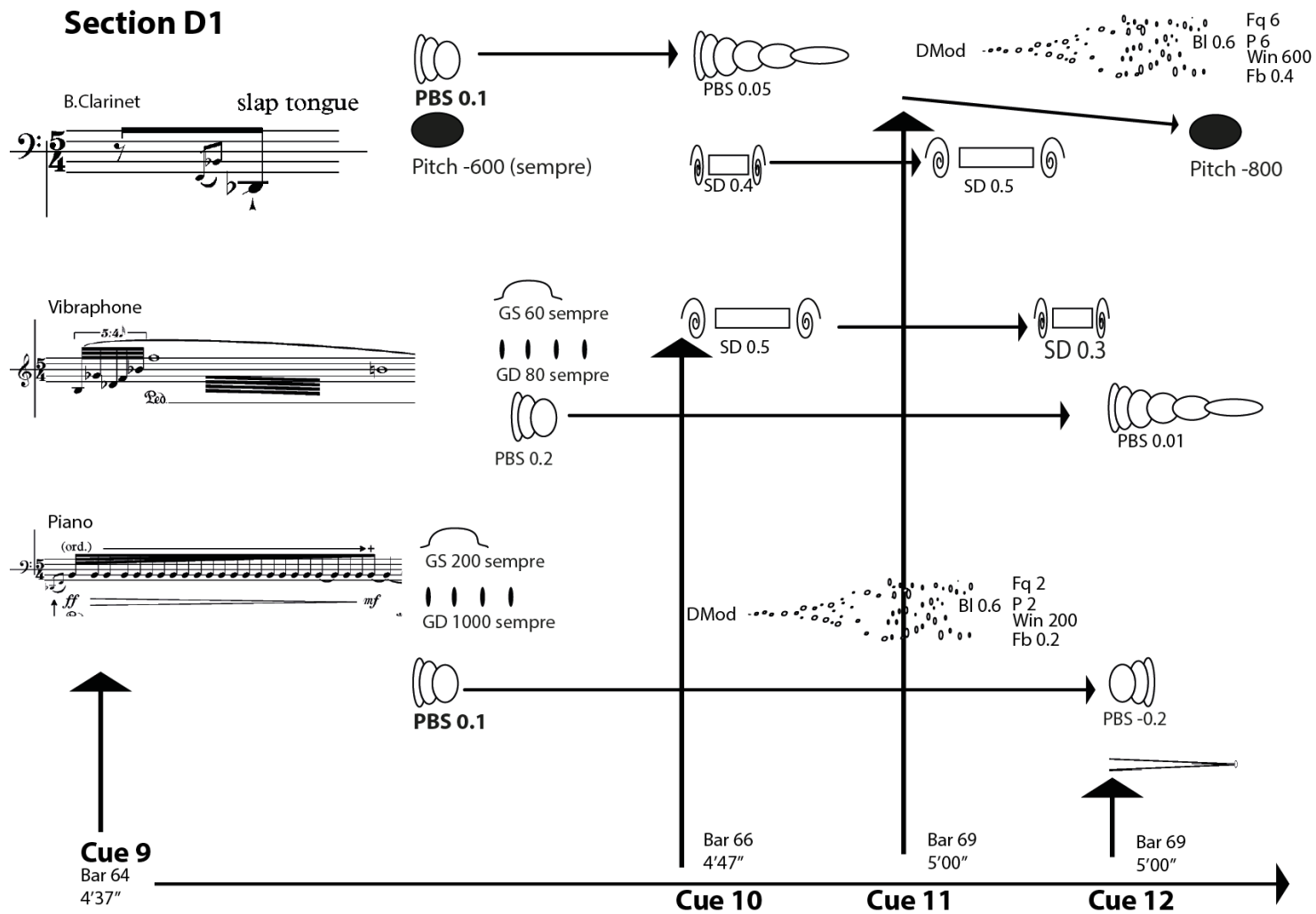

Figure 124: Electronics section D1 schematic

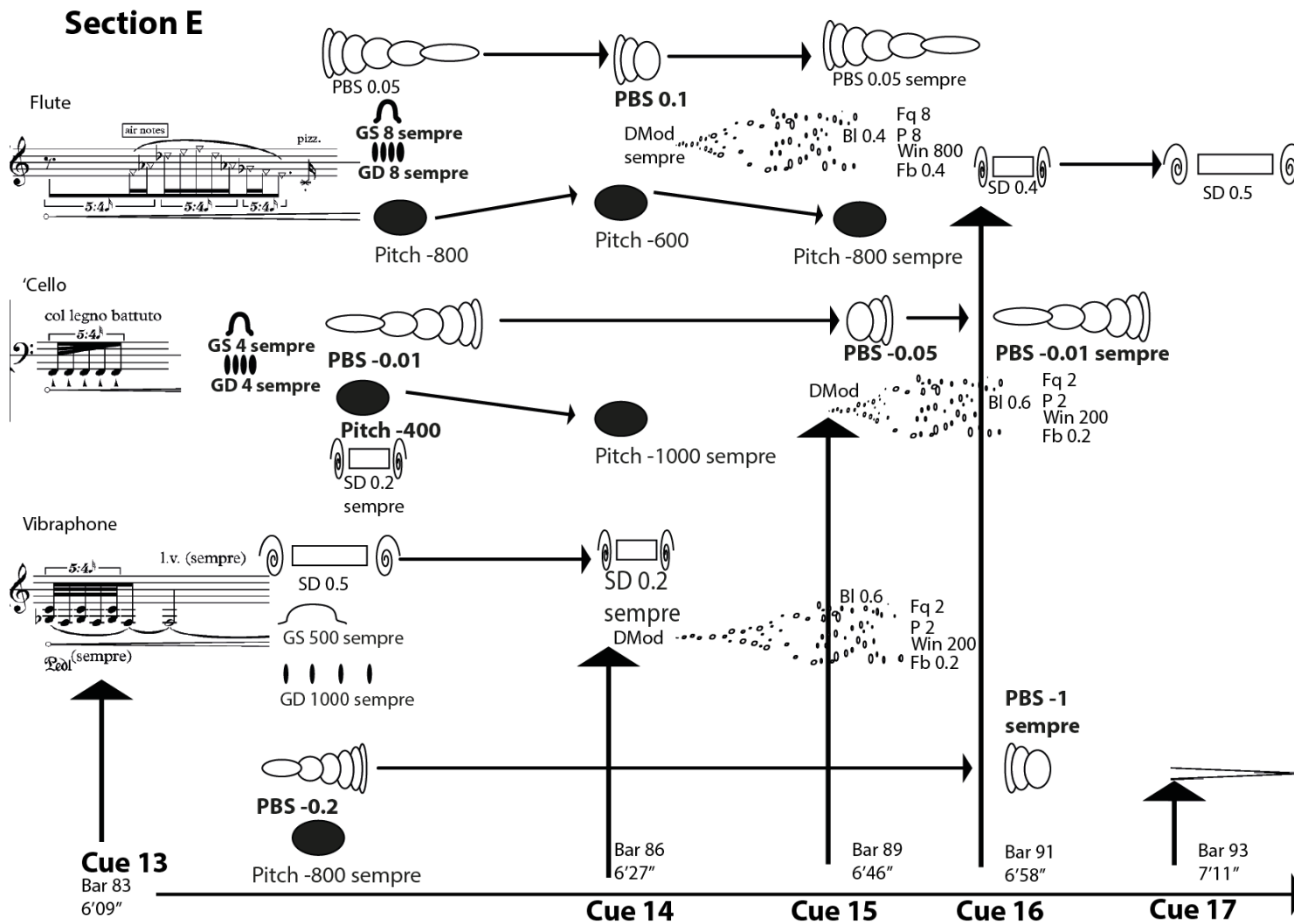

Figure 125: Electronics section E schematic

## **Creating a unified work through the application of multiple structural frameworks**

Owing to the multiple structural frameworks underpinning the composition, the disparate but interrelated elements of the work unfold separately but also as an integrated, cohesive whole. The harmonic structure, the hierarchy of gestural archetypes and the pure sound/noise axis all function together, in both the acoustic and the acousmatic elements, to create a unified composition. The broad macrostructures described in the schematics are reflected in the microstructures of the piece on different timescales. Progressions from pure sound to noise and back can be observed not only in the overall structure of the composition but also in individual sections, gestures, and microsound events.

As different parts of the work unfold, tensions, as well as resolutions to those tensions, appear not only between the electroacoustic parts and the acoustic parts but also within those parts themselves. In this respect, the electroacoustic material does not merely function as a way of extending or framing the acoustic part. Rather, both parts evolve simultaneously and both are interdependent and integral to the unfolding of the musical argument.

## **The implications of using a simple symbolic graphic notation system which is both prescriptive and descriptive**

The notation for the electroacoustic elements is both descriptive, in that it provides a useful representation of the processes, and prescriptive, in that it contains enough detail to allow the work to be reproduced with the appropriate software environment. The graphics used are intuitive to understand and easy to incorporate into commercial music processing packages. The use of graphics in this way, especially when they are intended to be used in works which incorporate acoustic instruments, encourages an approach to acousmatic composition where broad structural outlines, as well as more detailed gestures and phrases, can be imagined before any processing takes place. In this respect they function as an extremely useful compositional tool.

The composition functions well as an example of acoustic instruments combining with electroacoustic material through the application of microsound. The use of acoustic instruments as source material, the adoption of a system of hierarchical gestural archetypes, and carefully considered structural frameworks all serve to give the piece a cohesion in which the acousmatic and the acoustic interrelate in an aesthetically satisfying manner. Integrating cues from the software performance environment into the score functions well as a model for control of the electronic part. The system of notation is useful for both composition and analysis. The composition demonstrates well the use of microsound to mediate relationships between the acoustic and the acousmatic.

## **Conclusion: Discussion and Recommendations**

A principal aim of this research project has been to create a portfolio of compositions which use the affordances of microsound explicitly as a way of uniting an acoustic sound world with an electroacoustic sound world. The compositions in this portfolio thus illustrate the use of microsound as a compositional tool which extends and enhances the range of mixed acoustic and electroacoustic composition. This has been achieved by using microsound as a means of exploring the gestural and textural relationships which exist between the different domains. Microsound has also been used as a way to manipulate the perception of causal relationships and source bonding as the distinctions between the acoustic and the electroacoustic become ambiguous. This has been achieved through a detailed mapping of the source material to the compositional affordances of the electroacoustic performance environments in such a way that cohesive and coherent musical arguments emerge in which dialogues between seemingly disparate elements can produce aesthetically worthwhile results.

An important achievement of this research has been to address the challenge of establishing a suitable system of notation that accurately conveys the performance parameters of the composition, while at the same time describing the sounds in ways which are both meaningful and intuitive. This has resulted in the creation of a new system of graphical symbols which combine a descriptive approach with detailed performance parameters. Having a symbolic representation of the electroacoustic part on the same score as the acoustic part offers the composer of mixed acoustic and electroacoustic compositions a powerful tool for both composition and analysis. A potential area for further research would be to extend the range of symbols and apply them to a range of different processing techniques. One example of an area which could benefit from such an approach would be the use of concatenative synthesis in compositions for acoustic instruments and electronics.

Also discussed in chapter 5 were various models for controlling the software environments. The challenges presented by delegating responsibility for the control of the electronic part to the performers of the acoustic instruments

resulted in environments being adopted where a separate human controller of the electronic part would trigger pre-programmed cues. These cues, although pre-programmed, nonetheless included enough randomised parameters to introduce subtle but significant differences between performances. These ideas were developed in chapter 6. The most successful models for the control of the electronic parts in this context were the systems where pre-composed cues were combined with real time processing. These systems resulted in a satisfactory balance between compositional accuracy and the flexibility and unpredictability afforded by live electronics and real time processing. Any improvisational aspects of the compositions, both in the acoustic and the electroacoustic parts, were only truly satisfactory when they were carried out within very tightly constrained parameters. Similarly, where interactive interfaces were incorporated into the compositions, the results were partially successful but again boundaries for improvisation needed to be very carefully defined. This approach to composition and performance adds to the existing repertoire of compositions for acoustic instruments with electronics by combining the control of the software using pre-composed cues executed in real time with careful control of the boundaries for improvisation in the acoustic part in the context of microsound.

A further challenge, discussed in chapter 3, was to create perceptual continua between acoustic and acousmatic sounds. The use of extended techniques proved to be an effective means of extending the range of the acoustic instruments into the acousmatic. Perceptual continua emerged in which source bonding became weakened and levels of gestural surrogacy moved towards the remote. Incorporating these techniques into structural frameworks based on pure sound/noise axes and gestural hierarchies allowed the acousmatic and the acoustic to interrelate in intriguing ways. Complex networks of relationships emerged with the illusion of acoustic energy passing from one realm to the other. Careful control of the parameters of the software environments resulted in the electroacoustic sounds following similar trajectories. The different structural frameworks proposed in chapters 3, 6 and 7 offered a variety of templates for the manipulation of material on a variety of structural levels. It is the particular

synthesis of these different elements in the context of this project that builds upon existing works and contributes a new perspective on the use of microsound in compositions for acoustic instruments and electronics.

The systematic use of microsound as the primary guiding aesthetic principle for the production of this portfolio also adds to and extends the existing body of work in this area. Possible extensions to this research area include the application of spatialisation techniques in this context and the extension of the repertoire of techniques to other microsound processes such as concatenative synthesis. The use of pre-programmed cues for the control of the electronic part in many of the compositions in this portfolio suggests that the adaption of the material to incorporate score following algorithms, such as IRCAM's Antescofo (IRCAM, 2007-2012), would be another interesting area for further research.

The compositions in this portfolio develop from and enhance the existing body of work in that the application of microsound as a technique has been used explicitly to blur distinctions and emphasise connections, dependencies and interrelationships between sounds in both the acoustic and electronic domains. The application of the technique in this context has added to the use of granulation in the live sphere. The use of carefully considered structural frameworks, for both the acoustic and the electroacoustic parts, has resulted in a portfolio of compositions where influences and transformations between the acoustic and the electronic have been mediated through the use of microsound in such a way as to contribute a new perspective on the existing body of work. Furthermore, using the output of the acoustic instruments, specifically in the context of microsound, as the source material for the electronics in such a way that it is always possible to perceive that output, however remotely, in the electroacoustic part is another useful addition to the existing repertoire. Careful consideration of both the control and the notation of the electronic part has also been an important factor in the production of this portfolio. The result is a portfolio of compositions which builds upon existing approaches and develops fresh contexts for the application of microsound in compositions for acoustic instruments and electronics.

## Bibliography

- Adkins, M. (1999). *Acoustic Chains in Acousmatic Music*. Retrieved June 10, 2015, from eprints.hud.ac.uk:  
[http://eprints.hud.ac.uk/4273/1/Acoustic\\_Chains\\_in\\_Acoustic\\_Music.pdf](http://eprints.hud.ac.uk/4273/1/Acoustic_Chains_in_Acoustic_Music.pdf)
- Antares. (2011). *Antares Autune*. Retrieved 2011 16-June from Auto-Tune 7:  
<http://www.antarestech.com/products/auto-tune-7.shtml>
- Apple. (2011). *iPad2*. Retrieved 2011 2-August from www.apple.com:  
[www.apple.com/uk/ipad](http://www.apple.com/uk/ipad)
- Apple. (2011-b). *Logic Express 9 Instruments - the Vocoder*. Retrieved 2011 16-June from Apple Logic 9 Documentation:  
<http://documentation.apple.com/en/logicexpress/instruments/index.html#chapter=7%26section=10%26tasks=true>
- Assayag, G. (1999). Computer assisted composition at IRCAM: from Patch Work to Open Music. *Computer Music Journal*, 23 (3).
- Austen, L., & Smalley, D. (2000). Sound Diffusion in Composition and Performance; An Interview with Denis Smalley. *Computer Music Journal*, 24 (2), 10-21.
- Benson, A. (2013). *Signal Rate Utilities*. Retrieved April 30, 2014, from www.cycling74.com: <http://cycling74.com/toolbox/benson-signal-rate-utility/>
- Bledsoe, H. (2012). *Some Basic Extended Techniques*. Retrieved April 12, 2014, from helenbledsoe.com: <http://helenbledsoe.com/?cat=18>
- Boudon, O. (2000). Composing with Objects, Networks and Timescales: An Interview with Horacio Vaggione. *Computer Music Journal*, 24 (3), 9-22.
- Boulez, P. (1986). Le Système et l'idée. *Inharmoniques*, 1.
- Boulez, P. (Composer). (1999). Répons. [P. E. Intercontemporain, Performer] *On Répons et dialogue de l'ombra double* [CD]. 20/21.
- Boulez, P. (1987). Timbre and Composition: Tmbre and Language. *Contemporary Music Review*, 2 (1), 161-171.
- Burkhart, C. (1973). Schoenberg's Farben: An analysis of Opus 16 No. 3. *Perspectives of New Music*, 12 (1/2), 141-172.
- Cadoz, C. (1988). Instrumental Gesture and Musical Composition. *International Computer Music Conference*. Cologne.
- Callum, P., & Boulez, P. (1989). An Interview with Pierre Boulez. *Musical Times*, 130 (1751), 8-10.
- Centatus Music Projects. (2010). *Perspectives on Digital Music*. (C. C. Music, Producer) Retrieved June 13, 2013, from Simon Emmerson on Live Computer Music:  
[http://www.youtube.com/watch?v=78z1\\_8J8oVE&list=PL1F3E1670267BD65E&index=11](http://www.youtube.com/watch?v=78z1_8J8oVE&list=PL1F3E1670267BD65E&index=11)
- Charles, J. F. (2008). A Tutorial on Spectral Sound Processing using Max MSP and Jitter. *Computer Music Journal Vol 32 No 3*, 87-102.
- CNMAT. (2012). *Center for New Music and Audio Technologies*. Retrieved 2012 24-April from University of California, Berkeley:  
<http://cnmat.berkeley.edu/downloads>
- Collins, N. (2009). Musical Form and Algorithmic Composition. *Contemporary Music Review*, 28 (1), 103-114.

Collins, N. (2011). *Listening and Learning in an Interactive Improvisation System*. Retrieved 2012 7-April from [www.sussex.ac.uk](http://www.sussex.ac.uk):  
<http://www.sussex.ac.uk/Users/nc81/code.html>

Cont, A. (2008). Antescofo: Anticipatory synchronisation and control of interactive parameters in computer music. *Proceedings of the International Computer Music Conference*. Belfast: ICMA.

Cont, A. (2010). *Musical Synchrony*. Retrieved 2012 22-April from IRCAM-MRT:  
<http://repmus.ircam.fr/antescofo/videos>

Cox, G. (2010). A Return to the Future or Forward to the Past? *Contemporary Music Review*, 29 (3), 251-264.

Dhomont, F. (Composer). (2002). Espace/Escape (1989). On *Acousmatix - The History of Electronic Music VIII - IX* [CD]. BV Haast.

Di Scipio, A. (1994). Micro-Time Sonic Design and Timbre Formation. *Contemporary Music Review*, 10 (2), 135-148.

Di Scipio, A. (1995). Inseparable Models of Materials and of Musical Design in Electroacoustic and Computer Music. *Journal of New Music Research*, 24, 34-50.

Di Scipio, A. (1996). *Interactive Composing with Granular Time-shifting of Sound*. Retrieved January 28, 2016, from IRCAM Repmus: 3emes Journées d'Informatique Musicale. JIM96:

Di Scipio, A. (1998). Compositional Models in Xenakis' Electroacoustic Music. *Perspectives of New Music*, 36 (2), 201-243.

Di Scipio, A. (2004). The Orchestra as a Resource for Electroacoustic Music on Some Works By Iannis Xenakis and Paul Dolden. *Journal of New Music Research*, 33 (2), 173-183.

Di Scipio, A. (2005). Formalization and Intuition in Analogique A et B. *International Symposium Iannis Xenakis Conference Proceedings*, (pp. 95 - 108). Athens.  
<http://recherche.ircam.fr/equipes/repmus/jim96/actes/discipio/discipio.html>

Dick, R. (1989). *The Other Flute*. Multiple Breath Music Company.

Dimpker, C. (2013). *Extended notation; the depiction of the unconventional*. Retrieved February 19, 2016, from Pearl, Plymouth electronic archive and research library: <https://pearl.plymouth.ac.uk/handle/10026.1/3184>

Dobrian, C. (2002). Aesthetic Considerations in the Use of "Virtual" Musical Instruments. *SEAMUS Journal*, 16 (2), 28-33.

Dolson, M. (1986). The Phase Vocoder: A Tutorial. *Computer Music Journal*, 10 (4), 14-27.

Drummond, J. (2009). Understanding Interactive Systems. *Organised Sound*, 14 (2), 124 - 133.

Dudas, R., & Lippe, C. (2006). *The Phase Vocoder Part 1*. Retrieved 2011 11-February from Cycling 74: [www.cycling74.com](http://www.cycling74.com)

Emmerson, S. (2001). From Dance! to "Dance": Distance and Digits. *Computer Music Journal*, 25 (1), 13-20.

Emmerson, S. (1986). The Relation of Language to Materials. In S. Emmerson, *The Language of Electroacoustic Music* (pp. 17-40). MacMillan.

Emmerson, S. (1989). Composing Strategies and Pedagogy. *Contemporary Music Review*, 3, 133-144.

Emmerson, S. (1998). Acoustic/Electroacoustic: The relationship with instruments. *Journal of New Music Research*, 27 (1-2), 146-164.

Emmerson, S. (2007). *Living Electronic Music*. Ashgate.

Emmerson, S., & Leigh, L. (2012). The analysis of electroacoustic music, the differing needs of its genres and categories. *Electroacoustic Studies Network Conference. Meaning and Meaningfulness in Electroacoustic Music*. Stockholm: www.ems-network.org.

Fischman, R. (2008). Mimetic Space Unravelling. *Organised Sound*, 13 (2), 111-122.

Flanagan, J., & Golden, R. (1966). Phase Vocoder. *Bell System Technical Journal*, 45, pp. 1493-1509.

Gayou, E. (2006). Analysing and Transcribing Electroacoustic Music: the experience of the Portraits polychromes of GRM. *Organised Sound*, 11 (2), 125-130.

Gibson, J. (1979). *The Ecological Approach to Visual Perception*. Psychology Press.

Godoy, R. I. (2006). Gestural Sonorous Objects: embodied extensions of Schaeffer's conceptual apparatus. *Organised Sound*, 11 (2), 149-157.

Goldman, J. (2011). *The Musical Language of Pierre Boulez*. Cambridge.

Gritten, A., & King, E. (2006). *Music and Gesture*. Ashgate Publishing Group.

Hagan, K. (2005). *Genetic Analysis of Analogique B*. Retrieved 2011 12-November from Website of the Electroacoustic Music Studies Network: <http://www.ems-network.org/spip.php?rubrique34>

Hamel, K. (2000-2007). *Note Ability Pro Music Notation Software*. Retrieved 2012 21-April from Debussymusic.ubc.ca: <http://debussy.music.ubc.ca/NoteAbility/index.html>

Harley, J. (1999). *An integrated granular approach to algorithmic composition for instruments and electronics*. Retrieved January 17, 2016, from Journées d'Informatique Musicale '99: [https://www.academia.edu/3415635/An\\_integrated\\_granular\\_approach\\_to\\_algorithmic\\_composition\\_for\\_instruments\\_and\\_electronics](https://www.academia.edu/3415635/An_integrated_granular_approach_to_algorithmic_composition_for_instruments_and_electronics)

Harley, J. (2002). The Electroacoustic Music of Iannis Xenakis. *Computer Music Journal*, 26 (1), 33-57.

Harley, J. (2004). *Xenakis, His Life in Music*. New York and London: Routledge.

Harley, M. A. (1994). Spatial Sound Movement in the Instrumental Music of Iannis Xenakis. *Journal of New Music Research*, 23 (3), 291-314.

Harrison, J. (1998). Sound, space, sculpture: Some thoughts on the what, how, and why of sound diffusion. *Organised Sound* (3), 117-127.

Harvey, J. (1986). Madonna of Winter and Spring. *Musical Times*, 127 (1720), 431-433.

Hayden, S., & Kanno, M. (2011). Towards musical interaction; Sam Hayden's schismatics for e-violin and computer. *Proceedings of the International Computer Music Conference*. ICMA.

Henken, J. (2014). *Metastaseis*. Retrieved January 15, 2015, from LA Phil: <http://www.laphil.com/philpedia/music/metastaseis-iannis-xenakis>

Henken, J. (2014). *Metastaseis*. Retrieved January 15, 2015, from LA Phil: <http://www.laphil.com/philpedia/music/metastaseis-iannis-xenakis>

Hirs, R. (2009). *Contemporary composition techniques and Open Music*. Retrieved April 11, 2014, from Rozalie.com: [http://www.rozalie.com/2A\\_essay.htm](http://www.rozalie.com/2A_essay.htm)

Hockings, E. (1995). Helmut Lachenmann's Concept of Rejection. *Tempo, New Series*, 193 (German Issue), 4-10+12-14.

Hospers, J. (1997). *An Introduction to Philosophical Analysis* (4th Edition ed.). Routledge.

Hsu, W. (2010). Strategies for Managing Timbre and Interaction in Automatic Improvisation Systems. *Leonardo Music Journal*, 20, 33-39.

Ihde, D. (2007). *Listening and Voice: Phenomenologies of Sound*. Suny Press.

IRCAM. (2007-2012). *Antescofo*. Retrieved 2012 21-April from IRCAM-Musical Representations Team: <http://repmus.ircam.fr/antescofo>

IRCAM. (2011). *AudioSculpt*. Retrieved 2011 16-February from IRCAM Forumnet: <http://forumnet.ircam.fr/691.html?L=1>

IRCAM. (2014). *CataRT: Real Time Corpus Based Concatenative Synthesis*. Retrieved June 26, 2015, from IRCAM imtr: <http://imtr.ircam.fr/imtr/CataRT>

IRCAM. (2016). *Jean-Claude Risset Attracteurs étranges*. Retrieved February 16, 2016, from BRAHMS Ressources.IRCAM: <http://brahms.ircam.fr/works/work/21304/>

IRCAM. (1998-2013). *Open Music: A visual programming environment for computer assisted composition*. Retrieved April 2, 2014, from IRCAM Forumnet: <http://forumnet.ircam.fr/product/openmusic/>

Kim, R. (2000). *Iannis Xenakis's Bohor (1962)*. Retrieved January 3, 2015, from Masterpieces of 20th Century Electronic Music: A Multimedia Perspective: <http://www.music.columbia.edu/masterpieces/>

Lachenmann, H. (1995). On Structuralism. *Contemporary Music Review*, 12 (1), 93-102.

Lachenmann, H. (1999). Touched by Nono. *Contemporary Music Review*, 18 (1).

Lewis, A., & Pestova, X. (2012). The Audible and the Physical; a Gestural Typology for "Mixed" Electronic Music. *Proceedings of the Electroacoustic Music Studies Network Conference; Meaning and Meaningfulness in Electroacoustic Music*. Stockholm: [www.ems-network.org](http://www.ems-network.org).

Lippe, C. (2002). Real time Interaction Amongst Composers, Performers and Computer Systems. *Information Processing Society of Japan*. 123, pp. 1-6. SIG Notes.

Lippe, C., & Settel, Z. (2003). Convolution Brothers Instrument Design. *Conference on New Instruments for Musical Expression* (pp. 197-200). Montreal: NIME03.

Möller, M. (2005). *New Sounds for Flute*. Retrieved April 12, 2014, from sfz.se: <http://www.sfz.se/flutetech/>

Magnusson, T. (2009). Of Epistemic Tools: Musical Instruments as Cognitive Extensions. *Organised Sound*, 168-176.

Magnusson, T. (2010). Designing Constraints: Composing and Performing with Digital Music Systems. *Computer Music Journal*, 34 (4), 62 - 73.

McCloskey, B. (2011, September 14). *FCast*. Retrieved April 16, 2014, from Granulation Synthesis in Max MSP: <http://brendan-admi.blogspot.co.uk/2011/09/sharing-granulation-synthesis-in-maxmsp.html>

McMurtery, J. (2013). *Extended techniques*. Retrieved April 12, 2014, from [johnmcmurtery.com](http://johnmcmurtery.com): <http://johnmcmurtery.com>

McNutt, E. (2003). Performing Electroacoustic Music: A Wider View of Interactivity. *Organised Sound*, 8 (3), 297-304.

Mead, P. (2011). *A New Universe of Piano Sound*. Retrieved October 16, 2014, from University of Hertfordshire: <http://uhra.herts.ac.uk/handle/2299/11677>

Miranda, E., & Brouse, A. (2005). Toward Direct Brain-Computer Musical Interfaces. *International Conference on New Interfaces for Musical Expression*, (pp. 216-219). Vancouver, BC, Canada.

- Miranda, E., & Wanderley, M. (2006). *New Digital Musical Instruments: Control and Interaction Beyond the Keyboard*. Middleton, Wisconsin: A-R Editions Inc.
- Moon, B. (1997). *Interact 1*. Retrieved 2012 14-April from [barrymoon.com: http://www.barrymoon.com/wp-content/uploads/2011/04/interact1.pdf](http://www.barrymoon.com/wp-content/uploads/2011/04/interact1.pdf)
- Moscovich, V. (1997). French Spectral Music: an Introduction. *Tempo (New Series)* (200), 21-28.
- Murail, T. (2005). Spectra and Sprites. *Contemporary Music Review*, 24 (2-3), 137-147.
- Murail, T. (2005). The Revolution of Complex Sounds. *Contemporary Music Review Vol 24 No 2/3*, 121-135.
- Murail, T. (2005). The Revolution of Complex Sounds. *Contemporary Music Review*, 24 (2-3), 121-135.
- Native Instruments. (1996 - 2011). *Absynth 5*. Retrieved 2011 28-July from Native Instruments: <http://www.native-instruments.com/#/en/products/producer/absynth-5/>
- Native Instruments. (1996 - 2011). *Massive*. Retrieved 2011 2-August from Native Instruments: <http://www.native-instruments.com/#/en/products/producer/massive/>
- Newton, D., & Marshall, M. Examining How Musicians Create Augmented Musical Instruments. *Proceedings of the 11th International Conference on New Interfaces for Musical Expression*. Norway.
- Norman, D. (1988). *The Design of Everyday Things*. Basic Books.
- Norman, D. (1999). Affordance, Conventions, and Design. *Interactions*, 6 (3), 38-41.
- O'Callaghan, J., & Eigenfeldt, A. (2010). *Gesture Transformation Through Electronics in the Music of Kaija Saariaho*. Retrieved January 6, 2015, from [ems-network.org](http://www.ems-network.org): [http://www.ems-network.org/IMG/pdf\\_EMS10\\_OCallaghan\\_Eigenfeldt.pdf](http://www.ems-network.org/IMG/pdf_EMS10_OCallaghan_Eigenfeldt.pdf)
- Orning, T. (2012). Pression a performance study. *Music Performance Research*, 5, 12-31.
- Patton, K. (2007). Morphological Representation for Interactive Electroacoustic Music. *Organised Sound*, 12 (2), 123-128.
- Pousset, D. (2000). The works of Kaija Saariaho, Philippe Hurel and Marc- André Dalbavie—Stile concertato, stile concitato, stile rappresentativo. *Contemporary Music Review*, 19 (3), 67-110.
- Röbel, A. (2006). *Analysis/Resynthesis with Short Time Fourier Transform*. Retrieved 2011 14-February from Ircam: [http://recherche.ircam.fr/equipes/analyse-synthese/roebel/amt\\_audiosignale/VL2.pdf](http://recherche.ircam.fr/equipes/analyse-synthese/roebel/amt_audiosignale/VL2.pdf)
- Ramstein, C. (1991). *Analyse, Représentation, et Traitement du Geste Instrumental*. PhD Thesis: Institut National Polytechnique de Grenoble. Retrieved 2011 2-August from TEL: <http://tel.archives-ouvertes.fr/tel-00340367/en/>
- Rebelo, P. (2010). Notating the Unpredictable. *Contemporary Music Review*, 29 (1), 17-27.
- Rizzardi, V. (1999). Notation, oral tradition and performance practice in the works with tape and live electronics by Luigi Nono. *Contemporary Music Review*, 18 (1).
- Roads, C. (1978). Granular Synthesis of Sound. *Computer Music Journal*, 2 (2), 61-62.

- Roads, C. (1988). Introduction to Granular Synthesis. *Computer Music Journal*, 12 (2), 11-13.
- Roads, C. (2001). *Microsound*. Cambridge, Massachusetts: MIT Press.
- Roads, C. (2005). The Electroacoustic Music of Horacio Vagione. *Contemporary Music Review*, 24 (4/5), 295-309.
- Roads, C. (2015). *Composing Electronic Music: A New Aesthetic*. OUP.
- Rofe, M. (2014). Dualisms of Time. *Contemporary Music Review*, 33 (4), 341-354.
- Roulette Intermedium. (2010, April 15). *An Interview with Christian Wolff*. Retrieved April 8, 2014, from Roulette TV on Vimeo: <http://vimeo.com/10954656>
- Saariaho, K. (1987). Timbre and harmony: Interpolations of timbral structure. *Contemporary Music Review*, 2 (1), 93-133.
- Schachter, D. (2007). Towards new models for the construction of interactive electroacoustic music discourse. *Organised Sound*, 12 (1), 67-78.
- Schaeffer, P. (1966). *Traite des Objets Musicaux* (2002 ed.). Seuil.
- Schultz, R. (2008, April 13). *All he asks is: "Try to like it" An interview with Helmut Lachenmann*. Retrieved October 14, 2014, from LA Times: <http://www.latimes.com/entertainment/la-ca-helmut13apr13-story.html#page=1>
- Schwarz, D. (2004). *Data Driven Concatenative Sound Synthesis*. Retrieved June 26, 2015, from IRCAM - Recherche: <http://recherche.ircam.fr/equipes/analyse-synthese/schwarz/thesis/>
- Smalley, D. (1997). Spectromorphology: explaining sound shapes. *Organised Sound*, 2 (2), 107-126.
- Smalley, D. (2007). Space-form and the acoustic image. *Organised Sound*, 12 (1), 35-38.
- Smith, J. (2010). *Short Term Fourier Transform in Spectral Audio Signal Processing*. Retrieved 2011 17-January from Center for Computer Research in Music and Acoustics (CCRMA), Stanford University: [https://ccrma.stanford.edu/~jos/sasp/Short\\_Time\\_Fourier\\_Transform.html](https://ccrma.stanford.edu/~jos/sasp/Short_Time_Fourier_Transform.html)
- Smith, R., & Murail, T. (2000). An Interview with Tristan Murail. *Computer Music Journal Vol 24 No 1*, 11-19.
- Stockhausen, K. (2004). Electronic and Instrumental Music. In C. Cox, & D. Warner (Eds.), *Audio Culture* (pp. 370-380). Continuum.
- Stroppa, M. (1984). The analysis of electronic music. *Contemporary Music Review*, 1 (1), 175-180.
- Thomas, P. (2007). Determining the Indeterminate. *Contemporary Music Review*, 26 (2), 129-140.
- Thompson, P. (2004). Atoms and errors: towards a history and aesthetics of microsound. *Organised Sound*, 9 (9), 207-218.
- Thoresen, L. (2007). Spectromorphological analysis of sound objects; an adaptation of Pierre Schaeffer's typomorphology. *Organised Sound*, 12 (2), 129-141.
- Tormey, A. (2011). *Developing Music Notation for Live Performance of Electronic Music*. Retrieved 2012 6-March from Hexagram.ca: [http://cliec2011.hexagram.ca/Tormey\\_Gestural\\_Notation.pdf](http://cliec2011.hexagram.ca/Tormey_Gestural_Notation.pdf)
- Tremblay, P., & McLaughlin, S. (2009). *Thinking Inside the Box; A New Integrated Approach to Mixed Music Composition and Performance*. Retrieved April 28, 2015, from University of Huddersfield Repository: <http://eprints.hud.ac.uk/4081/>

- Truax, B. (1986). Real Time Granular Synthesis with the DMX 1000. In P. Berg (Ed.), *Proceedings of the International Computer Music Conference*. San Francisco: Computer Music Association.
- Truax, B. (1988). Real Time Granular Synthesis with a Digital Signal Processor. *Computer Music Journal Vol 12 No 2*, 14-26.
- Truax, B. (Composer). (1988). *River Run*. On *Digital SoundScapes* [CD]. WERGO.
- Truax, B. (2000). The aesthetics of computer music: a questionable concept reconsidered. *Organised Sound*, 5 (3), 119-126.
- Truax, B. (2001). *Acoustic Communication*. Westport, CT: Greenwood.
- Truax, B., & Raine-Reusch, R. (Composers). (1995). *Bamboo, Silk and Stone*. [B. Truax, & R. Raine-Reusch, Performers] On *Inside: Computer and Electroacoustic Music by Barry Truax* [CD]. Cambridge Street Records.
- Turner, J. (2001). *The Microsound Scene: An Interview with Kim Cascone*. (A. Kroker, & M. Kroker, Eds.) Retrieved May 11, 2013, from cttheory.net: <http://www.cttheory.net/articles.aspx?id=322%20>
- Vaggione, H. (2001). Some ontological remarks about music composition processes. *Computer Music Journal*, 25 (1), 54-61.
- Vickers, P. (2012, May). *Ways of Listening and Modes of Being: Electroacoustic Auditory Display*. Retrieved January 2, 2015, from Journal of Sonic Studies: <http://journal.sonicstudies.org/vol02/nr01/a04>
- Vincent, M. (2003, December 23). *Michael Vincent*. Retrieved April 9, 2014, from Michael Vincent Writings: <http://michaelvincent.ca/Design/Assets/Writing/contemporary%20violin%20tech.pdf>
- Watts, S. (2013). Bass Clarinet Multiphonics. *PhD Thesis (Keele University)*. unpublished.
- Whittall, A. (2008). *Form*. Retrieved April 25, 2015, from Grove Music Online: [http://www.oxfordmusiconline.com.ezphost.dur.ac.uk/subscriber/article/grove/music/09981?q=form&search=quick&source=omo\\_gmo&pos=1&\\_start=1#firsthit](http://www.oxfordmusiconline.com.ezphost.dur.ac.uk/subscriber/article/grove/music/09981?q=form&search=quick&source=omo_gmo&pos=1&_start=1#firsthit)
- Wilson, S. C., & Collins, N. (2011). *The SuperCollider Book*. Cambridge, Massachusetts: MIT Press.
- Windsor, L. (2000). Through and around the acousmatic: the interpretation of electroacoustic sounds. In S. Emmerson (Ed.), *Music, Electronic Media and Culture*. Ashgate.
- Wishart, T., & Emmerson, S. (1996). *On Sonic Art*. Routledge.
- Wolff, C. (1998). *Cues: writings and conversations*. Cologne.
- Xenakis, I. (1971). *Formalised Music*. Bloomington, Indiana University Press.
- Young, J. (1996). Imagining the Source: The Interplay of Realism and Abstraction in Electroacoustic Music. *Contemporary Music Review*, 15 (1-2), 73-93.
- Young, J. (2004). Sound Morphology and the Articulation of Structure in Electroacoustic Music. *Organised Sound*, 9 (1), 7-14.
- Young, J. (Composer). (2010). X for Piano and Electroacoustic Sounds. On *Shadow Piano* [CD]. Innova Records.
- Zicarelli, D., & Puckette, M. (1990 - 2011). Max. Retrieved 2011 28-July from Cycling 74: [www.cycling74.com](http://www.cycling74.com)

