

Durham E-Theses

The Gift of Creativity: An Approach to a Theology of Technology

DAVID LUNN

How to cite:

LUNN, DAVID (2015) *The Gift of Creativity: An Approach to a Theology of Technology*. Masters thesis, Durham University.

Use policy



This work is licensed under a [Creative Commons Attribution 3.0 \(CC BY\)](https://creativecommons.org/licenses/by/3.0/)

The Gift of Creativity: An Approach to a Theology of Technology

David Lunn

Thesis submitted for the award of the degree of Master of Letters

Department of Theology and Religion

University of Durham

2015

Table of Contents

List of Illustrations	6-7
Acknowledgements and Dedication.....	8
Chapter 1: Creativity, Technology, and Theology.....	9-31
1.1 Ubiquitous Technology	9
1.2 Creativity in Aviation Technology.....	11
1.2.1 Moments of Inspirations	12
1.2.2 Creativity as Delight and Fascination.....	14
1.2.3 Creativity in Production.....	17
1.2.4 Creativity dealing with reality	19
1.2.5 Creativity through Teamwork.....	21
1.2.6 Creativity as innovation.....	22
1.2.7 Creativity as Problem solving.....	24
1.2.8 Building on the work of others	26
1.2.9 Creativity is taken for granted	28
1.3 Summary and moving forward.....	29
Chapter 2: Mapping the relationship between Theology and Technology .	32-57
2.1 Mapping through Philosophy	32
2.2 Mapping using a Theology and Science Model	35
2.3 Mapping using Niebuhr’s ‘Christianity and Culture’ Model	37
2.4 Christ against culture.....	37
2.4.1 George Blair - Technology as alien to Faith.....	37
2.4.2 Jacques Ellul - Technique and Faith in confusion.....	39
2.5 The Christ of culture.....	41
2.5.1 Wilhelm Fudpucker – Technology bringing in the Kingdom of God	42
2.5.2 Charles Coulson – True dignity achieved by Faith and Technology ...	44
2.5.3 Philip Hefner – The Seamless Robe of Evolution, Faith, and Technology	46
2.6 Christ above culture.....	48
2.6.1 Terry Tekippe – Technological confusion needs divine wisdom.....	48
2.7 Christ and culture in paradox	50
2.7.1 André Malet - Technology and Faith living in separate compartments.....	50
2.8 Christ the transformer of culture	52

2.8.1 Egbert Schuurman – Technology in need of sanctified motivation	52
2.9 Conclusions	54
Chapter 3: Creativity	58-85
3.1 Language and Communication.....	59
3.2 Language and Creativity	62
3.3 Creative People are not Unique.....	64
3.4 Creativity is not the Preserve of the ‘Arts’	68
3.5 Progress in Science and Technology.....	71
3.6 Creativity in Science	74
3.7 Imagination.....	78
3.8 Summary	84
Chapter 4: Creation, Creativity, and the Image of God	86-114
4.1 The Place and Use of the Bible	86
4.2 First Creation Narrative in Genesis	91
4.3 Creation of Humankind in the Image of God.....	95
4.4 The Garden of Eden	101
4.5 Beyond Eden	105
4.6 Broadening the Understanding of the Image.....	106
4.7 God, Creation and Christian Theology.....	108
4.8 Summary	114
Chapter 5: Creativity’s Dark Side	115-135
5.1 Process	116
5.2 Product	118
5.3 Person	123
5.4 Press	125
5.4.1 R101 Airship Disaster.....	126
5.4.2 Challenger Space Shuttle Disaster.....	129
5.4.3 The Result of External Pressure	134
5.5 Summary	134

Chapter 6: The City.....	136-159
6.1 Paleolithic beginnings	136
6.2 Neolithic developments.....	140
6.3 Cities and City States	142
6.4 Seeking a scientific theory of Cities.....	144
6.5 Cities and God.....	148
6.5.1 Revelation’s Surprise.....	148
6.5.2 The beginning of Cities in the Bible.....	150
6.5.3 Urbanisation and Judgement.....	155
6.6 Conclusion.....	158
 Chapter 7: Divine and Human Creativity.....	 160-186
7.1 To be human is to be creative.....	160
7.2 Technology is the modern human environment.....	165
7.3 The Christian roots of modern Technology	166
7.4 The Reformation and Technology.....	169
7.5 The Development of this-worldly Goals	171
7.6 Technological Systems.....	173
7.7 Creativity and monolithic Technology.....	174
7.8 The Domination of Nature	176
7.9 God and Violence in Creation.....	177
7.10 Does God enjoy Violence?.....	179
7.11 God’s apparent ambiguity towards Creation.....	182
7.12 The Image of God as a paradigm to direct Technology ...	184
 Chapter 8: The Purposes of God.....	 187-209
8.1 Human Beings are not the ultimate goal of God’s creativity.	188
8.2 Space for creativity.....	190
8.3 God’s risk in creation	193
8.4 God’s New Creation.....	196
8.4.1 God’s decisive action.....	196
8.4.2 The Historical Bodily Resurrection of Jesus	198
8.4.3 The Resurrection to come in God’s New Creation.....	199
8.4.4 Preparing for New Creation.....	201
8.5 New Creation validates human action in the present	203

8.6 Technology led by Love, Humility, and Caution	204
8.7 God’s new creation as a place of creativity.....	205
8.8 Aeronautical Creativity yielding Service and Worship.....	207
 Chapter 9: Conclusion.....	 210-213
9.1 Creativity at the Heart of Technology	210
9.2 Creativity not found in Theologies of Technology	210
9.3 Creativity at the Heart of being Human	211
9.4 Human Creativity is a Reflection of God’s Creativity	211
9.5 The Dark Side is not fundamental to Creativity	211
9.6 Creativity, the City and God.....	212
9.7 Divine and Human Creativity.....	212
9.8 The Purposes of God	212
9.9 In Summary	213
 Appendix: Illustrations relating to Creativity in Aviation in Chapter 1.....	 214-220
 Bibliography	 221-233

List of Illustrations

Fig.1.1	Examples of Modern ‘Tube and Wing’ Airliners.....	214
Fig.1.2	Variations on ‘Tube and Wing’ Design.....	215
Fig.1.3	First Flight with Orville at the controls	215
Fig.1.4	George Cayley’s 1853 sketch of the 1849 child-carrying craft.....	215
Fig.1.5	Comparison of Camm’s 1927 patent joints with Hurricane fuselage joints ..	216
Fig.1.6	Burt Rutan’s prototype Variviggen	216
Fig.1.7	The Virgin Galactic vehicle and launcher	216
Fig.1.8	Rutan’s Beech Starship.....	216
Fig.1.9	Photograph and plan view of the Rutan Boomerang.....	217
Fig.1.10	Diagram of riveted and glued skin panel.....	217
Fig.1.11	Examples of a wing rib and wing skin milled from solid aluminium alloy.....	217
Fig.1.12	All-carbonfibre reinforced plastic fin box of Airbus A310.....	218
Fig.1.13	The Silent Aircraft Initiative SAX-40	218
Fig.1.14	Northrop’s Flying Wings, the YB-49 Experimental Bomber and the B-2 Stealth Bomber	218
Fig.1.15	X-48C Blended Wing Body Test Model Aircraft	219
Fig.1.16	Extreme options from brain-storming sessions	219
Fig.1.17	Weighting table used to evaluate options	219
Fig.1.18	Interim silent aircraft design proposal	220
Fig.1.19	Cranfield’s ‘Greenliner’ design proposal	220
Fig.3.1	Student Technical Drawing Exercise	61
Fig.3.2	Some representations of ethane	62
Fig.5.1	General Arrangement of a Space Shuttle at Launch.....	130
Fig.5.2	Make-up of a Solid Rocket Booster	131
Fig.6.1	Bettencourt and West’s Data on Cities.....	145

Fig.8.1 Red Arrows ‘Heart’ Manoeuvre208
Fig.8.2 Christen Eagles at the EAA Museum, Oshkosh, Wisconsin
– ‘like a prayer’209

Copyright notice

The copyright of this thesis rests with the author. No quotation from it should be published without the author’s prior written consent and information derived from it should be acknowledged.

Acknowledgements

I should like to thank my old friend Professor Douglas Davies for his help in getting me underway with this thesis under the supervision of Professors, as they became in the course of completing it, David Wilkinson and Robert Song. My thanks go to them for their advice, direction, and support especially when external factors intruded to delay progress. I should also like to thank another old friend, Professor John Fielding of Cranfield University for directing me towards the modern aeronautical research related to chapter 1.

Most of all it is to Mary, my longsuffering wife, that my thanks go for her love in supporting me through this exercise.

Dedication

I dedicate this work to the memory of a dear friend and brother in Christ, Michael Sanderson. Formerly Professor of Mechanical Engineering at Cranfield University he was a truly creative engineer but passed from this life before we could discuss the conclusion of this work.

Chapter 1

Creativity, Technology, and Theology

1.1 Ubiquitous Technology

The young citizens stream out of the self-destructing city which, by its unintended background technology, had given them birth, nurtured them, provided their playground, and which would have ended those lives at the age of thirty. As they emerge they are captivated by a vision of old age played by Peter Ustinov. So the 1976 film 'Logan's Run' comes to its happy ending. But they are all going to die for this hidden, taken for granted technology, on which they had unconsciously relied, has left them ill equipped to live in the wilderness in which they find themselves. The film provides an unintended commentary on our modern, western, but increasingly global, technologically based society where 'if technology suffered a setback, millions of people would perish'.¹ It was in 1939 when José Ortega y Gasset, ignorant of jet airliners, computers, mobile phones, and all the rest of the intertwining technology that has developed since that time, wrote those words.

Technology, however, is not totally hidden and there are aspects of it that raise concerns amongst people. These worries involve not only nuclear weapons, government computer databases, and embryo research but also the indirect and unintended effect that technology has on our lifestyles. E.M.Forster's short story from 1909, 'The Machine Stops', depicts a society where people live in isolation and only communicate through The Machine. That is fiction, but Michael Chorost's autobiographical account of becoming a cyborg by having a computer controlled cochlear implant to overcome his profound deafness includes a telling story from his grandparents. The arrival in America of air-conditioning and television resulted in the people of their community retreating into their now comfortable homes to be entertained of an evening instead of being out and about meeting their neighbours and so gradually they 'were beginning to forget each other's name.'² There is a fear that technology will cause us to adapt to it and we become enslaved by it. This fear can be seen in the depiction of the Borg in 'Star Trek – the Next

¹ José Ortega y Gasset, 'Thoughts on Technology,' in Carl Mitcham and Robert Mackay (eds.), *Philosophy and Technology*. (New York: Free Press, 1983; reprint, 1st Paperback), 311.

² Michael Chorost, *Rebuilt. How Becoming Part Computer Made Me More Human* (London: Souvenir Press, 2006), 128.

Generation' and especially in Jean-Luc Picard's reaction to having been adapted, against his will, into the colony where the hardest thing, he confessed, was his helplessness.

Technology can also change our thinking in subtle ways and the products of our technology can become the means by which we understand ourselves. Willem Drees, reflecting upon expressions such as being 'under stress' or needing 'to let off steam', comments, 'we may consider ourselves as made in God's image, but we speak of ourselves as if we are in the image of machines.'³ Our brain is likened to a computer in Jim Horne's newspaper article on sleep and dreams in which he suggests 'we should view REM sleep not as true sleep but as a type of wakefulness, or even non-wakefulness, rather like screen-saver mode on a computer.'⁴ In 1971 Marc Bolan and T-Rex had a hit record 'Get it on' in which the singer serenades his girlfriend with the words:

'You're built like a car
You got a hubcap diamond star halo
You're built like a car
Oh yeah'⁵

Technology is then ubiquitous in our culture, but our relationship to it is ambivalent, welcoming new gadgets and possibilities on the one hand but being fearful of where it is going when we recognise its presence at all. In this context it is surprising that 'technology as such has rarely been thematized as a matter of theological reflection'⁶ and 'very few theologians have enunciated a well-defined position regarding technology in general.'⁷ In this thesis I shall engage in such a reflection and argue that technology is a gift from God to humanity through which we are invited corporately to share imaginatively in God's creative activity in the world in a manner appropriate to the nature and purposes of God.

³ Willem B. Drees, 'Introduction: Technological and Moral Creatures or Creators?', in Ulf Gorman, Willem B. Drees, and Hubert Meisinger (eds.), *Creative Creatures*. (London: T&T Clark, 2005), 4.

⁴ Jim Horne, 'To Sleep, Perchance to Think,' *Daily Telegraph*, May 2nd 2006.

⁵ Marc Bolan, *T.Rex Lyrics - Get It On* ([cited 24th June 2014]); available from <http://www.azlyrics.com/lyrics/trex/getiton.html>.

⁶ George Pattison, *Thinking About God in an Age of Technology* (Oxford: Oxford University Press, 2005), 1.

⁷ Dennis William Cheek, 'Theology & Technology: An Exploration of Their Relationship with Special Reference to the Work of Albert Borgmann and Intelligent Transportation Systems' (PhD, Durham, 2006), 73.

1.2 Creativity in Aviation Technology

My starting point is not, however, a general survey of technology in society. Rather it is my specific experience of the aircraft industry in which I began my working life as an engineer before becoming an ordained minister in the Church of England. Reflecting on these two strands to my life I have become aware of the lack of interaction of Christian theology with technology which as I see as a fundamentally creative human activity in the world. The purpose of this thesis is to bring together these different strands of my experience, those of being an engineer and a theologian. I am not, however, doing this simply for personal satisfaction. This thesis also provides a key test case for the relationship between theology and technology for two reasons.

The first is that because there is public interest in and concern about technology any theological interaction has to be understandable by that public which may be baffled by the prospect of such an interaction. Certainly the responses I have received when speaking of this piece of research have included puzzlement from people who are not antagonistic to religion and theology but in whose minds these do not overlap with technology. On the other hand some people, including engineers, have been of the opinion that such work is necessary and overdue. The second reason is that theology will have to demonstrate that it has the resources to deal with communal as well as individual creativity because both, as will be shown, are to be found in technology. By way of introduction this chapter will present a number of different ways in which human creativity is active in the aviation industry.

Creativity based on imagination, that picturing of ‘the non-existent into existence,’⁸ has been and continues to be a fundamental aspect of aviation technology. This may not seem obvious to people passing through an international airport who, if they thought about it at all, might well consider that there is little creativity at work in aircraft design apart from the artwork applied to modern passenger jet aircraft. So many commercial airliners have the same basic ‘tube and wing’ layout of a cylindrical fuselage set on top of a pair of swept-back wings which carry podded engines slung underneath. The basic layout at the tail of a vertical fin with rudder and the tail planes carrying the elevators is also the same. Fig.1.1 (p.214) shows a number of examples of this layout. The latest

⁸ Philip Hefner, *Technology and Human Becoming* (Minneapolis: Fortress Press, 2003), 45.

offerings from Boeing, the 787, and Airbus, the A350, follow the same pattern. There are variations in the basic design layout that can be seen but even these are mainly tried and tested formulae now such as those in Fig.1.2 (p.215) which include mounting the main wing over the fuselage and setting the engines at the rear of the fuselage.

This apparent lack of innovation hides the creativity that is part of aviation technology. There has been a great deal of historical creativity, modern creativity is hidden by the paintwork, and there is on-going creativity as the industry looks to meeting the demands as well as the opportunities of the future. In order to demonstrate creativity being manifested in this field a variety of themes will be explored. The first theme is creative inspiration.

1.2.1 Moments of Inspirations

Inspiration often comes when the mind is focussed away from a problem. A famous example of this is Kekulé's experience of solving problems in organic chemistry whilst he was dozing and his conscious mind was not engaged with the problems.⁹ In one way such inspiration is unremarkable. Polanyi has explored the tacit knowledge and skills that, residing in the subconscious mind, undergird all human knowledge, including what we regard as objective scientific knowledge.¹⁰ When Kekulé was dozing his subconscious mind had the freedom to find connections within the material available to it which his conscious mind would never have considered. Whether the creative ideas produced in this way are of value have to be assessed using personal judgement based on what are 'for the most part only tacit understandings.'¹¹ The Wright Brothers experienced such inspirations as they progressed towards December 17th 1903 when Orville Wright took the powered flying machine that he and his brother, Wilbur, had developed for its first flight of twelve seconds at Kitty Hawk, North Carolina (Fig.1.3 p.215) thus ushering in the age of the aeroplane.

The brothers' interest in flight had first been sparked when their father had brought home a rubber band powered helicopter toy. Wilbur's efforts to build larger versions were not

⁹ Alexander Findlay and Trevor I. Williams, *A Hundred Years of Chemistry*, 3rd revised ed. (London: Duckworth, 1965), 38f.

¹⁰ Michael Polanyi, *Personal Knowledge*, 1st paperback ed. (London: Routledge & Kegan Paul, 1973), 3-245.

¹¹ Michael Polanyi and Harry Prosch, *Meaning* (Chicago: Chicago University Press, 1977), 186.

successful so their interest waned until they read of Otto Lilienthal's accidental death whilst attempting a glide off a hill. They reasoned that if birds could glide 'without the use of any muscular effort'¹² then so could a human being. They also realised that the problem was not just about getting airborne but also about how to control the aircraft in order to remain airborne. The brothers had observed the way 'birds twist their wings tips, changing the angle of the leading edge presented to the wind'¹³ in order to control gliding and soaring flight but their initial idea for achieving this variation in the wings of a glider was impractical. One day whilst selling a bicycle wheel inner tube Wilbur idly twisted the long box at the ends whilst talking with a customer. It dawned on him at this point that what they needed to do was to arrange to twist the wings of their aeroplane at the tips and so 'wing-warping' was invented and successfully tried out on a model glider. This was undoubtedly a creative leap for Wilbur transferring an observation in one area of life into an idea for achieving an aim in a different area.

Orville also had a creative moment faced with a different problem of control. They had installed twin vertical fixed fins at the rear of their glider to give stability around the vertical axis but they found it could make matters worse. The then novel idea of using a moveable rudder came to Orville one night¹⁴ and Wilbur, accepting the idea, developed it by suggesting linking the controls to those of the wing-warping. It can be seen that the brothers had creative flashes of inspiration in solving the problem of how human beings can fly. The fact that there were the two of them may have aided their success as they will have been 'well used to bouncing ideas off each other.'¹⁵

Another aircraft designer who got some inspiration at night was Barnes Wallis. He started his career in aviation designing airships for Vickers and became the Chief Designer of the R100 built in competition with the R101. His creative capacity is demonstrated in that more than twenty patents were registered under his name under the general heading of 'Improvements in or relating to Airships' in the early days of work on the R100. This came about as Wallis, who had never shown any exceptional qualities at

¹² Orville Wright, 'How We Invented the Airplane,' in Fred C. Kelly (ed.), *How We Invented the Airplane*. (New York: Dover Publications, 1988), 11.

¹³ Rosamund Young and Catharine Fitzgerald, *Twelve Seconds to the Moon* (Dayton, Ohio: United States Air Force Museum Foundation, 1983), 18.

¹⁴ *Ibid.*, 45.

¹⁵ David Lunn, '100 Years of Sustained Powered Flight,' *Borderlands/St John's College, Durham*, no. 3 (2004): 40.

school, ‘discovered in himself a genius for finding novel answers to questions which had exercised the minds of airship engineers since Zeppelin’s first endeavours early in the century.’¹⁶ A major problem in designing airships of increasing size is that it is not possible to scale up all the components as they become too large and heavy to manufacture and handle. New designs were needed. Wallis was aware of this problem from the beginning and early on he told his wife-to-be ‘that he had woken up in the morning with the ghost of a new idea lingering in his brain.’¹⁷ This creative spark was the beginning of his finding a solution to this problem and the development of the solution led to the idea of geodetic construction which culminated in the design of the Wellington bomber, the robust mainstay of British Bomber Command in the early years of World War two.

This nocturnal inspiration appears to have been a one-off experience for Wallis who clearly employed visual thinking and imagination and who ‘saw himself as a creator, an original solving all problems ‘on my own drawing-board’.’¹⁸ Wallis’ experience came as a consequence of his employment but his real delight was in boats. The Wright brothers ran a cycle shop as their employment and aviation was more of a hobby resulting from their fascination with the subject and this leads to the next theme where curiosity and imagination rather than any financial gain are the main stimuli to creativity in technology.

1.2.2 Creativity as Delight and Fascination

The Wright brothers ran a successful business of designing, building, selling and repairing bicycles¹⁹ which provided the finance and engineering experience needed to pursue their all-consuming passion for flying. It enabled them to embark on a period of research, design, development, and testing starting with model gliders, and concluding with a motorised aeroplane capable of prolonged flight. It was the Wright brothers who first achieved powered, sustained and controlled flight and who thus ‘invented the airplane’²⁰ but it was only when they reached this point that they attempted to convert

¹⁶ J. E. Morpurgo, *Barnes Wallis* (London: Penguin, 1973), 162.

¹⁷ *Ibid.*, 145.

¹⁸ *Ibid.*, 176.

¹⁹ Fred C. Fisk and Marlin W. Todd, *The Wright Brothers from Bicycle to Biplane* (Ohio: Fred C. Fisk & Marlin W. Todd, 2003), 24-40.

²⁰ Richard P. Hallion, *Taking Flight* (New York: Oxford University Press, 2003), xvii.

their hobby into a money making scheme. Their creative contribution to aviation appears to have ceased at this point and they did not develop their aeroplane beyond increasing reliability and range and carrying a passenger with the same basic layout.

Another major pioneer in the field of aviation was Sir George Cayley (1773-1857), a landowning country gentleman in Yorkshire whose main preoccupation was that of managing his estates and tenants as well as his family. Amongst his many achievements he invented the 'caloric engine', an external combustion hot-air engine which he saw as a step towards the internal combustion engine, and he also devised a gunpowder engine.²¹ This work was, at least in part, motivated by his realisation that sustained human powered flight was unfeasible and what was needed was a lightweight engine, the steam engines of his day being impractical for the purpose.

His creative originality in aviation can be seen in that, 'unlike all his predecessors and even some of those who succeeded him'²², he distinguished between the issues surrounding how a plane may be supported in the air by its wings and those concerned with moving the plane with an engine. He conceptualised the configuration of the modern aeroplane with its fuselage, crew cockpit, fixed wing, and cruciform tail surfaces. He also devised a lightweight adjustable tension wheel, the forerunner of the bicycle wheel, to serve as the undercarriage of an aircraft.

Cayley carried out theoretical study combined with practical experimentation such as using a whirling arm device to measure lift and drag of flat plates and cambered surfaces. He considered the issue of streamlining, measuring the shape of a trout, and recognised the significance of giving dihedral to a pair of wings, i.e. angling them up from the centre to the tips, for increased stability in flight. Cayley not only flew a successful model aeroplane glider in 1804 but also two gliders, the second of which was a triplane, both of which carried a child in 1809 and 1849 (Fig.1.4 p.215). In 1853 he capped all these by flying his coachman in a glider across a small valley. Cayley's glider designs were put to the test in the early 1970s when full size replicas were built and successfully flown.²³

²¹ Charles H. Gibbs-Smith, *Sir George Cayley's Aeronautics* (London: Her Majesty's Stationery Office, 1962), 23ff.

²² Hallion, *Taking Flight*, 108.

²³ Leonard Rivett and Jim Matthew, 'A Yorkshire Genius,' (Elvington, York: Yorkshire Air Museum, 1996), 25f.

Cayley published a series of three papers entitled “On Aerial Navigation” in Nicholson’s *Journal of Natural Philosophy* 1809/10.²⁴ If the information given in them had been properly absorbed by those who followed him then ‘most of the torrent of designs and suggestions which was poured out by European and American inventors over the next hundred years would have been saved.’²⁵ It is because of his creative contribution to aeronautics, made as he pursued his hobby, that George Cayley has been generally acknowledged as ‘the Father of Aerial Navigation’ and indeed ‘the father of aeronautics.’²⁶

In contrast to the Wright Brothers and George Cayley, Burt Rutan has found his employment in the established aviation industry and this has been his way of pursuing his passion. In 1972 the prototype of his VariViggen (Fig.1.6 p.216) flew for the first time. This was a novel design, intended for home-building and consisted of a two seat delta winged canard design with a single pusher propeller named in honour of the Viggen, a Swedish jet fighter of that period. This was followed by his original ideas for incorporating glass fibre composite materials in home-build light aircraft such as his VariEze design, variants of which have been built by amateurs in large numbers all over the world.

Perhaps the best example of Rutan’s creativity is the Boomerang aeroplane. This is a small twin engine aircraft the plan view of which (Fig.1.9 p.217) reveals it to be totally asymmetric, with the engines being each of a different power, yet it flies perfectly. The design is so unusual that Rutan himself tells of how he was once asked, ‘what in the hell were you smokin’ when you laid that one out?’²⁷ This craft was never intended for production either by home-builders or a commercial enterprise and was designed, built, and continues to be flown simply for the pleasure of it. However if an aircraft is to be put into production then it is not just its final shape that is a matter for creative design but also the way it is to be built.

²⁴ Reproduced in Gibbs-Smith, *Sir George Cayley's Aeronautics*, 213 - 37.

²⁵ *Ibid.*, 45.

²⁶ Hallion, *Taking Flight*, 105.

²⁷ Bert Rutan, *Step-by-Step Comparison* (Rutanboomerang, [cited 25th July 2013]); available from www.rutanboomerang.com/index.php/design/design-explanation.

1.2.3 Creativity in Production

Production engineering has developed alongside the advances made in aerodynamics and structures. Sydney Camm designed the Hawker Hurricane 2nd World War fighter aircraft and went on to be involved with the design of other successful aircraft until well after the Second World War including the Hunter jet fighter and the vertical take-off and landing Harrier. However his creativity can also be seen in his proposal to standardise the components and assembly methods of the basic framework of an aircraft fuselage. When he joined the Hawker aircraft company in 1923 an aircraft would be made of a basic wood or metal framework covered in wood and fabric to give the final shape. Hawker's managing director, Fred Sigrist, was a master welder so a welded steel tube framework was tried out for the unsuccessful Hornbill fighter. Camm then proposed a simpler form of tubular metal structure with endplate joints bolted together to make up the framework. His vision was to see that if this standardisation was achieved then the design, construction and repair of aircraft would be simplified. A patent was granted in 1927 for "improvements in or relating to Skeleton Structures such as aircraft fuselages" and this method 'was the basis of all fuselage designs at Kingston until the late 1930s'²⁸ including the Hurricane. (Fig.1.5 p.216)

Fred Sigrist acknowledged that these structures were simpler and cheaper to make and repair compared to welded ones and 'thereafter his oft-quoted words were famous, "Find me a chippy with a spanner and we'll mend the aeroplane."' ²⁹ Camm's creative thinking about the process of building an aircraft highlights an area of engineering where imagination is as vital as in any other area of industry as technology develops. This is especially true as new construction materials become available.

Since the 1940's the principal material used in aircraft has been aluminium because of its superior weight and strength properties. In its pure form aluminium is of 'little use to man or beast as a structural material'³⁰ but when it is alloyed with small proportions of other elements its usefulness is greatly enhanced and special alloys have been developed over the years to suit different requirements. Not only that but also a range of techniques

²⁸ Robert L. Lickley, 'The Life and Work of Sir Sydney,' in John W. Fozard (ed.), *Sydney Camm and the Hurricane*. (Shrewsbury: Airlife Publishing, 1991), 58.

²⁹ Francis K. Mason, *The Hawker Hurricane* (Manchester: Crécy Publishing, 2001), 14.

³⁰ Darrol Stinton, 'The Structural Revolution,' in Philip Jarrett (ed.), *Biplane to Monoplane, Putnam's History of Aircraft*. (London: Putnam, 1997), 136.

and machines have been created in order to form the basic material into a range of shapes that can be assembled to form the aircraft structure.³¹ Assembly was often by gluing or riveting the different components together as in fig.1.10 (p.217). The Comet airliner, designed by de Havilland, involved much use of redux bonding (gluing). Avro, as a company, favoured the use of rivets, mechanical fasteners, in the production of their aircraft one of which, the Shackleton, was affectionately known as “40,000 rivets flying in more or less close formation.”³²

However new ways of using aluminium have been developed. The devising of numerically controlled machines enabled the repeated and accurate milling of complex shapes from solid blocks of aluminium without a human operator controlling the milling head. ‘Given the historical link between weaving and computing,’³³ the roots of this innovation can be traced back to Jacquard’s loom of 1804. The first machines were programmed using punched tape but now they are controlled by computers. For aircraft these machines have been used for producing larger components, such as wing ribs and skins (see Fig.1.11 p.217) from solid billets of aluminium alloy resulting in a reduction in the number of component parts and an increase in the integrity of the structure. This has led to cost reductions in various ways and also to a significant reduction in the number of stress raisers such as joints and holes thereby increasing resistance to fatigue.³⁴ This innovation in production yielded improvements in both design and production.

The use of aluminium has been superseded by that of carbon-fibre in some structural areas. An early example is the development of the aluminium-winged Harrier G.R. Mark 3 of 1975 into the G.R. Mark 5 of 1985 which had a single-piece carbon-fibre wing.³⁵ Development in military aircraft was followed by increasing incorporation of carbon-fibre into airliners. Carbon-fibre is a filament of carbon which is very strong along its length but to become a useful material the filaments, aligned in the same direction, are usually encased in plastic. This results in a material that is strong and rigid in the

³¹ John Cutler and Jeremy Liber, *Understanding Aircraft Structures*, 4th ed. (Oxford: Blackwell, 2005), 112-23.

³² D. Clark, *211 Squadron Raf* (D Clark & others, 2001 [cited 23rd August 2013]); available from http://www.211squadron.org/w_baird.html.

³³ James Essinger, *Jacquard's Web* (Oxford: Oxford University Press, 2004), 256.

³⁴ Ray Whitford, 'Structures and Materials,' in Philip Jarrett (ed.), *Modern Air Transport, Putnam's History of Aircraft*. (London: Putnam, 2000), 76f.

³⁵ Francis K. Mason, *Hawker Aircraft since 1920* (London: Putnam, 1991), 435, 59.

direction of the fibres but very weak and pliable at right angles to this direction. This problem is overcome by building up layers, before the plastic is set, in different directions. Designers can now tailor the material to suit the particular stress requirements of different parts of the aircraft. Over the years the use of carbon-fibre composites has increased. The structure of the 1994 Boeing 777 comprised 16% carbon fibre composites.³⁶ This rises to 50% in the Boeing 787 'Dreamliner' which entered service in 2012. The whole fuselage of this aircraft is constructed from carbon fibre composite materials rather than aluminium alloys. To do this on a production line a great deal of creativity had to be used to design and build the specialised machinery³⁷ which is needed to ensure the consistency and reliability of the finished product.

1.2.4 Creativity dealing with reality

It is not just nature that 'cannot be fooled'³⁸ when designing modern aircraft for reality encompasses much more for the designer. Consistency and reliability are required in modern airliners not least because of the regulatory bodies that governments have set up to ensure that standards of safety and pollution control are met. This is one of the ways in which reality impinges upon and stimulates creativity in this industry as there can be conflicting requirements with which designers have to grapple.

A recent example of this is a project undertaken at Cranfield University to design an airliner which uses less fuel and makes less noise than current types. One solution that the staff and students came up with was the 'Greenliner' (Fig.1:19 p.220) which was able to reduce airport noise levels and fuel burn but with the penalty that it would fly 10% slower than current airliners.³⁹ In the design process there is often a compromise to be found between conflicting requirements. Finding a compromise that works is itself a creative enterprise.

³⁶ Whitford, 'Structures and Materials,' 78.

³⁷ *One-Piece Barrel*, (Boeing, [cited 23rd August 2013]); available from http://www.newairplane.com/787/design_highlights/#/visionary-design/composites/one-piece-barrel.

³⁸ Richard P. Feynman, 'Richard P. Feynman's Minority Report to the Space Shuttle Challenger Inquiry,' in Jeffrey Robbins (ed.), *The Pleasure of Finding Things Out*. (London: Penguin Books, 2001), 169.

³⁹ Sunil Mistry, H. Smith, and John P. Fielding, 'Novel Design Concepts for Aircraft with Reduced Noise and Global Warming Characteristics,' in *26th International Congress of the Aeronautical Sciences* (Anchorage, USA: 2008), 3f.

In designing the Spitfire fighter R.J. Mitchell, ‘a poet among engineers, a strange combination of soaring vision and down-to-earth practicality,’⁴⁰ had to bring his creative powers to bear on a different aspect of reality, that of the operational military requirements for fighter aircraft including the need for wheels and guns. Mitchell’s design used stressed skin technology with which he had become familiar through the successful development of the Schneider Trophy series of seaplane racers. In this design the aircraft skin is reinforced with frames and stringers so that it becomes the load-bearing framework itself (see Fig.1.10 p.217). This form of construction allowed Mitchell to propose a thin elliptical wing for the Spitfire contrary to the then current trend in aerodynamic thinking which favoured the ‘thick wing high-lift philosophy’⁴¹ found in other parts of the Vickers/Supermarine organisation. Great ingenuity was displayed by Mitchell and his design team in the incorporation of an eight machine gun battery and a retracting undercarriage into this thin wing.

Reality not only includes nature and design specifications but also customer reaction and the economic and political situation. In the former category is a Burt Rutan design for the Beech Company, the ‘Starship’ (Fig.1.8 p.216). This is a striking and technically successful design, i.e. it works, which drew on the Rutan’s Varietee shape. However it proved to be ‘almost too innovative for its market, and Beech only built fifty-three between 1986 and 1994.’⁴² The corporate executives at whom it was aimed did not feel comfortable with its advanced innovative design.

Barnes Wallis came up against a different aspect of reality. His creative genius was evidenced in the 2nd World War through the ‘bouncing bomb,’ used in the famous Dambusters Raid, and in the ‘Tallboy’ and ‘Grand Slam’ earthquake bombs⁴³ as well as the geodetic design of the Wellington bomber. Beyond those weapons of war he saw the possibility of supersonic passenger flight using the newly invented the jet engine. He realised the problems that such aircraft, being shaped for high-speed flight, had when it came to the need for low-speed take-off and landing. He devised variable-geometry,

⁴⁰ Morpurgo, *Barnes Wallis*, 197.

⁴¹ C. F. Andrews and E. B. Morgan, *Supermarine Aircraft since 1914* (London: Putnam, 1981), 209.

⁴² Sue Bushell, ‘Business Aviation,’ in Philip Jarrett (ed.), *Modern Air Transport, Putnam’s History of Aircraft*. (London: Putnam, 2000), 239f.

⁴³ John B. Rabbets, *Barnes Wallis* (Yorkshire Air Museum, Elvington, York: Barnes Wallis Memorial Trust).

swing-wing aircraft and demonstrated them in model form as the 'Wild Goose' and 'Swallow'⁴⁴ but to no avail. Creativity and practicability are not enough in the area of this kind of technology. Many political and financial factors come into play as they did to close off the prospects for these creative ideas.

1.2.5 Creativity through Teamwork

Genius in creativity is often regarded as an individual trait and it is easy to focus on the work of individuals such as are mentioned in this chapter. However the reality is that in technology it is usually through involvement of teams of people with different skills that creative ideas come to fulfilment. Barnes Wallis was not working alone when all his airship patents were granted. As a passionate advocate of the use of light aluminium alloys in the structure of aircraft he had an eminent metallurgist, Maj P.L. Teed, in his team.⁴⁵ Aluminium alloys have now dominated the aviation industry for many years⁴⁶ but in the early days Wallis had need of an expert in that material in order to use it effectively in his designs.

In the same way R.J. Mitchell and his design team relied on the work of Beverley Shenstone, an aerodynamicist, in the design of the Spitfire's elliptical wing.⁴⁷ Even wider co-operative creativity was involved with the design of this aircraft because there had to be a constant liaison with the Roll-Royce designers of the Merlin engine who not only kept the performance of their engine ahead of those of the German aircraft but managed to do it without requiring any material change in the size of the airframe itself. This creative collaboration continued throughout the development of the aircraft, even after Mitchell had died from cancer, as the power plant increased in size and power.⁴⁸

Burt Rutan formed a company called Scaled Composites which does creative design and prototyping work for other people and organisations. Examples of its work include the 'Virgin Galactic' spaceship and the Beech 'Starship' (Figs.1.7 & 1.8 p.216). Rutan attributes his success to his belief in the creative power of 'small, closely-knit project

⁴⁴ C. F. Andrews and E. B. Morgan, *Vickers Aircraft since 1908*, 2nd ed. (London: Putnam, 1988), 564.

⁴⁵ *Ibid.*, 30.

⁴⁶ William Alexander and Arthur Street, *Metals in the Service of Man*, 9th ed. (London: Penguin, 1989), 153-68.

⁴⁷ Andrews and Morgan, *Supermarine Aircraft since 1914*, 210.

⁴⁸ *Ibid.*, 209-14.

teams and an environment unlimited by aversion to risk.’⁴⁹ As he says, ‘Our best performances come from structuring a specific blend of creative talent with others whose passion is to apply an innovative breakthrough to the building and testing of a real product’⁵⁰

This belief in the value of small design teams resonates with that of Sidney Camm in an earlier generation.⁵¹ It also fits in with Hanson’s view that a team should have just one really creative person in it with the rest of the team acting as a support group. This group should ‘include high-caliber engineers and designers, but these technical support people need not be highly creative themselves.’⁵²

1.2.6 Creativity as innovation

Aircraft design in the field of civil aviation tends to be a conservative endeavour, i.e. tried and tested methods and designs are favoured, but one in which there is a constant seeking for improvements. These improvements tend to be of a modest incremental nature because they are a source of risk especially to the manufacturing company as ‘too great an improvement may not be achievable and too little may be too small to be attractive’⁵³ to a customer airline. Creativity is often seen in gradual innovation and it is only over a more prolonged period of time that greater changes can be seen to have happened. This is certainly true of carbon-fibre as a structural material.

In the late 1960s and early 1970s I was involved with this material in the early days of its development. The Airbus A310-300 was, in 1985, the first airliner to use carbon fibre reinforced plastic for a large primary structural component, the fin box (see Fig.1:12 p.218) and 8% of its overall structural weight was this new material. It had taken over fifteen years for a significant, yet still modest, change to be made. The material has been adopted slowly because of the need to sure its behaviour is understood and predictable as well as the need to create appropriate design, manufacturing, and inspection methods.

⁴⁹ Scaled-Composites, *About Us* ([cited July 25th 2013]); available from www.scaled.com/about.

⁵⁰ Scaled-Composites, *Burt Rutan* ([cited 25th July 2013]); available from www.scaled.com/about/burt-rutan.

⁵¹ Lickley, 'The Life and Work of Sir Sydney,' 60.

⁵² Thomas F. Hanson, *Engineering Creativity*, 2nd ed. (Newhall, CA: T. F. Hanson, 1987; reprint, 1997), 42.

⁵³ John P. Fielding, *Introduction to Aircraft Design*, ed. Michael J. Rycroft and Robert F. Stengel, *Cambridge Aerospace Series* (Cambridge: Cambridge University Press, 1999), 11.

Boeing's work has been referred to above and Airbus has continued doing similar research and development work.

Airbus claims for its A350 aircraft that 'the 53 per cent of composites utilised in the fuselage and wing reduces the need for fatigue-related inspections' and that using these composites and titanium also reduces the aircraft's 'overall fatigue and corrosion maintenance tasks by 60 per cent.'⁵⁴ This shows how the goals of reducing the weight of the aircraft, for fuel economy reasons, and of reducing the cost of future maintenance have been drivers of the creativity used in designing this aircraft. It has taken over forty years of development to reach this point.

Another innovation in this aircraft has been driven by the need to reduce aircraft noise during the take-off and landing phases of a flight. The flaps have been designed to move to such positions as will least interfere with the airflow around the wing whilst still providing the extra lift needed. This is part of a broader innovation which has an on-board computer system adjusting the moveable wing surfaces so that 'the wing will be "morphed" while airborne – tailoring it for maximum aerodynamic efficiency in the various phases of flight.'⁵⁵

Many innovations that have been hidden by the paintwork have taken shape without the travelling public being aware of them. In this way the creativity used by the designers has also been obscured as they have sought ways of reducing the costs of operating the airliners. The main target has been to reduce the amount of fuel used, not just as a matter of economy but also to reduce carbon dioxide emissions into the atmosphere. However there is increasing concern over noise, as mentioned above, leading regulators to insist that airliners become quieter. As engine noise has reduced, with the introduction of turbofan engines with increasing bypass ratios, so the awareness of aerodynamic noise produced by the airframe itself has increased. This noise occurs especially when the undercarriage and wing flaps are deployed during take-off and landing. The Airbus A350 mentioned above uses special techniques with the wing flaps in order to reduce this

⁵⁴ *A350 Xwb Technology*, (Airbus, [cited 23rd August 2013]); available from <http://www.airbus.com/aircraftfamilies/passengeraircraft/a350xwbfamily/technology-and-innovation/>.

⁵⁵ *Designed with the Future in Mind*, (Airbus, [cited 23rd August 2013]); available from <http://www.a350xwb.com/intelligent/design/>.

noise.⁵⁶ However it is unlikely that the incremental improvement processes used in developing airliners of the conventional tube and wing variety will be able to meet noise standards required in the future. To quote Professor Jeremy Astley, ‘We have reached the point of no return without redesigning the airframes.’⁵⁷ At the same time the experience and confidence gained in the use of carbon fibre referred to above also yields the advantage of allowing designers ‘much more freedom when trying to juggle the conflicting demands of aerodynamic efficiency, fuel savings and reducing engine noise.’⁵⁸

1.2.7 Creativity as Problem solving

The noise generated by airliners is a growing problem around airports worldwide as the number of flights has increased. Despite recent success in reducing airliner engine noise at the same time as increasing fuel efficiency it is clear that a point has been reached where further reductions are possible but at the cost of increased fuel consumption.⁵⁹ The focus has had to shift from the engines to the design of the whole airframe including the incorporated engines. An example is the ‘Greenliner’ (Fig. 1.19 p.220) cited above where the engines are mounted at the rear and on top of the fuselage so that their noise is shielded by a ‘V’ shaped fin/tail plane assembly.

In order to investigate more unconventional designs Cambridge University and the Massachusetts Institute of Technology set up a collaborative research team with other industry partners including Cranfield University, Luton Airport, and Boeing. The team’s question was, ‘Starting with a blank piece of paper, can one design a mid-range passenger aircraft that is inaudible outside a typical airport?’⁶⁰ The solution they have come up with is called SAX-40. (Fig. 1.13 p.218)

This design is an innovative development featuring novel engine technology as well as a wing/fuselage combination known as a Blended Wing Body. In addition, ‘in an idea

⁵⁶ A350 Xwb Technology.

⁵⁷ Quoted in Zoe Kleinman, *How Are Aeroplanes Getting Quieter?* (2013 [cited 19th September 2013]); available from <http://www.bbc.co.uk/news/technology-23260462>.

⁵⁸ Tim Bowler, *Carbon Fibre Planes: Lighter and Stronger by Design* (2014 [cited 28th January 2014]); available from <http://www.bbc.co.uk/news/business-25833264>.

⁵⁹ Georgios C. Doulgeris, 'Modelling & Integration of Advanced Propulsion Systems' (Cranfield, 2008), 216.

⁶⁰ Ann Dowling and Ed Greitzer, 'The Silent Aircraft Initiative – Overview,' in *45th AIAA Aerospace Sciences Meeting* (Reno: 2007).

borrowed from nature's quietest fliers, owls,⁶¹ trailing edge brushes are used to dampen air-flow noise from the wings. The Blended Wing Body is not a totally new idea. Its history includes the Northrop YB-49, an unsuccessful late 1940's American bomber project, and the Northrop B-2 Spirit, a current American 'stealth' bomber.⁶² (Fig.1.14 p.218) More recently a collaboration between NASA and Boeing, which also included Cranfield University, has seen the development and flight testing of a radio controlled scale model Blended Wing Body, the X-48C.⁶³ (Fig.1.15 p.219) However, for an industry that favours gradual innovation the production of airliners with this configuration represents a very large step.

Concurrent research carried out at Cranfield University has demonstrated that 'the most silent, efficient, and green airframe, is the most costly'⁶⁴ and is this Blended Wing Body. Part of the reason for the high cost is the need to develop the new technologies required to build the novel shape as a production aircraft and to ensure that the stringent legislative requirements for airliners are met. These will take time and it is anticipated that such an airliner would not be available until 2050. How long it takes for a creative new development in technology to become available depends on what is involved by way of novelty and the complexity of demonstrating that it is safe and also conforms to other regulatory requirements imposed by governments. This may take decades for a novel passenger aircraft design because of the rigorous research and testing involved. Apart from governmental regulations the manufacturers know that in the competitive world they inhabit they cannot afford to make a mistake in bringing a new product to the market because the result could be bankruptcy. In view of the four decades it was anticipated it would take to adequately develop a Blended Wing Body airliner the research at Cranfield also aimed at determining whether there might be a design of aircraft, less ambitious than the Blended Wing Body, which could serve to reduce noise as a nearer-term achievable step on the way to the more advanced design.

⁶¹ Dan Thisdell, *Uk Researchers Unveil Silent Aircraft Concept* (Flightglobal, 2011 [cited 26th July 2013]); available from <http://www.flightglobal.com/news/articles/uk-researchers-unveil-silent-aircraft-concept-364961/>.

⁶² Robert Jackson, 'Offensive Aircraft in a New Age,' in Philip Jarrett (ed.), *The Modern War Machine, Putnam's History of Aircraft*. (London: Putnam, 2000), 126f.

⁶³ Nate Hulings, *X-48c Research Aircraft Wraps up Flight Tests* (Boeing, 2013 [cited 26th July 2013]); available from http://www.boeing.com/Features/2013/04/bds_x48c_04_24_13.html.

⁶⁴ Sunil Mistry, 'A Novel Airframe Design Methodology for Silent Aircraft' (Cranfield, 2008), 124.

To do this an intellectual process was designed which would generate a range of options and then evaluate them in order to focus on the best feasible design. This creative process involved ‘group brain-storming sessions’⁶⁵ in which teaching staff and researchers together came up with a range of potential designs which were divided into broad types. The suggestions ranged from conventional approaches to more innovative possibilities (Fig.1.16 p.219)). The brain-storming sessions then went on to evaluate the designs with each being awarded a score in respect of a range of attributes⁶⁶ (noise, cost, comfort etc.). A table had been drawn up in which each attribute was weighted according to its perceived importance for the final design, e.g. noise being more important than comfort (Fig.1.17 p.219). What has been described here is the creative work of a group of people in which each member brings their own imagination and experience to bear on a particular problem. The exercise was not simply to produce a design to satisfy noise requirements but first of all to create a novel process by which the design decisions could be made.

One result of this exercise was the conclusion referred to above that the Blended Wing Body design was potentially the most effective and the most costly to produce. A possible intermediate design, known as a ‘Broad Delta’ was then identified, developed, and analysed in great detail. (Fig.1.18 p.220) This design is argued to be a viable intermediate step towards the longer term production of a Blended Wing Body airliner.⁶⁷

Team work in design has been a major feature of the current attempts to solve this particular problem of airliner noise as well as having a section in this chapter to itself. However there is a sense in which every individual and team works in the context of a wider historical team of people whom they may never have met.

1.2.8 Building on the work of others

The Wright brothers were dependent on the works of others, and not just those directly engaged in aviation. Richard Rathburn, the then secretary to the Smithsonian Institution, responded to Wilbur Wright’s letter requesting help by directing his staff to assemble

⁶⁵ John P. Fielding et al., 'Development of Silent Airframe Concepts and Innovative Cycle Propulsion Systems for Reduction in Aircraft Noise,' in *25th International Congress of the Aeronautical Sciences* (Hamburg: 2006), 6.

⁶⁶ Mistry, 'A Novel Airframe Design Methodology for Silent Aircraft', 25.

⁶⁷ Ibid., 140f.

suitable materials to send in return. From these the brothers were able to gain an understanding of the problems relating to flying. Rathburn could have ignored the letter as from another crank but instead he took ‘the most decisive and influential action ever undertaken by any Smithsonian administrator’⁶⁸ and took his place as one who aided the Wright brothers in their success. Their creativity can also be seen in the way they transferred existing bicycle technology to the construction of their flying machines as Fisk and Todd reveal.⁶⁹ They corresponded with and became friends with Octave Chanute whose 1894 book,⁷⁰ summarising a wide range of attempts by many people to build flying machines, was one of the ones sent by Rathburn. Chanute, an experienced bridge builder, was carrying out his own experiments with triplane and biplane gliders based on the principle of the ‘Pratt’ Truss which Caleb and Thomas Pratt had patented for bridge building using iron in the early 1840s.⁷¹ It was this trussed biplane that the Wright brothers, reconfigured to allow wing warping, developed.

Whilst bicycle engineering and Chanute’s biplane design were useful for the Wright brothers to build on other extant work was not. They struggled with the development of their early gliders because the tables of aeronautical data assembled by Lilienthal were not accurate. They were therefore ‘forced to rely on themselves to a large degree and to work out many problems, large and small, that plagued their work.’⁷² To obtain more accurate figures they modified a bicycle and built a wind tunnel so that they could systematically gather the data concerning the relationship of lift and drag on wind speed for various wing shapes.⁷³ This research resulted in their eventual success.

This building on the work of others is a feature of creativity in any sphere of work and is a consequence of the proposed ‘10-year rule’ that ‘immersion in a discipline’⁷⁴ is required by an individual before significant creative achievement can happen. This is true in the case of Kekulé’s creative contribution to organic chemistry. However caution has to be applied to the precise usage of the rule. It took the Wright brothers seven years of

⁶⁸ Hallion, *Taking Flight*, 181.

⁶⁹ Fisk and Todd, *The Wright Brothers from Bicycle to Biplane*, 129.

⁷⁰ Octave Chanute, *Progress in Flying Machines*, Dover 1997 ed. (New York: American Engineer and Railroad Journal, 1894).

⁷¹ Hallion, *Taking Flight*, 175ff.

⁷² Robert W. Weisberg, ‘Creativity and Knowledge: A Challenge to Theories,’ in Robert J. Sternberg (ed.), *Handbook of Creativity*. (Cambridge: Cambridge University Press, 1999), 244.

⁷³ Hallion, *Taking Flight*, 193.

⁷⁴ Weisberg, ‘Creativity and Knowledge: A Challenge to Theories,’ 231.

focussed but part-time work to achieve their goal once sparked into action by Lilienthal's death. Dalton, who transformed the study of chemistry, was a meteorologist rather than a chemist. He brought a different paradigm to bear on problems and taught chemists to ask questions 'previously restricted to physics and meteorology.'⁷⁵ Dalton, though, did have the published work and results of earlier chemists at hand. When Rutan created his 'Boomerang' design with all its novelty he did have all the knowledge and techniques gathered by others to work with. It is quite clear that, however applicable the '10-Year Rule' is, creativity in aviation does and will depend on the work of others and past creativity is soon taken for granted.

1.2.9 Creativity is taken for granted

Hallion's retrospective analysis of the Wright brothers' contribution as consisting of 'control', 'integrating diverse technologies', and 'progressive flight research and flight testing'⁷⁶ sounds rather mundane and can obscure the imaginative and creative thought that was necessary. Once any technology has become established human beings take for granted all the creative insight and ingenuity that brought it into being. The same is true of R.J. Mitchell's design of the Spitfire. It has been commented that it 'was a straightforward merger of all the technical knowledge of the time into one composite piece of machinery, including its powerplant.'⁷⁷ This is the wisdom of hindsight. The merging of the knowledge of structural possibilities with current aerodynamic expertise, not to mention everything to do with powerplants, fuel tanks, undercarriages, weaponry, instrumentation etc. might seem 'straightforward' in retrospect but it requires much creativity and ingenuity allied with practical insight.

John Milton's seventeenth century words are entirely fitting not just to the Wright brother's breakthrough and Mitchell's Spitfire but to all technological development:

'The invention all admired, and each how he
To be the inventor missed, so easy it seemed
Once found, which yet unfound most would have thought
Impossible;'⁷⁸

⁷⁵ Thomas S. Kuhn, *The Structure of Scientific Revolutions*, 3rd ed. (Chicago: University of Chicago, 1996), 139.

⁷⁶ Hallion, *Taking Flight*, 185.

⁷⁷ Andrews and Morgan, *Supermarine Aircraft since 1914*, 213.

⁷⁸ John Milton, 'Paradise Lost,' (1667), Book VI, line 498ff.

As developments become established the imaginative mental framework by which we understand the world changes to accommodate the new and so what was surprising becomes obvious because it fits in with our new framework of understanding.

1.3 Summary and moving forward

It has been clearly demonstrated in the foregoing sections that in the prehistory of powered, sustained, and controlled flight and its subsequent development a great deal of creative thinking by individuals and groups of designers and engineers has taken place. This has been concerned not just with the design of aircraft but also with the way they are manufactured. Much of this creativity is taken for granted, and undervalued, by the travelling public who now expect to be flown cheaply from city to city in comfort and safety. Along the way there have been individual flashes of inspiration and collaborative exercises involving experience and imagination. No doubt many expressions such as 'what if?', 'just suppose', and 'why don't we?' will have been used and continue to be used in this creative technological endeavour. Each new creative proposal will have to be proved against a reality that includes not only nature but also government legislation and public perceptions. All the work involved in design and analysis aims to eliminate risk but if real novelty is proposed then there may be a disastrous gap in knowledge as with the Comet airliner when 'De Havilland and BOAC had taken too big a leap.'⁷⁹

There is risk involved in technological creativity. Accidents leading to loss of life are a clear risk and financial risk has already been referred to in section 1.2.7 above. There is also the risk to personal and corporate reputation and prestige. Attempts are made to reduce and even eliminate risk by thorough research, testing, and double checking calculations as well as by meticulous inspection of the production process. Whilst this leads to caution there is money at stake and the fear of a competitor getting ahead pushes towards getting the new product to market as fast as possible. In these situations risk assessment is a necessary and complex business having to take in as well the opinions of the engineers, marketing researchers, and sales people who may be taking an over optimistic view of their latest brain child. Genuine creativity involves novelty and thereby risk in some form. This raises the question as to whether God took a risk in creation, a question to which we will return later in this thesis.

⁷⁹ Ian Goold, 'The Modern Jet Airliner - the Trailblazers,' in Philip Jarrett (ed.), *Modern Air Transport, Putnam's History of Aircraft*. (London: Putnam, 2000).

Aviation is only one branch of modern technology. No doubt similar sections could have been written for many of the others⁸⁰ such as road transport, railways, marine engineering, chemical engineering, telecommunications, entertainment, medicine, robotics, and so on. Even though human ingenuity and creativity could be clearly demonstrated in similar ways in every other branch of technology there has been very little theological interaction with these subjects. Notable recent exceptions include Cheek's interaction with intelligent transport systems⁸¹ and DeLashmutt's analysis of the culture of information technology.⁸² Human creativity underlies technology, modern, pre-modern and prehistoric. This gives a clear expectation that any theological engagement with technology will have to consider the reality of human creativity in a significant way. As will be shown in the next chapter such an expectation is disappointed when actual theological writings which seek to engage with technology are consulted. In the main theology deals with an objectified technology that seems detached from the human activity that engenders it. As a result Christian engineers and technologists will find little to recognise in such theologies.

The purpose then of this thesis is to begin to remedy this omission by opening up a strand of Christian thought about technology focussed on human creativity and its place within the purposes of God. This process will begin by considering theological approaches to thinking about technology particularly an attempt to use the categories that formed the basis of Richard Niebuhr's 'Christ and Culture.'⁸³ Dissatisfaction with the results of this is then the spur to investigate human creativity, divine creativity as the origin of and imaged in human creativity, followed by the 'dark side' of creativity, and then a specific case of creativity in technology exemplified in the development of cities in succeeding chapters. This is then followed by an analysis of the way the pre-history of modern technology was influenced by the Christian faith especially by a mistaken interpretation of the 'image of God' prior to Enlightenment rationalism controlling the development of technology into the twentieth century. The eschatological concerns opened up in the chapter on the city are then pursued in a consideration of God's purposes and God's way

⁸⁰ for a few examples see Francis Spufford, *Backroom Boys* (London: Faber & Faber, 2003).

⁸¹ Cheek, 'Theology & Technology: An Exploration of Their Relationship with Special Reference to the Work of Albert Borgmann and Intelligent Transportation Systems'.

⁸² Michael W. DeLashMutt, 'Sketches Towards a Theology of Technology: Theological Confession in a Technological Age' (PhD, Glasgow, 2006).

⁸³ H. Richard Niebuhr, *Christ and Culture*, 1st ed. (London: Faber and Faber, 1952).

of acting. The final summary chapter brings to a conclusion the theme of human technological creativity being a gift from God to be used in appropriate ways to develop God's creation and new creation.

It should be noted that no attempt is being made to provide a formal and consistent definition of technology for the purpose of this thesis. The difficulty of formulating an appropriate one can be seen in Cheek's otherwise useful definition of technology as 'the application of knowledge, tools, skills, and systems to solve practical problems, extend capabilities, and expand opportunities to meet or invoke human needs'⁸⁴ which appears to exclude creativity. When he does acknowledge that human creativity must rise 'to the challenge of creating new and appropriate technologies'⁸⁵ the ongoing creativity needed to apply and develop such technologies, once they have been created, appears to go unnoticed. It can also be noted that McClellan and Dorn, in their magisterial review of the complex history of science and technology, state their view that the definition of technology as 'applied science' is an artefact of today's cultural attitudes superimposed without warrant on the historical record.⁸⁶ They then proceed without further definition.

⁸⁴ Cheek, 'Theology & Technology: An Exploration of Their Relationship with Special Reference to the Work of Albert Borgmann and Intelligent Transportation Systems', 27.

⁸⁵ Ibid., 271.

⁸⁶ James E. McClellan III and Harold Dorn, *Science and Technology in World History*, 2nd ed. (Baltimore: John Hopkins University Press, 2006), 1.

Chapter 2

Mapping the Relationship between Theology and Technology

2.1 Mapping through Philosophy

In the previous chapter the justification for seeking a theological understanding of technology which includes human creativity at its heart has been laid out. Philosophy presents itself as a possible starting point because there has been a long tradition of philosophical theology from the early centuries of the Christian church and philosophers have taken an interest in technology itself. Heidegger, for instance, locates the essence of technology as a ‘challenging setting-upon through which what we call the real is revealed as standing-reserve.’⁸⁷ He avers that the essence of technology cannot be anything technological just as the essence of ‘tree’ is not itself a tree and he specifically refuses to be satisfied with an understanding of technology as a human activity which is a means to an end. Certainly technology is not simply a means to an end but it is a human activity, possible because of the capacity human beings possess to be creative. Because Heidegger excludes this it is clear that he will be of no immediate value in a project which is seeking to understand technology from a viewpoint he is excluding.

However it is worth listening further to him. The ‘challenging’ mentioned above is carried out by human beings because they themselves are challenged to do this challenging. This represents a danger for them in that they perceive themselves as ‘standing-reserve’ (human resources) and, because they forget that they are hearers of this challenge, they set themselves up as lords ‘of the earth.’⁸⁸ Heidegger does not specify precisely the origin of this challenge or indeed what it is in human beings that enables them to respond to it. What is argued through the rest of this thesis is that God is the origin of this summons made to human beings, created in God’s image, with the potential for creativity which enables them to act in accordance with the summons. However the understanding of the image of God has become distorted resulting in the summons being misunderstood with human beings regarding the natural world as existing for their sole benefit. This is what leads to the human arrogance to which Heidegger has referred.

⁸⁷ Martin Heidegger, ‘The Question Concerning Technology,’ *The Question Concerning Technology and Other Essays*. (New York: Harper & Row, 1977), 18.

⁸⁸ *Ibid.*, 27.

Heidegger's main concern is with modern technology as it is this which most clearly exhibits the characteristics he understands to be the essence of technology. However he notes that this challenging lies also behind the rise of modern physics prior to the rise of technology as we know it now. Certainly the notion that a better understanding of the natural world would lead to improvements benefitting human beings lay behind the rise of modern science: 'Atropos pays us less attention while Lachesis spins us an addition.'⁸⁹ The success of this venture reinforces the assumptions that it started with. Human beings forget that they are hearers of the summons as well as those who do the challenging. God is no longer relevant in this understanding of reality. This aspect of modern science and technology will be further explored in chapter 7.

Whilst a fuller analysis of Heidegger is not appropriate at this point, for reasons stated above, one practical effect of his method needs to be highlighted. He argues against understanding technology as 'some mythological understanding'⁹⁰ but the very act of not dealing with the human aspects of technology and making scant reference to actual technologies means that he treats technology as if it is a 'thing, or at least a force, as if it had an existence of its own.'⁹¹ In this way technology has been objectified or 'reified.'⁹² Because of this and the neglect of the human creative aspects of technology it is 'doubtful whether any engineers could recognize themselves'⁹³ in his philosophical analyses and descriptions.

It has to be emphasised that the fact that technology is quite clearly a human enterprise is important theologically because of the centrality of the Incarnation of Jesus Christ to the Christian faith. God's commitment to and valuing of, not just human beings, but also the material universe and human culture is demonstrated by the act of the Son of God taking a human body and living in the world which was created by God. Because God values this material world what happens to it through human technology matters as human beings are ultimately responsible to God for it.

⁸⁹ Antoine Houdar de la Motte (1672-1731) quoted in André Malet, 'The Believer in the Presence of Technique,' in Carl Mitcham and Jim Grote (eds.), *Theology and Technology*. (University Press of America, 1984), 91.

⁹⁰ Heidegger, 'The Question Concerning Technology,' 31.

⁹¹ Samuel C. Florman, *The Existential Pleasures of Engineering* (New York: St. Martin's Press, 1976), 48.

⁹² DeLashMutt, 'Sketches Towards a Theology of Technology: Theological Confession in a Technological Age', 65.

⁹³ Carl Mitcham, *Thinking through Technology*, 1st ed. (Chicago: University of Chicago Press, 1994), 142.

Heidegger is not alone in objectifying technology apart from the human ways in which it comes into being. When Habermas defines technology as the ‘scientifically rationalized control of objectified processes’⁹⁴ he is forcing it into a particular shape for the purposes of his understanding. He treats it as an object that behaves according to certain laws which we are going to discover. But technology is a human endeavour including ‘a complex of decisions and operations that are constantly under way.’⁹⁵ Philosophical studies are often motivated by the feeling that technology is a worrying phenomenon. However identifying technology as a ‘thing’ hides the fact that the problem is with human ideas and decisions at many different levels. Habermas’ desire to make technical means to serve democratic ends would be better served by identifying and acknowledging human involvement in the whole process.

If Heidegger and Habermas are of little help to our investigation the same is true for Jonas. He tries to grasp the ‘pervasive “process properties” by which modern technology propels itself – through our agency, to be sure – into ever succeeding and superceding novelty.’⁹⁶ By not carrying out a serious analysis of ‘our agency’ he has cast technology as a deterministic enterprise which we can examine as external observers. But it is human knowledge and decisions, good, bad and indifferent, that make technology what it is and we cannot leave them out. It is undoubtedly the case that human survival and prosperity, from an evolutionary perspective, has depended on our ability to perceive patterns in nature. This has enabled us to understand our surroundings and adapt them to our purposes through technology. But we can also be fooled into seeing patterns where they do not actually exist and making decisions that are proved to be wrong because the pattern was not actually there. Taleb uses the phrase ‘black swan event’⁹⁷ as a rare event which goes against expectations because the perceived pattern of events was mistaken even though it appeared to be obvious. Jonas also observes the restless nature of technology and attributes this to science itself, which appears to offer incessant novelty, rather than to the restlessness of human beings as observed by George Herbert in his

⁹⁴ Jürgen Habermas, ‘Technical Progress and the Social Life-World,’ in David M Kaplan (ed.), *Readings in the Philosophy of Technology* 1st ed. (Lanham: Rowman and Littlefield, 2004), 85.

⁹⁵ Pattison, *Thinking About God in an Age of Technology*, 64.

⁹⁶ Hans Jonas, ‘Towards a Philosophy of Technology,’ in David M Kaplan (ed.), *Readings in the Philosophy of Technology* 1st ed. (Lanham: Rowman & Littlefield, 2004), 17-18.

⁹⁷ Nassim N Taleb, *Foiled by Randomness. The Hidden Role of Chance in Life and the Markets* (London: Penguin Books, 2007), 4 & 116-21.

poem ‘The Pulley’⁹⁸ first published in 1633. Human mistakes and restlessness are also part of technology.

Finally in this section on the philosophical understanding of technology it should be noted that in the collections of essays assembled by Mitcham and Mackey⁹⁹, and Kaplan¹⁰⁰ there is no listing of ‘creativity’ in the indices. It appears to have no relevance to the matter in hand.

2.2 Mapping using a Theology and Science Model

It is quite clear from the foregoing that this objectifying of technology, which is similar to portraying ‘science and religion as hypostatized forces,’¹⁰¹ will be of no direct help in the development of a realistic theology of technology. Therefore the approach through philosophy has to be left to one side and a different approach sought. One factor concerning modern technology that is often noted is its dependence on the development of modern science. The relationship is actually symbiotic for just as technology needs the knowledge of science so science needs technology to develop the apparatus to test its theories and probe deeper into nature. The discussions about the relationship between theology and science may present an entry point into an understanding of technology. The response of ecclesiastical authority to the scientific innovations of Galileo and Darwin may appear to suggest that the relationship between theology and science is that of warfare but deeper investigation reveals a far more complex situation.

Barbour devoted part of his Gifford lectures to laying out the different ways in which people had depicted the ‘ways of relating science and religion’¹⁰². He discerned four principal relationships which he described as: conflict, independence, dialogue, and integration. However Barbour is not the only scholar to have explored these possibilities and different perspectives yield different results. Drees works out a more complex and broader set of relationships by first identifying the various challenges that science brings;

⁹⁸ Joseph H Summers, ed., *George Herbert: Selected Poetry*, 1st ed., *The Signet Classic Poetry Series* (New York: New American Library, 1967), 220.

⁹⁹ Carl Mitcham and Robert Mackay, eds., *Philosophy and Technology*, 1st paperback ed. (New York: The Free Press, 1983).

¹⁰⁰ David M Kaplan, ed., *Readings in the Philosophy of Technology* (Lanham, Maryland: Rowman & Littlefield, 2004).

¹⁰¹ John H Brooke, *Science and Religion. Some Historical Perspectives*, 1st ed. (Cambridge: Cambridge University Press, 1991), 42.

¹⁰² Ian G. Barbour, *Religion in an Age of Science*, 1st ed. (New York: HarperCollins, 1990), 3-30.

new knowledge, new views of knowledge, and appreciation of the world. These challenges are then married up to the different aspects of the character of religion; cognitive, experience, and tradition, producing a nine-fold interaction with some subdivisions.¹⁰³ However science is not a monolithic enterprise. There are many different branches with varying assumptions, paradigms, and methods of exploration. Chemistry is not the same as astro-physics, which is not the same as geology, and so on. There is variation in the different fields of science over time and religion is not a uniform entity either. ‘There is no such thing as *the* relationship between science and religion. It is what different individuals and communities have made of it in a plethora of different contexts.’¹⁰⁴

With all this complexity the different ways in which the relationship has been characterized might yet provide some models for exploring technology, but there is a similarity between science and theology that does not exist between theology and technology. Both science and theology are forms of knowledge derived from investigations of the world in which we find ourselves, albeit with different boundaries, assumptions, and methods. Barbour noted that his ‘typology was developed for fundamental science as a form of knowledge’ and ‘not for applied science in its impact on society and nature.’¹⁰⁵ This means that these various models will not be appropriate to an exploration of the relationship between theology and technology.

Neither the philosophy of technology nor models of the relationship between science and religion give a suitable starting point to develop a theological understanding of technology. Technology is about human agency adapting the world and so technology, in this context, must be viewed as an aspect of human culture. To do this is not to reduce technology to an activity which is a means to an end as Heidegger assumed as there are varied stimuli behind technological development. Pacey comments on the century of invention, 1250 – 1350, that it was a ‘period when much of the most advanced technology was stimulated by imaginative and not material motives.’¹⁰⁶

¹⁰³ Willem B. Drees, *Religion, Science and Naturalism*, 1st ed. (Cambridge: Cambridge University Press, 1996), 45.

¹⁰⁴ Brooke, *Science and Religion. Some Historical Perspectives*, 321.

¹⁰⁵ Ian G. Barbour, *When Science Meets Religion*, 1st ed. (London: SPCK, 2000), 4.

¹⁰⁶ Arnold Pacey, *The Maze of Ingenuity* (Cambridge, Massachusetts: MIT Press, 1976), 86.

2.3 Mapping using Niebuhr's 'Christianity and Culture' Model

The relationship between Christian faith and technology is not a simple one and various Christian writers and theologians have adopted different attitudes to what is a primary component of everyday life in the developed parts of the world. To assist the discussion of such viewpoints Carl Mitcham and Jim Grote compiled a series of essays¹⁰⁷ the first five of which were intended to explore the territory using the categories developed by Richard Niebuhr in his analysis of the relationship between Christian faith and culture.¹⁰⁸ Niebuhr was not referring to the 'high culture' of the arts but rather to the world of culture in so far as it is the 'man made and man-intended'¹⁰⁹ context in which we live our everyday lives. Mitcham and Grote's decision was correct because contemporary culture is a 'technologically advanced style of life.'¹¹⁰ Niebuhr developed his five categories with two polar opposites; 'Christ against culture' and 'the Christ of culture', plus three intermediate positions; 'Christ above culture', 'Christ and culture in paradox' and 'Christ the transformer of culture'. The essays presented by Mitcham and Grote under these headings give a useful range of viewpoints. The rest of this chapter will be a series of expositions and discussions of these essays. Three other authors have been found whose writings fit into Niebuhr's polar opposite categories. These writings will also be considered under the appropriate headings. The purpose of this exercise will be to expose the lack of engagement of theologians with human creativity in their considerations of technology

2.4 Christ against culture

2.4.1 George Blair - Technology as alien to Faith

Niebuhr presents the position of Christ against Culture as one which arose early in the history of the Church and which, superficially at least, appears to be more logically consistent with the Gospel message¹¹¹ because a Christian's allegiance to Jesus Christ as his risen Lord takes priority over all earthly allegiances and activities. However the attempt to use Niebuhr's 'Christ and Culture' categories in the context of technology runs into a problem with the very first essay by George Blair which is intended to

¹⁰⁷ Carl Mitcham and Jim Grote, eds., *Theology and Technology* (Lanham: University Press of America, 1984).

¹⁰⁸ Niebuhr, *Christ and Culture*.

¹⁰⁹ *Ibid.*, 48.

¹¹⁰ Albert Borgmann, *Power Failure* (Grand Rapids: Brazos Press, 2003), 11.

¹¹¹ Niebuhr, *Christ and Culture*, 44.

demonstrate this opposition between Christ and technology. This happens because Blair believes that the technological use of our world for our own purposes ‘can be Christianized quite easily’ and ‘technology as such is not anti-Christian.’¹¹² It is ‘technique’ which is the problem because Christianity ‘involves a way of looking at things that is foreign to the way in which the technical mentality views things.’¹¹³ The principal issue with technique is that human beings see themselves as the efficient cause in making things happen and regard God’s creation as something which has no purpose other than to serve them. This clearly focuses upon the attitudes of people towards the rest of God’s creation as being the underlying problem of technique for Christianity rather than technology itself. This technical mentality is evident in wide areas of life and, Blair argues, can easily infect Christians who ‘want to turn Christianity into a plan for action.’¹¹⁴ Instead of making plans Christians, he believes, should play, have fun, and be happy in a world that is not to be taken seriously. They should follow the example of God who acts for the sake of the act itself and is ‘infinitely happy whatever the world chooses to make of itself,’ ‘even the eternal misery of souls in hell.’¹¹⁵ All this results from Blair’s philosophical understanding of God being immutable and impassible.

According to Blair God loves us, dies to save us from our sins because God can, but has no ultimate purpose for the created order. But if God has abdicated the role of providing purpose and meaning for the universe and is happy for it to unfold in whatever way it does then it is difficult to see why human beings should not display the attitudes of ‘technique’. It is not clear why the hubris he condemns in the ‘technical mind’ is wrong. This question becomes even more pointed when it is realized that Blair has succumbed to hubris in assuming that it is possible for human beings through our philosophy to view the world as God does, that is to say we have the intellectual capacity to transcend creation in the way that God does. Furthermore his picking on immutability and impassibility as key characteristics of God betrays the Greek philosophical origins of his thought which cause the Biblical revelation of God to become subservient to and constrained by them.

¹¹² George A. Blair, ‘Faith Outside Technique,’ in Carl Mitcham and Jim Grote (eds.), *Theology and Technology*. (Lanham: University Press of America, 1984), 46.

¹¹³ *Ibid.*, 45.

¹¹⁴ *Ibid.*, 48.

¹¹⁵ *Ibid.*

It is this preference for a philosophically based understanding, rather than a biblically based one, that is the origin of the contradiction of a God who loves us but doesn't actually care and is indifferent to our fate. It is very difficult to make sense of the Christian doctrines of the Trinity and the Incarnation with the suffering, death, and resurrection of Christ, understood to be the second person of the Trinity, and hold on to immutability and impassibility as somehow defining absolutely the nature of God. The resurrection of Christ is especially significant as it is the promise and guarantee of 'redemption and renewal'¹¹⁶ and is 'an unusual sign'¹¹⁷ of God's faithfulness to the whole of creation.

Blair's thinking also lacks an eschatological element, indeed it would be out of place for the world is created because God can and does rather than because God has a purpose. God has no particular goal for creation and it is a mistake to imagine that we can know the purposes and finalities of the created world because there aren't any to know, rather than because of the limitations of our finite created nature.

In spite of this Blair's argument that human self-centered arrogance expressed in technique, which underlies some of the development of technology, is in conflict with Christianity is still of value, even though he does not fit into the 'Christ against Culture' slot where Mitcham placed him. To say that Christ is against technology is to affirm that technology has no place in the purposes of God and human beings have turned to it as an expression of their opposition to God's purposes for them. Jacques Ellul is considered by some to regard modern technology as an 'autonomous demonic power'¹¹⁸ so it is appropriate to consider his writings before we go to the next of Niebuhr's categories.

2.4.2 Jacques Ellul - Technique and Faith in confusion

Mitcham and Grote included two contributions by Ellul in Part 2, 'Exegeses of the Christian Tradition', of their collection of essays. Ellul appears to fit better into the role of advocating a rift between Christianity and technology than Blair does. This is because

¹¹⁶ Tom Wright, *Surprised by Hope* (London: SPCK, 2007), 119.

¹¹⁷ David Wilkinson, *Christian Eschatology and the Physical Universe*, 1st ed. (London: T & T Clark International, 2010), 113.

¹¹⁸ Egbert Schuurman, 'A Christian Philosophical Perspective on Technology,' in Carl Mitcham and Jim Grote (eds.), *Theology and Technology*. (University Press of America, 1984), 108.

for Ellul, in these essays, technology arises as a result of the Fall of human beings as described in the Garden of Eden story (Gen. 2.4-3.24).

Before the Fall God's creation was perfect and complete and 'there was nothing to add'¹¹⁹ and no need 'to transform it, to remodel it, to extend it according to its own power.'¹²⁰ There was no place for a co-creator for human beings simply received what God gave. There was work for human beings before the Fall but it was work that we cannot imagine because it did not spring from necessity. The unity and harmony of God's creation was destroyed by the Adam's disobedience leaving only 'the fragments of a shattered mirror'¹²¹ and our inability to understand the nature of God's intended perfection. The dominion granted to human beings (Gen. 1.26-28) is now expressed through technique as they struggle to survive in this broken world. It is therefore not possible to view human technology and techniques and their development as rooted in God's original purposes as expressed in the Garden of Eden. Because of the disruption Adam's disobedience caused in the whole created order and between God and human beings, God sets limits on human behaviour through Old Testament laws 'so that the disorder will be at least viable'¹²² for human beings. An example of this kind of law is that of the Sabbath rest, not just for human beings, but also the seventh year rest for the land. It is the failure of human beings to live within these limits and to recognise their responsibility, as stewards of creation, to God that leads to the ecological crisis that awaits us. However God will have the final word as the Beatitudes indicate:

'The earth will be taken from us, from us as the strong, the exploiters of the world, the technicians, the improvers, the inventors, the conquerors of the galaxies. The way in which we have treated this earth implies that we shall be relieved of it, that God will finally hand it over to those who will finally occupy it well.'¹²³

Ellul grapples with the doctrines of creation, human beings and eschatology and his thinking interacts with the Biblical text. His focus is on technique rather than technology as such, but modern technology is very much the offspring of technique which he defines as the '*totality of methods rationally arrived at and having absolute efficiency* (for a

¹¹⁹ Jacques Ellul, 'Technique and the Opening Chapters of Genesis,' in Carl Mitcham and Jim Grote (eds.), *Theology and Technology*. (University Press of America, 1984), 125.

¹²⁰ Jacques Ellul, 'The Relationship between Man and Creation in the Bible,' in Carl Mitcham and Jim Grote (eds.), *Theology and Technology*. (University Press of America, 1984), 142.

¹²¹ Ellul, 'Technique and the Opening Chapters of Genesis,' 127.

¹²² Ellul, 'The Relationship between Man and Creation in the Bible,' 148.

¹²³ *Ibid.*, 152.

given stage of development) in *every* field of human activity.’¹²⁴ In this reading of the Biblical text Ellul is quite clear that whilst technology has a role in human survival in a fallen world it has no place in the perfect purposes of God. In this respect Ellul places technology and Christianity in opposite camps.

However this straightforward if debatable position is not Ellul’s final position. Even before Mitcham and Grote had incorporated these essays into their collection Ellul had expressed a completely different outlook declaring that ‘the Bible presents man’s constant invention of the artificial as his “vocation”, his role.’¹²⁵ This is true before and after the fall, the difference being that in the latter case the environment has become hostile to human beings who now use their technique to express the artificial. This places human creativity in technology within the purposes of God. Adam’s work in the garden is now understood as enhancing the garden in an artificial way and not ‘simply watching growing whatever is growing.’¹²⁶ This contradiction is not ‘due to the dialectical ‘both-and’ structure of his thought but to changes and developments within his theological position.’¹²⁷ The clue to the change is the use of the word ‘artificial’ for in this later essay Ellul is arguing against an almost idolatrous view of nature and the natural and insisting that the creation of the artificial is a proper role for human beings. ‘To glorify the natural...is precisely to practise the idolatry condemned in the Bible.’¹²⁸ In the essays reprinted by Mitcham and Grote he is objecting to the use of the term ‘co-creator’ for human beings because it seems to bestow some of God’s glory upon them for in the ‘theory of man’s demiurgic function ...there is always an honour stolen from God.’¹²⁹

Ellul understands that in the modern world human technique, originally an expression of human freedom has become autonomous and enslaved human beings. This problem can only be solved if ‘all men adopt the same values and the same behaviour.’¹³⁰ Human beings need to recognise both the ‘rudimentary lesson that history and nature have been

¹²⁴ Jacques Ellul, *The Technological Society*, trans. John Wilkinson (New York: Vintage Books, 1964), xxv.

¹²⁵ Jacques Ellul, ‘Nature, Technique and Artificiality,’ in Paul T. Durbin (ed.), *Research in Philosophy and Technology* 1st ed. (Greenwich, Connecticut: JAI Press, 1980), 267.

¹²⁶ *Ibid.*

¹²⁷ Andrew Goddard, *Living the Word, Resisting the World*, 1st ed. (Carlisle: Paternoster Press, 2002), 59.

¹²⁸ Ellul, ‘Nature, Technique and Artificiality,’ 273.

¹²⁹ Ellul, ‘Technique and the Opening Chapters of Genesis,’ 126.

¹³⁰ Jacques Ellul, ‘The Technological Order,’ in Carl Mitcham and Robert Mackay (eds.), *Philosophy and Technology* 1st ed. (New York: The Free Press, 1983), 90.

trying to teach us about limits' and our present situation as people who 'either must limit themselves or be limited.'¹³¹

The shift in Ellul's understanding highlights the importance of the Biblical stories of creation at the beginning of Genesis. How these, and other texts, are interpreted is significant for understanding the place of human creativity and technology within the purposes of God. In a later chapter these texts will be considered in greater depth. What has been demonstrated in this examination of the writings of Blair and Ellul is the difficulty of placing technology in opposition to Christianity. We now turn to the essay by Fudpucker to see how well they can be held in harmony.

2.5 The Christ of culture

2.5.1 Wilhelm Fudpucker - Technology bringing in the Kingdom of God

For Wilhelm Fudpucker there is no inherent opposition between Christianity and technology for the former has been the sponsor of modern technology and the latter is creating a world that is increasingly Christian. Starting with Weber and Bacon's understanding of Christian moral principles as yielding the notion that 'pity and the flight from suffering leads to the idea of freedom' Fudpucker draws in Hegel's understanding that the perception 'man *qua* man is free' arose in Christian spiritual consciousness. This perception eventually finds 'worldly incarnation in the culture of the modern industrial state.'¹³² Moreover the invention and usage of technological instruments were part of Christian spirituality between the 9th and 15th centuries and discipline (temperance) was elevated as a virtue to a dominant position within the rationally regulated life.

Fudpucker adopts White's five strands to the origin of these attitudes. 1) Genesis speaks of the world as a created artifact showing intelligent craftsmanship and design with human beings, created in the Image of God, participating with God in ruling creation. 2) Exodus shows that history is linear leading to some definite end with people called to play a part through their worldly activities. 3) The life of Christ, including his resurrection, shows that matter is not evil but created for some spiritual purpose and destined for regeneration. These three are supplemented by 4) the Judeo-Christian de-

¹³¹ Douglas John Hall, 'Toward an Indigenous Theology of the Cross,' in Carl Mitcham and Jim Grote (eds.), *Theology and Technology*. (University Press of America, 1984), 263.

¹³² Wilhelm E. Fudpucker, 'Through Technological Christianity to Christian Technology,' in Carl Mitcham and Jim Grote (eds.), *Theology and Technology*. (University Press of America, 1984), 54.

animization of nature and 5) the Christian concern for the material well-being of others. Fudpucker can then claim that the Christian faith is not just hospitable to technology but also encourages its development. 'Clearly *techné* is not foreign to the Kingdom of God.'¹³³

This historical argument that Christianity has been inherently technological in its inner thrust and social influence is complemented by studies showing that the kind of social change that technology brings about conforms objectively to the most general and profound of Christian ideals. Fudpucker uses the works of Pierre Teilhard de Chardin and Walter Ong to argue that human science and technology are the latest stage in an ordered development starting with geological and then biological evolution. Ultimately the planet wide communications network which has been brought into existence will bring about a new level of human consciousness releasing a dynamic of hyper-personalism pressing towards the 'Omega point'¹³⁴ the culmination of history. He is arguing that the divine driving force behind evolutionary change is also behind technology, in total harmony with the Christian faith, which will take us to our final destiny in accordance with the will of God. 'Technology is an anonymous Christianity waiting to be named'¹³⁵ to which we must submit in obedience to God and not be fearful of it. Fudpucker is dismissive of those who say that evolution appears more haphazard than ordered claiming they are overwhelmed by particulars and fail to see overall progress. To those who draw attention to the aberrations of, say, Nazi death camps and environmental pollution, he deems these to be the result of deformed technology caused by political constraints and economic demands.

Wilhelm Fudpucker sits squarely in the slot provided for him in Mitcham's scheme as for him Christianity and technology are in fundamental agreement. However his eschatological view does not allow for any inbreaking of God to renew and recreate the current world order into God's kingdom. The total optimism of this view is no doubt what Douglas Hall has in mind when he criticizes American theology for reflecting the cultural optimism of society and not grasping the dark side of reality. In the American

¹³³ Ibid., 57.

¹³⁴ Ibid., 59.

¹³⁵ Ibid., 63.

Church ‘the faith itself has been identified with the highest aspirations of this culture’¹³⁶ whereas the experience of the war in Vietnam should bring American Christians to a position critical of the technological optimism of their own culture. In other words Fudpucker’s approach is unrealistic because those elements of history he brushes aside reveal the effects of actual technology. He ignores the often unintended harmful side effects as well as the intentional evil use of technical means because he has an unreal view of engineers and what they would achieve without political and economic constraints.

Fudpucker’s view could be described as idolatrous as one of God’s many gifts to human beings, i.e. technology, has displaced God and become in itself the source of salvation for us. However there are other ways of expressing a positive relationship between the Christian faith and technology and to one of those we now turn.

2.5.2 Charles Coulson – True dignity achieved by Faith and Technology

Charles Coulson expressed a very exalted vision of its potential for human beings:

‘I see industry making use of the best possible faculties that people can bring to it, releasing man from the burden of physical toil, so that the deeper parts of his spirit may have time to blossom and to grow. In that sense I see it making possible a richer and a deeper worship than ever he has known before. I see his spirit released as his body has in the last hundred years been increasingly released, so that he may sing God's praises in a new more confident tone.’¹³⁷

Here is technology seen as the bringer of change in the midst of which human beings are seeking their ‘true dignity’ for it is better for ‘man not to have to spend his time and his strength in arduous physical toil, or in squalor, illiteracy and disease’¹³⁸. He does recognise problems that accompany the development of technology mentioning unemployment, puzzlement over what is happening and the dangers from atomic weapons, nerve gases and the like. In respect to the latter dangers he quotes Winston Churchill as saying that our generation and subsequent ones will have to learn to live ‘on the rim of hell’¹³⁹.

¹³⁶ Hall, ‘Toward an Indigenous Theology of the Cross,’ 265.

¹³⁷ C.A. Coulson, *Faith and Technology* (London: Chester House Publications, 1969; reprint, 1974), 19.

¹³⁸ *Ibid.*, 13f.

¹³⁹ *Ibid.*, 14.

In dealing with these problems it is the responsibility of the community as a whole to provide appropriate education for leisure and the understanding of a right relationship with the material world and the world of nature. Education is also needed to deal with the puzzlement that technological change brings and the loss of tradition which ‘lies at the core of nearly all the problems, of conduct, of ethics and morals, of food and population, of education and of power’¹⁴⁰ Christians have a particular role to play in setting these problems in the context of the Kingdom of God for they can bring wisdom and hope to bear in the confused and dangerous situation that the development of technology brings. A proper view of humanity is an essential ingredient for without it technology ‘may do infinite harm. But with it, it may become a tool in the shaping of the Kingdom of Heaven on earth.’¹⁴¹ Coulson understands human beings as children of God who have played no effective part in their own long, tortuous and accidental development but now who are beginning to take over the controls and direct the evolutionary stream. In small ways such as disease control and developing new varieties of plants for food the ‘child of God’ is growing up as God intends. So strong is Coulson’s sense that technology is a tool to advance human dignity and shape the Kingdom of Heaven that participation in the industrialisation of the underdeveloped world, especially Africa and India, is to be seen as a Christian vocation¹⁴².

Coulson does not argue as an academic philosopher or theologian, but he draws from the Christian tradition and echoes of biblical expressions can be heard in his writings besides more direct references to the scriptures. His optimism seems rather out of place in the 21st century. He thought that nuclear power was inevitable for a large part of the world¹⁴³ not knowing that in the UK 40 years later so little progress would have been made in the matter of the disposal of radio-active waste and the promise of nuclear fusion energy has not yet materialised. At the same time the use of fossil fuels has accelerated the process of global warming to a dangerous extent. The various continuing forms of warfare, including terrorism and the use of massive military power, have highlighted the rise of ideologies other than the Christian one and further exposed the dark side of human nature even when acting from a supposedly Christian standpoint.

¹⁴⁰ C.A. Coulson, *Science, Technology & the Christian* (London: Epworth Press, 1960; reprint, 1961), 29.

¹⁴¹ *Ibid.*, 103.

¹⁴² *Ibid.*, 102f.

¹⁴³ *Ibid.*, 15.

The basis for Coulson's optimism is that this world is God's and this 'is the only guarantee that all things can work together for good.'¹⁴⁴ He does not use the word 'optimism' but 'hope' which is 'one of the greatest gifts which the Christian has to give to the secular world.'¹⁴⁵ However his positive view of technological progress, along with his clear intention of inspiring his hearers and readers into action, obscures the Christian doctrine of eschatology and encouraged him to view the Kingdom of Heaven as something that we can help God to bring about in this material world. However he makes two important contributions to the discussion. 'First, this is God's world and we are part of God's plan. Second, we are children of God'¹⁴⁶

2.5.3 Philip Hefner – The Seamless Robe of Evolution, Faith, and Technology

Believing that 'science... becomes an essential component for doing theology'¹⁴⁷ Philip Hefner asserts that the 'bio-cultural continuum is itself a development within the cosmic processes that were unleashed in the singularity that gave birth to the big bang.'¹⁴⁸ Put theologically this means that the whole process of cosmo-bio-cultural evolution is one in which God's creation, understood as a dynamic on-going creation, is developing ever more appropriate structures to relate to its central reality, God. Within this process:

'Human beings are God's created co-creators whose purpose is to be the agency, acting in freedom, to birth the future that is most wholesome for the nature that has birthed us.'¹⁴⁹

This proposal is not intended to be established on the basis of Christian revelation for 'even revelation is a theory to be tested.'¹⁵⁰ Rather he sees its value in the extent to which it is fruitful in opening up constructive insights rather than its being right or wrong.

Within this context human beings both act and construct narratives and symbols to interpret their action. The act includes technology and the interpretation of it includes religion. Human technology is set firmly within the realm of the evolutionary process-become-aware of itself. The technological crisis challenges human self-awareness and our efforts to discern human purpose which will be tied to the future of the planet for this

¹⁴⁴ Coulson, *Faith and Technology*, 15f.

¹⁴⁵ Coulson, *Science, Technology & the Christian*, 110.

¹⁴⁶ David J. Hawkin and Eileen Hawkin, *The Word of Science* (London: Epworth Press, 1989), 84.

¹⁴⁷ Philip Hefner, *The Human Factor* (Minneapolis: Fortress Press, 1993), 14.

¹⁴⁸ Philip Hefner, 'The Evolution of the Created Co-Creator,' in Ted Peters (ed.), *Cosmos as Creation* 1st ed. (Nashville: Abingdon, 1989), 218.

¹⁴⁹ Hefner, *The Human Factor*, 27.

¹⁵⁰ *Ibid.*, 18.

is the milieu in which human beings have evolved as the bearers of the image of God. This description carries with it both the idea of a relationship with God and also the sense of purpose which human beings have within God's ongoing creation. In dealing with the crisis of technology in this way Hefner is refusing to allow any dualism into the framework of understanding in spite of the manipulation and destruction of nature that technology exercises. Hefner also recognizes that technology shapes us as people and the way we live our lives. He is happy to adopt the expressions 'Cyborg' and 'Technosapiens' for us as human beings for whom technology is a sacred space where, 'like Jacob, we wrestle the God who comes to engage us.'¹⁵¹

Hefner's strength is that he follows Pannenberg's dictum; 'Theology has to relate to the science that presently exists rather than invent a different form of science for its own use.'¹⁵² But because he avoids using arguments and ideas from Christian revelation this is also his weakness. His Holiness Pope Benedict XVI has pointed out¹⁵³ that the modern concept of reason which underlies scientific method presupposes the mathematical structure of matter and that only the possibility of verification or falsification through experimentation can yield certainty. As a result the question of God appears unscientific or pre-scientific and there is a reduction of the radius of science and reason, a reduction which needs to be questioned. Hefner brings no challenge to science for he works on the assumption that scientific knowledge is value free and the principles on which it is gained cannot be disputed.

Hefner says that in aiming to create a framework of interpretation that provides overall orientation for human life he does not look to any concept of God to supply that framework. However by taking on board a narrow scientific approach he severely limits the kind of God that can be contemplated for Hefner's God cannot be considered to intervene in any way in creation. A consequence of this is seen in his discussion of sin where he refers to the two evolutionary strands, the genetic and the cultural, that make up a human being suffering from a 'dissonance' or not being 'fully harmonious' with the

¹⁵¹ Hefner, *Technology and Human Becoming*, 88.

¹⁵² Wolfhart Pannenberg, 'The Doctrine of Creation and Modern Science,' in Ted Peters (ed.), *Cosmos as Creation* 1st ed. (Nashville: Abingdon Press, 1989), 158.

¹⁵³ Pope Benedict XVI, *Faith, Reason and the University: Memories and Reflections* (2006 [cited 27th June 2007]); available from http://www.vatican.va/holy_father/benedict_xvi/speeches/2006/september/documents/hf_ben-xvi_spe_20060912_university-regensburg_en.html.

comment that ‘the fall and original sin may well be considered to be mythic renditions of this biologically grounded sense of discrepancy.’¹⁵⁴ There is no sense of sin including human hubris or defiance of God. Neither is there any discussion of Jesus’ resurrection which was the *raison d’être* of the Christian Church.¹⁵⁵ Eschatology is reduced to our created status being ‘thoroughly eschatological; that is, it is an *unleashing*, not a full-blown given that has simply to be reiterated and replicated throughout time.’¹⁵⁶

Hefner’s God is denied both the opportunity of personal self-revelation to the very creatures God loves and created in God’s image and the possibility of decisive action to bring about the Kingdom of God. However his concept that ‘human beings are God’s created co-creators’¹⁵⁷ and the importance he lays in technology of imagination, ‘the picturing the nonexistent into existence’¹⁵⁸, are potentially useful ideas in exploring the relationship between Theology and Technology.

2.6 Christ above culture

2.6.1 Terry Tekippe - Technological confusion needs divine wisdom

Terry Tekippe’s essay¹⁵⁹ is an exposition of Bernard Lonergan’s views on technology developed by reading across his works. Technology is a human endeavour beginning with an idea in the mind of an inventor and can be understood as a kind of meaning and knowing, classified as a form of common sense which is ‘concerned with proximate goals of doing and making.’¹⁶⁰ However technology has a theoretical side and is the child of both common sense and theoretical-scientific knowing. Through technology an artificial environment is formed and human beings change themselves. Because technology begins in the mind and expands as each new generation builds on the achievement of the previous one its growth represents a growth of intelligence. New inventions largely improve the situation, but where oversights and failures occur they are corrected by a further exercise of creative intelligence.

¹⁵⁴ Hefner, *The Human Factor*, 131f.

¹⁵⁵ C. F. D. Moule, *The Phenomenon of the New Testament* (London: SCM Press, 1967), 19f.

¹⁵⁶ Hefner, ‘The Evolution of the Created Co-Creator,’ 231.

¹⁵⁷ Hefner, *The Human Factor*, 27.

¹⁵⁸ Hefner, *Technology and Human Becoming*, 45.

¹⁵⁹ Terry Tekippe, ‘Bernard Lonergan: A Context for Technology,’ in Carl Mitcham and Jim Grote (eds.), *Theology and Technology*. (University Press of America, 1984).

¹⁶⁰ *Ibid.*, 76.

This positive view of technology does not wholly match people's experience and so Lonergan developed a second strand of thought concerning a 'flight from understanding.'¹⁶¹ For many reasons, including incompetence, stubbornness, and greed, new insights are rejected and mutilated and incoherent ideas are transmitted to the next generation. This happens because common sense, at the heart of technology, contains biases rendering it unable to grasp wider and longer term concerns. There is a fundamental bias which works against progress and as each generation builds on the errors of the previous one the situation becomes worse.

The human situation can be compared to the complex variable in mathematics which contains a real component and a surd (a multiple of $\sqrt{-1}$). The real component represents the fruit of insight and the surd the incoherencies of the flight from understanding.¹⁶² The complexities of the human situation become compounded with time with the result that human beings become profoundly disillusioned. It had been hoped that through knowledge progress would be ensured but instead there has been revealed a lack of wisdom and virtue to deal with the tremendous power now available. Because of the biases in common sense and human understanding it will not be possible for human beings to get themselves out of the situation they have created and will need a higher wisdom to overcome this long cycle of decline. This will have to be a 'super-natural' solution¹⁶³ in which human beings have faith in God who shares something of the divine higher vision and collaborates with them in providing the solution.

Tekippe's exposition of Lonergan exposes a flaw in considering technology as a form of common sense because he starts with the idea in the mind of an inventor but does not pursue the notion that technology starts with human creative imagination. As technology predates human scientific understanding it is also a mistake to see technology as the 'successful cooperation'¹⁶⁴ of science and common sense. These observations show the limitations of Lonergan's otherwise helpful account of how the human situation has declined. A side product of linking technology with common sense is that 'necessity is the mother of invention'. This is a very restrictive understanding of the scope of

¹⁶¹ Ibid., 79.

¹⁶² Ibid., 82.

¹⁶³ Ibid., 85f.

¹⁶⁴ Bernard J. F. Lonergan, *Insight: A Study of Human Understanding*, 2nd rev. ed. (London, New York: Longmans, Green, 1958), 298.

technology for the reverse is also true i.e. ‘invention is the mother of necessity’¹⁶⁵. When originally coined this referred to ‘the necessity of maintaining and expanding the apparatus,’¹⁶⁶ but the phrase may be further understood in reference to all those artifacts of technology which are, strictly speaking, not necessary but have become so because of the way we have adapted our lives around them and thereby have been changed by our own technology. This accords with Tekippe’s understanding of Lonergan that in the development of technology human beings are, in a sense, creating themselves¹⁶⁷ and their common sense view of the world (WYSIATI)¹⁶⁸.

Tekippe expounds no eschatological view in which God takes decisive future action to remedy the human situation over which Christ sits and waits for people to realize their need of divine wisdom. The process of coming to this point is presented as an intellectual one but it is not clear how any unified vision might happen given the biases present in human intelligence and the variation in human ability. A personal adaptation of a well-known saying seems apposite: ‘Those who can, do. Those who can’t, teach. Those who can’t teach contemplate the epistemological, ontological, anthropological, theological and philosophical significance of whatever it is that those who can are doing.’

2.7 Christ and culture in paradox

2.7.1 André Malet - Technology and Faith living in separate compartments

For André Malet science and technique are a ‘unifying and totalising project’¹⁶⁹ which produces a synthesis of all the different perspectives which constitute it and which extends to the totality of what is real when it is disclosed in a certain way. This unity is presumed to be there from the outset as was the expectation and intention that it would be used in ways beneficial to human beings. Malet’s focus is on modern science and technology since the seventeenth century. Scientific knowledge for Malet can be summed up by saying it is ‘the encounter of an objectifying look with an objectifiable reality’¹⁷⁰ and this even applies to the human sciences. Technique is then seen as the necessary

¹⁶⁵ Thorstein Veblen, *The Instinct of Workmanship, The Collected Works of Thorstein Veblen* (London: Routledge/Thoemmes Press, 1994), 314.

¹⁶⁶ Herbert Marcuse, ‘Social Implications of Technology,’ in David M Kaplan (ed.), *Readings in the Philosophy of Technology*. (Lanham: Rowman & Littlefield, 2004), 66f.

¹⁶⁷ Tekippe, ‘Bernard Lonergan: A Context for Technology,’ 75.

¹⁶⁸ ‘What you see is all there is’ Daniel Kahneman, *Thinking, Fast and Slow* (London: Penguin, 2011), 85-88.

¹⁶⁹ Malet, ‘The Believer in the Presence of Technique,’ 92.

¹⁷⁰ *Ibid.*, 94.

consequence of science in which being is objectified to the second degree, i.e. it is transformed into instrument. The process of technique is focussed around unlocking, transforming, storing, distributing and utilising energy. Theoretical science simply objectifies nature, technique compels it, orders it, and sets it up. Malet's use of this sort of language mirrors Heidegger as does his view of science-technique as a destiny for human beings.

For the Christian this destiny is seen as a call of God rather than carrying a negative connotation, and therefore the Christian takes it even more seriously than the non-believer because it is 'not diabolical but liberating.'¹⁷¹ There are two dangers in science and technique which are the flip-side of this liberating call addressed to human beings. The first is that human beings so focus on the process that they allow themselves to become the object of the science and technique instead of remaining the subject, and the second is that human beings take all their values from science and technique viewing them as the sole human project. The only way to steer clear of the danger that 'man can lose himself in science and technique'¹⁷² is through faith.

Christian faith is also a unifying and totalising project of an entirely different character because it is to do with the God who cannot be objectified or set-up. Faith understands the world as created by God and as having an eschatological, transformed, but unknown future as do human beings. Malet cites Luther on Romans 8.19-22 encouraging people to look to the future of creation rather than focussing solely on its present form. That future is the Kingdom of God in which objectification and setting up have no place. The science-technique project is for this life only. Here lies the paradox because faith views God and His world in this way but we need science and technique in order to exist. The paradox is resolved in part by the fact that these can be used in such a way as to fulfil the command to love your neighbour. Malet affirms that human beings are created ultimately for a Kingdom where science and technique have no place.

Malet uses the word 'technique' rather than technology which suggests he is approaching the issue with Ellul's distinctions in mind. He follows Heidegger's approach in his understanding with a clear focus on modern technique but roots it in an eschatological

¹⁷¹ Ibid., 97.

¹⁷² Ibid., 100.

context. Like Heidegger he regards this science-technique project as a destiny declaring that the reason automobiles and aeroplanes had not been invented earlier was because “the time had not yet come.”¹⁷³ Not only does he regard it as a mistake to consider that this modern technical age has come about exclusively as a product of human intelligence and determination, he disregards the human creativity that is so inextricably bound up with technology. In trying to understand technology as an object in itself he makes a partial and limited understanding of technology the whole.

It is also significant that, whereas he sets things in an eschatological context with a biblical discussion of what we know about the kingdom of God, he does not explore this in relation to the traditional Christian doctrines of creation and the fall. This failure, coupled with the way he understands technique, results in his verdict that when the Kingdom of God comes there will be no place for the objectifying and setting-up behaviour that technology involves. Technology, therefore, has only a temporary significance in the purposes of God so that human beings can survive until the kingdom of God comes about. A broader understanding of technology including the human aspects of creativity, finitude, and sin would allow for the possibility of the technological enterprise, ‘stimulated by imaginative and not material motives,’¹⁷⁴ finding a place within the wider and eternal purposes of God.

2.8 Christ the transformer of culture

2.8.1 Egbert Schuurman - Technology in need of sanctified motivation

Schuurman seeks to counter the view that the human being is not the ‘master of technology, but its slave and its victim’¹⁷⁵ by expounding a Biblical view of history which yields a fourfold understanding of the roots of technology, its problems and the solution. The first biblical given is the cultural mandate in the opening chapters of Genesis where Adam, on behalf of the human race, made in the image of God, is called to build and keep God’s creation so that it will unfold as God intended. In this way human creative work leads to the praise of God. The second is the fall of human beings from community with God seeking instead the role of God the creator. Progress is then distorted and history becomes a way of death with alienation from God leading to

¹⁷³ Ibid., 97.

¹⁷⁴ Pacey, *The Maze of Ingenuity*, 86.

¹⁷⁵ Schuurman, 'A Christian Philosophical Perspective on Technology,' 108.

alienation from the creation. The third given is God's initiative to provide redemption in Jesus Christ who, as the second Adam, has provided for the reconciliation of all things so that in him 'the redemption and the fulfilment of creation are assured.'¹⁷⁶ The final given is of on-going disobedience to the Kingdom of God and attempts to secularise it into a human kingdom. Aided by modern technology the characteristics of the fall are intensified in an expansion of chaotic, destructive and demonic power which may appear to be overwhelming but it will be God and His Kingdom that have the last word.

Schuurman perceives that the Reformation, which led people to accept their calling to develop the creation, became dominated by Renaissance humanism following the 18th century enlightenment. In the process Christian eschatology was transmuted into the expectation of technological salvation through the building of a paradise on earth. Even though it was destruction that came rather than salvation people persist in believing that the solutions to the problems resulting from technological development lie in further such advances. The temptation for some Christians to view this resulting cultural situation as fully demonic is mistaken for it ignores the building of Noah's ark, a sign of salvation, and the fact that it was by God's Spirit that Bezalel and Oholiab were inspired to ply their technical craft in the construction of the tabernacle in the desert.

Even though modern technology appears to be beyond control, 'technology is not bad in itself'¹⁷⁷ and whether we have to deal with its blessings or its curse will depend on the human motivation behind its development. Whilst the predominant motivations have been economic power, faith in science and the pursuit of its application, and the imperative to technological perfection, ultimately it is the will to power which motivates modern technology and changing the direction of modern culture requires a change in this basic motive. The proper motivation required for technology is based on the recognition that we are created in the image of God with all the responsibilities, expressed as love of God and love of one's neighbour, that come with such a creation. With this motivation technology ceases to operate solely in terms of its own inner laws and dynamics in a self-sufficient way. Engineers also need humility to prevent them over-reaching themselves and to permit scrutiny and critique of their work.

¹⁷⁶ Ibid., 110.

¹⁷⁷ Ibid., 114.

For Schuurman technology is a pilgrimage of obedience, a mandated way to greater insight into the meaning of creation as the Kingdom of God. In this there are two ways in which Christ is the transformer of technology. The first is through the action of technologists motivated by the totality of God's call to people to serve in this world and the second is through the future eschatological fulfilment of creation. 'In Jesus Christ the Kingdom of God has come and is coming.'¹⁷⁸

Schuurman's more Biblical approach deliberately looks beyond viewing technology as a thing in itself and perceives it as a proper human creative activity. It is human sin which distorts the motivation behind the development of technology. However linking the problems created by technology purely to sin is mistaken for it oversimplifies matters. As God's creatures human beings are finite in their being, knowledge, and understanding. At the start of any project with an element of novelty a designer cannot know all the consequences of the project. There is a process of learning involved in designing, developing and using a technological product, and it may take years for a problem to become apparent. An example of this is global warming which is increasingly understood as atmospheric science develops. In other words not only is there sin involved in technological development but there is risk attached inherently to the process even if there were no sin.

2.9 Conclusions.

This review of the relationship between theology and technology using Niebuhr's categories has revealed a bewildering array of potential viewpoints. In his original writing Niebuhr clearly favours the 'Christ the transformer of culture' option. His position has been attacked, 'few books have been a greater hindrance to an accurate assessment of our situation than *Christ and Culture*,'¹⁷⁹ because it did not provide any means of discriminating between what is good or bad in culture. Hauerwas and Willimon claim Niebuhr's position, that the church through its good works in cooperation with the state is bringing about Christ's transformation of culture, fails to notice that the church has been tamed by the world and lost its divine agenda. They propose that the church should become 'the community of the cross' and move from the 'acceptance of the

¹⁷⁸ Ibid., 110.

¹⁷⁹ Stanley Hauerwas and William H. Willimon, *Resident Aliens* (Nashville: Abingdon Press, 1989), 40.

culture with a few qualifications, to rejection of the culture with a few exceptions.’¹⁸⁰ However this ‘Christ against culture’ position fails to acknowledge the way in which Christians and the church are involved in an immersive interconnected technological culture. In preferring a ‘community of the cross’ rather than a ‘community of the resurrection’ the significance of the created order and human creativity within it is obscured. This is because the resurrection of Jesus Christ is the promise and guarantee of redemption and renewal for the whole of creation.¹⁸¹

Mitcham also rejects Niebuhr’s position, opting for a combination of ‘Christ against culture’ and ‘Christ and culture in paradox’¹⁸² so that some critique of technology may be mounted even though he acknowledges serious questions can be raised against both positions. There is a basic assumption here that an oppositional stance to technology is inherent in Christian theology. Such an assumption may be claimed to follow from the biblical insight that ‘God is very slow and *inefficient* in his dealings with the human race’¹⁸³ or from a Christian tradition that ‘ultimately non-action will prevail over action.’¹⁸⁴ Such a reading of scripture and tradition is however not value free but is governed by our modern situation in which technology appears to be ubiquitous, incomprehensible and beyond our control. In other words there is a failure to understand all the elements that make up modern technology. The resulting ‘anti-science metaphysics’ and ‘demonising of technology’¹⁸⁵ must be rejected and a deeper understanding sought.

In developing his combined position Mitcham shows the problems attached to setting up these viewpoints which may be illustrated from the writings of various people at one time or another, but which may not be held unequivocally by anyone. This example illustrates the fact that ‘the production of universal, totalizing theory is a major mistake that misses

¹⁸⁰ Ibid., 47.

¹⁸¹ Wright, *Surprised by Hope*, 119.

¹⁸² Carl Mitcham, ‘Technology as a Theological Problem in the Christian Tradition,’ in Carl Mitcham and Jim Grote (eds.), *Theology and Technology*. (University Press of America, 1984).

¹⁸³ Charles Mabee, ‘Biblical Hermeneutics and the Critique of Technology,’ in Carl Mitcham and Jim Grote (eds.), *Theology and Technology*. (University Press of America, 1984), 168.

¹⁸⁴ P.Hans Sun, ‘Notes on How to Begin to Think About Technology in a Theological Way,’ in Carl Mitcham and Jim Grote (eds.), *Theology and Technology*. (University Press of America, 1984), 191.

¹⁸⁵ Donna J. Haraway, ‘A Cyborg Manifesto,’ in David M Kaplan (ed.), *Readings in the Philosophy of Technology*. (Lanham: Rowman & Littlefield, 2004), 175.

most of reality.’¹⁸⁶ Niebuhr himself was aware of this problem when he said of Tertullian, ‘the epitome of the ‘Christ-against-culture’ position’, that ‘he sounds both more radical and more consistent than he really was.’¹⁸⁷ An underlying problem here is the tendency to objectify technology and treat it independently of its origin as a human activity. In later work on the relationship between engineering and philosophy Mitcham recognised the need to understand ‘engineering-technological experience, to some extent even in its own terms’ in the process of exploring ‘the philosophical richness of technology.’¹⁸⁸

For these reasons, instead of attempting to justify a particular understanding of the relationship between objectified forms of Theology and Technology, it is more appropriate at this stage to highlight two particular questions that the foregoing exploration has raised, viz. what is the relationship between human technical achievements and the purposes of God, and from where does the ability to achieve these things come? Put another way we may ask whether the creativity that is evidenced in the development of human technology is intended by God even though it is misused, and are the products of that technology simply for the world as we know it or do they and human creativity itself ultimately have some place within God’s kingdom? The following chapters will explore human creativity including the way it is evidenced in technology. The roots, scientific and theological, of this creativity will be examined as well as its negative effects in the world. This exploration will lead to an appraisal of where human technology belongs within the purposes of God.

A final observation to be made here is related to Ellul’s proposal that humans need to develop a new ethic through which to reassert mastery over technology. Richard Dreyfus takes a lead from Heidegger in seeking a free relation to technology and suggests that the music of the Beatles and Bob Dylan ‘was the articulation of a new understanding of what really mattered’¹⁸⁹ and ventures the suggestion that the Woodstock Music Festival might have enabled a new understanding had enough people really cared. However the concerns of that generation were not deep enough to counter technology and sustain an

¹⁸⁶ Ibid.

¹⁸⁷ Niebuhr, *Christ and Culture*, 67.

¹⁸⁸ Mitcham, *Thinking through Technology*, 268.

¹⁸⁹ Hubert Dreyfus, ‘Heidegger on Gaining a Free Relation to Technology,’ in David M Kaplan (ed.), *Readings in the Philosophy of Technology*. (Lanham: Rowman and Littlefield, 2004), 60.

alternative culture. The suggestion is that the creation should be celebrated rather than exploited providing a different motivation for technological development. A related proposal is that of ‘Communities of Celebration’ which ‘overlap and interconnect’¹⁹⁰ made by Albert Borgman in response to the individualistic and technologically driven culture we inhabit. It is not the purpose of this thesis to examine or develop such an ethic, others will do that far more effectively, but in exploring the theology of technology I hope to uncover the foundations on which such an ethic may be built.

¹⁹⁰ Borgmann, *Power Failure*, 58.

Chapter 3

Creativity

In the previous chapter the key question raised was that of the relationship between human creativity and God's creation. The purpose of this chapter is to consider some aspects of creativity from different viewpoints in order to illuminate what creativity is and who is, or can be, creative. An appropriate starting point is this thesis itself. Will it be a creation, or an invention, or perhaps even an absurdity conveying no meaning at all? How long would it take one hundred monkeys randomly pressing the keyboard keys of one hundred computers to generate this document? The original conundrum related to typewriters and the works of Shakespeare, but technology has moved on. The practical answer to the question was that they would never do it because it would not be possible to keep them 'on task' long enough. But the point is not easily disposed of for the question can be reposed in terms of the printout from a computer programmed to operate in a random fashion. Just one would be enough. Can a sufficiently long random process end up producing something creative? Evolution may be mistakenly regarded as a creative random process but only the novelty which fits well into the environment actually flourishes because of the 'non-randomness of selection.'¹⁹¹ We shall return to this model of mutation and environmental selection as way of understanding the creative process of technology later in this thesis.

My feelings about intentionality and authorship suggest a negative answer to the question as to whether long random processes can be creative. How would we know which parts appear to have a human author without reading all the way through and separating out those parts which fulfil appropriate criteria? If Margaret Boden is correct in answering her 'third Lovelace question' affirmatively¹⁹², i.e. a computer could appear to recognize creativity, then software, more subtle than that which puts red and green lines under this text, could be developed to recognise meaningful writing automatically¹⁹³. This highlights the theoretical post-modern situation where the responsibility for creativity

¹⁹¹ Richard Dawkins, *Climbing Mount Improbable* (London: Penguin, 1997), 70.

¹⁹² Margaret A. Boden, *The Creative Mind*, 2nd ed. (London: Routledge, 2004), 16-20.

¹⁹³ Margaret Boden devised 4 questions relating to computers and creativity and named them after Lady Ada Lovelace a close friend of Charles Babbage the inventor of the 'Analytical Engine'. See *ibid.*, 16f.

rests with the reader rather than the author. In practice universities and schools have rejected this approach when it comes to exams and dissertations. Otherwise someone hoping to achieve a particular qualification would be entirely at the mercy of the creative ability of the examiner.

The questions about computers and creativity have been pushed further by asking whether automatic or mechanistic activity can achieve or fulfil the purposes of God. At the end of Arthur C. Clarke's short story 'The Nine Billion Names of God' the universe comes to an end as the task of listing all the divine names is completed by an automatic sequence computer. This machine was being employed by some Tibetan monks to speed up their handwritten production of the list believing that when the job is finished God's purposes for the world and therefore the world itself will come to an end, 'only it's nothing as trivial as *that*.'¹⁹⁴ One response to the story is to wonder what sort of egocentric God would want to create a world simply to have a list of all the divine names? But in the apparent absurdity of the notion Clarke is putting his finger on the question of how we can know the purposes of God and whether they could seem rational or probable to us. From a Christian point of view any discussion of human creativity has to be in the context of God's creativity.

3.1 Language and Communication

It is also true that every human creative action takes place in a specific context with its own history. When writing a paper an author will compose it by putting together various words of different parts of speech in a combinatorial manner using the normal rules of syntax and grammar such as she knows them. These rules are part of the 'tacit'¹⁹⁵ element of a person's upbringing before ever going to school and learning such things more formally. Within the English language such rules have a history and have developed in specific contexts. Is it possible to be creative whilst bound by an existing tradition? Of course the tradition changes and rules themselves alter. The grammatically proper expression 'would have' is transmuted via 'would've' to 'would of'. This change begins perhaps in careless speech but ends up in the written word penned by those now ignorant or forgetful of what some would regard as the proper, established rules. The

¹⁹⁴ Arthur C. Clarke, 'The Nine Billion Names of God,' *The Collected Stories*. (London: Gollanz, 2000), 420.

¹⁹⁵ Polanyi, *Personal Knowledge*, 69-131.

phenomenon of ‘texting’ causes concerns to those wishing to maintain what are regarded as standards of spelling and grammar. They question the possibility of precise communication of ideas without agreed rules. However, these rules have changed over the centuries and it is salutary to remember that the English language did not exist two thousand years ago. Indeed if speakers of English separated by a thousand years were to meet through some freak temporal conditions they ‘would have difficulty understanding each other’¹⁹⁶ because of the changes that have occurred over that time. The language has developed over time as its speakers and writers have sought to respond to new situations. The real problem these days is the speed at which things change¹⁹⁷ so that an older generation struggles to keep up with what the youngsters are doing whilst sensing they are not in control and may have little say in the way culture develops.

In areas where ‘precise communication’ is needed, such as science and technology, special languages, verbal as well as those of mathematics and technical drawing, have been created. In engineering drawing there is a need for accuracy in communications between designers and manufacturers. National standards, e.g. BS 308 in Great Britain, have been developed and then superseded by publications from the International Standards Organization so that the ‘language of Engineering Drawing’¹⁹⁸ can be tightly regulated. Fig.3.1 (p.61) is a simple example of technical drawing¹⁹⁹ designed as a student exercise.

A key piece of information is the symbol  in the top left corner. This is a hermeneutical key which tells the reader how to read the drawing by indicating that it is drawn in ‘third angle projection’ thus specifying how the various views of the object relate to each other.

¹⁹⁶ David W. Anthony, *The Horse the Wheel and Language* (Princeton, New Jersey: Princeton University Press, 2007), 22.

¹⁹⁷ Coulson, *Science, Technology & the Christian*, 27.

¹⁹⁸ Brian Griffiths, *Engineering Drawing for Manufacture* (London: Kogan Page Science, 2006), 3.

¹⁹⁹ A Yarwood, *Graphical Communication: Book 1*, 2nd ed. (Walton-on-Thames: Thomas Nelson and Sons, 1984), 79.

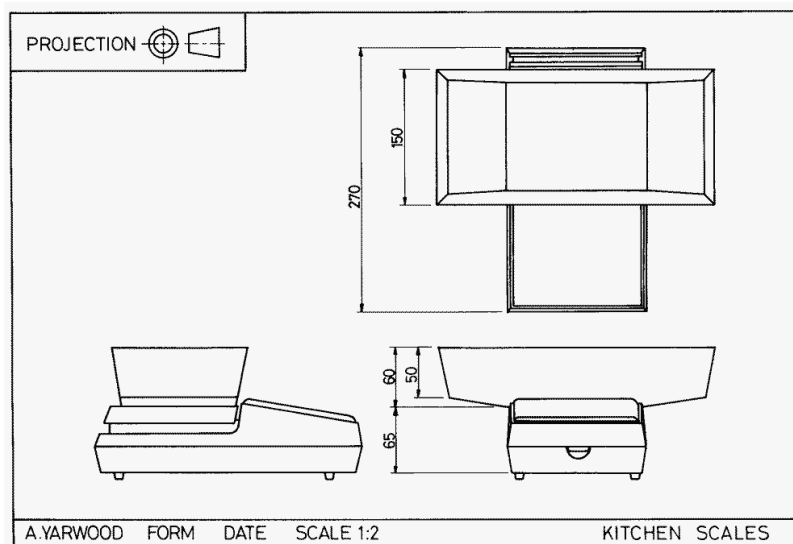

Fig.3.1 Student Technical Drawing Exercise.
From Yarwood 'Graphical Communication: Book 1' p.79

In the history of mathematics there has been a development of a symbolic language which at first was accompanied by argument and explanation written in the ordinary way of verbal expression, but which then in the seventeenth century 'displaced verbal writing to a much greater extent than formerly.'²⁰⁰ We might also note that whilst it is possible to study mathematics as a language as has been done by Munroe²⁰¹ and Rotman²⁰² there has developed 'mathematical linguistics' which is a 'non-calculative discipline primarily concerned with the formal modelling of language'²⁰³ which uses set theory and the formal logic of mathematics in the study of language.

Mathematics is particularly the language of physics but in chemistry the need has presented itself for some form of graphical modelling and various methods have been developed.²⁰⁴ Fig.3.2 (p.62) illustrates some of them with regard to the structure of Ethane.²⁰⁵

²⁰⁰ Florian Cajori, *A History of Mathematical Notations*, vol. 1 (Chicago: Open Court Publishing Company, 1928), 426.

²⁰¹ M. Evans Munroe, *The Language of Mathematics* (Ann Arbor: University of Michigan Press, 1963).

²⁰² Brian Rotman, *Mathematics as Sign*, ed. Timothy Lenoir and Hans Ulrich Gumbrecht, *Writing Science* (Stanford University Press, 2000).

²⁰³ Maurice V. Aldridge, *The Elements of Mathematical Semantics* (New York: Mouton de Gruyter, 1992), 1.

²⁰⁴ Ursula Klein, ed., *Tools and Modes of Representation in the Laboratory Sciences*, vol. 222, *Boston Studies in the Philosophy of Science* (Dordrecht: Kluwer Academic Publishers, 2001).

²⁰⁵ John McMurry, *Organic Chemistry*, 4th ed. (Pacific Grove: Brooks/Cole 1996), 20f.

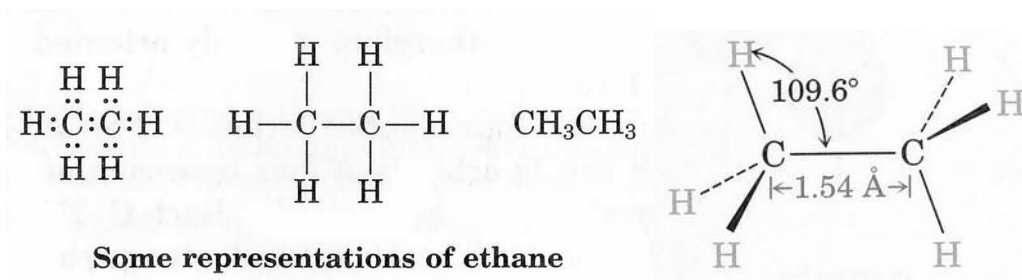

Fig.3.2 From John McMurray 'Organic Chemistry' p.20f

On the left is a Lewis structure with a Kekulé diagram to its right followed by a Berzelian formula and then a 'wedge and dash' model which one of several solutions to the problem of how to convey the three-dimensional structure of molecules via two dimensional media. With regard to the Berzelian formulae Ursula Klein has argued that the invention of such 'paper tools' was not simply providing a method of depicting an understanding of molecular structure but actually enabled the creative development of organic chemistry in the early nineteenth century.²⁰⁶ This language was an aid to imagination.

3.2 Language and creativity

In everyday language there is a tension that opens the way to creativity. The elements of language need to appear to have stable meanings for communication to take place, but so that adaptations to new situations can be made, there must be a 'certain looseness of meaning.'²⁰⁷ It is also possible to 'push' grammar by the use of constructions from another language and culture to make a connection or emphasise a point. A Germanic construction such as 'the, on the mat sitting, cat' somehow accents the relationship between the cat and the mat, when it is used in English, which is not quite there in 'the cat sat on the mat'. Whether this would be creation or invention might well depend on the subtlety of operation and the openness of the reader to accept the point. It can be accepted that 'the audience and the viewer play key roles in the creative process'²⁰⁸ without denying the role of the author. The language itself, whether spoken or written is always open to the possibilities of change and development. This means that the

²⁰⁶ Ursula Klein, *Experiments, Models, Paper Tools: Cultures of Organic Chemistry in the Nineteenth Century, Writing Science* (Stanford: Stanford University Press, 2003), esp. ch.9 "Paper Tools".

²⁰⁷ Charles Rosen, *Schoenberg* (London: Marion Boyars, 1976), 27.

²⁰⁸ R. Keith Sawyer, *Explaining Creativity. The Science of Human Innovation*, 1st ed. (New York: Oxford University Press, 2006), 259.

historical and cultural baggage that it brings to a certain point is no automatic barrier to creativity for the aspiring author.

Words themselves come with established meanings. Some have a long history, coming out of an earlier tongue which served as a tributary to the English language. Others may have been imported to serve a purpose where existing words were not up to the task of conveying a precise meaning. An author writing a novel which included descriptions of snowfall might try to achieve greater descriptive precision by importing an Inuit word from their richer vocabulary of words for snow. This ruse would generally fail unless readers were familiar with that language or prepared to do the necessary work to understand the meaning more clearly. The word 'poiesis' has often been used since the middle of the twentieth century when discussion has been of artistic creativity in literature and fine art and is well understood by many readers in those areas. Newcomers have to reach for the dictionary and psychologists run the risk of misinterpreting it in the sense of a schizophrenic coining of 'neologisms'. And that is another imported word, introduced from French, but with even deeper roots, in the later eighteenth and early nineteenth centuries, which carries subtle shades of meaning ranging from 'new words' to 'new logic' according to context.

Using a pre-existing language with its set forms does not itself rule out creativity, but neither does it guarantee its occurrence. Steiner laments his own lack of 'the necessary originality'²⁰⁹ when faced with Walter Benjamin's dream of publishing a book composed entirely of quotations. The interplay of words such as 'creation' and 'invention' also intrigue him as he questions why our language baulks at saying 'God invented the universe'. 'Invention' appears to carry the possibility of deceit. Mendacious stories are made up, invented. But deceit is no necessary part of the meaning of invention which may well speak of creativity. Thomas Hughes uses the phrase 'American technological creativity'²¹⁰ to refer to what he then goes on to describe as the inventiveness of individual Americans.

So far the focus has been on the use of words as the focus of creative activity. The words 'poem', 'poet' and 'poetry' derive their origin from the greek '*poiein*', to make, to create,

²⁰⁹ George Steiner, *Grammars of Creation* (London: Faber and Faber, 2001), 13.

²¹⁰ Thomas P. Hughes, *American Genesis*, 2nd ed. (Chicago: University of Chicago Press, 2004), 2.

and this is the root of the imported word '*poiesis*', a creative production, referred to above. There is then the possibility of the creative use of language, even with its givenness, for at any point in time language will only partially cover human experience causing people to push the boundaries of the use of words and develop new words. Examples of this can be seen in Heidegger's use of existing and coining of new words.²¹¹ There is openness to language which can be seen in 'its capacity to be developed in novel and unexpected ways.'²¹² Art and music were originally seen as crafts, '*techné*', but later on their practitioners, in developing their skills and practices, also laid claim to novelty in their work so that these days to be described as artistic is to be regarded as creative. We must, therefore, widen the horizon of this analysis to include creativity in other aspects of our culture.

3.3 Creative people are not unique

The title pages of 'Grammars of Creation' include the statement: 'The right of George Steiner to be identified as author of this work has been asserted in accordance with section 77 of the Copyright, Designs and Patents Act 1988.' The idea of a single author seems to be central to creativity. At first within the Christian understanding God alone was creative and then in the early fifteen century came a new and exciting idea 'that men could be truly creative'²¹³ but this possibility was restricted to rare individuals. Psychologists focus on the activities of individuals. In an engineering project team there is space for only one truly creative person according to Tom Hanson²¹⁴. George Steiner struggles with the naming of multiple authors on scientific research reports and Stanley Jaki²¹⁵ limits his list of creative scientists to less than twelve. Clearly, traditionally, creativity has been thought of as the characteristic of certain individuals. I would suggest that this natural focus on particular people who have shown great originality in a particular field of human endeavour obscures the wider situation. Keith Sawyer exposes the falsehood of 'those creativity myths that focus on the individual and neglect the

²¹¹ e.g. Heidegger, 'The Question Concerning Technology,' 9-12 notes 7-12.

²¹² David Brown, *Tradition and Imagination* (Oxford: Oxford University Press, 1999), 44.

²¹³ Pacey, *The Maze of Ingenuity*, 88.

²¹⁴ Hanson, *Engineering Creativity*, 42.

²¹⁵ Stanley L. Jaki, 'Theological Aspects of Creative Science,' in Richard W.A. McKinney (ed.), *Creation Christ and Culture*. (Edinburgh: T. & T. Clark Ltd, 1976), 153.

social and cultural context'²¹⁶ and Margaret Boden defends the notion of 'Everyman' creativity.²¹⁷

Hans Rookmaaker's view of creativity is what we might call a democratic one. 'Creativity is nothing special' is one of his section headings²¹⁸ and he means by this that creativity is not limited to certain specialised activities such as the production of works of art and to certain notable people such as composers of music. He is quite clear that creativity is part of everyone's work whether we are homemakers, engineers, scientists. This view appears quite contrary to that of Stanley Jaki who is concerned that creativity is an overused word. He reminds us that there was a time when the only proper subject of the verb 'to create' was God and that 'in the Old Testament the word *bara*' was reserved to an action which only God could perform'.²¹⁹ The current emphasis on everybody being creative is an abuse of the word in his view. However not only is general creativity recognised there is a belief that it needs to be fostered. In education one of the key purposes of our schools is to help develop the pupils' individual creativity. There are many books promoting techniques for improving one's creativity,²²⁰ but are they working with the same definition of the word? David Bohm denies the possibility of such techniques succeeding, 'certain kinds of things can be achieved by technique and formulae, originality and creativity are not among these'²²¹, but the thrust of Sawyer's work is to indicate how creativity can be developed and improved whilst including 'everyone is creative' in his list of false creativity myths.²²²

The reason for this extreme divergence of viewpoint within the Christian community between Jaki and Rookmaaker is that at the point of writing these two authors had very different purposes in mind. Rookmaaker is concerned that especially creative people are not revered in such a way that others with lesser gifts are put off from using them for the benefit of all. He is emphasising the cultural mandate of the first chapters of Genesis in

²¹⁶ Sawyer, *Explaining Creativity. The Science of Human Innovation*, 30.

²¹⁷ Boden, *The Creative Mind*, 256ff.

²¹⁸ Hans R. Rookmaaker, 'The Creative Gift,' in Marlene Hengelaar-Rookmaaker (ed.), *The Creative Gift, Durer, Dada and Desolation Row, The Complete Works of Hans Rookmaaker*. (Carlisle: Piquant, 2002), 179.

²¹⁹ Jaki, 'Theological Aspects of Creative Science,' 152.

²²⁰ E.g. Sawyer, *Explaining Creativity. The Science of Human Innovation*, Mihaly Csikszentmihalyi, *Creativity* (New York: HarperCollins, 1997).

²²¹ David Bohm, 'On Creativity,' in Lee Nichol (ed.), *On Creativity* 1st ed. (London: Routledge, 1998; reprint, 2004), 26.

²²² Sawyer, *Explaining Creativity. The Science of Human Innovation*, 22.

the broadest sense. Jaki has a more limited point in view. He does not want to rule out creativity as a human activity but he does want to limit the use of the word to a few truly great people. In terms of the development of science he produces a list of only eleven truly creative scientists²²³ in the whole course of known human history. The list includes Copernicus, Newton, Planck and Einstein. He notes that physicists in the 18th and 19th centuries saw themselves as ‘surveyors of a new continent’²²⁴ discovered by Newton.

What Jaki is saying is that the truly creative scientists produce ideas that are novel and not simply developments of an existing way of understanding the world. So he is limiting the use of the word creative to what is novel for the whole of humanity. His purpose is in identifying that these truly great creative scientists have a particular outlook on and understanding of the world around them. They work on the assumption that there is an objective, ordered, rational reality undergirding our experience of it. This understanding is behind Tom Torrance’s note that Einstein’s famous statement, ‘God does not play dice’ did not represent a lapse into determinism, rather it expressed his discontent with a statistical approach to quantum theory, as in the Copenhagen formulation, because for him the basic function of science is to ‘lay bare the structures of reality as far as that is possible’.²²⁵ Jaki notes the stillbirth of science in ancient cultures that were ‘steeped in paganism’ in contrast to its ‘only viable birth’ that took place within a ‘distinctly Christian cultural matrix.’²²⁶ Jaki’s view is that the contingent and rational understanding of the world which underlies science stems from the Christian belief in God as creator. It is this understanding that encourages scientists to seek to discover ‘the structures of reality.’

Jaki is defining creativity in science as the production of a completely new and deeper insight into the workings of the universe that cannot simply be predicted from existing knowledge. He sees the great scientists making these kinds of breakthroughs and being followed by those ‘lesser’ scientists who survey and chart the newly discovered territory. He does not wish to allow that this latter activity is also creative to some extent and relies on the use of imagination. Rookmaaker understands creativity as the development and use of personal gifts within the whole of life. This living is based in openness to the

²²³ Jaki, 'Theological Aspects of Creative Science,' 153.

²²⁴ *Ibid.*, 156.

²²⁵ Thomas F. Torrance, *Divine and Contingent Order*, 1st ed. (Oxford: Oxford University Press, 1981), 13.

²²⁶ Jaki, 'Theological Aspects of Creative Science,' 165.

world, including its people, and not limited by arbitrary precedents on how the world and its relationships are to be understood and lived out. Thinking specifically of Christian freedom as a model for all freedom he says it is not 'freedom *from* something, but freedom *to do* something. It means openness, freedom of movement, exploration and mental adventure.'²²⁷

Rookmaaker's emphasis on freedom finds an echo in Koestler's theory of creativity as a 'bisociative act' which 'connects previously unconnected matrices of experience.'²²⁸ He begins his study of the subject with an examination of humour and thinks of laughter as ringing 'the bell of man's departure from the rails of instinct; it signals his rebellion against the singlemindedness of his biological urges, his refusal to remain a creature of habit, governed by a single set of 'rules of the game'.'²²⁹

The views of Jaki and Rookmaaker are not mutually exclusive. They appear to be so because of the different purposes of the writers and the definitions they employ. It is appropriate to see them as complementary. Inventiveness and creativity are all part of a single continuum and people fit into it in different places according to their personal abilities.

This continuum can be further illustrated from the works of David Bohm. In his thoughts of scientific creativity he speaks of '*discovering* oneness and totality in nature'²³⁰ and in that he is in harmony with Jaki. However in illustrating his view more broadly he uses the illustration of a child learning, 'whose interest in what is being done is wholehearted and total.... is always open to learning what is new, to perceiving new differences and new similarities, leading to new orders and structures.'²³¹ In focussing on a child learning, say, to walk, Bohm crosses over into Rookmaaker's territory and opens it up to a further question of creativity. If creativity is the achievement of something new, is that necessary newness for the whole of humanity or can it still be valid creativity if the newness is for one person or a particular group of people. When the penny drops does this mark creativity only the first time ever it drops or also when it drops in a different

²²⁷ Rookmaaker, 'The Creative Gift,' 178.

²²⁸ Arthur Koestler, *The Act of Creation*, Picador ed. (London: Pan Books, 1975), 45.

²²⁹ *Ibid.*, 63.

²³⁰ Bohm, 'On Creativity,' 2.

²³¹ *Ibid.*, 17.

context? Margaret Boden develops the idea of two senses of ‘creative’: ‘*P-creative*’ and ‘*H-creative*’²³². The former, psychological, sense refers to ideas which are new or surprising to the individual mind and the latter to ideas that are novel with respect to ‘*the whole of human history*’. The former sense underlies the possibility of the latter but that does not guarantee the significance of every idea.

It is this ‘*P-creativity*’ which is Boden’s ‘Everyman’ creativity. It underlies the human ability to create an imaginative mental model of the world which relates very well to reality. In personal creativity the key mechanism ‘is the capacity to produce an original interpretation of experience’²³³ and everyone has this capacity. It is most active in children especially as it is related to the epigenetic growth of the brain which provides the physical base for mental activity. The significance of this understanding of creativity is the expectation that it will be found in all areas of human endeavour and not just in the artistic ones. Even in an area often thought to be rule based and therefore not creative ‘there is much more room for creativity in everyday moral judgement than most psychological theories of morality have assumed.’²³⁴

3.4 Creativity is not the preserve of the ‘Arts’

Steiner doubts the validity of scientific creativity because he perceives the advance of science as something inevitable in that if a particular person or team had not made the discovery, someone else would have done, perhaps at about the same time. ‘The invention of calculus, of the theory of natural selection or of the structure of DNA are famous cases in point’ however ‘The work of art, of poetics, carries within it, as it were, the scandal of its hazard, the perception of its ontological caprice.’²³⁵ We shall see later that this does not do justice to the process of scientific discovery let alone the development of all the gadgets and gizmos of technology. Was the invention of the iPod inevitable, and if so does that mean that no creative kudos adheres to the inventor?

²³² Boden, *The Creative Mind*, 43.

²³³ Mark A Runco, ‘Reasoning and Personal Creativity,’ in James C. Kaufman and John Baer (eds.), *Creativity and Reason in Cognitive Development*. (New York: Cambridge University Press, 2006), 101.

²³⁴ David A. Pizarro, Brian Detweiler-Bedel, and Paul Bloom, ‘The Creativity of Everyday Moral Reasoning,’ in James C. Kaufman and John Baer (eds.), *Creativity and Reason in Cognitive Development*. (New York: Cambridge University Press, 2006), 81.

²³⁵ Steiner, *Grammars of Creation*, 24.

The question can be turned back on artistic creativity. An individual piece of music is contingent and might not have seen the light of day, but what of the milieu in which it was composed? When Charles Rosen wrote ‘The resistance to Schoenberg's radical break with the nineteenth-century tradition was as inevitable as the break itself’²³⁶ he was not playing down the magnitude of that resistance but rather emphasising the inevitability of the break with the current traditions of musical composition. These traditions had become increasingly under strain as successive composers had pushed at the boundaries of acceptability and if Schoenberg hadn’t made the break into a different conceptual space within which to do musical composition someone else would have made it. ‘It might not have been Schoenberg, and it might not have occurred in 1908. But it had to happen, sometime’²³⁷ and what has happened is the opening up of a new intellectual territory which can then be explored by others in a similar way to the opening up of new territory in science described earlier. Viewed in this light it is clear that artistic creativity and scientific discovery are not as far apart as Steiner senses. Once established the new intellectual territory becomes the tacit intellectual territory so that explorers in it, taking it for granted, may forget the creativity that was involved in opening it up. Context is important for the appreciation of creativity.

Steiner concedes that artistic and literary work is created through dialogue with the work of others. It is not possible for the artist to create in a cultural vacuum. There are the mental conversations that are held incessantly with one’s predecessors and peers. Other people may have had similar mental conversations to the ones I have held and produced the same thoughts that I have put to paper without having had the opportunity to go public. Many insights and original thoughts may have perished unvoiced because their author has not realised their significance or thought they were a ‘cartload of dung’ as did Kepler when he first conceived of planetary elliptical orbits²³⁸. Daydreaming, although an imaginative activity, is generally not considered creative as there is no product in the public domain. Creativity may be forgotten or even denied if the context in which it originally occurred is lost. A work of art which was created and honoured in a particular context may even lose its meaning if the context is lost.

²³⁶ Rosen, *Schoenberg*, 16.

²³⁷ Boden, *The Creative Mind*, 73.

²³⁸ *Ibid.*, 43.

As an undergraduate engineer at Bristol University I attended seminars on English because the powers-that-be were concerned about the poor communication skills of engineers. Alan Reynolds led the sessions by getting us to read various pieces of poetry and prose and then decide whether they were good English or not. We read the passage from Ecclesiastes chapter 12 beginning ‘Remember thou thy creator in the days of thy youth....’ from the King James Version of the Bible. To Mr Reynolds’ horror we pronounced it poor English because we did not understand it. A brief exposition followed that was sheer delight as he unfolded the mysteries of the imagery of old age in the passage. Did we now think it was good English? ‘No,’ we continued to assert, because he had had to explain it to us. The context was lost. In a similar way the creativity of Carravaggio’s ‘The Sick Bacchus’, although ‘an outlandish challenge to the conventions’²³⁹ of its day, is lost on me unless I am instructed by an expert such as Simon Schama.

These examples suggest that, even if George Steiner’s intuition that every work of poiesis is a protest at mortality, an attempt at immortality is correct, the attempt is doomed to failure as ‘time, like an ever rolling stream, bears all its sons away’. Only the ‘cognoscenti’ understand the creativity of the past and, with the expansion and fragmentation of knowledge, that of the present. How readily can anyone assess the creative significance of work in a field not related to their own speciality?

Steiner’s intuition of this protest in works of art and literature is suggestive of technological acts such as the way Cain built the city of Enoch (Gen. 4.10-17) and the descendants of Noah built the Tower of Babel (Gen. 11.1-4). In both cases there is an act of defiance against God. Cain, sentenced to being a restless wanderer on the earth after he murdered Abel, builds a fixed place of security despite God’s protection of his life. Noah’s descendants, given the command to fill the earth, become fearful that they will be scattered over the face of the earth as they grow in number so they start to build a city and a strong tower as a focal point for themselves. In the protest, along with that ‘miniaturization, a charged particle, as it were,’²⁴⁰ of the original creation, may be perceived human hubris, a rebellion against God’s verdict upon the human race. Alternatively in the teamwork, so necessary apparently for the advance of science and

²³⁹ Simon Schama, *Power of Art*, 1st ed. (London: BBC Books, 2006), 27.

²⁴⁰ Steiner, *Grammars of Creation*, 255.

technology, may be perceived an echo of God's desire for the human race expressed in the image of the 'Body of Christ' used by St Paul as a description of the Church and its internal distribution of spiritual gifts. But, so that a wedge may not be driven between the arts and the sciences we note that artists would use their apprentices to complete works that they had started, and that there certainly have been the individual scientists of great creativity such as on Jaki's list.

Creativity, then, is a gift which is given to humanity in general even though it is more developed in some people than others. Its range of operation is not restricted to the arts but to the whole of life including the pursuit of a deeper understanding of the universe through science and the exploitation of that understanding through technology. Its use may be to attempt the establishment of our sovereignty in opposition to God or it may reflect the divine purposes for the world.

3.5 Progress in science and technology

Already noted above is Stanley Jaki's contention that real scientific creativity depends upon a belief in the objectivity, rationality and order of the created universe. The ancient Greeks had made much progress in science and the development of mathematics but then progress in astronomy and other sciences effectively stopped 'until the arrival of Copernicus, Kepler and Galileo.'²⁴¹ How did it happen that people 'put on a different kind of thinking-cap'²⁴² so that the same information was viewed from a different perspective and huge strides in the understanding of the world were made? Undoubtedly a fresh understanding of God's relationship to the created order was significant. Hooykas notes that a Biblical view of this relationship gradually superseded the patterns of Greek thought which had become attached to the Christian faith so that nature was no longer viewed as god-like²⁴³ but regained its proper contingency. There also developed an interest in mechanism which was applied to the creation such that 'unless the whole system of the universe could be shown to be interlocking, so that it carried the pattern of reasonableness and orderliness'²⁴⁴ it would not be worthy of God. This 'mechanization of the world picture'²⁴⁵ appears to have been a necessary step beyond the de-deification and

²⁴¹ Lewis Wolpert, *The Unnatural Nature of Science* (London: Faber and Faber, 1992), 43.

²⁴² Herbert Butterfield, *The Origins of Modern Science*, 2nd ed. (London: G. Bell and Sons, 1957), 1.

²⁴³ R Hooykaas, *Religion and the Rise of Modern Science* (Edinburgh: Scottish Academic Press, 1973), 9.

²⁴⁴ Butterfield, *The Origins of Modern Science*, 119.

²⁴⁵ Hooykaas, *Religion and the Rise of Modern Science*, 15.

rationalization of the world for science to develop as it did. This is to argue that Christianity played a necessary role in the development of modern science. For progress to happen there had to be a belief that it was possible.

The development of science, however, was preceded by an expansion of technology. The building of cathedrals throughout Britain and Europe had begun by the start of the twelfth century, the foundations of Durham cathedral being laid in 1093, continued with increasing technical sophistication for nearly two hundred years. As the enthusiasm for building cathedrals waned so other inventions were spawned including textile machinery and clocks.²⁴⁶ The interest in clocks in particular may have encouraged the notion of the universe as a mechanism referred to above. To understand why this happened is to attempt to unravel a complex series of interactions between Greek ideas rediscovered in the first renaissance, the technical knowledge of Islam and from even further east, and Christian theology. The work ethic of the monasteries, which was the forerunner of the so-called protestant work ethic²⁴⁷, was also a factor in this, but no understanding can be complete without an acknowledgement of the role of imagination. The interacting ideas referred to above gave plenty of stimulation to the imagination and the people of those times were successful because they were very imaginative people. There were economic factors at work as well, but the machines produced under these stimuli tended to be less technically ambitious than the clock-making projects. Whatever the drivers for technological advance in future centuries 'this was a period when much of the most advanced technology was stimulated by imaginative and not material motives.'²⁴⁸ So even in the development of technology which preceded the rise of modern science, Christian faith and theology had key roles to play.

Today people from widely differing backgrounds and with beliefs other than Christian ones now practice science and technology so that this historical connection seems questionable to some. Wolpert stresses the 'methodological danger' in seeking 'affinities between Christianity and science'²⁴⁹ and argues that if science had arisen in some other area of the world he can readily imagine that Christianity would have opposed it. Such imagination is vital to science but it has to touch base constantly with reality and deal

²⁴⁶ Pacey, *The Maze of Ingenuity*, 25-86.

²⁴⁷ *Ibid.*, 52.

²⁴⁸ *Ibid.*, 86.

²⁴⁹ Wolpert, *The Unnatural Nature of Science*, 48.

with things as they are. It makes no sense to play at constructing alternative histories of science, far better to accept that ‘whereas the bodily ingredients of science may have been Greek, its vitamins and hormones were biblical.’²⁵⁰

Touching base with reality is a vital part of the creative development of science and technology. I believe we are dealing with a real physical world and if our creative ideas are to have any significance they must be constantly relating to that world even if for the moment they see beyond our present horizon. This belief may be described as ‘critical realism.’²⁵¹ The success of science depends on ‘how well its theories correspond with reality.’²⁵² It may be that some novel idea in science fiction, unproven and unthinkable at the time of writing, may be discovered to be true in some future time but that writer will not be the real discoverer for the idea is held purely within the imagination with no known contact with the reality we inhabit. For even though imagination and creativity play a vital part in the growth of scientific knowledge ‘personal knowledge in science is not made but discovered, and....claims to establish contact with reality beyond the clues on which it relies.’²⁵³ It is even more obviously the case that creativity in technology has to mesh with the real world for if it didn’t then the artefacts produced would not function. This constraint leads Hanson to make the slightly outrageous claim that ‘engineering design is the most difficult of all the creative arts’ because ‘the writer, painter, or film maker is not constrained by the realities of the physical world, as the engineer is.’²⁵⁴ Although there is a point to what he is saying in fact ‘the writer, painter, or film maker’ are by no means free of the physical world if they wish to communicate their ideas with others. Even the poet may depend on varying the layout of the poem on the page, the line indentation or word spacing, as well as relying on the sounds of the words and not just their meanings. This reality which undergirds and constrains our creativity is not of our making and within Christian theology it is understood to result from the action of God. This creative activity of God will be the subject of the next chapter but before that a further consideration of science as a creative enterprise is undertaken, followed by an examination of imagination.

²⁵⁰ Hooykaas, *Religion and the Rise of Modern Science*, 162.

²⁵¹ John Polkinghorne, *Exploring Reality* (New Haven: Yale University Press, 2005), 3. See also John Polkinghorne, *One World* (London: SPCK, 1986), 1-42.

²⁵² Wolpert, *The Unnatural Nature of Science*, 2.

²⁵³ Polanyi, *Personal Knowledge*, 64.

²⁵⁴ Hanson, *Engineering Creativity*, 3.

3.6 Creativity in Science

Steiner's view of the inevitability of progress in scientific knowledge making it different as a human activity from 'art' and lacking in creativity bears some examination as it represents a common view that scientists merely discover the facts of the created order. When an eminent scientist such as Richard Feynman publishes under the title of 'The Pleasure of Finding Things Out'²⁵⁵ the emphasis is immediately on discovery, but scientific life is not as simple as that. D. C. Miller, an able experimentalist, repeated the famous Michelson-Morley experiment with better equipment many times over. His results contradicted their findings but even though there was no apparent fault found with his results at the time²⁵⁶ they were not accepted as they contradicted the accepted theory of relativity proposed by Einstein. What Miller actually discovered was that 'apparently impeccable experimental adequacy does not suffice to force acceptance of experimental findings, or to establish factuality.'²⁵⁷ In a hidden way this is a general experience of experimenters, though it is not always recognized as such by the people concerned, and is my personal experience.

In Bristol in 1968 a colleague and I embarked on an experiment as part of our final year in the Bachelor's degree course in Aeronautical Engineering. Whilst we were investigating the possibility of achieving a particular effect in aerodynamic flow which was not subject to precise theory the measurements we made did cover, as a matter of necessity, a range which was covered by such theory. These readings did not fit with that theory and an explanation was sought so that the general findings of the experiment could be maintained. Two possible sources of error were noted and an argument advanced to suggest it was one rather than the other.²⁵⁸ There was never any question in our minds that the mathematically expressed theory could be wrong. That mathematics was an accurate representation of reality was the assumption behind what we had been taught. The real point of the experiment was for us to demonstrate that we were entitled to receive our engineering degrees, that we were competent engineers. Given the initial question to be investigated we did this by devising an experiment, designing the special

²⁵⁵ Richard P. Feynman, 'The Pleasure of Finding Things Out,' in Jeffrey Robbins (ed.), *The Pleasure of Finding Things Out*. (London: Penguin Books, 2001).

²⁵⁶ Polanyi, *Personal Knowledge*, 13 & 13n.

²⁵⁷ Harold K. Schilling, *Science and Religion* (London: George Allen & Unwin, 1963), 103.

²⁵⁸ D. M. Knell and D. Lunn, 'Report 119: Effect of Asymmetry of Aerodynamic Nozzles Operating in near-Critical Conditions,' (Bristol: Dept of Aeronautical Engineering, University of Bristol, 1969), 8.

apparatus, running the experiment, gathering, presenting and interpreting the data and dealing with the anomalies by deploying our knowledge of the wider area of the subject. We had not only learned what we had been taught directly but we had also acquired the tacit assumptions behind the whole enterprise. Had we not had that whole background, which in the case of Derek and I included some workshop practice in industry, we could not even have begun to devise an appropriate experiment, let alone designed the apparatus and taken the readings. It was a few years later, ironically at the point at which I was leaving engineering for ordination, that I began to realise that this depiction of reality was not so simple and I began to wonder how it was that mathematics applies to reality.²⁵⁹

This last paragraph demonstrates a number of aspects of scientific knowledge. My personal experience is in the field of engineering but the overlap and interdependence of science and technology has to be recognized as well as their mutual dependence on mathematics. In other words, we were carrying out a scientific experiment which happened to have a particular practical focus, in the same way as chemistry research might be carried out in order assist the devising of new medical drugs. In scientific knowledge theory is supreme for without it there isn't any knowledge. Theory, that is to say some mental construction about what is true in the world, goes along with our identification of what is in the world and our gathered knowledge about it but actually exceeds it. This is what enables that kind of scientific research which Kuhn²⁶⁰ refers to as normal science to take place. This is research that is 'directed to the articulation of those phenomena and theories that the paradigm already supplies'²⁶¹ where a paradigm is more than theory and includes 'rules and standards for scientific practice.'²⁶² There is a congruence here with what Jaki says about the role of the physicists in the 18th and 19th centuries being to survey the new continent discovered by Newton.²⁶³ Theory provides intellectual concepts and their mutual relationships that broadly define reality, or a particular part of it. When scientists have such a theory they then explore the territory but the knowledge they then gain is already implicit in the paradigm they are working with.

²⁵⁹ For an imaginative answer see Alex Kasman, 'Unreasonable Effectiveness,' *Reality Conditions*. (Washington, DC.: The Mathematical Association of America, 2005), 1-6.

²⁶⁰ Kuhn, *The Structure of Scientific Revolutions*, 23-34.

²⁶¹ *Ibid.*, 24.

²⁶² *Ibid.*, 11.

²⁶³ Jaki, 'Theological Aspects of Creative Science,' 156.

An example can be found within chemistry where, in the 19th century, Kekulé and others developed theories of molecular constitution without which

‘organic chemistry would have remained such as it was described by Wöhler, ‘a monstrous and boundless thicket into which one may well dread to enter’; and its enormous development, which constitutes one of the most remarkable and important features of the chemistry of the second half of the nineteenth century, could not have taken place.’²⁶⁴

This ‘thicket’ is the same as the ‘morass’²⁶⁵ of facts in Pliny or Bacon’s writings that Kuhn hesitates to acknowledge as leading to real scientific knowledge. Kekulé first developed graphic formulae to describe the way strings of atoms formed the aliphatic compounds. However the constitution of the aromatic compounds eluded him for their known physical constituents could not be put into such an order. The breakthrough came with the development of these graphic formulae to involve ring structures of atoms. Organic chemistry still uses these graphics as a sort of language even though our understanding of atomic structure has been transformed since those days.

The example of Kekulé is instructive for several reasons. Firstly, he was developing his understanding on the basis of a theory of chemical atomism which came about by Dalton ‘applying to chemistry a set of questions and concepts previously restricted to physics and meteorology’²⁶⁶, an example of Koestler’s theory of bisociation referred to above. Kekulé was working with this existing paradigm but he brought about a change in the interpretive framework which was necessary because ‘it is logically impossible to arrive’ at such a major discovery ‘by the continued application of our previous interpretive framework.’²⁶⁷ Secondly, Kekulé’s development of theory was led by his imagination or, more accurately, his visual imagination. He described how on two occasions he dozed, once on a bus and once by his fire, and in his dreams he saw the atoms ‘gambolling before my eyes’²⁶⁸, though he indicates that there were other occasions when he had this kind of dream, but presumably without the same sort of significance. In the first dream he began to observe the atoms combining in certain ways and forming chains which he then sketched on paper when he woke. In the second dream, when the problem of the benzene molecule was on his mind, the chains moved in a snake-like way and suddenly

²⁶⁴ Findlay and Williams, *A Hundred Years of Chemistry*, 40.

²⁶⁵ Kuhn, *The Structure of Scientific Revolutions*, 16.

²⁶⁶ *Ibid.*, 139.

²⁶⁷ Polanyi, *Personal Knowledge*, 143.

²⁶⁸ Findlay and Williams, *A Hundred Years of Chemistry*, 38f.

he saw 'one of the snakes had seized hold of its own tail.'²⁶⁹ He woke suddenly and, drawing inspiration from that mental image, worked out the ring structure of the benzene molecule.

Creative imagination lay behind the advances that Kekulé made. This was not simply the reading off from nature a catalogue of facts which science is sometimes made out to be and, because it was an exercise in creativity through which the 'paradigm' (Kuhn) or 'interpretive framework' (Polanyi) was changed, the new ideas met with hostility from members of the scientific community who were hopeful of the existing paradigms yet coming up with explanations. Dalton also faced opposition when putting forward his ideas because scientists are not actually the objective fact-seeking people they like to appear to be for 'science is a system of beliefs to which we are committed'²⁷⁰.

Underneath the apparent facts of nature as they are presented there is an interpretive framework. This framework cannot be the result of induction from experience, and so be guaranteed to be true, for in terms of logic universal statements cannot be derived from singular observations no matter how many of them there are.²⁷¹ The framework conceptualizes beyond the available data of experience and so can be said to be '*underdetermined* by the data'²⁷²

It is also the case that this framework may indeed be tacit rather than openly articulated. Such tacit knowledge and skills will include the 'intellectual powers that we share with animals'²⁷³ which our acquisition of language has immensely expanded so giving us the ability not only to communicate with others, but also to reason with ourselves.

Occasionally the attention of new students will be drawn to some tacit factor such as 'utter honesty' 'which we all hope you have learned in studying science in school'.²⁷⁴ These hidden factors are learned within the community of scientists simply as they are taken for granted in the process of teaching theory and experimental technique as well through practicing standard examples. Margaret Boden is right to think that a 'self-educated crossing sweeper, no matter how intelligent, could not win the next Nobel prize

²⁶⁹ Ibid., 39.

²⁷⁰ Polanyi, *Personal Knowledge*, 171.

²⁷¹ Karl R. Popper, *The Logic of Scientific Discovery* (London: Hutchinson & Co, 1972), 27-48.

²⁷² Hefner, *The Human Factor*, 203f.

²⁷³ Polanyi, *Personal Knowledge*, 132.

²⁷⁴ Feynman, 'Cargo Cult Science,' 209.

for chemistry²⁷⁵ for not only will that person not have access to the necessary laboratory equipment²⁷⁶, but also the background of training and tacit knowledge that comes from the community of chemists will be missing. Research carried out on the way science is taught in school has shown that this involves not merely a giving of information, but also involves the students being ‘apprenticed into ways of reasoning and valuing’ which are of importance in the scientific community, and the students’ subjectivity being shaped, ‘preparing them for the many learning tasks’²⁷⁷ that lie ahead.

It is only when in nature sufficiently great anomalies occur which do not fit into the current framework, and they will occur for ‘it is hard to make nature fit a paradigm’²⁷⁸, that there is pressure to find a new way of understanding. This may be found through the imaginative reasoning of scientists in that particular field of research, or by someone, as in the case of Dalton²⁷⁹, who comes in from a different field and operates with a different paradigm when you can almost guarantee the unacceptability of the new framework simply because of the professional pride of existing practitioners of science in that speciality. Whilst the acceptance of a new framework may depend on factors such as the perceived beauty and simplicity of the new theory and the powers of persuasion of its creators, the key factor leading to its creation will be their imagination.

3.7 Imagination

What I have attempted to show above is that science is a creative exercise of the human imagination as it seeks to understand how reality holds together. Susan Sayers may argue that it is the creative artist who produces an act most nearly analogous to the divine ‘creation out of nothing’²⁸⁰ but when she quotes, at the same time, Berdyaev; ‘God created the world by imagination’, the creative elements in science and technology which also arise out of imagination have to be acknowledged.

²⁷⁵ Boden, *The Creative Mind*, 22.

²⁷⁶ *Ibid.*, 70.

²⁷⁷ Frances Christie, ‘Science and Apprenticeship,’ in J. R. Martin and Robert Veal (eds.), *Reading Science: Critical and Functional Perspectives on Discourses of Science*. (London: Routledge, 1998), 174f.

²⁷⁸ Kuhn, *The Structure of Scientific Revolutions*, 135.

²⁷⁹ *Ibid.*, 133.

²⁸⁰ Dorothy L Sayers, *The Mind of the Maker* (London: Methuen, 1941), 23.

However when Mary Warnock wrote on the subject of the imagination²⁸¹ her focus was primarily on the visual arts and literature, especially poetry, as this was the principal area that the philosophers she expounded had been considering. Her starting point was the problem of the relationship between what goes on in my head and what appears to exist in the world external to me and she notes that with Locke and Berkley there is no sharp distinction between perceiving an object when it is apparently present and thinking about it when it is not. Hume introduced a distinction between our perceptions and our thoughts but this turns out to be a matter of degree only in the ‘force and vivacity’²⁸² with which these appear in our minds. Generally speaking for Hume the images in our minds of the impressions presented by our perceptions are much fainter than the perceptions themselves. Similarly the memory of a perception has a greater ‘force and vivacity’ than the idea of it used in the imagination. Furthermore memory is seen as limited to repeating perceptions in the order in which they first happened whereas the imagination has a greater freedom to combine perceptions in new ways.

Such an account of the functioning of memory does not fit well with modern understandings where it is seen that we have a ‘dynamic memory system’ because we need ‘to update the knowledge we have stored and to transform the models of the world we construct in our heads.’²⁸³ Memory, it appears, also involves imagination. This is not to denigrate Hume or others who have ventured to understand the workings of the human mind. Rather it is to note that we have more data to work with and not that all the questions have been answered. Workers in the field of memory, say, will generally acknowledge that many of the often rapid mental processes that human beings employ in everyday life ‘are simply not accessible to conscious awareness.’²⁸⁴ The result is that very imaginative experiments have to be devised in order to shed light on these mental processes, including imaginative activity, and the imagination itself has to be employed to construct an understanding of what is going on. In essence what Hume was attempting to do, whether or not this was fully appreciated by him, was to use his imagination on the

²⁸¹ Mary Warnock, *Imagination* (London: Faber and Faber, 1976).

²⁸² *Ibid.*, 15.

²⁸³ Gillian Cohen, 'Overview: Conclusions and Speculations,' in Gillian Cohen and Martin A. Conway (eds.), *Memory in the Real World*. (Hove, East Sussex: Psychology Press, 2008), 385.

²⁸⁴ Gillian Cohen, 'The Study of Everyday Memory,' in Gillian Cohen and Martin A. Conway (eds.), *Memory in the Real World*. (Hove, East Sussex: Psychology Press, 2008), 9.

data of introspection that he had to hand and the ideas he had received from others to understand human mental processes including imagination.

To some people this may seem like a hopelessly circular process, but we need to remember that the understandings proposed by philosophers and scientists do need to cohere in some way with reality as experienced by other people as well as themselves. This is the basis of amendments and counter proposals that are brought forward when ideas and theories are scrutinised by wider groups of people. Warnock charts this interplay in her exploration of imagination which moves from Hume to Kant, Schelling, Coleridge, Wordsworth, Wittgenstein and Sartre. The detail of her analysis is beyond the scope of this present work but it is worth noting her reference to Coleridge's division of the imagination into 'primary' and 'secondary'. The former is 'the function of the imagination in all perception of and therefore all knowledge of the world'²⁸⁵ whilst the latter is the poetic faculty. Warnock admits that Coleridge does not maintain this distinction in all his philosophical writings but it is an important acknowledgement that in seeing and understanding the world our minds are not passively, as it were, simply receiving the truth about this external world through sensory data. Our imagination is actively involved in taking this data and building an understandable world. This world is open to further imaginative treatment in seeing deeper connections between the particulars of our perception as in a poetic sense exemplified by Coleridge's identification between a 'white eddy-rose' in the River Greta and 'the life that we live.'²⁸⁶ This internal construct of the world is also open to the imaginative proposals of alternatives and possibilities which feature in art, literature and technology.

Once again it has to be emphasised that to recognise the work of the imagination in constructing our vision and understanding of the world is not to reduce 'the world to a dreamlike and insubstantial status'²⁸⁷ as Wordsworth feared as a boy when he needed to touch objects to be assured of their reality. The imaginative construct that exists in our heads has to cohere with our ongoing life in the world and that of other people with whom we communicate.

²⁸⁵ Warnock, *Imagination*, 91.

²⁸⁶ See *ibid.*, 85 & 99.

²⁸⁷ *Ibid.*, 103.

In the end, having considered the nature of the mental image through an examination of both Wittgenstein and Sartre, Warnock settles on an understanding of the imagination which she sees as developed by Wordsworth. She declares that it seems to her ‘both plausible and convenient to give the name “imagination” to what allows us to go beyond the barely sensory into the intellectual or thought-imbued territory of perception.’ In saying this she wishes to keenly resist any notion of cold imagination or reason being purely at work in this process for its ‘impetus comes from the emotions as much as from the reason, from the heart as much as from the head.’²⁸⁸ I would not resist such a suggestion even for the growth of scientific knowledge of the world. For this is a form of human knowledge gained by human beings working in particular human ways. Richard Feynman speaks of an artist friend who considers that scientists take a beautiful thing, such as a flower, and turn it into a ‘dull thing’. Feynman objects that he sees more beauty than the artist because he sees the beauty of the cells of the plant, their complicated processes and inner structure as well as their interactions with insect pollinators. ‘It only adds; I don’t understand how it subtracts.’²⁸⁹ The appreciation of beauty comes into the development of science and ‘wonder can inspire the imagination both to operate creatively and to illuminate the structures of reality.’²⁹⁰

This way of understanding the importance of the imagination as ‘a necessary route to reality’²⁹¹ is reinforced by the finding of those working to discover the mental processes that underlie our human interaction with the world. Reference has been made above to the scientific exploration of memory which understands it as a dynamic faculty and not simply a reading and replaying of sensory data. In the field of visual perception a main problem is that ‘*the sources of any retinal stimulus are unknowable directly,*’ because that stimulus depends on light emitted by or reflected from an object’s surface, and ‘any element of a visual stimulus could have arisen from many – indeed, infinitely many – different objects and conditions.’²⁹² Purves and Lotto’s solution, which is to suggest that ‘what observers actually experience in response to any visual stimulus is its

²⁸⁸ Ibid., 195f.

²⁸⁹ Feynman, ‘The Pleasure of Finding Things Out,’ 2.

²⁹⁰ Douglas Hedley, *Living Forms of the Imagination* (London: T & T Clark, 2008), 67.

²⁹¹ Ibid., 39.

²⁹² Dale Purves and R. Beau Lotto, *Why We See What We Do* (Sunderland, Ma. USA: Sinauer Associates, 2003), 5.

accumulated statistical meaning,²⁹³ may have some explanatory power but it raises the question of how we can see something we have never seen before. This is especially significant for their theory when what is seen has no immediate significance for survival. When images of the earth seen at a distance from space²⁹⁴ were available I could readily understand them because I held an imaginative mental understanding of the world and universe into which they fitted and expanded that understanding. This attempt to provide a mechanistic way of understanding vision still needs the human faculty of imagination.

So we find that Warnock's humanities based exploration of imagination has linked to our everyday understanding of the world around us and through that it links to the more developed scientific exploration of that world. The imagination is vital for the whole of our human understanding of the world and creative activity within it not just the parts we label 'scientific' or 'artistic.' This even applies within the realm of religion where, for instance, David Brown argues that in the history of Christianity the imagination has generated new insights 'which the Christian may legitimately regard as revelation, not merely human responses but divinely motivated.'²⁹⁵ In fact the imagination has to be deployed 'in order to interpret other complex rational agents: language users and members of specific historical cultures.'²⁹⁶

It is because human beings are so imaginative that they have the 'distinctive amphibious capacity'²⁹⁷ to both live within the natural world and to transcend it with ideas of understanding and transformation. Creativity can then be regarded as the imaginative activity which bears novel fruit which is accessible to other people in the real world. This fruit may be a recipe, poem, holiday itinerary, symphony, fantasy novel, scientific theory or an iPhone app etc.

One way this imaginative and creative activity expresses itself is through the use of the future tense in language along with the subjunctive and optative moods.²⁹⁸ Hope, 'a transcendental inference,'²⁹⁹ is expressed using these means. The emergence of the

²⁹³ Ibid., 226.

²⁹⁴ See for example: John D. Barrow, *Cosmic Imagery* (London: The Bodley Head, 2008), 154, 62.

²⁹⁵ David Brown, *Discipleship and Imagination* (Oxford: Oxford University Press, 2000), 31.

²⁹⁶ Hedley, *Living Forms of the Imagination*, 39.

²⁹⁷ Ibid., 37.

²⁹⁸ Steiner, *Grammars of Creation*, 5.

²⁹⁹ Ibid., 6.

future tense marks the growth of human transcendence, that ability to see beyond the brute facts of present experience, to perceive the patterns at work through memory and to see them going into the future. Here is imagination at work. Different possibilities are imagined as the outcomes of varying courses of action that might be taken and consideration given to how the most favourable one might be achieved. The subjunctive and optative are clearly involved in this process which grows into the weighing up of how another person might react to that which I propose. Perhaps this sense of individual purposefulness was the seed, sensing some unknown driving purpose behind the perceived world, of the belief in a deity. It is the future tense with its imaginative and transcendent nature that expresses hope and fear which are themselves the compulsion to seek alternative actions. Whereas Steiner has his focus on grammar, I believe, as shown above, that imagination plays a large role in creativity. It is imagination that enables future alternatives to be apprehended which can then be creatively brought about. Even though we do not fully understand how human beings are imaginative and creative we know these two processes are intimately linked in the human mind. This implies that if a nonhuman intelligence, such as a computer, were genuinely creative it would be able to imagine.

Whether computers could be really creative as distinct from just apparently so is an issue in the development of artificial intelligence. In view of the earlier discussion of the physicality of creativity it would appear that such a creative machine would need a complete array of sensors in order to have conveyed to it the wide range data concerning itself and the reality in which it is set. It would also need some imaginative capacity to organise the data and consider possibilities beyond the given that still relate to the real world. Also needed would be some forms of intelligence, understanding and consciousness. Because these are facets of being human in our experience it is easy to discount the possibility of them occurring in a machine. But Margaret Boden doesn't. Her discussion of these issues reveals how little we know of them anyway or indeed what sort of intelligence, understanding and consciousness is needed for creativity to happen, and therefore the uncertainty that these things can never be achieved.³⁰⁰ But she still gives a negative answer to the question as to whether computers could be really creative for an entirely different reason. Human beings must retain the moral responsibility and

³⁰⁰ Boden, *The Creative Mind*, 285-300.

epistemological authority because ‘our moral attitudes and general sympathies are much influenced by biologically-based factors.’³⁰¹ That is to say the characteristics and nature of our mind come packaged with a particular type of body. And that brings us back to that area of concern expressed in the previous chapter by Ellul and Malet of the dangers of giving ourselves over to technological values rather than human ones.

3.8 Summary

Human creativity takes place within the context of God’s created order and if it is to be of significance it has to relate constantly to that order as we do not have the capacity to create a different one, except perhaps in our imaginations and fantasies. It is our capacity for imagination, the building of mental models of the world around us, that we find the starting point of our creative activity. Knowledge also requires some form of mental model, referential framework, of how things relate together so that those relationships can be explored in depth and perhaps be exposed as inadequate representations of reality when predicted outcomes fail. Language is a key element in this process as it allows objects to be named and manipulated and ideas to be communicated. Imagination acts as a transcendent ability for as we use it to create our mental models so it enables us to go beyond reality as it immediately appears to us. It allows us to consider alternatives as to how we might act, how new objects may be brought into being and how other people might react to what we do. This facility undergirds our everyday living and knowing in the world and our specialised knowledge activities of science and technology as well as music, art, literature and architecture. All these things are rooted in the physical world and in our mental powers.

What we term creativity is a product of imagination and this ability is not limited to just a few people and certainly not in isolation. Rather than seeking to develop special theories of creativity what is needed to explain this phenomenon is ‘a complete theory of thinking.’³⁰² Of course, as with other abilities and talents, some people have developed greater facility in creativity than others and some so stand out above the crowd that we regard them as geniuses. But even these still belong in a social and cultural context. As we shall see in the next chapter the Christian understanding of God as Creator and as

³⁰¹ Ibid., 299.

³⁰² Weisberg, 'Creativity and Knowledge: A Challenge to Theories,' 249.

Trinity permits us to see that within the interactions that take place in science and technology there is creativity being expressed in a collaborative form.

Chapter 4

Creation, Creativity, and the Image of God

This investigation into creativity was stimulated by the inadequacy of attempts to develop a theological understanding of technology in which it had become objectified and considered ‘to have an existence separate and distinct’³⁰³ from the human beings who produced it. In the previous chapter the working of creativity, closely linked to imagination, has been explored as a human phenomenon which is a feature of our everyday knowledge of the world as well as our specialised scientific knowledge. In this chapter the idea of human creativity taking place in and being part of God’s creation will first be explored through the examination of the Old Testament creation narratives in Genesis. Particular focus will be on the expression ‘Image of God’ which is used of human beings in the first chapter of Genesis. The ‘Garden of Eden’ story will also be discussed from the point of view of understanding the present context in which human creativity is exercised. This will be followed by a consideration of the significance of the Christian doctrine of the Trinity for human creativity including Steiner’s problem of the multiple authorship of scientific research reports.

It was seen that most of the writers of the essays reviewed in Chapter 2 above made their contribution without any significant attempt to relate their thoughts to the Christian Bible. This is one of the causes of the inadequacy of those essays as Christian theology. Therefore it is important that serious attention is given to the Bible but first, because the Bible is a complex literary collection, some consideration of how it will be approached and interpreted must first be given.

4.1 The Place and Use of the Bible

The Bible, Christian scripture, is the foundational written document of the Christian Church to which it turns for authoritative guidance on matters of faith and conduct. The branch of the Church to which I belong, the Church of England, speaks of a three-fold basis for theological enquiry of scripture, tradition, and reason.³⁰⁴ However, because of my more ecumenical background I believe this list needs to include ‘experience’, in keeping with the ‘Wesleyan quadrilateral’, to open the way ‘for a fruitful dialogue with

³⁰³ Florman, *The Existential Pleasures of Engineering*, 49.

³⁰⁴ As elucidated by Polkinghorne, *One World*, 30-33.

other sources of truth.³⁰⁵ These four elements are not on an equal footing for ‘the Bible serves as the primary authority for matters regarding Christian theology and ethics.’³⁰⁶

The Bible came into existence through the writing and editing work of many people who were responding to their experience of God’s acts in history. As such the Bible is ‘a testimony pointing beyond itself to a divine reality to which it bears witness.’³⁰⁷ This testimony is given by many witnesses in the Old and New Testaments, but for the Christian Church the principal event to which witness is given is the resurrection of Jesus Christ. This is understood as the act of God which gives the Church its gospel and its mission which is ‘to see to the speaking of the gospel.’³⁰⁸ The writings of the New Testament ‘bear witness to this act as the object of the faith of the church and of individual Christians’³⁰⁹ but they were never seen in isolation from the witness to the historical experience of God that is contained in the Old Testament. The writings that were included in the New Testament Canon were those ‘from which could be heard the teaching of the apostles.’³¹⁰ By being included in the canon the writings were not given authority by the Church, rather they were included because their authority was recognised. The Old Testament canon was accepted from Judaism on the basis that its books were acknowledged as the witness to God’s earlier revelatory acts in the history of Israel so setting the broader historical context of God’s act in Jesus Christ.

The continuing successful use of the two canons in the Christian Bible by the Church can be understood by analogy. Evolutionary epistemology demonstrates that ‘the information that living organisms get from the world is sufficiently accurate to allow for survival and reproduction.’³¹¹ In a similar way Christians and the Church have gained sufficiently accurate information about God and the world from the Bible to sustain their continued ‘survival and reproduction.’ The emphasis here is on ‘sufficiently accurate’ information rather than ‘absolutely accurate’ or ‘inerrant’ information. The existence of

³⁰⁵ Wilkinson, *Christian Eschatology and the Physical Universe*, 55.

³⁰⁶ Richard P. Thompson, 'Authority Is What Authority Does,' in Richard P. Thompson and Thomas Jay Oord (eds.), *The Bible Tells Me So (Kindle Edition)* Kindle ed. (Nampa, Idaho: SacraSage Press, 2011), loc 814.

³⁰⁷ Brevard S. Childs, *Biblical Theology of the Old and New Testaments*, Kindle ed. (Minneapolis: Fortress Press, 1992), loc 936.

³⁰⁸ Robert W. Jenson, *Systematic Theology*, 2 vols., vol. 1 (New York: Oxford University Press, 2001), 11.

³⁰⁹ Wolfhart Pannenberg, *Systematic Theology*, trans. G. W. Bromiley, 3 vols., vol. 1 (Grand Rapids: William B. Eerdmans, 1991), 15.

³¹⁰ Jenson, *Systematic Theology*, 27.

³¹¹ J. Wentzel Van Huyssteen, *Alone in the World?* (Grand Rapids: William B. Eerdmans, 2006), 93.

misunderstandings or mistakes does not nullify this view. The writings in the Bible are human compositions, both in terms of original authors and later editors and compilers, which reflect their historical and cultural origins. In this God is revealed as allowing the gospel to be carried by human speakers and writers with all the risks this entails.

‘The Bible represents God as the preeminent speaker’ through whose words we understand that ‘as beings created in God’s image, humans too have the capacity to communicate and to understand,’³¹² even though this capacity is affected by human finitude and sinfulness. Vanhoozer’s development of ‘speech act theory’ expressed as the triune God being the ‘epitome of communicative agency: the speech agent who utters, embodies, and keeps his Word,’³¹³ is a helpful picture of how God can communicate in this situation. Because ‘sufficiently accurate information’ is available I have the confidence to look to the Biblical writings, witnessing as they do to God’s historical revelatory acts, to afford some clues about the relationship between God and God’s creation in order to understand the place of human technology. It is to be hoped that this will be an act of the imagination undertaken with the assistance of the Holy Spirit who is Vanhoozer’s ‘keeper of God’s Word’. In this way what follows and indeed the whole argument of this thesis may contribute to the ‘continuous stream of developing tradition.’³¹⁴

Human technology was not a pressing concern of the writers and compilers of the Old or New Testaments. My cultural baggage is different to that which they carried. There are then clear biases in my approach but this does not of itself automatically rule out the validity of any answers gained because no-one approaches the text from a neutral position. Not only is it true that ‘how we read the text depends on why we read the text’³¹⁵ but also ‘the perspective within which the exegete works, and the language he employs, have been shaped by the history of the culture to which he belongs.’³¹⁶

³¹² Kevin J. Vanhoozer, *Is There a Meaning in This Text?* (Leicester: Apollos (IVP), 1998), 205.

³¹³ *Ibid.*, 457.

³¹⁴ Brown, *Tradition and Imagination*, 169.

³¹⁵ R. W. L. Moberly, ‘Paradigms for Pentateuchal Criticism,’ *The Old Testament of the Old Testament*. (Minneapolis: Fortress Press, 1992), 182.

³¹⁶ Nicholas Lash, ‘What Might Martyrdom Mean?’, *Theology on the Way to Emmaus*. (London: SCM Press, 1986), 77.

Middleton's comment is apposite: 'It is amazing how the assumptions that one brings to the text determine what one is allowed to see.'³¹⁷

The exercise of establishing what the text actually says and the historical context in which it was said, so that meaning may be established, is already an interpretive task, and has always been so for 'it was always innocent as well to suppose that the acceptability or otherwise of scholarly ideas had nothing to do with fashion, trends or influence.'³¹⁸

However this means neither that the task in which I am engaged is too difficult to be attempted, nor that I can simply use the historic documents in a cavalier fashion as proof texts for an established opinion using some doctrine of inspiration as a cover. Rather the task has to be approached with caution and humility acknowledging that, in some way which cannot be clearly defined, God has inspired the writers through a historical process in which God has been interacting with the people of Israel. What is being sought is illumination on the questions of the nature of God, God's creation and the human race and the relationships between them so that some understanding of the place of technology therein may be ascertained.

It is vital that the 'historical integrity' of the text 'be respected'³¹⁹ for they do come from cultures separated in many ways from my own. However it is possible to develop some imaginative understanding of these people and situations because, not only is there a faith connection between us, but also we share a common humanity. These different contexts are not 'always mutually 'impermeable'.'³²⁰ On that basis much study of the Old Testament texts has been carried out over the millennia. In recent centuries the Pentateuch has been examined by many scholars to discover the earlier documents and traditions from which it was assembled. The whole process has been aided in recent centuries by the huge number of archaeological finds which have helped us to understand the culture of the ancient Near East and so provide a wider context in which to interpret the biblical texts themselves.

³¹⁷ Richard J. Middleton, *The Liberating Image* (Grand Rapids: Brazos Press, 2005), 205 n. 64.

³¹⁸ David J. A. Clines, 'Philology and Power,' in David J. A. Clines and Philip R. Davies (eds.), *On the Way to the Postmodern*. (Sheffield: Sheffield Academic Press, 1998), 613 n.64.

³¹⁹ Moberly, 'Paradigms for Pentateuchal Criticism,' 184.

³²⁰ Lash, 'What Might Martyrdom Mean?,' 77.

A significant way of understanding the Genesis texts under examination in this chapter has been the documentary hypothesis in which the existing text is perceived as an interwoven compilation of earlier texts. Examining ancient texts in this way is not simple. Early in the twentieth century Jastrow attempted to establish the documents behind the 'Gilgamesh Epic' and identified four currents in the Epic in examining the literary relationship between the Old Babylonian and Assyrian versions.³²¹ Subsequent to his work archaeologists have discovered many more fragments of the text and the Sumerian stories on which it was based. This has allowed a more precise charting of the development of the text and its relationship to its literary sources. The result of this exercise has been 'sobering' for the literary critic as it has been revealed 'how much room there would be for error in trying to construct those sources from the texts of the epic alone.'³²² There is now a widespread recognition of the 'hypothetical character of the results of modern criticism.'³²³ However scholarly imagination has yet to come up with an 'alternative paradigm of comparable comprehensiveness and explanatory power'³²⁴ that is able to command a broad scholarly consensus in the study of Genesis and the rest of the Pentateuch.

Our search for knowledge is subjective even when directed at an objective reality. Our investigations are like searchlights where what 'the searchlight makes visible will depend upon its position, upon our way of directing it, and upon its intensity, colour, etc.; although it will, of course, also depend very largely upon the things illuminated by it.'³²⁵ This is not to say that that source criticism and other techniques used in biblical study are futile but to acknowledge that such study is difficult and the results are provisional. To admit this does not mean that they are worthless, but rather that we are still on the road seeking even better illumination. With that in mind we now come to the opening chapter of Genesis.

³²¹ Morris Jastrow and Albert T. Clay, *An Old Babylonian Version of the Gilgamesh Epic* (New Haven: Yale University Press, 1920), 52-60.

³²² Jeffrey H Tigay, *The Evolution of the Gilgamesh Epic* (Philadelphia: University of Pennsylvania Press, 1982), 248.

³²³ Gordon J. Wenham, *Genesis 1 - 15*, ed. John D. W. Watts, *Word Biblical Commentary* (Waco, Texas: Word Books, 1987), xxxv.

³²⁴ Moberly, 'Paradigms for Pentateuchal Criticism,' 177.

³²⁵ Karl R. Popper, *The Open Society and Its Enemies*, 5th paperback ed., vol. 2 (London: Routledge & Kegan Paul, 1966), 260.

4.2 First Creation Narrative in Genesis

The opening chapters of Genesis serve to set the scene, in terms of the relationship between God, human beings and the rest of God's creation, for the narration of an account of human history largely in terms of genealogies. This account comes to focus upon Abram and his family, putting in the necessary background to the Exodus events which are the central part of the Pentateuch.³²⁶ This means that the God who rescued the people of Israel is identified as the one God who created the whole world and all the people and other creatures within it. We are not dealing with a tribal deity, the writer/compiler of the Pentateuch is telling us, but with the one God to whom all humans owe their being whether or not this God is acknowledged by them. The first eleven chapters of Genesis from the creation of the world to the first mention of Abram will have a long history of tradition both oral and written, but the underlying sources are not easy to separate out. Traditionally different names for God, style and language, discrepancies in the text, repetitions and theological differences have been used to identify the documents underlying the present text, but a great deal of care has to be employed as Westermann³²⁷ has argued in order that the 'multivoiced character'³²⁸ of the text may be appreciated.

The first chapter of Genesis is generally regarded as belonging to the priestly source 'P'. In this chapter it is not easy to separate out the different voices. The deep (*tehom*) of verse 2 may be, etymologically speaking, a reminiscence of the name Tiamat the salt-water goddess of Babylonian mythology who was slain by Marduk. In verse 6 God separates the 'waters above' from the 'waters below' which is suggestive of the splitting of the corpse of Tiamat, to form the heavenly and earthly realms, by Marduk after his victory over her. But such is the use of *tehom* in the Old Testament, e.g. never as a proper name, and the difference between the accounts of creation in Genesis and the Enuma Elish epic at the point of the division of the waters that it is unwise to seek direct literary dependence.³²⁹ In the narrative there are six working days for God but eight things to do, and God is said to create by speaking on some occasions and by making on others but

³²⁶ Claus Westermann, *Genesis 1-11: A Continental Commentary*, trans. John J. Scullion (Minneapolis: Fortress Press, 1994), 2.

³²⁷ *Ibid.*, 576-88.

³²⁸ David M. Carr, *Reading the Fractures of Genesis* (Louisville, Kentucky: Westminster/John Knox Press, 1996), 3.

³²⁹ Westermann, *Genesis 1-11: A Continental Commentary*, 105 & 18.

even so it is difficult to separate out the different strands of underlying documents and it seems preferable to simply have some general idea of a complex background of creation stories which the writer of Genesis 1 has drawn upon. The text as we have it can be ‘explained much better by the confluence of many strands of traditions and motifs from a variety of earlier creation stories.’³³⁰

This view is encouraged by the fact that other scholars find connections to Egyptian texts containing such ideas as God (Ptah) creating by speech, and people in general being made in the image of the god Re³³¹, and yet others find reasons, such as numerical symmetry, which serve as a ‘convincing proof’³³² of the unity of this first chapter of Genesis. Despite all the ancient documents relating creation stories and other tales found by the archaeologists ‘we are terribly ill-informed regarding the history of either Mesopotamian or biblical creation accounts’³³³ and also the Egyptian ones. However they do form a background against which to interpret Genesis especially when consideration is given to the fact that, whilst there many voices present in the text, they have largely been silenced by the final editor, P.

Westermann’s analysis of P that he knows that ‘as he speaks he allows others to speak with him at the same time’³³⁴ must be questioned. When the text is set against what is known of its wider cultural context we see that in Genesis there is no warfare between the gods as the background to the creation of the world for there is only one God. Neither is there a need to slay a god or gods in order to mingle their blood with clay in the fashioning of these human beings who, anyway, are not created to relieve some gods of their workload and to provide cultic worship and provisions for the gods.³³⁵ Another significant omission is that the deep and the waters that are divided are not shown as a threat to God or the creation. God does not have to battle with them in order to create the world and they are not shown as a continuing threat to it. Significantly the ‘great sea monsters’ are created by God in verse 21 and not battled against and defeated as they are

³³⁰ Ibid., 89.

³³¹ Rikki E. Watts, ‘On the Edge of the Millenium: Making Sense of Genesis 1,’ in Hans Boersma (ed.), *Living in the Lamblight*. (Vancouver: Regent College Publishing, 2001), 139f.

³³² U. Cassuto, *A Commentary on the Book of Genesis* (Jerusalem: Magnes Press, 1978), 15.

³³³ John H. Walton, *Ancient Israelite Literature in Its Cultural Context* (Grand Rapids: Zondervan, 1989), 36.

³³⁴ Westermann, *Genesis 1-11: A Continental Commentary*, 173f.

³³⁵ Middleton, *The Liberating Image*, 149-67.

in Psalm 74.13 where the same word is translated as ‘dragons’. This psalm is one of only three Old Testament texts, the others being Job 26.7-14 & Psalm 89.9-14, which Middleton³³⁶ is prepared to concede still contain a clear reference to the idea of ‘creation-by-combat’.

Whether or not that is the case, the point is that, in Genesis 1, this idea of God having to battle primeval forces of darkness and chaos in order to establish his creation is one of those voices that the author has silenced. Whilst this voice may still be heard in other parts of the Old Testament as well as the idea of God combating the forces of evil in Israel as well as in the wider world, it is clear that in Genesis 1 the possibility of violence being intrinsic to the nature of God is pushed away. In contrast to Enuma Elish this account ‘is extraordinarily peaceful in its representation of creation.’³³⁷ Batto’s claim that the priestly writer presents ‘the Abyss’ as ‘a force which must be subdued in order for the Creator’s design to come into being’³³⁸ carries no more weight than the suggestion that the hymn ‘Eternal Father strong to save’ is evidence for an Anglican belief in creation-by-combat because of verse three:

‘O Holy Spirit, who didst brood
upon the waters dark and rude,
and bid their angry tumult cease,
and give, for wild confusion, peace,’

where, superficially at least, the reference is even clearer than in Genesis 1. Another small sign of this silencing of violence is that when God identifies the sources of food for human beings (Genesis 1.29) animals are not included, there is no permission at this point for animals to be killed, for violence to be used on them.

A further significant point in this creation narrative is that not only are all living creatures created beings, but the sun, moon and stars are clearly identified so as well. In Gen.1.14-18 the sun and moon are not named but identified by their purpose ‘to separate the day from the night’ and ‘to rule over the day and the night’ so eliminating any thought that they are divine and to be worshipped. This was done because the writer, aware of the polytheism of the surrounding nations, was concerned ‘that the mere naming of things

³³⁶ Ibid., 244-50.

³³⁷ Mark G. Brett, ‘Earthing the Human in Genesis 1-3,’ in Norman C. Habel and Shirley Wurst (eds.), *The Earth Story in Genesis*. (Sheffield: Sheffield Academic Press, 2000), 75.

³³⁸ Bernard F. Batto, ‘Creation Theology in Genesis,’ in Richard J. Clifford and John J. Collins (eds.), *Creation in the Biblical Traditions, Catholic Biblical Quarterly Monograph Series; 24*. (Washington, DC: Catholic Biblical Association of America, 1992), 32.

many considered to be gods might lend credence to their divinity'³³⁹ This focus on the one supreme creator God, who rescued the people of Israel in the exodus, is the same belief that underlies the message of the prophets such as in Jeremiah 27.4f:

‘Thus says the Lord of hosts, the God of Israel: This is what you shall say to your masters: It is I who by my great power and my outstretched arm have made the earth with the people and animals that are on the earth, and I give it to whomsoever I please.’

The nature and exercise of God’s sovereignty is, however, not what it might seem at first glance. The words of command used by God are not imperatives but rather jussives which soften their force so that ‘the command is not authoritarian. God gives permission for creation to be.’³⁴⁰ The use of the jussive, which is ‘a shortened form of the imperfect to express the quick reaction of the mind to a situation’³⁴¹, has another effect in that it gives the impression that God has not got some mental blueprint for creation which is then being rolled out in precise order and detail. There is a clear sense in which God is working things out as they progress. The process is open rather than the closed following an existing detailed plan. This is seen in that God also invites elements created so far to participate in the next stage:

‘Let the earth put forth vegetation’ (Gen. 1.11),
‘Let the waters bring forth swarms of living creatures’ (Gen. 1.20),
‘Let the earth bring forth living creatures of every kind’ (Gen. 1.24).

In the second and third instances the creative act is then retrospectively attributed directly to God (Gen. 1.21 &25). The picture of God being advanced here is not authoritarian, however benevolent, or despotic. God is open to the creation playing its own part in the ongoing work. There is even the sharing of God’s ‘rule’ with the sun and the moon, both created beings with defined scopes of operation. This rule is shared especially with human beings created in God’s own image and given a particular domain. This idea of God actually interacting with God’s creation is a difficult one for if taken seriously it means that creation may have an effect on God. This is an idea which to we will return later.

³³⁹ Bernard F. Batto, *Slaying the Dragon: Mythmaking in the Biblical Tradition* (Louisville, Ky.: Westminster/John Knox Press, 1992), 84.

³⁴⁰ Walter Brueggemann, *Genesis*, ed. James Luther Mays, Patrick D. Miller, and Paul J. Achtemeier, *Interpretation: A Bible Commentary for Teaching and Preaching* (Atlanta: John Knox Press, 1982), 30.

³⁴¹ R. K. Harrison, *Biblical Hebrew, Teach Yourself Books* (London: Hodder and Stoughton, 1979), 81.

4.3 Creation of Humankind in the Image of God

The supremacy of God over creation having been established and the relationship between them explored, the creation of human beings and their place in God's scheme of things comes now into view. The starting point is Genesis 1.26-28:

‘Then God said, ‘let us make humankind in our image, according to our likeness; and let them have dominion over the fish of the sea, and over the birds of the air, and over the cattle, and over all the wild animals of the earth, and over every creeping thing that creeps upon the earth.’
So God created humankind in his image,
in the image of God he created them;
male and female he created them.
God blessed them, and God said to them, ‘Be fruitful and multiply, and fill the earth and subdue it; and have dominion over the fish of the sea and over the birds of the air and over every living thing that moves upon the earth.’

The next verse details the dietary provision for them of every seed bearing plant and tree.

God's use of ‘us’ and ‘our’ here, and only here in the first creation narrative, raises a problem given the clear focus on the singularity of God in the telling of the story of creation. Because of the deliberation with which this opening chapter has been put together it is unlikely to be an oversight from an earlier source particularly as there is a reversion to the singular when God carries out the plan. This also rules out the idea that God is addressing a heavenly host. Middleton does interpret the addressee as the heavenly host but this requires the meaning of ‘*elohim*’ to change from ‘God’ to ‘the gods’ within the space of a few words in verse 27.³⁴² In modern English the plural could readily be taken as a plural of majesty but that would be a novelty in the Old Testament. Another idea is that it ‘does imply a limited form of duality’³⁴³ so interpreting the creation of male and female in the image of God as indicating there is no lack within God. This is also rejected because ‘the idea that God might possess any form of sexuality, or any differentiation analogous to it, would have been for P an utterly foreign and repugnant notion.’³⁴⁴ Interpreters in the early church often seized upon the plural as speaking of the Trinity. Leupold still prefers this Trinitarian explanation seeing it ‘in a

³⁴² Middleton, *The Liberating Image*, 55-60.

³⁴³ Robert D. Sacks, *A Commentary on the Book of Genesis, Ancient Near Eastern Texts and Studies* (Lewiston, New York: Edwin Mellen Press, 1990), 16.

³⁴⁴ Phyllis A. Bird, ‘“Male and Female He Created Them”: Gen 1:27b in the Context of the Priestly Account of Creation,’ *The Harvard Theological Review* 74, no. 2 (1981): 148.

kind of obscure adumbration³⁴⁵ but understands that this is not what the original author understood. Such interpretation is ‘a dogmatic judgment,’³⁴⁶ a reading into the text of what is not there and which reveals the operation of imagination and creativity within the Christian community when it deals with the Old Testament from a perspective different to that from which it had been written. Clines proposes that a duality within the Godhead is being referred to and that the addressed partner is God’s spirit who has appeared in verse 2.³⁴⁷ Once again an interpretation is being sought that goes beyond what the original author intended. Perhaps the most likely explanation ‘because of its comparative lack of disadvantages,’³⁴⁸ is that it is a plural of deliberation³⁴⁹ and whether this is correct or not the use of the plural certainly emphasises the special significance of the creation of human beings over against the rest of the created order.

Human beings are created in the same space immediately after the land animals on the same day so ‘there is more that connects us with nature than there is that distinguishes us.’³⁵⁰ But by the expression ‘image of God’ human beings are made distinct from everything else that God has created for it is never applied to any other creature. Human beings stand unique in the world as bearing this image. In some way human beings, and only human beings, resemble God. Against a wider cultural background where statues and other images were used to represent the different gods of the surrounding nations the making of them was forbidden to Israel. The 4th Commandment states; ‘You shall not make for yourself an idol, whether in the form of anything that is in the heaven above, or that is on the earth beneath, or that is in the water under the earth.’ (Ex. 20:4) If people wish to ask the question; ‘What is God like?’ the answer is given by the writer of Genesis 1: ‘There is one way in which God is imaged in the world and only one: humanness!’³⁵¹ But the question as to what this means has been the subject of much research and debate over the centuries. Berkouwer is quite sure that there is in the Bible ‘no explanation given as to exactly what this likeness consists of or implies’³⁵², but he specifically excludes the possibility that it refers to dominion over creation, seeing that as something

³⁴⁵ H. C. Leupold, *Exposition of Genesis* (London: Evangelical Press, 1972), 86.

³⁴⁶ Westermann, *Genesis 1-11: A Continental Commentary*, 144.

³⁴⁷ Clines, ‘Humanity as the Image of God,’ 463f.

³⁴⁸ *Ibid.*, 463.

³⁴⁹ Westermann, *Genesis 1-11: A Continental Commentary*, 145.

³⁵⁰ Anna Case-Winters, ‘Rethinking the Image of God,’ *Zygon* 39, no. 4 (2004): 815.

³⁵¹ Brueggemann, *Genesis*, 32.

³⁵² G. C. Berkouwer, *Man: The Image of God, Studies in Dogmatics* (Grand Rapids: Eerdmans, 1972), 69.

that is added afterwards. Driver appears to need no clues from the text when he says it can be ‘nothing but the gift of *self-conscious reason*’³⁵³ and then gives a list of many attributes which are included in this. Other commentators and interpreters do see some explanation given about the meaning of the image in the context. The reference to human beings having dominion is indeed at least part of what it means to be made in God’s image for ‘the dominion of humanity over creation can hardly be excluded from the content of the image itself.’³⁵⁴ If dominion is not included in the image but is a subsequent, in the next breath, commission for human beings from God, then the authority given is part of, and therefore images, God’s authority and it is difficult to see how the given authority is not part of the image itself. But if dominion is implicit in the image what is the point of the granting of it separately from the reference to creation in God’s image? The answer is that ‘let them have dominion over the birds ... etc.’ defines the area in which the human beings exercise the capacity for ‘dominion’ which is an essential part of their creation. The following command to be ‘fruitful and multiply, and fill the earth and subdue it’ then indicates a necessary condition to be fulfilled in order that the mandate be exercised.

It is one thing for a reader in the twenty-first century to understand the image of God in this way, but is that how it will have been understood when written? As shown above the immediate context certainly supports such an idea, but also the wider cultural background of the nations around Israel yields further affirmation. The practice of kings putting up statues (images) of themselves in vassal territories to represent their sovereignty over it is well documented and it is now ‘generally agreed that the image of God reflected in human persons is after the manner of a king who establishes statues of himself to assert his sovereign rule where the king himself cannot be present.’³⁵⁵ The expression ‘image of God’ has been discovered in ancient Babylonian texts referring to the King³⁵⁶ and also Egyptian texts speaking of Pharaoh in terms of being the image of a particular God, e.g. in the image of Re.³⁵⁷ The immediate contrast between the king as the image of God and humanity in general bearing that designation is glaring. From

³⁵³ S. R. Driver, *The Book of Genesis*, ed. Walter Lock, 5th ed., *Westminster Commentaries* (London: Methuen, 1906), 15.

³⁵⁴ Clines, ‘Humanity as the Image of God,’ 495.

³⁵⁵ Brueggemann, *Genesis*, 32.

³⁵⁶ Middleton, *The Liberating Image*, 111-18.

³⁵⁷ *Ibid.*, 108-11.

somewhere the author of Genesis 1 has found an idea that democratizes the image of God and thereby questions the authority of kings and, perhaps, priests to rule over people. The idea may be ancient as there has been found an Egyptian text of instructions for King Merikare which refers to people as the image of God:

‘Well tended is mankind – God’s cattle, ...
He made breath for their noses to live.
They are his images, who came from his body,
He shines in the sky for their sake
He made for them plants and cattle,
Fowl and fish to feed them.’³⁵⁸

However it must be noted that the idea of people being generated from God’s body is wholly foreign to the Old Testament, as is the identification of the sun as God, and the Genesis text speaks of an initial vegetarian diet for human beings. This text predates the reference to the Pharaohs as images of God, but around the time of the exile, when it is largely presumed Genesis 1 was composed, the focus was on the King. This is born out not only by the texts referred to above but also by the way Babylonian society had developed.

The official view expressed in documents such as the Atrahasis Epic and Enuma Elish was that ‘people were created to do the work the gods were tired of doing and to provide for the gods’ needs.’³⁵⁹ For instance in the latter text Marduk, following his victory over Tiamat and his creation of the universe, plans an extensive building project (Babylon) to be constructed by the rebel gods who sided with Tiamat. These gods express concern about the burden being put upon them and appeal to Marduk for relief. The God Ea put forward a solution which was to seek a scapegoat for Tiamat’s rebellion and for that god to be executed, his blood being used in the creation of humankind. Kingu, Tiamat’s consort, was nominated and duly executed so that Marduk could carry out his plan; ‘thereupon from his blood [he cre]ated mankind, imposed the service upon him, released the gods who must else have served.’³⁶⁰ This story does not simply function as presenting a theological idea about the creation of humans, it principally serves to place a rationale behind the actual social system that had developed into ancient Mesopotamian

³⁵⁸ Miriam Lichtheim, *Ancient Egyptian Literature: A Book of Readings*, vol. 1 (Berkeley: University of California Press, 1973), 106.

³⁵⁹ Walton, *Ancient Israelite Literature in Its Cultural Context*, 79.

³⁶⁰ D. Winton Thomas, ed., *Documents from Old Testament Times* (London: Thomas Nelson and Sons, 1958), 12.

civilization, for this story and others have ‘a clear ideological function, serving to legitimate the social role of vast numbers of human beings as vassals of the gods and servants of the temple and priesthood in ancient Sumer, Babylon, and Assyria.’³⁶¹

Within that cultural setting the king is spoken of as the image of God ‘whereby the king represents the god by virtue of his royal office and is portrayed as acting like the god in specific behavioural ways.’³⁶² This merging of religious and secular power in the person of the king relates clearly to the taking over of the temples and their estates, which were originally independent of the monarchy, by the king with the result that ‘if the purpose of the mass of humanity is to serve the gods and if the king represents those gods as their son and image, then the gods are served precisely by serving the king, who wills the present social order.’³⁶³ The consequence of all this was that the people of Israel experienced their eastern neighbours as ruled by kings who were the image of god here on earth and whose use of violence in carrying out the purposes of god was legitimated by their creation myths.

The writer of the creation story in Genesis 1-2:4b democratizes and universalises the image of God. It could be argued that this was a ‘false universality’³⁶⁴ not only in that it might be instinctively understood by the writer and first hearers as applying only to men, but also restricted to Israelite men. But this is not what the author says. It has to be noted that the image is specifically applied to both male and female in this first creation story which, with the Garden of Eden story which follows, leads into the stories and genealogies of the nations in general before the focus is fixed on Abram, who comes originally from Ur of the Chaldeans. This basic metaphor for understanding human beings ‘presents an equality in the image of God male *and* female, although the Bible overwhelmingly favors male metaphors for deity.’³⁶⁵ In modern western culture there is an immediate temptation to individualise the image and see every individual human being as bearing the image. The text does not say that but presents the image as corporately given to ‘them.’

³⁶¹ Middleton, *The Liberating Image*, 170.

³⁶² *Ibid.*, 121.

³⁶³ *Ibid.*, 173.

³⁶⁴ Marilyn J. Legge, ‘Colourful Differences: ‘Otherness’ and the Image of God for Canadian Feminist Theologies,’ *Studies in Religion. Sciences Religieuses* 21 (1992): 68.

³⁶⁵ Phyllis Trible, *God and the Rhetoric of Sexuality* (Philadelphia: Fortress Press, 1978), 22.

The exploration of the first creation story in Genesis has yielded an understanding of it as a 'form of ideological resistance to Mesopotamian traditions that devalued the status and role of humanity.'³⁶⁶ In saying this it has to be noted that the text is not at all argumentative in style or language, but rather it is 'undisturbed by polemic or dispute' and the controversial note is heard 'indirectly.'³⁶⁷ It is not having to arguing the case. As far as the author is concerned what he is writing is how things are understood to be. This leaves a problem in that it is divorced from the reality of everyday life. A description of creation which has ruled out violence and chaos from the eternally existing order may give some comforting background for life, but it does not engage with the difficulties of ordinary life as experienced, even in peaceful times, by the first audience let alone those additional problems of war and captivity. It is difficult to imagine this text existing without some form of counterpoint. This may, if it was heard in a liturgical setting, have been some of the psalms, but in Genesis as it stands the balancing of the opening creation story is achieved by the Garden of Eden story of chapters 2 and 3. This narrative focuses on the creation of human beings and their 'fall from grace'. It does not concern itself with the wider questions of the creation of the world and the perceived universe, but is focussed on explaining the background to the harsh realities of life.

Before turning to this narrative it is worth summarising the territory covered so far. Whatever the sources that have been used in writing this first creation narrative the outcome is a singular, coherent story which contrasts with the wider cultural background in significant ways. Creation is depicted as act of the one God who shares creative power and rule with what is created. God is neither compelled to create nor fight and defeat opposition in the process. In creating human beings God grants them the distinction of being 'in the image of God', that is the God who is a creator, granting them a domain in which to exercise dominion. The image is given to all people corporately, not just to Kings and not just to men. It can also be noted that in order to exercise dominion human beings will need to have some comprehension of the created order in which they are set. As has been shown in the previous chapter this is achieved by the human creative imagination constructing a mental analogue of reality. This analogue is the basis for the

³⁶⁶ Middleton, *The Liberating Image*, 235.

³⁶⁷ Cassuto, *A Commentary on the Book of Genesis*, 7.

further exercise of imagination which leads to ongoing creative activity in God's creation.

4.4 The Garden of Eden

Turning now to the Garden of Eden story (Gen. 2.4b-3.24) it can be noted that it is customarily attributed to a different author (J) from that of chapter 1 and scholars have perceived two underlying older stories that have been merged together to produce a single narrative. One story simply concerns the creation of human beings and takes in the initial creation of 'the man', placing him in a garden, unsuccessfully seeking a helper by the creation of the animals, but finally coming to a successful conclusion with the creation of a woman. The second story is about the expulsion from the garden after the human beings had disobeyed God and eaten the fruit of a particular tree which had been prohibited. The tree of life does not occur in either of the original stories and the other punishments listed in Genesis 3.14-19 are also additional to them. In order to mesh these stories motifs from the second are embedded in the first. So the reference to the tree of the knowledge of good and evil mentioned in Genesis 2.9 and the ban on eating its fruit, Genesis 2.17 are imported from the second story.³⁶⁸ Not all interpreters agree with this division because of the 'dramatic coherence'³⁶⁹ between chapters 2 and 3.

In the first half of the story the focus is on the creation of the human couple, the completion of which forms the climax of that part. This is similar to the creation of human kind in chapter 1, even though other details, such as the timing of the creation of plants and animals, are different. The idea that people were formed from the ground is a common theme in the ancient Middle East but it is usually clay that is referred to, perhaps thinking about the work of a potter, as in the 'Gilgamesh epic' and the creation of Enkidu by Aruru. She is instructed by the god Anu to create a man to counteract the troubling behaviour of Gilgamesh:

'When Aruru heard this,
she fashioned Anu's idea in her heart.
Aruru washed her hands,
she took a pinch of clay, she threw it down in the wild.
In the wild she created Enkidu, the hero.'³⁷⁰

³⁶⁸ Westermann, *Genesis 1-11: A Continental Commentary*, 190-96.

³⁶⁹ Brueggemann, *Genesis*, 40.

³⁷⁰ A. R. George, *The Babylonian Gilgamesh Epic*, vol. 1 (Oxford: Oxford University Press, 2003), 545.

The idea of imagination being at work in a creative act is lodged in this story. In Genesis 2 it is out of dust that the man is made which then links into the reference to dying in Adam's punishment, 'you are dust, and to dust you shall return.' (Gen.3.19)

Both creation stories in Genesis indicate that being in community is intrinsic to being human. It is not simply the creation of a man that is related but the creation of man and woman together that is a key issue for both stories. When put in the garden the man is told to till the ground and to keep it, or guard it, and the animals are brought to him for naming in the process of discerning if any would be a suitable partner and helper. All these activities can readily be seen as a 'paradigmatic form of organizing and transforming the environment into a habitable world for humans,'³⁷¹ i.e. part of the mandate to have dominion over the earth given to human beings in Chapter 1. Having dominion raises the question of how it is to be exercised, what is to be done with it? The first stage involves being able to comprehend God's creation. This in itself is a creative act as the picture of reality in our minds is the result of our imaginations working very effectively with sensory data. The next stage is to begin to order what is found. Human beings are here sharing in God's creative activity by being themselves creative, albeit initially in the naming of animals before a suitable companion, Eve, is found to help Adam in his exercising of dominion.

Recognising this coherence between the two creation accounts is not to claim any literary dependence of one text on the other, but simply to note that in this respect they are not at odds with one another. This should not be a surprise for, whatever the ultimate origin and history of the texts, in their final form they both relate to how one particular people viewed themselves. However the real point of the garden story is to provide an explanation of how it is that life is difficult and full of pain even at its most basic points of food provision and procreation. The expulsion from the garden does not seem to be the primary punishment for their disobedience for it is linked with the need to prevent the human couple from eating the fruit of the tree of life and so making opposition to God eternal, but it throws into relief 'that every human limitation is in the context of alienation from God.'³⁷² The nearest parallel account to this second story in Genesis is

³⁷¹ Middleton, *The Liberating Image*, 89.

³⁷² Westermann, *Genesis 1-11: A Continental Commentary*, 195.

the Adapa myth,³⁷³ fragments of which have been discovered in Egypt and at Nineveh. In this account, Adapa, a priest of Ea summonsed to appear before Anu the God of the heavens, is instructed by Ea as to how to curry favour with the gods and warned not to eat any food offered by Anu. Adapa is obedient to Ea's command, but the food offered is the food of eternal life. Adapa then, by his obedience, gains wisdom but loses the opportunity of immortality. How this relates to the Garden of Eden story is not entirely clear but it is perhaps too much to say 'the similarities are incidental and the differences primary.'³⁷⁴ In both cases wisdom is gained and immortality lost. In the case of Adapa it is a result of his obedience, but in the case of Adam it is through his disobedience.

There are two specific issues to be raised about the Garden of Eden story. The first is that God does not appear to carry out his threat to end the life of the man if he eats the forbidden fruit. One way of dealing with the issue is to interpret the threatened death as spiritual death, 'dying is separation from God.'³⁷⁵ This has the advantage of allowing the punishment to follow immediately after the offence without God intervening, as is shown by Adam and Eve hiding from God. If this were the case then there would be no need for further punishment, but rather an explanation of the present situation of alienation from God in terms of, 'now see what you have done'. The statement, 'I will greatly increase your pangs in childbirth' (Gen. 3.16), goes beyond this and so makes this suggestion unlikely. Kline seems to sidestep the problem by making death more significant following the act; 'Death, formerly present in nature in subservience to man, would now terrorize man the covenant breaker as the wages of his sin.'³⁷⁶ The best approach is to acknowledge that what God promised did not happen and the fact that it did not happen is significant to our understanding of God. 'The death penalty... is not really a threat; it is ... much more a warning. After the man and the woman have eaten from the tree, a new situation arises in which God acts differently from the way he had indicated.'³⁷⁷ Such an interpretation would fit with the idea that the non-fulfilment of the threat is a rhetorical device of the storyteller to get the listeners to reflect on the nature of God, and

³⁷³ James B. Pritchard, ed., *Ancient Near Eastern Texts Relating to the Old Testament*, 3rd ed. (Princeton: Princeton University Press, 1969), 101-03.

³⁷⁴ Walton, *Ancient Israelite Literature in Its Cultural Context*, 65.

³⁷⁵ Leupold, *Exposition of Genesis*, 128.

³⁷⁶ Meredith G. Kline, 'Genesis,' in D. Guthrie and J. A. Motyer (eds.), *The New Bible Commentary Revised* 3rd ed. (London: Inter-Varsity Press, 1970), 85.

³⁷⁷ Westermann, *Genesis 1-11: A Continental Commentary*, 225.

it also would fit with the idea, explored in a later chapter, of God having to work out the nature of divinity as creation responds to God in new ways.

The second issue is that of the cursing of the ground;

‘cursed is the ground because of you,
in toil you shall eat of it all the days of your life;
thorns and thistles it shall bring forth for you;
and you shall eat the plants of the field.
By the sweat of your face you shall eat bread
until you return to the ground.’ (Gen. 3:17-19)

The interpretation can be along the lines of God actively using the ground, ‘which hitherto had ministered to Adam’s welfare (*cf.* 1:29), as a medium of God’s judgement curse against him.’³⁷⁸ Another way of interpretation is that there is not only alienation between Adam and God but also between Adam and the ground. ‘Because he submitted to his wife, whereas he should have ruled, therefore he shall experience insubordination on the part of the soil.’³⁷⁹ A common feature of these approaches is the active participation of the ground in Adam’s punishment and that God is deliberately using the ground. Such an interpretation is not necessary because the curse is not in direct speech³⁸⁰. A better approach is to say that because Adam has, in disobedience to God, acted outside of his remit, the ground will suffer in that it will not be blessed with fruitfulness by Adam’s activity, but rather ‘thorns and thistles ... will grow and diminish the output and make the harvest difficult.’³⁸¹ This is because the human pair will be outside of the specially prepared garden environment and in the wider world which needs the work of human beings in order to be fruitful. Within the garden there was the opportunity to learn how to make the earth fruitful, but that is now lost. So not only are human relationships with God and the rest of creation damaged by the act of disobedience, but there is also ignorance on the part of the human beings as to how to carry out properly the task of tilling and keeping. In this way the earth is diminished and cursed. What God originally intended for creation has not happened. It is not too much to say that God took a risk with the creation of human beings. Creativity involves bringing

³⁷⁸ Kline, 'Genesis,' 85.

³⁷⁹ Leupold, *Exposition of Genesis*, 173.

³⁸⁰ Westermann, *Genesis 1-11: A Continental Commentary*, 264.

³⁸¹ *Ibid.*

into being that which is novel, the consequences of which are unknown because of the novelty. Creativity involves risk.

4.5 Beyond Eden

The opening creation story in Genesis and the following Garden of Eden story stand together in the present text in a form of counterpoint. Between them they speak of the one God, the perfection of creation with its exalted place for human beings, and the difficulties of life for those special creatures because of their disobedience. The first story needs the second to prevent it becoming impossibly idealistic, but also the second story needs the first to set the wider context which establishes the sovereignty of God over all of creation. No attempt is made to explain the origin of evil, other than speaking of human wilfulness in disobeying God. This question is effectively sidestepped for, whilst Adam and Eve are quizzed on their actions, the snake is not questioned but simply punished in a way that appears to be an explanation of the way snakes are. The placing of the two stories alongside each other allows connections to be made between them. But whilst the final redactor 'must have seen connections between the pieces of J and P that he arranged next to each other,'³⁸² we cannot be certain that what we see is what was seen. Nevertheless it is worth noting the way the 'image of God' from the first story is revealed in the 'tilling and keeping' of the earth and the naming of the animals in the second story. Also of significance is the fact that when the human couple are evicted from the garden the place they find themselves is the very place which, according to the first story, God intends them to occupy anyway, an intention reaffirmed, 'be fruitful and multiply, abound on the earth and multiply in it' (Gen. 9:7), to Noah and his family after the flood. This perspective alters the significance of the second story in that it adds the dimension of learning or training to the purpose of the garden. This opportunity is lost and so human alienation from the earth is a result of ignorance as well as the tendency to exploit it for perceived human benefit as illustrated by the eating of the forbidden fruit. This is not to argue that there really was a Garden of Eden but that the story reflects an ambiguity about the relationship of human beings to the world which includes ignorance of how it works and how best to treat it.

³⁸² Wenham, *Genesis 1 - 15*, xxxvi.

Following on from the Garden of Eden account the family history of Adam and Eve is traced out beginning with the birth of two sons whose exercise of the mandate to have dominion is shown in that ‘Abel was a keeper of sheep, and Cain a tiller of the ground.’ (Gen. 4.1-2). The continuing story bears witness not only to the growth of violence, the murders of Abel by Cain and of a young man by Lamech (Gen. 4.8, 23), but also to various aspects of human creativity. Three specific areas are mentioned. The first is the production of portable dwellings and the domestication of animals started by Jabal (Gen. 4.20), the second is the development of music and musical instruments by Jubal (Gen. 4.21), and the third is the beginning of technology and metallurgy by Tubal-cain (Gen.4.22). All three can be clearly understood in terms of the image of God mandate of Genesis 1 showing how human culture is related to the particular creation of human beings.

4.6 Broadening the Understanding of the Image

The understanding presented above has dwelt on a functional interpretation of the image of God as well as the consequences of not obeying God. Human beings are created to exercise dominion. This is not to say that God created human beings and then gave them a job to do adding any necessary extra qualities needed in order for them to do it for this would mean that to bear the image of God is additional to being human, whereas it is ‘explaining what the person is.’³⁸³ This understanding fits into the reading of Genesis 1 and also its location within the wider cultures of the other nations surrounding Israel. Westermann’s objection that the writer ‘could not possibly think of a human being as standing in the place of God on earth,’³⁸⁴ presupposes a particular kind of priestly authorship of Genesis 1. The contextual understanding of the image of God presented above challenges this part of the interpretive framework. Batto assumes a priestly writer but sees him also as the final editor who produced such a ‘sweeping and substantive’ revision that he may be properly regarded ‘as ‘the author’ of the Tetrateuch.’³⁸⁵ Landes goes further when he argues that ‘there is no compelling demonstration that the priests actually composed this story themselves or even left their unmistakable literary marks

³⁸³ Westermann, *Genesis 1-11: A Continental Commentary*, 157.

³⁸⁴ *Ibid.*, 153.

³⁸⁵ Batto, *Slaying the Dragon: Mythmaking in the Biblical Tradition*, 74.

upon it.³⁸⁶ Not only does Westermann's objection not stand but the foundations of that objection are called into question.

Westermann himself proposes an approach to the understanding of the image of God which treats the phrase as adverbial rather than adjectival, that is to say it qualifies the verb 'create' and not what is created. This is interpreted as meaning that 'the creator God decides to create something that is his own personal concern.'³⁸⁷ This approach calls into question the significance for God of all that has been created beforehand. It puts a supreme significance on the human beings but devalues the cosmos and is contrary to God's own verdict on creation: 'God saw everything that he had made, and indeed, it was very good.' (Gen. 1.31) The same thought underlies God rejoicing in the whole range of God's creation as depicted in Job 38-41, and the Psalmist doing likewise in, say, Psalm 104. Westermann's interpretation focuses on relationship for 'God has created all people "to correspond to him," that is so that something can happen between creator and creature,' and the model for this is found 'in the Sumerian and Babylonian texts' where 'people are related to the creator god as servants of the gods.'³⁸⁸ But this background is challenged by the writer of Genesis 1 for human beings are created to serve, in the manner of having dominion, the rest of creation, rather than providing for the needs of God; 'If I were hungry, I would not tell you.' (Psalm 50.12) This images God. God is depicted as looking out from Godself and creating a cosmos which is other than divine. Human beings are created to look out from themselves in caring for the rest of God's creation.

The focus on the relational aspect of the image of God is not unique to Westermann and when Hefner reviews the history of the interpretation of the term and divides it broadly into the 'common characteristic tradition' over against the 'relationship tradition', his own view is 'to side with those who hold that the *imago dei* refers to our relationship with God.'³⁸⁹ McFadyen proposes that the image be thought of as functioning not as a noun but as a verb, 'a way of speaking comprehensively about being in a relation with

³⁸⁶ George M. Landes, 'Creation Tradition in Proverbs 8:22-31 and Genesis 1,' in Howard N. Bream, Ralph Daniel Heim, and Carey A. Moore (eds.), *A Light Unto My Path*. (Philadelphia: Temple University Press, 1974), 289.

³⁸⁷ Westermann, *Genesis 1-11: A Continental Commentary*, 156.

³⁸⁸ *Ibid.*, 157-58.

³⁸⁹ Hefner, 'The Evolution of the Created Co-Creator,' 228.

God that is definitive of what it means to be human.³⁹⁰ The relational aspect of the image is crucial but that is no reason to assume that this rules out a common characteristic view. It does not have to be one thing or the other. Middleton contrasts the *representative* understanding, i.e. a cultic function, of the image of god in Egyptian culture with the *representational* view, i.e. exercising divine power, in Mesopotamian culture. But he argues effectively that the latter is also based on a *representative* understanding.³⁹¹ Function and essence cannot be separated to give one priority over the other. The same is true of the different views of the image of God in Genesis 1. The text is clear that it is God who has priority. The metaphor of the image of God combines the relational aspect, the common characteristic aspect, and the functional aspect. Both the relational and the function aspects need that of common characteristics. Attempts, therefore, to divide up human nature to locate that particular piece which can be labelled ‘the image of God’ are as misguided as any that suggest that in the Hebrew mind that same nature can be separated out into body, mind and spirit. ‘A trichotomistic human psychology is as little to be based on the Old Testament concepts as a dualistic one.’³⁹²

4.7 God, Creation and Christian Theology

The discussion above has shown an Old Testament view of God as the unopposed sole creator of the cosmos which God not only calls into being, but also calls upon to play a creative part in its own development. God shares creativity. Human beings, created with a particular relationship to God and with characteristics shared with God, have the special role in creation of representing and acting on behalf of God. They may properly be referred to as ‘created co-creators.’ This is not to downplay the importance of the rest of creation for ‘God saw everything that he had made, and indeed it was very good.’ (Gen. 1.31) Human kind, in the image of God, cannot be satisfied unless the rest of creation is being fruitful and flourishing, a situation to be brought about through human creativity. However the actual situation in the world does not match this lofty vision because human beings disobey God, attempting to be ‘creators’ rather than ‘created co-creators’, alienating themselves from God and the created order. Human beings find

³⁹⁰ Alistair McFadyen, 'Imaging God: A Theological Answer to the Anthropological Question?,' *Zygon* 47, no. 4 (2012): 919.

³⁹¹ Middleton, *The Liberating Image*, 118-22.

³⁹² Walter Eichrodt, *Theology of the Old Testament*, vol. 2 (London: SCM Press, 1967), 148.

themselves in a difficult world, cut off from the Creator, having to learn about how the world works whilst being unsure what it is for, and always tempted to reach for further knowledge and experience. This is the world that Christians understand as being redeemed by Jesus Christ. The first Christians saw beyond their own redemption and perceived that Jesus Christ was intimately involved with the original creation of what is being redeemed.

This can be seen from St John who started his Gospel with the words ‘in the beginning was the Word’ echoing God’s creative speech in the opening chapter of Genesis. This finds a resonance also with the ‘logos’ of Greek philosophy. It speaks of an underlying rationality to God’s creation which was so important to the development of modern science. But there is another theme in the Scripture that George Steiner picks out from ‘Job’, and that is the irrationality, as perceived by human beings, of creation that is expressed in God’s response to Job in an overwhelming vision of God’s creation. “‘Art for Art’ or, more exactly, “‘Creation for Creation’” displays its enormity, its festive impertinence to humanity.The refusal of the potter to hold himself accountable to the clay’³⁹³. There is indeed a rationality to creation, but it is God’s rationality of

‘guidance rather than control, of a natural order that contains within itself openness, rather than a rigid predictability, and emergent order rather than an imposed one. It connects Heaven and Earth into one created system, with humans at the same time special because they are invited to participate in the wisdom of understanding it, but in no sense central or preferred.’³⁹⁴

Such rationality may seem irrational to us at times but does call for our worship of the Creator.

Even though the Christian Church adopted for its own the canon of the Jewish Scriptures, including the Genesis accounts of creation, it had already begun to develop a Christ centred view of creation. So the Christian Doctrine of Creation begins with the Jesus Christ of the New Testament understood as the second person of the Trinity for it is Christology that ‘enables theology to hold together creation and redemption.’³⁹⁵ If these two events become separated then redemption may become narrowly anthropocentric or

³⁹³ Steiner, *Grammars of Creation*, 40f.

³⁹⁴ Tom McLeish, *Faith and Wisdom in Science* (Oxford: Oxford University Press, 2014), 144.

³⁹⁵ Colin E Gunton, 'Introduction,' in Colin E Gunton (ed.), *The Doctrine of Creation*. (London: T. & T. Clark, 2004), 4.

the human body become relatively unimportant. The relation of Christ to creation, which ‘was prior to any role in redeeming humankind,’³⁹⁶ was the focus of the thoughts of the ‘earliest Christians’ who asserted ‘the primacy and the activity of Christ in creation.’³⁹⁷ The mediating relationship of second person of the Trinity to the whole created order is not understood simply in terms of creative activity for it is even deeper in that ‘the eternal Son is not merely the ontic basis of the existence of Jesus in his self-distinction from the Father as the one God; he is also the basis of the distinction and independent existence of all creaturely reality.’³⁹⁸

In the New Testament the life and actions of Jesus Christ represent in some way the Kingdom of God. This is to be seen in his teaching and in the miracles of exorcism, healing and nature which bring forth the question, ‘Who is this? Even the wind and the waves obey him?’ (Mk. 4.41) But whatever drove the Gospel writers to depict Jesus as the master of the created order would have disappeared completely were it not for the resurrection of Jesus which was the ‘explosion powerful enough to launch the missile’³⁹⁹ of the Christian Church and its developing doctrines. Robert Jenson⁴⁰⁰ may see it as somehow inevitable that the primal Church borrowed ideas from contemporary Judaism to produce statements such as ‘He is the image of the invisible God by him all things were created’ (Col. 1.15f) but there is a strong sense of hindsight involved here which tends to smooth out history in the same way that science text books make the development of science almost inevitable and ignore the clash of ideas and strong emotions that occurred on the way.⁴⁰¹ Moule reminds us that the identification of Jesus, ‘the Nazarene who had been ignominiously executed – with the subject of this description is staggering.’⁴⁰² We will never know all the other ideas which were examined as ways of understanding Jesus Christ after the resurrection but discarded as inadequate. But what we can see is that out of the experiences of encountering Jesus and

³⁹⁶ Anna Case-Winters, 'Rethinking Divine Presence and Activity in World Process,' in Thomas Jay Oord (ed.), *Creation Made Free* Kindle ed. (Eugene, Oregon: Wipf and Stock, 2009), Loc. 1719.

³⁹⁷ R. S. Barbour, 'Creation, Wisdom and Christ,' in Richard W.A. McKinney (ed.), *Creation Christ and Culture*. (Edinburgh: T. & T. Clark, 1976), 31.

³⁹⁸ Wolfhart Pannenberg, *Systematic Theology*, trans. G. W. Bromiley, 3 vols., vol. 2 (Grand Rapids, Michigan: Eerdmans, 1994), 23.

³⁹⁹ Moule, *The Phenomenon of the New Testament*, 21.

⁴⁰⁰ Robert W. Jenson, 'Aspects of a Doctrine of Creation,' in Colin E Gunton (ed.), *The Doctrine of Creation*. (London: T&T Clark, 2004), 17f.

⁴⁰¹ Kuhn, *The Structure of Scientific Revolutions*, 136ff.

⁴⁰² C. F. D. Moule, *The Epistles to the Colossians and to Philemon*, ed. C. F. D. Moule, *The Cambridge Greek Testament Commentary* (Cambridge: Cambridge University Press, 1962), 58f.

the Holy Spirit as described in the New Testament an intellectual process was started that transformed the ideas of what God is like. 'It is the experience of a gracious God in the lives of faithful believers that eventually led to the construction of the doctrine of the Trinity.'⁴⁰³ This may seem like an unnecessary complication to the understanding of the being of God but not only has it come out of the Christian experience of God but it also proves to be useful in understanding the relationship of God to the created order.

The point is that God is singular but not solitary. Within the Godhead there are relationships of freedom and love which 'mediate difference in the personal particularity of otherness and unity in communion.'⁴⁰⁴ So God has no need to create the world and be bound in relation to it in order for relationship to be part of the divine experience. The same is true of love. God did not have to create an object in order to love, for love was already there within the immanent Trinity. This means that not only is there no necessity for God to create the world in order in some way to complement God's being, but also the contingency of the created order is preserved for the same reason. Creation comes out of the triune love of God which is constitutive of the being of God founded in 'the freedom of relationship of the persons of Father, Son and Spirit'⁴⁰⁵ and is neither arbitrary nor necessary. In creation the role of the Son and Spirit is rather more than being 'the hands of God'. When Irenaeus used this expression⁴⁰⁶ he was ruling out the need of God to use some form of intermediary, such as angels, to carry out the work of creation. It is not simply that the Father has an idea of creation and puts the Son and the Spirit to work in carrying it out. Such a view may seem to be implied in Vanhoozer's helpful use of speech act theory in which 'the Father is the Locutor, the Son is his preeminent illocution and the Holy Spirit is God the perlocutor.'⁴⁰⁷ However they are all, within the relationship of love that binds all three together, involved in the whole process that leads to the world coming into being and coming to fulfilment. That is

⁴⁰³ Ted Peters, *God as Trinity* (Louisville, Kentucky: Westminster/John Knox Press, 1993), 187.

⁴⁰⁴ Christoph Schwöbel, 'God, Creation and the Christian Community: The Dogmatic Basis of a Christian Ethic of Createdness,' in Colin E Gunton (ed.), *The Doctrine of Creation*. (London: T&T Clark, 2004), 157.

⁴⁰⁵ *Ibid.*, 158f.

⁴⁰⁶ Irenaeus, *Five Books of S. Irenaeus against Heresies*, trans. John Keble, *Library of Fathers of the Holy Catholic Church* (Oxford: James Parker, 1872), 364.

⁴⁰⁷ Vanhoozer, *Is There a Meaning in This Text?*, 457.

to say that ‘the God who has created and redeemed the world has done so from the love that constitutes the life of the Trinity.’⁴⁰⁸

The incarnation of Jesus Christ brings, by the action of the Holy Spirit, the Son into the created order as a real human being who suffers and dies and so carries our experience into the Godhead. He does this by, on earth, following the promptings of the Holy Spirit to be obedient to the will of the Father and in this way ‘the Spirit *enables this* part of earth to be fully itself, to move to perfection than to dissolution.’⁴⁰⁹ This cooperation between the Son and Spirit, which is carried through in a truly free human way through the life of Jesus Christ is part of the whole process of creation which will culminate in time with the bringing of the created order to its perfection. In the New Testament there are different grammatical tenses used to depict the role of Christ in creation. Not only is there the past tense, ‘all things came into being through him’ (Jn.1.3), but also the present, ‘he sustains all things by his powerful word’ (Heb.1.3), and the future tense, ‘his willset forth in Christ, as a plan for the fullness of time, to gather up all things in him,’ (Eph.1.9f) which brings eschatology into the picture. There is a real sense in which creation has not been finished but is continuing towards its perfection as intended by God at the outset, but sin, the fall and redemption are not a side show such that the end takes no account of them. The bringing of all things together under Christ includes all the products of human creativity, there are ‘diverse cultural riches to be brought into the Heavenly City’⁴¹⁰, brought to perfection by the action of the Holy Spirit. God’s action in creation, redemption and perfection is one, so it can be said that ‘redemption will determine creation’⁴¹¹ eschatologically.

But is God creative? That sees a strange question given that God is the creator of the world. If God is a creator then surely he is creative. At this point we meet the distinction between the immanent Trinity and the economic Trinity, the former is to do with the divine inner being and the latter with God’s relationship with creation. Gunton argues that whilst ‘the act of creation is not foreign’ to God’s immanent Trinitarian being ‘it is of the essence of God’s freedom-in-relatedness that he is not bound to create’.⁴¹² He is

⁴⁰⁸ Stanley Hauerwas, *With the Grain of the Universe* (London: SCM Press, 2002), 211.

⁴⁰⁹ Colin E Gunton, *Christ and Creation* (Eugene, Oregon: Wipf and Stock, 2005), 52.

⁴¹⁰ Richard J Mouw, *When the Kings Come Marching In*. (Grand Rapids: Eerdmans, 1983), 48.

⁴¹¹ Peters, *God as Trinity*, 178.

⁴¹² Gunton, *Christ and Creation*, 121.

opposing Zizioulas' understanding that 'in being the Priest of creation man is also a creator'⁴¹³ for this, he argues, makes our imaging of God to consist in creativity, something that is not a defining characteristic of God. What is being preserved here is the contingency of creation. It might not have happened. But for it to have happened there had to be a free choice on the part of God that it would. But such a free decision is also a creative one and in making it does God then add a particular quality, i.e. creativity, to the divine nature? A way through this is to look again at the relatedness of Father, Son and Holy Spirit that constitutes the Trinity.

Relatedness as a term on its own carries little meaning. I could toss three coins onto a table and then investigate the relations between them. There is a certain identity between them in that they all represent a monetary value, if not the same value, but in that case the relationships between their values could be examined, i.e. one might have twice the value of the other two added together. Their geometric relationship could be defined by measuring the distances between them. All these relationships are static and talk about the Trinity in terms of relationship can simply result in a static picture of God. Adding that the relationships are indeed those of love, as the scripture indicates, does not necessarily take us any further for it could simply mean that Father, Son and Holy Spirit are lost in rapt contemplation of one another. The clue comes from the understanding that the inner relationships of love that constitute the immanent Trinity are not static but dynamic and indeed are 'actions' which, as it were, spill over, by a free decision on the part of the Trinity, into the creative actions that result in the created order coming into being. 'God does not *become* active when he acts as the Creator, he *is* active in the immanent actions which constitute the triune divine life.'⁴¹⁴ As Pannenberg says:

'The action of the one God in relation to the world is not wholly different from the action in his Trinitarian life. In his action in relation to the world the Trinitarian life turns outward, moves out of itself, and becomes the determinative basis of relations between the Creator and the creatures.'⁴¹⁵

In other words creativity is an attribute of the immanent Trinity and as such it can form the basis of creativity being an aspect of the meaning of the expression 'image of God' as applied to human beings. However it would be wrong to regard the image as consisting

⁴¹³ John D. Zizioulas, 'Preserving God's Creation,' *King's Theological Review* 13:1 (1990): 5.

⁴¹⁴ Schwöbel, 'God, Creation and the Christian Community: The Dogmatic Basis of a Christian Ethic of Createdness,' 158.

⁴¹⁵ Pannenberg, *Systematic Theology*, 5.

solely of creativity at the expense of relatedness, as in Gunton⁴¹⁶, and freedom, as in Zizioulas.⁴¹⁷

4.8 Summary

In section 1.2 of the first chapter above it was stated that a theology of technology will have to demonstrate it has the resources to deal with the communal aspects of creativity found in technology as well as the individual ones. As shown above it is the doctrine of the triune nature of God that provides the necessary resources. This connects with the results of the exploration of the term ‘image of God’ carried out in the earlier section of this chapter which yielded an understanding of human beings as being created purposefully by God with the capacity to have a special relationship with God and a creative role to play within the development of God’s created order. Human creativity operates at a communal as well as an individual level because the God who is imaged is communal and creative. On this understanding Steiner’s worry about regarding as creative a work which has more than one author is misplaced.

However this way of interpreting human creativity as derived from and reflecting God’s creativity is not unproblematic. This is especially so when it is claimed that human creativity is intended by God to operate in a way that moves towards the fulfilment of the divine creative purpose. The essential problem is that human creativity, especially when expressed through the development of technology, has often had harmful consequences for human beings and the rest of the created order. The story of the Garden of Eden, as explored above, with its depiction of human beings being alienated from God because of their rebellion will furnish some of the explanation of this phenomenon. A deeper exploration is required into it because technology is so easily objectified and demonised in our culture it may be considered that the problem lies within creativity itself. This possibility of creativity having a dark side will be the subject of the next chapter in order to demonstrate that the problems originate outside of the gift of creativity itself. We will then move on to a consideration of a particular and complex outcome of human technological creativity, the city, which will allow us to move into considering the place of technology within the eschatological purposes of God.

⁴¹⁶ Gunton, *Christ and Creation*, 121.

⁴¹⁷ Zizioulas, ‘Preserving God’s Creation,’ 3.

Chapter 5

Creativity's Dark Side

In the previous two chapters it has been argued that being creative is a fundamental part of human activity and is a reflection of God's creativity. Seen in this light creativity is perceived as being 'good'. Indeed it is a 'must have' these days. The box containing the sand and water play table bought for our grandchildren carries labels saying 'imagination', 'creativity', and 'stimulates senses'. Good parents will want their children to have the opportunity to be creative because 'it is almost axiomatic that creativity is good'⁴¹⁸. In fact in recent years creativity has even been heralded as a 'panacea to cure the economic decline of Western Europe and America'⁴¹⁹ as politicians and others seek solutions to the many problems of our present age. It seems that we need imaginative and creative thinking to find new ways to rebuild economies and improve productivity and standards of living. 'The notion that creativity and innovation are ... drivers of positive, beneficial, and desirable change is entrenched in our collective consciousness' and 'are instinctively regarded as good.'⁴²⁰

Those making such claims for creativity might be more cautious if they remembered that at least part of the recent debacle in financial markets was caused by the creative use of the Black-Scholes equation⁴²¹ the development of which was regarded as sufficiently novel for Robert Merton and Myron Scholes to be awarded the Sveriges Riksbank Prize in Economic Sciences in Memory of Alfred Nobel 1997.⁴²² Creativity does not always produce beneficial results. No doubt the authors of the Black-Scholes equation did not envisage their work being used in the way it was and had no desire to inflict disaster and hardship on the world, but because creativity brings something new into the world an

⁴¹⁸ Arthur J Cropley, 'The Dark Side of Creativity,' in David H Cropley, et al. (eds.), *The Dark Side of Creativity* 1st ed. (New York: Cambridge University Press, 2010), 1.

⁴¹⁹ Lorraine Gamman and Maziar Raein, 'Reviewing the Art of Crime,' in David H Cropley, et al. (eds.), *The Dark Side of Creativity*. (New York: Cambridge University Press, 2010), 156.

⁴²⁰ David H Cropley, 'Malevolent Innovation,' in David H Cropley, et al. (eds.), *The Dark Side of Creativity*. (New York: Cambridge University Press, 2010), 341f.

⁴²¹ Ian Stewart, *The Mathematical Equation That Caused the Banks to Crash* (The Guardian, 2012 [cited 11th March 2013]); available from <http://www.guardian.co.uk/science/2012/feb/12/black-scholes-equation-credit-crunch>.

⁴²² *The Sveriges Riksbank Prize in Economic Sciences in Memory of Alfred Nobel 1997*, (Nobelprize.org, 1997 [cited 11th March 2013]); available from http://www.nobelprize.org/nobel_prizes/economics/laureates/1997/.

element of unpredictability is also introduced and the producer of a creative idea may have no control over what other people may do with it.

Such unintended harmful effects are one aspect of what can be termed the 'dark side' of creativity and many current day problems are attributed to it. 'The world is right now paying for the dark side of creativity and intelligence – through global warming, disappearance of the ozone layer, proliferation of nuclear weapons, terrorism, the increasingly uneven income distribution, and many other problems.'⁴²³ It is this negative aspect of creativity that will be examined in this chapter and the key question is whether this negativity is inherent in creativity or caused by other factors. Traditional psychological research into creativity has examined its subject under the headings of Process, Person, Product, and Press⁴²⁴ and these will be used here. It also needs to be stated that as the realm of creativity is so large the main focus here, consistent with the thesis as a whole, is on creativity in technology.

5.1 Process

Creativity has at its root the human ability to produce new ideas, to see new connections, or new possibilities. This may happen when someone is thinking about a particular problem or situation and when an idea is immediately perceived as relevant and taken on to a fruition which may be malevolent or benevolent. But the capacity to produce those new ideas is a feature of the human mind. How this happens is not fully understood but the cathedral model with a central nave and side chapels⁴²⁵ is a promising approach. In this model the mind starts, in evolutionary terms, as a single nave of general intelligence to which are added, but initially isolated from, side chapels of specialised intelligences, viz. technical, social, linguistic, and natural history. It is the development of language that allows 'cognitive fluidity'⁴²⁶ to occur in which the separate sections of the mind cease to be isolated from each other and metaphor arises in human thinking. This model is seeking to explain the development of the modern mind in which we find separate parts of the brain handling different functions in our lives. Language allows these different parts to interact and in this interaction the possibility of new ideas comes about.

⁴²³ Robert J. Sternberg, 'Dark Side of Creativity and How to Combat It,' in David H Cropley, et al. (eds.), *The Dark Side of Creativity*. (New York: Cambridge University Press, 2010), 327.

⁴²⁴ Cropley, 'The Dark Side of Creativity,' 6.

⁴²⁵ Stephen Mithen, *The Prehistory of the Mind* (London: Phoenix, 1996), 65-78.

⁴²⁶ *Ibid.*, 211.

As will be shown in the chapter on ‘The City’ it is the bringing to fruition of at least some of these new ideas that allowed human beings to begin to understand, exploit, and adapt their environment in ways that we now sum up as technology. In this it is important to be quite clear that ‘the capacity for ideation is separate from the uses of the ideas.’⁴²⁷ At one moment a person may generate a new idea which is used in a benevolent way and at the next moment in a malevolent way. So when we take the root of creativity as being the human ability to generate new ideas then it is quite correct to say that, ‘Creativity does not have a dark side.’⁴²⁸

Theologically this translates as saying that this capacity for ideation, this creativity is an integral part of being human created by God and it is good (Gen. 1.31). It still holds true if we gloss God’s creation of human beings with ‘through evolution’. But it is not as simple as that. Creativity involves processes like seeing things in a new light, or giving surprising answers, or opening up risk, which in one sense are neither good nor bad. But it can be argued that under certain circumstances these processes ‘lead more or less automatically to disruption and introduce intolerable levels of uncertainty’⁴²⁹ which will be regarded as bad. A particular set of such circumstances is the classroom where research has demonstrated that although teachers express admiration for creativity in theory ‘they often dislike it in practice.’⁴³⁰ The evidence that in the classroom there is an inherent dark side to creativity can be summed up by saying that ‘creativity

- Shakes the foundations of the received classroom order,
- Brings uncertainty for pupils (and parents),
- Questions the value of laboriously acquired knowledge and skills,
- Threatens loss of status and authority for teachers, and
- Weakens teachers’ self-image.’⁴³¹

One reason why this argument does not work is that a supreme value is given tacitly to certainty of knowledge, classroom order, and teachers’ status. Looking at the situation from a more ‘open’ perspective, which in itself has a strong relationship with

⁴²⁷ Mark A Runco, ‘Creativity Has No Dark Side,’ in David H Cropley, et al. (eds.), *The Dark Side of Creativity*. (New York: Cambridge University Press, 2010), 22.

⁴²⁸ *Ibid.*, 15.

⁴²⁹ Cropley, ‘The Dark Side of Creativity,’ 6.

⁴³⁰ Cropley, ‘Creativity in the Classroom,’ 298.

⁴³¹ *Ibid.*, 304.

creativity⁴³², considerably weakens the argument and adds the further thought that to understand creativity people have to be creative themselves. The problem of the dark side is not inherent in creativity itself but is a consequence of the unsettling impact of creativity on the status quo. As we shall see later this means we are dealing with ‘Press’ rather than ‘Process’. The argument also falls because it also fails to recognise the immaturity of the pupils in terms of their knowledge, social skills, and emotional development in understanding the effect of their behaviour on others. The dark side of creativity is not inherent in the fundamental process of ideation which lies at its heart. The dark side may be perceived when ideation interacts with the world in some way. Whether it is seen or not will depend on the observer’s perspective and this is also shown to be the case when attention is moved from process to product. Even if it had not been possible to demonstrate that creativity’s dark side is not an intrinsic part of the human ability to produce new ideas it would not have been fatal to the thesis that creativity is a good gift from God. It would then have been necessary explore the issue of theodicy, the way in which God’s creation has ‘from the first emergence of life been “very good,” in certain senses, and also “groaning in travail.”’⁴³³

5.2 Product

Product is what is produced creatively by the creative person. A product may be identified with the dark side, that is to say it is regarded as in some way harmful. But there are two circumstances in which this might happen. The malevolence of the product may be intentional on the part of the creative person or it may be a by-product, an unintended product. In this latter case what is produced appears ‘to be not only unanticipated but undesired.’⁴³⁴ So immediately with product we are faced with two different situations depending on the intentionality of the creator. This would suggest that creativity can be divided between positive creativity and negative creativity bearing in mind that ‘we also should differentiate negative creativity from unintended negative consequences of creativity intended to achieve positive ends.’⁴³⁵ Superficially this seems

⁴³² G. J. Feist, 'Influence of Personality on Artistic and Scientific Creativity,' in Robert J. Sternberg (ed.), *Handbook of Creativity*. (Cambridge: Cambridge University Press, 1999), 290.

⁴³³ Christopher Southgate, *The Groaning of Creation* (Louisville, Kentucky: Westminster John Knox Press, 2008), 132.

⁴³⁴ Florman, *The Existential Pleasures of Engineering*, 59.

⁴³⁵ Keith James and Aisha Taylor, 'Positive Creativity and Negative Creativity (and Unintended Consequences),' in David H Cropley, et al. (eds.), *The Dark Side of Creativity*. (New York: Cambridge University Press, 2010), 36.

to present a simple solution to understanding how it is that that we find creativity producing both good and bad effects, i.e., positive creativity occurs when well-intentioned people produce beneficial effects, having separated out the unintended negative consequences that occur, and negative creativity occurs when malevolent people produce harmful effects.

Nuclear weapons clearly represent the ‘dark side’ because of the immediate and subsequent damage caused by their use and the fear surrounding their potential use. When first detonated over Japan the people of that country would have regarded them along with the scientists and engineers of the Manhattan Project which produced them as representing the ‘dark’ side of creative science and technology. However others, especially U.S. soldiers anticipating a deadly invasion of Japan, ‘expressed gratitude for its assumed role in ending World War II quickly’⁴³⁶ Those directly involved in the creative process which produced the bombs experienced ‘wide ranging intellectual and personal challenge and excitement.’⁴³⁷ In other words it was a good and creative time for them. Subsequently Robert Oppenheimer, a central figure in the project, saw real possibilities for peace because of what had been developed. He argued that atomic energy was a new field in which there were few vested interests and so represented an opportunity for an international development agency which could, by its example, stimulate the setting up of international collaborative agencies in other fields.⁴³⁸ What appears to be a clear example of the dark side proves to be more complicated because the use of the term ‘dark’ depends on the perspective of the person using it. As David Hecht writes, ‘A value laden term such as “dark” has to be understood as a commentary on the reaction to the invention, not just the invention itself.’⁴³⁹

A further example of the importance of perspective is given in this consideration of nuclear weapons technology:

‘If this technology were used in future religious warfare where there will be untold carnage say between Pakistan and India, a nuclear war

⁴³⁶ David K. Hecht, 'Imagining the Bomb,' in David H Cropley, et al. (eds.), *The Dark Side of Creativity*. (New York: Cambridge University Press, 2010), 75.

⁴³⁷ *Ibid.*, 72.

⁴³⁸ *Ibid.*, 82-86.

⁴³⁹ *Ibid.*, 75.

there would kill hundreds of millions, the only perception we can be left with is that these technologies are truly the work of Satan.⁴⁴⁰

It is not clear why the scaling up of devastation from that which resulted when these weapons were first used on Hiroshima and Nagasaki results in the technology being deemed intrinsically satanic. Some system of values is in the background which dictates that nuclear weapons technology is satanic if its use involves in the killing of hundreds of millions of people but not so if only several hundred thousand people are killed.

Other technologies introduce further complications into how they are perceived because an individual product of technology may end up having multiple uses. The field of aviation provides ready examples because aircraft are used as weapons of war and have been turned on civilian populations, but they are also used to transport food and medical aid to famine and disease struck areas of the world. The Douglas DC-3 was designed as a civil airliner before the Second World War but over 10,000 of which were built during that war primarily for military purposes. At the end of the war large numbers of surplus military DC-3s were sold to the world's airlines⁴⁴¹ boosting the emerging passenger and freight operations the world over. Of course many crashed in service as they aged. For example in the two month period April-May 1958 DC-3s belonging to Aerovias Ecuatorianas, BEA, and Air France were involved in fatal accidents⁴⁴²

The DC-3 was the result of a history of creative technological advance in many areas including aerodynamics, airframe structures, engines, and metallurgy. Initially it was designed as a civil airliner so it can be regarded as the product of positive creativity, but then it was pressed into military service. Creativity producing military products is two edged as one side will regard them as positive but the enemy will regard them as negative. The aircraft then went back into civilian service after the war, but people were killed in accidents involving a number of these aircraft.

An even more dramatic example is that of the terrorist attacks in the USA on 11th September 2001 when the world was shown how a hijacked airliner could become 'the

⁴⁴⁰ Lawrence A Terlizese, *Trajectory of the 21st Century*, 1st ed. (Eugene, Oregon: Resource Publications, 2009), xxv.

⁴⁴¹ John Stroud, 'Airliner Evolution in the Postwar Era,' in Philip Jarrett (ed.), *Modern Air Transport, Putnam's History of Aircraft*. (London: Putnam, 2000), 11.

⁴⁴² David (ed.) Partington, 'Casualty Compendium,' *Air-Britain Archive* 1999, no. 2 (1999): 63f.

terrorist's cruise missile or bomber.⁴⁴³ What these examples show is that a simple categorising process is difficult to maintain when thinking about creativity in the field of technology because the focus could be on a particular artefact, for instance an aircraft, or the potentially varied purposes to which it is put, each of which can be seen as a product whose value depends on the perspective from which it is viewed. Some of the purposes and consequences of using a particular product may have been unintended by the original creators.

This problem is not confined to the world of aviation for when Karl Benz and Gottlieb Daimler pioneered the petrol engine and produced the first motor cars⁴⁴⁴ they will not have imagined that the consequences of their work being traffic jams, fatal accidents and pollution, though in the days of intensive horse drawn traffic in cities there were already many deaths and injuries along with congestion and pollution and 'much suffering endured by draught animals.'⁴⁴⁵ Modern-day Pollution is one of the unintended consequences of the 'events that began with the Industrial Revolution in England'⁴⁴⁶ and at times has been severe enough to prompt governments into action, often seeking technical fixes which have their own unintended consequences.

In the twentieth century many cities experienced pea-soup fogs often referred to as smog. In the 1950's following the British Clean Air Act 1956, which was consolidated with the 1968 Act into the 1993 Act⁴⁴⁷, dramatic improvements were made in air quality in cities in Britain through the control of the burning of coal both for domestic heating and for the commercial production of electricity. 'Pea-soup fogs all but disappeared and the incidence and severity of lung diseases declined.'⁴⁴⁸ However part of the solution was to build large chimneys on to power stations thereby venting the smoke and gaseous products of the combustion of coal higher into the atmosphere. Pollution was then carried to other places where it caused acid rain damaging the environment in unexpected ways. Another technical fix had to be thought up and that was to change the way coal was

⁴⁴³ Hallion, *Taking Flight*, 405.

⁴⁴⁴ Linwood Bryant, 'The Beginnings of the Internal-Combustion Engine,' in Melvin Kranzberg and Carroll W. Pursell (eds.), *Technology in Western Civilization*. (New York: Oxford University Press, 1967).

⁴⁴⁵ Donald Cardwell, *The Norton History of Technology*, ed. Roy Porter, *Norton History of Science* (New York: W.W.Norton & Company, 1994), 371.

⁴⁴⁶ McClellan III and Dorn, *Science and Technology in World History*, 363.

⁴⁴⁷ UK Government, *Clean Air Act 1993* (1993 [cited 15th March 2013]); available from <http://www.legislation.gov.uk/ukpga/1993/11/contents>.

⁴⁴⁸ Arnold Pacey, *The Culture of Technology* (Oxford: Basil Blackwell, 1983), 64.

burned in electricity generating power stations. The problem chemical sulphur was still released from the coal but contained in the ash by use of crushed limestone. So the effect of the creative technical fixes was to alter the location of the pollution or contain it in some way but not to eliminate its production.

A proposed technical fix for the problem of smog in cities where it was principally caused by the exhaust gases of car engines was to spray the organic compound DEHA (Diethylhydroxylamine) into the atmosphere when the conditions were such that smog would form. DEHA belongs to a class of compounds known as 'free-radical scavengers' and as such it would prevent the chemical chain reactions which result in the formation of Ozone and Nitrogen Dioxide. There was, among scientists, a strong reaction against the addition of another pollutant to the atmosphere but the proponents of the idea argued that a different technical fix, installing catalytic converters to the exhaust systems of automobiles, would also produce other pollutants and be vastly more expensive.⁴⁴⁹ The point here is that technical fixes were proposed rather than looking at underlying causes of the problem of smog such as 'the working hours that create commuter traffic congestion and the habitual use of automobiles rather than public transport.'⁴⁵⁰

These two responses to the problem of smog show the human tendency to go for technical fixes which may need further technical fixes to counter the side-effects of the first fix and the reluctance to go for a deeper questioning of the behaviour causing the problem. Such responses might be called 'short-termism' and this is the target of the analysis of Bernard Lonergan's thought by Terry Tekippe⁴⁵¹ reviewed in Chapter two above. Lonergan viewed science and common sense as partners 'and it is their successful cooperation that constitutes applied science and technology.'⁴⁵² But technology should not be identified with common sense because it is not a mundane exercise. Rather it involves imagination and creativity in a way which common sense does not. Common sense may seek to guide technology into seeking fixes for problems but 'the general bias of common sense prevents it from being effective in realising ideas, however appropriate and reasonable, that suppose a long view.'⁴⁵³ This is not to suggest that when common

⁴⁴⁹ Thomas H. Maugh II, 'Photochemical Smog: Is It Safe to Treat the Air?,' *Science* 193 (1976).

⁴⁵⁰ Pacey, *The Culture of Technology*, 44.

⁴⁵¹ Tekippe, 'Bernard Lonergan: A Context for Technology.'

⁴⁵² Lonergan, *Insight: A Study of Human Understanding*, 298.

⁴⁵³ *Ibid.*, 228.

sense turns to technology for answers those answers will be devoid of imagination and creativity, but that common sense will tend to seize on what it regards as the obvious solution.

This examination of technological product has reinforced the idea that the perspective from which an artefact or process is viewed is important when considering the issue as to whether it is good or bad. It is also shown that human nature in terms both of its 'dark side' and 'short-termism' plays an important role in this. However there is no evidence here that there is an intrinsically dark side to that basic creative ability possessed by human beings because the dark side has been shown to emerge in the interplay of this ability with the very complex world-wide society that human beings have created. However, there is still the possibility of an intrinsic dark side which is suggested by the popular myth of the 'mad scientist'. To examine this idea it is the next 'P', that of Person, to which we turn.

5.3 Person

In this context Person refers to the whole character, including the personality, motivation, and emotions, of the creative person. This is a very complex area of research so much so that it has been suggested that there should be 6 'Ps' under consideration with the Person heading split into Personal Properties, Personal Motivation, and Personal Feelings.⁴⁵⁴ In the context of technology an effective creative person is someone whose idea actually comes to fruition in a novel definable product. The product may be a tangible thing or an action, a process perhaps of achieving some goal as illustrated in the section on 'Product' above.

In the sections above on 'Process' and 'Product' it was argued that there is no inherent dark side to creativity when the fundamental aspect of ideation that is critical to creativity is in view. That did not take into account the possibility that this production of new ideas might be harmful to the individual thinking them, that is to say there may be a link between creativity and madness. In seeking to answer the question as to whether being creative is harmful to a person's mental health D. K. Simonton reviewed a body of research and, noting that 'the sheer act of creation can be a source of extreme stress,' initially concluded that the more exceptionally creative a person was 'the higher the odds

⁴⁵⁴ Cropley, 'Malevolent Innovation,' 344.

that the individual will endure substantial psychopathology.’⁴⁵⁵ This result is immediately subverted by his review of a different body of research which leads to the opposite conclusion. He notes that full-blown madness will prevent the appearance of creativity and that it has been shown that there is a ten year rule which indicates that ‘no person can expect to make world-class contributions to a domain without first devoting a full decade to acquiring the requisite knowledge and skills.’⁴⁵⁶

It has to be recognised that Simonton is specifically not dealing with everyday creativity but is seeking to cast light on the processes involved in creativity by examining those he terms ‘creative geniuses’. Such people are defined as those who ‘have secured a lasting reputation for their original contributions to human civilization.’⁴⁵⁷ It might be expected that people who are creative at this level, that is they are producing very significant new ideas in a particular field, might suffer from more psychopathology because they have to be dealing with other established people in that field who are reluctant to accept such novelty and may even be actively hostile to it. Elsewhere Simonton expresses some exasperation at the tendency for psychologists in the field of creativity to adopt polarised positions on issues commenting that if ‘physicists adopted the same *modus operandi*, they would still be arguing about whether light constitutes a wave or particle phenomenon!’⁴⁵⁸ He doesn’t say whether this exasperation causes him some psychopathology, seeing himself as a lone prophet voice proclaiming the truth of the Darwinian nature of creativity.

The conclusion he comes to is that ‘creative genius is both sane and insane. This may seem to itself constitute a totally mad response, but I do not think that it is possible to give another.’⁴⁵⁹ However in dealing with creative geniuses he is looking at more than the basic ability to create novel ideas and connections because such people will only have been recognised by their ability to produce effective ‘products’ in their particular domain. Such production involves more than new ideas for there will be an interaction involving

⁴⁵⁵ Dean K. Simonton, 'So You Want to Become a Creative Genius? You Must Be Crazy!,' in David H Cropley, et al. (eds.), *The Dark Side of Creativity*. (New York: Cambridge University Press, 2010), 224.

⁴⁵⁶ Dean K. Simonton, 'The Creative Process in Picasso's Guernica Sketches,' *Creativity Research Journal* 19, no. 4 (2007): 330.

⁴⁵⁷ Dean K. Simonton, 'Creativity from a Historiometric Perspective,' in Robert J. Sternberg (ed.), *Handbook of Creativity*. (Cambridge: Cambridge University Press, 1999), 116.

⁴⁵⁸ Dean K. Simonton, 'Picasso's *Guernica* Creativity as a Darwinian Process,' *Creativity Research Journal* 19, no. 4 (2007): 381.

⁴⁵⁹ Simonton, 'So You Want to Become a Creative Genius? You Must Be Crazy!,' 228.

the producer's own personality traits, the response of others in the same domain, and the wider community. This suggests that any insanity is linked to the on-going processes involved in creativity rather than to the basic process of generating new ideas.

This conclusion is backed up by a further consideration that if there were a definite link between creative ability and mental ill-health then it would be expected that this be equally evident across all domains of human research and endeavour. However what has been found is that 'geniuses in the natural sciences tend to be more mentally healthy than in the social sciences; geniuses in the social sciences, more so than those in the humanities; and geniuses in the humanities, more so than those in the arts'⁴⁶⁰ a progression indicating that those in engineering and applied science are the most sane. This demonstrates that it is the wider context in which creativity is exercised that is the cause of any mental ill-health that is found, especially as it has been found even in those domains that appear to favour the development of psychopathological symptoms there are a significant number of 'creative geniuses who show no mental illness of any kind during their entire lifetime.'⁴⁶¹

5.4 Press

The fourth 'P' of 'Press' refers to the 'social context'⁴⁶² in which the creative Person is involved in the creative Process to produce the creative Product. This context may be the immediate work situation of an engineer involving management and colleagues and/or it may be the wider social or cultural environment in which that engineer lives. For instance it has been shown that the government of the Soviet Union effectively caused scientists to engage in a biological weapons programme, even against their own principles, by manipulating the environment in which they worked.⁴⁶³ The focus of this section will be on two major technological disasters, the R101 airship crash and the Space Shuttle Challenger explosion, to illustrate the way in which this aspect of the dark side of technology can lead to failure.

⁴⁶⁰ Ibid.

⁴⁶¹ Ibid., 226.

⁴⁶² David H Croyley, James C Kaufman, and Arthur J Croyley, 'Malevolent Creativity: A Functional Model of Creativity in Terrorism and Crime,' *Creativity Research Journal* 20, no. 2 (2008): 105.

⁴⁶³ Maria N. Zaitseva, 'Subjugating the Creative Mind,' in David H Croyley, et al. (eds.), *The Dark Side of Creativity*. (New York: Cambridge University Press, 2010), 57-71.

5.4.1 R101 Airship Disaster

On 4th October 1930 the hydrogen filled R101 Airship left Cardington in Bedfordshire to travel to India and back on its first long distance flight. In a storm the following day the ship crashed and burned up in France killing 48 passengers and crew with just 6 survivors. The official report concluded that the outer fabric at the nose of the ship had torn, exposing the gas bag behind it to the wind. A catastrophic tear then caused that bag to deflate and the resultant loss of lift ultimately resulted in the ship crashing into the ground and catching fire.⁴⁶⁴ The following paragraphs give an outline of the context and background to this disaster.

Scheduled airline services began before the First World War with the founding in 1909 of Deutsche Luftschiffahrts AG which successfully flew thousands of passengers in airships before services stopped with the outbreak of that war.⁴⁶⁵ The airships were known as ‘Zeppelins’ after their designer Ferdinand Graf von Zeppelin the founder of the airline company.⁴⁶⁶ During and after the war some experience was gained in Britain with airships but it wasn’t until 1924 that the possibility of a serious approach to the development of airships was taken up in order to facilitate air communications through the British Empire. The wreck of the British R.38 airship in 1921 had shown the need to improve knowledge of aerodynamics and the forces that were imposed on the structure in both normal flight and especially in the variable situations of gusting winds. Two bodies, the ‘Airship Stressing Panel’ and the ‘Airworthiness of Airships Panel’, were set up and their work was then extended to an experimental programme of airship development which included the building of the R101 by the Air Ministry and the R100 by the Airship Guarantee Company (a subsidiary of Vickers). From the outset it was held that ‘considerations of prudence and safety be of paramount importance’ and the choice of two design teams ‘ensured competition in design and provided that a purely accidental failure of one ship should not terminate the whole programme.’⁴⁶⁷ These airships were to be significantly bigger than any of their predecessors and represented a step change in the technology involved.

⁴⁶⁴ John Simon, *R101: The Airship Disaster: 1930, Uncovered Editions* (London: The Stationery Office, c1999), 153f.

⁴⁶⁵ John Stroud, ‘The Evolution of Transport Aircraft,’ in Philip Jarrett (ed.), *Biplane to Monoplane*. (London: Putnam, 1997), 29.

⁴⁶⁶ Hallion, *Taking Flight*, 95-98, 268.

⁴⁶⁷ Simon, *R101: The Airship Disaster: 1930*, 16.

In the event the programme was terminated by the crash of the R101 even though the R100 had made a successful North Atlantic crossing to and from Canada in the course of its test programme. This vessel, which was built in remote Howden Moor in Yorkshire, had been designed by Barnes Wallis who employed Nevil Shute Norway as his Chief Calculator and they did not feel themselves to be in a straightforward competition with the team designing and building the R101. This was because, as a commercial concern, they operated under financial constraints not experienced by the other team which was part of the Air Ministry. A further reason was that the R101 team also had the job of checking over the work done up in Yorkshire but there was no independent checking of the design work being done at Cardington where the R101 was built. The official report on the subsequent crash of the R101 put it this way:

‘No doubt this situation sometimes resulted in the determining voice, in dealing with difficulties reported to the Air Ministry as arising out of the construction or flying of the R101, being that of the very people who were engaged in designing or flying the ship. There was less opportunity for securing an outside opinion or taking effective instructions from headquarters, than would be the case if the science of airships was more advanced or more widely studied’⁴⁶⁸

The R101 flew before the R100 and on its second test flight on October 18th 1929, which was carried off successfully, Lord Thompson, the then Secretary of State for Air, was a passenger. After the flight he ‘emphasised that his policy was “safety first”, and that as long as he was in charge no pressure would be brought to bear on the technical staff to undertake any flight until they were ready and satisfied that all was in order.’⁴⁶⁹ The significance of this statement was that in the autumn of 1930 there was to be an Imperial Conference in London and airships were being developed to aid communications and travel throughout the British Empire. Lord Thompson was keen to make a return trip to India by airship in time for that conference in order to demonstrate the potential of such vehicles.

The initial test flights were successful but the ship was considerably heavier than planned and her useful lift was only 35 tons as opposed to the design criterion of 60 tons which

⁴⁶⁸ Ibid., 75f.

⁴⁶⁹ Ibid., 49.

was to include fuel, crew, passengers, baggage, food, and water etc. This was a serious matter as there would be a gradual loss of hydrogen gas, the lifting agent, during a trip and that in hotter areas of the world, where much of the empire was, the amount of lift would be reduced anyway. As a result a programme of weight saving was introduced as well as adjusting the design to increase the lift. This involved allowing the gas bags which held the hydrogen to expand more within the structure of the ship than originally planned and inserting an extra bay in the ship for an additional gas bag. This was a major exercise involving cutting the ship in half and inserting the new section, a process which would change the structural and aerodynamic stresses experienced by the frame of the airship. The R101 set off for India without the full approval of the two independent consultants who were not given sufficient time or data to review the changes.⁴⁷⁰

Allowing the gas bags to expand more than originally planned also had a significant side effect. As the ship moved through the air, particularly in rough weather, they would come into contact with and rub against the structural frame within which they were housed incurring small punctures in the process. Some loss of hydrogen was expected but if the puncture holes joined up to become tears, or if the holes were towards the top of the bags, then the loss would become worse and potentially more serious. To alleviate the problem padding was applied to the framework to reduce the chafing.

As is common with engineering schemes, the changes meant delays. Lord Thompson had hoped to do the return trip to India over Christmas 1929. On July 14th 1930, following suggestions of further delays, he wrote; ‘I must insist on the programme for the Indian flight being adhered to, as I have made my plans accordingly.’⁴⁷¹ This statement contrasts sharply with his original ‘safety first’ approach. All this put pressure on the people responsible for declaring the ship safe for flight and the flight test programme was curtailed before it set out for India on 4th October 1930. As the official report states;

‘It is impossible to avoid the conclusion that the R101 would not have started for India on the evening of October 4th if it had not been that reasons of public policy were considered as making it highly desirable for her to do so if she could.’⁴⁷²

⁴⁷⁰ Ibid., 82-88.

⁴⁷¹ Ibid., 78.

⁴⁷² Ibid., 157.

It was the Captain of the ship who was ultimately responsible for accepting that it was ready to make the long and arduous trip to India. Sadly he was among the deceased as was the Secretary of State for Air. The report is diffident about ascribing blame but the evidence of Squadron Leader Booth, who had been the Captain of the R100, to the commission of enquiry summed up the situation;

‘I feel that their decision to leave, or their agreement to leave, at that time was biased by the fact of the Imperial Conference coming off, and the psychological moment in airships when they could carry the Secretary of State to India, and bring him back to time. It biased their judgment in agreeing to fly.’⁴⁷³

In Nevil Shute’s opinion there was a further factor besides the political pressure. He notes that because the R101 team were essentially part of the Air Ministry the press office regularly released information about their progress.⁴⁷⁴ This put pressure on the team who felt they had to succeed and not be beaten by Barnes Wallis and his team in Yorkshire. The final straw was the successful return flight to Canada by the R100 which meant that ‘they had to fly R101 to India or admit defeat, accepting discredit and the loss of their jobs. They chose to fly.’⁴⁷⁵

In its day the R101 was a major technological endeavour so test and safety programmes were drawn up in advance to ensure the airship had the best possible chance of completing its objective. As time became short because of the various delays the pressure of public policy and national prestige, not to mention the personal prestige of the Secretary of State for Air, resulted in shortcuts being taken with those programmes and matters disregarded which would ordinarily have called for proper engineering attention. The R101 disaster is a clear example of ‘Press’ being a significant factor in the failure of a creative technological enterprise. The same appears to be true of the destruction shortly after launch of the space shuttle ‘Challenger’.

5.4.2 Challenger Space Shuttle Disaster

On 28th January 1986 at 11:38 a.m. the Challenger space shuttle lifted off from the Kennedy Space Centre. Extra publicity surrounded the flight because the crew of seven included Christa McAuliffe, a civilian science teacher, who was to be broadcasting

⁴⁷³ Ibid., 103.

⁴⁷⁴ Nevil Shute, *Slide Rule* (London: Pan Books, 1968), 57.

⁴⁷⁵ Ibid., 115.

science lessons from space. Approximately 73 seconds after lift-off the liquid fuel tank to which the shuttle was attached exploded, destroying the shuttle.⁴⁷⁶ All the crew were killed. President Reagan instituted a Presidential Commission chaired by William P. Rogers⁴⁷⁷ to investigate the cause of the accident and later in the year The House of Representatives launched its own investigation chaired by Don Fuqua.⁴⁷⁸ Citations from the Rogers' Commission Report are from the shorter version on the NASA website on a page by page basis for simplicity. The Rogers' Commission included Richard Feynman a Nobel Prize winning physicist.

The cause of the accident was a failure in the joint between the two lower segments of one of the Solid Rocket Motors. 'The specific failure was the destruction of the seals that are intended to prevent hot gases from leaking through the joint during the propellant burn of the rocket motor.'⁴⁷⁹

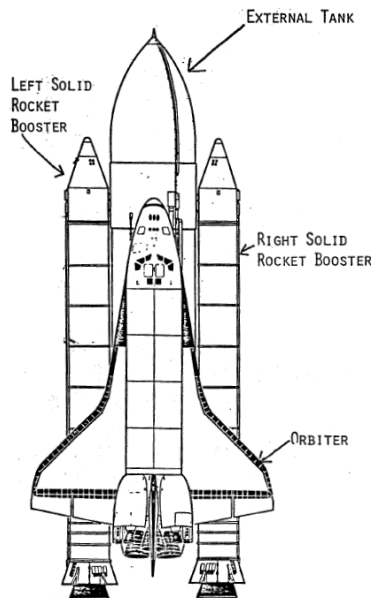

Fig.5.1. General Arrangement of a Space Shuttle at launch
From: Fuqua (Chair), 'Investigation of the Challenger Accident'

This had allowed the hot gases caused by the combustion of the solid propellant to vent as burning flame through a joint as well as the nozzle. This flame was directed onto the external tank carrying the liquid fuel, hydrogen and oxygen, used to power the shuttle's rocket motors during the launch. The result was an explosive conflagration which destroyed the shuttle. Figs.5.1 and 5.2 are presented to facilitate understanding of the arrangement.

The Shuttle was attached to the external tank with the fuel fed to the Shuttle's rocket motors during launch. The Shuttle detaches from the tank when the fuel is exhausted.

On either side of the external tank is a solid rocket booster, so called because the propellant is in solid form like in a firework rocket. When the propellant is ignited it

⁴⁷⁶ William P. Rogers (Chair), *The Accident* (NASA, 1986 [cited March 25th 2013]); available from <http://science.ksc.nasa.gov/shuttle/missions/51-l/docs/rogers-commission/Chapter-3.txt>.

⁴⁷⁷ William P. Rogers (Chair), *Report of the Presidential Commission on the Space Shuttle Challenger Accident* (NASA, 1986 [cited March 25th 2013]); available from <http://history.nasa.gov/rogersrep/genindex.htm>.

⁴⁷⁸ Don Fuqua (Chair), 'Investigation of the Challenger Accident,' ed. Committee on Science and Technology of the House of Representatives (Washington: U.S. Government Printing Office, 1986).

⁴⁷⁹ William P. Rogers (Chair), *The Cause of the Accident* (NASA, 1986 [cited March 25th 2013]); available from <http://science.ksc.nasa.gov/shuttle/missions/51-l/docs/rogers-commission/Chapter-4.txt>.

forms a highly pressurised hot gas exhaust which is forced through the nozzle at the bottom aiding lift off. When the propellant is used up the boosters are detached from the external tank and descend on parachutes so that they may be retrieved, refurbished and reused. Most of the thrust at launch is provided by the solid rocket boosters.

These boosters are made up in sections as shown in Fig.5.2 below. Some sections are joined together at the factory and the resulting segments are loaded with propellant before going to the Kennedy Space station for final assembly when the ‘field joints’ are made and sealed.

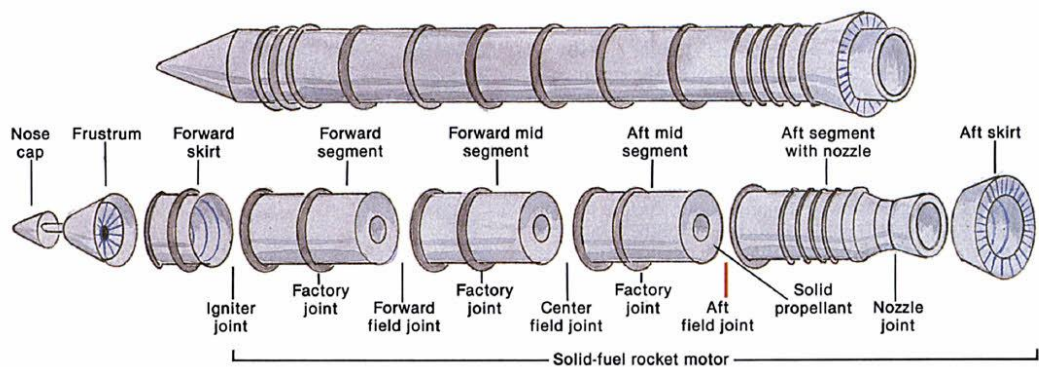

Fig.5.2. Make-up of a Solid Rocket Booster
From: Bell & Esch, ‘The Fatal Flaw in Flight 51-L’

The aft field joint labelled in the diagram is the one which failed on one of the booster rockets. The field joints were based on the successful joints used in the Titan III segmented rocket⁴⁸⁰, but that rocket was not intended to be re-usable. It had been anticipated that when the booster was firing and the casing put under internal pressure the joint seals, major components of which were a pair of O-rings made of a rubber-like material, would act in such a way to seal more effectively. Tests carried out in 1977 showed that on pressurisation the joint actually opened up, a movement that became known as ‘joint rotation’⁴⁸¹, making the O-rings potentially ineffective. This design problem was not addressed leading the Fuqua Report to conclude that ‘the fundamental problem was poor technical decision-making over a period of several years by top NASA and contractor personnel.’⁴⁸²

⁴⁸⁰ Trudy E. Bell and Karl Esch, ‘The Fatal Flaw in Flight 51-L,’ *Spectrum, IEEE* 24, no. 2 (1987): 40.

⁴⁸¹ Ibid.

⁴⁸² Fuqua (Chair), ‘Investigation of the Challenger Accident,’ 4f.

The solid rocket boosters were inspected following recovery after a launch. One of the engineers recorded that in January 1985 he found that ‘hot combustion gases had blown by the primary seals on two field joints and had produced large arc lengths of blackened grease between the primary and secondary seals.’⁴⁸³ There was also evidence that the hot gases eroded the primary seal. NASA effectively concluded that as the flights that exhibited these problems on post-flight inspection had launched successfully then the system was safe for future launches. Commissioner Feynman commented on the illogicality of this approach, ‘The O-rings of the Solid Rocket Boosters were not designed to erode. Erosion was a clue that something was wrong. Erosion was not something from which safety can be inferred.’⁴⁸⁴ He graphically likened NASA as playing Russian roulette not realising ‘the fact that the first shot got off safely is little comfort for the next.’⁴⁸⁵

After analysing their data some engineers at Morton-Thiokol, the contracting company responsible for the solid rocket boosters, sensed that when the O-rings were cold they would not expand to fill the enlarged gap at ‘joint rotation’. On the evening before the shuttle was due to launch, knowing that the overnight temperature at the launch pad was going to be well below freezing, they presented their concerns to NASA. Initially they had the backing of their management which did not recommend launching. This dismayed the NASA officials who then reinterpreted the data as being inconclusive. Under this pressure the management at Morton Thiokol took off their engineering hats and put on management ones, reversed their decision which they relayed to NASA who accepted it without question, despite the earlier position.⁴⁸⁶ The Rogers Commission ‘concluded that the Thiokol Management reversed its position contrary to the views of its engineers in order to accommodate a major customer.’⁴⁸⁷ The Fuqua Report puts the matter more directly,

⁴⁸³ Roger Boisjoly, *Pre-Disaster Background (Ethical Decisions - Morton Thiokol and the Challenger Disaster)* (National Academy of Engineering, 1987 [cited March 26th 2013]); available from http://www.onlineethics.org/Topics/ProfPractice/PPEssays/thiokolshuttle/shuttle_pre.aspx.

⁴⁸⁴ Feynman, ‘Richard P. Feynman’s Minority Report to the Space Shuttle Challenger Inquiry,’ 156.

⁴⁸⁵ *Ibid.*, 155.

⁴⁸⁶ Roger Boisjoly, *Telecon Meeting (Ethical Decisions - Morton Thiokol and the Challenger Disaster)* (National Academy of Engineering, 1987 [cited March 26th 2013]); available from http://www.onlineethics.org/Topics/ProfPractice/PPEssays/thiokolshuttle/shuttle_telecon.aspx.

⁴⁸⁷ William P. Rogers (Chair), *The Contributing Cause of the Accident* (NASA, 1986 [cited March 25th 2013]); available from <http://science.ksc.nasa.gov/shuttle/missions/51-l/docs/rogers-commission/Chapter-5.txt>.

‘The initial response of Marshall [NASA Space Centre] managers to the attempts of Thiokol engineers to raise the issue of temperature effects on the SRM seals caused Thiokol management to discount proper technical concerns and engineering judgment in their recommendation to launch.’⁴⁸⁸

The Rogers’ Commission concluded that the ‘extensive and redundant safety program comprising interdependent safety, reliability and quality assurance functions’⁴⁸⁹ which had been a feature of the Apollo programme with its lunar landings had ceased to function. The Fuqua Report found that the reason for this was that NASA was attempting to achieve 24 flights per year and this created internal pressures contributing directly to unsafe launch operations. It also acknowledged that the Committee on Science and Technology of the House of Representatives, ‘the Congress, and the Administration have played a contributing role in creating this pressure’.⁴⁹⁰ Challenger was not destroyed because there is something bad about creativity and its ensuing technology but because the ‘Press’ of the whole context distorted the approach of engineers and managers to the project.

It is of interest to note that Richard Feynman was the only scientist and independent member of the Rogers’ Commission. As he was not a specialist in the processes of the Space Shuttle programme he made it his business to talk to the engineers in order to understand what was involved. In this he brought to bear that same imagination and creativity that won him his Nobel Prize for Quantum Electrodynamics Theory. He also used these qualities to devise a simple but telling public experiment to demonstrate what had gone wrong with the booster rocket.⁴⁹¹ Creativity is needed in order to understand and critique a creative enterprise such as technology. Common sense cannot understand creativity because the latter always involves an element of novelty which will be alien to the assumed understanding of reality which underlies common sense. Technology is about human endeavour to change the environment in which we live and is a proper object of study for Theology. To deal effectively with technology Theology will itself need to deploy imagination and creativity in the understanding of this subject and itself.

⁴⁸⁸ Fuqua (Chair), 'Investigation of the Challenger Accident,' 11.

⁴⁸⁹ William P. Rogers (Chair), *The Silent Safety Program* (NASA, 1986 [cited March 25th 2013]); available from <http://science.ksc.nasa.gov/shuttle/missions/51-l/docs/rogers-commission/Chapter-7.txt>.

⁴⁹⁰ Fuqua (Chair), 'Investigation of the Challenger Accident,' 3.

⁴⁹¹ Jeffrey Robbins, 'Introductory Note to 'Richard P. Feynman's Minority Report to the Space Shuttle Challenger Inquiry.',' in Jeffrey Robbins (ed.), *The Pleasure of Finding Things Out*. (London: Penguin Books, 2001), 151f.

5.4.3 The Result of External Pressure

Both the British Government Airship initiative and the U.S. Government Space Shuttle programme were bold, imaginative and creative technological attempts to achieve specific benefits. In this chapter a disproportionate amount of space has been given to an examination of why they went wrong because, in both cases, it can be seen clearly that the external pressures had a detrimental effect on the projects. But such pressures, such as timescale and cost control, are not part of the creative technological process itself even if they are necessarily present as far as the commissioning agency is concerned. They will always be there with such projects whether financed by government or private enterprise and will constrain the creativity of engineers. This aspect of the dark side is separate from the creative ability of the technologists who are subject to these pressures which will be caused by the expectations of those commissioning a project.

5.5 Summary

Being creative is fundamental to being human. Without it there would be no science, including the psychology of creativity, or technology and human beings would be at the mercy of whatever changes occurred in the environment around us. With it we have begun to understand and transform our environment. As that process has continued it has become evident that sometimes there are unintended harmful consequences of technological action as well as technology being used deliberately to cause harm. These are a result of a heady mix of ignorance, sin, and will-to-power. Ignorance is not necessarily wilful for ‘even if the laws of physics are strictly deterministic’ there is still room for ‘unforeseeable novelty’⁴⁹² and dynamic systems in nature can be so sensitive to initial conditions that they are ‘essentially unpredictable.’⁴⁹³ In a technology such as aviation engineers seek to structure their designs and operating environments so that they remain within the boundaries of predictability. However engineers are finite beings with finite knowledge and even with extensive testing there is always the possibility of unexpected design failure, not to mention the unforeseeable responses of other human beings to their designs. So it is that the unintended effects of creative technology are generally related to a lack of knowledge linked to short-termism. However it has been

⁴⁹² Paul C. W. Davies, *The Cosmic Blueprint* (London: Heinemann, 1987), 31.

⁴⁹³ *Ibid.*, 53.

established that the harmful effects of human creativity are not a consequence of the fundamental human ability to produce new ideas. This means that this basic creative ability can be interpreted theologically as a gift to humanity from God, an aspect of being created in the image of God. This still leaves the question as to whether this gift is only to be exercised in the world as we currently know it with no eternal significance for the ultimate purposes of God's new creation. This question brings us to the next chapter in which an examination of the man-made city, a complex creation of interlocking technologies, leads us into an appreciation of the place of technology within God's purposes.

Chapter 6

The City

In previous chapters it has been argued that human imagination and creativity, which underlies all human knowledge and culture, is a good gift from God. This has been granted so that human beings can participate in the ongoing creative work of God. Given the destructive results of many human endeavours, the ‘dark side’ of creativity, there is a lingering doubt that in the end there will be no place for it in the eternal purposes of God. In other words human creativity and technology is only for this world as we know it and has no eternal significance except that God’s back is turned on it. In the closing chapters of the book of Revelation a city, New Jerusalem, features centrally in the vision of God’s new heaven and new earth. This opens up an understanding of a greater significance for human technology in that it is seen to make a genuine creative contribution to God’s purposes. Human technology finds its place in the heart of God’s New Creation. In this chapter the origins of cities from a historical anthropological viewpoint will be investigated followed by a consideration of recent attempts to develop a scientific understanding of them. The importance of cities in the modern world having been demonstrated, the perspective then shifts to examine the ambiguous place of cities in the Biblical narrative and the place they have in God’s purposes.

6.1 Paleolithic beginnings

Technology did not start with the cities, even though they are dependent on technology. The process by which humankind has transformed its environment began in the distant past of the Paleolithic Era. Indeed if pre-human apes had developed the skills shown in more recent years by, for instance, Chimpanzees and Japanese macaques⁴⁹⁴ then the start of technology really would be lost in evolutionary history. It appears that early humans created hand axes and ways of chipping flints to make blades and arrow heads and ‘with the development of the spear-thrower and the bow, man the technologist began to win his long struggle for human supremacy by matching skill against animal strength.’⁴⁹⁵ Even with the development of these and other tools, the mastery of fire, the building of the first

⁴⁹⁴ McClellan III and Dorn, *Science and Technology in World History*, 8.

⁴⁹⁵ T. K. Derry and Trevor I. Williams, *A Short History of Technology*, 1st ed. (London: Oxford University Press, 1970), 4.

houses and shelters with fireplaces, the beginnings of trade and art, tracking the moon and burying their dead, *Homo Sapiens* remained hunter gatherers in the Paleolithic era.⁴⁹⁶

It may seem to us that these beginnings were small and primitive compared to what we have achieved with global communications, space flight, intensive farming, factory-produced goods, 3D printing etc., but it was the product of the same capacity that continues to drive us. That capacity is human creativity which is based on imagination. As Hefner has put it, ‘the first stone tool was the product of the imagination, of the picturing the non-existent into existence, the skinning of a mammoth or the scaling of a fish.’⁴⁹⁷ That ‘picturing of the non-existent into existence’ would have been lost as dreams of fantasy had it not included a sense of what the imaginer could do in bringing the ‘non-existent into existence’. Whether the sequence in which the various parts of this imagining happened once only and in one place only or in different places and at different times is now lost to us in the mists of time, however we can see that even at this early stage of human creativity there arises the possibility of Boden’s P and H creativities⁴⁹⁸ in the process.

How it happened is not now important. What was really important is that the knowledge was not confined to one or more separated individuals. It formed part of Paleolithic culture. The knowledge of how to make and use that early hand tool was passed on. One person could see what another was doing and imitate it, indeed one person could imagine teaching another, a child or other family member perhaps, so enhancing the value of the skill or tool. But for progress to be made it has to be possible for someone who did not have the original idea to be able to imagine an even better way of doing something. When Bernal argues that a tool must be ‘*standardized by tradition*’⁴⁹⁹ so that its making and use can be passed on and progressively improved he is in danger of overstating the case because tradition can be a great inhibitor of creativity. For new things to be allowed there has to be openness to other possibilities. Our need for security and confidence in what we know leads to the valuing of tradition and if that valuing is too strong then creativity, which might threaten tradition by bringing about something new to culture, will be stifled. There is a tension here between the discovery that ‘a long period of time

⁴⁹⁶ McClellan III and Dorn, *Science and Technology in World History*, 9.

⁴⁹⁷ Hefner, *Technology and Human Becoming*, 45.

⁴⁹⁸ Boden, *The Creative Mind*, 43.

⁴⁹⁹ J. D. Bernal, *Science in History*, 2nd ed. (London: Watts, 1957), 38.

in a domain seems to be a necessary.... condition for notable contribution'⁵⁰⁰ and evidence suggesting that the more a person knows the less creative they become.⁵⁰¹ Knowledge exists within a mental framework of understanding which relates to the world. The more rigid and fixed that framework is so the possibility for creativity is reduced, but the framework, conceptual space, has to exist for it to be transformed to incorporate new ideas.

The making and using of hand tools and also the teaching of the making and using of such tools was certainly not the only creative cultural development in Paleolithic society. The beginning of speech and language was happening at this time. Palaeontologists are not certain about how or when they all began 'but, once acquired, the ability to convey information and communicate in words and sentences must have been an empowering technology that produced dramatic social and cultural consequences for humanity.'⁵⁰² Once an object, an action or a quality is afforded its own particular sound or sequence of sounds then life for an individual embraces more than the immediate and concrete reality. Words are not only spoken but also they are heard in the mind, recalled from memory. Sequences of events can be recalled or imagined in verbal ways as well as visual. Plans of action, strategies for finding food and shelter can begin to come into existence and when there are others who share that language then more complex plans can be worked out, success shared and boasted about, and tradition and culture can begin to be laid down. Gorringer is certainly correct to doubt that 'hunter gatherers did not plan.'⁵⁰³

Physical gesture no doubt preceded and has continued alongside speech and language so 'language, by gesture and voice ensures both the coherence of society and the handing on of its accumulated culture to later generations.'⁵⁰⁴ However, verbal language has been the more powerful of the two and opened up the possibilities of a far greater creative encounter with our environment. One reason for this is that, using the analogy of computer memory, more space is required to hold an image of a page of text than is required if it is stored as text in, say, a Word document. It takes more brain capacity to

⁵⁰⁰ Weisberg, 'Creativity and Knowledge: A Challenge to Theories,' 232.

⁵⁰¹ Ibid., 229.

⁵⁰² McClellan III and Dorn, *Science and Technology in World History*, 9.

⁵⁰³ Timothy Gorringer, 'Salvation by Bricks: Theological Reflections on the Planning Process,' *International Journal of Public Theology* 2 (2008): 102.

⁵⁰⁴ Bernal, *Science in History*, 39.

manipulate images than words. But language is not simply about allowing the brain to work more efficiently. It stimulates the ‘cognitive fluidity’⁵⁰⁵ which is an element in the creative ‘transformation of conceptual spaces’.⁵⁰⁶

Language is also important in the development of human memory. Evolutionary psychologists argue that the time period since the Stone Age has been too short for significant changes to the basic genetic coding of our brains to have occurred to allow our adaptation to modern times. It is language and communication that have ‘transformed the capacity and complexity of human memory’⁵⁰⁷ and technology has been used to provide extensions to human memory, a process which began in the Paleolithic era with what can be regarded as the beginning of science.

It should be noted that ‘to whatever small extent we may be able to speak about “science” in the Paleolithic, Paleolithic technologies clearly were prior to and independent of any such knowledge.’⁵⁰⁸ However the beginnings of what we call science are visible in terms of recordings of particular observations made of the world around them by Paleolithic humans. In a cave at Abri Blanchard in the Dordogne region of France an engraved bone fragment discovered in 1915 has been interpreted as ‘one of the earliest tallies of time’s passage, a two-month record of passing lunar phases.’⁵⁰⁹ Similarly an engraved mammoth tusk from Gontzi in Ukraine shows a cycle of four lunar months perhaps because ‘dispersed groups might have come together seasonally and would have needed to keep track of the intervening months.’⁵¹⁰ What has happened here is that human imagination has led to a creative technological way of making records of observations of the moon, perhaps because of a subconscious awareness of the pattern of the lunar cycle, and with the information now held in a visual way patterns will have been identified and made use of. Moreover the information can be passed on, taught, to someone else. This outsourcing of memory has been continuing ever since, the written word, maps and the phonebook on your mobile phone are good examples, and with the

⁵⁰⁵ Mithen, *The Prehistory of the Mind*, 215.

⁵⁰⁶ Margaret A. Boden, ‘Precis of the Creative Mind: Myths and Mechanisms,’ *Behavioral and Brain Sciences* 17, no. 3 (1994): 519.

⁵⁰⁷ Cohen, ‘Overview: Conclusions and Speculations,’ 383.

⁵⁰⁸ McClellan III and Dorn, *Science and Technology in World History*, 13.

⁵⁰⁹ Adam Frank, *About Time* (Oxford: Oneworld Publications, 2012), 4.

⁵¹⁰ McClellan III and Dorn, *Science and Technology in World History*, 14.

advent of the internet and Google it continues apace and affects the way we use our minds⁵¹¹.

6.2 Neolithic developments

For nearly 200,000 years the Paleolithic culture of hunter-gatherers had developed slowly and then towards the end of that period, at approximately 10,000 BCE, human beings began to build settled communities based on farming so beginning what we call Neolithic culture. Instead of hunting animals they herded them and instead of gathering what was available by way of fruit and berries they planted crops. As we look back using the ‘telescope of the imagination’⁵¹² it may seem inevitable that things developed this way.

‘When a hominid chipped a stone with the intention of making it into a more serviceable tool, this historic act, performed perhaps two million years ago, made it certain that, one day, some species of the same genus of the hominid family of primate mammals would not merely affect and modify the biosphere, but would hold the biosphere at its mercy. This mastery over the biosphere has been achieved, in our time, by *homo sapiens*.’⁵¹³

However ‘retrospect lends the evolutionary process the appearance of inevitability’⁵¹⁴ so we must be careful lest our perception of historical inevitability prevents us from seeing the many different, interlocking, and contingent creative acts that were involved in the process. The development of crops was not ‘a single act, but a step-by-step accumulation of interlocked inventions all subservient to the essential achievement – the cultivation of seed-giving grasses.’⁵¹⁵ Progress was never guaranteed for Islamic and Chinese science and technology which had been far ahead of that of Christendom and Europe went into decline because of the ‘debilitating confluence of world views and religious imperatives that worked together to minimise further expansion.’⁵¹⁶

Progress is not guaranteed but in the Neolithic period there was a flowering of creativity and technology yielding an expansion in the population which put pressure on the

⁵¹¹ Betsy Sparrow, Jenny Liu, and Wegner. Daniel M, 'Google Effects on Memory: Cognitive Consequences of Having Information at Our Fingertips,' *Science* 333 (2011): 776-78.

⁵¹² J. Bronowski, *The Ascent of Man* (London: Book Club Associates, 1973), 56.

⁵¹³ Arnold Toynbee, *Mankind and Mother Earth* (London: Book Club Associates, 1976), 38.

⁵¹⁴ Van Huyssteen, *Alone in the World?*, 54.

⁵¹⁵ Bernal, *Science in History*, 59.

⁵¹⁶ Hallion, *Taking Flight*, 35.

environment and led to the development of cities. In settling down and living in houses humans ‘domesticated themselves as they domesticated plants or animals’⁵¹⁷ for in order to live together in this new way aggression, which was a necessary part of hunting, would need to be controlled. The start of this process is surprising because ‘Neolithic communities based on domesticated plants and animals arose independently several times in different parts of the world after 10,000 BCE’⁵¹⁸ with different animals and crops being domesticated in different places. One suggested reason for this is that as hunter-gatherer humans had spread over the whole globe there came a point when that life style reached the limit of the population it could support and only then ‘were plant and animal husbandry taken up as a new way of life.’⁵¹⁹ So pressure on the environment resulted in this innovative change into a more settled community life and the success of this innovation places more pressure which is resolved by the building of cities as will be shown.

In this settled way of life with its seasonal work and storable food supplies of milk products as well as grain, there was time and energy for other creative activities. Weaving, which perhaps started with Paleolithic basketry, developed as textile manufacture with its interconnected technologies of sheep shearing, spinning, dyeing, loom construction, flourished as did pottery production. Metal, wood and stone working formed part of the ‘hundreds if not thousands of techniques and technologies large and small’ that ‘melded to produce the new mode of life.’⁵²⁰ Time became available to the human imagination so new possibilities in many areas were explored and tried out either in the face of some necessity or for amusement. The way in which human beings have learned to make use of the material universe depends upon our ability to produce enough food by means ‘which do not of themselves entirely exhaust the energy and time of that population.’⁵²¹

The establishment of these larger settled communities is connected with the rise of leadership and organisation as the population in any one centre expanded. Such a community would find the necessity of protecting large stores of food from raiders,

⁵¹⁷ McClellan III and Dorn, *Science and Technology in World History*, 18.

⁵¹⁸ *Ibid.*, 17.

⁵¹⁹ *Ibid.*, 16.

⁵²⁰ *Ibid.*, 21.

⁵²¹ Derry and Williams, *A Short History of Technology*, 45.

perhaps those who were not convinced of settling into villages. So it was that the ‘rich Neolithic town of Jericho’ ‘by 7350 BCE already had become a well-watered, brick-walled city of 2000 or more people.’⁵²² Such construction, perhaps seen as a necessity, would have required not only the ability to manufacture and lay the bricks but also a certain level of organisation and command and perhaps forced labour. But not all the Neolithic building projects were completed in the face of such a need.

We may never know the precise motives for the building of megalithic structures but in the case of Stonehenge a developing building project was sustained over a period of 1600 years. This monument embodies information from ‘observations of the sun and the moon over a period of decades’⁵²³ and marks their extreme and mean positions on the horizon. The work involved in building it, perhaps as many as 30 million man-hours, with the transporting of stones from as far away as modern day Milford Haven indicates a culture rich in time and food supplies at the very least. Who kept the vision and who called people to work we do not know. We may guess a practical purpose of helping the culture to know its position in the seemingly endless cycles of the heavenly bodies and to know the time to sow seed or prepare for winter. This may have been linked in with some form of religion or cultic practice. But this was a colossal feat of technology in its day and shows a people who were prepared ‘to dedicate effort and riches in creating monuments that called to the vaulted sky and its repeated patterns.’⁵²⁴ The engraved fragments of bone and tusk had become large stone monuments, and leaders and organisers of enlarging communities had emerged and they were needed in the emerging ever more technological world.

6.3 Cities and City States

Independently in different parts of the world the success of the Neolithic communities with their food supplies sustaining a growing population led to a challenge similar to that faced by the Paleolithic people when they reached the limit at which the ecosystem could support their lifestyle. As the Neolithic communities grew and coalesced so the demand for intensified agriculture grew and this forced social change and the developing of

⁵²² McClellan III and Dorn, *Science and Technology in World History*, 22.

⁵²³ *Ibid.*, 27.

⁵²⁴ Frank, *About Time*, 23.

hydrology to both tame river floods and irrigate the farm land. As McClellan and Dorn⁵²⁵ have shown in China, India, Mesopotamia, Egypt, Central America, and the Pacific coastal area of South America authoritarian states emerged which engaged in large scale works to control river water and make it available for irrigation. To do the work of building, maintaining, and repairing dams, dykes, and canals forced labour was used, so creating an underclass of labourers sometimes drawn from conquered peoples. The ability to control the water supply for agriculture was linked to a greater stratification of society with the development of tax collectors, armies, police, priests, and associated bureaucracies in which 'cadres of learned scribes developed mathematics, medicine, and astronomy.'⁵²⁶

Water was not just needed for agriculture but also as drinking water for the population as well for dealing with sewage. The Assyrian King Sennacherib, having constructed a dam on the Khosr River, built the first long distance aqueduct to carry the waters 'through a gently sloping masonry channel to Nineveh, some thirty-five miles to the southeast.'⁵²⁷ This served as an example to the Greeks who built their first aqueduct on the Island of Samos. This invention was also developed by the Romans 'who spread city life so widely and based its amenities so largely upon a lavish supply of water,'⁵²⁸ by constructing aqueducts throughout their empire. Some 300 years after the building a large sewer the first aqueduct to supply Rome with drinking water was built in 312 BCE and after that time 'no one in Rome drank from or bathed in the Tiber, which received the water from the sewers.'⁵²⁹

This brief look at the development of early technology and its impact on human culture has shown how the imaginative instinct which results in what we call technology has been with human beings since the dawn of consciousness. Building on all the development that went before, we then find a key technology in hydrology as being pivotal to the building of cities. This water technology continues to be of vital importance to this day even though the technology may not be the most up-to-date.

⁵²⁵ McClellan III and Dorn, *Science and Technology in World History*, 32-41.

⁵²⁶ *Ibid.*, 32.

⁵²⁷ R. J. Forbes, 'Mesopotamian and Egyptian Technology,' in Melvin Kranzberg and Carroll W. Pursell (eds.), *Technology in Western Civilization*. (New York: Oxford University Press, 1967), 31.

⁵²⁸ Derry and Williams, *A Short History of Technology*, 170.

⁵²⁹ A. G. Drachmann, 'The Classical Civilizations,' in Melvin Kranzberg and Carroll W. Pursell (eds.), *Technology in Western Civilization*. (New York: Oxford University Press, 1967), 62.

London still relies on Bazalgette's 19th century sewers carefully designed and constructed to provide 'the maximum rate of flow when there is little liquid moving through.'⁵³⁰ Of course there have been other major technological advances over the millennia and the modern city relies upon road and rail engineering, wired and wireless communication systems, electricity grids. The vulnerability of cities to the failure of any of these technologies if not direct attack by nuclear and other weapons might make people more circumspect about them, but cities continue to grow in size and number. Given our attempts to apply scientific thought to every aspect of modern life it is natural that attempts should be made to uncover scientific laws of the city.

6.4 Seeking a scientific theory of cities

'Cities are the crucible of civilisation There is an urgent need for a scientific theory of cities.' So begins Geoffrey West's TED lecture entitled 'The Surprising Math of Cities and Corporations'.⁵³¹ The urgent need is because of the rate of city construction and expansion across the globe, and West cites figures to show that by the second half of the twenty-first century our planet will be dominated by cities, and the urgency is because cities are the source of the problems of pollution, disease, global warming etc. He is also convinced that cities are the solution to the problems because, he says, 'cities are the vacuum cleaners, the magnets that have sucked up creative people.' He flatters his audience at this point by referring to them as 'super-creatives' i.e. the people who are going to solve the problems.

West's scientific theory is not a theory like Newton's first law of motion, Einstein's theory of relativity, or the second law of thermodynamics. What West and his team of researchers have done is to gather data from cities and attempted to correlate it to uncover an underlying structure. The data gathered is information on population size, disease rates, number of petrol stations, average walking speeds, wages, number of patents filed, etc. and the data is gathered for cities all around the world. The reason for doing things this way is that cities are very complex entities and to understand them in depth one would have to master so many different disciplines such as human physiology, traffic control, water supplies, waste removal, civil engineering, architecture. The list is

⁵³⁰ Derry and Williams, *A Short History of Technology*, 427.

⁵³¹ Geoffrey West, *The Surprising Math of Cities and Corporations* (TED, 2011 [cited November 29th 2012]); available from http://www.ted.com/talks/geoffrey_west_the_surprising_math_of_cities_and_corporations.html.

huge and very likely beyond a simple scientific theory. By simply collecting the data you ignore all this complexity and look for simplicity at a higher level.

This method of science is not new for ‘an increasing amount of cutting-edge scientific research is data-rather than theory-driven’⁵³² and contrasts with Popper’s view of science as being theories that are falsifiable⁵³³ and Kuhn’s view that scientific theories are to be hung onto and their explanatory power revealed rather than seen as refutable.⁵³⁴ Actually Kuhn might well regard what West is doing as the ‘fact-gathering’ from ‘the wealth of data that lie readily to hand’⁵³⁵ that precedes the development of theories and paradigms

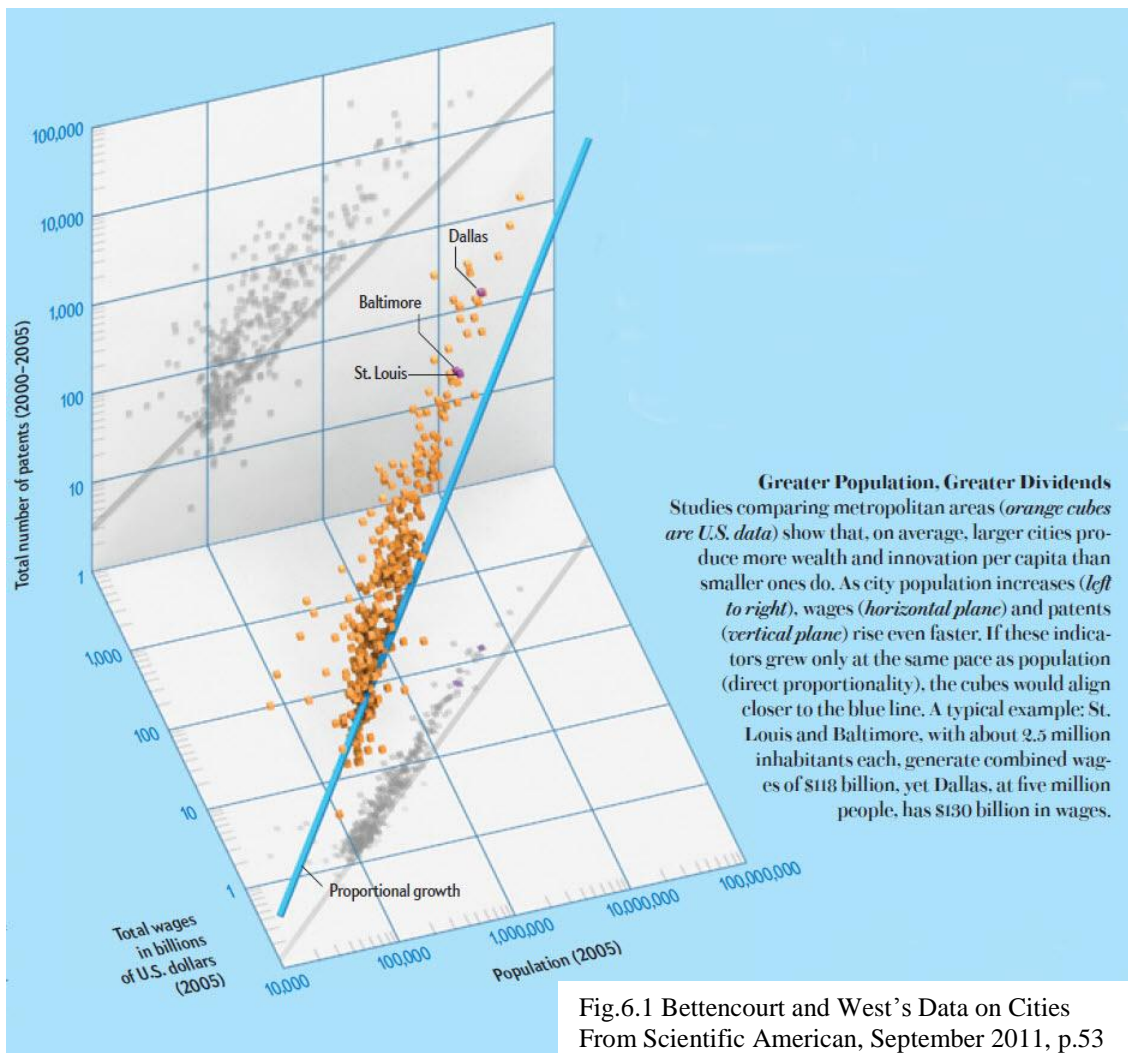

Fig.6.1 Bettencourt and West’s Data on Cities
 From Scientific American, September 2011, p.53

⁵³² John Naughton, 'Thomas Kuhn: The Man Who Changed the Way the World Looked at Science,' *The Observer*, August 19th 2012.

⁵³³ Karl R. Popper, 'Science: Conjectures and Refutations,' *Conjectures and Refutations* 5th ed. (London: Routledge and Kegan Paul, 1974), 37.

⁵³⁴ Kuhn, *The Structure of Scientific Revolutions*, 24.

⁵³⁵ *Ibid.*, 15.

in a new field. Having collected the data, West and his colleagues then construct graphs which correlate everything else to population size. What they claim to have discovered is that for all cities, wherever they are on the planet, the graphs demonstrate scaling, that is to say if you increase the size of the population for a given city then the other phenomena will increase in proportion. However there are two different rules of proportion that are demonstrated by the data. There is sub-linear scaling and super-linear scaling. An example of the former is the number of petrol stations. If the population of a city is doubled, increased by 100%, then the number of petrol stations increases by 85%, i.e. the number of petrol stations per capita of population decreases. This is true, West says, of any measure of infrastructure such as length of roads. So 'a city of eight million typically needs 15% less of the same infrastructure than do two cities of four million each.'⁵³⁶

Super-linear scaling is exhibited by phenomena such as wages and number of patents produced. In this case if you double the size of the population you more than double the size of that phenomenon. The increase is approximately 115% rather than 100%. This means that the value per capita increases. This combination of some things scaling sub-linearly whilst others scale super-linearly leads to the statement that 'compared with suburban or rural areas, cities do more with less.'⁵³⁷ This is what underlies West's belief that even though cities are the cause of many of the problems that we face today they are also the solution, or rather the 'super-creatives', the number of whom also scales super-linearly, will create the solutions. This looks very good but there is a down side in that there are undesirable phenomena which also scale super-linearly. West mentions, in the TED lecture referred to above, crime, cases of Aids and flu as being amongst these. In spite of these problems people still flock to the cities because of the perceived and real benefits.

It is important that we understand the nature of the evidence being presented here and we have to be careful in understanding these curves and equations. This is statistical information and it is possible, even likely perhaps, that no one city lies exactly on the curves for even one, let alone all, the datasets examined. The diagram in the Scientific

⁵³⁶ Luis M. A. Bettencourt and Geoffrey West, 'Bigger Cities Do More with Less,' *Scientific American*, September 2011, 52.

⁵³⁷ Ibid.

American article⁵³⁸, see Fig.6.1 above, which is meant to prove West's point also demonstrates the scatter and this is acknowledged by the authors when they admit that 'actual cities deviate to varying degrees from the roughly 15% enhancements that come with size.'⁵³⁹ This evidence is not exact and as such the theory is not open to easy refutation. Earlier work by West was in Biology where a sub-linear scaling was discovered to be at work. West refers to it in the lecture: 'You tell me the size of a mammal, I can tell you at the 90% level everything about it in terms of its physiology, life history, etc.' However not every biologist was persuaded by his analysis and his declaration that every fundamental law has exceptions.⁵⁴⁰

Many would argue that a fundamental law cannot have exceptions and is therefore, in principle, refutable. But West is referring to an underlying statistical law which because it appears to be repeatable all over the world in all types of cities feels that it is fundamental. Of course, what would be really useful to know is if there are cities that do even more with even less, i.e. are more efficient than the average, so that an investigation can be made into the relevant factors that cause this. Such research may well involve all those many different disciplines such as human physiology, traffic control, water supplies, waste removal, civil engineering, architecture etc. that the initial research has ignored.

West's team of researchers have come up with 'hockey stick' graphs which in theory allow you to go on for ever expanding the size of cities into the future. But West states that this cannot happen because of 'Malthusian effects' which will cause cities to stop growing and even go into decline. Whilst he does not elaborate on what he means by this he envisages that increasing numbers of innovations will be necessary so the city will effectively be re-invented and that these innovations will have to come at an increasing rate in the future to prevent the meltdown of cities. Work on innovations is already going on with a view to driving down the use of resources. Driven by the question, 'How can we have all the good things without all the bad ones?' Kent Larson⁵⁴¹ has proposed

⁵³⁸ Ibid., 53.

⁵³⁹ Ibid., 52.

⁵⁴⁰ Johan Lehrer, 'A Physicist Solves the City,' *The New York Times*, December 17th 2010.

⁵⁴¹ Kent Larson, *Brilliant Designs to Fit More People in Every City* (TED, 2012 [cited January 28th 2013]); available from http://www.ted.com/talks/kent_larson_brilliant_designs_to_fit_more_people_in_every_city.html.

flexible living space with ‘robotic’ walls and shared use vehicles, such as bicycles and mini electric folding cars, linked to mass transit systems. Alex Steffen⁵⁴² believes that increasing population density, as opposed to the car driven urban sprawl of many modern American cities, will help solve problems such as exhaust emissions and reduce the per capita energy use by 90% in some cases.

Not everybody agrees with West’s approach and Ludger Hovestadt⁵⁴³ criticises him for failing to engage with architects and for using ‘aristocratic’ and ‘imperialistic’ types of mathematics, but he also thinks the future lies in imaginative innovation. The difference is that he believes the starting point lies in finding a form of mathematics that allows us to build the cities we want to build. Undoubtedly urbanisation is happening⁵⁴⁴ now but there is a reverse movement exemplified by my youngest daughter and one of her cousins in Canada who, in their thirties, wearied of their cities, London and Toronto respectively and moved to more spacious places which are smaller residential communities.

The human race is demonstrating a desire to live in communities and cities are mainly ‘where people want to be.’⁵⁴⁵ The infrastructure for living, working, and playing in these communities has developed as technology has expanded the possibilities of what we can achieve with the resources we find around us. We are becoming aware of the problems and as the talks cited above show the assumption is that we will solve the problems with more and more technological innovation. We do not know if there are limits or indeed what the future holds with regard to human behaviour especially with regard to living in places of increasing population density, but somehow cities appear to us to be the future. Remarkably this view ties in with a biblical Christian viewpoint as we shall now see.

6.5 Cities and God

6.5.1 Revelation’s Surprise

At the end of Revelation, the last book of the Christian Bible, after God’s final victory over the forces of evil has taken place and God has judged humankind we are given a vision of God’s redeemed and renewed creation. Bearing in mind all the destruction

⁵⁴² Alex Steffen, *The Shareable Future of Cities* (TED, 2011 [cited January 28th 2013]); available from http://www.ted.com/talks/alex_steffen.html.

⁵⁴³ Ludger Hovestadt, *The Surprising Success of Fundamental Proportionism* (Vimeo, LLC, 2012 [cited January 28th 2013]); available from <http://vimeo.com/44548590>.

⁵⁴⁴ Larson, *Brilliant Designs to Fit More People in Every City*.

⁵⁴⁵ Ibid.

predicted for cities throughout the book and that the author will have been familiar with the Genesis story of the Garden of Eden and the 'Fall' of humankind, we might have expected that the renewed creation would be a Paradise, that is to say, a garden or, more strictly, a walled garden⁵⁴⁶ especially as the LXX translation of Genesis 2.8 uses that word, paradise, for the garden 'the Lord God had planted' 'in the east, in Eden.' Isaiah had seen God's reign of righteousness linked to the demise of the city which would become 'deserted' and 'levelled completely' (Isa. 32.14 & 19). The author may also have been aware of Jesus' words in response to the penitent thief's request, 'Jesus, remember me when you come into your kingdom.' He replies, 'I tell you the truth, today you will be with me in paradise.' (Lk. 23.42f) But what John sees 'coming down out of heaven from God' is 'the Holy City, the new Jerusalem.' (Rev. 21.2)

This city is not simply a paradise regained as if the clock were being wound back to Eden and a new, but slightly different, start is being made. This city 'fulfils humanity's desire to build out of nature a human place of human culture and community'⁵⁴⁷ even though it comes down from heaven, given by God. The statements that 'the kings of the earth will bring their glory into it' and 'people will bring into it the glory and the honour of the nations' (Rev. 21.24 & 26) assume that the people of this world have some things that are glorious and honourable and worth laying before God in acknowledging God's glory. This offering is not to belittle what is offered but to acknowledge its ultimate 'source in God to whom all glory and honour belong.'⁵⁴⁸ God is perceived as acknowledging and honouring human aspiration and creativity and also transforming them with the very presence of God in the midst of human community and the elimination of all that is evil.

Before this point in Revelation John has not mentioned Jerusalem by name but that city is referred to in the earlier passage about the two witnesses who are killed by 'the beast that comes up from the abyss' when John records 'their bodies will lie in the streets of the great city, which is figuratively called Sodom and Egypt, where also their Lord was crucified.' (Rev. 11.7f) Elsewhere we are told: 'The great city split into three parts, and the cities of the nations collapsed. God remembered Babylon the Great and gave her the

⁵⁴⁶ F.C. Fensham, 'Paradise,' in J.D. Douglas (ed.), *The Illustrated Bible Dictionary (Part 3)*. (Leicester: Inter-varsity Press, 1980), 1155.

⁵⁴⁷ Richard Bauckham, *The Theology of the Book of Revelation*, Kindle ed. (Cambridge: Cambridge University Press, 1993), loc 1687.

⁵⁴⁸ *Ibid.*, loc 1696.

cup filled with the wine of the fury of his wrath.’ (Rev. 16.19) Babylon is to receive ‘the most wholehearted opposition conceivable from an all-powerful and all-holy God’⁵⁴⁹ because Babylon is: ‘BABYLON THE GREAT, THE MOTHER OF PROSTITUTES AND OF THE ABOMINATIONS OF THE EARTH.’ (Rev. 17.5) Jerusalem is being linked, not only with Sodom and Egypt ‘whose names are proverbial for wickedness and oppression’,⁵⁵⁰ but also Babylon ‘the world system which is in rebellion against God.’⁵⁵¹ Whilst it is possible to understand that Rome is being referred to ‘under the name of Babylon’⁵⁵² it seems better, because of the tangential reference to Jerusalem which connects it with the ‘great city’ which is linked to Babylon the Great, to understand Babylon as ‘the great city, the symbol of man in community opposed to the things of God’ and that ‘John is looking forward to the overthrow of all the evil that Babylon stands for.’⁵⁵³ But after that overthrow and the cities of the world have collapsed it is not a rural idyll that John sees as God’s new creation, the focus is a renewed city of Jerusalem, a renewed version of that city which had earlier been lumped in with the rest of the cities and earmarked for destruction.

Having been faced with the surprise that it is a city that is the focus of God’s new heaven and new earth in Revelation, giving that in the rest of the book it is cities that are the focus of opposition to God’s rule, we need to look at the origin of cities as depicted in the Old Testament and how God comes to be involved with them, both favourably and in opposition to them.

6.5.2 The Biblical beginnings of Cities

The first city is recorded in Genesis as being built by Cain and named after his son Enoch. The circumstances were that Cain had murdered Abel and been confronted by God who declares that Cain ‘will be a restless wanderer on the earth.’ (Gen. 4.12) God also ‘put a mark on Cain so that no-one who found him would kill him’ (Gen. 4.15) in response to Cain’s fear of being murdered himself. Cain moves away, becomes the father

⁵⁴⁹ Leon Morris, *Revelation: An Introduction and Commentary*, ed. R.V.G. Tasker, *Tyndale New Testament Commentaries* (London: Tyndale Press, 1969), 201.

⁵⁵⁰ *Ibid.*, 150.

⁵⁵¹ Michael Wilcock, *I Saw Heaven Opened: The Message of Revelation*, ed. John R.W. Stott, *The Bible Speaks Today* (London: Inter-Varsity Press, 1975), 134.

⁵⁵² N. Turner, ‘Revelation,’ in Matthew Black and H. H. Rowley (eds.), *Peake's Commentary on the Bible*. (London: Thomas Nelson and Sons, 1962), 1053.

⁵⁵³ Morris, *Revelation: An Introduction and Commentary*, 180.

of Enoch whilst building a city which he named ‘after his son Enoch’. (Gen. 4.17) Westermann proposes an amendment to the text so that it is Enoch who built the city and named it after himself.⁵⁵⁴ His argument which comments, citing K. Budde, that in a genealogy after the birth of a son nothing further about the father is said⁵⁵⁵ appears to be confounded in that a few verses later (Gen. 4.23f) we have more information about Lamech after the announcement of his sons. The further argument that because Cain was a farmer ‘it is scarcely possible to say that he was at the same time the builder of a city’⁵⁵⁶ fails to reckon with the fact that the Hebrew word translated as ‘city’ ‘can be applied to any human settlement, small or great’⁵⁵⁷ and that, as discussed above, Neolithic farmers built and developed settlements.⁵⁵⁸ The biblical text, however, is not attempting to tell the same story as modern archaeological research.

The story that the editor who put Genesis together is telling us is that the first city comes after Cain has gone ‘out from the Lord’s presence’ (Gen. 4.16) and, as it is an act of providing for his own settlement and security, Cain is defying God’s verdict that he will be a restless, but safe, wanderer. In other words, this first city ‘is the direct consequence of Cain’s murderous act and of his refusal to accept God’s protection.’⁵⁵⁹ In the text there is no criticism of Cain, but then there is no criticism of Lamech when he boasts to his wives, ‘I have killed a man for wounding me, a young man for injuring me.’ (Gen. 4.23)

The pattern is repeated with the building of the tower of Babel. After the flood ‘God blessed Noah and his sons, saying to them, ‘Be fruitful and increase in number and fill the earth.’ (Gen. 9.1) After the giving of the rainbow as the sign of God’s promise not to destroy all life by a flood (Gen. 9.8-17) but before the account of an incident that leads to the cursing of Canaan, we are told, ‘The sons of Noah who came out of the ark were Shem, Ham and Japheth . . . and from them came all the people who were scattered over the earth.’ (Gen. 9.18f) At the end of the lists of the ‘clans of Noah’s sons’ we are told, ‘from these the nations spread out over the earth after the flood.’ (Gen. 10.32) So God commanded a spreading out over the earth and it happened as a scattering and the story

⁵⁵⁴ Westermann, *Genesis 1-11: A Continental Commentary*, 322.

⁵⁵⁵ *Ibid.*, 327.

⁵⁵⁶ *Ibid.*

⁵⁵⁷ Derek Kidner, *Genesis: An Introduction and Commentary*, ed. D. J. Wiseman, *The Tyndale Old Testament Commentaries* (London: Tyndale Press, 1967), 77.

⁵⁵⁸ McClellan III and Dorn, *Science and Technology in World History*, 18ff.

⁵⁵⁹ Jacques Ellul, *The Meaning of the City* (Grand Rapids: William B. Eerdmans, 1973), 5.

of Babel is telling us something about how it happened. Initially everyone spoke a single language and settled in the plain of Shinar where, for fear of being scattered over the face of the earth, they determined to make bricks to build a city and a tower that would reach to the heavens. When God saw what was happening:

‘The Lord said, ‘If as one people speaking the same language they have begun to do this, then nothing they plan will be impossible for them. Come let us go down and confuse their language so that they will not understand each other.’

So the Lord scattered them from there over all the earth, and they stopped building the city. That is why it is called Babel – because there the Lord confused the language of the whole world. From there the Lord scattered them over the face of the whole earth.’ (Gen. 11.6-9)

This story, in its pre-Genesis origins may have drawn on stories with varying aetiologies such as the reason for the diversity of languages⁵⁶⁰, the existence of the ziggurats⁵⁶¹, and the naming of Babylon, ‘even though the etymology claimed in verse 9 is false.’⁵⁶²

However the predominant motif in the text as we have it is that of scattering with the confusion of languages as the explanation of how that scattering was brought about.

Having been instructed to spread over all the earth the people express their desire for unity along with their fear of being scattered by deciding to build a landmark city with a high tower where they can ‘settle down so as to no longer be wanderers on the earth’.⁵⁶³

God understands their single language as a means by which they will continually express their independence of God who then confuses their language and scatters them in fulfilment of the command that was originally given.

Both Enoch and Babel are cities built in rebellion against God. The understanding of the cities built by Nimrod, the ‘mighty hunter before the Lord’ (Gen. 10.9), is rather more subtle. Nimrod was a son of Cush, a son of Ham, and is described as a ‘mighty warrior’ (Gen. 10.8), a phrase which Westermann translates as ‘the first man of might’⁵⁶⁴, and an empire builder who established various cities, including Babylon, in Shinar and then others, including Nineveh, in Assyria (Gen. 10.10ff). The suggestion that ‘instead of

⁵⁶⁰ Westermann, *Genesis 1-11: A Continental Commentary*, 535.

⁵⁶¹ S. H. Hooke, ‘Genesis,’ in Matthew Black and H. H. Rowley (eds.), *Peake's Commentary on the Bible*. (London: Thomas Nelson and Sons, 1962), 185.

⁵⁶² Brueggemann, *Genesis*, 97.

⁵⁶³ Ellul, *The Meaning of the City*, 17.

⁵⁶⁴ Westermann, *Genesis 1-11: A Continental Commentary*, 496.

‘hunter,’ we translate ‘plunderer’ or ‘conqueror’⁵⁶⁵ is not out of keeping with the picture of Nimrod we are given, but the focus is on building a kingdom. As the scattering takes place local unity and protection is created in the form of Nimrod’s empire. Human beings are again expressing their independence of God and self-reliance even as they find themselves in the place ‘over the face of the whole earth’ (Gen. 11.9) that God intends them to be.

The key point here is that cities are intended and built by human beings. In origin in the biblical record there is a strong sense of rebellion against God, a determination by human beings to be masters of their own destiny. The idea of the city is human in origin and all the political and relational structures that flow from cities are human in origin and not dictated by God. In no way did God draw up any form of blueprint of the city or other human institutions for human beings to follow. Rather, this all takes place ‘in the arena of freedom and not in the changeless world of necessity.’⁵⁶⁶

Initially the cities belong to human beings, not to God. It is possible to argue that ‘the whole world belongs to God – including the city. It was made by God’s hand, for God placed in humanity the capacity to create the city.’⁵⁶⁷ But to do so means other things such as weapons of mass destruction have to be attributed directly to God as well. Certainly God is ultimately responsible for everything that human beings, made by God in the ‘image of God’, have done. Indeed the Gospel of Jesus Christ which culminates in God’s creation of ‘a new heaven and a new earth’ (Rev. 21.1) is about God taking responsibility for and dealing with human activity but the importance of human freedom, imagination, and creativity must not be obscured. God does not accept everything we do, hence the abiding biblical theme of judgement

After the story of Babel, the genealogy of Shem focuses on the line leading down to Abram and his family circumstances at the time of God’s call to him, accompanied by a promise of blessing, to leave behind his urban life in the Chaldean city of Ur, and later Haran, and become a nomad in the land of Canaan. (Gen. 12-13) This apparent rejection of urban life by God is reinforced by other events in the life of Abram; Sodom and Gomorrah are destroyed on his watch and he gets into difficulties when in contact with

⁵⁶⁵ Ellul, *The Meaning of the City*, 12.

⁵⁶⁶ Brueggemann, *Genesis*, 93.

⁵⁶⁷ Robert C. Linthicum, *City of God, City of Satan*, 1st ed. (Grand Rapids: Zondervan, 1991), 39.

urban dwelling kings Pharaoh (Gen. 12.10-20) and Abimelech (Gen. 20.1-18). However matters are not quite so straight forward. Abraham's excuse for lying to Abimelech saying that Sarah was his sister was that he thought, 'there is no fear of God at all in this place, and they will kill me because of my wife.' (Gen. 20.11) But he was wrong for Abimelech did respond to God appropriately when he was made aware of what had happened and so avoided punishment from God who had acknowledged the integrity of Abimelech's heart and warned him so that he would not sin (Gen. 20.6). The situation with Sodom and Gomorrah is even more intriguing.

God visits Abraham and tells him he will have a son in his old age (Gen. 18.10), but before leaving he resolves to tell him that he is about to check out Sodom and Gomorrah because 'how great is the outcry' (Gen. 18.20) against them. Abraham then enters into a kind of Dutch auction with God and gets agreement that the cities will not be destroyed if ten righteous people can be found in them. (Gen.18.32) It has taken a great outcry to bring God to the point of contemplating destroying the cities, but they are not without hope even then. Abraham remonstrates with God, 'will you indeed sweep away the righteous with the wicked Shall not the Judge of all the earth do what is just?' (Gen. 18.23ff) The cities are not to be doomed because they are cities but because of the activities of their inhabitants. This passage is remarkable in that 'it is as though Abraham is Yahweh's theological teacher and raises a question that is quite new for him'⁵⁶⁸, an interpretation that is strengthened by the fact that in verse 22 'a very early text note (not to be doubted in its authority and authenticity)'⁵⁶⁹ shows that 'the succession of the subjects was originally reversed.'⁵⁷⁰ This means it should read 'the Lord remained standing before Abraham' rather than 'Abraham remained standing before the Lord.' The strong suggestion here that God has to learn what righteousness and justice mean in the world of human beings is one that will be revisited in a subsequent chapter of this thesis.

There is clearly an ambivalence here concerning cities. The activities of human beings within them may merit God's judgement to the extent that the cities are destroyed but they are not closed to God who speaks to both Abram and Abimelech whilst they are resident in cities. Even if the crimes of Sodom and Gomorrah are very great the

⁵⁶⁸ Brueggemann, *Genesis*, 168.

⁵⁶⁹ Ibid.

⁵⁷⁰ Claus Westermann, *Genesis 12-36: A Continental Commentary*, trans. John J. Scullion (Minneapolis: Fortress, 1995), 285.

possibility of some of the residents being righteous is not discounted and could be a reason for judgement being averted. However Abraham, his son Isaac, his grandson Jacob, and his great-grandsons, the heads of the tribes of Israel, remained nomadic herdsmen. But when his descendants came out of Egypt with Moses at their head they were ready for the more urbanised life that lay ahead of them. There was no question of them destroying the towns and cities of the Promised Land even though they did destroy the Canaanite towns of Arad in the Negeb after the king there had an initial military success against them (Nu. 21.1ff) and also the towns and encampments of the Midianites after the incident of the worshipping of Baal at Peor. (Nu. 25 & 31.1-12) But these places were outside of the Promised Land.

6.5.3 Urbanisation and Judgement

When it comes to the Promised Land the instructions to the people of Israel are to drive out the people already there and take possession of it including the ‘fine, large cities’ (Dt. 6.10) that they did not build as well other artefacts which relate to a settled life. In other words the instructions allow for the fact that human beings desire to live in settled communities. God is not assuming that the cities are intrinsically evil, indeed cities are specifically allocated so that the Levites, who are effectively the civil service as well as those responsible for the regular worship of the Lord in the tabernacle, can live in them and ‘cities of refuge’ are designated so that people who commit manslaughter will have a place of safety from vengeful relatives of victims. (Nu. 35) With regard to these latter cities Ellul remarks that ‘the city is called at least once to play a positive role in the order of preservation which is part of God’s plan for the world.’⁵⁷¹ However there are temptations associated with this settled and relatively easy life in the fertile land they are to occupy. The first is that they will ‘forget the Lord, who brought’ them ‘out of the land of Egypt’ and the second is that they will worship the ‘gods of the people who are all around’ them. (Dt. 6.11-14) If the people do give in to these temptations then they will find that their cities will offer them no protection against God’s hostility towards them and will be laid waste. (Lev. 26.23-33) The question here is not the style of life of the people, be it in cities or villages or even nomadic, it is the faithfulness of the people to God.

⁵⁷¹ Ellul, *The Meaning of the City*, 90.

Whilst the people of Israel took over the villages and cities of Canaan the Ark of God's Covenant and the associated tabernacle remained essentially nomadic. 'I have not lived in a house since the day I brought up the people of Israel from Egypt to this day did I ever speak a word saying, "Why have you not built me a house of cedar?"' (2Sa. 7.6f) is God's response to King David's suggestion of building a temple for God. David had captured Jerusalem from the Jebusites, who had been a thorn in the side of the Israelites since their invasion of the land, made it his capital city, built his palace, and brought the Ark of the Covenant into it. The significance of building a temple in the city is to claim that the city is special, a focus of worship offered to God, and in some way it becomes God's city. God does not reject Jerusalem. God says that David is not to be the builder of the temple but his 'offspring' will be (2Sa. 7.12f), and in saying to David that 'the Lord will make you a house' (2Sa. 7.11) God is not only saying that David himself is accepted and special but also that God is accepting David's offer of a city. God is 'accepting from David's hands the consecration of man's counter-creation.'⁵⁷² In the biblical story this is the beginning of God's special relationship with Jerusalem which ends with the 'new Jerusalem' of the book of Revelation.

Jerusalem's relationship with God was a very rocky one which Ezekiel in chapter 16 of his prophecy recounts as an allegorical tale in which God gives life to her as a Canaanite city and later takes her as a wife, lavishing great gifts upon her. God's love is repaid by the city prostituting herself with other nations, even including 'Babylonia, a land of merchants' (v.29), to the extent of sacrificing her own children 'as food to the idols'. (v.20) Judgement from God is forthcoming, 'I will surely bring down on your head what you have done' (v.43), but will be followed by mercy and restoration along with Sodom and Samaria who had not sinned to the extent that Jerusalem had. The allegory ends with Jerusalem sitting silently chastened and ashamed of her past conduct. (v.63)

Jeremiah also speaks of judgement on Jerusalem as God bringing about 'a disaster on this place that will make the ears of everyone who hears of it tingle.' (Jer. 19.3) To this prophet is also attributed the Lamentation over fallen Jerusalem which begins, 'How deserted lies the city, once so full of people!' (Lam. 1.1) and ends with the prayer, 'Restore us to yourself, O Lord, unless you have utterly rejected us and are angry

⁵⁷² Ibid., 101.

with us beyond measure.’ (Lam. 5.21f) This call upon God’s mercy can be seen as answered in the prophet Hosea attributing to God, ‘How can I give you up, Ephraim? How can I hand you over, Israel? My heart is changed within me; all my compassion is aroused. I will not carry out my fierce anger.’ (Hos. 11.8f) Isaiah speaks of the outcome of God’s mercy in the face of the delivery of justified punishment, ‘Behold, I will create new heavens and a new earth. I will create Jerusalem to be a delight.’ (Isa. 65.17f)

The Old Testament prophets also announce judgement on other nations and cities. In the opening chapters of Amos, for example, a number of cities are cited as provoking God’s anger including; Damascus, Ashdod, Ashkelon, Tyre, Teman, Bozrah, Rabbah and Kerioth. The underlying cause is how they treated other peoples with violence and injustice. Damascus ‘threshed Gilead with sledges having iron teeth’ (Am. 1.3) and Tyre ‘sold whole communities of captives to Edom, disregarding a treaty of brotherhood.’ (Am. 1.9) Babylon is a frequent target with Jeremiah calling, ‘Take up your positions round Babylon, all you who draw the bow. Shoot at her! Spare no arrows, for she has sinned against the Lord’ (Jer. 50.14) and declaring, ‘Before your eyes I will repay Babylon and all who live in Babylonia for all the wrong they have done in Zion.’ (Jer. 51.24) Isaiah also join in declaring that ‘Babylon, the jewel of the kingdoms....will be overthrown by God like Sodom and Gomorrah’ (Isa. 13.19) and warning that ‘a catastrophe you cannot foresee will suddenly come upon you.’ (Isa. 47.11) Because of this coming disaster upon Babylon people in the city, presumably any of the people of Israel and Judah who are resident there, are called upon at that point to ‘flee from Babylon! Run for your lives! Do not be destroyed because of her sins. It is time for the Lord’s vengeance.’ (Jer. 51.6) This same call is heard again in Revelation, ‘Come out of her my people, so that you will not share in her sins, so that you will not receive any of her plagues.’ (Rev. 18.4)

When they the people of Judah were taken captive to Babylon the instructions had been different. Then they were to settle down and increase in number and to ‘seek the peace and prosperity of the city because if it prospers, you too will prosper.’ (Jer. 29.7) The point is that because the city is a work of human beings ‘God looks down even on it

with love⁵⁷³ and wants Babylon to prosper but not on its own independent and rebellious terms. Even though Babylon is prophesied to be heading towards fierce judgement it is subject to the love of God whose ultimate purpose is not destruction but new creation.

The prophets announced God's judgement upon Jerusalem as upon the whole people of Israel in their two separate nations. But there was always that awareness of God's steadfast love which meant that mercy could be sought and instead of there being total destruction, salvation and restoration could be hoped for. This is the prophetic basis of John's vision of a new heaven and a new earth with the New Jerusalem. God had adopted the city and so in spite of all its failures and sinfulness it would not be abandoned. This even applies to other cities as we see when Isaiah includes in the midst of a prophecy announcing judgement on Egypt, 'In that day five cities in Egypt will speak the language of Canaan and swear allegiance to the Lord Almighty' (Isa. 19.18) and 'The Lord Almighty will bless them, saying, "Blessed be Egypt my people, Assyria my handiwork, and Israel my inheritance."' (Isa. 19.25) The people of Nineveh repented when Jonah reluctantly proclaimed judgement on that city and seeing them turning from their evil ways God 'had compassion and did not bring upon them the destruction he had threatened.' (Jnh. 3.10) In this story there is a universalism to God's love rather than it being directed exclusively towards God's chosen people of Israel and so 'he pardons the city itself when these men discover that they belong to the Lord.'⁵⁷⁴ There is hope of prosperity for cities even though the prophetic vision is of their destruction and even Jesus lamented for Jerusalem (Mt. 23.37f) and wondered if 'when the Son of Man comes, will he find faith on the earth?' (Lk.18.8)

6.6 Conclusion

In this chapter we have seen how cities developed out of and are dependent upon human imagination, creativity and technology. Even though these cities are vulnerable and suffer from many problems they are seen as the future for the human race. What they offer in terms of security, employment, and lifestyle is such that human energy is focussing on improving and developing them to reduce the problems rather than find an alternative way of living. In the Biblical narrative cities appear as a statement of human independence from God. As such they result from and lead people into sin and evil and if

⁵⁷³ Ibid., 74.

⁵⁷⁴ Ibid., 70.

human beings determinedly cling to them rather than admit human dependence on God then ultimately the cities face God's judgement and destruction. In the book of Revelation the author is challenging his city dwelling readers to recognise the hubris of their cities. In this he offers not just the stick of judgement but also the carrot of 'an alternative and greater attraction'⁵⁷⁵ by way of the New Jerusalem, the best city to belong to. God does not hate cities as such. God loves them as the work of the hands of those creatures created in 'God's Image' to have dominion over God's creation. So, out of love, God adopts and transforms the city, the product of human aspiration and technology, to be the centrepiece in the renewed glory of God's new creation showing that 'the future is not the result of history, but depends on the sovereign act of God in bringing something new.'⁵⁷⁶ Human cities with their advancing technology hold out great hope for the future but this will come with even more problems to be solved. However the 'human hope for salvation' lies 'finally not in technology, politics, culture or nature, but in God's promise to make all things new,'⁵⁷⁷ recognising that the 'new' includes this product of human aspiration, creativity, and technology. The fact that the 'city' is not to be consigned to an eternal scrapheap demonstrates that human technology as a whole is not to be so consigned either. Rather what we perceive is that human technology has a place in God's eternal purposes.

There is in the Biblical narrative an ambiguity about cities and their relationship to God. This ambiguity is resolved in the new heaven and the new earth, the product of God's new creation, where the appearance of the New Jerusalem is accompanied by the declaration, 'the home of God is among mortals', from God's throne. (Rev. 21.3) The city, this complex development of intertwining technologies, is to be transformed. This product of human technology is accepted and transformed in line with God's purposes. This is indicated by the word 'new' which also prefixes 'heaven' and 'earth'. Human creativity and the technologies it has spawned are not just to help us survive and thrive in this present world. Rather, transformed by the loving action of the creator God, they are shown to have a place in God's eternal purposes.

⁵⁷⁵ Bauckham, *The Theology of the Book of Revelation*, loc 1621.

⁵⁷⁶ Wilkinson, *Christian Eschatology and the Physical Universe*, 66.

⁵⁷⁷ Richard Bauckham and Trevor Hart, *Hope against Hope* (London: Darton, Longman & Todd, 1999), 176.

Chapter 7

Divine and human creativity

At the beginning of this thesis I set out to bring together two different strands of my experience. The first was that of being an engineer within the major branch of engineering and technology that is the aircraft industry in which a high level of creativity has been evidenced over the years. The second is that of being a theologian, indeed an ordained priest in the Church of England. This desire to bring these strands together found dissatisfaction with the usual approach of theology and philosophy towards technology which, often in critical vein, viewed technology as ‘a thing, or at least a force, as if it had an existence of its own.’⁵⁷⁸ Whilst there are good empirical grounds for such an objectification the result can be a demonising of technology which gives little help in understanding how it may be dealt with. This in turn results in the development of a victim mentality on the part of people sensing themselves opposed to this unstoppable juggernaut of technology but finding ‘neither within nor without themselves a compensating force for the one they call into question.’⁵⁷⁹ A full appreciation of human technology must take into account human creativity which is evident in many different human activities, not least technology itself.

7.1 To be human is to be creative

In earlier chapters the examination of this phenomenon has demonstrated just how pervasive creativity is in human activities as long as a too narrow and elitist definition of ‘creativity’ is not insisted upon. If creative people are defined metaphorically as those who ‘discover a large new continent’ of knowledge to the exclusion of those who survey the ‘hidden valleys,’⁵⁸⁰ as Jaki insists, then not many people are creative. However as human beings come to comprehend, let alone change, the world around them they are engaged in imaginative and creative activity. Meaningful, as opposed to rote, learning ‘involves the personal construction of knowledge’ and in this way ‘creativity becomes

⁵⁷⁸ Florman, *The Existential Pleasures of Engineering*, 48.

⁵⁷⁹ Ellul, *The Technological Society*, 145.

⁵⁸⁰ Jaki, ‘Theological Aspects of Creative Science,’ 153.

the vehicle for understanding⁵⁸¹ as we create within our own minds a network of ideas, a pattern of understanding, so that we can survive, navigate our surroundings, including relationships with other people, and flourish through planning our activities. This process may well begin before birth. Human creativity is a function of human imagination which also underlies human knowledge.

It seems that human beings are 'intrinsically motivated to understand and construct meaning.'⁵⁸² They are 'pattern seeking creatures'⁵⁸³ whose brains analyse the information provided by the sensory organs using their inherent imaginative ability to build up an understanding of what the outside world is like. A form of mental picture, in the widest metaphorical sense and not simply visual as language is important in this process, is built up by the imagination and tested against memories of past experience and future events as they happen. This picture becomes not just an understanding of how things are but also how they are expected to be and what they might become if certain actions are taken. Incorporated in this is not just a view of static space and objects but also the relationships between objects in the outside world which in their subtlest forms include those between people. Indeed it may well be that the human relationships between a child and its parents are amongst the earliest aspects of this pattern seeking and building activity. In other words by seeking and finding patterns in the sensory information supplied to our brains our imaginations build an internal counterpart to the external world which can be considered independently of it. Memory is vital in this process of creating and transforming 'the internal analogues we construct of the real world.'⁵⁸⁴ Through this means expectations of future events can develop. If particular predictions do not prove correct then these unexpected experiences will have to be taken into account and the model creatively revised. How easily such revision happens will depend on the nature of the variation from expectation and how developed and complex the internal model has become. Even if predictions do come true the model will be confirmed only for the time

⁵⁸¹ Ronald A. Beghetto and Jonathan A. Plucker, 'The Relationship among Schooling, Learning, and Creativity: "All Roads Lead to Creativity" or "You Can't Get There from Here",' in James C. Kaufman and John Baer (eds.), *Creativity and Reason in Cognitive Development*. (New York: Cambridge University Press, 2006), 324.

⁵⁸² Runco, 'Reasoning and Personal Creativity,' 102.

⁵⁸³ Steve Jones, 'View from the Lab,' *Daily Telegraph*, 21st October 2008, 29.

⁵⁸⁴ Cohen, 'Overview: Conclusions and Speculations,' 388.

being because the mental model, like all human concepts is ‘*underdetermined* by the data’⁵⁸⁵ and therefore susceptible to future modification in the light of new experiences.

Both the knowledge and the mental activity that produces it are predominately subconscious. There is a congruence here between what psychologists term ‘associational knowledge’ which ‘is commonly held to be implicit or unconscious’⁵⁸⁶ and Polanyi’s description of ‘tacit knowledge’⁵⁸⁷ which undergirds all our interactions with reality without our being aware of it. The way human minds and brains carry out such activity is not well understood and is the subject of continuing research. In the field of vision, where most of the time we believe what we see, the occurrence of visual illusions⁵⁸⁸, for instance, poses the question of ‘how observers can respond so effectively to objects and conditions in the physical world when the sources of all retinal stimuli are inevitably ambiguous.’⁵⁸⁹ Guided by the thought that the evolution of the visual system will have happened in a manner which assists the observer to act in a useful way, Purves and Lotto reach the conclusion, which they acknowledge as counterintuitive, that ‘the visual system is not organised to generate a veridical representation of the physical world, but rather is a statistical reflection of visual history.’⁵⁹⁰

Such a conclusion is indeed ‘counterintuitive’ and leaves open questions about the amount of detail, unnecessary for survival, which we do apparently see. Their work is also restricted to vision whereas when a child is learning to ‘see’ its environment the faculty of sight develops alongside other senses, notably ‘touch’ in the exploration of surfaces, edges, and corners. In other words ‘touch’ will provide additional data so that the data from ‘sight’ can be creatively interpreted to yield a more accurate mental construct of the world. Whilst total accuracy is not needed, a more accurate mental model will be superior to a less accurate one when it comes to appropriate action. However there will be a limit because too much detail, too much data, could lead to information overload. To deal with this situation our mental systems, including memory, are selective.

⁵⁸⁵ Hefner, *The Human Factor*, 204.

⁵⁸⁶ Michael D. Mumford, Cassie S. Blair, and Richard T. Marcy, 'Alternative Knowledge Structures in Creative Thought: Schema, Associations, and Cases,' in James C. Kaufman and John Baer (eds.), *Creativity and Reason in Cognitive Development*. (New York: Cambridge University Press, 2006), 120.

⁵⁸⁷ Polanyi and Prosch, *Meaning*, 22-45.

⁵⁸⁸ See especially the example in Purves and Lotto, *Why We See What We Do*, 226f. where our visual processes not only change perceived colours but also distort angles between objects.

⁵⁸⁹ *Ibid.*, 39.

⁵⁹⁰ *Ibid.*, 227.

Selectivity in memory emerges as mistakes in laboratory experiments on the workings of memory but ‘in the real world selectivity is both a virtue and a necessity.’⁵⁹¹

Human minds have the imaginative ability not just to select the information to work with at any given time but also to create mental images of future possibilities using and modifying data stored in the memory. In this way we plan future actions and prepare for eventualities which may or may not happen. This ability to construct detailed mental representations of future possibilities is vital for our survival and requires that we have a constructive memory system because ‘in the real world, a memory system that could only copy the information it received would be hopelessly maladaptive. It would also be incapable of invention, imagination, and creative art’⁵⁹² as well as science and technology. The works cited here on vision and memory themselves demonstrate the human creative ability to interpret data, produce theories, and to develop ways of assembling more and better data.

The point is that ‘even the perception of familiar parts of our environment is an imaginative act’⁵⁹³ and the ability of human beings to comprehend the world around them and to act appropriately in it is fundamentally imaginative and creative. That is to say creativity is a common feature of human beings. Jaki’s insistence on limiting creativity to a few individuals obscures this commonality and attempts to restrict creativity to a small subset of Boden’s H-creativity⁵⁹⁴ (H for historical) whereas she clearly recognises that ‘H-creativity presupposes P-creativity’⁵⁹⁵ (P for psychological, i.e. personal). The extent of Boden’s P-creativity goes beyond but includes this basic creativity, common to all human beings, which is that of creating a mental construct of the real world and contemplating future possibilities.

This is not to say that human beings are engaging in fanciful imagining and creating a mental construct that bears no relation to real reality. It is indeed true to say that evolutionary epistemology demonstrates that ‘the information that living organisms get

⁵⁹¹ Cohen, 'Overview: Conclusions and Speculations,' 384.

⁵⁹² *Ibid.*, 385.

⁵⁹³ David J. Bryant, *Faith and the Play of Imagination*, ed. Charles Mabee, *Studies in American Biblical Hermeneutics* (Macon: Mercer University Press, 1989), 203.

⁵⁹⁴ Boden, *The Creative Mind*, 43.

⁵⁹⁵ Margaret A. Boden, 'Computer Models of Creativity,' in Robert J. Sternberg (ed.), *Handbook of Creativity*. (Cambridge: Cambridge University Press, 1999), 351.

from the world is sufficiently accurate to allow for survival and reproduction.⁵⁹⁶ It also follows that human mental constructs are similarly accurate for the same purposes. Indeed they are more than sufficiently accurate because from them flow all human artistic and technological transformations of the world which go beyond the needs of survival. For, as argued above, a creative, constructive memory system is necessary for creative art, science, and technology.

What is being described here, in very simplistic terms, is the development of basic paradigms of human understanding of the world. Kuhn popularised the idea of paradigms in his work which focussed on the advancement of scientific knowledge and hypotheses.⁵⁹⁷ However it has a much wider application to the understanding of how human beings gain knowledge in any area of life, even right at the very basic level of apprehending their surroundings. In this wider context ‘a paradigm is “a coherent and mutually supporting pattern of concepts, values, methods and behaviour” that shapes the way a person looks at the world’⁵⁹⁸ and this idea could be used to understand the development of technology ‘as proceeding within the framework of “paradigms.”’⁵⁹⁹ One such paradigm that has operated during a significant part of the history of technology has been that of human beings as created in the Image of God.

This understanding of the creative role of the human mind in comprehending the world is not to be understood as denying such a possibility to other creatures. However it is human beings who have shown the extent of this inner creativity through the making of tools and artefacts, the building of cultures, and the development of technologies. This relates to the idea in the first creation narrative in Genesis that human beings are made in the image of God because this implies creativity. In this first chapter of Genesis ‘the content of the word *God* . . . has fundamentally to do with God's *creative* activity; so the human vocation to be in God's image is to be modeled on the creative words and actions of God.’⁶⁰⁰

⁵⁹⁶ Van Huyssteen, *Alone in the World?* , 93.

⁵⁹⁷ Kuhn, *The Structure of Scientific Revolutions*.

⁵⁹⁸ Arnold Pacey, *Meaning in Technology* (Cambridge, Massachusetts: MIT Press, 2001), 207.

⁵⁹⁹ Mitcham, *Thinking through Technology*, 134.

⁶⁰⁰ Terence E. Fretheim, *God and World in the Old Testament* (Nashville: Abingdon Press, 2005), 48.

Creativity is not an add-on. It is fundamental to understanding the real world and not just to manipulating it. In the Genesis passage the image of God is linked to human beings having ‘dominion’ (Gen 1.26). Whatever the precise meaning of the word is it entails an ability to comprehend the world over which dominion has to be exercised and that ability is essentially creative. The God-given role of dominion is undergirded by the God-given gift of creativity the first use of which is to comprehend the environment in which human beings are placed before the process of manipulating that environment begins. But the path taken in the development of that manipulation in the process of bringing about modern technological society is not a simple deterministic one, and it is to that path that we now briefly turn.

7.2 Technology is the modern human environment

It was stated above there are good empirical grounds for the objectification of technology. These grounds are simply the different ways in which it seems to dominate people’s lives. In ‘The Technological Society’, originally written in 1954, Ellul observed that

‘It is not only in work that man encounters this transformation. His environment as a whole – everything that goes to make up his milieu, his livelihood, habitat, and habits – is modified. The machine has transformed whatever is most immediately connected with him: home, furniture, food.’⁶⁰¹

Technology has continued to advance ever since. Computers barely existed in those days. Engineers would still use slide rules, log tables, and electro-mechanical calculators in their work even in the late 1960s and beyond. Now many computer controlled systems lay behind the modern person’s experience of the world. So it is even more true to say that in ‘many people’s experience, technology has largely displaced nature in the immediate environment of their lives.’⁶⁰²

The way we experience technology is not just through the acquisition of manufactured artefacts or the use of tools or machines but as comprehensive computer driven systems which integrate different aspects of our relationship to our culture. Everyday items such as televisions and aeroplanes are not simply complicated electronic and mechanical machines; ‘they are complex technological systems consisting of a large range of

⁶⁰¹ Ellul, *The Technological Society*, 326.

⁶⁰² Pacey, *Meaning in Technology*, 130.

different specific technologies, sciences, institutions, legal and financial structures, and so on.⁶⁰³ Buying goods at a supermarket will often not only involve the use of a credit card with all the financial, credit, and banking systems, run on computers, in the background but also a loyalty card. This is connected to a different computerised account which adds up points to be converted to some form of reward and also keeps track of what is bought so that specific tailor-made offers can be made to the account holders. These systems have become part of our lives and we just go along with them when there are no problems and they appear to bring us advantages, but if difficulties arise and, say, our credit card is refused at the checkout we become more aware of their presence and we can feel threatened or intimidated by this unknown and opaque system. It also seems that society is subject to unstoppable constant change driven by technological developments and possibilities. Technology appears to be such that ‘there seems to be little that can be done to check its rapid worldwide spread.’⁶⁰⁴ At the same time we do not look away from technology in order to deal with problems, even those apparently created by technology itself. Usually what we want are better systems, better technologies.

7.3 The Christian Roots of modern Technology

David Noble has characterised this devotion to and belief in technology as a form of religion of which ‘the other-worldly roots . . . were distinctly Christian.’⁶⁰⁵ Such an assertion seems surprising in view of the fact that the early Christians, even after the emperor Constantine made Christianity the official religion of the Roman Empire, were indifferent to the technical advances that had been vital to the expansion and maintenance of that empire. In the 4th century AD the Emperor Julian accused ‘the Christians of ruining the industry of the Empire.’⁶⁰⁶ However there was in the Christian faith an idea that was to become important for the development of technology and that was the idea of reform, ‘the belief in man’s reformation towards his original image-likeness to God’ which was ‘of central importance for early Christian and mediaeval thought and life.’⁶⁰⁷ This idea was initially focussed on the sanctifying work of the Holy Spirit in this life and

⁶⁰³ Bronislaw Szerszynski, *Nature, Technology and the Sacred*, 1st ed. (Oxford: Blackwell, 2005), 63.

⁶⁰⁴ David H. Hopper, *Technology, Theology, and the Idea of Progress* (Louisville, Kentucky: Westminster/John Knox Press, 1991), 73.

⁶⁰⁵ David F. Noble, *The Religion of Technology* (New York: Alfred A. Knopf, 1997), 9f.

⁶⁰⁶ Ellul, *The Technological Society*, 34.

⁶⁰⁷ Gerhart B. Ladner, *The Idea of Reform* (Cambridge, Mass.: Harvard University Press, 1959), 3.

the transformation of the resurrection to eternal life. In the early Church 'to carry reform according to the image of God beyond personal and communal sanctity had seemed to be unnecessary'⁶⁰⁸ so it would take many centuries before this reformation was linked to an improvement in human knowledge and technical ability.

An important historical moment was the introduction of the heavy plough into northern Europe in the latter part of the 7th century AD. This not only provoked social change relating to the distribution of farming land but also marked a change in the relationship between human farmers and the soil in that 'formerly, man had been part of nature; now he was the exploiter of nature.'⁶⁰⁹ What is easily overlooked is the significance of the success of this venture. The subsistence farming of the seventh century AD meant that the predominant focus of society was on agriculture, so the significance of a successful innovation that improves the harvest would have been readily grasped by the community and become part of its understanding of its relationship to nature in the context of a Christian belief in the fallenness of humankind. According to the Garden of Eden story the fall of Adam meant that agriculture, the production of food from the soil, would be difficult with the untamed ground yielding thorns and thistles. (Gen 3:18) The heavy plough means that agriculture is more successful and the burden of work has been eased. Human innovation has led to significant improvement in the material realm.

This is not to say that the concept of the image of God was changed by this one event, but it is to argue that this will have had an impact on the understanding of the relationship between people and nature at a basic level and given evidence of the possibility of human flourishing in the material world as well as the spiritual. It should also be remembered that as less human effort is required to provide the basic requirements of life there is more energy that can be put into cultural, social, religious, and community activities.

In the 8th century AD Alcuin expressed the hope that renewal had actually begun in Charlemagne's empire in the areas of wisdom and knowledge. Behind this expressed hope was 'the doctrine of the image of God to which men's minds are to be reformed.'⁶¹⁰

⁶⁰⁸ Ibid., 423.

⁶⁰⁹ Lynn White Jr., 'The Historical Roots of Our Ecological Crisis,' in Carl Mitcham and Robert Mackey (eds.), *Philosophy and Technology*. (New York: The Free Press, 1983), 262.

⁶¹⁰ Ladner, *The Idea of Reform*, 3.

As human beings increased in wisdom and knowledge so they, it was thought, recovered some part of what was lost in the fall of Adam. It was then in the next century that John Scotus Erigena ‘argued that the useful arts were indeed part of mankind’s original endowment, his God-like image, rather than merely a necessary product of his fallen state.’ In so doing he specifically invested the useful, technical, arts with ‘spiritual significance, as elements of man’s God-likeness, and identified them as vehicles of redemption.’⁶¹¹ Again this was not suddenly to change the whole outlook of the Holy Roman Empire as the holding of such new views was essentially elitist. What the common man or woman made of such things, if they heard about them at all, is not known. However the idea was sown and taken up to bear fruit in the monastic orders of the 12th century AD when ‘the new exalted, spiritualized view of the useful arts truly became the norm, especially among the innovative Cistercians and other Benedictines.’⁶¹²

In the 12th century Hugh of St Victor believed that Adam’s ‘prelapsarian perfection was not solely spiritual, as Augustine had argued, but physical as well.’⁶¹³ This meant that it was possible to work at improving the human physical situation as well as engaging in activities to promote spiritual advance. Effectively the Fall of Adam was seen as a fall not just from moral and spiritual perfection but also from a perfection of knowledge of the material world and therefore the ability to put it to practical use. So it was in this century that ‘the proliferation of new devices – watermills, windmills, mechanisms for metal-forging and ore-crushing, the mechanical clock, eyeglasses, the springwheel – both reflected and reinforced this new sensibility.’⁶¹⁴ The impressive success of all these developments no doubt encouraged the later deistic and remote view of God in which the created order is understood not only as distinct and separate from God but also free from any interference. God, as it were, wound up the mechanism of creation and left it to run and it is now up to human beings to discover how to exploit it for their own benefit.

It has also to be noted that this flowering of the technical arts was independent of any scientific understanding of the world and this state of affairs would continue for centuries. By the end of the fifteenth century the technological superiority of Europe was

⁶¹¹ Noble, *The Religion of Technology*, 16f.

⁶¹² *Ibid.*, 18.

⁶¹³ *Ibid.*, 19.

⁶¹⁴ *Ibid.*, 18.

such that it could fuel a long period of worldwide exploration, conquest, and colonisation in which one of the weaker European states, Portugal, could even manage to forge its own empire including the East Indies on the other side of the world. However the technology that was behind this aggressive expansion ‘was built by pure empiricism, drawing remarkably little support or inspiration from science.’⁶¹⁵ The same was true throughout and beyond Reformation and Counter-Reformation up until the second half of the nineteenth century.

7.4 Reformation and Technology

The Reformation itself undoubtedly reinforced the processes of the disenchantment of nature and the development of the notion of individualism which would lead to the modern self as a ‘buffered self’ in contrast to the ‘porous self’ of medieval times and before. In this buffered self ‘the possibility exists of taking a distance from, disengaging from everything outside the mind.’⁶¹⁶ We have a sense of a clear boundary between the self and what lies beyond so that we can view nature and have a relationship with it from a detached point of view. The buffered self can even ignore the fact that it is part of that natural world which has become an object of its increasingly transcendent thinking. This buffered self, which arises out of the Christian idea of reform, referred to above, in the context of medieval society,⁶¹⁷ encouraged the development of interest in both science and the practical arts. The Reformation had other significant indirect effects on the development of these two areas of human endeavour.

One effect was that it ‘helped to further a change in the attitude towards change.’⁶¹⁸ In the Greek philosophy adopted and adapted by Christian theologians change and decay went hand in hand. Reform links change to improvement. Initially this was improvement in a spiritual sense, but came to be seen in a much wider context in human life. Another effect was that by calling into question received religious authority the Reformation ‘represents a major step in the secularization of modern society – that is the historical shift from ecclesiastical to lay, civil authority governing society.’⁶¹⁹ These two effects

⁶¹⁵ White Jr., 'The Historical Roots of Our Ecological Crisis,' 261.

⁶¹⁶ Charles Taylor, *A Secular Age*, 1st ed. (Cambridge, Massachusetts: Belknap Press of Harvard University Press, 2007), 40.

⁶¹⁷ *Ibid.*, 26-89.

⁶¹⁸ Hopper, *Technology, Theology, and the Idea of Progress*, 50.

⁶¹⁹ McClellan III and Dorn, *Science and Technology in World History*, 208.

worked hand-in-hand as reformation and improvement in society is brought about by changes in government assisted by science and technology. Not that science had much to contribute at that time. It was technology that was ‘a useful instrument for creating cultural spaces in which this (human) flourishing could occur.’⁶²⁰

The lack of a contribution from science is notable because such high hopes were placed on the prospect of scientific discovery and the value such knowledge would have on improving the human situation. Francis Bacon and René Descartes had expressed the view that nature should be exploited for the benefit of human beings. Such ideas were taken up to the extent that in the West since the seventeenth century ‘the notions that science is useful, that science is a public good, and that knowledge is power have ruled as cultural leitmotifs.’⁶²¹ That expectation placed upon science could not be materialised until a later time when science itself had been transformed. In the meantime technology developed without the help of science and indeed the two enterprises remained ‘the largely separate enterprises, intellectually and sociologically, they had been since antiquity.’⁶²²

Thus it was that the industrial revolution was not launched on a wave of new scientific knowledge generated by scientists and their researches into the natural world and its workings. Rather it was a growing technical knowledge of how to do things and how things work. This practical knowledge and understanding was garnered by observant engineers, craftsmen, and artisans who saw opportunities to exploit their inventiveness. They were essentially practical men and not theoreticians. Indeed it was sometimes the case that the inventions they came up with became the focus of attention for scientific work⁶²³. As it was ‘few of them were university educated, and all of them achieved their results without the benefit of scientific theory.’⁶²⁴ In fact the particular social structures that pertained in England, notably the exclusion of religious dissenters from certain aspects of national life including the universities, led to them directing their energies into trade and industry. Not all enterprising business men were dissenters but the non-

⁶²⁰ Brent Waters, *From Human to Posthuman*, ed. Roger Trigg and J. Wentzel Van Huyssteen, *Ashgate Science and Religion Series* (Aldershot: Ashgate, 2006), 47.

⁶²¹ McClellan III and Dorn, *Science and Technology in World History*, 247.

⁶²² *Ibid.*, 266.

⁶²³ *Ibid.*, 290.

⁶²⁴ *Ibid.*, 289.

Anglican section of the population yielded a much higher proportion of inventors and innovators than pure numbers would have suggested as Nonconformists ‘repaid their exclusion from university, local government, . . . by practical education and economic exertion.’⁶²⁵ So even up to the middle of the nineteenth century scientific research was largely irrelevant to the progress of technology. This was two centuries after the death of Newton who, according to Alexander Pope, had been brought into being by God so that nature’s laws might be illuminated.⁶²⁶

7.5 Development of this-worldly Goals

Up to this point in history modern technology is not to be found. It comes into being with the advance and application of mathematics in science and technology and the uniting of classical and Baconian science. For instance Faraday’s research into the electromagnetic field had been more qualitative in approach. James Clerk Maxwell (1831 – 79) took these notions and applied mathematics to them ‘and gave the world the elegant mathematical expressions that describe the field in the form of wave equations’⁶²⁷ named after him. These equations showed that electromagnetic waves might be generated and transmitted and thus opened up the possibility of modern communication technology. By the turn of the twentieth century scientists and engineers had found common ground which allowed a deeper understanding of natural processes involved in technology. In previous centuries science had been dependent on technology for the production of apparatus. Now the boot was on the other foot except that as scientific research sought answers to questions to do with matters well beneath the surface of reality so it needed more and more complex equipment, the Large Hadron Collider⁶²⁸ and its possible successor⁶²⁹ being cases in point. One of the side effects of this mathematical joining of science and technology is that they are removed from the immediate understanding of ordinary people who ‘cannot understand what is happening.’⁶³⁰ As a result both science and technology become

⁶²⁵ Harold Perkin, *The Origins of Modern English Society 1780 - 1880* (London: Routledge & Kegan Paul, 1972), 71.

⁶²⁶ McClellan III and Dorn, *Science and Technology in World History*, 265.

⁶²⁷ *Ibid.*, 306.

⁶²⁸ *Large Hadron Collider*, (Science and Technology Facilities Council, [cited 20th February 2014]); available from <http://www.stfc.ac.uk/646.aspx>.

⁶²⁹ Jonathan Owen, *Beyond Cern: Now Physicists Prepare to Construct the Even Larger Hadron Collider* (The Independent, 2014 [cited 20th February 2014]); available from <http://www.independent.co.uk/news/science/beyond-cern-now-physicists-prepare-to-construct-the-even-larger-hadron-collider-9139495.html>.

⁶³⁰ Coulson, *Science, Technology & the Christian*, 25.

objectified as ‘things’ without regard for the human creativity which underlies both of them or the huge range of diversity to be found in both.

This development of technology hand in hand with science did not happen for its own sake. Sometimes inventions come about through simple curiosity or chance such as Perkin’s synthesis of a permanent mauve dye. This story also points to another significant point in the growth of technology. Perkin made sufficient money as a result of this discovery and his patenting of it that he could retire at the age of 35 in the middle of the nineteenth century.⁶³¹ Patent Law dates from the early seventeenth century and makes it possible for people to have legal rights over their inventions and make money from them. Corporation law allowed for the setting up of limited liability companies which meant that risk could be spread. These kinds of legislation meant not just that people could profit from their ingenuity but also changed the environment in which they worked. If profit could be gained by being ingenious then it was worth coming up with new inventions. So ‘continuous innovation, not conservation, is the source of power in the world that has emerged since the seventeenth century’⁶³² and those innovators in engineering and technology led the way. Shareholders in companies expect dividends from company profits. To avoid being eclipsed by other companies new ideas to make money are needed and so innovation breeds innovation. This of course is not only true of the whole range of technology but also in such matters as banking and financial services in which ill-advised innovation can have far reaching consequences. This constant innovation in so many areas of life is another reason why people feel threatened by technology but it is the commercial aspect of it which is one of the real drivers of change. Another is the desire for military power and yet another is the desire to improve human life especially if profit can be made from it.

This desire to improve human life spawned the idea of progress which came out of the idea of reform referred to above but as applied not just to people but society, even the Church, and the state. This secularised hope emerged out of a Christian heritage which included the ideas focussed on the image of God, millenarian expectations, and eschatology. This ‘collapse of the transcendent axis in modernity’⁶³³ occurred partly as a

⁶³¹ Derry and Williams, *A Short History of Technology*, 543.

⁶³² Hopper, *Technology, Theology, and the Idea of Progress*, 75.

⁶³³ Szerszynski, *Nature, Technology and the Sacred*, 172.

result of the devastating religious wars of the sixteenth and seventeenth centuries and partly from the ‘liberating psychological impact of the Copernican-Newtonian revolution.’⁶³⁴ However it was the evident success of technology in changing and improving lives as well as some positive experience of change in political and social situations that encouraged what Hopper notes as the ‘increasing affirmation of this-worldly goals and purposes in contrast to past otherworldliness.’⁶³⁵ It came to be hoped, even believed, that human beings had the capacity, primarily through reason and the application of science through technology to bring about human fulfilment in an ordered and just society. Because this hope, spawned by ‘the impassioned but unnatural union between an emergent secular materialism and classical Christian eschatology,’⁶³⁶ was a ‘this-worldly’ hope rather than the ‘other-worldly’ hope of Christian eschatology it was open to frustration and disillusion. Historical events such as the aftermath of the French Revolution and then the First World War led to a ‘profound disillusion with the great political hope which helped inspire the original belief in Progress – the idea that by eliminating ignorance and a corrupt social order, humanity could accomplish its own fulfilment.’⁶³⁷ However technology was at hand to take over carrying this mantle of hope in progress.

7.6 Technological Systems

From the turn of the twentieth century technology begins to appear as the monolithic structure it is now treated as having. The final step in the process of arriving at modern technology was the development of systems. Henry Ford is perhaps best known for the innovation of the moving production line for the manufacture of his Ford T model car. However this was but the final part of an integrated system which included mines for producing raw materials, railways for transport, blast furnaces to make iron, as well as glass and other component manufacture.⁶³⁸ Another system builder was Frederick Winslow Taylor who treated workers as if they were parts of machines with the aim of designing production systems ‘involving both men and machines that would be as efficient as a well-designed, well-oiled machine.’⁶³⁹ Machines can be designed and

⁶³⁴ Hopper, *Technology, Theology, and the Idea of Progress*, 101.

⁶³⁵ *Ibid.*

⁶³⁶ Bauckham and Hart, *Hope against Hope*, 45.

⁶³⁷ Hopper, *Technology, Theology, and the Idea of Progress*, 74.

⁶³⁸ Hughes, *American Genesis*, 186, 209f.

⁶³⁹ *Ibid.*, 188.

maintained to do repetitive work to a high standard and identical machines can be built from the same blueprint but people are less predictable because of their individual personality traits and have to be controlled by some means in order to get consistency of output. This is another reason people feel themselves to be at the mercy of the technological system which these days applies to many areas of life and work and not just manufacturing industry.

Many system builders were no doubt motivated by the desire for profit and power in their 'drive to order, centralize, control and expand technological systems over which they presided,'⁶⁴⁰ but there was also a certain intellectual fascination in solving complex problems which brought a different reward, 'human delight in "sweet" problem solving.'⁶⁴¹ Whatever the various motivations of the system builders their work has transformed the world as a range of different technologies, including automobile, aviation, electrification, entertainment and so on, have formed 'intricate and interlocked systems that spread across the world from their North American and European roots to transform utterly how people live.'⁶⁴² It is not technology as such that has driven this transformation, it is the human motivation that has used and pushed technology that has caused it to happen. There is indeed something different about our attitude to life and the world in which we live that is different to that experienced by people just two hundred years ago. Ellul has identified this as modern 'technique' which has 'no common denominator'⁶⁴³ with that of yesterday. But technique is not the same as technology even though it is intimately bound up with it. Technique is governed by the desire to use our rationality to achieve certain ends and depends on the development of the 'buffered self' as referred to earlier. Technique is evidenced in the development of large scale systems which confront modern human beings in their everyday lives and which appear to be beyond normal comprehension.

7.7 Creativity and monolithic Technology

The purpose of the last section has been to show how it is that technology has developed in western culture, in the first instance, to the point at which it appears to be an objectifiable 'it'. Looking backwards over a historical development can give that

⁶⁴⁰ Ibid., 185.

⁶⁴¹ Ibid., 237.

⁶⁴² McClellan III and Dorn, *Science and Technology in World History*, 339.

⁶⁴³ Ellul, *The Technological Society*, 146.

development a deterministic appearance particularly as the combination of technique and technology gives the impression of the inevitability of future innovations. Whilst people might feel threatened or intimidated by modern technology there is no sense of total rejection of it and the systems within which it operates. Better technology is still the solution to the problems that technology creates and it has an allure which ‘is captivating, mesmerizing us with the latest gadgetry.’⁶⁴⁴ The speed at which new technological developments - computers, the internet, mobile phones, ipods, and ipads etc. – have swept the world, and not just the West, demonstrates how deeply ingrained is the idea that technological novelty is the same as progress. The idea of political and social progress has not disappeared but its possibility has been largely transferred to developments in technological systems. This idea of progress through technological systems has now become so ingrained in human minds as a way of understanding life ‘that it would indeed be a frightening day in which all faith in it was lost.’⁶⁴⁵

Modern technology tends to hide the fact that it is based on human creativity working in cooperation with human desires to improve, systematise and control human life, whether those ends are achieved or not. Whilst human technique may have changed radically over the centuries, particularly through the adoption of secularised this-worldly goals, the creativity that underlies it is the same and gives continuity to technology itself. Even if it is true that there has been a fundamental change in technique ‘it is in no way clear that premodern and modern technology are not the same.’⁶⁴⁶ This social, commercial, and military juggernaut-like reality of our age still depends on human creativity both to provide the innovation that it feeds on, and to solve the problems that previous innovations created in their wake. People may be nervous about where all this is leading as ‘technological advance seems to be independent of human direction’⁶⁴⁷ and the human race has lived on the edge of self-inflicted nuclear extinction, but there have been real benefits. These can be seen in such areas as medicine, communications, transport, as well as the general increase in variety in many aspects of life for increasing numbers of people over the world. Through innovation human beings have explored and are exploring the possibilities for life in our physical world. It also proves to be best way for companies to

⁶⁴⁴ Ronald Cole-Turner, 'Science, Technology, and Mission,' in Max L. Stackhouse, Tim Dearborn, and Scott Paeth (eds.), *The Local Church in a Global Era*. (Grand Rapids: William B. Eerdmans, 2000), 100.

⁶⁴⁵ Taylor, *A Secular Age*, 717.

⁶⁴⁶ Mitcham, *Thinking through Technology*, 138.

⁶⁴⁷ Florman, *The Existential Pleasures of Engineering*, 59.

survive in the modern competitive world. ““Innovate, innovate!” . . . is the best strategy for individual (commercial company) survival, and it is a strategy from which we all, as consumers and citizens, have benefited immensely.’⁶⁴⁸

7.8 The Domination of Nature

The ambivalence expressed above raises the question as to whether things could be done differently and better. One of the features of industrial and other technologies is the way the human element is reduced. During the industrial revolution ‘machines that led to displacement or deskilling of labor paid off so well that they came to be seen as the goal of any inventor or engineer interested in productive machinery.’⁶⁴⁹ Such an approach leads to a devaluing of ordinary human beings. One difference in the approach to technology is to try to make processes more people orientated. The effect of this is to make design processes, for example, more participatory in style with designers involved with the wider community instead sitting at their electronic drawing boards in isolation.⁶⁵⁰ Whilst this approach might soften the edges of some processes it can still be carried out in a context which values human society above and to the detriment of the ecological system in which we exist. The idea of human domination and exploitation of nature has historical connection with the Christian doctrine of the Image of God interpreted as a matter of human mastery over nature which is seen as existing for the sole benefit of humanity. White has argued that ‘modern technology is at least partly to be explained as an Occidental, voluntarist realization of the Christian dogma of man’s transcendence of, and rightful mastery over, nature’⁶⁵¹ and even the introduction of the heavy plough involved violence for the way it ‘attacked the land.’⁶⁵² The interpretation of ‘dominion’ (Gen.1.26) by ‘mastery’ which involves exploitation and violence undoubtedly lay behind the development of modern science and technology. Nature has to be forced to give up its secrets in a way that makes Francis Bacon’s assertion ‘Nature must be taken by the forelock’⁶⁵³ seem quite mild. This dominating, even violent, construal of the Image of God is not supported by the biblical text when the nature of the creator God is considered. This was considered in part in an earlier chapter on the

⁶⁴⁸ Paul Ormerod, *Why Most Things Fail* (London: Faber and Faber, 2005), 240.

⁶⁴⁹ Pacey, *Meaning in Technology*, 209.

⁶⁵⁰ *Ibid.*, 213.

⁶⁵¹ White Jr., ‘The Historical Roots of Our Ecological Crisis,’ 264.

⁶⁵² *Ibid.*, 262.

⁶⁵³ Quoted in McClellan III and Dorn, *Science and Technology in World History*, 247.

Biblical creation narratives. We now return to that issue in the wider Old Testament context.

7.9 God and Violence in Creation

The question of whether violence and exploitation belong to the nature of God is highly significant for understanding the nature of the Image of God. If God is intrinsically violent then this would serve as permission, at the very least, for human violence. In the context of the present study this would bear upon the development and use of technology by human beings. In the interpretation of the first creation narrative in Genesis in a previous chapter I have argued that the writer is silencing the voices from other nearby cultures which see violence as an ontological, pre-existing reality and speak of it in terms of a struggle between some primordial power and God.

The nearest influence on the people of Israel will have been that of the Canaanite people with their worship of Baal. In the Ras Shamra texts this warfare is expressed, for instance, in the following:

‘Then soars and swoops the mace in the hand of Baal,
Even as an eagle in his fingers.
It smites the head of Prince Sea,
Between the eyes of Judge River.’⁶⁵⁴

There appears to be a clear reference to this in Psalm 89: 25 where God says of David

‘I will set his hand on the sea
and his right hand on the rivers’

However the context has been shifted away from creation to a guarantee of success for David as King of Israel. But this Psalm, as mentioned above, is one of only three texts that Middleton accepts has a reference to creation-by-combat. This is because of earlier verses, 9-12, which read:

‘You rule the raging of the sea;
when its waves rise you still them.
You crushed Rahab like a carcass;
you scattered your enemies with your mighty arm.
The heavens are yours, the earth also yours;
the world and all that is in it – you have founded them.
The north and the south – you created them.’

Middleton interprets these verses as a reference to ‘God’s victory over the primordial forces of chaos’⁶⁵⁵, but the complexity of the passage is indicated by the present and past

⁶⁵⁴ Thomas, ed., *Documents from Old Testament Times*, 129.

tenses mixed together and the reference to ‘Rahab’ which is identified with Egypt in Psalm 87:4 and Isaiah 30:7.

When the people of Israel came out of Egypt in the Exodus the Red Sea and River Jordan both presented obstacles that they had to cross. Moses and Joshua were their leaders at the two crossings respectively. When the people encountered the Canaanites and their culture the mythical depiction of Baal defeating the waters will have had a significant resonance with them because of their experience, even though the context of the myths was very different. The imagery will have been absorbed quite naturally in the process of the Israelites expressing their own faith and experience, but the mythical background forms a threat to their understanding of God and creation that has to be overcome. In the process, by and large, the allusions are transferred to ‘historical enemies whom God has vanquished or will vanquish . . . or to the Red Sea through which the Israelites passed at the exodus.’⁶⁵⁶

An interesting light is cast on this process by the prophet Habakkuk in chapter 3 where he recalls God’s victories of the past in saving the people of Israel. Creation-by-combat language hovers in the background, but in verse 8 the prophet asks the question:

‘Was your wrath against the rivers, O Lord?
Or your anger against the rivers,
or your rage against the sea,
When you drove your horses,
your chariots to victory?’

The connection between this passage and the Baal myth above becomes even more striking when the alternative readings of ‘river’ for ‘the rivers’ and ‘sea’ for ‘the sea’, are taken into account. But the question asked serves to drag the reference away from a creation myth to God’s activity in history. It is then quite clear that the development of Israelite thought is away from conceiving there to be pre-existent destructive and chaotic forces with which God has to struggle violently in order to establish God’s creation. This confirms the conclusions drawn in the earlier chapter which investigated the first creation narrative in Genesis. However, this still leaves the question of how we are to understand God acting violently and destructively in the world.

⁶⁵⁵ Middleton, *The Liberating Image*, 248.

⁶⁵⁶ *Ibid.*, 238.

7.10 Does God enjoy violence?

In the Genesis narrative God does not respond violently to the sin of Adam and Eve even though death was the punishment declared before the event. Cain's murder of Abel does not incur death or other violent punishment. It is not until Genesis chapter 6 that God is roused to destroy human kind and the other creatures with a flood because

‘the wickedness of human kind was great in the earth, and that every inclination of the thoughts of their hearts was only evil continually So the Lord said, ‘I will blot out from the earth the human beings I have created for I am sorry that I have made them.’
(Genesis 6:5-7)

This is striking because a moral reason is put forward for God acting in this way. In the ‘Atrahasis Epic’ the reason given for the flood is that the noise of human beings is disturbing the Gods: ‘Oppressive has become the clamor of mankind. By their uproar they prevent sleep.’⁶⁵⁷ But in Genesis God is, as it were, drawn into this action because of the wickedness of humankind, not just their actions but their thoughts also. The human beings are not bringing to the earth the sort of dominion producing blessing and fruitfulness that God desired. God determines to act but is unable to inflict the full punishment because there is Noah, ‘a righteous man, blameless in his generation’ (Genesis 6:9), so the story of the flood and the ark unfolds.

It appears as if there is a tension in God who desired by creative acts to bring blessing to the earth through God's agents, human beings, but instead wickedness has come through the same agents abusing the powers and freedoms granted by their creator. This cannot be allowed to continue, but the way of completely stopping it cannot be followed because there is still some good, some righteousness, amongst human beings. The same tension arises later when Abraham is deliberately taken into God's confidence whilst God is on the way to investigate and punish Sodom and Gomorrah. The reason for this is because Abraham ‘shall become a great and mighty nation, and all the nations of the earth shall be blessed in him.’ (Gen.18.18) God allows Abraham not only to know what is going on but also to challenge God over likely outcomes. Abraham's appeal is over justice; ‘Far be it from you to do such a thing, to slay the righteous with the wicked, so that the righteous fare as the wicked! Far be that from you! Shall not the Judge of all the earth do what is just?’ (Gen.18.25) God confirms to Abraham that in responding to the wickedness found

⁶⁵⁷ Pritchard, ed., *Ancient near Eastern Texts Relating to the Old Testament*, 104-06.

in God's creation it is justice that will be the determining factor not irrational anger. The righteous will not be destroyed with the wicked.⁶⁵⁸ Abraham is not simply soliciting an assurance from God on this matter. It is as if 'Abraham is Yahweh's theological teacher'⁶⁵⁹ and God has to learn how to deal with humankind when they act contrary to God's purposes.

A tension arises in the exodus narrative when the people have made the golden calf. God says to Moses; 'now let me alone, so that my wrath may burn hot against them and I may consume them; and of you I will make a great nation.' (Exodus 32:10) But Moses, with various arguments, challenges God to 'turn from your fierce wrath; change your mind and do not bring disaster on your people.' (v.12b). Other examples of Moses interceding with God can be found in Exodus 32:31-32, 33:15-16, and Numbers 11:10-15. God is clearly portrayed as being open to consider possibilities that emerge from the creation, particularly from human beings who are created to have a special place in that creation, so 'the most extraordinary thing about these prayers is that in each case, Moses prevails.'⁶⁶⁰ God is shown to being in internal tension when interacting with creation in the light of the evil that human beings bring to pass in the place of blessing for that part of creation within their dominion.

The prophet Jeremiah speaks judgement against various nations and not only Israel. With the latter comes a promise: 'Jacob shall return and have quiet and ease, and no-one shall make him afraid.' (Jer.46:27) But curiously, and without further explanation, a number of the other nations upon whom judgement is coming are promised restoration. After an extended pronouncement of judgement against Moab, Jeremiah declares: 'Yet I will restore the fortunes of Moab in the latter days, says the Lord.' (Jer.48:47) Similar statements occur with regard to Egypt (Jer.46:26), the Ammonites (Jer.49:6) and Elam (Jer.49:39) but not for the Philistines, Damascus, Kedar and Hazor, and Babylon. The apparent arbitrariness displayed in these pronouncements is disconcerting. There is certainly something unsettling about the thought that God's mind has not been fully made up. However the faith of the Old Testament does not understand God as being

⁶⁵⁸ Westermann, *Genesis 12-36: A Continental Commentary*, 293.

⁶⁵⁹ Brueggemann, *Genesis*, 168.

⁶⁶⁰ Walter Brueggemann, 'A Shape for Old Testament Theology, 2: Embrace of Pain,' in Patrick D. Miller (ed.), *Old Testament Theology: Essays on Structure, Theme, and Text*. (Minneapolis: Fortress Press, 1992), 31.

arbitrary, even if God's ways are inscrutable, for the two poles of the tension are identified. One is the holiness of God: 'Your eyes are too pure to behold evil, and you cannot look on wrongdoing.' (Hab.1:13) and the other is God's steadfast love: 'my steadfast love shall not depart from you, and my covenant of peace shall not be removed.' (Isaiah 54:10) These two poles are sometimes celebrated together as in verses 4 and 5 of Psalm 33:

'For the word of the Lord is upright,
And all his work is done in faithfulness.
He loves righteousness and justice;
The earth is full of the steadfast love of the Lord.'

The tension comes to a particularly acute point in the prophecy of Hosea as God's inner turmoil, so to speak, is expressed. God loves Israel but this love has been met with faithlessness and this merits God's wrath.

'How can I give you up, Ephraim?
how can I hand you over, O Israel?
.....
My heart recoils within me;
my compassion grows warm and tender.
I will not execute my fierce anger;
I will not again destroy Ephraim;
for I am God and no mortal,
the Holy One in your midst,
and I will not come in wrath.' (Hos.11:8-9)

Anger is being internalised by God who feels the consequences. In the process God is transformed and this 'changes the calculus with reference to Israel.'⁶⁶¹ Following a recapitulation of the long history of the sin and rebellion of God's people, God then speaks of healing love and blessing:

'I will heal their disloyalty;
I will love them freely,
I will be like the dew to Israel;
They shall again live beneath my shadow,
they shall flourish as a garden;

As God feels internally the suffering that punishment, however much merited, will bring about, the realisation comes that simply punishing wrongdoing is not achieving God's

⁶⁶¹ Ibid., 40.

purposes and so the ‘conventional reading of earth and heaven is nullified and God assumes a new posture towards the covenant partner.’⁶⁶²

A different part of this process of God reflecting on the wider consequences of God’s actions comes in the prophet Ezekiel. In exile some of the elders of Israel come to the prophet to find out if there is any word from God. The reply starts: ‘Why are you coming? To consult me? As I live, says the Lord God, I will not be consulted by you.’ (Ezek.20:3) There then follows a stylised narrative of the wrongdoings of the people, from the time of the exodus, in which God’s thoughts of venting anger upon the disobedient people are expressed. This happens three times and each time it is followed by an internally considered response which stays God’s hand. (Ezek.20:8-9, 13-14, 21-22). The third time reads as follows:

‘Then I thought I would pour out my wrath upon them and spend my anger against them in the wilderness.
But I withheld my hand and acted for the sake of my name, so that it should not be profaned in the sight of the nations, in whose sight I had brought them out.’

This reasoning was that of Moses: ‘Why should the Egyptians say, “It was with evil intent that he brought them out to kill them in the mountains, and to consume them from the face of the earth.”’ (Ex.32:12)

7.11 God’s apparent ambiguity towards what has been created

God is not being portrayed as some sort of divine judge reacting to human action in a legalistic way. Nor is God portrayed as a wrathful and vengeful divinity. God is displayed as having to consider appropriate actions in the light of desired outcomes in a humanly understandable way. One side of God’s holy character is provoked by the sin and disobedience of human beings into acting against them in destructive punishment. But another side changes the resulting behaviour of God either because of the effect there would be on divine relationships with other nations, whom God intends to bless, or because of the internal pain the action causes to Godself because of the relationship of love between God and the people of Israel. There is an ambiguity about God who lives with the question about what sort of God to be. In the Old Testament God is deciding

⁶⁶² Ibid., 41.

‘whether to be ‘like the other gods’ or to be a holy God,’⁶⁶³ where holiness is to do with love and compassion.

In the earlier chapter ‘Mapping the Relationship between Theology and Technology’ George Blair⁶⁶⁴ was criticised because of his application of the characteristics of immutability and impassibility to God. When this is done it is difficult to make sense of the witness of the Old Testament to the character of God as reviewed above and the Incarnation of the Son of God and his suffering on the cross as witnessed to in the New Testament. However these ideas do tend to lie at the back of our thinking about what God is like. We imagine that throughout human history, with all its changing circumstances, the God we make contact with is always the same. We do not imagine that in some way what we do affects and changes God. The idea of an unchanging God is appealing. You know where you are with such a God. The idea of living with a God who, whilst interacting with us and the rest of the created order, is in the process of making up the divine mind is rather unnerving. However the Biblical writings witness to this divine mental activity being brought about by the interaction of God’s qualities of love and faithfulness with their opposites in the created order, especially amongst human beings. It is not being claimed here that the essential nature of God is being changed but ‘the content of His thoughts, what His concerns are about’⁶⁶⁵ changes as God’s creativity activity brings new things into being. Further change takes place in this area of God as the created order, including human beings, brings about novelty through the freedom afforded by the creator God. At the deepest level there is no change in God and there is no ambiguity in God’s relationship with the created order because it is founded in love.

In the chapter 4 above the fact of God’s creation being a free act of God was highlighted. That is to say, God freely decided in love to create the cosmos, being under no compulsion to do so. The decision to create the cosmos involved other decisions such as those concerning the qualities it will have. Will it be, for instance, a place of free decisions and independent actions? Because of the affirmative decision made to this particular question there then arises the issue of how God will relate to this creation. As what sort of god will the cosmos experience God? More particularly the situation can be

⁶⁶³ Ibid., 44.

⁶⁶⁴ Blair, ‘Faith Outside Technique.’

⁶⁶⁵ Mark I T Robson, *Ontology and Providence in Creation* (London: Continuum, 2008), 202.

sharpened up by pointing out that God is faced with problem of what sort of god to be if this created order, using the freedom granted to it in love, decides not to do things in God's way. This is not to suggest that God is arbitrary but to acknowledge, that in the face of human sin and evil, God has to wrestle with the available options and possibilities, given the constraints of previous decisions concerning the nature of the cosmos, in deciding how to achieve God's desired outcomes.

7.12 Image of God as a Paradigm to direct Technology

This brings us back to the understanding of the image of God as a paradigm behind the historical reality of the development of technology. The paradigm behind God's creativity is love. The paradigm behind human creativity expressed in technology includes self-centred, domineering, and coercive elements linked to the understanding of the image of God. In the light of the witness of the Old Testament text this has been shown to be mistaken. This view is supported by the New Testament in which Jesus affirms that he 'came not to judge the world, but to save the world.' (Jn. 12.47) God's love is such that rather than destroy this world which has become perverted by sin and evil God purposes to redeem it and bring it to the fulfilment that God has purposed for it since the beginning. This salvation is achieved in a non-violent manner through Christ,

'who, though he was in the form of God,
did not regard equality with God as something to be exploited,
but emptied himself, taking the form of a slave,
being born in human likeness.
And being found in human form,
he humbled himself and became obedient to the point of death –
even death on a cross.' (Phil. 2.6-8)

Through the incarnation of Christ, and the taking up of his human life into the Godhead, God experiences first-hand what it is like to live as a human being in the finite context of God's created order. Acting in this manner to effect redemption for the whole created order and not just human beings (Rom. 8.19-23) God affirms the goodness of the whole creation project and the decision 'to have human persons become collaborators with him in achieving the divine project of mutual relations of love.'⁶⁶⁶ The goal of this project is described in the New Testament as 'the kingdom of God' and 'the kingdom of Heaven.' This kingdom 'is not from this world' (Jn. 18.36) because its citizens do not fight to

⁶⁶⁶ John Sanders, *The God Who Risks* (Downers Grove: InterVarsity Press, 1998), 12.

protect their king and the king uses self-sacrifice rather than coercive force to establish the kingdom.

The shape of modern technology belies its origins in a Christian understanding of the world and the place of human beings in it. Had the paradigm of the image of God contained a collaborative and loving understanding of God, rather than a domineering and coercive one, history would no doubt have been different for ‘the technological transformation of nature, no less than science, is a contingent product of the West’s specific sacral history.’⁶⁶⁷ However we are not in a position to re-run the tape of history to see if the outcomes would be different. The fact that we have arrived at this point in history with all its problems suggests that either God did not do practice runs beforehand or the alternatives would be even worse. God deals with the consequences of the creative freedom given to the created order in collaboration with that order because ‘God has freely chosen to rely upon that which is not God’⁶⁶⁸ to achieve the divine purposes. In all this the gift of creativity which God has given to human beings finds its place. This gift is given so that people may both understand that which God has created and explore the possibilities of it through a range of human activities including technology.

In an earlier chapter it was shown that the dark side of creativity, evident in the uses of technology and the consequences of those uses, was not inherent in creativity itself. The dark side emerges from such things as human ignorance and motivation interacting with creativity. Human creativity is a feature of God’s creation and comes within God’s perception of creation as ‘very good.’ (Gen. 1.31) In practice it has been shown how modern technology owes its existence to human creativity but controlled by a mistaken notion of human beings bearing the image of God. The results of modern technology cannot be assumed, therefore, to be in line with God’s purposes. The very positive approaches of Fudpucker, Coulson and Hefner to modern technology, outlined in chapter 2 above, need to be treated with caution. Fundamentally human technology can properly be regarded as part of God’s creative gift to humanity, but specific outcomes of that technology do not show the character of God’s love and therefore are not in keeping with God’s purposes. However the unintended consequences of well-intended technology as well as the complex systems within which we live our daily lives, mean that it is difficult

⁶⁶⁷ Szerszynski, *Nature, Technology and the Sacred*, 52.

⁶⁶⁸ Fretheim, *God and World in the Old Testament*, 270.

to unravel technology into what fits God's purposes and what does not. God has given the gift of creative technology to human beings but we do not actually understand what God's purposes are. The Garden of Eden story (Gen. 2.4 – 3.24) expresses the feelings of not understanding the world into which we are placed and estrangement from the creator with the consequent ignorance of God's purposes. It is to those eternal purposes and how human creativity expressed in technology will fit into them that we turn in the next chapter.

Chapter 8

The Purposes of God

In the previous chapter the development of western technology has been explored from the point of view of its dependence on the human creative instinct as well as its particular trajectory through history. It has been noted that there have been various influences on this development including the Christian ideas of reform and human beings as created in the image of God, however these ideas are not fixed but have also changed over time, not always in ways compatible with their Biblical roots. The dominion afforded to human beings over creation in the first creation narrative in Genesis has been readily interpreted as dominance and even domination, making human beings the centre of the creation story. Historically God has often been thought of in terms of a 'feudal king whose person was invulnerable, whose will was irresistible and whose rule dominated everything.'⁶⁶⁹ Through this entry point violence and coercion as modes of human action find permission leading to the accusation that 'modern technology is at least partly to be explained as an Occidental, voluntarist realization of the Christian dogma of man's transcendence of, and rightful mastery over, nature.'⁶⁷⁰ It has been shown, however, in the previous chapter and in an earlier one on the creation narratives that the ground for such an understanding of human action is cut away when it is seen that the Biblical text portrays God in a different fashion. God is shown as acting in a permissive fashion as creation progresses rather than in a dictatorial manner. God invites what is first made, sea and earth, to participate in the next stage. Made in God's image there is no basis for human action other than that found in God's creative activity.

To express the same thought in a different way, human beings should 'hack as God would hack.'⁶⁷¹ Garner's unusual thought depends on a definition of 'hacking' that doesn't carry the negative connotations of cyber-crime for 'within technoculture hacking might be seen as "an appropriate application of ingenuity" that brings something new into existence, whether a temporary fix to a problem or an elegant creation.'⁶⁷² Because

⁶⁶⁹ Sanders, *The God Who Risks*, 189.

⁶⁷⁰ White Jr., 'The Historical Roots of Our Ecological Crisis,' 264.

⁶⁷¹ Stephen Garner, 'Hacking the Divine,' *Colloquium* 37, no. 2 (2005): 194.

⁶⁷² *Ibid.*, 188.

of God's work in creation it is possible to imagine God as a technologist⁶⁷³ bringing into being the cosmos as a technological system. Human technology is then a reflection, however inadequate, of God's technology to be carried out after the manner of God's activity. The expressions 'subdue' and 'have dominion' (Gen. 1.28) do invest the notion of the image of God with power but it is to be 'exercised as God exercises power. . . . There is nothing here of coercive or tyrannical power, either for God or for humankind.'⁶⁷⁴

8.1 Human Beings are not the ultimate goal of God's creativity.

The focus on human beings created in the image of God has also resulted in an understanding of human beings as the pinnacle of God's creative activity with what came before as simply serving this goal of creation. The creation of creatures who can engage in a relationship with their creator is perceived as the primary purpose of God. The significance of this for God is heightened by the fact that God took a risk in giving human beings the freedom and freewill necessary for them to have a relationship with God based on love. The incarnation of the Son of God and the redemption of the world through his suffering speak of an intense divine commitment to the human race. The danger in all this is that human beings become what really matters in God's creation and the rest becomes unimportant. This way of thinking has been encouraged by the Platonic understanding of reality which has pervaded Christian eschatological thinking at times. In this indivisible souls, which alone can exist in God's Eternal Now, are solely possessed by rational human beings. As a result all the rest of God's creation, afflicted by temporality and imperfection, becomes 'useless and irrelevant.'⁶⁷⁵ It is true that God desires all human beings to 'come to the fullness of Jesus'⁶⁷⁶ but that is not to side-line the rest of creation and deny it a fuller place in the purposes of God. The goal of the divine project is not simply 'to produce people who reflect the Trinitarian love in all their relationships'⁶⁷⁷ The goal concerns the entire creation and will only become evident when God's purposes are fulfilled in God's new creation.

⁶⁷³ Cheek, 'Theology & Technology: An Exploration of Their Relationship with Special Reference to the Work of Albert Borgmann and Intelligent Transportation Systems', 34-45.

⁶⁷⁴ Brueggemann, *Genesis*, 32.

⁶⁷⁵ Wilkinson, *Christian Eschatology and the Physical Universe*, 115.

⁶⁷⁶ Sanders, *The God Who Risks*, 170.

⁶⁷⁷ Ibid.

It has been properly objected that this focussing on human beings, even in the Genesis story, as the pinnacle of God's creation 'violates the spirit of the Earth-orientated story that precedes it,'⁶⁷⁸ however within the whole of the creation story it is important that the specific and special role of human beings is not lost. Two particular points need to be made. The first is that the focus on the creation of human beings is emphasised in the text. The word 'create' occurs three times in Gen. 1.27 and this action is preceded by divine deliberation. But even here caution has to be exercised because human beings are created, according to this stylised narrative, on the sixth day, the same day in which the land creatures are created so establishing human solidarity with them. The second point is that it is only after the creation of human beings in their God-likeness that everything is declared to be 'very good' (Gen. 1.31) in God's eyes. This 'very good' verdict does not mean that God's creation had arrived at some pinnacle of static or cycling perfection to which 'there was nothing to add.'⁶⁷⁹ Indeed the ascription of God-like powers of subduing and dominion speaks against such a view. Westermann notes that the word 'good' has the sense of 'appropriate', being 'good for' some purpose. 'The world which God created and devised as good is the world in which history can begin and reach its goal and so fulfil the purpose of creation.'⁶⁸⁰ There is more work to be done and God has set human beings, as divine representatives, to be responsible for at least some of that work.

The point is that God's purposes transcend human beings and all that they can achieve. At the same time human creative activity is for God a significant element of the process involved in achieving these purposes. Nowhere in the Bible is there given a simple understanding of what God is about. In the teaching of Jesus the focus is on the announcement of the Kingdom of God. This is what Jesus is inaugurating in his life, death, resurrection, and ascension. However the words 'the Kingdom of God' are not a specification which allows us to determine exactly what it will contain. Indeed the instinctive human understanding of the kingship of God as including the power to coerce,

⁶⁷⁸ Norman C. Habel, 'Geophany,' in Norman C. Habel and Shirley Wurst (eds.), *The Earth Story in Genesis*. (Sheffield: Sheffield Academic Press, 2000), 47.

⁶⁷⁹ Ellul, 'Technique and the Opening Chapters of Genesis,' 125.

⁶⁸⁰ Westermann, *Genesis 1-11: A Continental Commentary*, 166.

in the manner of human kings, is subverted by the deliberate act of self-emptying performed by Jesus Christ. (Phil. 2.6-8)

One clue to understanding what God's purposes may be is to be found in the act of blessing which God confers on the creatures that have been created. For instance in Genesis 1.22 where we read that 'God blessed them, saying, "be fruitful and multiply..."', the words 'be fruitful and multiply' are clearly explaining what the blessing actually is. In other words 'the blessing which God confers on the creatures which he has created is the power to reproduce, multiply and fill the earth.'⁶⁸¹ This suggests strongly that what God wants is abundance and variety in the created order. This view is supported by the extraordinary and exuberant picture of creation 'with its festive impertinence to humanity'⁶⁸² that is expressed by God in response to the challenge of Job. (Job 38-41) This contrasts sharply with the eschatological thoughts of physicists such as Freeman Dyson where life might be reduced to an interstellar cloud of dust or of free electrons and positrons.⁶⁸³ The definition of life that Dyson uses here was laid down by Tipler in giving a physicist's understanding of life as information processing. This bleak definition is acknowledged to be not what people think of as involved in life but it is claimed that at the level of physics all human activities 'can be shown to be information processing.'⁶⁸⁴ This way of thinking of physics as the only real science and all the rest being stamp collecting⁶⁸⁵ is mistaken not least when considering life. The coding of DNA molecules, the basis of life on this planet, whilst governed by the underlying physics cannot be predicted 'on the basis of biochemistry or microphysics alone.'⁶⁸⁶ Genuine novelty exists even when it is in accord with the basic laws of physics.

8.2 Space for creativity

It will be useful to consider the idea of 'creative space' at this point, not necessarily in terms of physical space but as a metaphorical concept applying to the many different

⁶⁸¹ Ibid., 140.

⁶⁸² Steiner, *Grammars of Creation*, 40f.

⁶⁸³ Freeman J. Dyson, 'Life in the Universe: Is Life Digital or Analogue,' in George F. R. Ellis (ed.), *The Far-Future Universe*. (Radnor: Templeton Foundation Press, 2002), 144.

⁶⁸⁴ Frank J. Tipler, *The Physics of Immortality* (New York: Anchor/Doubleday, 1995), 126.

⁶⁸⁵ The quotation 'All science is either physics or stamp collecting' is attributed to Ernest Rutherford see *Ernest Rutherford*, ([cited 27th March 2014]); available from http://en.wikiquote.org/wiki/Ernest_Rutherford.

⁶⁸⁶ George F. R. Ellis, 'Natures of Existence,' in George F. R. Ellis (ed.), *The Far-Future Universe*. (Radnor: Templeton Foundation Press, 2002), 320.

contexts in which creativity happens. Many different types of creative space exist. For example within human experience the accepted rules of a language create a space which can be explored to produce works of prose and poetry. This space is bounded by these rules but creative activity can and does push at this boundary as has been discussed in chapter 3 above. The boundary is a human construction and is itself contingent on previous human experience and creative activity in the development of the language as a means of communication. The same applies to music where it can also be seen how the creative invention of musical notation transformed musical space to allow much more creatively complex works of music to be written.⁶⁸⁷ The boundaries, as it were, control what can happen but do not determine what is actually created. The boundaries, in these cases, are malleable and change with time through their dynamic interaction with what is created. As a result it becomes possible to create things that would have been effectively impossible in an earlier time. An example of this in music is that sounds we think are ‘gorgeous would to the ears of a medieval bishop have sounded like the dreadful howling of the dogs of hell.’⁶⁸⁸ What God created was a bounded creative space. All creaturely creative activity takes place within this space. The boundaries are established by God and are not amenable to human alteration in the way that the cultural boundaries, such as those referred to in the case of language and music, are. Within the overall creative space with its God determined boundaries human beings have developed temporal cultural boundaries which place their own limitations on human creativity.

The boundaries of God’s created creative space include, for instance, rationality and mathematics. The physical laws of the universe that we discover are also part of the boundary of the creative space which is God’s creation. The properties of sub-atomic particles, the laws of thermodynamics, and the properties of chemical elements all form part of the boundary of this creative space but ‘the specific character of the world is open to chance.’⁶⁸⁹ It might even be conjectured that God has set boundary conditions which mean that only a universe that can yield a huge amount of variety and abundance along with creative loving relationships can prosper. Be that as it may, God has certainly so ordered matters that there exists an abundance of possibilities for life to express itself

⁶⁸⁷ Howard Goodall, *Big Bangs: The Story of Five Discoveries That Changed Musical History* (London: Vintage, 2001), 8-43.

⁶⁸⁸ *Ibid.*, 36.

⁶⁸⁹ Robson, *Ontology and Providence in Creation*, 180.

within the physical world, also operating within God's creative space, as it changes in time. The geology of this planet is not fixed as there are massive forces in action changing its physical characteristics with time. The climate has varied immensely over time as well. As a result a huge variation in the form in which life can exist is to be found in the present world and this is added to by the forms which are witnessed to in the fossil records from earlier times. All these forms of life depend/depended on the physical laws but were not necessitated by them. The ecosystem itself determines what can be successful in terms of creaturely characteristics at any given time. As a result similar outcomes occur by different routes. An example of this sort of creative convergence in biological evolution is the similarity of the sabre-tooth tiger of the northern hemisphere to a sabre-toothed marsupial, related to kangaroos and opossums rather than to big cats, that thrived in an isolated South America.⁶⁹⁰

Biological evolution can be used as a model for understanding the growth and development of technology as seen, for example, in the emergence of the modern airliner following from the first successful aeroplane built by the Wright Brothers. (see Figs 1.1, 1.2, and 1.3 p.194f) The change that has happened over the space of less than 100 years is properly seen as a series of small creative steps that cumulatively form a colossal leap. As discussed in chapter 1 above many ideas have failed to succeed. One such is Bert Rutan's Starship design for Beech (Fig.1.8 p.196) which was not acceptable to customers because it was too innovative. Other ideas, such as Barnes Wallis' swing-wing concept did not proceed at the time because of the current financial and political situation. The environment decided which creative ideas ultimately flourished. This is similar to the 'slow, cumulative, one-step-at-a-time, non-random survival of random variants that Darwin called natural selection'⁶⁹¹ that resulted in the development of life as we know it. However caution should be exercised over the use of such an analogy because technology is part of human culture and its transmission involves one generation teaching the next what it has learned. In other words human culture exhibits the transmission of acquired characteristics rendering it more like a Lamarckian type of evolution. This is because in human culture in general and technology in particular there is a cognitive, interactive element which is lacking in the story of Darwinian evolution.

⁶⁹⁰ Simon Conway Morris, *The Crucible of Creation*, 1st Paperback ed. (Oxford: Oxford University Press, 1998), 202-04.

⁶⁹¹ Dawkins, *Climbing Mount Improbable*, 70.

For human creativity the specific physical laws of nature as we encounter them form part of the boundaries of the creative space we inhabit. They are the context which forms the real open space which is explored by human creativity. This physical world is also the space within which life has explored its possibilities before human beings appeared on the scene. In the context of human creativity the human understanding, or lack of it, of the nature of the physical world and the place of human beings within it also helps to define the space and places further constraints on what is actually created. So when human beings effectively define their own relationship to the physical world in terms of viewing it as being there solely for human purposes this has great significance for the consequences of human creative activity. This means that the beginning of the development of Western technology can be understood as an exploration of the possibilities inherent in the physical world constrained and driven by the conceptual paradigm of the image of God. But the operating paradigm has been a distorted form of the Biblical one so that the focus has become that of human beings exploiting the physical world however they wish for their own ends. As a result the modern scientific-technological project has become ‘a kind of new creation, a remaking of the world, as though humans had the creative power of God and the creative wisdom of God.’⁶⁹² In other words at least one part of the transformation that will occur with God’s new creation will be the establishing in the human mind of a paradigm in keeping with the creative motivation of God. For there to be creative activity there has to be real open space within these boundaries which can be explored.

8.3 God’s risk in creation

In order for the work to be carried out God has granted humans the creative ability and the freedom to do it with a degree of independence from God. In granting these gifts God has taken a risk. The risk is partly that God’s human creatures will choose to live and work contrary to God’s expectations. In the world of aircraft technology risk is reduced by thoroughness in the research and design processes which result in the production of drawings, blueprints, which define in the greatest detail possible the shape of every component and precisely how they all fit together. In this way the performance of a particular aircraft is ensured to be as predicted and if a component needs to be replaced an identical one can be manufactured. This level of management of detail is essential in

⁶⁹² Bauckham and Hart, *Hope against Hope*, 38ff.

human commercial technology but it is not the way that God has chosen. Perhaps it is possible for God to plan and micromanage a world in its four dimensions that fulfils some divine purpose and specification. However God has not chosen this way for ‘God has freely chosen to rely upon that which is not God to engage those purposes.’⁶⁹³ God has not set up a machine to achieve God’s purposes in an automatic fashion but rather has given space and permission for what has been created to play its part in fulfilling those purposes. Supremely they are to be achieved by human persons who are created with the qualities needed to achieve those ends and the freedom within which to do it. Such freedom, because it is genuine, allows for the possibility that humans will not follow God’s ways but will proceed in a way that is contrary to that desired by God.

The risk that God took was not that the whole project being undertaken would be put in jeopardy and face annihilation rather it was the risk of the suffering that God would undergo in order to redeem a wayward creation through love. God’s commitment to the created order is such that rather than allowing it to slip away into futility and nothingness God ‘upholds and confirms it as that which He has made and comes to redeem’⁶⁹⁴ with all the cost and pain that involves. The suffering and death on the cross of Jesus Christ, the Son of God, exemplifies the risk that God took in allowing freedom and creativity to be part of the created order. The risk was not simply that of the disobedience of creatures. By granting even a limited form of independence to the creation God took ‘the risk that the autonomy of his creatures would make him seem to be nonessential and even non-existent.’⁶⁹⁵ This risk has certainly played out within the context of modern materialistic science in which a creator is needed neither to begin nor sustain the creative process. In this situation human beings have to find an alternative goal for their creative activities to that centred in the purposes of God. It has been argued above that starting from a defective understanding of the image of God the current goal of human technological creativity has become centred on human aspirations. This also results in human beings no longer having established boundaries about what it means to be human. This meaning is now to be found in what ‘humans will themselves to be.’⁶⁹⁶ This situation may be further modified as some of the downsides of human technology become more evident in human

⁶⁹³ Fretheim, *God and World in the Old Testament*, 270.

⁶⁹⁴ Thomas F. Torrance, *Space, Time and Incarnation* (London: Oxford University Press, 1969), 67.

⁶⁹⁵ Wolfhart Pannenberg, *Systematic Theology*, trans. G. W. Bromiley, 3 vols., vol. 3 (Grand Rapids: William B. Eerdmans, 1998), 643.

⁶⁹⁶ Waters, *From Human to Posthuman*, 49.

consciousness. The ecological issues of pollution, global warming, and the diminution of finite resources have created a situation where there is a greater realisation of the interdependence that exists between human beings and the rest of life on our planet. This may be tending towards ‘a more porous understanding of the human-non-human boundary.’⁶⁹⁷

This boundary, as manifested in the ‘buffered self’ which can disengage ‘from everything outside the mind,’⁶⁹⁸ referred to in the previous chapter, has been of great significance for the development of modern science and technology. As this boundary is a human cultural creation it is not surprising that it might change in interaction with the results of the creativity it controls, in much the same way as the rules of language change in response to actual usage as referred to above. This change of boundary and guiding principle will not take us back to the situation that existed before the rise of the ‘buffered self’ for too much practical knowledge has been gained and the dominant Christian monotheism has ‘so radically shaped Western culture that its departure leaves us in a very different landscape than the one from which we started.’⁶⁹⁹ The human context has changed significantly so that human beings appear to be less at the mercy of the environment and more the directors of it than used to be the case half a millennium ago. The word ‘appear’ is significant because storms, tsunamis, earthquakes, volcanoes, disease, and death continue to significantly affect human life. Looking forward no solution has yet been found to the problem of the heat death which modern science predicts to be the future of the universe and which appears to mock all human ideas of progress and meaning as does the apparently unlikely alternative scenario of a ‘Big Crunch’ end to our universe.⁷⁰⁰ In the face of these possibilities the interpretation of the human effort to understand the universe as ‘one of the few things that lifts human life a little above the level of farce, and gives it some of the grace of tragedy’⁷⁰¹ seems like whistling in the dark to lift ones spirits.

⁶⁹⁷ Szerszynski, *Nature, Technology and the Sacred*, 177.

⁶⁹⁸ Taylor, *A Secular Age*, 38.

⁶⁹⁹ Szerszynski, *Nature, Technology and the Sacred*, 9.

⁷⁰⁰ Wilkinson, *Christian Eschatology and the Physical Universe*, 12-22.

⁷⁰¹ Stephen Weinberg, *The First Three Minutes* (London: Flamingo/Fontana Paperbacks, 1984), 149.

8.4 God's New Creation

8.4.1 God's decisive action

Whatever the future shape of the boundaries that govern the trajectory of technology Christian hope is not grounded in such human possibilities. The notion of God acting within the created order to bring about a new creation occurs in the Old Testament, but very much as expressing faith in the creator God who will bring about peace, justice and prosperity for the People of Israel. In the light of God's action through the life, death, resurrection, and ascension of the Son of God, Jesus Christ, this hope is transformed on a universal scale as for the entire creation. This hope is not because human beings are expected to be able to change the boundaries of the creative space in which they are set. The focus of Christian hope is in the action of God whose purposes for the creation do not include sin, evil, and suffering. The God who freely in love brought this creation into being and who freely in love redeemed it through Jesus Christ's act of self-sacrifice is also free in love to transform it. Because of God's committed, steadfast love towards this created order the transformation of new creation will take place. In some ways this might appear not to be an act of love because creation appears to have no choice. I am reminded of a scene in which a two year old child continued to approach an escalator despite the calls of a patient father. In the end the father, out of love, came and physically removed the child from danger. Decisive action is not ruled out by love and may indeed be spurred on by it.

Sanders reminds us that 'love must not be construed as powerlessness, and almightiness must not be understood apart from love.'⁷⁰² Oord's theory of 'essential kenosis'⁷⁰³ fails the first of these tests as the God portrayed cannot, by virtue of God's own character, act in any way that is coercive. This means that the assigning of a beginning to creation becomes problematic because God calls creation into being in what might be regarded as a coercive manner. God is seen as having to act unilaterally before having a created being to hold in a loving relationship. Oord's solution is to identify God's relationship with the cosmos as one in which God is always, eternally, creating so eliminating a starting point. Similarly the final eschatological victory for God cannot be achieved by coercion either.

⁷⁰² Sanders, *The God Who Risks*, 190.

⁷⁰³ Thomas Jay Oord, *The Nature of Love: A Theology* (St Louis, Missouri: Chalice Press, 2010), 117-57.

God is prepared to wait. God ‘never gives up.’⁷⁰⁴ The claim that this demonstrates God’s power and love does not work because it does not take into account the Biblical witness to God taking decisive action. The word ‘coercion’ is being used to deny God the ability to act unilaterally and decisively. Oord’s proposal fits in with a Biblical text such as 2 Pet 3.9 ‘The Lord is not slow about his promise, as some think of slowness, but is patient with you, not wanting any to perish, but all to come to repentance.’ However this is followed in verse 10 by, ‘but the day of the Lord will come like a thief.’ Jesus refers to future decisive action by God in the face of the suffering of the last days when ‘for the sake of the elect those days will be cut short.’ (Matt.24.22) In Jesus’ words is reflected the Old Testament view of God who brought Israel ‘out of the land of Egypt with great power and with an outstretched arm.’ (2 Kings 17.36) It is correct to say that ‘coercion - in the sense of being totally controlled by others - is incompatible with love’⁷⁰⁵ but it is wrong to define God’s acts of creation and new creation in this way. When God takes decisive action it is to open up possibilities for creative flourishing rather than close them down which is the result of coercion. The child referred to above was simply told, ‘We are going this way.’

The way that God has decided we are going is that of new creation in which the old is transformed rather than replaced. This transformation is for the whole created order but the evidence for it is the resurrection of Jesus Christ. It was this event that the Apostles proclaimed and not some new religion, philosophy, or ethics. These latter things did come in time but only as they grew out of the understanding of the event of the resurrection of Jesus perceived as a decisive act of God. As an event in history this act has to be examined and questioned as such. Tipler insists that it has to ‘meet the standards not only of history but also of physics.’⁷⁰⁶ However his conclusion that alleged witness reports about UFOs as well as the ‘notorious N-rays delusion’ provide adequate grounds for treating the appearances of Jesus as a ‘collective hallucination’⁷⁰⁷ does not constitute a serious analysis of the event in its context.

⁷⁰⁴ Ibid., 156.

⁷⁰⁵ Ibid., 27.

⁷⁰⁶ Tipler, *The Physics of Immortality*, 312.

⁷⁰⁷ Ibid., 310.

8.4.2 The Historical Bodily Resurrection of Jesus

It cannot be claimed that the people of those days were ready to believe such a story as that of the resurrection. In the Greek culture of the Roman Empire the generally accepted view was that any afterlife was not embodied and when you are dead there is no way back for ‘everybody knew there was in fact no answer to death.’⁷⁰⁸ This lay behind the confusion in Athens when Paul was accused of proclaiming foreign divinities because ‘he was telling the good news about Jesus and the resurrection.’ (Acts 17.18) Rather than understand that he was speaking of someone returned from the dead in bodily form the instinctive assumption was that he was speaking of two divinities, one called ‘Jesus’ and the other ‘Resurrection’. In Jewish culture it was different for there was a belief in a general resurrection as witnessed to by Martha’s response to Jesus that she knew her deceased brother Lazarus ‘will rise in the resurrection on the last day.’ (Jn. 11.24) However there was no belief that resurrection ‘would happen to one person ahead of everyone else’⁷⁰⁹ and certainly not to the person who had clearly been shown, by being crucified, not to be the Messiah, whom it had been hoped was ‘the one to redeem Israel.’ (Lk. 24.21) The message of the resurrection of Jesus was deeply counter-cultural in its day and needed some compelling evidence for it to be accepted by the followers of Jesus in the first place. Their expectations of Jesus as the Messiah had been shattered when Jesus was crucified. The compelling evidence was the empty tomb and their meetings with the risen Lord. It is this situation of shattered expectations and not just sorrow at the death of a friend that Tipler fails to recognise in his ‘collective hallucination’ proposal.

The resurrection of Jesus has left many other ripples in the pond of historical events such as those investigated by Wright⁷¹⁰ and Moule.⁷¹¹ For the purposes of this thesis it can simply be affirmed that the resurrection of Jesus was an event in history caused by the action of the creator God which witnesses to and heralds Gods forthcoming act of new creation. This new creation will be a transformation of God’s original creation for God loves it, is committed to it, and is determined to see it brought to fulfilment even at the cost of the suffering and death of God’s son, Jesus Christ. Indeed the cross and resurrection of Jesus Christ is ‘the fixed point by reference to which we may chart ... the

⁷⁰⁸ Wright, *Surprised by Hope*, 47.

⁷⁰⁹ *Ibid.*, 51.

⁷¹⁰ *Ibid.*, 43-87.

⁷¹¹ Moule, *The Phenomenon of the New Testament*, passim.

fulfilment of God's redemptive will for the whole creation.⁷¹² The resurrection of Christ reveals God's ability to turn human evil into good as the occasion of Christ's suffering is the opportunity to bring salvation to humankind and his being raised to new life is the foretaste of God's new creation. God's 'inexhaustible self-giving love'⁷¹³ is this capacity of God not only to absorb evil and its consequences but also to transform them. This is what creates the possibility of inadequate human creative activity in deformed technology being incorporated into God's kingdom.

In the face of a tendency to spiritualise and psychologise the resurrection stories told in the New Testament it is important to emphasise that as far as the first generations of Christians were concerned the resurrection of Jesus was a physical, bodily event. God was understood to have transformed Jesus physical body and not replaced it with something else. The accounts witness to continuity as well as discontinuity. The Biblical resurrection appearances set forth the physical, bodily nature of Jesus' post resurrection being. St. Luke has Jesus holding and breaking bread (Lk.24.30) in the narrative of the road to Emmaus. Later, when he suddenly appears amongst the gathered disciples he eats a piece of broiled fish in order to convince them he is not a ghost. (Lk.24.39-43) In St John's Gospel the physicality of Jesus' resurrection body is also quite clear. There was a body that Mary could have held onto otherwise there was no point in Jesus telling her not to. (Jn.20.17) Thomas was offered the possibility of touching Jesus' wounds after he had suddenly appeared amongst the disciples despite all the doors being shut. (Jn.20.26-27) In this instance it is also shown that Jesus' resurrection body is in continuity with his crucified body even though he was not necessarily immediately recognisable as is indicated by both the Emmaus road story and the meeting with Mary referred to earlier in the paragraph. On the day of Pentecost Peter's speech (Acts 2.14-36) clearly indicates the belief that 'Jesus' physical body did not decay ...but received new life.'⁷¹⁴

8.4.3 The Resurrection to come in God's New Creation

St Paul had to deal with the problem of some Christians in Corinth not believing in a future resurrection for Christians. This disbelief was entirely in line with their cultural background. He presents in the 15th chapter of his first letter to them 'a long argument in

⁷¹² Torrance, *Divine and Contingent Order*, 139.

⁷¹³ John V. Taylor, *The Christlike God*, 2nd ed. (London: SCM Press, 2004), 138.

⁷¹⁴ N. T. Wright, *The Resurrection of the Son of God* (London: SPCK, 2003), 455.

favour of a future *bodily* resurrection⁷¹⁵ based on the bodily resurrection of Jesus. When he contrasts the current ‘physical body’ with the future ‘spiritual body’ (1 Cor.15.44) he is still talking about what we would call today a physical body but what animates it is changed from the normal human life force to God’s spirit so that ‘if there is a soul filled body, there is also a spirit filled body.’⁷¹⁶ St Paul also employs the ideas of continuity and discontinuity when he uses the image of a plant growing from a seed, both of which have a body chosen by God with transformation as the connection between them. St. Paul’s argument is based on the fact that ‘Christ has been raised from the dead’ (1 Cor.15.20) and his ‘picture of the Christian resurrection body is modelled closely on what he thinks was and is true of Jesus.’⁷¹⁷ In other words beginning with a belief in the bodily resurrection of Jesus the first Christians believed that God will ultimately bring about a transforming new creation, including the bodily resurrection of Christian believers, which is ‘not the creation of another reality over against the old reality but is the transformation of the old reality.’⁷¹⁸

This new creation was not just about the resurrection of Christians to some new form of life. God’s interests and purposes go beyond the human beings who are important to God in achieving those purposes. In line with this ‘the early Christians ... believed that God was going to do for the whole cosmos what he had done for Jesus at Easter.’⁷¹⁹ It is because God maintains a love of, and care for, God’s creation that the future new creation is to be a transformation of the old and not an annihilation of it. The importance of this is that ‘if transformation, rather than destruction, awaits the natural order, then the material matters.’⁷²⁰ This is why St. Paul concludes his argument for the future resurrection of Christian believers with the words, ‘be steadfast, immovable, always excelling in the work of the Lord, because you know that in the Lord your labour is not in vain.’ (1 Cor.15.58) God’s purposes go beyond, but include, the present reality of the created order in which we are involved. The model of transformation helps us to

⁷¹⁵ Ibid., 314.

⁷¹⁶ Ibid., 356.

⁷¹⁷ Ibid., 348.

⁷¹⁸ Paul Tillich, *Systematic Theology*, Combined ed., 3 vols., vol. 3 (Digswell Place, Welwyn, Herts: James Nisbet & Co, 1968), 442.

⁷¹⁹ Wright, *Surprised by Hope*, 104.

⁷²⁰ McLeish, *Faith and Wisdom in Science*, 163.

comprehend ‘both continuity and discontinuity between creation and new creation can be held together’⁷²¹ and this is first demonstrated in the resurrection of Jesus Christ.

Continuity and discontinuity between original and new creation is shown in the new heaven and new earth of chapters 21 and 22 of Revelation at the end of the Bible. Continuity here is not just with God’s initial creative activity in terms of precious stones, trees and the river but also with human creative technological activity through the presence of a city, New Jerusalem, as well as ‘the glory and honour of the nations’ (Rev.21.26) brought into it as discussed in chapter 4 above. Discontinuity is revealed in the absence of pain, suffering and death. The sun and moon are no longer needed to provide light and there is ‘no temple in the city’ (Rev.21.22), i.e. no humanly created places of worship. This discontinuity is a result of a deeper one in that ‘the home of God is among mortals,’ (Rev.21.3) an astonishing statement in view of the tendency of modern Christians to believe that in the afterlife they will go to heaven. This passage speaks of God coming to live with people in a new creation rather than people going to heaven to live with God. In other words new creation is a place fit for God, ‘where righteousness is at home,’ (2 Pet.3.13) and not simply a better place for human beings to inhabit. There is an echo here of Isaiah’s prophecy that ‘the earth will be full of the knowledge of the Lord as the waters cover the sea’ (Isa.11.9) in which it appears that God’s being will flood the entire cosmos which has been ‘designed as a receptacle for his love.’⁷²² This language is dangerous because space and time do not exist apart from the bodies and forces that fill them. ‘Space and time are not receptaclesbut are functions of events in the universe and forms of their orderly sequence and structure.’⁷²³ Consequently space and time have to be understood in relational terms and it is these manifold relationships that will be transformed according to God’s purpose and be renewed in accordance with the characteristics of love which form the Trinity. In this way new creation becomes a place fit for God.

8.4.4 Preparing for New Creation

In preparation for this future the Bible speaks of judgement and it is in this way that 2 Pet.3.10-13, a key passage appearing to represent a sharp discontinuity between the

⁷²¹ Wilkinson, *Christian Eschatology and the Physical Universe*, 36.

⁷²² Wright, *Surprised by Hope*, 113.

⁷²³ Thomas F. Torrance, *Space, Time and Resurrection* (Edinburgh: The Handsel Press, 1976), 130.

present order of things and the new creation, is best interpreted. This passage talks about the heavens set ablaze, being dissolved, and passing away and the elements being dissolved and melted with fire. When reading this and other similar passages it is important not to let our present knowledge and understandings inject meanings that are alien to the context. We readily think of the Earth as a spherical planet in the solar system which will one day be enveloped by an expanding sun and destroyed. We unconsciously incorporate that image into our interpretation of the burning up referred to in this passage. However it needs to be remembered that ‘in the Bible, the earth is not a planet’⁷²⁴ and care is needed in seeking understanding. In Verse 10 ‘εὑρεθήσεται’ (‘will be found’), referring to ‘the earth and everything that is done on it,’ presents difficulties of understanding in its context and ‘seems to be devoid of meaning’⁷²⁵ resulting in many suggested emendations to the text. However, within the context of the judgement theme of 2 Pet.3, the best interpretation is that ‘these things will be discovered or found out by God.’⁷²⁶ It is also significant that where reference is made to the flood at the time of Noah, this act of God’s judgement was a cleansing of evil rather than a total annihilation of the created order and a restarting from the beginning. The focus of the fire of judgement is the ‘destruction of the godless’ (2 Pet.3.7) in preparation for new heavens and a new earth where ‘new’ is best understood as ‘renewed.’ In this way an apparent discontinuity between old and new creation is tempered with an underlying continuity.

Another aspect of the preparation for the carrying out of God’s new creation is that of the second coming or *parousia* of Jesus Christ referred to in 1 Cor.15.23 and 1 Thess 4.13-18. In the latter passage it might appear that at Christ’s second coming he will gather up all Christians, those who have died as well as those still alive, and take them off to heaven as in popular understanding. However the text does not say that. What it does say is that ‘we will be with the Lord for ever’ (1Thess.4.18) without specifically specifying where this will be. Wright helpfully elucidates the background to this metaphor as being the visit of a Roman emperor to colony or province when the Roman citizens would come out to meet and welcome him and then escort him to the city.⁷²⁷ Viewed from this

⁷²⁴ Karen Strand Winslow, 'The Earth Is Not a Planet,' in Thomas Jay Oord (ed.), *Creation Made Free* Kindle ed. (Eugene, Oregon: Wipf and Stock, 2009), loc 508.

⁷²⁵ Bruce M. Metzger, *A Textual Commentary on the Greek New Testament* (London: United Bible Societies, 1971), 706.

⁷²⁶ Wilkinson, *Christian Eschatology and the Physical Universe*, 71.

⁷²⁷ Wright, *Surprised by Hope*, 145.

background it is clear that the saints are caught up to meet their Lord in order to escort him to that part of his domain which is the earth.

What is quite clear in all this is that God will transform the whole created order according to the loving purpose that brought about its beginning. This transformation will involve judgement in which sin and evil is cleansed away. The redemption that Christ wrought for humanity through the cross and resurrection means more than bodily resurrection for his followers for ‘the creation waits with eager longing for the revealing of the children of God.’ (Rom.8.19) The reference here is back to the story of the judgement of Adam and Eve and their expulsion from the Garden of Eden as narrated in the 3rd chapter of Genesis. As argued in chapter 4 above the cursing of the earth was a consequence of the rebellion of Adam and Eve rather than a way of involving the earth in their punishment. Humankind cannot bless the earth and encourage its flourishing because of humanity’s fractured relationship with the creator God, but with the transformation of new creation it ‘will be set free from its bondage to decay and will obtain the freedom of the glory of the children of God.’ (Rom.8.21) In the light of this eschatological consummation it will finally be seen clearly that God’s sixth day verdict of ‘very good’ (Gen.1.31) on all that had been made is justified.⁷²⁸

8.5 New Creation validates human action in the present

This new creation will be a place not only for redeemed humanity but also fit for God. The old creation with its physicality and relationships, including the creative activities of human beings, will be purified, transformed, and inhabited by God in ways that are beyond our present understanding. God’s actions through Jesus Christ confirm God’s commitment to this order and so validate our commitment to it. It is not for us to be seeking release from this physical reality but as part of God’s family we should be working in it for God’s kingdom. As Wright has argued, ‘what you do with your body in the present matters, because God has a great future in store for it.’⁷²⁹ Human technology fits into this context for it comes about as a result of God’s gift of creativity to humanity. In the first place this gift allows us to comprehend the created order in which we live and then it enables us to generate ideas of what new things might be done as well as being able to create the means of doing them. Human technology is limited by the boundaries

⁷²⁸ Pannenberg, *Systematic Theology*, 645.

⁷²⁹ Wright, *Surprised by Hope*, 205.

that are set around the creative space that is God's creation but the impulse to pursue it 'comes to man as a gift from God. Material enterprise is not to be shunned; it is to be pursued energetically, but with the service of God always kept uppermost in mind.'⁷³⁰

This is then an encouragement to all those engaged in our modern technological enterprise and not just the engineers and technologists themselves. This enterprise, with all its downsides, has come into being because of God's gift of creativity to human beings made in God's image. This gift is given so that human beings can share in the development of the created order as it moves towards its fulfilment according to the purposes of God. Lack of knowledge, sin, and will to power mean that the results of human technology will often appear to be questionable in the limited light that we have concerning God's actual purposes. DeLashmutt, in his critique of 'technological essentialism' notes that it 'implies technology is somehow beyond redemption' and escape from it is 'through the avoidance, rather than the transformation, of technology.' He argues that 'a theology of technology must assert that technology, like all creation, can benefit from the offer of justification and grace.'⁷³¹ We can therefore anticipate the redeeming power of God through Jesus Christ transforming technology, as a human activity, that is fit for God's Kingdom.

Will there be a place in God's new creation for medical technology including helicopters used as air ambulances and can there possibly be a place for nuclear weapons technology, stealth bombers, and remotely controlled weapons systems? If, in our resurrection bodies, we can move about the renewed creation as Jesus did in this world following his resurrection will there be a place for bicycles, cars, trains, boats, and aircraft? It is easier to ask these questions than to even guess answers because the future changing of the boundaries to God's creative space, such as changing the relationship between time and matter and the defeat of death, mean that it is impossible for us to envisage God's future possibilities.

8.6 Technology led by Love, Humility, and Caution

However we are encouraged to live and act in the hope that the God who raised Jesus Christ from the dead will raise to life our mortal bodies and the appropriate lifestyle is

⁷³⁰ Florman, *The Existential Pleasures of Engineering*, 112.

⁷³¹ DeLashMutt, 'Sketches Towards a Theology of Technology: Theological Confession in a Technological Age', 114f.

governed by love. It may well be that a decision to follow such a path will affect the sort of activities, technological and otherwise, that a person engages in. Wright's list of some of the activities that '*will last into God's future*'⁷³² such as 'teaching, building hospitals, digging wells' etc. may well be engaged in by some through the providing of appropriate technology. However in the end the value of our activities 'will be revealed with fire, and the fire will test what sort of work each has done.' (1 Cor.3.13) It will be for God to judge and determine which products of human creativity will be incorporated into the new creation and how they will fit through God's transforming love. If God's purposes include a desire for abundance, variety, and flourishing, as has been suggested above, then we may be surprised by what God includes and how it fits together. In the meantime a Christian view of technology as being part of God's purposes will encourage us to be motivated by love in all our doings and one way this will be expressed will be in the form of humility.

It is easy for human beings to become overconfident especially when we appear to exercise significant power and new discoveries and developments excite our imaginations further. A major problem with any new technology is that of unforeseen consequences. These can arise through not knowing or disregarding how this new thing may change the environment and even human behaviour. This is a result of a heady mix of lack of knowledge, wilful ignorance, sin, and the will to power. Consequently there is uncertainty attached to any new technology or the development of an existing one for 'their future costs are never clear at their introduction.'⁷³³ Therefore humility, one of the aspects of love with which Christians should clothe themselves (Col.3.12), is also a human quality, often lacking, which should underlie human technological development. Human technology results from the decision of God to create human beings in the image of God and is founded upon God's gift of creativity. However we are not God and the gift, used in love, also needs to be used in humility expressing itself in caution.

8.7 God's new creation as a place of creativity

It has been shown that technology has a place as a creative human activity in God's creation which will, through God's transforming love, be part of God's new creation.

⁷³² Wright, *Surprised by Hope*, 205.

⁷³³ Hopper, *Technology, Theology, and the Idea of Progress*, 126.

This leaves open a final question as to whether there will be new creative activity, divine, human or otherwise in God's coming kingdom?

It has been argued that God's original creation which was declared to be 'very good' was not a static perfection. It was, rather, the springboard for further creative activity to take place within the creative space with its particular boundaries that God had brought into being. The fulfilment of this original creation will be in God's eschatological new creation which has been heralded by the resurrection of Jesus Christ. Is that the end of creativity? Taking into account God's apparent desire for variety and abundance the answer that strongly suggests itself is that what is to be ushered in is a new era of creativity involving human beings but with different overall boundaries including redeemed and sanctified human motivation. This answer is strengthened when it is considered how important creativity itself is to human flourishing. Popular views of eternal life in heaven as restful bliss for disembodied minds, which is '*nonsensical*,'⁷³⁴ or renewed bodies, which would be totally boring, simply do not adequately convey the extraordinary nature of God's creative love. If God is creative in God's eternal Trinitarian relationships, as has been argued in chapter 4 above, it is inconceivable that in the fullness of God's kingdom in the new creation all creativity will cease, especially for human beings who are renewed in the image of God. Rather as 'genuine human beings'⁷³⁵ we will continue in some way with a mandate for the flourishing of God's creation. As Wright has expressed it,

'There will be work to do and we shall relish doing it. All the skills and talents which we have put to God's service in this present life – and perhaps too, the interests and likings we gave up because they conflicted with our vocation – will be enhanced and ennobled and given back to us to be exercised to his glory.'⁷³⁶

Jenson puts the question of future creativity rhetorically,

'will there be no jewellers or goldsmiths in the Kingdom? And will the achievement of their lives provide no matter for eternal interpretation by Jesus' love? That feast of "rich food . . . of well-aged wines strained clear,"

⁷³⁴ Margaret Boden, 'Artificial Intelligence and the Far Future,' in George F. R. Ellis (ed.), *The Far Future Universe*. (Radnor: Templeton Foundation Press, 2002), 217.

⁷³⁵ Wright, *Surprised by Hope*, 212.

⁷³⁶ *Ibid.*, 173.

(Is.25.6) will it have no taste? Will there be no cooks or vintners in the Kingdom? Or even connoisseurs?⁷³⁷

Even here with mention of ‘cooks and vintners,’ let alone ‘jewellers and goldsmiths,’ there is abundant scope for ‘picturing the non-existent into existence’⁷³⁸ which is at the heart of human creative technology. Wright’s comment that he does not know ‘what musical instruments we shall have to play Bach in God’s new world, though I’m sure Bach’s music will be there,’⁷³⁹ opens up further possibilities for technological enterprise to create new instruments to play new music as well as old. Why emphasise Bach, delightful and uplifting as his music is? Perhaps the wild harmonies of Lutoslawski’s ‘Paganini Variations’ and the driving rhythms of Nyman’s ‘MGV’ will herald explorations of the musical possibilities of the new creation to the glory of God.

8.8 Aeronautical Creativity yielding Service and Worship

The main part of the introductory first chapter above was an exposition of creativity in the aircraft industry. If ‘what can indeed be the object of idolatrous worship becomes for the mind of faith the means to achieve a service of God’⁷⁴⁰ in what ways can this creativity be used to the glory of God. On this earth potential uses are readily seen as aircraft are used by organisations such as the Missionary Aviation Fellowship to bring the Christian gospel and medical aid to remote parts of the world. Helicopters serve as air ambulances and freight aircraft are usually the fastest way to bring relief supplies to disaster stricken areas of the world. With this potential here and now, there will be ways to glorify God with this technology in the new creation even through worship.

The RAF aerobatic display team, Red Arrows, include in their displays what is now a signature manoeuvre. In this two aircraft trace out with smoke trails an image of a heart before a third jet traces an arrow through the middle. (Fig.8.1 p.208) In this way they symbolise and celebrate love, which Christians believe is the defining quality of God.

⁷³⁷ Robert W. Jenson, *Systematic Theology*, 2 vols., vol. 2 (New York: Oxford University Press, 2001), 352.

⁷³⁸ Hefner, *Technology and Human Becoming*, 45.

⁷³⁹ Wright, *Surprised by Hope*, 220.

⁷⁴⁰ John Heywood Thomas, 'The Problem of Defining a Theology of Culture with Reference to the Theology of Paul Tillich,' in Richard W.A. McKinney (ed.), *Creation Christ and Culture*. (Edinburgh: T. & T. Clark, 1976), 273.



Fig.8.1 Red Arrows 'Heart' manoeuvre.

From <http://www.rafbf.org/files/vapour-trail-red-arrows-heart-maneuvre-604.jpg>.

In the entrance lobby of the EAA Airventure Museum in Oshkosh, Wisconsin, there is suspended from the ceiling a group of three Christen Eagles in formation. (see Fig.8.2 p.209) These aircraft are single engine aerobatic biplanes which used to put on formation displays before they were retired to their present location. The formation they are in can best be described as an upward and outward burst. When I described this formation to John Fielding, a friend who was a professor of aeronautics at Cranfield University, his response was, 'You mean, like a prayer?'

Aerobatics gives great pleasure and joy to many people, not least the pilots, as the possibilities of movement in the air are explored and celebrated. Sometimes the manoeuvres seem almost impossible or breathtakingly dangerous bringing thrills to watching crowds. Where better to start imagining how aviation may be caught up in the glory of God in this world and the world to come?



Fig.8.2 Christen Eagles at the EAA Museum, Oshkosh, Wisconsin – ‘like a prayer’
From <http://www.brech.com/np/aviation/EAA.html>.

Chapter 9

Conclusion

From the outset what has been sought in this thesis is a way of developing a theological understanding of technology which is faithful to the author's understanding of the Christian Gospel and his experience of technology. This has been done in a culture where the ubiquity of technology is coupled with people's ambivalence towards it and where it 'has rarely been thematised as a matter of theological reflection.'⁷⁴¹ The direction of the path that has been traced out is summarised in the following paragraphs.

9.1 Creativity at the Heart of Technology

The starting point is a clear demonstration of human creativity being at the heart of technology through a range of examples in the history of aviation. This creativity is evidenced in numerous ways including the initial solving of the question of how we might fly, the methods of production, and the development of new materials. Creativity is used to address on-going questions such as those about noise, fuel consumption, and maintenance and is evidenced in individuals and through teamwork. This demonstration yields the reasonable expectation that any analysis of technology would have to include some understanding of human creativity.

9.2 Creativity not found in Theologies of technology

This expectation is disappointed because the analysis of human creativity does not feature in the various attempts to build a theology of technology explored in chapter 2. This failure means there is a tendency to understand technology as a thing or a force which has an 'existence of its own'⁷⁴² and removes it 'from its grounding within culture.'⁷⁴³ An understanding of how human technology fits into God's eschatological purposes is also frequently lacking. This raises the questions as to whether the creativity that is evidenced in the development of human technology is intended by God even though it is misused, and whether the products of that technology are simply for the

⁷⁴¹ Pattison, *Thinking About God in an Age of Technology*, 1.

⁷⁴² Florman, *The Existential Pleasures of Engineering*, 48.

⁷⁴³ DeLashMutt, 'Sketches Towards a Theology of Technology: Theological Confession in a Technological Age', 100.

world as we know it or whether they and human creativity itself will ultimately have some place within God's kingdom?

9.3 Creativity at the Heart of being human

To begin to answer these questions a broader look at creativity is undertaken which showed that it is not confined to those activities normally considered in some way to be artistic and it is not the preserve of a few gifted people who lead the way in human creative endeavours. Creative activities include, inter alia, all our scientific knowledge and understanding of the world. Creativity actually underlies everybody's tacit knowledge of the world for it is through our imaginative mental constructs that we gain our understanding of the world and also our ability to change it. The fact that imaginative creativity is fundamental to being human opens up the question as to how human creativity relates to the divine creativity which brought it into existence.

9.4 Human Creativity is a Reflection of God's Creativity

This relationship between divine and human creativity is then explored through the Biblical creation narratives in Genesis and the Christian belief in the Trinitarian God. A key focus of this exploration is the term 'image of God' used to describe human beings at their creation in the first chapter of Genesis. This yields an understanding of human beings as created purposefully by God with the capacity to have a special relationship with God and a creative role to play within the development of God's created order. The communal and creative nature of the Trinitarian God is imaged by human creativity which operates at a communal as well as an individual level. The disruption in the relationship of human beings with the created order as well as with God, caused by human rebellion against God as depicted in the Garden of Eden narrative, is then the background to ongoing human creativity with its positive and negative consequences.

9.5 The Dark Side is not fundamental to Creativity

Through an analysis of the negative consequences of human creativity it is observed that not only is there deliberate use of creativity to cause harm but also there are often unintended harmful consequences of creative activity. However the perspective of the person making a moral judgement is significant. These damaging outcomes result from the many other factors which affect the design, production, and use of novel creative products. These factors include the finitude of human knowledge, sin, will-to-power, and short-termism. The potential for external pressures to cause a major failure in a

technological project is explored through the examination of two major disasters, the R101 airship and the Challenger space shuttle. However it is demonstrated that the harmful effects of human creativity are not a direct consequence of the fundamental human ability to produce new ideas. This basic creative ability is properly interpreted theologically as a gift to humanity from God, an aspect of being created in the image of God. This still leaves the question open as to whether this gift is only to be exercised in the world as we currently know it with no eternal significance for the ultimate purposes of God's new creation.

9.6 Creativity, the City and God

To begin to answer this question of eternal significance a threefold examination of one product of human creative technology which has prominence in the Bible, i.e. the city, was undertaken. The history of the development of cities was explored followed by a look at a modern scientific attempt to understand them. This demonstrated the importance of cities to human beings and their desire for communal living. The Biblical narrative with its ambiguity about cities and their relationship to God was then examined. This ambiguity is resolved in the new heaven and the new earth, the product of God's new creation, where the appearance of the New Jerusalem is accompanied by the declaration, 'the home of God is among mortals', from God's throne. (Rev. 21.3) This reveals that the city, this complex development of intertwining technologies devised and developed by human beings, is not to be consigned to an eternal scrapheap but rather it is to be transformed. Thus it is indicated that as an outworking of human creativity, itself a gift from God, human technology and its products, transformed by the loving action of the creator God, have a place in God's eternal purposes.

9.7 Divine and Human Creativity

This affirmation sharpens up the difficulty of technology often being encountered as damaging and harmful. A historical survey demonstrates that this stems from modern technology being undergirded by a misunderstanding of what it means for human beings to be created in the image of God. A further study of the biblical writings shows that violence and coercion are not fundamentally part of God's being or creation. Ultimately it is the non-violence and humility of God shown in the incarnation of Jesus Christ and the redemption brought about through him that is to be imaged by human beings in all

their activities including technology. The question of how technology fits in to the fullness of God's purposes is still left open at this point.

9.8 The Purposes of God

God's purpose is not to be achieved by God dictating all that will happen from the outset of creation. Rather God brings into being a bounded creative space in which God's creation, including human beings, can play a significant part in God's creative activity. Human beings themselves are not the ultimate goal of that activity but they do have an important part to play. The granting of this real freedom entails risk for God in that what transpires may not be in accordance with God's nature and purpose. So it is that there will be a 'New Creation' in which the original creation, including its human technological contribution, will be transformed in love by divine decisive action in establishing God's kingdom. This is prefigured and affirmed by God through the historical bodily resurrection of Jesus Christ. How people live in this world is to be seen as an important preparation for what is to come which, given the creative nature of God, will not be a static existence but one in which there is a transformed creative space for ongoing creativity undertaken in part by transformed human beings. In that space there may yet be found a place for aviation technology to play its part in the eternal praise of The Divine Creator.

9.9 In Summary

What has been uncovered is that technology is a result of the interaction of the imaginative creativity of human beings with the environment in which they are set. This creative ability is God's gift to them resulting from their being created in God's image and thereby invited to play a part in the development of God's creation in its present form and in the eschatological new creation. Contrary to what often has been evidenced so far in the history of modern technology this gift is to be used in a manner that accords with the nature of God which is supremely revealed through the incarnation, death, and resurrection of Jesus Christ. These events demonstrate the love and humility of God and seal God's commitment to the whole created order including human beings and the significant role they are called on to play through the exercise of their creativity.

APPENDIX

Illustrations relating to Creativity in Aviation in Chapter 1



Boeing 737



Boeing 757



Boeing 767



Boeing 777



Airbus A320



Airbus A330

Fig.1.1 Examples of Modern 'Tube and Wing' airliners (Author's own photographs)



BAe 146



Embraer 145

Fig.1.2 Variations on 'Tube and Wing' Design (Author's own photographs)

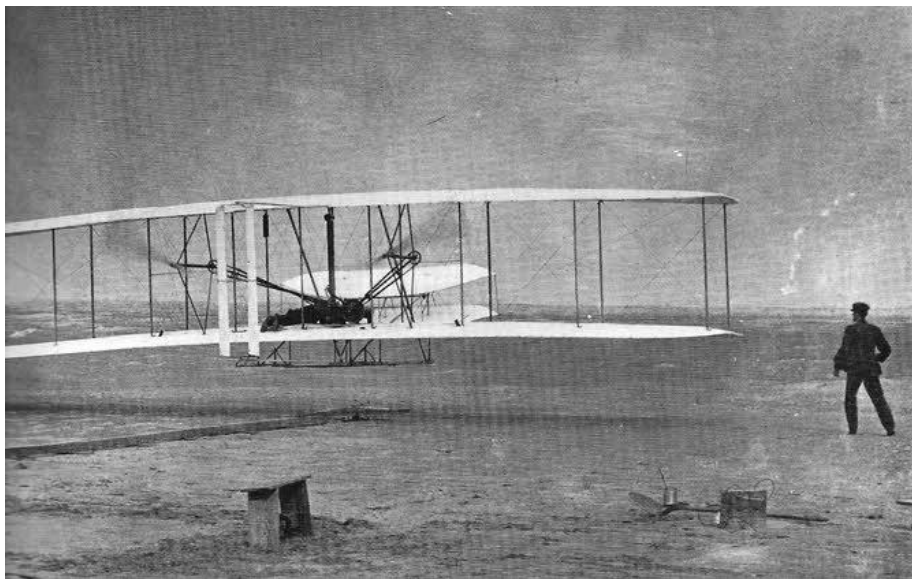

Fig.1.3 First Flight with Orville at the controls and Wilbur standing to the right
From Orville Wright 'How We Invented the Airplane', p.43

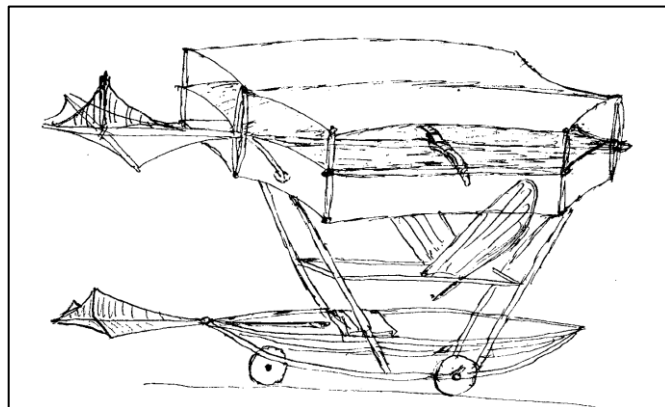

Fig.1.4 George Cayley's 1853 sketch of the 1849 child-carrying craft
From C. H. Gibbs-Smith 'Sir George Cayley's Aeronautics 1796-1855', p.128

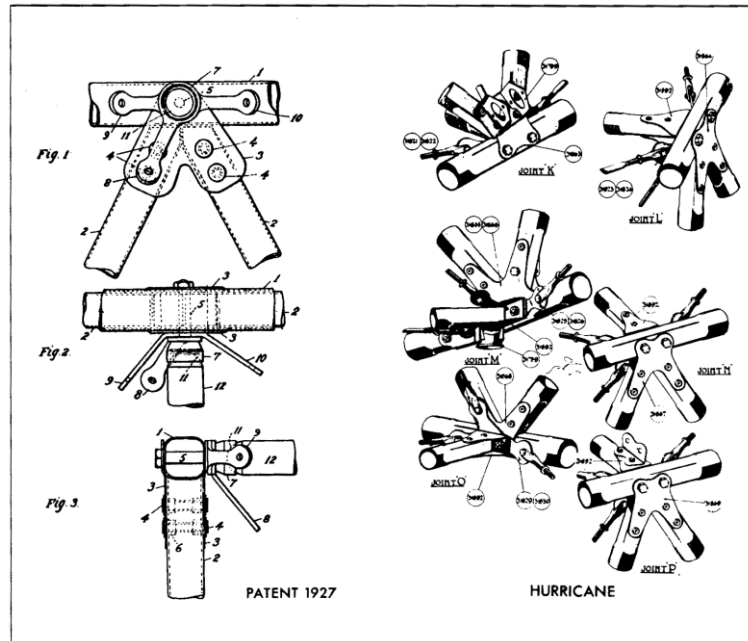

Fig.1.5 Comparison of Camm's 1927 patent joints with Hurricane fuselage joints
From Robert L. Lickley 'The Life and Work of Sir Sydney', p.59



Fig.1.6 Burt Rutan's prototype Variviggen
From <http://www.museumofflight.org/aircraft/rutan-model-27-variviggen>



Fig.1.7 The Virgin Galactic vehicle and launcher
From http://en.wikipedia.org/wiki/File:SS2_and_VMS_Eve.jpg



Fig.1.8 Rutan's Beech Starship
From http://www.scaled.com/hires_gallery/gallery/starship/

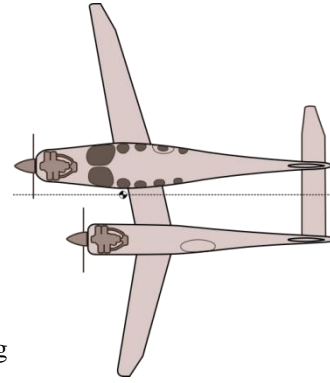

Fig.1.9 Photograph and plan view of the Rutan Boomerang
From <http://www.rutanboomerang.com/>

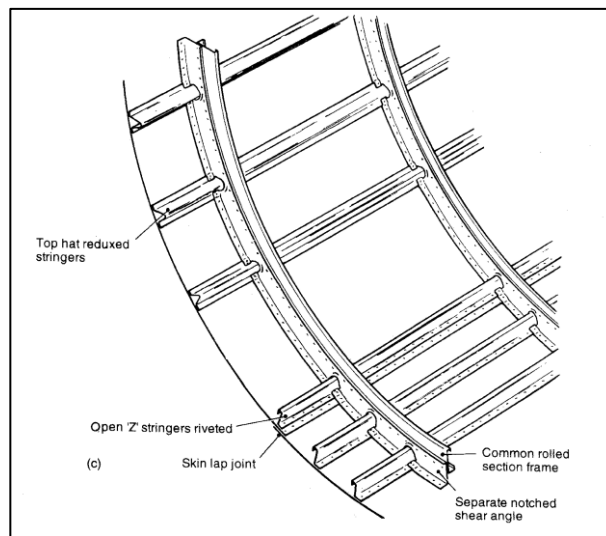

Fig.1.10 Diagram of riveted and glued skin panel
From Cutler & Liber 'Understanding Aircraft Structures' 4th ed. p.137



Fig.1.11 Examples of a wing rib (left) and wing skin (right) milled from solid aluminium alloy
From Whitford 'Structure and Materials' p.76f



Fig.1.12 All-carbonfibre reinforced plastic fin box of Airbus A310
From Whitford 'Structure and Materials' p.79

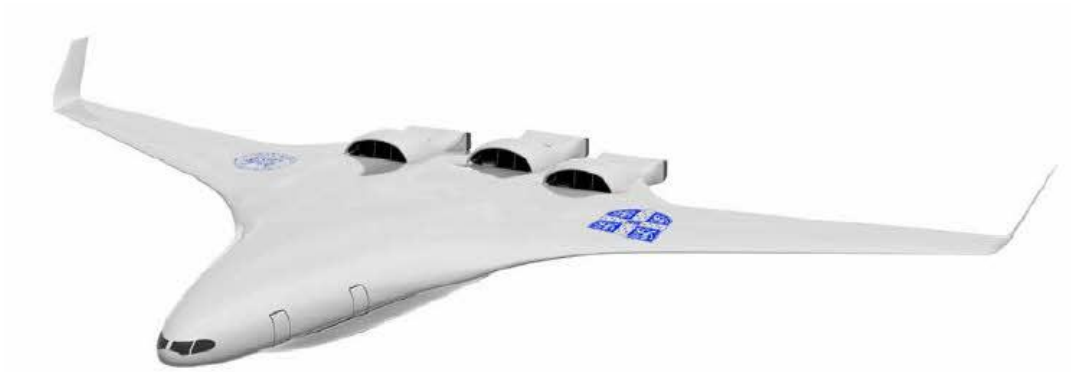

Fig.1.13 The Silent Aircraft Initiative SAX-40 (From <http://silentaircraft.org/sax40>)

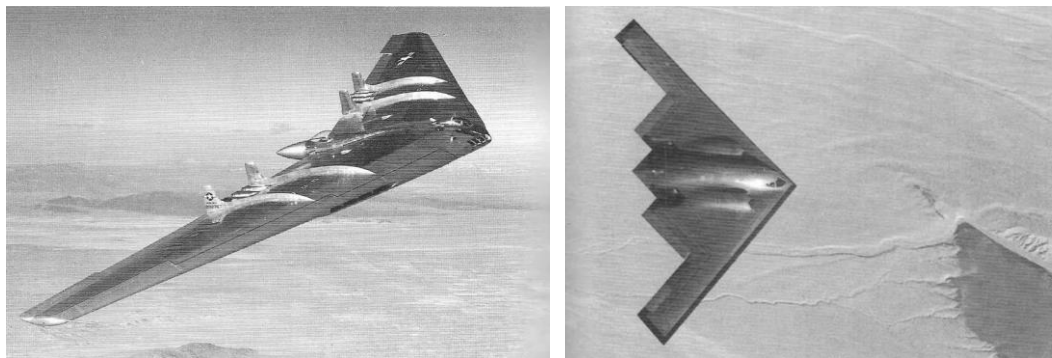

Fig.1.14 Northrop's Flying Wings, the YB-49 Experimental Bomber and the B-2 Stealth Bomber
(From Robert Jackson. 'Offensive Aircraft in a New Age')



Fig.1.15 X-48C Blended Wing Body Test Model Aircraft
 (From www.boeing.com/Features/2013/04/bds_x48c_04_24_13.html)

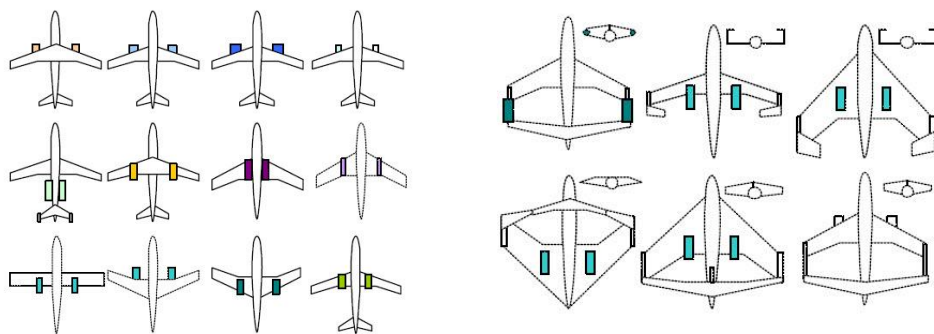

Fig.1.16 Extreme options from brain-storming sessions. Conventional (left) and Innovative (right)
 From Fielding et al 'Development of Silent Airframe Concepts' p.7f

<i>Attribute</i>	<i>Weighting (w)</i>
<i>Far-field Airframe Noise</i>	10
<i>Far-field Engine Noise</i>	10
<i>Environmental Effects</i>	9
<i>Cost (development, DOC, etc)</i>	8
<i>Minimum weight</i>	8
<i>Certification</i>	8
<i>Reliability and Maintainability</i>	8
<i>Familiarity / Risks</i>	8
<i>Passenger comfort / environment</i>	7
<i>Crashworthiness / Emergency egress</i>	6
<i>Airport Infrastructure</i>	6
<i>Passenger local internal noise</i>	5
Maximum possible Aircraft Score (w×10)	930

Fig.1.17 Weighting table used to evaluate options
 From Mistry 'A Novel Airframe Design Methodology for Silent Aircraft' p.25

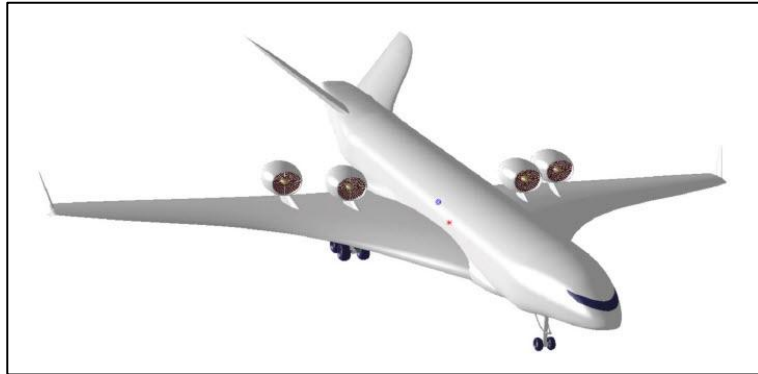

Fig.1.18 Interim silent aircraft design proposal
From Mistry 'A Novel Airframe Design Methodology for Silent Aircraft' p.129



Fig.1.19 Cranfield's 'Greenliner' design proposal
From Mistry et al 'Novel Design Concepts for Aircraft with reduced
Noise and Global Warming Characteristics.' P.4

Bibliography

- A350 Xwb Technology. In, Airbus,
<http://www.airbus.com/aircraftfamilies/passengeraircraft/a350xwbfamily/technology-and-innovation/>. (accessed 23rd August, 2013).
- Aldridge, Maurice V. *The Elements of Mathematical Semantics*. New York: Mouton de Gruyter, 1992.
- Alexander, William, and Arthur Street. *Metals in the Service of Man*. 9th ed. London: Penguin, 1989.
- Andrews, C. F., and E. B. Morgan. *Supermarine Aircraft since 1914*. London: Putnam, 1981.
———. *Vickers Aircraft since 1908*. 2nd ed. London: Putnam, 1988.
- Anthony, David W. *The Horse the Wheel and Language*. Princeton, New Jersey: Princeton University Press, 2007.
- Barbour, Ian G. *Religion in an Age of Science*. 1st ed. New York: HarperCollins, 1990.
———. *When Science Meets Religion*. 1st ed. London: SPCK, 2000.
- Barbour, R. S., 'Creation, Wisdom and Christ.' in Richard W.A. McKinney (ed.), *Creation Christ and Culture*. (Edinburgh: T. & T. Clark, 1976). 22-42.
- Barrow, John D. *Cosmic Imagery*. London: The Bodley Head, 2008.
- Batto, Bernard F., 'Creation Theology in Genesis.' in Richard J. Clifford and John J. Collins (eds.), *Creation in the Biblical Traditions*. (Washington, DC: Catholic Biblical Association of America, 1992).
———. *Slaying the Dragon: Mythmaking in the Biblical Tradition*. Louisville, Ky.: Westminster/John Knox Press, 1992.
- Bauckham, Richard. *The Theology of the Book of Revelation*. Kindle ed. Cambridge: Cambridge University Press, 1993.
- Bauckham, Richard, and Trevor Hart. *Hope against Hope*. London: Darton, Longman & Todd, 1999.
- Beghetto, Ronald A., and Jonathan A. Plucker. 'The Relationship among Schooling, Learning, and Creativity: "All Roads Lead to Creativity" or "You Can't Get There from Here".' in James C. Kaufman and John Baer (eds.), *Creativity and Reason in Cognitive Development*. (New York: Cambridge University Press, 2006). 316-32.
- Bell, Trudy E., and Karl Esch. 'The Fatal Flaw in Flight 51-L.' *Spectrum, IEEE* 24, no. 2 (1987): 36-51.
- Benedict XVI, Pope. 2006. Faith, Reason and the University: Memories and Reflections. In, http://www.vatican.va/holy_father/benedict_xvi/speeches/2006/september/document_s/hf_ben-xvi_spe_20060912_university-regensburg_en.html. (accessed 27th June 2007).
- Berkouwer, G. C. *Man: The Image of God, Studies in Dogmatics*. Grand Rapids: Eerdmans, 1972.
- Bernal, J. D. *Science in History*. 2nd ed. London: Watts, 1957.
- Bettencourt, Luis M. A., and Geoffrey West. 'Bigger Cities Do More with Less.' *Scientific American*, September 2011, 52-53.
- Bird, Phyllis A. "'Male and Female He Created Them": Gen 1:27b in the Context of the Priestly Account of Creation.' *The Harvard Theological Review* 74, no. 2 (1981): 129-59.
- Blair, George A., 'Faith Outside Technique.' in Carl Mitcham and Jim Grote (eds.), *Theology and Technology*. (Lanham: University Press of America, 1984). 45-52.
- Boden, Margaret. 'Artificial Intelligence and the Far Future.' in George F. R. Ellis (ed.), *The Far Future Universe*. (Radnor: Templeton Foundation Press, 2002). 207-24.
- Boden, Margaret A., 'Computer Models of Creativity.' in Robert J. Sternberg (ed.), *Handbook of Creativity*. (Cambridge: Cambridge University Press, 1999). 351-72.
———. *The Creative Mind*. 2nd ed. London: Routledge, 2004.
———. 'Precis of the Creative Mind: Myths and Mechanisms.' *Behavioral and Brain Sciences* 17, no. 3 (1994): 519-31.

- Bohm, David. 'On Creativity.' in Lee Nichol (ed.), *On Creativity*, 1st ed. (London: Routledge, 1998), Reprint, 2004.
- Boisjoly, Roger. 1987. Pre-Disaster Background (Ethical Decisions - Morton Thiokol and the Challenger Disaster). In, National Academy of Engineering, http://www.onlineethics.org/Topics/ProfPractice/PPEssays/thiokolshuttle/shuttle_pre.a.spx. (accessed March 26th, 2013).
- . 1987. Telecon Meeting (Ethical Decisions - Morton Thiokol and the Challenger Disaster) In, National Academy of Engineering, http://www.onlineethics.org/Topics/ProfPractice/PPEssays/thiokolshuttle/shuttle_telecon.aspx. (accessed March 26th, 2013).
- Bolan, Marc. T. Rex Lyrics - Get It On. In, <http://www.azlyrics.com/lyrics/trex/getiton.html>. (accessed 24th June, 2014).
- Borgmann, Albert. *Power Failure*. Grand Rapids: Brazos Press, 2003.
- Bowler, Tim. 2014. Carbon Fibre Planes: Lighter and Stronger by Design. In, <http://www.bbc.co.uk/news/business-25833264>. (accessed 28th January, 2014).
- Brechner, Larry A. Eaa Air Venture Museum Exhibit. In, <http://www.brech.com/np/aviation/EAA.html>. (accessed 23th May, 2014).
- Brett, Mark G., 'Earthing the Human in Genesis 1-3.' in Norman C. Habel and Shirley Wurst (eds.), *The Earth Story in Genesis*. (Sheffield: Sheffield Academic Press, 2000). 73-86.
- Bronowski, J. *The Ascent of Man*. London: Book Club Associates, 1973.
- Brooke, John H. *Science and Religion. Some Historical Perspectives*. 1st ed. Cambridge: Cambridge University Press, 1991.
- Brown, David. *Discipleship and Imagination*. Oxford: Oxford University Press, 2000.
- . *Tradition and Imagination*. Oxford: Oxford University Press, 1999.
- Brueggemann, Walter. *Genesis*. Edited by James Luther Mays, Patrick D. Miller and Paul J. Achtemeier, *Interpretation: A Bible Commentary for Teaching and Preaching*. Atlanta: John Knox Press, 1982.
- . 'A Shape for Old Testament Theology, 2: Embrace of Pain.' in Patrick D. Miller (ed.), *Old Testament Theology: Essays on Structure, Theme, and Text*. (Minneapolis: Fortress Press, 1992).
- Bryant, David J. *Faith and the Play of Imagination*. Edited by Charles Mabee, *Studies in American Biblical Hermeneutics*. Macon: Mercer University Press, 1989.
- Bryant, Linwood. 'The Beginnings of the Internal-Combustion Engine.' in Melvin Kranzberg and Carroll W. Pursell (eds.), *Technology in Western Civilization*. (New York: Oxford University Press, 1967).
- Bushell, Sue. 'Business Aviation.' in Philip Jarrett (ed.), *Modern Air Transport*. (London: Putnam, 2000). 229 - 42.
- Butterfield, Herbert. *The Origins of Modern Science*. 2nd ed. London: G. Bell and Sons, 1957.
- Cajori, Florian. *A History of Mathematical Notations*. Vol. 1. Chicago: Open Court Publishing Company, 1928.
- Cardwell, Donald. *The Norton History of Technology*. Edited by Roy Porter, *Norton History of Science*. New York: W.W.Norton & Company, 1994.
- Carr, David M. *Reading the Fractures of Genesis*. Louisville, Kentucky: Westminster/John Knox Press, 1996.
- Case-Winters, Anna. 'Rethinking Divine Presence and Activity in World Process.' in Thomas Jay Oord (ed.), *Creation Made Free*, Kindle ed. (Eugene, Oregon: Wipf and Stock, 2009). Loc. 1657-6824.
- . 'Rethinking the Image of God.' *Zygon* 39, no. 4 (2004): 813-26.
- Cassuto, U. *A Commentary on the Book of Genesis*. Jerusalem: Magnes Press, 1978.
- Chanute, Octave. *Progress in Flying Machines*. Dover 1997 ed. New York: American Engineer and Railroad Journal, 1894.

- Cheek, Dennis William. 'Theology & Technology: An Exploration of Their Relationship with Special Reference to the Work of Albert Borgmann and Intelligent Transportation Systems.' PhD, Durham, 2006.
- Childs, Brevard S. *Biblical Theology of the Old and New Testaments*. Kindle ed. Minneapolis: Fortress Press, 1992.
- Chorost, Michael. *Rebuilt. How Becoming Part Computer Made Me More Human*. London: Souvenir Press, 2006.
- Christie, Frances. 'Science and Apprenticeship.' in J. R. Martin and Robert Veal (eds.), *Reading Science: Critical and Functional Perspectives on Discourses of Science*. (London: Routledge, 1998). 153-75.
- Clark, D. 2001. 211 Squadron Raf. In, D Clark & others, http://www.211squadron.org/w_baird.html. (accessed 23rd August, 2013).
- Clarke, Arthur C., 'The Nine Billion Names of God.' *The Collected Stories*. (London: Gollanz, 2000). 417-22.
- Clines, David J. A., 'Humanity as the Image of God.' in David J. A. Clines and Philip R. Davies (eds.), *On the Way to the Postmodern*. (Sheffield: Sheffield Academic Press, 1998). 447-97.
- . 'Philology and Power.' in David J. A. Clines and Philip R. Davies (eds.), *On the Way to the Postmodern*. (Sheffield: Sheffield Academic Press, 1998). 613-30.
- Cohen, Gillian. 'Overview: Conclusions and Speculations.' in Gillian Cohen and Martin A. Conway (eds.), *Memory in the Real World*. (Hove, East Sussex: Psychology Press, 2008). 381-90.
- . 'The Study of Everyday Memory.' in Gillian Cohen and Martin A. Conway (eds.), *Memory in the Real World*. (Hove, East Sussex: Psychology Press, 2008). 1-20.
- Cole-Turner, Ronald. 'Science, Technology, and Mission.' in Max L. Stackhouse, Tim Dearborn and Scott Paeth (eds.), *The Local Church in a Global Era*. (Grand Rapids: William B. Eerdmans, 2000). 100 - 12.
- Coulson, C.A. *Faith and Technology*. London: Chester House Publications, 1969. Reprint, 1974.
- . *Science, Technology & the Christian*. London: Epworth Press, 1960. Reprint, 1961.
- Cropley, Arthur J. 'Creativity in the Classroom.' in David H Cropley, Arthur J Cropley, James C Kaufman and Mark A Runco (eds.), *The Dark Side of Creativity*. (New York: Cambridge University Press, 2010). 297-315.
- . 'The Dark Side of Creativity.' in David H Cropley, Arthur J Cropley, James C Kaufman and Mark A Runco (eds.), *The Dark Side of Creativity*, 1st ed. (New York: Cambridge University Press, 2010). 1-14.
- Cropley, David H. 'Malevolent Innovation.' in David H Cropley, Arthur J Cropley, James C Kaufman and Mark A Runco (eds.), *The Dark Side of Creativity*. (New York: Cambridge University Press, 2010).
- Cropley, David H, James C Kaufman, and Arthur J Cropley. 'Malevolent Creativity: A Functional Model of Creativity in Terrorism and Crime.' *Creativity Research Journal* 20, no. 2 (2008): 105-15.
- Csikszentmihalyi, Mihaly. *Creativity*. New York: HarperCollins, 1997.
- Cutler, John, and Jeremy Liber. *Understanding Aircraft Structures*. 4th ed. Oxford: Blackwell, 2005.
- Davies, Paul C. W. *The Cosmic Blueprint*. London: Heinemann, 1987.
- Dawkins, Richard. *Climbing Mount Improbable*. London: Penguin, 1997.
- DeLashMutt, Michael W. 'Sketches Towards a Theology of Technology: Theological Confession in a Technological Age.' PhD, Glasgow, 2006.
- Derry, T. K., and Trevor I. Williams. *A Short History of Technology*. 1st ed. London: Oxford University Press, 1970.
- Designed with the Future in Mind. In, Airbus, <http://www.a350xwb.com/intelligent/design/>. (accessed 23rd August, 2013).

- Doulgeris, Georgios C. 'Modelling & Integration of Advanced Propulsion Systems.' Cranfield, 2008.
- Dowling, Ann, and Ed Greitzer. 'The Silent Aircraft Initiative – Overview.' In *45th AIAA Aerospace Sciences Meeting*. Reno, 2007.
- Drachmann, A. G., 'The Classical Civilizations.' in Melvin Kranzberg and Carroll W. Pursell (eds.), *Technology in Western Civilization*. (New York: Oxford University Press, 1967).
- Drees, Willem B., 'Introduction: Technological and Moral Creatures or Creators?', in Ulf Gorman, Willem B. Drees and Hubert Meisinger (eds.), *Creative Creatures*. (London: T&T Clark, 2005). 1-12.
- . *Religion, Science and Naturalism*. 1st ed. Cambridge: Cambridge University Press, 1996.
- Dreyfus, Hubert. 'Heidegger on Gaining a Free Relation to Technology.' in David M Kaplan (ed.), *Readings in the Philosophy of Technology*. (Lanham: Rowman and Littlefield, 2004). 53-62.
- Driver, S. R. *The Book of Genesis*. Edited by Walter Lock. 5th ed, *Westminster Commentaries*. London: Methuen, 1906.
- Dyson, Freeman J., 'Life in the Universe: Is Life Digital or Analogue.' in George F. R. Ellis (ed.), *The Far-Future Universe*. (Radnor: Templeton Foundation Press, 2002). 140-57.
- Eichrodt, Walter. *Theology of the Old Testament*. Vol. 2. London: SCM Press, 1967.
- Ellis, George F. R., 'Natures of Existence.' in George F. R. Ellis (ed.), *The Far-Future Universe*. (Radnor: Templeton Foundation Press, 2002). 316-54.
- Ellul, Jacques. *The Meaning of the City*. Grand Rapids: William B. Eerdmans, 1973.
- . 'Nature, Technique and Artificiality.' in Paul T. Durbin (ed.), *Research in Philosophy and Technology*, 1st ed. (Greenwich, Connecticut: JAI Press, 1980). 263 - 83.
- . 'The Relationship between Man and Creation in the Bible.' in Carl Mitcham and Jim Grote (eds.), *Theology and Technology*: University Press of America, 1984). 139-55.
- . 'Technique and the Opening Chapters of Genesis.' in Carl Mitcham and Jim Grote (eds.), *Theology and Technology*: University Press of America, 1984). 123-37.
- . 'The Technological Order.' in Carl Mitcham and Robert Mackay (eds.), *Philosophy and Technology*, 1st ed. (New York: The Free Press, 1983). 86 - 105.
- . *The Technological Society*. Translated by John Wilkinson. New York: Vintage Books, 1964.
- Ernest Rutherford. In, http://en.wikiquote.org/wiki/Ernest_Rutherford. (accessed 27th March, 2014).
- Essinger, James. *Jacquard's Web*. Oxford: Oxford University Press, 2004.
- Feist, G. J., 'Influence of Personality on Artistic and Scientific Creativity.' in Robert J. Sternberg (ed.), *Handbook of Creativity*. (Cambridge: Cambridge University Press, 1999). 273-96.
- Fensham, F.C., 'Paradise.' in J.D. Douglas (ed.), *The Illustrated Bible Dictionary (Part 3)*. (Leicester: Inter-varsity Press, 1980). 1155.
- Feynman, Richard P., 'Cargo Cult Science.' in Jeffrey Robbins (ed.), *The Pleasure of Finding Things Out*. (London: Penguin Books, 2001). 205-16.
- . 'The Pleasure of Finding Things Out.' in Jeffrey Robbins (ed.), *The Pleasure of Finding Things Out*. (London: Penguin Books, 2001). 2-25.
- . 'Richard P. Feynman's Minority Report to the Space Shuttle Challenger Inquiry.' in Jeffrey Robbins (ed.), *The Pleasure of Finding Things Out*. (London: Penguin Books, 2001). 152-69.
- Fielding, John P. *Introduction to Aircraft Design*. Edited by Michael J. Rycroft and Robert F. Stengel, *Cambridge Aerospace Series*. Cambridge: Cambridge University Press, 1999.
- Fielding, John P., P. Pilidis, Sunil Mistry, and Georgios C. Doulgeris. 'Development of Silent Airframe Concepts and Innovative Cycle Propulsion Systems for Reduction in Aircraft Noise.' In *25th International Congress of the Aeronautical Sciences*. Hamburg, 2006.

- Findlay, Alexander, and Trevor I. Williams. *A Hundred Years of Chemistry*. 3rd revised ed. London: Duckworth, 1965.
- Fisk, Fred C., and Marlin W. Todd. *The Wright Brothers from Bicycle to Biplane*. Ohio: Fred C. Fisk & Marlin W. Todd, 2003.
- Florman, Samuel C. *The Existential Pleasures of Engineering*. New York: St. Martin's Press, 1976.
- Forbes, R. J., 'Mesopotamian and Egyptian Technology.' in Melvin Kranzberg and Carroll W. Pursell (eds.), *Technology in Western Civilization*. (New York: Oxford University Press, 1967).
- Frank, Adam. *About Time*. Oxford: Oneworld Publications, 2012.
- Fretheim, Terence E. *God and World in the Old Testament*. Nashville: Abingdon Press, 2005.
- Fudpucker, Wilhelm E., 'Through Technological Christianity to Christian Technology.' in Carl Mitcham and Jim Grote (eds.), *Theology and Technology*: University Press of America, 1984). 53-69.
- Fund, RAF Benevolent. The Heart Roundel. In, <http://www.rafbf.org/files/vapour-trail-red-arrows-heart-maneuvre-604.jpg>. (accessed 23rd May, 2014).
- Fuqua (Chair), Don. 'Investigation of the Challenger Accident.' edited by Committee on Science and Technology of the House of Representatives. Washington: U.S. Government Printing Office, 1986.
- Gamman, Lorraine, and Maziar Raein. 'Reviewing the Art of Crime.' in David H Cropley, Arthur J Cropley, James C Kaufman and Mark A Runco (eds.), *The Dark Side of Creativity*. (New York: Cambridge University Press, 2010).
- Garner, Stephen. 'Hacking the Divine.' *Colloquium* 37, no. 2 (2005): 181-95.
- George, A. R. *The Babylonian Gilgamesh Epic*. Vol. 1. Oxford: Oxford University Press, 2003.
- Gibbs-Smith, Charles H. *Sir George Cayley's Aeronautics*. London: Her Majesty's Stationery Office, 1962.
- Goddard, Andrew. *Living the Word, Resisting the World*. 1st ed. Carlisle: Paternoster Press, 2002.
- Goodall, Howard. *Big Bangs: The Story of Five Discoveries That Changed Musical History*. London: Vintage, 2001.
- Goold, Ian. 'The Modern Jet Airliner - the Trailblazers.' in Philip Jarrett (ed.), *Modern Air Transport*. (London: Putnam, 2000). 155-86.
- Gorringe, Timothy. 'Salvation by Bricks: Theological Reflections on the Planning Process.' *International Journal of Public Theology* 2 (2008): 98-118.
- Government, UK. 1993. Clean Air Act 1993. In, <http://www.legislation.gov.uk/ukpga/1993/11/contents>. (accessed 15th March, 2013).
- Griffiths, Brian. *Engineering Drawing for Manufacture*. London: Kogan Page Science, 2006.
- Gunton, Colin E. *Christ and Creation*. Eugene, Oregon: Wipf and Stock, 2005.
- . 'Introduction.' in Colin E Gunton (ed.), *The Doctrine of Creation*. (London: T. & T. Clark, 2004). 1-15.
- Habel, Norman C., 'Geophany.' in Norman C. Habel and Shirley Wurst (eds.), *The Earth Story in Genesis*. (Sheffield: Sheffield Academic Press, 2000). 34-48.
- Habermas, Jürgen. 'Technical Progress and the Social Life-World.' in David M Kaplan (ed.), *Readings in the Philosophy of Technology*, 1st ed. (Lanham: Rowman and Littlefield, 2004). 81-87.
- Hall, Douglas John. 'Toward an Indigenous Theology of the Cross.' in Carl Mitcham and Jim Grote (eds.), *Theology and Technology*: University Press of America, 1984). 247-69.
- Hallion, Richard P. *Taking Flight*. New York: Oxford University Press, 2003.
- Hanson, Thomas F. *Engineering Creativity*. 2nd ed. Newhall, CA: T. F. Hanson, 1987. Reprint, 1997.
- Haraway, Donna J., 'A Cyborg Manifesto.' in David M Kaplan (ed.), *Readings in the Philosophy of Technology*. (Lanham: Rowman & Littlefield, 2004). 161-77.

- Harrison, R. K. *Biblical Hebrew, Teach Yourself Books*. London: Hodder and Stoughton, 1979.
- Hauerwas, Stanley. *With the Grain of the Universe*. London: SCM Press, 2002.
- Hauerwas, Stanley, and William H. Willimon. *Resident Aliens*. Nashville: Abingdon Press, 1989.
- Hawkin, David J., and Eileen Hawkin. *The Word of Science*. London: Epworth Press, 1989.
- Hecht, David K., 'Imagining the Bomb.' in David H Cropley, Arthur J Cropley, James C Kaufman and Mark A Runco (eds.), *The Dark Side of Creativity*. (New York: Cambridge University Press, 2010).
- Hedley, Douglas. *Living Forms of the Imagination*. London: T & T Clark, 2008.
- Hefner, Philip. 'The Evolution of the Created Co-Creator.' in Ted Peters (ed.), *Cosmos as Creation*, 1st ed. (Nashville: Abingdon, 1989). 211-33.
- . *The Human Factor*. Minneapolis: Fortress Press, 1993.
- . *Technology and Human Becoming*. Minneapolis: Fortress Press, 2003.
- Heidegger, Martin. 'The Question Concerning Technology.' *The Question Concerning Technology and Other Essays*. (New York: Harper & Row, 1977). 3-35.
- Hooke, S. H., 'Genesis.' in Matthew Black and H. H. Rowley (eds.), *Peake's Commentary on the Bible*. (London: Thomas Nelson and Sons, 1962).
- Hooykaas, R. *Religion and the Rise of Modern Science*. Edinburgh: Scottish Academic Press, 1973.
- Hopper, David H. *Technology, Theology, and the Idea of Progress*. Louisville, Kentucky: Westminster/John Knox Press, 1991.
- Horne, Jim. 'To Sleep, Perchance to Think.' *Daily Telegraph*, May 2nd 2006.
- Hovestadt, Ludger. 2012. The Surprising Success of Fundamental Proportionalism. In, Vimeo, LLC, <http://vimeo.com/44548590>. (accessed January 28th, 2013).
- Hughes, Thomas P. *American Genesis*. 2nd ed. Chicago: University of Chicago Press, 2004.
- Hulings, Nate. 2013. X-48c Research Aircraft Wraps up Flight Tests. In, Boeing, http://www.boeing.com/Features/2013/04/bds_x48c_04_24_13.html. (accessed 26th July, 2013).
- Irenaeus. *Five Books of S. Irenaeus against Heresies*. Translated by John Keble, *Library of Fathers of the Holy Catholic Church*. Oxford: James Parker, 1872.
- Jackson, Robert. 'Offensive Aircraft in a New Age.' in Philip Jarrett (ed.), *The Modern War Machine*. (London: Putnam, 2000).
- Jaki, Stanley L., 'Theological Aspects of Creative Science.' in Richard W.A. McKinney (ed.), *Creation Christ and Culture*. (Edinburgh: T. & T. Clark Ltd, 1976). 149-66.
- James, Keith, and Aisha Taylor. 'Positive Creativity and Negative Creativity (and Unintended Consequences).' in David H Cropley, Arthur J Cropley, James C Kaufman and Mark A Runco (eds.), *The Dark Side of Creativity*. (New York: Cambridge University Press, 2010). 33-56.
- Jastrow, Morris, and Albert T. Clay. *An Old Babylonian Version of the Gilgamesh Epic*. New Haven: Yale University Press, 1920.
- Jenson, Robert W., 'Aspects of a Doctrine of Creation.' in Colin E Gunton (ed.), *The Doctrine of Creation*. (London: T&T Clark, 2004). 17-28.
- . *Systematic Theology*. 2 vols. Vol. 1. New York: Oxford University Press, 2001.
- . *Systematic Theology*. 2 vols. Vol. 2. New York: Oxford University Press, 2001.
- Jonas, Hans. 'Towards a Philosophy of Technology.' in David M Kaplan (ed.), *Readings in the Philosophy of Technology*, 1st ed. (Lanham: Rowman & Littlefield, 2004). 17 - 33.
- Jones, Steve. 'View from the Lab.' *Daily Telegraph*, 21st October 2008.
- Kahneman, Daniel. *Thinking, Fast and Slow*. London: Penguin, 2011.
- Kaplan, David M, ed. *Readings in the Philosophy of Technology*. Lanham, Maryland: Rowman & Littlefield, 2004.
- Kasman, Alex. 'Unreasonable Effectiveness.' *Reality Conditions*. (Washington, DC.: The Mathematical Association of America, 2005). 1-6.

- Kidner, Derek. *Genesis: An Introduction and Commentary*. Edited by D. J. Wiseman, *The Tyndale Old Testament Commentaries*. London: Tyndale Press, 1967.
- Klein, Ursula. *Experiments, Models, Paper Tools: Cultures of Organic Chemistry in the Nineteenth Century, Writing Science*. Stanford: Stanford University Press, 2003.
- , ed. *Tools and Modes of Representation in the Laboratory Sciences*. Vol. 222, *Boston Studies in the Philosophy of Science*. Dordrecht: Kluwer Academic Publishers, 2001.
- Kleinman, Zoe. 2013. How Are Aeroplanes Getting Quieter? In, <http://www.bbc.co.uk/news/technology-23260462>. (accessed 19th September, 2013).
- Kline, Meredith G., 'Genesis.' in D. Guthrie and J. A. Motyer (eds.), *The New Bible Commentary Revised*, 3rd ed. (London: Inter-Varsity Press, 1970).
- Knell, D. M., and D. Lunn. 'Report 119: Effect of Asymmetry of Aerodynamic Nozzles Operating in near-Critical Conditions.' Bristol: Dept of Aeronautical Engineering, University of Bristol, 1969.
- Koestler, Arthur. *The Act of Creation*. Picador ed. London: Pan Books, 1975.
- Kuhn, Thomas S. *The Structure of Scientific Revolutions*. 3rd ed. Chicago: University of Chicago, 1996.
- Ladner, Gerhart B. *The Idea of Reform*. Cambridge, Mass.: Harvard University Press, 1959.
- Landes, George M., 'Creation Tradition in Proverbs 8:22-31 and Genesis 1.' in Howard N. Bream, Ralph Daniel Heim and Carey A. Moore (eds.), *A Light Unto My Path*. (Philadelphia: Temple University Press, 1974).
- Large Hadron Collider. In, Science and Technology Facilities Council, <http://www.stfc.ac.uk/646.aspx>. (accessed 20th February, 2014).
- Larson, Kent. 2012. Brilliant Designs to Fit More People in Every City. In, TED, http://www.ted.com/talks/kent_larson_brilliant_designs_to_fit_more_people_in_every_city.html. (accessed January 28th, 2013).
- Lash, Nicholas. 'What Might Martyrdom Mean?', *Theology on the Way to Emmaus*. (London: SCM Press, 1986). 75-92.
- Legge, Marilyn J. 'Colourful Differences: 'Otherness' and the Image of God for Canadian Feminist Theologies.' *Studies in Religion. Sciences Religieuses* 21 (1992).
- Lehrer, Johan. 'A Physicist Solves the City.' *The New York Times*, December 17th 2010.
- Leupold, H. C. *Exposition of Genesis*. London: Evangelical Press, 1972.
- Lichtheim, Miriam. *Ancient Egyptian Literature: A Book of Readings*. Vol. 1. Berkeley: University of California Press, 1973.
- Lickley, Robert L., 'The Life and Work of Sir Sydney.' in John W. Fozard (ed.), *Sydney Camm and the Hurricane*. (Shrewsbury: Airlife Publishing, 1991).
- Linthicum, Robert C. *City of God, City of Satan*. 1st ed. Grand Rapids: Zondervan, 1991.
- Lonergan, Bernard J. F. *Insight: A Study of Human Understanding*. 2nd rev. ed. London, New York: Longmans, Green, 1958.
- Lunn, David. '100 Years of Sustained Powered Flight.' *Borderlands/St John's College, Durham*, no. 3 (2004): 39f.
- Mabee, Charles. 'Biblical Hermeneutics and the Critique of Technology.' in Carl Mitcham and Jim Grote (eds.), *Theology and Technology*: University Press of America, 1984). 157-69.
- Malet, André. 'The Believer in the Presence of Technique.' in Carl Mitcham and Jim Grote (eds.), *Theology and Technology*: University Press of America, 1984). 91-106.
- Marcuse, Herbert. 'Social Implications of Technology.' in David M Kaplan (ed.), *Readings in the Philosophy of Technology*. (Lanham: Rowman & Littlefield, 2004). 63 -79.
- Mason, Francis K. *Hawker Aircraft since 1920*. London: Putnam, 1991.
- . *The Hawker Hurricane*. Manchester: Crécy Publishing, 2001.
- Maugh II, Thomas H. 'Photochemical Smog: Is It Safe to Treat the Air?' *Science* 193 (1976): 871-73.

- McClellan III, James E., and Harold Dorn. *Science and Technology in World History*. 2nd ed. Baltimore: John Hopkins University Press, 2006.
- McFadyen, Alistair. 'Imaging God: A Theological Answer to the Anthropological Question?' *Zygon* 47, no. 4 (2012): 918-33.
- McLeish, Tom. *Faith and Wisdom in Science*. Oxford: Oxford University Press, 2014.
- McMurry, John. *Organic Chemistry*. 4th ed. Pacific Grove: Brooks/Cole 1996.
- Metzger, Bruce M. *A Textual Commentary on the Greek New Testament*. London: United Bible Societies, 1971.
- Middleton, Richard J. *The Liberating Image*. Grand Rapids: Brazos Press, 2005.
- Milton, John. 'Paradise Lost.' 1667.
- Mistry, Sunil. 'A Novel Airframe Design Methodology for Silent Aircraft.' Cranfield, 2008.
- Mistry, Sunil, H. Smith, and John P. Fielding. 'Novel Design Concepts for Aircraft with Reduced Noise and Global Warming Characteristics.' In *26th International Congress of the Aeronautical Sciences*. Anchorage, USA, 2008.
- Mitcham, Carl. 'Technology as a Theological Problem in the Christian Tradition.' in Carl Mitcham and Jim Grote (eds.), *Theology and Technology*: University Press of America, 1984). 3-20.
- . *Thinking through Technology*. 1st ed. Chicago: University of Chicago Press, 1994.
- Mitcham, Carl, and Jim Grote, eds. *Theology and Technology*. Lanham: University Press of America, 1984.
- Mitcham, Carl, and Robert Mackay, eds. *Philosophy and Technology*. 1st paperback ed. New York: The Free Press, 1983.
- Mithen, Stephen. *The Prehistory of the Mind*. London: Phoenix, 1996.
- Moberly, R. W. L., 'Paradigms for Pentateuchal Criticism.' *The Old Testament of the Old Testament*. (Minneapolis: Fortress Press, 1992).
- Morpurgo, J. E. *Barnes Wallis*. London: Penguin, 1973.
- Morris, Leon. *Revelation: An Introduction and Commentary*. Edited by R.V.G. Tasker, *Tyndale New Testament Commentaries*. London: Tyndale Press, 1969.
- Morris, Simon Conway. *The Crucible of Creation*. 1st Paperback ed. Oxford: Oxford University Press, 1998.
- Moule, C. F. D. *The Epistles to the Colossians and to Philemon*. Edited by C. F. D. Moule, *The Cambridge Greek Testament Commentary*. Cambridge: Cambridge University Press, 1962.
- . *The Phenomenon of the New Testament*. London: SCM Press, 1967.
- Mouw, Richard J. *When the Kings Come Marching In*. Grand Rapids: Eerdmans, 1983.
- Mumford, Michael D., Cassie S. Blair, and Richard T. Marcy. 'Alternative Knowledge Structures in Creative Thought: Schema, Associations, and Cases.' in James C. Kaufman and John Baer (eds.), *Creativity and Reason in Cognitive Development*. (New York: Cambridge University Press, 2006). 117-36.
- Munroe, M. Evans. *The Language of Mathematics*. Ann Arbor: University of Michigan Press, 1963.
- Naughton, John. 'Thomas Kuhn: The Man Who Changed the Way the World Looked at Science.' *The Observer*, August 19th 2012.
- Niebuhr, H. Richard. *Christ and Culture*. 1st ed. London: Faber and Faber, 1952.
- Noble, David F. *The Religion of Technology*. New York: Alfred A. Knopf, 1997.
- One-Piece Barrel. In, Boeing, http://www.newairplane.com/787/design_highlights/#/visionary-design/composites/one-piece-barrel. (accessed 23rd August, 2013).
- Oord, Thomas Jay. *The Nature of Love: A Theology*. St Louis, Missouri: Chalice Press, 2010.
- Ormerod, Paul. *Why Most Things Fail*. London: Faber and Faber, 2005.

- Ortega y Gasset, José. 'Thoughts on Technology.' in Carl Mitcham and Robert Mackay (eds.), *Philosophy and Technology*. (New York: Free Press, 1983), Reprint, 1st Paperback. 290 - 313.
- Owen, Jonathan. 2014. Beyond Cern: Now Physicists Prepare to Construct the Even Larger Hadron Collider In, *The Independent*, <http://www.independent.co.uk/news/science/beyond-cern-now-physicists-prepare-to-construct-the-even-larger-hadron-collider-9139495.html>. (accessed 20th February, 2014).
- Pacey, Arnold. *The Culture of Technology*. Oxford: Basil Blackwell, 1983.
- . *The Maze of Ingenuity*. Cambridge, Massachusetts: MIT Press, 1976.
- . *Meaning in Technology*. Cambridge, Massachusetts: MIT Press, 2001.
- Pannenberg, Wolfhart. 'The Doctrine of Creation and Modern Science.' in Ted Peters (ed.), *Cosmos as Creation*, 1st ed. (Nashville: Abingdon Press, 1989). 152-76.
- . *Systematic Theology*. Translated by G. W. Bromiley. 3 vols. Vol. 3. Grand Rapids: William B. Eerdmans, 1998.
- . *Systematic Theology*. Translated by G. W. Bromiley. 3 vols. Vol. 2. Grand Rapids, Michigan: Eerdmans, 1994.
- . *Systematic Theology*. Translated by G. W. Bromiley. 3 vols. Vol. 1. Grand Rapids: William B. Eerdmans, 1991.
- Partington, David (ed.). 'Casualty Compendium.' *Air-Britain Archive* 1999, no. 2 (1999): 63f.
- Pattison, George. *Thinking About God in an Age of Technology*. Oxford: Oxford University Press, 2005.
- Perkin, Harold. *The Origins of Modern English Society 1780 - 1880*. London: Routledge & Kegan Paul, 1972.
- Peters, Ted. *God as Trinity*. Louisville, Kentucky: Westminster/John Knox Press, 1993.
- Pizarro, David A., Brian Detweiler-Bedel, and Paul Bloom. 'The Creativity of Everyday Moral Reasoning.' in James C. Kaufman and John Baer (eds.), *Creativity and Reason in Cognitive Development*. (New York: Cambridge University Press, 2006). 81-98.
- Polanyi, Michael. *Personal Knowledge*. 1st paperback ed. London: Routledge & Kegan Paul, 1973.
- Polanyi, Michael, and Harry Prosch. *Meaning*. Chicago: Chicago University Press, 1977.
- Polkinghorne, John. *Exploring Reality*. New Haven: Yale University Press, 2005.
- . *One World*. London: SPCK, 1986.
- Popper, Karl R. *The Logic of Scientific Discovery*. London: Hutchinson & Co, 1972.
- . *The Open Society and Its Enemies*. 5th paperback ed. Vol. 2. London: Routledge & Kegan Paul, 1966.
- . 'Science: Conjectures and Refutations.' *Conjectures and Refutations*, 5th ed. (London: Routledge and Kegan Paul, 1974). 33-65.
- Pritchard, James B., ed. *Ancient Near Eastern Texts Relating to the Old Testament*. 3rd ed. Princeton: Princeton University Press, 1969.
- Purves, Dale, and R. Beau Lotto. *Why We See What We Do*. Sunderland, Ma. USA: Sinauer Associates, 2003.
- Rabbets, John B. *Barnes Wallis*. Yorkshire Air Museum, Elvington, York: Barnes Wallis Memorial Trust.
- Rivett, Leonard, and Jim Matthew. 'A Yorkshire Genius.' Elvington, York: Yorkshire Air Museum, 1996.
- Robbins, Jeffrey. 'Introductory Note to 'Richard P. Feynman's Minority Report to the Space Shuttle Challenger Inquiry.'.' in Jeffrey Robbins (ed.), *The Pleasure of Finding Things Out*. (London: Penguin Books, 2001). 151-2.
- Robson, Mark I T. *Ontology and Providence in Creation*. London: Continuum, 2008.

- Rogers (Chair), William P. 1986. The Accident. In, NASA, <http://science.ksc.nasa.gov/shuttle/missions/51-l/docs/rogers-commission/Chapter-3.txt>. (accessed March 25th, 2013).
- . 1986. The Cause of the Accident. In, NASA, <http://science.ksc.nasa.gov/shuttle/missions/51-l/docs/rogers-commission/Chapter-4.txt>. (accessed March 25th, 2013).
- . 1986. The Contributing Cause of the Accident. In, NASA, <http://science.ksc.nasa.gov/shuttle/missions/51-l/docs/rogers-commission/Chapter-5.txt>. (accessed March 25th, 2013).
- . 1986. Report of the Presidential Commission on the Space Shuttle Challenger Accident In, NASA, <http://history.nasa.gov/rogersrep/genindex.htm>. (accessed March 25th, 2013).
- . 1986. The Silent Safety Program. In, NASA, <http://science.ksc.nasa.gov/shuttle/missions/51-l/docs/rogers-commission/Chapter-7.txt>. (accessed March 25th, 2013).
- Rookmaaker, Hans R., 'The Creative Gift.' in Marlene Hengelaar-Rookmaaker (ed.), *The Creative Gift, Durer, Dada and Desolation Row*. (Carlisle: Piquant, 2002).
- Rosen, Charles. *Schoenberg*. London: Marion Boyars, 1976.
- Rotman, Brian. *Mathematics as Sign*. Edited by Timothy Lenoir and Hans Ulrich Gumbrecht, *Writing Science*. Stanford Stanford University Press, 2000.
- Runco, Mark A. 'Creativity Has No Dark Side.' in David H Cropley, Arthur J Cropley, James C Kaufman and Mark A Runco (eds.), *The Dark Side of Creativity*. (New York: Cambridge University Press, 2010). 15-32.
- . 'Reasoning and Personal Creativity.' in James C. Kaufman and John Baer (eds.), *Creativity and Reason in Cognitive Development*. (New York: Cambridge University Press, 2006). 99-116.
- Rutan, Bert. Step-by-Step Comparison. In, Rutanboomerang, www.rutanboomerang.com/index.php/design/design-explanation. (accessed 25th July, 2013).
- Sacks, Robert D. *A Commentary on the Book of Genesis, Ancient near Eastern Texts and Studies*. Lewiston, New York: Edwin Mellen Press, 1990.
- Sanders, John. *The God Who Risks*. Downers Grove: InterVarsity Press, 1998.
- Sawyer, R. Keith. *Explaining Creativity. The Science of Human Innovation*. 1st ed. New York: Oxford University Press, 2006.
- Sayers, Dorothy L. *The Mind of the Maker*. London: Methuen, 1941.
- Scaled-Composites. About Us. In, www.scaled.com/about. (accessed July 25th, 2013).
- . Burt Rutan. In, www.scaled.com/about/burt-rutan. (accessed 25th July, 2013).
- Schama, Simon. *Power of Art*. 1st ed. London: BBC Books, 2006.
- Schilling, Harold K. *Science and Religion*. London: George Allen & Unwin, 1963.
- Schuurman, Egbert. 'A Christian Philosophical Perspective on Technology.' in Carl Mitcham and Jim Grote (eds.), *Theology and Technology*: University Press of America, 1984). 107-19.
- Schwöbel, Christoph. 'God, Creation and the Christian Community: The Dogmatic Basis of a Christian Ethic of Createdness.' in Colin E Gunton (ed.), *The Doctrine of Creation*. (London: T&T Clark, 2004). 149 - 76.
- Shute, Nevil. *Slide Rule*. London: Pan Books, 1968.
- Simon, John. *R101: The Airship Disaster: 1930, Uncovered Editions*. London: The Stationery Office, c1999.
- Simonton, Dean K. 'The Creative Process in Picasso's Guernica Sketches.' *Creativity Research Journal* 19, no. 4 (2007): 329-44.
- . 'Creativity from a Historiometric Perspective.' in Robert J. Sternberg (ed.), *Handbook of Creativity*. (Cambridge: Cambridge University Press, 1999). 116-33.

- . 'Picasso's *Guernica* Creativity as a Darwinian Process.' *Creativity Research Journal* 19, no. 4 (2007): 381-94.
- . 'So You Want to Become a Creative Genius? You Must Be Crazy!', in David H Cropley, Arthur J Cropley, James C Kaufman and Mark A Runco (eds.), *The Dark Side of Creativity*. (New York: Cambridge University Press, 2010).
- Southgate, Christopher. *The Groaning of Creation*. Louisville, Kentucky: Westminster John Knox Press, 2008.
- Sparrow, Betsy, Jenny Liu, and Wegner. Daniel M. 'Google Effects on Memory: Cognitive Consequences of Having Information at Our Fingertips.' *Science* 333 (2011): 776-78.
- Spufford, Francis. *Backroom Boys*. London: Faber & Faber, 2003.
- Steffen, Alex. 2011. The Shareable Future of Cities. In, TED, http://www.ted.com/talks/alex_steffen.html. (accessed January 28th, 2013).
- Steiner, George. *Grammars of Creation*. London: Faber and Faber, 2001.
- Sternberg, Robert J., 'Dark Side of Creativity and How to Combat It.' in David H Cropley, Arthur J Cropley, James C Kaufman and Mark A Runco (eds.), *The Dark Side of Creativity*. (New York: Cambridge University Press, 2010). 316-28.
- Stewart, Ian. 2012. The Mathematical Equation That Caused the Banks to Crash. In, The Guardian, <http://www.guardian.co.uk/science/2012/feb/12/black-scholes-equation-credit-crunch>. (accessed 11th March, 2013).
- Stinton, Darrol. 'The Structural Revolution.' in Philip Jarrett (ed.), *Biplane to Monoplane*. (London: Putnam, 1997). 127-39.
- Stroud, John. 'Airliner Evolution in the Postwar Era.' in Philip Jarrett (ed.), *Modern Air Transport*. (London: Putnam, 2000).
- . 'The Evolution of Transport Aircraft.' in Philip Jarrett (ed.), *Biplane to Monoplane*. (London: Putnam, 1997). 29-53
- Summers, Joseph H, ed. *George Herbert: Selected Poetry*. Edited by John Hollander. 1st ed, *The Signet Classic Poetry Series*. New York: New American Library, 1967.
- Sun, P.Hans. 'Notes on How to Begin to Think About Technology in a Theological Way.' in Carl Mitcham and Jim Grote (eds.), *Theology and Technology*: University Press of America, 1984). 171-92.
- The Sveriges Riksbank Prize in Economic Sciences in Memory of Alfred Nobel 1997. 1997. In, Nobelprize.org, http://www.nobelprize.org/nobel_prizes/economics/laureates/1997/. (accessed 11th March, 2013).
- Szerszynski, Bronislaw. *Nature, Technology and the Sacred*. 1st ed. Oxford: Blackwell, 2005.
- Taleb, Nassim N. *Foiled by Randomness. The Hidden Role of Chance in Life and the Markets*. London: Penguin Books, 2007.
- Taylor, Charles. *A Secular Age*. 1st ed. Cambridge, Massachusetts: Belknap Press of Harvard University Press, 2007.
- Taylor, John V. *The Christlike God*. 2nd ed. London: SCM Press, 2004.
- Tekippe, Terry. 'Bernard Lonergan: A Context for Technology.' in Carl Mitcham and Jim Grote (eds.), *Theology and Technology*: University Press of America, 1984). 71-90.
- Terlizzese, Lawrence A. *Trajectory of the 21st Century*. 1st ed. Eugene, Oregon: Resource Publications, 2009.
- Thisdell, Dan. 2011. UK Researchers Unveil Silent Aircraft Concept. In, Flightglobal, <http://www.flightglobal.com/news/articles/uk-researchers-unveil-silent-aircraft-concept-364961/>. (accessed 26th July, 2013).
- Thomas, D. Winton, ed. *Documents from Old Testament Times*. London: Thomas Nelson and Sons, 1958.

- Thomas, John Heywood. 'The Problem of Defining a Theology of Culture with Reference to the Theology of Paul Tillich.' in Richard W.A. McKinney (ed.), *Creation Christ and Culture*. (Edinburgh: T. & T. Clark, 1976). 272-87.
- Thompson, Richard P., 'Authority Is What Authority Does.' in Richard P. Thompson and Thomas Jay Oord (eds.), *The Bible Tells Me So (Kindle Edition)*, Kindle ed. (Nampa, Idaho: SacraSage Press, 2011). Loc 804 -1092.
- Tigay, Jeffrey H. *The Evolution of the Gilgamesh Epic*. Philadelphia: University of Pennsylvania Press, 1982.
- Tillich, Paul. *Systematic Theology*. Combined ed. 3 vols. Vol. 3. Digswell Place, Welwyn, Herts: James Nisbet & Co, 1968.
- Tipler, Frank J. *The Physics of Immortality*. New York: Anchor/Doubleday, 1995.
- Torrance, Thomas F. *Divine and Contingent Order*. 1st ed. Oxford: Oxford University Press, 1981.
- . *Space, Time and Incarnation*. London: Oxford University Press, 1969.
- . *Space, Time and Resurrection*. Edinburgh: The Handsel Press, 1976.
- Toynbee, Arnold. *Mankind and Mother Earth*. London: Book Club Associates, 1976.
- Trible, Phyllis. *God and the Rhetoric of Sexuality*. Philadelphia: Fortress Press, 1978.
- Turner, N., 'Revelation.' in Matthew Black and H. H. Rowley (eds.), *Peake's Commentary on the Bible*. (London: Thomas Nelson and Sons, 1962).
- Van Huyssteen, J. Wentzel. *Alone in the World?* Grand Rapids: William B. Eerdmans, 2006.
- Vanhoozer, Kevin J. *Is There a Meaning in This Text?* Leicester: Apollos (IVP), 1998.
- Veblen, Thorstein. *The Instinct of Workmanship, The Collected Works of Thorstein Veblen*. London: Routledge/Thoemmes Press, 1994.
- Walton, John H. *Ancient Israelite Literature in Its Cultural Context*. Grand Rapids: Zondervan, 1989.
- Warnock, Mary. *Imagination*. London: Faber and Faber, 1976.
- Waters, Brent. *From Human to Posthuman*. Edited by Roger Trigg and J. Wentzel Van Huyssteen, *Ashgate Science and Religion Series*. Aldershot: Ashgate, 2006.
- Watts, Rikki E., 'On the Edge of the Millenium: Making Sense of Genesis 1.' in Hans Boersma (ed.), *Living in the Lamblight*. (Vancouver: Regent College Publishing, 2001).
- Weinberg, Stephen. *The First Three Minutes*. London: Flamingo/Fontana Paperbacks, 1984.
- Weisberg, Robert W., 'Creativity and Knowledge: A Challenge to Theories.' in Robert J. Sternberg (ed.), *Handbook of Creativity*. (Cambridge: Cambridge University Press, 1999). 226-50.
- Wenham, Gordon J. *Genesis 1 - 15*. Edited by John D. W. Watts, *Word Biblical Commentary*. Waco, Texas: Word Books, 1987.
- West, Geoffrey. 2011. The Surprising Math of Cities and Corporations. In, TED, http://www.ted.com/talks/geoffrey_west_the_surprising_math_of_cities_and_corporations.html. (accessed November 29th, 2012).
- Westermann, Claus. *Genesis 1-11: A Continental Commentary*. Translated by John J. Scullion. Minneapolis: Fortress Press, 1994.
- . *Genesis 12-36: A Continental Commentary*. Translated by John J. Scullion. Minneapolis: Fortress, 1995.
- White Jr., Lynn. 'The Historical Roots of Our Ecological Crisis.' in Carl Mitcham and Robert Mackey (eds.), *Philosophy and Technology*. (New York: The Free Press, 1983). 259 - 65.
- Whitford, Ray. 'Structures and Materials.' in Philip Jarrett (ed.), *Modern Air Transport*. (London: Putnam, 2000). 67-80.
- Wilcock, Michael. *I Saw Heaven Opened: The Message of Revelation*. Edited by John R.W. Stott, *The Bible Speaks Today*. London: Inter-Varsity Press, 1975.
- Wilkinson, David. *Christian Eschatology and the Physical Universe*. 1st ed. London: T & T Clark International, 2010.
- Winslow, Karen Strand. 'The Earth Is Not a Planet.' in Thomas Jay Oord (ed.), *Creation Made Free*, Kindle ed. (Eugene, Oregon: Wipf and Stock, 2009). Loc 221 - 611.

- Wolpert, Lewis. *The Unnatural Nature of Science*. London: Faber and Faber, 1992.
- Wright, N. T. *The Resurrection of the Son of God*. London: SPCK, 2003.
- Wright, Orville. 'How We Invented the Airplane.' in Fred C. Kelly (ed.), *How We Invented the Airplane*. (New York: Dover Publications, 1988). 11-21.
- Wright, Tom. *Surprised by Hope*. London: SPCK, 2007.
- Yarwood, A. *Graphical Communication: Book 1*. 2nd ed. Walton-on-Thames: Thomas Nelson and Sons, 1984.
- Young, Rosamund, and Catharine Fitzgerald. *Twelve Seconds to the Moon*. Dayton, Ohio: United States Air Force Museum Foundation, 1983.
- Zaitseva, Maria N., 'Subjugating the Creative Mind.' in David H Cropley, Arthur J Cropley, James C Kaufman and Mark A Runco (eds.), *The Dark Side of Creativity*. (New York: Cambridge University Press, 2010).
- Zizioulas, John D. 'Preserving God's Creation.' *King's Theological Review* 13:1 (1990).