

Durham E-Theses

*Exploitation of small cysteine-rich spider protein
toxins as bio-insecticides*

SHENG YANG

How to cite:

YANG, SHENG (2015) Exploitation of small cysteine-rich spider protein toxins as bio-insecticides. Doctoral thesis, Durham University.

Use policy

The full-text may be used and/or reproduced, and given to third parties in any format or medium, without prior permission or charge, for personal research or study, educational, or not-for-profit purposes provided that:

- a full bibliographic reference is made to the original source
- a <https://etheses.durham.ac.uk/id/eprint/11035/> is made to the metadata record in Durham E-Theses
- the full-text is not changed in any way

The full-text must not be sold in any format or medium without the formal permission of the copyright holders.

Please consult the [full Durham E-Theses policy](#) for further details.

EXPLOITATION OF SMALL CYSTEINE-RICH SPIDER PROTEIN TOXINS AS BIO-INSECTICIDES

A thesis submitted by Sheng Yang, BSc MSc (R) in accordance with the requirements of Durham University for the degree of Doctor of Philosophy

Department of Biological and Biomedical Sciences

Durham University

November 2014

Exploitation of small cysteine-rich spider protein toxins as bio-insecticides

Sheng Yang

Abstract

Recombinant fusion protein technology allows specific insecticidal protein and peptide toxins to display activity in orally-delivered bio-pesticides. Here, some small cysteine-rich protein toxins were evaluated as insecticides, including δ -amaurobitoxin-P11a (P11a) from tangled nest spider (*Pireneitega luctuosa*), ω -atracotoxin-Hv1a (Hv1a) from funnel web spider (*Hadronyche versuta*) and κ -theraphotoxin-Ec2a (Ec2a) from *Eucratoscelus constrictus*, which target insect voltage-gated sodium channels, calcium activated potassium channels and voltage-regulated potassium channels, respectively. Recombinant proteins were produced using the yeast *Pichia pastoris* as expression host, by combining the coding sequences of the toxin with that of snowdrop lectin ("carrier"), that can deliver these toxins to the central nervous system of the target pest.

Experimental results showed the toxins alone had limited or even no activities without being fused to the N-terminal of snowdrop lectin "carrier". Further, fusion of toxins to proteins other than snowdrop lectin also gave products with low or no biological activity. The absence of biological activity suggested that the toxin protein was not folding properly when expressed without fusion to the snowdrop lectin carrier, which meant GNA could not only direct transport of the toxins across the insect gut as a carrier, but also can help toxins to achieve correct folding. For example, the toxin P11a and a P11a/GNA fusion protein both caused mortality when injected into cabbage moth (*Mamestra brassicae*) larvae, but the P11a/GNA fusion protein was approximately 6 times as effective as recombinant P11a on a molar basis. P11a alone was not orally active against cabbage moth larvae, but a single 30 μ g dose of the P11a/GNA fusion protein caused 100% larval mortality within 6 days when fed to 3rd instar larvae, and caused significant reductions in survival, growth and feeding in 4th - 6th instar larvae.

To attempt to further improve the folding of recombinant fusion proteins, the predicted Pro-regions of toxins, between the signal peptide and the final mature sequence of the protein were examined. Inclusion of the Pro-region in the expression

Abstract

construct was hypothesised to result in improved folding of the toxin when expressed in *P. pastoris*. The results proved that the new type fusion protein (Pro-region/toxin/GNA) had much higher biological activity than toxins alone and higher activity than toxin/GNA fusion proteins. In addition, the Pro-region was successfully removed from the Pro-region/toxin/GNA proteins after expression. For example, the LD₅₀ of Pro-Hv1a/GNA was decreased by 12 fold compared to Hv1a/GNA when injected into *Mamestra brassicae* larvae of different stages of development. Increased biological activity of Pro-Hv1a/GNA when compared to Hv1a/GNA was also observed when the proteins were injected into slugs. The increased biological activity of Pro-Hv1a/GNA on injection was also observed as increased oral toxicity of the fusion protein to insects. A single dose (20 µg) of fusion protein Hv1a/GNA caused no mortality to 5th instar larvae of *M. brassicae*, or 30% mortality to 3rd instar larvae; in contrast, 20 µg Pro-Hv1a/GNA caused 30% mortality to 5th instar larvae, and 90% mortality to 3rd instar larvae.

Fusion proteins have the potential to be a new class of bio-pesticides for commercial application and have potential uses in complementing or replacing existing pesticides. Insecticide-resistant strains of peach potato aphid (*Myzus persicae*), designated "*kdr*", "*super-kdr*" and "*kdr+super-kdr*" contain mutations in the voltage-gated sodium channel (NaCh). P11a/GNA and Pro-Hv1a/GNA fusion proteins have the LC₅₀ values of 0.35 and 0.19 mg ml⁻¹ when fed to wild-type *M. persicae*. For insecticide-resistant aphids, the LC₅₀ for the P11a/GNA fusion protein, which targets NaCh, was increased by 2-6 fold correlating with pyrethroid resistance (wild-type < *kdr* < *super-kdr* < *kdr+super-kdr* strains). In contrast, the LC₅₀ for the Pro-Hv1a/GNA, which targets calcium channels, showed limited correlation with pyrethroid resistance. Therefore, mutations in the sodium channel in pyrethroid-resistant aphids also protect against a fusion protein containing a sodium channel-specific toxin, despite differences in ligand-channel interactions. This may be because changes to the spatial structure of domain II as a result of these mutations presumably also disturb the binding of P11a to receptor site 4, in domain II of sodium ion channel. However, mutations in the sodium channel do not confer resistance to a fusion protein targeting calcium channels. The use of fusion proteins with differing targets could delay resistance development in *M. persicae*.

Table of Contents

ABSTRACT	I
TABLE OF CONTENTS.....	III
LIST OF FIGURES.....	VII
LIST OF TABLES	XII
LIST OF ABBREVIATIONS	XIII
DECLARATION AND STATEMENT OF COPYRIGHT	XVII
LIST OF PUBLICATIONS.....	XVII
ACKNOWLEDGEMENTS	XVIII
CHAPTER 1 INTRODUCTION.....	1
1.1 INSECTS AS CROP PESTS	1
1.1.1 Crop pests.....	1
1.1.2 Insect pests towards Humans.....	5
1.2 AGRICULTURE AND INSECT PESTS	5
1.3 HAZARDS OF PESTICIDES TO HUMAN BEINGS AND ENVIRONMENT.....	6
1.4 ENVIRONMENTALLY COMPATIBLE TECHNOLOGY OF PEST CONTROL: INSECTICIDAL PEPTIDE PROTEINS FROM SPIDER IN FUSION WITH "CARRIER", "VECTOR" OR "COAT" PROTEINS AS NOVEL BIO-INSECTICIDES	9
1.4.1. Neurotoxins from spider venoms as one of the components of insecticidal fusion proteins. 9	
1.4.1.(i) Peptide proteins from spider venoms.....	9
1.4.1.(ii). Insecticidal venom peptide synthesis: the role of a predicted Pro-region.....	13
1.4.2. "Carrier", "vector" or "coat" protein as another component of insecticidal fusion proteins.14	
1.4.2.1. <i>Snowdrop lectin acting as a "carrier" domain in spider fusion proteins.....</i>	15
1.4.2.1.(i) Snowdrop lectin (<i>Galanthus nivalis agglutinin</i> ; GNA).....	15
1.4.2.1.(ii) Fusion of spider neurotoxins to GNA as recombinant fusion proteins.....	19
1.4.2.1.(iii) Vector constructs of recombinant fusion proteins.....	20
1.4.2.1.(iv) Toxin from the Australian funnel web spider (<i>Hadronyche versuta</i>) and its use in fusion to GNA.....	21
1.4.2.2. <i>Engineered insect pathogens that directs delivery by acting as the "vector" of spider toxins, Bt toxins or spider/Bt fusion toxins.....</i>	24
1.4.2.2.(i) Insect pathogens acting as a "vector" of spider toxins	24
1.4.2.2.(ii) <i>Bacillus thuringiensis</i> (Bt) toxins and their use in transgenic plant and engineered baculoviruses	25
1.4.2.2.(iii) Baculoviruses acting as a "vector" of spider/Bt fusion toxins.....	28
1.4.2.3. <i>Plant virus proteins that mediate delivery by acting as the "coat"</i>	29
1.4.2.3.(i) Plant virus proteins.....	29
1.4.2.3.(ii) Application of Plant virus proteins.....	29
1.4.2.3.(iii) Plant virus proteins acting as a "coat" protein of spider peptide toxins.....	30
1.4.3. Expression of spider toxins and their fusion proteins.....	30
1.4.3.(i) Expression of spider peptide proteins using bacterial expression systems.....	30
1.4.3.(ii) Expression of spider toxins and their fusion proteins using yeast expression systems	31
1.5 THE APPLICATIONS OF SPIDER TOXINS AND THEIR FUSION PROTEINS IN PHARMACY AND IN CROP PROTECTION.....	34
1.5.1 Spider neurotoxins as leads for drug development	34
1.5.2 Applications of spider toxins for control of insect pests as bio-insecticides	35
1.5.3. Engineering spider toxins or their fusion proteins into crop plants using transgenesis technology	37
1.6 AIMS AND OBJECTIVES:	38
CHAPTER 2 MATERIALS AND METHODS.....	40
2.1 CHEMICALS AND REAGENTS	40
2.2 INSECT REARING	40
2.2.1 <i>Mamestra brassicae</i> (cabbage moth)	40
2.2.2 Cereal aphid (<i>Sitobion avenae</i> F.) and pea aphid (<i>Acyrtosiphon pisum</i>)	40
2.2.3 Wild-type <i>Myzus persicae</i> (Sulzer) (Hemiptera: Aphididae) (peach-potato aphid) strain	40

Table of Contents

(4106A) and pyrethroid-resistance <i>Myzus</i> strains (794J, UKO and 4824J).....	40
2.2.4 <i>Musca domestica</i> (housefly).....	41
2.3 STATISTICAL ANALYSIS	41
2.4 STANDARD MOLECULAR BIOLOGICAL TECHNIQUES	41
2.4.1 Oligonucleotides	41
2.4.2 Bacterial culture technology	41
2.4.3 Plasmid DNA mini-preparations	42
2.4.4 Restriction endonuclease digestions.....	42
2.4.5 Polymerase chain reactions (PCR).....	42
2.4.6 Agarose gel electrophoresis of DNA.....	43
2.4.7 Purification of DNA from agarose gel.....	43
2.4.8 Quantification of isolated DNA.....	43
2.4.9 Ligation of DNA.....	43
2.4.10 Directed base site mutagenesis.....	43
2.4.11 Ethanol precipitation	44
2.4.12 Preparation of Electro-competent cells TOP10.....	44
2.4.13 Transformation of TOP 10 electrocompetent <i>E. coli</i>	45
2.4.14 Colony PCR.....	45
2.4.15 DNA sequencing and analysis	45
2.4.16 Glycerol stocks of <i>E.coli</i> clones	46
2.5 STANDARD PROTEIN BIOLOGICAL TECHNIQUES	46
2.5.1 SMD1168H of the genotype <i>pep4</i> strains of <i>Pichia pastoris</i> yeast competent cells preparation (Invitrogen).....	46
2.5.2 Linearization of plasmid DNA	46
2.5.3 Transformation of competent cells of <i>Pichia pastoris</i> yeast.....	47
2.5.4 SDS-PAGE gel electrophoresis for proteins (>10 kDa)	47
2.5.5 Tris-Tricine gel electrophoresis for small proteins or peptides (<10 kDa).....	48
2.5.6 SDS-PAGE gels staining with Coomassie Brilliant Blue and de-staining via de-staining buffer	48
2.5.7 Western blot analysis.....	49
2.5.7.(i) Solutions required.....	49
2.5.7.(ii) The protocol of western blot.....	49
2.5.8 Estimation of protein concentration.....	50
2.5.9 Protein sequencing.....	51
2.5.10 Proteins labeling with fluorescein isothiocyanate (FITC).....	51
2.6 LARGE-SCALE PRODUCTION OF SPIDER RECOMBINANT INSECTICIDES AND THEIR FUSION PROTEINS IN <i>PICHIA PASTORIS</i>	52
2.6.1 Expression constructs of recombinant insecticides and fusion proteins	52
2.6.1.(i) Recombinant GNA protein construct.....	52
2.6.1.(ii) δ -Amaurobitoxin-Pl1a (Pl1a) and Ao1bPro-Pl1a constructs.....	52
2.6.1.(iii) Pl1a/GNA, Ao1bPro-Pl1a/GNA, Hv1aPro-Pl1a/GNA and Mod-Pl1a/GNA constructs.....	53
2.6.1.(iv) Hv1a, Pro-Hv1a and Pro-Hv1a/GNA constructs.....	54
2.6.1.(v) Ec2a/GNA and Pro-Ec2a/GNA constructs.....	56
2.6.2 Transformation of recombinant protein expression constructs in <i>P. pastoris</i>	57
2.6.3 Expression and western blot detection of transformed <i>P. pastoris</i> colonies	57
2.6.4 Large-scale expression (fermentation) of recombinant proteins in <i>P. pastoris</i>	57
2.6.5 Purification of recombinant proteins	58
2.6.5.(i) Purification of recombinant proteins by nickel affinity chromatography.....	58
2.6.5.(ii) Purification of recombinant proteins by gel filtration chromatography	58
2.6.6 Dialysis and freeze-drying of recombinant proteins	59
2.6.7 Insect pest bioassays	59
2.6.7.(i) <i>Mamestra brassicae</i> injection bioassays	59
2.6.7.(ii) <i>Musca domestica</i> injection bioassays.....	59
2.6.7.(iii) <i>Mamestra brassicae</i> drop-feeding bioassays.....	60
2.6.7.(iv) <i>Musca domestica</i> drop-feeding bioassays.....	60
2.6.7.(v) Cereal aphid (<i>Sitobion avenae</i> F.) and pea aphid (<i>Acyrtosiphon pisum</i>) drop-feeding bioassays.....	60
2.6.7.(vi) Drop-feeding bioassays of pyrethroid-resistant peach-potato aphid (<i>Myzus persicae</i>)	60
2.6.7.(vii) Injection bioassays: <i>Deroceras reticulatum</i> (mollusc grey field slug).....	61
2.6.8 Total protein extraction from the gut, haemolymph, Malpighian tubules, fat body and nerve chord of <i>M. brassicae</i>	61
2.6.9 Detecting binding of recombinant proteins to aphid gut surface	62
2.7 CONSTRUCTION OF PLASMIDS CONTAINING GL-PRO-HV1A-GNA AND GENERATION OF TRANSGENIC ARABIDOPSIS	62

Table of Contents

2.7.1 Pro-Hv1a/GNA based expression constructs	62
2.7.2 Cloning GL-Pro-Hv1a-GNA construct into plant expression vectors using the Gateway™ cloning system	63
2.7.2.(i) Subcloning GL-Pro-Hv1a-GNA construct into entry vector pENTR™/D-TOPO.....	63
2.7.2.(ii) Generation of an expression vector containing GL-Pro-Hv1a-GNA fragment.....	63
2.8 GENERATION OF TRANSGENIC ARABIDOPSIS LINES	63
2.8.1 Transformation of pEarlyGate 100 plasmid containing GL-Pro-Hv1a-GNA into Arabidopsis using <i>Agrobacterium tumefaciens</i> system.....	64
2.8.2 Arabidopsis growth conditions.....	64
2.8.3 Transformation by floral dipping.....	64
2.8.4 Seed collection.....	65
2.8.5 Seed sterilisation.....	65
2.8.6 Screen for homozygous transformed Arabidopsis lines.....	65
2.9 ANALYSIS OF TRANSFORMED PLANTS.....	65
2.9.1 Extraction of total protein from leaf tissues.....	65
2.9.2 Analysis of protein expression by western blotting	66
CHAPTER 3 EXPRESSION OF RECOMBINANT SPIDER INSECTICIDAL NEUROTOXINS AND THEIR FUSION PROTEINS.....	67
INTRODUCTION.....	67
3.1 CONSTRUCTION OF RECOMBINANT PL1A AND Ao1BPRO-PL1A TOXINS; PL1A/GNA, Ao1BPRO-PL1A/GNA AND Hv1APro-PL1A/GNA FUSION PROTEINS; RECOMBINANT Hv1A AND PRO-Hv1A TOXINS; Hv1A/GNA AND PRO-Hv1A/GNA FUSION PROTEINS; RECOMBINANT AS1C TOXIN AND AS1C/GNA FUSION PROTEIN; EC2A AND PRO-EC2A TOXINS; EC2A/GNA AND PRO-EC2A/GNA FUSION PROTEINS.....	68
3.2 EXPRESSION AND PURIFICATION OF RECOMBINANT TOXINS AND FUSION PROTEINS.....	79
DISCUSSION.....	81
SUMMARY	85
CHAPTER 4 RECOMBINANT SPIDER TOXIN PL1A, SPECIFIC FOR THE INSECT VOLTAGE-GATED SODIUM ION CHANNELS, SHOWS ORAL TOXICITY TOWARDS INSECTS OF DIFFERENT ORDERS WHEN FUSED TO GNA.....	86
INTRODUCTION.....	86
4.1 CHARACTERIZATION OF RECOMBINANT PL1A AND PL1A/GNA.....	87
.....	90
PL1A/GNA FUSION PROTEIN N-TERMINAL SEQUENCING RESULTS. FIVE AMINO ACIDS WERE SEQUENCED (NH ₂ -GLU-ALA-ALA-ALA-GLY).	90
4.2 CHARACTERIZATION OF RECOMBINANT Ao1BPRO-PL1A, Ao1BPRO-PL1A/GNA AND Hv1APro-PL1A/GNA.....	91
4.3 BIOASSAYS OF RECOMBINANT TOXINS PL1A AND Ao1BPRO-PL1A; PL1A/GNA, Ao1BPRO-PL1A/GNA AND Hv1APro-PL1A/GNA FUSION PROTEINS TO CABBAGE MOTH LARVAE	98
4.3.1 Toxicities of recombinant Pl1a and Pl1a/GNA fusion protein to cabbage moth larvae after injection into the haemolymph	98
4.3.2 Toxicity of the Pl1a/GNA fusion protein to cabbage moth larvae after oral delivery.....	99
4.3.3 Detection of ingested Pl1a/GNA in cabbage moth larval tissues after oral delivery.....	103
4.3.4 Toxicities of recombinant Ao1bPro-Pl1a; Ao1bPro-Pl1a/GNA and Hv1aPro-Pl1a/GNA fusion proteins to cabbage moth larvae after injection into the haemolymph	106
4.3.5 Toxicities of Ao1bPro-Pl1a/GNA and Hv1aPro-Pl1a/GNA fusion proteins to cabbage moth larvae after oral delivery.....	109
4.4 EFFECTS OF RECOMBINANT PL1A TOXIN, PL1A/GNA, Ao1BPRO-PL1A/GNA AND Hv1APro-PL1A/GNA FUSION PROTEINS ON HOUSEFLIES.....	112
4.4.1 Toxicities of recombinant Pl1a toxin and Pl1a/GNA fusion proteins to houseflies	112
4.4.2 Toxicities of Ao1bPro-Pl1a/GNA and Hv1aPro-Pl1a/GNA fusion proteins to houseflies....	114
4.5 EFFECTS OF ORAL DELIVERY OF PL1A/GNA FUSION PROTEIN ON PEA APHIDS.....	117
DISCUSSION.....	121
SUMMARY	125
CHAPTER 5 ADDITION OF NATIVE PRO-REGION TO OMEGA-ATRACOTOXIN (HV1A) IN A RECOMBINANT FUSION PROTEIN WITH GNA (PRO-HV1A/GNA) RESULTS IN SIGNIFICANTLY ENHANCED INSECTICIDAL ACTIVITY AS COMPARED TO HV1A/GNA	126
INTRODUCTION.....	126
5.1 CHARACTERIZATIONS OF RECOMBINANT Hv1A, PRO-Hv1A AND PRO-Hv1A/GNA.....	127

Table of Contents

5.2 INJECTION BIOASSAYS OF RECOMBINANT HV1A AND PRO-HV1A TOXINS; PRO-HV1A/GNA FUSION PROTEIN TO CABBAGE MOTH LARVAE	133
5.3 FEEDING BIOASSAYS OF RECOMBINANT HV1A/GNA AND PRO-HV1A/GNA TO CABBAGE MOTH LARVAE	137
5.4 DETECTION OF INGESTED PRO-HV1A/GNA IN THE HAEMOLYMPH OF <i>M. BRASSICAE</i> LARVAE BY WESTERN BLOTTING	140
5.5 INGESTION TOXICITY OF PRO-HV1A/GNA FUSION PROTEIN TO PEA APHIDS, CEREAL APHIDS AND PEACH-POTATO APHIDS.....	142
DISCUSSION.....	144
SUMMARY.....	148
CHAPTER 6 EFFECT OF INSECTICIDAL FUSION PROTEINS CONTAINING SPIDER TOXINS TARGETING SODIUM AND CALCIUM ION CHANNELS ON PYRETHROID-RESISTANT STRAINS OF PEACH-POTATO APHID (<i>MYZUS PERSICAE</i>).....	149
INTRODUCTION.....	149
6.1 TOXICITY OF SEPARATE COMPONENTS OF FUSION PROTEINS	152
6.2 TOXICITY OF PL1A/GNA RECOMBINANT FUSION PROTEIN	154
6.3 TOXICITY OF PRO-HV1A/GNA RECOMBINANT FUSION PROTEIN	157
4. DISCUSSION	159
CHAPTER 7 GENERAL DISCUSSION AND CONCLUSIONS.....	162
7.1 SPIDER VENOM PEPTIDE NEUROTOXINS AS NEW SOURCE OF BIO-INSECTICIDES FOR CROP PROTECTION.....	162
7.2 THE ADVANTAGES OF FUSION PROTEINS IN THE FUTURE COMMERCIAL APPLICATION.....	163
7.3 THE CHALLENGES THAT NEED TO BE ADDRESSED FOR TOXIC SPIDER FUSION PROTEINS.....	168
7.4 CONCLUSIONS.....	169
REFERENCES	170
APPENDICES.....	194

List of Figures

Chapter 1 Introduction

Figure 1.1 The pesticide cycle in the environment when absorbed by crop plants.

Figure 1.2 The spider toxin Amaurobitoxin-PI1a, Uniprot P83256 (PI1a) structure PDB1V90.

Figure 1.3 GNA PDB structure.

Figure 1.4 Molecular surface of the three-dimensional structure of the β -hairpin of ω -ACTX-Hv1a, which showed the proposed interaction between residues in the β -hairpin and insect voltage-gated calcium channels.

Figure 1.5 Schematic of insect control options available for spider toxins.

Chapter 3 Expression of recombinant spider insecticidal neurotoxins and their fusion proteins

Figure 3.1 Diagrammatic representation of PI1a (A) and PI1A/GNA (B) constructs with restriction sites integrated into pGAPZ α B, respectively.

Figure 3.2 Sequences of predicted products from expression constructs for PI1a toxin (A) and PI1a/GNA fusion protein (B).

Figure 3.3 Diagrammatic representation of recombinant Ao1bPro-PI1a (A), Ao1bPro-PI1a/GNA (B) and Hv1aPro-PI1a/GNA (C) constructs with restriction sites integrated into pGAPZ α B, respectively.

Figure 3.4 Sequences of predicted products from expression constructs for Ao1bPro-PI1a (A), Ao1bPro-PI1a/GNA (B) and Hv1aPro-PI1a/GNA (C).

Figure 3.5 Diagrammatic representation of recombinant Hv1a (A), Pro-Hv1a (B), Hv1a/GNA (C) and Pro-Hv1a/GNA (D) constructs with restriction sites integrated into pGAPZ α B, respectively.

Figure 3.6 Sequences of predicted products from expression constructs for Hv1a (A), Pro-Hv1a (B), Hv1a/GNA (C) and Pro-Hv1a/GNA (D).

Figure 3.7 Diagrammatic representations of As1c toxin (A) and As1c/GNA fusion protein (B) constructs with restriction sites integrated into pGAPZ α B.

Figure 3.8 Sequences of predicted products from expression constructs for As1c toxin (A) and As1c/GNA fusion protein (B).

Figure 3.9 Diagrammatic representations of Ec2a toxin (A), Pro-Ec2a toxin (B), Ec2a/GNA (C) and Pro-Ec2a/GNA fusion proteins (D) constructs with restriction sites integrated into pGAPZ α B.

Figure 3.10 Sequences of predicted products from expression constructs for Ec2a (A), Pro-Ec2a (B), Ec2a /GNA (C) and Pro-Ec2a /GNA (D).

Figure 3.11 Western blotting analysis of clones of recombinant P11a/GNA and Pro-Hv1a/GNA fusion proteins from shake-flask yeast cultures using anti-GNA tag.

Figure 3.12 The roles of different amino acid residues in determining binding and toxicity of P11a toxin.

Chapter 4 Recombinant spider toxin P11a, specific for the insect voltage-gated sodium ion channels, shows oral toxicity towards insects of different orders when fused to GNA

Figure 4.1 Characterisation of purified recombinant proteins by SDS-PAGE followed by Coomassie blue staining.

Figure 4.2 P11a/GNA fusion protein N-terminal sequencing results.

Figure 4.3 Characterisation of purified recombinant Ao1bPro-P11a toxin.

Figure 4.4 Ao1bPro-P11a Protein N-terminal sequencing results.

Figure 4.5 Characterization of purified recombinant Ao1bPro-P11a/GNA and Hv1aPro-P11a/GNA fusion proteins by SDS-PAGE.

Figure 4.6 Ao1bPro-P11a/GNA fusion protein N-terminal sequencing results.

Figure 4.7 Hv1aPro-P11a/GNA fusion protein N-terminal sequencing results.

Figure 4.8 Quantifications of purified recombinant Hv1aPro-P11a/GNA (A) and Ao1bPro-P11a/GNA (B) fusion proteins.

Figure 4.9 Injection bioassays of P11a and P11a/GNA against larvae of cabbage moth (*M. brassicae*).

Figure 4.10 Feeding bioassays of P11a and P11a/GNA against larvae of cabbage moth (*M. brassicae*).

Figure 4.11 Transport of P11a/GNA fusion protein from gut contents to haemolymph, Malpighian tubules, fat body and nerve chord in larvae of cabbage moth (*Mamestra brassicae*).

Figure 4.12 Survival of fifth stadium *M. brassicae* larvae following injection of different doses of (A) Ao1b-ProP11a (Dose A: P11a; Dose B: Ao1bPro

P11a) (B) Ao1b-ProP11a/GNA and (C) Hv1aPro-P11a/GNA.

Figure 4.13 Ingestion toxicity of recombinant P11a/GNA, Ao1bPro-P11a/GNA and Hv1aPro-P11a/GNA to *Mamestra brassicae*

Figure 4.14 Bioassays of P11a and P11a/GNA against adults of housefly (*Musca domestica*).

Figure 4.15 Bioassays of Ao1bPro-P11a/GNA and Hv1aPro-P11a/GNA fusion proteins against *M. domestica*.

Figure 4.16 Bioassays of P11a/GNA fusion protein against nymphs of pea aphid (*Acyrtosiphon pisum*).

Figure 4.17 Aphids' size after exposure for 6 days from neonate to diets containing P11a (Amaurobitoxin), snowdrop lectin (GNA) or P11a/GNA fusion protein (Amaurobitoxin/GNA) at concentrations as indicated. (A) Aphids' length. (B) Aphids' width.

Chapter 5 Addition of Pro-region to omega-atracotoxin (Hv1a) in a recombinant fusion protein with GNA (Pro-Hv1a/GNA) results in significantly enhanced insecticidal activity as compared to Hv1a/GNA

Figure 5.1 Characterisation of purified recombinant proteins Hv1a and Pro-Hv1a.

Figure 5.2 Characterisation of purified recombinant Hv1a/GNA and Pro-Hv1a/GNA fusion proteins.

Figure 5.3 Pro-Hv1a/GNA fusion Protein N-terminal sequencing results.

Figure 5.4 Quantifications of purified recombinant Pro-Hv1a /GNA (A) and Hv1a/GNA (B) by 17.5% acrylamide SDS-PAGE gel.

Figure 5.5 Survival recorded for newly enclosed 3rd-5th instar larvae of *M. brassicae* following the injection of different doses of recombinant Pro-Hv1a, Pro-Hv1a/GNA.

Figure 5.6 Survival of third instar larvae of *M. brassicae* following consumption of a single droplet containing recombinant protein.

Figure 5.7 Transport of Pro-Hv1a/GNA fusion protein from gut contents to haemolymph in larvae of cabbage moth (*Mamestra brassicae*).

Figure 5.8 Survival recorded of pea (*A. pisum*) (A), cereal (*S. avenae*) (B) and peach potato (*M. persicae*) (C) aphids fed on artificial diets containing 0.05-0.75 mg/ml of purified recombinant Pro-Hv1a, Pro-Hv1a/GNA,

Hv1a/GNA or GNA.

Chapter 6 Effect of insecticidal fusion proteins containing spider toxins targeting sodium and calcium ion channels on pyrethroid-resistant strains of peach-potato aphid (*Myzus persicae*)

Figure 6.1 Diagram of the *M. persicae* voltage-gated sodium channel showing the four main repeating homologous domains (I–IV).

Figure 6.2 Toxicity of fusion protein components towards *M. persicae*.

Figure 6.3 Survival data of P11a/GNA fusion protein towards *M. persicae*.

Figure 6.4 Survival data of Pro-Hv1a/GNA fusion protein towards *M. persicae*.

Chapter 7 General discussion and conclusions

Figure 7.1 Analysis of the market's trends of synthetic pesticides and bio-pesticides, with data for 2008, 2009 and 5-year compound annual growth rates through 2014 from BCC Research (Lehr, 2010).

Appendix

Appendix 1 Analysis of purified Cyrtautoxin (As1c) by 17.5% acrylamide SDS-PAGE gel (A) and western blotting (B).

Appendix 2 Quantification of purified As1c by 17.5% acrylamide SDS-PAGE gel.

Appendix 3 Survival recorded for fifth stadium larvae of *M. brassicae* following the injection of As1c toxin.

Appendix 4 Western blot (probed with anti-GNA antibodies) to show representative expression of Pro-Hv1a/GNA fusion protein in leaves of transformed *Arabidopsis thaliana* used for feeding bioassays..

Appendix 5 Characterization of purified recombinant Pro-Ec2a/GNA fusion protein by SDS-PAGE.

Appendix 6 Quantification of purified recombinant Pro-Ec2a/GNA fusion protein by 17.5% acrylamide SDS-PAGE gel.

Appendix 7 Survival of fifth stadium *M. brassicae* larvae following injection of different doses of Pro-Ec2a/GNA and Ec2a/GNA.

Appendix 8 Publication 1: A recombinant fusion protein containing a spider toxin specific for the insect voltage-gated sodium ion channel shows oral toxicity towards insects of different orders.

List of Figures

Publication 2: Effect of insecticidal fusion proteins containing spider toxins targeting sodium and calcium ion channels on pyrethroid-resistant strains of peach-potato aphid (*Myzus persicae*).

UK Patent: Pesticidal Fusion Protein Improvements. Applic. No. 1321938.1

List of Tables

Chapter 4 Recombinant spider toxin P11a, specific for the insect voltage-gated sodium ion channels, shows oral toxicity towards insects of different orders when fused to GNA

Table 4.1 Toxicity of Recombinant Toxins and Fusion Proteins in Injection

Bioassays with Lepidopteran (*Mamestra brassicae*) Larvae (P11a, Ao1bPro-P11a, P11a/GNA, Ao1bPro-P11a/GNA and Hv1aPro-P11a/GNA).

Table 4.2 Toxicity of Recombinant Toxins and Fusion Proteins in Oral Feeding

Bioassays with Lepidopteran Larvae (*Mamestra brassicae*).
Abbreviations as in Table 1.

Chapter 5 Addition of Pro-region to omega-atracotoxin (Hv1a) in a recombinant fusion protein with GNA (Pro-Hv1a/GNA) results in significantly enhanced insecticidal activity as compared to Hv1a/GNA

Table 5.1 Toxicity of Recombinant Toxins and Fusion Proteins in Injection

Bioassays with Lepidopteran (*Mamestra brassicae*) Larvae (Hv1a and Pro-Hv1a toxins; Hv1a/GNA and Pro-Hv1a/GNA fusion proteins).

Table 5.2 Toxicity of Recombinant Toxins and Fusion Proteins in Oral Feeding

Bioassays with Lepidopteran Larvae (*Mamestra brassicae*).
Abbreviations as in Table 1.

Chapter 6 Effect of insecticidal fusion proteins containing spider toxins targeting sodium and calcium ion channels on pyrethroid-resistant strains of peach-potato aphid (*Myzus persicae*)

Table 6.1 The LC₅₀ (9 days) for fusion proteins against *M. persicae* strains.

List of Abbreviations

Nucleic acid abbreviations:

A: Adenine

T: Thymine

G: Guanine

C: Cytosine

Amino acid abbreviations:

Amino acid	Single letter code	Three letter code	Name	Single letter code	Three letter code
Alanine	A	Ala	Isoleucine	I	Ile
Arginine	R	Arg	Leucine	L	Leu
Asparagine	N	Asn	Lysine	K	Lys
Aspartic acid	D	Asp	Methionine	M	Met
Cysteine	C	Cys	Phenylalanine	F	Phe
Glutamic acid	E	Glu	Proline	P	Pro
Glutamine	Q	Gln	Serine	S	Ser
Glycine	G	Gly	Threonine	T	Thr
Histidine	H	His	Tryptophan	W	Trp
Valine	V	Val	Tyrosine	Y	Tyr

Other abbreviations:

4106A: Wild type *Myzus persicae* strain

4824J: Pyrethroids-resistant *Myzus persicae* strain, which is homozygous for L1014F and M918T

794J: Pyrethroids-resistant *Myzus persicae* strain, which is homozygous for the mutation L1014F

Amaurobitoxin/GNA: P11a/GNA

ANOVA: Analysis of variance between groups

List of Abbreviations

Ao1b: U2-agatoxin-Ao1b toxin
AOX1: Alcohol oxidase 1
Approx.: Approximate
BB: Binding buffer
BCA: Bicinchonic acid
BK_{Ca}: Large conductance calcium activated potassium channels
BSA: Bovine Serum Albumin
ButaIT: Indian red scorpion (*Mesobuthus tamulus*) toxin
CBB: Coomassie brilliant blue
CNS: Central nervous system
Col-0: Columbia 0 ecotype (wild type) *Arabidopsis thaliana*
dATP: deoxyadenosine triphosphate
dCTP: deoxycytosine triphosphate
dGTP: deoxyguanine triphosphate
dNTPs: deoxyribonucleotide triphosphate
DTT: Dithiothreitol
dTTP: deoxythymine triphosphate
Ec2a: κ -theraphotoxin-Ec2a
ECL: Enhanced Chemiluminescence
ED₅₀: Amount of a toxin, which produces an effect on 50% of test animals
ER: Endoplasmic reticulum
FITC: Fluorescein Isothiocyanate
FP: Fusion Protein
FPLC: Fast Protein Liquid Chromatography
GAPDH: Glyceraldehyde 3-phosphate dehydrogenase
GM crops: Genetically modified crops
GNA: *Galanthus nivalis* agglutinin
GSP: Gene specific primer
GST: Glutathione- S-transferase
His-tag: Polyhistidine-tag
HRP: Horseradish Peroxidase
I–IV: Four repeating and homologous domains of NaChs
K_{Ca}: Calcium-activated potassium channels
kD / kDa: KiloDalton

List of Abbreviations

L1014F: *kdr* site mutation, a leucine-to-phenylalanine substitution

LB: Luria-Bertani broth

LC₅₀: Concentration of a toxin that causes the death of 50% of test animals

LD₅₀: Dose of a toxin that causes the death of 50% of test animals

LSLB: Low salt Luria-Bertani broth

M918L: *super-kdr* site mutation, an additional methionine-to-leucine substitution

M918T: *super-kdr* site mutation, an additional methionine-to-threonine substitution

NaChs: Voltage gated sodium channel

NMR: Nuclear magnetic resonance

N-X-S/T: N-glycosylation site

OD: Optical density

Omega/GNA: Hv1a/GNA

P83256: Mature P11a toxin

PBS: Phosphate buffered saline

PCR: Polymerase chain reaction

PD₅₀: Amount of a toxin, which produces an paralytic on 50% of test animals

PHA: Phytohaemagglutinin

PIs: Protease inhibitors

P11a: δ -Amaurobitoxin-P11a

Pro-Omega/GNA: Pro-Hv1a/GNA

RNAi: RNA interference

S1–S6: Six hydrophobic transmembrane segments of NaChs

SDS-PAGE: Sodium dodecyl sulphate polyacrylamide gel electrophoresis

SFI1: *Segestria florentina* toxin 1

SMD: *Pichia pastoris* strain

ST₅₀: Median survival time

TAE: Tris acetate EDTA buffer

TEMED: Tetramethylethylenediamine

UKO: Pyrethroids-resistant *Myzus persicae* strain, which is homozygous for the mutation M918L

V/V: Volume/Volume

W/V: Quality/Volume

ω -ACTX: ω -atracotoxin-Hv1a

List of Abbreviations

WCR: The western corn rootworm

YPG: Yeast peptone glucose media

Declaration and Statement of Copyright

Declaration

No material contained herein has been previously submitted for any other degree. Except where acknowledged, all material is the work of the author

Statement of Copyright

The copyright of the thesis rests with the author. No quotation from it should be published without prior written consent and information derived from it should be acknowledged.

Date:

Signed:.....

List of Publications

- (1) **Yang, S.**, Pyati, P., Fitches, E., Gatehouse, J.A. (2014) A recombinant fusion protein containing a spider toxin specific for the insect voltage-gated sodium ion channel shows oral toxicity towards insects of different orders. *Insect Biochem. Mol.* **47C:1-11**
- (2) **Yang, S.**, Gatehouse, J.A., Pyati, P., Fitches, E.C. (2013) Pesticidal Fusion Protein Improvements **International Patent. Applic. No. 1321938.1**
- (3) **Yang, S.**, Fitches, E. and Gatehouse, J.A. (2014) Effect of insecticidal fusion proteins containing spider toxins targeting sodium and calcium ion channels on pyrethroid-resistant strains of peach-potato aphid (*Myzus persicae*). *Pest Manag Sci* doi: 10.1002/ps.3872

Acknowledgements

I would like to thank Prof. John Gatehouse (School of Biological and Biomedical Sciences, Durham University) for his supervision, support and guidance during my PhD study. A special thanks goes to Dr. Elaine Fitches (FERA, York) for her support and patience throughout the project as well as revising one of my papers. Thanks also to Dr. Prashant Pyati for his inculcating in my protein expression work and some other guidance. I am also very grateful for the funding provided by Durham University joint with China Scholarship Council.

Alongside John, Elaine and Prashant, I also acknowledge the other members of lab 1 (past and present) for their valuable help. Particular thanks extended to Dr. Dominic Wood and Miss Min Cao for their advice on my experiments.

My appreciation is also extended to Prof. Linda M Field (Department of Biological Chemistry and Crop Protection, Rothamsted Research, UK), who kindly provided the mutant strains of peach-potato aphid, *Myzus persicae* (Sulzer) (Hemiptera: Aphididae), to me for helping me finish a part of my PhD program. Also, thanks to Dr. Cunjin Zhang for help with plant transformation techniques and Mr. Erich Tempel Nakasu for supplying me the figures of the effect of P11a/GNA on honey bees.

I am indebted to my parents who have always given me support, encouragement and love throughout all my studies. My heartfelt thanks are also given to my best friends who have made my life in UK unforgettable.

Sheng Yang

CHAPTER 1 INTRODUCTION

1.1 Insects as crop pests

1.1.1 Crop pests

Arthropods represent the largest animal phylum, containing an estimated 4-6 million species. However, only a small percentage of arthropods cause damage to crops and these species are considered to be plant pests (Novotny et al., 2002). Most crops suffer productivity losses due to competition from animal pests, weeds, bacteria and viruses. Of these, insects are the major enemies of crops. They can cause two different kinds of damage to growing crops. Direct damage by eating leaves, buds, fruit and roots or by feeding on juice from cultivated plants is caused by pest species including larvae and adults of the orders of Orthoptera, Homoptera, Heteroptera, Coleoptera, Lepidoptera and Hemiptera (Matthews, 1999). Indirect damage comes from insects, which may cause little or no harm to crops but can transmit a bacterial, viral, or fungal infection. For example, aphids can transmit viral diseases in some crops including sugar beet and potatoes (Kennedy and Collier 2000; Eleftherianos et al., 2008). Without the use of pesticides insect pests can cause irreversible damage to the production of the crops. However, the use of pesticides has an economic impact upon the cost of crop production. For example, in 2001, an estimated US\$7.56 billion was spent on the control of invertebrate phytophagous pest species (Beckmann and Haack, 2003; Nicholson, 2007).

Species from the order Lepidoptera are the most destructive insect pests, affecting major global crops such as soybeans, tomatoes, sugar cane and maize, as well as lettuce, onion, potato, pea, etc. (Heath and Emmet, 1979; Carter, 1984). Many Lepidopteran pests are polyphagous, and affect a range of crops. For example, larvae of the Lepidopteran *Mamestra brassicae* (cabbage moth) (*M. brassicae*) are able to feed on at least 70 species of plants, although the favorite foods for them are species from the Brassicaceae and Chenopodiaceae (Popova, 1993). The annual cost of *M. brassicae* control globally is approx. U.S. \$1 billion (Talekar, 1992). A minority of Lepidopteran pests are monophagous, such as rice stem borers (*Scirpophaga* sp.).

Hemipteran insects such as aphids and hoppers are destructive sap-sucking pests

that feed on cultivated plants. There are approx. 5000 aphid species living on crops; examples of species that cause significant damage are cereal aphid (*Sitobion avenae* F.), pea aphid (*Acyrtosiphon pisum*) and peach-potato aphid (*Myzus persicae*). In addition to direct damage caused by feeding they also cause indirect damage through their ability to transmit viral diseases, for example, peach-potato aphids, due to their ability to transmit virus diseases, can cause serious damage to agricultural and horticultural crops (McCaffery and Nauen, 2006; Eleftherianos et al., 2008). However, the reason they are hard to control is due to their ability to reproduce at a rapid rate. The life cycle of aphids is rapid with a complete generation taking just 10-12 days (Emden et al., 1969). On average, the daily rate of reproduction is 1.6 nymphs per female, depending on the genotype and environment (Blackman, 1974). The cost of aphid control is estimated to be billions of dollars each year (Blackman and Eastop, 1984; Oerke, 1994; Morrison and Peairs, 1998).

Dipteran crop insects such as cabbage root fly (*Delia radicum*), carrot fly (*Psila rosae*) and hessian fly (*Mayetiola destructor*) are destructive pests in horticulture, cereals and home gardens. The larvae of cabbage root fly feed on roots of cabbages and other brassicas, and cause damage by tunnelling into the roots of swedes, turnips and radish (Gratwick, 1992). Similarly, larvae of carrot fly feed on the roots of carrots and related plants, such as parsnip, parsley, celery and celeriac. They can also penetrate further into the root of carrots and cause serious decay (Collin, 1944; Christopher, 1996). Hessian fly is a worldwide destructive pest of cereal crops including wheat, barely and rye (Makni et al., 2011). It is very harmful as it attacks the stem of crops, even other parts of cereal if it is starving. In 1836, a quite serious infestation of hessian flies led to a crop shortage worsening the financial problems of farmers ahead of the panic of 1837 in North America (McGrane, 1924). Dipteran crop insects can be difficult to control due to the absence of effective chemical pesticides which can be delivered effectively to feeding sites, and alternative strategies, such as the use of biological pest control to combat hessian fly have been used.

Coleopterans (beetles and weevils) are the largest insect order with beetles accounting for an estimated 40% of all insect species (Hammond, 1992; Rosenzweig, 1995). Beetles feed on a wide range of plants and can cause significant reduction in crop yields. The western corn rootworm (WCR), *Diabrotica virgifera virgifera* LeConte (Coleoptera: Chrysomelidae), is a major pest of cultivated corn, *Zea mays* L.

The larvae can cause enormous damage to the corn plant by feeding on the root of plant (Levine et al., 2002). In the early nineties in Serbia, WCR was first found in Europe and then the beetles spread into 15 European countries (Ciosi et al., 2008). Therefore, controlling further spread of WCR was necessary because doing this could protect maize from destruction by the beetles and avoid large economic losses. The population of WCR in one country was controlled would benefit the corn plant in other neighbouring countries with the average annual economic benefits of 472 million Euro. This was because reduction of the WCR's population in one country reduced the speed of spread of the WCR to other regions (Wessler and Fall, 2010). Another beetle, Colorado potato beetle, *Leptinotarsa decemlineata* (Say) (Coleoptera: Chrysomelidae) is the most destructive insect pest of potatoes by feeding on the whole potato crops. Currently, it has spread into North America, Europe, and Asia and continues to expand (Weber, 2003). It is difficult to manage the population of Colorado potato beetles due to their complicated and diverse life history and ability to develop insecticide resistance (Alyokhin, 2009). The only sustainable method to protect potato crops is to integrate multiple control techniques into a scientific management approach (Alyokhin, 2009). The flour beetle, *Tribolium castaneum* is also a destructive pest of stored agricultural products including cereals, flour, bean, spices, pasta, and many other products (Richards et al., 2008; Nowaczyk et al., 2009). It leads to large economic losses via the contamination of stored food, which lowers the nutritive value of stored food (Nowaczyk et al., 2009). It is estimated that economic losses caused by stored-product pests vary from 1.25 to 2.5 billion dollars annually in the United States (Flinn et al., 2007).

In addition, insects within the orders Acarina, Orthoptera and Thysanoptera, are also considered to be agricultural pests as they also feed on crop plants. At first, the carmine spider mite *Tetranychus cinnabarinus* (Boisduval) (Acarina: Tetranychidae) belong to the major pest of greenhouse plants such as beans, cucumber, eggplants, pepper, strawberries and cotton in the Mediterranean region of Turkey (Bulut et al., 2000; Dağlı and Tunç, 2001). Their high reproductive potential and short life cycle lead to even more rapid resistance to numerous miticides (Ambikadevi and Samarjit, 1997). The mite pests have developed up to 100-fold resistance to dicofol and over 460-fold to parathion (Dağlı and Tunç, 2001). Therefore, the effects of many miticides on the mite pests have been reduced and the cost of chemical control has increased a lot (Sertkaya et al., 2010). Moreover, the most conspicuous of all insect

pests locusts and grasshoppers (Orthoptera: Acrididae), which are abundant insects of dry grassland and desert, also increase the cost to control them (Lomer et al., 2001). The chilli thrips, *Scirtothrips dorsalis* Hood (Thysanoptera: Thripidae) originally from south Asia, which is also a significant pest of various vegetable tropical fruit and ornamental crops, is now becoming widely distributed in tropical, subtropical and temperate areas (Seal et al., 2006).

In summary, in farmers' field, using conventional pesticides to suppress the population of insect pests is still likely to be the predominant approach. Conventional pesticides such as DDT and its analogues, pyrethroids, N-alkylamides, and dihydropyrazoles, which affect channel gating and ion permeability, are hydrophobic compounds, and are able to cause paralysis in insects via preventing closure of the insect ion channel (Zlotkin, 1999). They are quite effective against some target insect pests such as aphids. But for other pests like beetles, most of the conventional pesticides do not work. Therefore, exploitation of other approaches against insect pests is necessary. One method is used to control insect pests via common cultural practices or natural enemies. A large number of species including predatory insects and entomopathogens are employed as agents of biological control to kill insect pests due to their high efficacy, harmless to humans and other non-target organisms (Lacey et al., 2001). For example, this method is carried out by the introduction of various predatory insects or mites, parasitic wasps, nematodes that are able to eat hessian fly directly or infect hessian fly with a fatal bacterial disease (Finch, 1993; Andreassen et al., 2009). Moreover, biological control can also lead to reduction in conventional pesticide use and increase the biodiversity in managed ecosystems (Lacey et al., 2001). However, in consideration of the commercial use, biological control has some disadvantages. For example, firstly, it is often unpredictable and will not exterminate the pest. Secondly, culturing them is difficult and expensive. Thirdly, the interrelationship between biological control and insect pest is complex. Finally, the results against insect pests are slow to achieve. Hence, it is necessary to operate biological control agents carefully in case they disrupt food chains and to keep populations of agents under control in case the target insect pest builds up resistance (Butt et al., 2001). Another method is used to control the population of pests such as beetles, aphids and other pests via molecular biology such as double strand RNA to trigger RNA interference and insecticidal fusion

protein technology to paralyse the nervous system (Baum et al., 2007; Alyokhin, 2009).

1.1.2 Insect pests towards Humans

The Dipteran insect, housefly (*Musca domestica*) mainly lives around human beings and feeds on food, food residues and human waste. It can contaminate the human food and affect the human life and is able to carry over 100 human pathogens. Another Dipteran insect, the house mosquito (*Culex pipiens*) living on sucking the blood of humans or animals can transmit serious diseases such as malaria, dengue–dengue hemorrhagic fever, yellow fever, filariasis, Japanese encephalitis, Rift Valley fever and West Nile virus (Gratz, 1999; Gubler, 2002; Mackenzie et al., 2004). These diseases infect around 3 billion people or 46% of the world's population. African people are the most affected by diseases like malaria largely due to climate and poor sanitation. The World Health Organisation (WHO) estimated that the African region suffered 627 000 deaths in 2012 (Breman, 2001; Nicholson, 2007).

1.2 Agriculture and insect pests

At present, the human population is growing at a rate of around 90 million per year and is expected to reach approximately 10.1 billion in 2100 (Bloom, 2011). This means that there is an urgent need to produce larger amounts of food. However, plant diseases and insect pests lead to significant reductions in crop yield. According to data supplied by The Global Crop Diversity Trust, around 30-40% of the world's crop produce is lost by pests and associated crop diseases (Garthwaite et al., 2008). Yield reductions attributed to insect damage have been valued at approx. US\$100 billion each year (Carlini and Grossi-de-Sa, 2002). Take the UK as an example, every year, more than 370 tonnes of insecticides are applied to kill crop pests at a cost more than £25 million (Garthwaite et al., 2008). The indiscriminate use of synthetic pesticides for crop protection has resulted in widespread concerns due to negative effects on the evolutionary selection of pests, poisonous effects on microorganism and beneficial insects and higher animals. Moreover, the development of resistance to pesticides by target pests provides significant challenges to the sustainable reproduction of crop and conventional agriculture. Environmental concerns have resulted in the withdrawal of many older, broad-

spectrum pesticides from use (Denholm and Rowland, 1992; Casida and Quistad, 1998; Desneux et al., 2007). A reduction in the number of pesticides approved for use has resulted in increased incidences of resistance. Now, more than 600 insects and mites including peach-potato aphids (*Myzus persicae*) (Sulzer) (Hemiptera: Aphididae), housefly (*Musca domestica*) etc., and many key disease vectors, are resistant to one or more classes of chemical insecticides (Scott et al., 2000; Eleftherianos et al., 2008; Yang et al., 2014b)

1.3 Hazards of pesticides to human beings and environment

Exposure to pesticides, either directly during application to crops, or indirectly such as through the consumption of unwashed vegetables or fruit, can result in damaging effects on human health (U.S. Environmental Protection Agency, 2007). For example, simple symptoms caused by pesticides include irritation of the skin, eyes, nose and throat. More serious effects include damage to the nervous system, reproductive problems, via mimicking of pesticides to human hormones, and even cancer (Whorton et al., 1977). Around 3 million workers in agriculture in the developing world suffer serious poisoning from pesticides annually and about 18,000 people die as a result of pesticide exposure, as reported by the WHO and the UN Environment Programme (Miller, 2004). At the same time, each year 25 million workers in developing countries are thought to suffer mild pesticide poisoning (Jeyaratnam, 1990).

The indiscriminate use of pesticides causes many environmental problems. Widespread applications over the years have resulted in many pesticides losing their effectiveness, due to the development of resistance in target pests (Whalon et al., 2003). Moreover, high application rates can cause the destruction of non-target, beneficial insects (Flexner et al., 1986; Desneux et al., 2007). The excessive use of pesticides has also led to detrimental environmental impacts through the pollution of air, water and soil (Miller, 2004). High levels of pesticide use can cause ground water pollution, through soil contamination, run-off, leaching and wind (Wilson and Tisdell, 2001) (Fig. 1.1). Fish yields can be also seriously affected because many pesticides are highly toxic to fish even at normal rates of field application (Grist, 1986). In aquatic systems, high concentrations of pesticides in water kill the fish directly. Indirectly, low-levels of pesticide may kill essential fish foods such as

insects and other invertebrates. Pesticides in water can destroy micro-plants leading to reductions in dissolved oxygen levels and this can also cause fish mortality (Wilson and Tisdell, 2001). High levels of soil pesticides can also reduce symbiotic nitrogen fixation, which occurs in plants that harbour nitrogen-fixing bacteria within their tissue (Rockets, 2007). Pesticides could also affect or do harm to pollinators, since insects form the majority of biotic agents (vector) which move pollen from the male anthers of a flower to the female stigma of a flower to accomplish fertilization (Haefeker and Erwerbsimkerbund, 2000; Hackenberg, 2007). For example, although neonicotinoid insecticides are effective on a lot of crop pests, they are also detrimental to non-target pollinators like bees including honeybees, bumble bees and solitary bees (Blacquiere et al., 2012). Therefore, The EU bans the use of neonicotinoids in flowering crops that will be pollinated by bees (Gross, 2013). Overall, the result of indiscriminate use of non-specific pesticides can cause serious damage to ecosystems (Miller, 2004).

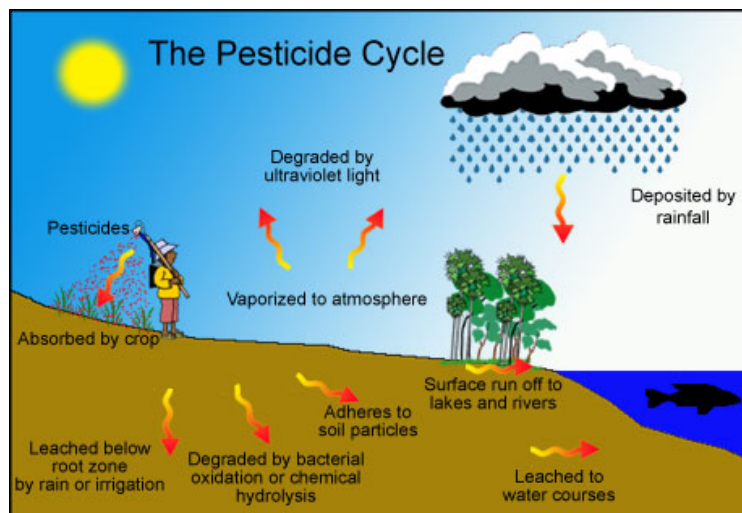

Figure 1.1

The pesticide cycle in the environment when absorbed by crop plants. It shows that pesticides have detrimental effects on the ground water and soil. The figure is from the website named the Organic Farming Blog.

1.4 Environmentally compatible technology of pest control: insecticidal peptide proteins from spider in fusion with "carrier", "vector" or "coat" proteins as novel bio-insecticides

Due to the rapid development of genetic engineering technology, production of a range of environmentally compatible bio-pesticides has developed into a technology with the potential to achieve effective control of pests and commercial exploitation, complementing and possibly replacing existing chemical pesticides. The so-called biological pesticides (bio-pesticides) are certain types of pesticides derived from natural materials including microorganisms such as viruses, fungi and bacteria; entomophagous nematodes; plant defensive proteins; insect pheromones and insecticidal toxins derived from insect predators and parasitoids; pest resistance genes in crops (Quistad and Skinner, 1994; Tomalski et al., 1988; Copping and Menn, 2000; Froy et al., 2000; King et al., 2007; Nicholson, 2007; Windley et al., 2012). The present thesis focuses on bio-pesticides derived from components of spider venoms, which contain many insecticidal neurotoxic peptides. Protein/peptide toxins from spiders combine efficacy with specificity and are biodegradable, making them more environmentally compatible than some chemical pesticides, which are resistant to degradation.

Protein-based bio-pesticides have an additional advantage in that they can be produced in genetically modified (GM) crops by transfer of gene constructs into plants using *Agrobacterium tumefaciens* as a vector, or other methods such as direct DNA uptake. For example, GM crops expressing microbial toxins from *Bacillus thuringiensis* have made a valuable contribution to agriculture and have come to be seen as an environmentally benign form of pest control.

1.4.1. Neurotoxins from spider venoms as one of the components of insecticidal fusion proteins

1.4.1.(i) Peptide proteins from spider venoms

Spiders preying on invertebrates, mainly insects and other arthropods, are polyphagous (Kuhn-Nentwig et al., 2011). The peptides involved in the venoms of spiders compose of a series of compounds, which target different kinds of insects.

Few venoms of spiders are toxic to human beings, although some bigger spiders prey on some small vertebrates, including mammals (Isbister and White, 2004; Isbister and Fan, 2011). Spider venoms typically cause flaccid paralysis, so the spider can catch, kill and eat its prey.

The typical spider venom toxin is a small protein, or large peptide (both terms are used interchangeably) consisting of 30-40 amino acids, which targets an insect ion channel. They are termed neurotoxins due to their effects on neurones. The toxins have a compact structure, containing multiple intrachain disulphide bonds between pairs of cysteine residues. A single spider usually has multiple toxins present in its venom; at least 100 different toxins have been observed in some species (King and Hardy, 2013). These peptides are able to destroy the modulation of glutamate receptors, transient receptor potential channels, and affect pest nerve ion channels such as calcium-activated potassium channels, voltage-gated calcium, sodium, and potassium channels. The results of toxin interaction with channels or receptors give rise to numbing of the nervous system of the insect leading to flaccid paralysis, or causing hyperexcitability of the nerve system leading to convulsions and paralysis (King and Hardy, 2013; Ikonopoulou and King, 2013).

Up to now, more than 200 cysteine-rich insecticidal peptides from spiders have been sequenced. Their size ranges from 3.3kDa to 9.0kDa, containing 3-6 disulfide bonds (Maggio et al., 2010; Windley et al., 2012). Comparatively few toxins have been purified in amounts sufficient for assays, but many of those that have been assessed are highly selective for insects, and showed no toxicity to mammals (King and Hardy, 2013). Structural studies have led to an understanding why the peptide toxins of spiders can effect on the ion channels of pest and kill them. These small proteins have a specific three-dimensional structure known as inhibitor cysteine knot. The mechanism of formation of this structure is divided into two steps. Firstly, two disulfide bridges form a “ring” structure. Secondly, the third disulfide bond pierces the intervening sections of peptide backbone to make a “pseudo-knot” (Fig. 1.2) (King and Hardy, 2013). This compact structure confers physical stability on toxins, which are stable to harsh solvents, extremes of temperature and pH. More importantly, this “inhibitor cysteine knot” structure affords these peptides resistance to proteolytic enzymes from the prey (Saez et al., 2010). Therefore, the potency and selective mode of action of spider neurotoxins would make them ideal candidates for

use in environmentally compatible pest management technologies, if a suitable delivery system could be devised (Whetstone and Hammock, 2007). In general, these toxins are not effective as oral or contact insecticides, and no system that requires injection could possibly be feasible in the field.



Figure 1.2

The spider toxin Amaurobitoxin-PI1a, Uniprot P83256 (PI1a) structure PDB1V90. The toxin recognizes insect voltage-gated sodium channels by a β -sheet secondary structure (the three big yellow arrows in the figure), loops I, IV of the toxin and the specific dipolar moment orientation (Ferrat et al., 2005).

1.4.1.(ii). Insecticidal venom peptide synthesis: the role of a predicted Pro-region

In nature many venom peptides, including those from snakes, sea anemones, marine cone snails, scorpions and spiders are translated as precursors that undergo post-translational modification to yield a mature toxin (Sollod et al., 2005). The precursors all contain a co-translationally removed N-terminal signal peptide that directs the transcript into the ER to ensure correct folding and thence to a specific secretory pathway (Sollod et al., 2005). The Pro-region is a region C-terminal to the signal peptide and N-terminal to the mature sequence that is removed during or after the secretory process. It is a component of many protein and peptide sequences, including proteases, growth factors, neuropeptides, and polypeptide hormones, and is often used to prevent the protein showing full biological activity until it is appropriate, as is the case with digestive proteases. Pro-regions are also present in cone snail and sea anemone venoms but generally absent in scorpion and snake toxin precursors (Pineda et al., 2012). In spiders “short” (< 5 kDa) venom peptides, like the ω -hexatoxin-Hv1a (Hv1a) toxin, typically contain acidic propeptide regions whereas transcripts encoding longer toxins do not (Tedford et al., 2004b, Wang et al., 2001, Chen et al., 2008). Despite the abundant presence of Pro-regions in venom precursors, the specific role(s) of the Pro-region remain to be understood.

The role of Pro-regions in directing the correct *in vivo* folding of proteases is well established (Eder and Ferscht, 1995). For example, Pro-regions can help protease inhibitors (PIs) or *E.coli* heat-stable enterotoxin fold correctly with maturation and can also help secretion of *Streptomyces hygroscopicus* transglutaminase (Baker et al., 1992, 1993; Yamanaka et al., 1993; Liu et al., 2011). The single cysteine of the bovine pancreatic trypsin inhibitor (BPTI) Pro-region strikingly increases the proportion of folding by serving as an intramolecular disulfide reagent and promoting the formation of the proper disulfide bonds (Weissman and Kim, 1992). Proconvertase-dependent cleavage of promyeloperoxidase was an essential step in normal proteolytic processing (McCormick et al. 2012). Similarly, cleavage of Pro-region of E-cadherin was essential for E-cadherin maturation (Geng et al., 2012) and the removal of the Pro-region can mature Neurotrophins and confer them activities (Lu, 2003). A similar role in directing correct folding in members of the cysteine knot family has been demonstrated. For example, the Pro-region of nerve growth factor has been shown to

be essential for the correct folding of the cysteine knot domain (Rattenholl et al., 2001). Similarly, Hoffmann et al., (2008) suggested that the Pro-region in the *Drosophila* Spätzle cysteine knot protein, played an important role in stabilising the tertiary structure of the mature protein. Given the abundance of proteins and peptides that are processed from Pro-region containing precursors it is likely that Pro-regions play a diversity of roles. The importance of the conserved nature of Pro-regions in venom toxin transcripts encoding hypervariable mature toxin sequences was recognised as early as 1990. Woodward et al., (1990) in a study of the King-Kong family of conotoxins suggested that Pro-regions were thought to be functional to enhance toxin folding and/or provide signals for post-translational modifications such as C-terminal amidation. Chemical synthesis of cysteine rich short venom peptides results in the formation of a number of disulphide bonded configurations whereas only the “natural” conformation shows high affinity for the receptor target providing further evidence of the requirement for precise molecular control of the folding of small peptides. From the physical theory analysis, the mechanism that Pro-regions may improve protein folding is via the supply of a source of energy that may act to lower transiently the height of the energy barrier that proteins need to overcome to maintain stability during folding (Baker et al. 1993).

Inclusion of Pro-regions may be necessary to ensure that recombinant toxin proteins expressed in microbial expression systems retain biological activity. For example, when the DNA sequence of conotoxin TxVIA (also known as δ -TxIA and KingKong peptide) gene was analysed, the encoding gene was found to include two sequences that are not present in the final protein product; a predicted N-terminal signal peptide that is removed during translation and a predicted Pro-region, between the signal peptide and the final sequence of the protein as isolated (Bruce et al., 2011). TxVIA belongs to disulphide-rich delta conotoxin of the O1 superfamily, which contains 27 amino acids and six cysteine residues to form disulphide bridges I–IV, II–V and III–VI (Terlau et al., 1996). Inclusion of this predicted Pro-region in a construct for expression of a recombinant toxin in the yeast *Pichia pastoris* resulted greater biological activity compared to a toxin produced from a construct lacking a Pro-region (Bruce et al., 2011).

1.4.2. “Carrier”, “vector” or “coat” protein as another component of insecticidal fusion proteins

The lack of oral toxicity of many protein toxins that could be used as bio-pesticides has prevented their exploitation in crop protection. Several different approaches have been suggested to overcome this problem, including formulations to improve protein penetration into the insect, and delivery systems based on insect viruses. However, the approach followed in this thesis is the fusion protein strategy, as developed by the Durham and Fera labs, in which the toxin is combined with a “carrier” protein.

1.4.2.1. Snowdrop lectin acting as a “carrier” domain in spider fusion proteins

1.4.2.1.(i) Snowdrop lectin (*Galanthus nivalis agglutinin*; GNA)

Bio-pesticides used for crop protection against insect pests generally function via oral delivery, with the toxin proteins present in, or sprayed on the plant tissues susceptible to damage (Fitches et al., 2012). The use of a "carrier" in recombinant fusion proteins leads to transport of toxin proteins from the gut contents across the insect gut epithelium to the central nervous system where the toxin is active, resulting in dramatically enhanced oral insecticidal activity (Fitches et al., 2002).

The mannose-specific lectin from snowdrop (*Galanthus nivalis agglutinin*: GNA) (Van Damme et al., 1987) has proved successful as a carrier. The protein has a tetrameric structure, where each subunit of 109 aa contains three potential carbohydrate binding sites (Fig. 1.3). Mature GNA is formed when a C-terminal peptide is cleaved during post-translational processing. Mature GNA is highly resistant to proteolytic activity in the insect gut, and specifically binds to terminal mannose residues of gut epithelial glycoproteins (carbohydrate binding ability), leading to transport into the haemolymph of pest following ingestion (Fitches et al., 2001). GNA is transported across cells in the gut epithelium by endocytosis. Fitches et al (2001) states this involves " a transport process by which lectin bound to the surface of the cell adjacent to the gut lumen was internalised, and moved across the cell to the surface opposite the gut lumen, from which it could potentially be released into the haemolymph." For example, the insect ferritin subunits, which are present in many tissues of insects, including midgut, haemolymph, Malpighian tubules and fat body, are normally abundant as the binding protein for GNA and play pivotal roles in the intake, transport and excretion of iron (Du et al., 2000). They are known to act as a form of glycosylated protein and are released into the gut lumen to function in

iron transport in insects (Locke and Nichol, 1992). In addition, the binding affinity between the ferritins and GNA is low. Therefore, the ferritin can release GNA into the haemolymph after transfer across the midgut of insect (Locke and Nichol, 1992; Du et al., 2000). Taking ferritins in the rice brown plant hopper (*Nilaparvata lugens*) as an example, GNA can cause an insecticidal effect on *N. lugens* by means of binding to a 26kDa subunit of a ferritin-like glycoprotein from the midgut of *N. lugens*, which is able to release GNA into the haemolymph (Powell et al., 1998; Du et al., 2000).

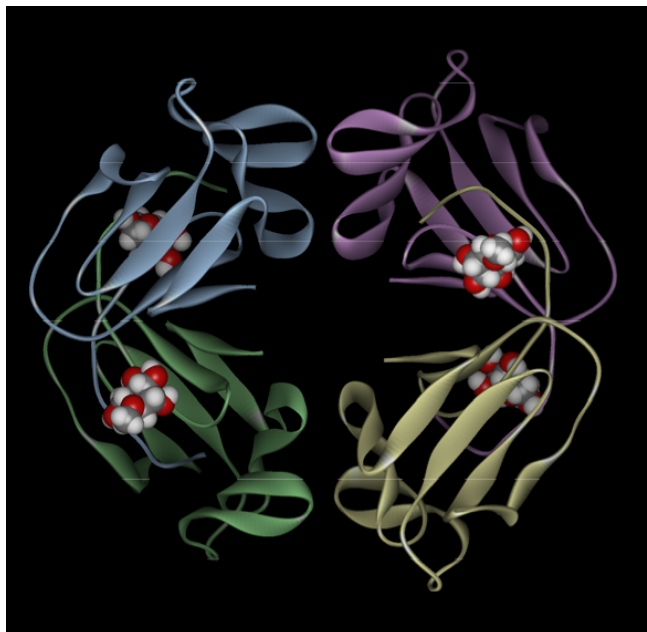

Figure 1.3

GNA PDB structure. Four subunits of protein are distinguished by ribbon colouring, and the high-affinity carbohydrate binding site on each subunit contains a bound sugar molecule (space-filling models).

GNA has been shown to be insecticidal to several crop insect pests, especially Hemipteran insects (Powell et al., 1993; Hilder et al., 1995; Rahbe' et al., 1995; Sauvion et al., 1996; Down et al., 1996; Gatehouse et al., 1996, 1997; Rao et al., 1998; Stoger et al., 1999; Fitches et al., 2001, 2012; Yang et al., 2014a, b). A dose-dependent effect of GNA on honeydew production of *N. lugens* was demonstrated after feeding GNA to the insects at doses between 0.01 and 0.1% (w/v) (Powell et al., 1995). GNA showed increased mortality and a negative effect on weight gain of *N. lugens*. The similar results of GNA on peach-potato aphids (*Myzus persicae*) were also reported by Sauvion et al., (1996) and Down et al., (2000) who both indicated that GNA significantly affected the growth of *M. persicae* and caused mortality of aphids. Moreover, the accumulation of GNA in aphids also suggested that GNA are able to bind to the gut epithelium within Homopteran species. In addition, expression of GNA in transgenic crop plants also affected the growth and weight of insect pests after ingestion of the diets containing the transgenic plant materials. For example, tomato moth (*Lacanobia oleracea*) showed decreased gains in biomass and longer instar durations when fed on artificial diets containing GNA or transgenic plants by expression of GNA (Fitches et al., 1997). Similarly, expression of GNA in transgenic rice plants also showed resistance to *Nephotettix virescens* and *N. lugens* (Foissac et al., 2000; Nagadhara et al., 2003). GNA-expressing rice plants significantly affected the survival of nymphs (more than 50%). Moreover, honeydew production was less on the GNA-expressing plants (Foissac et al., 2000) and less plant damage on the transgenic plants was recorded than non-transgenic rice plants (Nagadhara et al., 2003). In addition Nagadhara et al., (2004) demonstrated in feeding assays that the expression of GNA specifically in the phloem of transgenic rice plants showed high resistance (survival of nymphs and fecundity of adults both decreased by 90% as measured by the production of honeydew) against *Sogatella furcifera*. GNA was detected in total insect extracts. As reported, GNA also showed negative effects on other pest species. Nymph production of corn leaf aphids (*Rhopalosiphum maidis*) decreased after feeding on corn plants strongly and constitutively expressing GNA (Wang et al., 2005). Moreover, expression of GNA in transgenic sugar cane plant showed significantly resistant to Lepidopteran stalk borers, *Eorreuma loftini* and *Diatraea saccharalis*. Decrease in female fecundity was both observed in these two species (Se'tamou et al., 2002).

1.4.2.1.(ii) Fusion of spider neurotoxins to GNA as recombinant fusion proteins

The lack of insecticidal effects seen after oral delivery of spider neurotoxins has been ascribed to poor absorption by insects and degradation by proteinases in the gut, although a number of purified neurotoxins have been proved to be highly insecticidal by injection (Quistad et al., 1991; Fitches et al., 2004). GNA alone has been shown to have insecticidal effects on some insects, although with others only marginal effects were observed, e.g. when purified GNA was fed to cabbage moth larvae (Fitches et al., 2001, 2004 and 2012).

Although neither GNA nor the toxin alone was insecticidal when fed to insects, fusion protein technology, which is based on expression of GNA as a recombinant protein in a fusion with a spider protein toxin, can solve this problem properly. The carbohydrate binding activity of GNA mediates transport of fusion proteins from the gut contents across the insect gut epithelium to the central nervous system (CNS) where the toxin is active, resulting in dramatically enhanced oral insecticidal activity (Fitches et al., 2002). For instance, a toxin protein from the spider *Segestria florentia* toxin 1 (SF11) was delivered to the haemolymph of Lepidopteran larvae after oral delivery by fusing to GNA, causing decreased survival and growth in insects fed on diet containing the fusion protein (Fitches et al., 2004). Like their component proteins, fusion proteins are susceptible to digestion by gut enzymes of pests, but their high toxicity due to the toxin component of the fusion means that enough active protein can be delivered to be effective. For another example, the ω -hexatoxin-Hv1a (Hv1a) toxin protein from the funnel-web spider *Hadroncybe versuta*, was delivered to the haemolymph of *M. brassicae* larvae after oral delivery by fusing to GNA, giving rise to mortality and retarded growth of insects (Fitches et al., 2012). Furthermore, Fitches et al., (2012) also demonstrated that the Hv1a/GNA was present in the insect haemolymph and CNS. The carbohydrate-binding activity of GNA also enables it to act as an anchor to bind toxin to nerve tissue and increase its local concentration, leading to a higher effective dose. Evidence from western blotting showed high levels of both GNA and fusion protein associated with nerve chord tissue after injection into cabbage moth larvae, supporting the role of GNA as an "anchor" to localise toxin on nerve tissue (Fitches et al., 2012). Fusion to GNA could also improve toxin folding during production as a recombinant protein, leading to a product with more biological activity. Take Hv1a and Hv1a/GNA fusion protein

as examples; Hv1a/GNA fusion protein (0.1-0.2% w/v) caused more than 80% mortality when injected into second stadium *M. brassicae* larvae when compared to Hv1a toxin alone (Fitches et al., 2012).

1.4.2.1.(iii) Vector constructs of recombinant fusion proteins

A recombinant vector expression system was used to produce recombinant fusion proteins. Two kinds of fusion proteins could be generated by fusing the N-terminus of neurotoxins to the C-terminus of GNA or by fusing the C-terminus of neurotoxins to the N-terminus of GNA (GNA/toxin or toxin/GNA). For GNA, biological activity (carbohydrate binding) is retained whether toxins are fused to the N-terminus or C-terminus. In contrast, the N-terminus or C-terminus of insecticidal peptides and proteins can be important for biological activity, and constructs have to be designed to maximise biological activity of the toxic component. Therefore, for example, GNA was fused to the N-terminus of the insect hormone *Manduca sexta* allatostatin (Manse-AS) to generate GNA/Manse-AS fusion protein. The product retained the biological activity of the peptide, shown by reducing the growth of fifth stadium *Lacanobia oleracea* (*L. oleracea*) larvae when administered orally as a component of artificial diet (Fitches et al., 2002). The C-terminus of the Manse-AS is known to be vital for biological activity, and thus could not be altered in the fusion. In contrast, when the recombinant toxins were joined its C-terminus to the N-terminus of GNA and was incorporated into the toxin /GNA fusion proteins, these fusion proteins could show both injection and ingestion activities. For example, according to the injection results of spider fusion protein SF11/GNA and the scorpion fusion protein ButaIT/GNA (the scorpion neurotoxin ButaIT from *Mesobuthus tamulus*) towards larvae of the tomato moth *L. oleracea* and the cotton leafworm *Spodoptera littoralis* (*S. littoralis*), respectively, SF11/GNA was more insecticidal than ButaIT/GNA to *L. oleracea* (Fitches et al., 2002; Trung et al., 2006); In contrast, ButaIT/GNA was more toxic than SF11/GNA to *S. littoralis* (Fitches et al., 2010). In addition, ButaIT/GNA was more toxic than SF11/GNA against a range of insect pests (Fitches et al., 2010). Furthermore, the fusion protein containing GNA attached to the N-terminus of the toxin ButaIT (GNA/ButaIT) also showed insecticidal activity towards Coleopteran and Homopteran insects (Back, Ph.D. thesis; unpublished data), which implied that the C-terminus and N-terminus of ButaIT toxin are known to be not vital for its activity.

1.4.2.1.(iv) Toxin from the Australian funnel web spider (*Hadronyche versuta*) and its use in fusion to GNA

ω -atracotoxin-Hv1a (Hv1a) toxin is a member of a family of insecticidal neurotoxins, which possess 36–37 residues, from the Australian funnel web spider *Hadronyche versuta* (Tedford et al., 2001) (Fig. 1.4). Hv1a arrests insect voltage-gated calcium channels and has no negative effects to mammals (Fletcher et al., 1997; Tedford et al., 2004a; Chong et al., 2007). The three-dimensional structure of Hv1a has been determined by NMR in solution (Fletcher et al., 1997). Hv1a has no alpha-helix structure but contains around 24% beta-sheet, 76% loop (coil) and three disulphide bonds (bond 4-18, 11-22, 17-36) for its secondary structure. Importantly, the three disulfide bonds form an inhibitor cysteine knot motif, which confers chemical and thermal stability and resistance to proteases (King et al., 2002; Saez et al., 2010). The highly conserved C-terminal β -hairpin of Hv1a contains the key residues for insecticidal activity (Tedford et al., 2001).

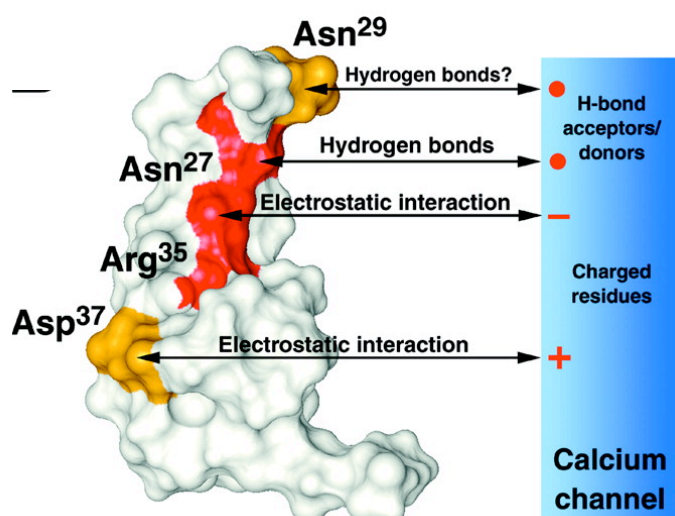

Figure 1.4

Molecular surface of the three-dimensional structure of the β -hairpin of ω -ACTX-Hv1a, which showed the proposed interaction between residues in the β -hairpin and insect voltage-gated calcium channels. The side chains of the key interacting residues (Asn²⁷ and Arg³⁵) form a contiguous patch (shown in red) on the surface of the β -hairpin, and this patch is flanked by two residues (Asn²⁹ and Asp³⁷, shown in yellow) that are proposed to be for the toxin-channel interaction (Tedford et al., 2001).

Hv1a toxin could be synthesized directly or produced in prokaryotic expression systems like *E. coli* and eukaryotic expression systems such as yeast *Pichia pastoris* and plant expression systems (Tedford et al., 2001; Khan et al., 2006; Fitches et al., 2012; Bonning et al., 2014). For synthetic Hv1a toxin, the reported ED₅₀ against the cotton bollworm *Heliothis armigera* (*H. armigera*) is 3nmol/g (Atkinson et al., 1999). In addition, the PD₅₀ of synthetic Hv1a reported for the tobacco hornworm *Heliothis virescens* (*H. armigera*) is 250pmol/g, which is much lower than the LD₅₀ of the recombinant Hv1a toxin produced in *E. coli* (Bloomquist, 2003). This showed synthetic Hv1a toxin, just like native Hv1a toxin, was active and toxic to insect pest *in vivo*.

Although it was not very easy to express Hv1a toxin in *E. coli* due to its high number of disulfide bridges, Tedford in 2001 expressed a fusion of Hv1a toxin to the C- terminus of GST as a recombinant fusion protein in the thioredoxin-deficient *E. coli* strain, which was proven to be active to house crickets, with increased the LD₅₀ by less than 2-fold (Tedford et al., 2001). Furthermore, Hv1a, when expressed in *E. coli* as another fusion protein (pSAK-III construct containing Hv1a gene) (Khan et al., 2006), the purified recombinant Hv1a toxin could also cause mortality of *H. armigera* and *Spodoptera littoralis* (*S. littoralis*) caterpillars when applied topically. The LD₅₀ at 12 h after application was determined to be approximately 4 and 2 pmol of toxin per gram body weight of *H. armigera* and *S. littoralis* larvae, respectively (Khan et al., 2006).

Normally, it should be easier to express Hv1a toxin in yeast than in bacteria, as yeast is a commonly used expression system for the production of eukaryote proteins and has the ability to proceed to a post-translational modification. Many spider toxins and their fusion proteins were successfully produced by yeast *Pichia pastoris* when correct expression constructs were established and verified (Fitches et al., 2010 and 2012; Gatehouse et al., 2013). However, as to Hv1a toxin, the purified recombinant Hv1a produced in yeast showed little toxicity to insect pest ascribed to no proper disulfide-bridge folding of Hv1a toxin (Fitches et al., 2012).

In the plant expression system, as another eukaryotic expression system, Hv1a was produced to be orally active against the Lepidopteran *S. littoralis* and *H. armigera* when it expressed in *Nicotiana tabacum* (*N. tabacum*) (Khan et al., 2006). Moreover, Hv1a toxin has been proved to be orally active against ticks (Mukherjee et al., 2006). Nevertheless, Hv1a alone showed little orally toxic when fed to *M.*

brassicae larvae, Dipteran (*Musca domestica*; housefly), Hemipteran (*Acyrtosiphon pisum*; pea aphid) and peach potato aphid (*Myzus persicae*) insects (Fitches et al., 2012; Gatehouse et al., 2013).

When the recombinant Hv1a toxin joined its C-terminus to the N-terminus of GNA and was incorporated into the Hv1a/GNA fusion protein, it showed more toxicity to *M. brassicae* larvae by injection than its component Hv1a toxin or GNA (Fitches et al., 2012). From the injection results, 50-100 mg toxin/g insect of Hv1a/GNA fusion protein could cause 50% mortality to *M. brassicae* larvae (Fitches et al., 2012). Moreover, Hv1a/GNA fusion protein was also orally insecticidal towards *M. brassicae* larvae in both cabbage leaf disc and droplet feeding assays (Fitches et al., 2012). Hv1a/ GNA gave rise to a significant reduction in growth and survival of fifth stadium *M. brassicae* larvae. It caused 80% of second stadium larval mortality within 10 days on leaf discs coated with Hv1a/GNA (0.1–0.2% w/v). However, the component Hv1a or GNA had almost no effect on the survival of larvae compared to the Hv1a/GNA fusion protein. According to the drop feeding experiments, droplets containing 40 µg of Hv1a/GNA fusion protein completely restricted the growth of fifth stadium larvae, in agreement with the paralytic activity of the toxin reported before (Fletcher et al., 1997; Tedford et al., 2004b). When the dose increased to 160 µg of fusion protein, fifth stadium larvae failed to emerge as pupae. By contrast, larvae exposed to droplets containing an equivalent dose of Hv1a showed no effect on the larvae (Fitches et al., 2012).

1.4.2.2. Engineered insect pathogens that directs delivery by acting as the “vector” of spider toxins, Bt toxins or spider/Bt fusion toxins

1.4.2.2.(i) Insect pathogens acting as a “vector” of spider toxins

There are some insect pathogens such as entomopathogenic fungi and baculoviruses, which are the natural enemies of insect pests and can transport spider toxins to haemolymph by acting as a vector (Bonning and Nusawardani, 2007; Whetstone and Hammock, 2007). The genes encoding toxin peptides could be engineered into entomopathogens and be produced in the insect host after pathogen infection, which was proven to be a beneficial method to avoid spider toxins being degraded by enzymes in the insect gut (Ikonopoulou and King, 2013). For example, some fungi, which have already been used for insect pest control, whilst

not ingested by the hosts, could penetrate the cuticle directly (Leger and Wang, 2010). Engineering *Metarhizium anisopliae* fungus (*M. anisopliae*) to overexpress its own cuticle degrading protease, Pr1 increased the efficacy of this fungus (St Leger et al., 1996). This is because large amount of Pr1 can cause more degradation of insect cuticle, which facilitates *M. anisopliae* to get into the haemolymph to infect the target insect pests easily. Furthermore, *M. anisopliae* fungus was also engineered to express *Androctonus australis* insect toxin (AaIT). The toxicity of AaIT in this engineered recombinant fungus was highly improved against the tobacco hornworm, *M. sexta*, mosquitoes and the coffee berry borer beetle, *Hypothenemus hampei* (Pava-Ripoll et al., 2008). Therefore, if *M. anisopliae* fungus was engineered to express spider toxins, these fusion proteins should be more insecticidal as the fungus could mediate transport of spider toxins to haemolymph by acting as the vector.

Engineered baculoviruses (nuclear polyhedrosis virus; NPV), as arthropod specific viruses, which could express the genes of toxic peptides from spiders or scorpions improved the activities of spider or scorpions toxins against insects by reducing the time between their application and cessation of feeding or death have been used as natural insect biological control agents for protection crop (Entwistle and Evans, 1985; Maggio et al., 2010). For example, *Buthus tamulus* insect-selective toxin (ButaIT) isolated from the Indian red scorpion *M. tamulus* was successfully expressed with biological activity by this insect virus (Rajendra et al., 2006). The recombinant ButaIT-NPV showed improved toxicity on the larvae of the tobacco budworm, *Heliothis virescens* proved by reduction in median survival time (ST₅₀) and in LD₅₀ compared to the wild type virus (Rajendra et al., 2006). Therefore, expression of highly toxic fusion proteins in engineered recombinant baculoviruses should be also feasible for crops with little tolerance to feeding damage and where speed-of-kill is an important characteristic.

1.4.2.2.(ii) *Bacillus thuringiensis* (Bt) toxins and their use in transgenic plant and engineered baculoviruses

Bacillus thuringiensis (Bt), which was first identified in 1902 by Ishiwatari (Jisha et al., 2013) is a gram-positive soil dwelling bacterium that possesses entomopathogenic properties. The crystal toxins produced during sporulation in this bacterium are responsible for its insecticidal activity (Angus, 1956). The genes

coding these toxins were present on plasmids of Bt (Aronson and Shai, 2001). Four kinds of toxins were produced from Bt and three toxins exist as forms of crystalline deposits (Cry or Cyt toxins), which include binary toxins, single toxins with three-domain structure (also truncated versions) and cytolytic single domain structured toxins. The fourth toxin class includes single and binary toxins that are expressed vegetatively by the bacterium (Vip) (Crickmore et al., 1998). The best characterised class of toxins, the Cry δ -endotoxins could cause mortalities of insect pests by a mechanism involving formation of pores in the membranes of gut epithelial cells (Morse et al., 2001). Importantly, the Cry toxins are known to decrease the risk of non-target effects, and are biodegradable in the environment, decrease the risk of accumulation of residues, which make these toxins beneficial when applied in crop protection with compared to chemical pesticides (Bravo et al., 2005). For this reason, Bt has been widely applied since 1920 as a biopesticide in spray formulations providing resistance to many insect pest species. Nowadays, biopesticides account for approximately 1% of all pesticides sold worldwide. Bt derived products make up approximately 80% of this figure (Whalon and Wingerd, 2003). Cry toxins show a high level of specificity towards insect species; individual toxins are rarely effective outside a restricted range of related insect species. Toxins from Bt which were highly insecticidal to the Lepidopteran (moth) and Coleopteran (beetle) pests have been engineered into plants such as cotton and corn to give highly effective protection against major pest species, which reduced the use of pesticides and crop production cost (Sanahuja et al., 2011). This use of transgenic plant technology has been commercially successful, although some kinds of pests have developed degrees of resistance to Bt toxins (Gassmann et al., 2011; Wan et al., 2012). However, Bt toxins effective against from some insect orders, such as sap-sucking Hemipteran pests have not been found, and consequently Bt toxins are not effective for managing them (Porcar et al., 2009; Li et al., 2011; Chougule and Bonning, 2012). With extended use of insect-resistant GM crops, the populations of Hemipteran pests increased due to the reduced use of chemical pesticides on Bt crops (Lu et al., 2010; Zhao et al., 2011). In order to delay or reduce potential for resistance and enhance the toxicities of Bt toxins, alternative strategies for control of insect pests had been investigated in recent years. One such approach was the expression of two or more Cry toxins from Bt in plants to increase the toxicities and the range of insect orders,

although this method was still not totally effective as mutants showing broad range resistance could still be found (Back, Ph.D. thesis; unpublished data). Another approach was that engineering plants with a fusion protein combining the N-terminal Bt toxin Cry1Ac with the C-terminal of the galactose-binding domain of the nontoxic ricin B-chain (RB) lectin (BtRB fusion protein) (Mehlo et al., 2005). RB, as a galactose- and *N*-acetylgalactosamine-specific lectin, has the ability to highly bind these residues and might be involved in the intracellular trafficking of the ricin toxin (Newton et al., 1992; Frigerio and Roberts, 1998; Mehlo et al., 2005). Therefore, the BtRB fusion protein including two binding domains was introduced. One binding domain was from Bt toxin Cry1Ac that could involve formation of pores in the membranes of gut epithelial cells (Morse et al., 2001). Another binding domain was from RB lectin that could play a broader role in the delivery of the highly toxic ricin toxin in insect pest (Newton et al., 1992). Therefore, the increasing number of binding domains on the fusion protein BtRB would allow itself to bind to a wider repertoire of receptors than any of its components. Furthermore, the increasing potential number of interactions at the molecular level in target insect pests also caused the reduction of resistance evolving in populations of insect pest because mutations occurring on several different receptors concurrently are almost impossible due to the fitness cost (Mehlo et al., 2005; Fenton et al., 2010). From the bioassay results of transgenic rice and maize plants that were engineered to express the fusion protein BtRB, the fusion protein showed more insecticidal activity to the stem borer (*C. suppressalis*), which is normally susceptible to Cry1Ac, than the components of Cry1Ac. In addition, the fusion protein is also significantly toxic to cotton leaf worm (*S. littoralis*), which is tolerant to Bt toxin Cry1Ac. BtRB caused almost 78% mortality of *S. littoralis* by day 4, while mortality on the plants that only expressed Cry1Ac alone was <20% by day 4. The results confirmed that fusion of Cry1Ac toxin to the RB lectin domain extended the range of insecticidal spectrum of Bt toxins (Mehlo et al., 2005).

Bt toxins have also been used as insecticidal components in engineered recombinant baculoviruses. For example, the insecticidal activity of baculoviruses was improved by expressing an insecticidal toxin gene at an early stage of viral infection by fusion to early-expressed promoters from *Cotesia plutellae* bracovirus (CpBV) (Choi et al., 2008). The genes of insect-specific toxins and Bt toxins were also successfully introduced into the genomes of recombinant baculovirus to express

fusion proteins, Bt toxins/insect-specific toxins, under the control of endogenous promoters in the recombinant baculoviruses (Shim et al., 2009).

1.4.2.2.(iii) Baculoviruses acting as a “vector” of spider/Bt fusion toxins

In an extension of the technology of expressing Bt toxins/insect-specific toxins under the control of endogenous promoters in the recombinant baculoviruses, if both spider toxin genes and Bt toxin genes were introduced into recombinant baculovirus genomes, the expressed fusion proteins would result in significantly increased toxicities compared to single components alone. The fusion proteins solved two key problems: the spider neurotoxins that have effective activities on the large range of pests could be introduced to the haemolymph of pests by Bt toxins acting as a carrier, when baculovirus infection occurred. The toxicities of Bt toxins against different kinds of pests were definitely enhanced due to fusion with spider toxins. For example, co-expression of Av-Tox2 toxin from spider *Araneus ventricosus* and cry1-5 crystal protein of Bt toxins to make a fusion protein ApPolh53006AvTox2 improved the insecticidal activity of a novel recombinant *Autographa californica* nucleopolyhedrovirus (AcMNPV) under the control of early promoter from CpBV. The LD₅₀ value of this ApPolh53006AvTox2 fusion protein against both *Plutella xylostella* and *Spodoptera exigua* larvae was significantly reduced with compared to its components, which implied that fusion of spider toxins to Bt toxins could improve the toxicities of baculoviruses (Jung et al., 2012). In another example (Cao et al., 2010), co-expression of the spider *Atrax robustus* ACTX-Ar1 gene encoding an ω -atracotoxin and another gene encoding the Bt-toxin C-peptide to form a fusion protein ω -ACTX-Ar1/C-peptide of Cry IA(b) in transgenic poplar *Populus simonii* x *P. nigra* L. (Malphigiales: Salicaceae) was proven to be very effective against the Asian gypsy moth *Lymantria dispar* (L.) (Lepidoptera: Lymantriidae). This fusion protein significantly restricted the growth, development and pupation of *L. dispar* feeding on the transgenic poplar compared to a control group fed on non-transgenic poplar. Moreover, much more mortality (92%) was found in the group fed on transgenic poplar leaves than control group (16.7%) during all stages of larvae. Therefore, fusion of spider toxins to Bt toxins as recombinant fusion proteins should be a potentially successful method for combatting insect pests

1.4.2.3. Plant virus proteins that mediate delivery by acting as the “coat”

1.4.2.3.(i) Plant virus proteins

Most plant viruses are transmitted by sap-sucking insects (Hemiptera) including aphids, whiteflies, leafhoppers, plant hoppers, and thrips. More than half of these viruses are vectored by aphids (Hogenhout et al., 2008). The continuously transmitted plant viruses can get to the haemolymph of insect vector when they are ingested during vector feeding on plant sap before being transmitted to other plants via the salivary glands of insects (Tamborindeguy et al., 2010). Therefore, the potential ability of plant viruses to deliver insect-specific toxins from the gut epithelium into haemolymph by transcytosis is thought to be very effective since these viruses, which acts as a “coat”, can prevent venom peptides from being degraded (Bonning and Chougule, 2013). However, these viruses cannot get into haemolymph by themselves. Instead, they are transported across the gut epithelium of insect pest like aphid vectors to haemolymph by clathrin-coated vesicles (Gray and Gildow, 2003). Clathrin-coated vesicles are also able to mediate viruses across the accessory of salivary gland into the duct of the salivary gland from haemolymph of aphid (Bonning and Chougule, 2013).

1.4.2.3.(ii) Application of Plant virus proteins

The potential of this transport mechanism to deliver toxins to the insect haemolymph has been proven by Bonning in 2014. The sequence of luteovirus coat protein (CP) (the stop codon of the CP sequence has been replaced by a sense codon) was fused to the sequence of proline-rich region of the CP read-through domain (CP-P), both of which come from the Pea enation mosaic virus (PEMV). The CP-P sequence was then fused to GFP sequence (CP-P-GFP). Green fluorescence was seen in the pericardial cells of the pea aphid after feeding on CP-P-GFP fusion protein. Firstly, this implied that CP-P could transport GFP across the gut epithelium of pea aphid to haemolymph and CP-P fusion protein was removed from the haemolymph by the pericardial cells after finishing transport. Secondly, this also indicated that the structure of the CP virus imposed no restrictions on the transcytosis of the CP-P-GFP from gut to haemolymph. However, aphids fed GFP alone showed only background fluorescence implying that in the absence of CP-P, GFP could not be transported (Bonning et al., 2014).

1.4.2.3.(iii) Plant virus proteins acting as a “coat” protein of spider peptide toxins

Another fusion protein PEMV CP-P-Hv1a that fused CP-P to the spider neurotoxin ω -atracotoxin-Hv1a was demonstrated to be very insecticidal to four species of aphids including green peach aphid (*M. persicae*), the pea aphid (*A. pisum*), the bird cherry-oat aphid (*R. padi*) and the soybean aphid, *Aphis glycines* in membrane feeding assays or through transgenic *Arabidopsis* feeding assays. A concentration of 150 ng/ μ l CP-P-Hv1a could lead to significantly mortality of these four species of aphids (Bonning et al., 2014). Western blot analysis demonstrated that CP-P-Hv1a could be transported across gut epithelium to haemolymph from aphids fed on CP-P-Hv1a fusion protein (Bonning et al., 2014). Specifically, bioassays were analyzed with *M. persicae* on T2 *Arabidopsis* plants expressing CP-P-Hv1a fusion protein. Strains expressing CP-P-Hv1a showed significantly lower aphid numbers per plant by day 17 and numbers were suppressed after 17 days, whereas strains just expressing Hv1a showed higher and higher aphid number per plant day by day. The stems and leaves of plants expressing Hv1a were heavily infested with aphids as compared to plants expressing CP-P-Hv1a. At last, serious aphid infestation led to necrosis and damage of all plants expressing Hv1a by day 17, which meant that spider neurotoxin Hv1a could not get across the aphid gut into haemolymph without fusion to plant viruses CP (Bonning et al., 2014). Previous results had shown that the CP of Barley yellow dwarf virus was also functional in toxin transport (Miller and Bonning, 2007). Transcytosis system of the plant virus CP depending on clathrin-coated vesicles is a quite effective and specific system. Therefore, in the future, modified PEMV CP may mediate uptake of toxic proteins into the haemolymph of non-vector insects such as Lepidopterans and Dipterans.

1.4.3. Expression of spider toxins and their fusion proteins

The expression system of the recombinant toxins or fusion proteins can be either prokaryotic or eukaryotic. Suitable expression systems include bacterial expression systems like *E. coli* and yeast expression systems like *P. pastoris*

1.4.3.(i) Expression of spider peptide proteins using bacterial expression systems

Bacterial expression systems have been known and used for many years with the

common cloning bacterium *E. coli* being the most often-used expression host (Chen, 2012) and for some proteins, *E. coli* expression system is not only able to express them at high levels, but is also able to mediate protein folding to produce biologically active products (Gordon et al., 2008; Koehn and Hunt, 2009). However, insecticidal secreted neurotoxins isolated from spider venoms are rich in cysteine residues and so require correct disulphide bridge formation to reach their biological activity. Therefore, expression of recombinant spider toxins has been limited to bacterial expression systems using *E. coli* ascribed to the physiological features of *E. coli* that do not possess a similar post-translational modification system like eukaryotic cells (de Marco, 2009). For example, κ -ACTX-Hv1c and ω -ACTX-Hv1a were only expressed functionally in *E. coli* as GST fusion proteins. (Tedford et al. 2001; Maggio and King, 2002a, b). Although expression of these spider toxins with fusion to other proteins in bacterial expression systems was successful, the functional product was often little. For example, the production of Hv1a toxin expressed by *E. coli* in our lab was only 2-3mg/L, while the production reached 32mg/L when expressed by yeast (data not shown). Moreover, it was very difficult to purify these proteins, usually including a lengthy process with only protein expressed in soluble fractions able to be recovered with any ease (Back, Ph.D. thesis; unpublished data). Actually, many spider toxins expressed in *E. coli* were presented as insoluble masses that often need a process of refolding to be functional *in vitro* (Ni and Chen, 2009; Chen, 2012). Although using affinity chromatography of incorporation toxins with GST tag was proven to be feasible, large amount of cost of this purification method made these toxins in this system commercially unfeasible.

1.4.3.(ii) Expression of spider toxins and their fusion proteins using yeast expression systems

Although a microorganism which can be grown under simple conditions, yeast is a eukaryote, so yeast protein expression systems can carry out much complex post-translational processing dependent on the presence of endoplasmic reticulum (ER). Yeast possesses the necessary enzymes to process proteins for glycosylation, Pro-region cleavage, proteolytic cleavage and disulphide bond formation. Therefore, this system is better than the bacterial expression system in expressing many eukaryotic proteins, which contain post-translational modifications (Higgins and

Creggs, 1998). Many proteins, which are insoluble or inactive when expressed in *E. coli* can be expressed in yeast as functional, active products. The preferred large-scale protein expression host utilized is the yeast *P. pastoris* because it grows rapidly and is easy to manipulate. It can also achieve high culturing cell densities and subsequently give higher protein yields (Cereghino and Cregg, 2000). Furthermore, it is able to eliminate endotoxin and bacteriophage contamination and plays a role in ease of genetic manipulation of well-characterized yeast expression vectors (Higgins and Cregg, 1998; Cereghino et al., 2002). Importantly, *P. pastoris* has no known human pathogenicity in the spectrum of lytic viruses that prey on humans and has the ability to engineer secreted proteins that can be purified from growth medium directly with no need to harvest the yeast cells (Li et al., 2007).

Normally, expression of a target spider toxin gene in *P. pastoris* requires three steps: (1), the insertion of the target gene isolating from spider venom into an expression vector; (2) integration of the expression vector into the *P. pastoris* genome according to the method of yeast transformation; (3) selection of potentially expressing strains for the target gene (Li et al., 2007). An expression cassette, which is composed of a promoter sequence, a transcriptional termination sequence derived from AOX1 that directs efficient 3' processing and polyadenylation of the mRNAs, and multiple cloning sites between them for insertion of the target gene is essential for the whole expression vector (Koutz et al., 1989). For secreted spider proteins, sequences encoding a secretion signal like the *Saccharomyces cerevisiae* alpha-factor prepropeptide, which are in frame with the target gene, are necessary (Li et al., 2007). Moreover, one of the promoter sequences that is normally used in the yeast expression cassette is the GAP promoter. It is derived from the *P. pastoris* glyceraldehyde-3-phosphate dehydrogenase (GAP) gene (Waterham et al., 1997). This promoter is very useful in the production of secreted proteins, as methanol is not required for induction and it is also not necessary to shift cultures from one carbon source to another if the GAP promoter is used (Li et al., 2007)

The expression system used in *P. pastoris* allows proteins to be secreted into the culture supernatant, which makes purification and other down-stream processing much more straightforward for large-scale production. Specifically, *P. pastoris* vectors, such as pGAPZ α , include sequences encoding alpha-factor prepropeptide, which is attached to the sequence encoding the desired protein product as an N-

terminal fusion. In fact, this secretion is already a kind of purification method, because most of the yeast endogenous proteins present in the cell are not secreted to culture medium. The culture medium contains only a few yeast proteins, which makes the purification of recombinant protein relatively easy. But for wild type yeast strains like X-33 strain, many endogenous proteases exist in the cell and in the supernatant, which can lead to unnecessary cleavage of recombinant proteins. For this defect, *pepA* protease deficient strains e.g. SMD1168H have been developed and are used as new-type *Pichia* protein expression hosts.

Proteins such as spider insecticidal toxins, lectins such as GNA, and their fusion proteins peptides/GNA have been successfully expressed by using *Pichia* protein expression systems, avoiding the problems with insolubility and lack of biological activity experienced when expression in *E. coli* was attempted. For example, the heterodimeric and homodimeric garlic lectins ASAI and ASAII were successfully expressed as recombinant proteins by using *Pichia* protein expression system. ASAI and ASAII were both toxic to pea aphids (*A. pisum*) in artificial diets after droplet feeding (Fitches et al., 2008), which showed that these two lectins were all biologically functional after expression and modification in yeast, suggesting the post-translational ability of *P. pastoris*. Another lectin GNA could be also expressed by *P. pastoris* at a yield of approximately 80 mg/L at the 200 L scale, and was purified to 95% homogeneity using hydrophobic interaction chromatography (Baumgartner, et al., 2003). Recombinant spider insecticidal neurotoxins also succeeded in being expressed in yeast with biological activities. For example, the recombinant toxin SF11 was expressed in functional form in *P. pastoris* with expression levels at 0.5-5 mg/L culture medium. Moreover, its fusion protein SF11/GNA also had high production after yeast expression and was more insecticidal to the insect pest than SF11 toxin alone and GNA itself (Fitches et al., 2004). However, some cleavage of fusion proteins occurred during expression despite the use of a protease-deficient host strain SMD1168H. They were divided into toxins and GNA components again by yeast KEX2 enzyme, which can recognize the specific cleavage site with EKRE amino acids (Fitches et al., 2012). To address this problem, some modification was done to remove the cleavage site by substitution of the original amino acid via site-mutation PCR methods, which is proven to be successful. For example, MODHv1a/GNA corresponds to the modified form of Hv1a/GNA, where a single amino acid change at the C-terminus of Hv1a has been

shown to improve expression of intact fusion protein but has equivalent toxicity to Hv1a/GNA (Pyati et al., 2014).

In order to improve the yield of toxins and fusion proteins as much as possible, rapid affinity purification of specific proteins with additions of tagging sequences, such as (His)₆ tag, has been widely developed during protein production. The added tags can not only isolate the target recombinant protein from total proteins in yeast, but also collect recombinant protein without any loss as soon as possible. This affinity method reduces the exposure time of target protein in the culture supernatant where proteases exist so reduces the opportunity for degradation.

1.5 The applications of spider toxins and their fusion proteins in pharmacy and in crop protection

1.5.1 Spider neurotoxins as leads for drug development

Nowadays, many neurotoxins have been isolated from the venom of Arachnids and have been researched by scientists. Spider venoms are rich in stable peptides selected by nature that potently modulate the activity of a wide range of neuronal ion channels and receptors (Escoubas and Bosmans, 2007). Up to now, there were five main classes of ion channels targeted by the spider neurotoxins: voltage-gated potassium (K_v), calcium (Ca_v) and sodium (Na_v) ion channels, acid-sensing ion channels (ASICs) and mechano-sensitive ion channels (MSCs) (Escoubas et al., 2000a; Corzo and Escoubas, 2003; Estrada et al., 2007). They can bind the receptors of ion channels to give rise to numbing of the nervous system or causing hyperexcitability of the nerve system leading to convulsions and paralysis (King and Hardy, 2013; Ikonomopoulou and King, 2013). Moreover, a beneficial advantage of spider natural peptides is their selectivity. This is very helpful in designing safer and efficacious drugs, as they have the potential to target specific receptors precisely and avoid binding wrong receptor in the same cell (Escoubas and Bosmans, 2007). Therefore, peptide structure–function research plays a central role in effective and poison free drug selection. Some of these toxins have been studied to develop novel pharmaceuticals to treat cardiovascular diseases, cancer, neuromuscular diseases, chronic pain, stroke victims, inflammation and erectile dysfunction (Saez et al., 2010). For example, the form of potassium conductances depends on the Kv2 and

Kv4 ion channels and helps to underpin the repolarisation of the cardiac myocyte membrane, making the use of toxins affecting potassium channels a potential basis for drugs to treat heart attacks (Roden et al., 2002). In the venom of Spiders, some neurotoxins, which target Kv2 and Kv4 ion channels, should be potential modulators and important sources of targeted cardiovascular drug (Escoubas and Bosmans, 2007). Another example is about the peptides targeting Na_v channels and ASICs. They could mediate pain perception because of their widespread expression in nociceptive neurons. Many authors have suggested that these peptides could be used to alleviate moderate-to-severe chronic pain. Recently, ASIC1 has been found to be active in pain resulting from inflammation and other pathological conditions such as brain ischaemia and stroke and can be developed as novel classes of analgesics (Waldmann et al., 1999, 2001). Psalmotoxin 1 (PcTx1) isolated from tarantula venom is a highly selective and high-affinity inhibitor of homomeric ASIC1a channels, which has already been trialled as a potential analgesic drug for pain relief (Escoubas et al., 2000b). Furthermore, the peptides targeting Na_v1.7 channels, which are considered to be a major novel target for the development of new analgesics, play a key role in pain perception in humans (Cox et al., 2006).

1.5.2 Applications of spider toxins for control of insect pests as bio-insecticides

Compared to chemical pesticides, unmodified spider toxins have limited potential as insecticides, as they cannot get across to the central nervous system from gut epithelium (Fitches et al., 2001, 2012; Ikonopoulou and King, 2013). Therefore, only by improving oral or topical toxicity of spider toxins to insects can applications for crop protection be envisaged. The exploitation of spider toxins can be developed by using vector-based delivery methods. For example, fusion of spider toxins to GNA or incorporation of spider toxins into entomopathogens can both infect insect pests. The uses for spider toxins as bio-insecticides that have been envisaged are based on incorporation into sprays or baits (toxins/GNA fusion proteins can be dissolved in some solution as candidates of sprays), or expression from transgenes encoding the peptides or peptides/GNA that could be engineered into crops or into entomopathogens such as viruses and fungi (Fig. 1.5) (Ikonopoulou and King, 2013).

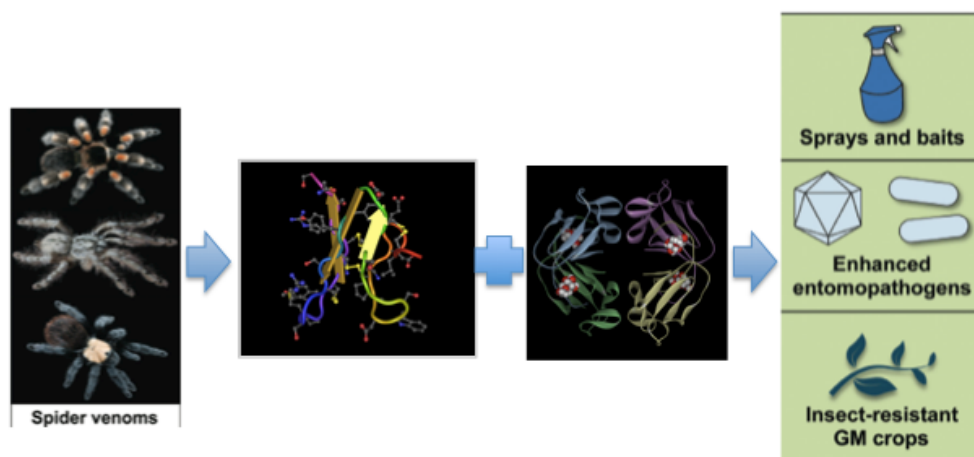

Figure 1.5

Schematic of insect control options available for spider toxins. The central panel is a schematic of the spider-venom peptide in fusion with GNA, which can be incorporated into entomopathogens or engineered into crops in order to enhance the toxicity of entomopathogens or crop plants to infect insect pests. Spider fusion proteins can be also incorporated into sprays or baits (Ikonomopoulou and King, 2013; King and Hardy, 2013; Yang et al., 2014a, b).

1.5.3. Engineering spider toxins or their fusion proteins into crop plants using transgenesis technology

Insect-resistant genetically modified (GM) crops have been used for many years (King and Hardy, 2013). Scientists tried to engineer plants such as tobacco, cotton and agricultural crops expressing insecticidal spider toxins, which target different insect ion voltage-gate channels with no activities on members of other taxons or mammals (Khan et al., 2006; Vassilevski et al., 2009; Omar and Chatha, 2012). Therefore, peptide proteins from spider venoms should be good candidates for engineering GM crops to resist insect pests attack. For example, the toxin, Magi 6, from the spider *Macrothele gigas*, has been expressed in tobacco. The protein accounted for 4 to 6% of total soluble proteins. The transgenic tobacco was conferred resistance to *Spodoptera frugiperda* (Hernández-Campuzano et al., 2009). Moreover, insect-resistant GM crops carrying the insecticidal protein from the bacterium *Bacillus thuringiensis* (Bt) could increasingly resist the crop pests and delay the breeding (Que et al., 2010). Bt toxins have their special mechanisms of function by involving formation of pores in the membranes of gut epithelial cells that can help to highly express spider toxins by incorporation of transgenes encoding spider-venom peptides into the Bt genome (Morse et al., 2001). So the toxicities of Bt toxins against pests should be enhanced if constitutive expression of spider toxins in engineering Bt plants by different transgene approaches like pyramiding or trait stacking, both of which refer to the process of combining two or more genes of interest into a single plant (Moar and Anilkumar, 2007). Moreover, Bt toxins can also lead to lysis of midgut epithelial cells, which are able to mediate spider peptides into insect haemolymph, especially against the insect orders Lepidoptera, Coleoptera, Hymenoptera, and Diptera (Bravo et al., 2007; King and Hardy, 2013). Furthermore, engineering plants to express spider fusion proteins via fusing the genes of spider toxins to GNA or plant viruses coat protein (CP) genes should be a another distinct approach since GNA acts a “carrier” domain in the fusion protein and helps to mediate transport of toxins across the gut epithelium and to sites of central nervous system of insect; or plant viruses CP can deliver insect-specific toxins into haemolymph, which has been introduced above (Fitches et al, 2012; Bonning and Chougule, 2013).

In summary, disulfide-rich spider-venom peptides, which can form a cysteine-knot inhibitor structure, are promising candidates for bio-insecticides due to their

invertebrate selectivity, chemical and thermal stability and large amount of yield in the yeast fermentation. Furthermore, their insecticidal activities can be significantly improved by fusing them to GNA, engineering into entomopathogens or via fusion to plant virus coat proteins. Even more important, they not only have a broad application in novel pharmacology, but also are able to be expressed in plant crops.

1.6 Aims and objectives:

The aim of this project was about the exploitation of small cysteine-rich spider neurotoxins and their fusion proteins as bio-insecticides for the protection of crop plants against pest species including larvae and adults such as Orthopterans, Homopterans, Heteropterans, Coleopterans, Lepidopterans, Hemipteran and Dipterans. The yeast expression system was the main method used to produce fusion proteins. GNA acted as a carrier.

The objectives were:

- 1) To clone, express and analyse biological activities of recombinant δ -amaurobitoxin P11a and the fusion protein P11a/GNA comprised of P11a linked to the N-terminus of GNA.
- 2) To provide evidence to show that fusion to GNA enhances the insecticidal activity of P11a against cabbage moth (*M. brassicae*), cereal aphid (*S. avenae* F.), pea aphid (*A. pisum*), peach-potato aphids (*M. persicae*) and housefly (*M. domestica*) by injection or feeding assays.
- 3) To investigate new methods of improving the folding of recombinant toxins by inclusion of the Pro-region in the expression constructs including Ao1bPro-P11a, Ao1bPro-P11a/GNA, Hv1aPro-P11a/GNA, Pro-Hv1a, Pro-Hv1aGNA and Pro-Ec2a/GNA and make comparisons with recombinant toxins or fusion proteins without Pro-region in the expression constructs: P11a, P11a/GNA, Hv1a, Hv1aGNA, Ec2a/GNA.
- 4) To provide evidence to show that recombinant toxins or fusion proteins by inclusion of the Pro-region in the expression constructs not only highly enhances the insecticidal activity of toxins themselves, but also significantly enhances the toxicity of the fusion proteins against cabbage moth (*M. brassicae*), cereal aphid (*S. avenae* F.), pea aphid (*A. pisum*), peach-potato

aphids (*M. persicae*) and housefly (*M. domestica*) by injection or feeding assays.

- 5) To compare the toxicity of P11a/GNA and Hv1a/GNA fusion proteins towards wild-type and pyrethroid-resistant strains of peach-potato aphids (*M. persicae*), and to provide evidence to show that the toxicity of P11a/GNA is reduced by the *kdr* and *super-kdr* mutations in the sodium channel, but the toxicity of Pro-Hv1a/GNA fusion protein, which targets insect calcium ion channel is not.
- 6) To produce transgenic *Arabidopsis thaliana* expressing insecticidal fusion protein Pro-Hv1a/GNA and to provide evidence to show the enhanced toxicity to the target insect pests of positive homozygous plants in contrast to Hv1a/GNA.

CHAPTER 2 MATERIALS AND METHODS

2.1 Chemicals and reagents

Chemicals and reagents were of analytical grade and were provided by Sigma or BDH Chemical Company otherwise stated. Restriction enzymes and other molecular biology reagents were supplied by Fermentas, NEB or Promega.

2.2 Insect rearing

2.2.1 *Mamestra brassicae* (cabbage moth)

M. brassicae (cabbage moth) originally obtained from cultures held in Food and Environment Research Agency (FERA) were reared at the University of Durham continuously on a standard Lepidopteran artificial diet (Bown et al., 1997) at 25° C, 40% relative humidity under a 16h light, 8h dark regime.

2.2.2 Cereal aphid (*Sitobion avenae* F.) and pea aphid (*Acyrtosiphon pisum*)

Cereal aphid (*Sitobion avenae* F.) and pea aphid (*Acyrtosiphon pisum*) were cultured on plants of oat (*Avena sativa* L. cv. Coastblack) and broad bean (*Vicia faba* cv. Sutton Dwarf) seedlings, respectively, under a 12h light, 12h dark regime, maintained at 18°C, 70% relative humidity.

2.2.3 Wild-type *Myzus persicae* (Sulzer) (Hemiptera: Aphididae) (peach-potato aphid) strain (4106A) and pyrethroid-resistance *Myzus* strains (794J, UKO and 4824J)

The mutant strains of peach-potato aphid, *Myzus persicae* (Sulzer) (Hemiptera: Aphididae) were kindly provided by Prof. Linda M. Field (Department of Biological Chemistry and Crop Protection, Rothamsted Research, UK). Strain 4106A has no mutation (*wild type*). Strain 794J is homozygous for the mutation L1014F (*kdr*), and is resistant to pyrethroids. Strain UKO is homozygous for the mutation M918L (*super-kdr*), and shows enhanced resistance to pyrethroids. 4824J is homozygous for L1014F (*kdr*) and M918T (*super-kdr*), and shows immunity to pyrethroids (Eleftherianos et al., 2008). Aphids were cultured on fresh Chinese Leaf under

conditions of 12h light, 12h dark, 18°C, 70% relative humidity.

2.2.4 *Musca domestica* (housefly)

Musca domestica (housefly) larvae were maintained on a wheat flour diet at 25°C, 40% relative humidity under a 16 h light, 8 h dark regime; adults were given 10% sucrose solution *ad libitum*.

2.3 Statistical analysis

All data were analysed using Kaplan–Meier survival analysis, using Prism (v. 5) software. All other data analysis was carried out using Origin 8.5 graphing and data analysis software. ANOVA analysis (with Bonferroni-Dunn post-hoc tests and Mantel Cox tests) was implemented to determine any significant differences between treatments in the bioassay parameters measured. Bliss analysis software was carried out to calculate the LD₅₀ of insect pest.

2.4 Standard molecular biological techniques

All standard molecular biological techniques carried out were based upon protocols that can be found in Molecular Cloning: A Laboratory Manual (Sambrook and Russell, 2001; Green and Sambrook, 2012).

2.4.1 Oligonucleotides

Oligonucleotides used to synthesize all constructs were from Sigma Genosys, which were re-suspended in nuclease free water to a final concentration of 100mM according to the manufacturers quality control information.

2.4.2 Bacterial culture technology

For small-scale bacterial culturing, colonies picked from bacteriological agar plates or 2-5 µl of glycerol stock were grown in autoclave sterilized 5 ml Luria-Bertani (LB) (1% (w/v) Trypticase Peptone, 0.5% (w/v) Yeast Extract, 1% (w/v) Sodium chloride) liquid cultures. Antibiotics such as kanamycin or spectinomycin were added where they are necessary at the recommended suitable concentration. Low salt Luria-Bertani (LSLB) (0.5% (w/v) sodium chloride) was used in place of LB where zeocin (Invitrogen) was used. Cultures were grown overnight at 37°C on

an orbital shaker set at approximately 200-220rpm. Appropriate antibiotics were added to autoclave sterilized bacteriological agar (LB as above with 1.5% (w/v) difico agar) when the agar was approximately 40-50°C in order to avoid antibiotic breakdown. Sterile microbiological technique was used in all cases.

2.4.3 Plasmid DNA mini-preparations

Isolation of plasmid DNA was carried out based upon the alkaline lysis method using the Wizard *plus* SV minipreps DNA purification obtained from Promega. In all cases, the protocol supplied by the manufacturer was followed to obtain plasmid DNA.

2.4.4 Restriction endonuclease digestions

All restriction endonuclease enzymes were obtained from a number of suppliers (Promega, Fermentas, Thermo Scientific and New England Biolabs). Typically, the reactions were 20-50 µl in volume using 2-5 µg of isolated plasmid DNA, 1x appropriate enzyme buffer, 1 to 5 units of enzyme with the addition of sterile distilled water up to the required volume. Reactions were incubated in a heat block set at 37°C for 3 hours or overnight when complete digestion was required.

2.4.5 Polymerase chain reactions (PCR)

Reactions were carried out in an Applied Biosystems GeneAmp PCR system 2400 under standard conditions. Reaction volumes were typically 10-50 µl (1x PCR buffer containing 1.5 mM MgCl₂, 0.2 mM dNTPs (dATP, dCTP, dGTP and dTTP), each of 5' and 3' appropriate oligonucleotide primers at 0.2 µM, 0.1-2 µg DNA template. For high fidelity and proofreading amplification to be used in cloning of expression constructs, 0.5 µl Phusion polymerase (supplied by Thermo Scientific) was used. *Taq* polymerase was used for PCR-screening and colony PCR. Typically PCR reactions consisted of an initial denaturation step of 30-120 seconds at 98°C, 25-30 cycles of denaturation at 98°C for 30-60 seconds, annealing at 55-65°C (appropriate temperature for oligonucleotides used) for 30-100 seconds according to a length of template, extension at 72°C for 1-5 minutes and a final extension step of 10 minutes at 72°C.

2.4.6 Agarose gel electrophoresis of DNA

Agarose gel electrophoresis for the separation of DNA fragments is described in Molecular cloning (Sambrook and Russell, 2001; Green and Sambrook, 2012). DNA was visualised and photographed using a Geneflash Syngene UV cabinet with Pulnix camera. Images were obtained by using a Sony Video Graphic UP-895MD printer.

2.4.7 Purification of DNA from agarose gel

The relevant bands visualised on gel were excised using a single edged blade. The DNA was subsequently purified using a QIAquick gel extraction kit (QIAGEN) according to the manufacture instructions. All DNA was eluted in 20-30 μ l of supplied elution buffer.

2.4.8 Quantification of isolated DNA

DNA was quantified using a Thermo Scientific NanoDropTM 1000 Spectrophotometer under highly accurate UV-Vis analysis of 2 μ l samples. Sterile distilled water was used as a blank measurement.

2.4.9 Ligation of DNA

Ligations were carried out using 1 μ l T4 DNA ligase and 1 μ l 10xligase buffer (Promega) in a 10 μ l reaction. The ratio of plasmid DNA to insert DNA was typically 1:3 based upon the concentration. Total volume of plasmid DNA and insert DNA was 8 μ l. Reactions were left overnight at 4°C to ensure complete ligation.

2.4.10 Directed base site mutagenesis

The site-directed mutagenesis was a molecular biology method that allowed for making specific and intentional changes to the DNA sequence of any gene products. PCR mixture was prepared as follows: 10 μ l of 5x HF Buffer, 1 μ l of dNTPs, 2.5 μ l of 5' Forward (10 μ M) and 3' Reverse (10 μ M) primers, respectively, 1 μ l of template (normally plasmid), 0.5 μ l of phusion polymerase (Thermo Scientific) and 32.5 μ l of sterile distilled water to a final volume 50 μ l. PCR reaction was consisted of an initial denaturation step of 30 seconds at 98°C, 25 cycles of denaturation at 98°C for 10 seconds, annealing at 55-65°C (appropriate temperature for oligonucleotides used) for 10 seconds, extension at 72°C for 5 minutes and a final extension step of 7

minutes at 72°C.

After PCR reaction, the product was run on the gel. Gel extraction was then done in order to get the pure PCR product. The product was quantified by using nanodrop. After this, T4 Polynucleotide kinase reaction was set up in 20µl made up of 250ng linear plasmid, 4µl of 10x Kinase Buffer, 2µl of 0.1M ATP, 10-20U of T4 Kinase and sterile distilled water to a final volume 40µl (QIAGEN). The mixture was incubated at 37°C for 30 minutes. After incubation, sterile distilled water of 60µl was added into the mixture by following with QIAGEN elution protocol treating the 100µl rxn as a 100mg gel piece. After T4 Polynucleotide kinase reaction, T4 ligation reaction (Promega) with eluant in 10µl made up of 8.5µl linear plasmid, 0.5µl T4 Ligase and 1µl of T4 Ligase Buffer was set up.

2.4.11 Ethanol precipitation

NaAc (3 M) of 0.1 volumes were added to isolated DNA samples. Ice-cold ethanol of 2 volumes were added and mixed thoroughly by vortexing. Samples were incubated overnight at -20 °C and then centrifuged at 12,000 x g for 30 minutes at 4 °C. The supernatant was carefully removed. A concentration of 70% ethanol (750 ml) was added to the sample. This was vortexed again and centrifuged as previously described for 15 minutes. The supernatant was again removed and the pellet was placed in a dessicator to dry. Once fully dry, the pellet of DNA was re-suspended in the required volume of sterile distilled water.

2.4.12 Preparation of Electro-competent cells TOP10

One Shot TOP10 Electrocomp *Escherichia coli* cells of the genotype F- *mcrA* $\Delta(mrr-hsdRMS-mcrBC)$ $\phi 80lacZac$ $\phi \Delta lacX74$ *recA1* *araD139* $\Delta(araleu)7697$ *galU galK rpsL* (Str^R) *endA1 nupG* were first obtained from Invitrogen. Subsequent competent cells were produced using the following method. Two litres sterile baffled flasks containing 500 ml each of LB were inoculated overnight with bacterial culture. Cells were grown with shaking (220 rpm) at 37°C until exponential growth phase was reached ($OD_{600nm} = 0.4-0.6$, may take 2-3 hours). Flasks were chilled for 1 hour on ice. Cells were subsequently decanted into two sterile centrifugation tubes and pelleted by centrifugation (5000 x g for 10 minutes, 4°C). Supernatant was discarded and cells were re-suspended in a total volume of 500 ml ice-cold sterile 10%

glycerol and pelleted by centrifugation again. Supernatant was discarded and cells were washed with 500 ml ice-cold sterile 10% glycerol again. Supernatant was discarded again and cells were then re-suspended in 250 ml of ice-cold 10% glycerol and pelleted (6000 x g for 10 mins, 4°C). Finally cells were re-suspended in a total volume of 3.5ml ice cold 10% glycerol divided into aliquots of 50 µl that were then snap frozen in liquid nitrogen and stored at -80°C.

2.4.13 Transformation of TOP 10 electrocompetent *E. coli*

One Shot TOP10 Electrocomp *Escherichia coli* cells were taken out of -80°C storage and thawed on ice. The appropriate ligation reaction product of 1 µl was gently mixed with 50µl of the thawed competent cells. Electroporation was carried out using a Biorad Gene Pulser system following the manufacturer's *Escherichia coli* electroporation protocol. Cells were then placed on an orbital shaker at 37°C for one hour to allow for generation of antibiotic resistance. Cells were then plated out onto appropriate selection media plates.

2.4.14 Colony PCR

Transformed colonies of 8-10 were picked off the bacterial media plates on the following day. Each colony was re-suspended in a final volume of 10 µl PCR reaction (1µl of 10x PCR buffer containing 1.5 mM MgCl₂, 2 µl of 0.2 mM dNTP, 1 µl of each of 5' and 3' appropriate oligonucleotide primers at 10 µM, 0.5 µl *Taq* polymerase and 4.5 µl of sterile distilled water). Colony PCR reaction was as described previously in section 2.4.5.

2.4.15 DNA sequencing and analysis

When some colonies were proven to be positive after colony PCR, plasmids were extracted for the target gene sequencing. Appropriate vector and gene specific primers (GSP) were also used for target gene sequencing. Sequencing reactions were carried out using Applied Biosystems ABI Prism 3730 automated DNA sequencers, performed by the DNA sequencing service (DBS Genomics), School of Biological and Biomedical Sciences, University of Durham. The sequence data obtained was viewed and analysed using Sequencher software (version 4.5).

2.4.16 Glycerol stocks of *E.coli* clones

E.coli clones were grown overnight in LSLB with appropriate antibiotic at the specified concentration to prevent other bacterial growing. 650 µl of overnight culture was added to 350µl sterile 60% (v/v) glycerol in sterile cryovials and mixed. Cryovials were subsequently frozen in liquid nitrogen and transferred to -80°C for long-term storage.

2.5 Standard protein biological techniques

2.5.1 SMD1168H of the genotype *pep4* strains of *Pichia pastoris* yeast competent cells preparation (Invitrogen)

YPG of 10 ml, which contained 2% (w/v) trypticase peptone, 1% (w/v) yeast extract, 4% (v/v) glycerol, with a single colony of yeast strain, which grows on YPG plate (YPG as above with 1.5% (w/v) difico agar) was inoculated and grown overnight at 28-30°C in a shaking incubator (220 rpm). The OD600 of the overnight culture was determined to be between 3.0 and 5.0. Cells from the overnight culture were diluted to an OD600 of 0.1 to 0.2 in a total volume of 50 ml of YPG. The cells were grown at 28-30°C in a shaking incubator until the OD600 reached 0.6 to 1.0, which would take approximately 3 to 6 hours. The cells were pelleted by centrifugation at 500 g (1500 rpm) for 5 minutes at room temperature. The supernatant was then discarded. The cell pellet was re-suspended in 10 ml of Solution I. The cells were pelleted by centrifugation at 500 g (1500 rpm) for 5 minutes at room temperature. The supernatant was then discarded. The cell pellet was re-suspended in 1 ml of Solution I and aliquot into 50 µl aliquots in 1.5 ml sterile tubes. Cells were now competent and could be used immediately for transformation or stored for future use.

2.5.2 Linearization of plasmid DNA

In preparation for yeast transformation, plasmid DNA was linearized by using unique restriction enzymes *BlnI* (supplied by Roche, Basel, Switzerland) as follows: normally 5 µg of plasmid DNA for linearization, 10x enzyme activity buffer 30 µl, *BlnI* 4 µl and water to a final volume 300 µl. The reaction was conducted at 37°C overnight.

2.5.3 Transformation of competent cells of *Pichia pastoris* yeast

Selected clones (sequence confirmed) were cultured overnight at a speed of 220 rpm at 30°C for plasmid extraction. The plasmid was linearized overnight after extraction and quantification (Nanodrop) by using *BlnI*. Exact volume of reaction (300 µl) with adding 1/10 volume 3 M sodium acetate (30 µl) was measured. Double volume (660 µl) absolute ethanol was then added into the reaction to make a final volume of 990 µl for overnight precipitation at -20°C. The precipitation product was spun at a speed of 14000 rpm for 15 min at 4°C. The supernatant was then discarded. The pellet was washed with 300 µl 70% ethanol. The precipitation product was spun again and the supernatant was removed again. The pellet dried in the air and re-suspended in 10 µl sterile distilled water. The linearized plasmid was quantified and 0.1 µl was checked on DNA gel. The remaining linearized plasmid of 9.5 µl was then added into 50 µl competent SMD cells. Solution II of 1 ml was also added into 50 µl competent SMD cells. The cell mixture was incubated for one hour at 30°C with intermittent mixing-vortexing after every 15 minutes. The cells were then heat shocked in waterbath at 42°C for 10 mins. YPG of 2 ml was transferred in 15 ml falcon tube and the cell mixture was transferred to 2 ml YPG falcon tube. The cell mixture was incubated at 30°C for 2 hours to allow expression of the resistance against antibiotics and then centrifuged at 4000 rpm for 5 mins at room temperature. The supernatant was discarded and the pellet was washed with 1 ml solution III. This step was repeated. The cell pellet was then re-suspended in 100-150 µl solution III. The entire transformation was plated on YPG plate containing antibiotics and incubated for 3-4 days at 30°C. The positive clones were checked by using western blotting (see 2.5.7).

2.5.4 SDS-PAGE gel electrophoresis for proteins (>10 kDa)

Sodium dodecyl sulphate polyacrylamide gel electrophoresis (SDS-PAGE) was used to analyse stable protein samples (not suitable for small peptides), which was composed of 17.5% resolving gel (17.5% (v/v) acrylamide (National Diagnostics), 0.375 M Tris/HCl (pH 8.8), 0.1% (w/v) SDS, 0.2% (w/v) ammonium persulphate, 0.05% (v/v) TEMED (*N, N, N', N'*-tetramethylethylenediamine) and 2.5% stacking gel (2.5% (v/v) acrylamide, 0.125 M Tris/HCl (pH 6.8), 0.1% (w/v) SDS, 0.25%

(w/v) ammonium persulphate and 0.075% (v/v) TEMED). Protein samples were prepared to a final volume of 20 μ l with sterile distilled water. Then 5 μ l of 5x SDS sample buffer (312.5mM Tris-HCl pH 6.8, 50% (v/v) glycerol, 10% (w/v) SDS, 0.01% (w/v) Bromophenol blue, 2.5% (v/v) ammonium ethanol) was added to samples to make a total volume of 25 μ l. Samples were heated in boiling water or heat block for 10 minutes before loading into gel wells. SDS 7 molecular weight marker (Thermo Scientific) was used to determine protein sizes on gel (14.4 kDa, 18.4 kDa, 25 kDa, 35 kDa, 45 kDa, 66 kDa and 116 kDa). Prepared gels were run in 1x reservoir buffer (10x reservoir buffer: 0.25 M Tris-HCl, 1.92 M Glycine, 1% (w/v) SDS) at 100 V through the stacking gel, 150 V during going into resolving gel and 200 V through the resolving gel using an ATTO AE-6450 gel tank apparatus.

2.5.5 Tris-Tricine gel electrophoresis for small proteins or peptides (<10 kDa)

Tris-Tricine gels were prepared to analyse small proteins or peptides, which were composed of 15% separation gel (15% (v/v) acrylamide, filtered Tris-HCl/SDS buffer (1.0 M Tris, 0.1% (w/v) SDS, pH 8.45), 10.5% (v/v) glycerol, 0.2% (w/v) ammonium persulphate, 0.13% (v/v) TEMED and 4% stacking gel (4% (v/v) acrylamide, filtered Tris-HCl/SDS buffer (0.74 M tris, 0.74% (w/v) SDS, pH 8.45), 0.2% (w/v) ammonium persulphate, 0.12% (v/v) TEMED. Protein samples were prepared to a final volume of 20 μ l with sterile distilled water. Then 5 μ l of 5x SDS sample buffer (312.5mM Tris-HCl pH 6.8, 50% (v/v) Glycerol, 10% (w/v) SDS, 0.01% (w/v) Bromophenol blue, 2.5% (v/v) β -mercaptoethanol) was added to samples to make a total volume of 25 μ l. Samples were heated in boiling water for 10 minutes before loading into gel wells. Peptide molecular weight marker (Sigma) was used to determine protein sizes on gel (2.5 kDa, 6.2 kDa, 8.1 kDa, 10.7 kDa, 14.4 kDa and 16.9 kDa). Prepared gels were run in 1x Cathode buffer (upper buffer, 100 mM Tris-base, 100 mM tricine, 0.1% (w/v) SDS) and 1x Anode buffer (lower buffer, 20 mM tris-base pH 8.9) at 100 V through the stacking gel, 150 V under going into resolving gel and 200 V through the resolving gel using an ATTO AE-6450 gel tank apparatus.

2.5.6 SDS-PAGE gels staining with Coomassie Brilliant Blue and de-staining via de-staining buffer

After gel electrophoresis, proteins on the gel were visualised via staining with 0.04% (w/v) Coomassie Brilliant Blue G250 (CBB), in 7% (v/v) glacial acetic acid, 40% (v/v) methanol for 3-4 hours, then followed by de-staining with 7% (v/v) glacial acetic acid, 40% (v/v) methanol prepared in distilled water with gentle agitation until the blue colour background was gone. Staining and de-staining were carried out at room temperature with gentle agitation.

2.5.7 Western blot analysis

2.5.7.(i) Solutions required

The required solutions for western blot included Semi-dry transfer buffer (48mM Tris-HCl, 39mM Glycine, 20% Methanol), Ponceau S stain (0.5% Ponceau S, 1% Glacial acetic acid), 1L 10x PBS stock solution, Block solution (1x PBS, 0.05% Tween-20, 5% Milk powder), Primary antibody, Secondary antibody, Rinse solution (1x PBS, 0.05% Tween-20), Chemiluminescent detection solution A (1M Tris-HCl pH 8.5, 0.2mM Coumaric acid, 1.25mM Luminol) and Chemiluminescent detection solution B (5 μ l of 30% hydrogen peroxide with 45 μ l of purified water).

2.5.7.(ii) The protocol of western blot

Once SDS or Tris-Tricine protein gel run was completed, the gel was taken out of the tank. The stacking gel was then cut off. The resolving gel was then rinsed with distilled water. Resolving gel, six sheets of 3MM paper and one sheet of nitrocellulose membrane (Optitran BA-S 85 nitrocellulose membrane, Whatman Ltd.), which were cut to the same size as the resolving gel, were soaked for 10 minutes in semi-dry transfer buffer. These were then prepared in an ATTO blotting apparatus (Genetic Research Instrumentation Ltd.) according to the order: three sheets of 3MM paper, the nitrocellulose, the polyacrylamide gel and 3 additional sheets of 3MM paper again from bottom to top. Bubbles were removed by rolling a glass rod over the paper. Electroblothing was carried out at 0.15A, max V for 1 hour. Once finished, the nitrocellulose membrane was taken out of the ATTO blotting apparatus and was then soaked in Ponceau S stain for 1 minute in order to confirm the transfer and visualize the protein marker (the marker on the membrane was labelled with pencil for measuring the target protein size after blotting). Before

blocking the protein on the membrane, the Ponceau S stain was thoroughly rinsed in distilled water until the standard protein bands disappeared. For immunodetection, the nitrocellulose membrane was blocked for 1 hour at room temperature in 50 ml blocking buffer with shaking. The block buffer was renewed every 20 minutes. Then proteins on the nitrocellulose membrane were probed by using the primary antibody in 10 ml blocking buffer (1:3000 dilution) (supplied by Thermo Scientific or Cell Signalling Technology) and were incubated overnight at 4°C. On the second day, the primary antibody was washed off at room temperature in blocking buffer (the buffer was changed every 5 minutes for three times). The secondary antibody was used in 10 ml blocking buffer at a 1:5000 dilution and incubated with the membrane at room temperature for 2 hours followed by every 5 minutes wash in rinse solution for 3 times. The membrane was then thoroughly rinsed in distilled water. Chemiluminescent detection solution A (5 ml) and Chemiluminescent detection solution (15 µl) was mixed and poured onto one nitrocellulose membrane. After one minute, the membrane was put in the x-ray cassette for detection according to the manufacturer's instructions and proteins were visualized by exposure to X-ray film (Fuji SuperRX, Fuji Photo. Film Ltd.) The film was then developed using a Xograph Imaging Systems Compact X4 automatic developer.

2.5.8 Estimation of protein concentration

Amounts of unknown proteins were quantitatively estimated by BCA analysis using a BCATM Protein Assay Kit (Thermo Scientific) and BSA (Bovine serum albumin; 0.125-2mg ml⁻¹) as a standard protein. Concentrations of unknown protein were predicted using the standard curve. BCA reagent was prepared by mixing Solution B with Solution A (1:50) freshly before use. In microtitre plates 10 µl of water as blank, BSA standard or unknown sample was added to separate wells (in duplicate), respectively, and then mixed with 200µl of BCA Reagent. The plate was incubated for 30 minutes at 37°C. Absorbance was then measured at 562 nm using VeraMax ELISA microplate reader (Molecular Devices). For some pure protein samples, protein estimation was carried out by comparison to known amounts of GNA standards run on SDS-PAGE gels. Protein samples were loaded onto SDS-PAGE gel in different concentrations along with standard GNA amounts (GNA previously shown to be >95% homogeneous). The concentrations of the unknown

protein samples were determined from the known concentration of GNA standard protein bands.

2.5.9 Protein sequencing

Once SDS or Tris-Tricine protein gel run was completed, the dissolving gel was rinsed with distilled water and 10 mM CAPS (3-cyclohexylaamino-1-propane sulfonic acid) buffer (10 mM CAPS adjusted with 2 M NaOH to pH 11, 10% methanol), respectively. Six sheets of 3MM paper and one sheet of PVDF membrane (Boehringer GmbH, Germany), which were cut to the same size as the resolving gel, were soaked for 10 minutes in 10 mM CAPS transfer buffer. These were then prepared in an ATTO blotting apparatus (Genetic Research Instrumentation Ltd.) according to the order: three sheets of 3MM paper, the PVDF membrane, the polyacrylamide gel and 3 additional sheets of 3MM paper again from bottom to top. Bubbles were removed by rolling a glass rod over the paper. Electroblotting was carried out at 0.15A, max V for 1 hour. Once the transfer was finished, the PVDF membrane was taken out of the ATTO blotting apparatus and rinsed with 10% methanol for several seconds, then soaked in freshly prepared 0.1% coomassie Blue R250 in 40% methanol/1% acetic acid for 30 seconds in order to confirm the transfer. After being stained, the PVDF membrane was de-stained with 50% methanol until bands were visible and background was clear. Then the membrane was rinsed with distilled water waiting for protein N-terminal sequencing. Excised bands were supplied for N-terminal sequencing to a commercial protein sequencing service (Shanghai Applied Protein Technology Co., Ltd, China).

2.5.10 Proteins labeling with fluorescein isothiocyanate (FITC)

Firstly, the solution of a protein in 1x phosphate buffered saline (PBS) was labeled by mixing with equimolar concentrations of fluorescein isothiocyanate (FITC) (solution in dimethyl sulphoxide). Secondly, the reaction was incubated for 3 h in the dark at room temperature. Thirdly, the solution was dialyzed extensively against 1x PBS at 4 °C overnight to remove unbound FITC. Finally, the dialyzed protein/FITC was concentrated using a centrifugal concentrator and quantified by SDS-PAGE using GNA as standard protein. Protein/FITC could be visualized using fluorescence microscopy.

2.6 Large-scale production of spider recombinant insecticides and their fusion proteins in *Pichia pastoris*

2.6.1 Expression constructs of recombinant insecticides and fusion proteins

2.6.1.(i) Recombinant GNA protein construct

A highly expressing construct containing the mature GNA nucleotide sequence in pGAPZ α B was generated in our lab according to the reference from previous expression of recombinant GNA protein (Raemakers et al., 1999).

2.6.1.(ii) δ -Amaurobitoxin-P11a (P11a) and Ao1bPro-P11a constructs

The full-length nucleotide P11a toxin sequence (P83256) with codon usage optimised for yeast, which was inserted in the pUC57 vector incorporating *Pst*I and *Xba*I sites, was designed by the author and synthesized and supplied by ShineGene Molecular Biotech, Inc. (Shanghai 201109, China) (TA **CTGCAG** CA GGT TGT CTT GGT GAA GGT GAA AAG TGT GCT GAT TGG TCT GGT CCA TCT TGT TGT GAT GGT TTT TAC TGT TCT TGT AGA TCT ATG CCA TAC TGT AGA TGT AGA AAC AAC TCT **GC TCTAGA** AT). Plasmid DNA in PUC57 including the sequence of P11a gene was prepared using the Promega Wizard miniprep kit (Promega). P11a coding sequence was then transferred to the yeast expression vector pGAPZ α B (Invitrogen), which contains *myc* and (His)₆ tags, by digestion with *Pst* I and *Xba* I, isolation of the coding sequence fragment by agarose gel electrophoresis, followed by ligation to pGAPZ α B which had been restricted with the same enzymes. DNA fragments were separated by agarose gel electrophoresis prior to ligation, and were purified from excised gel slices using a QiaQuick Gel Extraction Kit (QIAGEN) as described in the manufacturer's protocol. After ligation, the resulting recombinant plasmid was cloned using standard protocols by transformation of electro-competent cells of *E. coli* (Sambrook and Russell, 2001). Selected clones were checked for correct assembly of the construct by DNA sequencing, followed by using Applied Biosystems ABI Prism 3730 automated DNA sequencers by DBS Genomics, School of Biological and Biomedical Sciences, Durham University, UK.

To produce the modified construct for expression of P11a, the full-length modified nucleotide encoding the Pro-region from U3- agatoxin-Ao1b (Q5Y4V7)

and P11a toxin sequence with codon usage optimised for yeast, which was inserted in the pUC57 vector incorporating *Pst*I and *Xba*I sites, was designed by the author and synthesized and supplied by ShineGene Molecular Biotech, Inc. (Shanghai 201208, China) (TA **CTGCAG CA** ATT TCT TAC GAA GAA GGT AAG GAA CTT TTT CAA AAG GAA AGA GGT TGT CTT GGT GAA GGT GAA AAG TGT GCT GAT TGG TCT GGT CCA TCT TGT TGT GAT GGT TTT TAC TGT TCT TGT AGA TCT ATG CCA TAC TGT AGA TGT AGA AAC AAC TCT **GC TCTAGA** AT). Generation of the expression construct encoding Ao1bPro-P11a was done according to the steps of P11a construct. Correct assembly of the construct (ProAo1b-P11a) was checked by DNA sequencing.

2.6.1.(iii) P11a/GNA, Ao1bPro-P11a/GNA, Hv1aPro-P11a/GNA and Mod-P11a/GNA constructs

The nucleotide sequence corresponding to mature P11a was PCR amplified to include *Pst*I and *Not*I sites using the PCR primers (Fwd P11a *Pst*I: 5' TA **CTGCAG CA** GGTTGTCTTGGTGAA and Rev P11a *Not*I: 5' AT **GCGGCCGC** AGAGTTGTTTCTACA). The resulting P11a PCR fragment was excised by digestion with *Pst*I and *Not*I, and purified by agarose gel electrophoresis as described above. A pGAPZ α B plasmid containing the fusion protein construct Hv1a/ GNA with (His)₆ tag only (Fitches et al., 2012) was digested with *Pst*I and *Not*I to remove the Hv1a coding sequence, and purified by agarose gel electrophoresis. The Hv1a coding sequence was then replaced by P11a by ligating the purified fragments to form P11a/GNA construct. Transformed *E. coli* colonies were used for colony PCR to select for positives and then DNA sequencing to ensure generation of a correct expression vector encoding the P11a/GNA fusion protein.

To produce the modified expression construct for P11a/GNA containing the Pro-region from U3-agatoxin-Ao1b, the nucleotide sequence corresponding to mature Ao1bPro-P11a was PCR amplified to include *Pst*I and *Not*I sites using the PCR primers (Fwd Ao1bPro-P11a *Pst*I: 5' TA **CTG CAG CA** ATTTCTTACGAAGAA and Rev Ao1bPro-P11a *Not*I: 5' AT **GCGGCCGC** AGAGTTGTTTCTACA). Then, the Ao1bPro-P11a/GNA expression construct was correctly assembled as described according to the steps of P11a/GNA construct.

To produce the modified expression construct for P11a/GNA containing the Pro-

region from ω -hexatoxin-Hv1a (Hv1a), the nucleotide sequence corresponding to the Pro-region of Hv1a was PCR amplified to include *Pst*I and *Pst*I sites using the PCR primers (Fwd Pro-region of Hv1a *Pst*I: 5' TA **CTGCAG** CA GAAGATACTAGAGCT and Rev Pro-region of Hv1a *Pst*I: 5' AT **CTGCAG** G TCTTCTAAAAACCTT). The resulting Hv1aPro-P11a PCR fragment was excised by digestion with *Pst*I and *Pst*I, and purified by agarose gel electrophoresis as described above. The pGAPZ α B plasmid containing the fusion protein construct P11a/ GNA with (His)₆ tag only was also digested with *Pst*I and purified by agarose gel electrophoresis. The purified Hv1aPro-P11a fragment was incorporated into linearised pGAPZ α B vector containing P11a/ GNA by restriction/ligation. Correct assembly of the construct (Hv1aPro-P11a/GNA) was checked by DNA sequencing.

To remove the glycosylation site on the mature P11a sequence, directed base site mutagenesis PCR was done according to the protocol 2.4.10. using the PCR primers (Fwd: TGTAGATGTAGACAAAACCTCTGCGGCCGC and Rev: GTATGGCATAGATCTACAAGAACAGTAAA). Then the Modified P11a/GNA (Mod-P11a/GNA: amino acid N to amino acid Q Mutation) expression construct containing the de-glycosylated mature P11a sequence (**CTGCAG** CA GGT TGT CTT GGT GAA GGT GAA AAG TGT GCT GAT TGG TCT GGT CCA TCT TGT TGT GAT GGT TTT TAC TGT TCT TGT AGA TCT ATG CCA TAC TGT AGA TGT AGA **CAA AAC TCT GCGGCCGC**) was checked by DNA sequencing.

2.6.1.(iv) Hv1a, Pro-Hv1a and Pro-Hv1a/GNA constructs

The nucleotide sequence corresponding to mature Hv1a was PCR amplified to include *Pst*I and *Xba*I sites using the PCR primers (Fwd Hv1a *Pst*I: 5' TA **CTGCAG** CA TCTCCAACCTTGTATT and Rev Hv1a *Xba*I: 5' AT **TCTAGA** GC ATCACATCTCTTAAC). The resulting Hv1a PCR fragment was excised by digestion with *Pst*I and *Xba*I, and purified by agarose gel electrophoresis as described above. A pGAPZ α B plasmid containing the construct P11a was digested with *Pst*I and *Xba*I to remove the P11a coding sequence, and purified by agarose gel electrophoresis. The P11a coding sequence was then replaced by Hv1a by ligating the purified fragments to form Hv1a construct. Transformed *E. coli* colonies were used for colony PCR to select for positives and then DNA sequencing to ensure generation of a correct expression vector encoding the recombinant Hv1a protein.

The full-length nucleotide Pro-Hv1a toxin sequence with codon usage optimised for yeast, which was inserted in the pUC57 vector incorporating *Pst*I and *Xba*I sites, was designed by the author and synthesized and supplied by ShineGene Molecular Biotech, Inc. (Shanghai 201109, China) (TA **CTGCAG** CA GAA GAT ACT AGA GCT GAT CTT CAA GGT GGT GAA GCT GCT GAA AAG GTT TTT AGA AGA TCT CCA ACT TGT ATT CCA TCT GGT CAA CCA TGT CCA TAC AAC GAA AAC TGT TGT TCT CAA TCT TGT ACT TTT AAG GAA AAC GAA AAC GGT AAC ACT GTT AAG AGA TGT GAT **GC TCTAGA** AT). Plasmid DNA including the coding sequence of Pro-Hv1a gene was prepared using the Promega Wizard miniprep kit (Promega). Pro-Hv1a coding sequence was then transferred to the yeast expression vector pGAPZ α B by digestion with *Pst*I and *Xba*I, followed by ligation to pGAPZ α B, which had been restricted with the same enzymes. DNA fragments were separated by agarose gel electrophoresis prior to ligation, and were purified from excised gel slices using a QiaQuick Gel Extraction Kit as described in the manufacturer's protocol. After ligation, the resulting recombinant plasmid was cloned using standard protocols by transformation of electro-competent cells of *E. coli*. Selected clones were checked for correct assembly of the construct by DNA sequencing via Applied Biosystems ABI Prism 3730 automated DNA sequencers by DBS Genomics, School of Biological and Biomedical Sciences, Durham University, UK.

The nucleotide sequence corresponding to mature Pro-Hv1a (native Pro-region) was PCR amplified to include *Pst*I and *Not*I sites using the PCR primers (Fwd Pro-Hv1a *Pst*I: 5' TA **CTGCAG** CA GAAGATACTAGAGCT and Rev Pro-Hv1a *Not*I: 5' AT **GCGGCCGC** ATCACATCTCTTAAC). The resulting Pro-Hv1a PCR fragment was excised by digestion with *Pst*I and *Not*I, and purified by agarose gel electrophoresis as described above. A pGAPZ α B plasmid containing the fusion protein construct Hv1a/ GNA with (His)₆ tag only was digested with *Pst*I and *Not*I to remove the Hv1a coding sequence, and purified by agarose gel electrophoresis. The Hv1a coding sequence was then replaced by Pro-Hv1a by ligating the purified fragments to form Pro-Hv1a /GNA construct. Transformed *E. coli* colonies were subject to colony PCR to select for positives and then DNA sequencing to ensure generation of a correct expression vector encoding the Pro-Hv1a /GNA fusion protein.

2.6.1.(v) Ec2a/GNA and Pro-Ec2a/GNA constructs

The nucleotide sequence corresponding to mature κ -TRTX-Ec2a (Ec2a) was PCR amplified to include *Pst*I and *Not*I sites using the PCR primers (Fwd Ec2a *Pst*I: 5' TA **CTGCAG CA** TACTGTCAAAAGTTT and Rev Ec2a *Not*I: 5' AT **GCGGCCGC** CTTTTCCAACCTTACA). The resulting Ec2a PCR fragment (**CTGCAG CA** TAC TGT CAA AAG TTT TTG TGG ACT TGT GAT ACT GAA AGA AAG TGT TGT GAA GAT ATG GTT TGT GAA TTG TGG TGT AAG TTG GAA AAG **GCGGCCGC**) was excised by digestion with *Pst*I and *Not*I, and purified by agarose gel electrophoresis as described above. A pGAPZ α B plasmid containing the fusion protein construct Hv1a/ GNA with (His)₆ tag only was digested with *Pst*I and *Not*I to remove the Hv1a coding sequence, and purified by agarose gel electrophoresis. The Hv1a coding sequence was then replaced by Ec2a by ligating the purified fragments to form Ec2a/GNA construct. Transformed *E. coli* colonies were subject to colony PCR to select for positives and then DNA sequencing to ensure generation of a correct expression vector encoding the Ec2a/GNA fusion protein.

To produce the modified construct for expression of Pro-Ec2a (the Pro-region from toxin-like peptide of *Grammostola rosea*, which is highly homologous with Ec2a), the full-length of Pro-Ec2a toxin sequence with codon usage optimised for yeast, which was inserted in the pUC57 vector incorporating *Pst*I and *Xba*I sites, was designed by the author and synthesized and supplied by ShineGene Molecular Biotech, Inc. (Shanghai 201305, China) (TA **CTG CAG CA** TTG GAA GAG CAA GAC CAC CTT TCT TTG CGT AAT GAT CTA CTA ACA GTT ATG TTT GCG GAG AAC TAC TGT CAA AAG TTT TTG TGG ACT TGT GAT ACT GAA AGA AAG TGT TGT GAA GAT ATG GTT TGT GAA TTG TGG TGT AAG TTG GAA AAG **GC TCTAGA** AT). To produce the modified expression construct for Pro-Ec2a/GNA, the nucleotide sequence corresponding to mature Pro-Ec2a was PCR amplified to include *Pst*I and *Not*I sites using the PCR primers (Fwd Pro-Ec2a *Pst*I: 5' TA **CTG CAG CA** TTG GAA GAG CAA GAC CAC and Rev Pro-Ec2a *Not*I: 5' AT **GCGGCCGC** CTTTTCCAACCTTACACCA). Then, the Pro-Ec2a/GNA expression construct was correctly assembled as described according to the steps of making Ec2a/GNA construct.

2.6.2 Transformation of recombinant protein expression constructs in *P. pastoris*

pGAPZ α plasmids containing recombinant protein expression constructs were amplified in *E. coli*, purified and linearized with *BlnI*. Linearised plasmids of 5 μ g were transformed into *P. pastoris* strain SMD1168H (Invitrogen) using the EasyComp Transformation kit (Invitrogen) as described in the manufacturer's protocol. The completely digested DNA was purified from the agarose gel and then ethanol precipitated overnight. Then the linear DNA was re-suspended in 10 ml sterile distilled water for yeast transformation. Transformed yeast clones were plated and selected on YPG agar plates containing zeocin (100 mg/ml) and incubated for 3-5 days at 30 °C room. Colonies (at least 12 for each construct) were then streaked out onto freshly made selective YPG media plates containing zeocin for growing.

2.6.3 Expression and western blot detection of transformed *P. pastoris* colonies

The YPG mediums of 10ml containing 100mg/ml zeocin were inoculated with the transformed colonies in McCartney bottles. They were allowed to grow at 30°C on an orbital shaker at 220 rpm for 3 days. The cultures were then subjected to centrifugation at room temperature at 4000x g for 15 minutes. Each 25 μ l sample of culture supernatant was then separated by SDS-PAGE electrophoresis. The gel was blotted onto nitrocellulose and probed with anti-(His)₆ primary antibodies (Bio-Rad) or anti-GNA primary antibodies, followed by washing, probing with HRP-conjugated secondary antibodies (Bio-Rad), and detection of bound antibodies by ECL, as described previously (Fitches and Gatehouse, 1998). Each 650 μ l of overnight culture of detected positive clone was added to 350 μ l sterile 60% (v/v) glycerol in sterile cryovials and mixed. Cryovials were subsequently frozen in liquid nitrogen and transferred to -80°C for long-term storage.

2.6.4 Large-scale expression (fermentation) of recombinant proteins in *P. pastoris*

For large-scale expression of all recombinant fusion proteins stated above, three 100ml starter cultures of YPG media without any antibiotics, inoculated with transformed *P. pastoris* cells, were grown at 30°C for 3 days using an orbital shaker

at 220 rpm. These cultures were then used for inoculating 2.5 L of sterile minimal media supplemented with PTM1 salts growing in either a 7.5L BioFlo 110 bench-top fermenter (New Brunswick Scientific) or a 5 L Bio-Controlly ADI1010 bench-top fermenter (APPLIKON BIOTECHNOLOGY, Holland). Cultivation at 30°C, 30% dissolved oxygen, pH 4.5-5.0 with continuous agitation was carried out with a ramped glycerol feed (5-10 ml/h) over a period of 4 days (Fitches et al., 2004).

2.6.5 Purification of recombinant proteins

2.6.5.(i) Purification of recombinant proteins by nickel affinity chromatography

Culture supernatant was subsequently separated from cells by centrifugation (20 minutes, 8000 rpm; 4°C) using a Beckman J-Lite rotor and a Beckman Coulter centrifuge, clarified by filtration through 2.7 µm and 0.7 µm glass fibre filters (GFD and GFF; Whatmann). Supernatants were adjusted to 0.02 M sodium phosphate buffer, 0.4 M sodium chloride, pH 7.4 by adding 4x concentrated stock (4X Binding buffer (BB)). Recombinant proteins were purified by nickel affinity chromatography on 5 ml HisTrap crude nickel columns (GE Healthcare) with a flow rate of 2 ml/min. After loading, the columns were washed with 1x BB (50 mM sodium phosphate; 0.4 M sodium chloride) and then with 1x BB containing 0.025 M imidazole, and finally bound recombinant proteins were eluted with 1x BB containing 0.2 M imidazole. In all cases eluted proteins were then analysed by SDS-PAGE gel electrophoresis and western blot to check for purity and establish which fractions contained the target recombinant proteins.

2.6.5.(ii) Purification of recombinant proteins by gel filtration chromatography

Freeze-dried protein samples after dialysis from peak fractions, such as recombinant Ao1bPro-P11a protein sample, which still contained some yeast proteins after nickel affinity chromatography, was re-suspended in 1x PBS at a concentration of 2mg/ml. Ao1bPro-P11a protein solution was loaded onto a Sephacryl S-200 (Amersham) column (matrix was filled with 20% ethanol) to separate the pure Ao1bPro-P11a protein from yeast proteins. Before loading, the column was washed with 2 to 5-column volume distilled water. Then the column was equilibrated in 2 to 5-column volume 1x PBS.

2.6.6 Dialysis and freeze-drying of recombinant proteins

Dialysis was carried out using dialysis tubing with a molecular weight cut off of 2kDa (SIGMA-ALDRICH Ltd.), 8kDa (Medicell International Ltd.) and 12-14kDa (Medicell International Ltd.) respectively, according to the molecular weight of proteins. These dialysis tubes were prepared by boiling for ten minutes in purified water containing 5mM ammonium hydrogen carbonate and a trace of EDTA. Protein fractions pooled from chromatograph peaks were dialysed against deionised water using multiple changes (including one change of overnight) to remove all small molecules at 4°C. Dialysed protein solutions were then snap-frozen in liquid nitrogen followed by vacuum freeze-drying using a Flexi-Dry microprocessor control corrosion resistant freeze-dryer until the samples had lyophilized. Samples were subsequently stored at 4°C. Concentrations of recombinant proteins were estimated by comparison to known amounts of GNA standards run on SDS-PAGE gels or by BCA analysis using a BCATM Protein Assay Kit (Thermo Scientific).

2.6.7 Insect pest bioassays

2.6.7.(i) *Mamestra brassicae* injection bioassays

Injection bioassays were carried out using 4-5th stadium *M. brassicae* larvae (approx. 45-55mg in weight) by injecting 5ul of aqueous solution containing varying doses of recombinant proteins dissolved in 1×PBS (phosphate buffered saline; 0.15M NaCl, 0.015M sodium-phosphate buffer, pH 7.2). Controls were injected with 5ul 1×PBS. For each dose, 30 larvae were injected and paralysis and mortality were scored at 12, 24, 36, 48, 60 and 72 h post injection including control.

2.6.7.(ii) *Musca domestica* injection bioassays

Adults of *M. domestica* were injected with 1.0ul of aqueous solution containing varying doses of recombinant proteins dissolved in 1×PBS, using a conventional Hamilton syringe with a fine needle. Two kinds of controls were monitored including negative control with 1×PBS and positive control with proteins from yeast dissolved in 1×PBS. Survival was monitored over a 144h period.

2.6.7.(iii) *Mamestra brassicae* drop-feeding bioassays

Droplet-feeding assays were conducted to assess the oral activity of fusion proteins towards *M. brassicae* third to sixth instar larvae. Larvae were fed once with a 2µl droplet containing 20 or 30µg of fusion proteins, 30µg of recombinant toxins only, or 30µg of GNA only in 1 x PBS and 10% sucrose. Smaller larvae were exposed to the droplet repeatedly until they finished the 2µl droplet. Control larvae were fed on droplets containing 1 x PBS and 10% sucrose solution. Treated larvae were placed in ventilated plastic pots (250 ml) with standard artificial diet after consumption of the droplet. To encourage droplet consumption, larvae were starved for approx. 24 h prior to feeding. Larval weight and survival was recorded daily after droplet feeding. In experiments to show effects of fusion proteins on feeding, the artificial diet was weighed prior to introduction and re-weighed on removal to determine the amount consumed. Artificial diets were replaced daily.

2.6.7.(iv) *Musca domestica* drop-feeding bioassays

In feeding assays, adult flies were allowed to feed from cotton pads, which had been soaked in the solution of P11a/GNA in 20% or 60% sucrose; survival was monitored over a 120h period in which flies were exposed continuously to the treatment.

2.6.7.(v) Cereal aphid (*Sitobion avenae* F.) and pea aphid (*Acyrtosiphon pisum*) drop-feeding bioassays

The toxicity of proteins to aphids *A. pisum* and *S. avenae* (F.) was determined by bioassay using a liquid artificial diet (Douglas and Prosser, 1992; Prosser and Douglas, 1992), using a parafilm sachet to deliver diet to insects. Proteins were dissolved in sterile diet at known concentrations. The standard assay used 1-2 day-old aphid nymphs, which had been conditioned by transfer to diet without added proteins prior to receiving the protein treatments, was continued until the insects became mature. Effects of treatments on aphid growth were assessed by using Image J Software to measure insect length.

2.6.7.(vi) Drop-feeding bioassays of pyrethroid-resistant peach-potato aphid (*Myzus persicae*)

Bioassay of aphids using liquid artificial diet was carried out as described above. Adult aphids were transferred to control liquid diet, acclimatised for 24h, and then neonate nymphs produced over the following 24h were transferred to experimental diets, and allowed to develop to adult stage (8-9 days). Individuals of 20 per treatment were used to perform the bioassays. Each assay was repeated 3 times. Mortality was observed daily, and assays were continued until control aphids started to produce nymphs. The presence or absence of progeny was recorded. Effects of treatments on aphid growth were assessed by using Image J Software to measure insect length.

2.6.7.(vii) Injection bioassays: *Deroceras reticulatum* (mollusc grey field slug)

Recombinant fusion proteins were tested for activity against adult slugs (*Deroceras reticulatum*) by injection into adult slugs (0.2 – 0.3 g). Slugs were chilled at 4°C (for approximately 15 minutes) prior to injection of 25 µg, 50 µg or 100 µg of purified fusion proteins re-suspended in 20 µl 1x PBS. Two kinds of controls were monitored including negative control with 1xPBS and positive control with proteins from yeast dissolved in 1xPBS. Mortality was assessed daily for 7 days.

2.6.8 Total protein extraction from the gut, haemolymph, Malpighian tubules, fat body and nerve chord of *M. brassicae*

M. brassicae larvae were injected or fed a single dose of each fusion protein. After 2h, 4h, 6h, 20h, 24h and 48h, respectively, *M. brassicae* tissues were dissected by using the dissecting microscope in 0.9% saline and were rinsed with protein extraction buffer (50mM HEPES (4-(2-hydroxyethyl)-1-piperazineethanesulfonic acid), 0.1% Triton-X100 pH 6.4). Tissues were then homogenised in 200 µl 1x PBS buffer with incubated at 4°C for 1 hour and then centrifuged at 14000 rpm at 4°C for 10 minutes. Total proteins in the supernatant of each tissue were analysed by BCA quantification using a BCATM Protein Assay Kit (Thermo Scientific). Then 25 µl solution containing 1 µg total protein and 5 µl sample buffer from gut contents, haemolymph, Malpighian tubules, fat body and nerve chord, respectively, was visualised by SDS-PAGE analysis, followed by western blotting using anti-GNA antibodies.

2.6.9 Detecting binding of recombinant proteins to aphid gut surface

To demonstrate binding of proteins to the aphid gut surface, recombinant fusion proteins were labelled by conjugation with fluorescein, and fed to aphids at a sub-lethal concentration for 24h. The label was then “chased” by allowing aphids to feed on control diets for 24 h and 48 h. Labelled proteins were detected in whole insects by fluorescence microscopy (green channel; excitation at 490 nm, detection at 525 nm), and were readily detectable in insects with no chase after feeding. Aphids fed on the diet containing 0.1 mg/ml Propidium iodide as a standard DNA stain to localize the gut tissue (visualised using fluorescence microscopy; red channel; excitation at 488 nm, detection using 562–588 nm filter).

2.7 Construction of plasmids containing GL-Pro-Hv1a-GNA and generation of transgenic Arabidopsis

All previously made constructs for use as templates were supplied as glycerol stocks by Dr. Emma Jane Back, Durham University. Ligation reactions were all transformed into TOP 10 electrocompetent *E. coli* cells and positive colonies were determined by DNA sequencing.

2.7.1 Pro-Hv1a/GNA based expression constructs

The nucleotide sequence corresponding to Pro-Hv1a was PCR amplified to include *Pst*I and *Xba*I sites using the PCR primers (Fwd Pro-Hv1a *Pst*I: 5' TA **CTGCAG** CA GAAGATACTAGAGCT and Rev Pro-Hv1a *Xba*I: 5' AT **TCTAGA** GC ATCACATCTCTTAAC). The resulting Pro-Hv1a PCR fragment was excised by digestion with *Pst*I and *Xba*I, and purified by agarose gel electrophoresis as described above. A pGAPZ α B plasmid containing the construct of GNA leader signal sequence (GL)+Hv1a+GNA ((obtained from Dr. Emma Jane Back, Durham University) was digested with *Pst*I and *Xba*I to remove the Hv1a coding sequence, and purified by agarose gel electrophoresis. The Hv1a coding sequence was then replaced by Pro-Hv1a by ligating the purified fragments, and cloning the resulting recombinant plasmid to form construct GL-Pro-Hv1a-GNA. Transformed *E. coli* colonies were subject to colony PCR to select for positives and then DNA sequencing to ensure generation of a correct expression vector encoding the recombinant Pro-Hv1a/GNA fusion protein in Arabidopsis.

2.7.2 Cloning GL-Pro-Hv1a-GNA construct into plant expression vectors using the Gateway™ cloning system

2.7.2.(i) Subcloning GL-Pro-Hv1a-GNA construct into entry vector pENTR™/D-TOPO

To generate an entry clone by which the GL-Pro-Hv1a-GNA construct could enter the GATEWAY™ system (Invitrogen), GL-Pro-Hv1a-GNA was PCR amplified with appropriate primers containing CACC in the 5' primer termini and ligated into pENTR D-TOPO (Invitrogen) using oligonucleotides (5' FWD: CACCATGGCTAAGGCAAGTCTCCTC and 3' REV: GAAATCATCCAGTAGCCCAACGATC). Purified PCR products (<200 ng DNA) were ligated into pENTR D-TOPO using TOPO directional cloning based on the manufacturer's instructions. Ligation reactions contained 4 µl PCR product, 1 µl salt solution (Invitrogen), 1 µl pENTR D-TOPO vector (Invitrogen) and sterilised distilled water to a final volume of 6 µl. pENTR D-TOPO ligation reactions were incubated at 22°C for 30 minutes then transformed (2 µl ligation) into *E. coli*.

2.7.2.(ii) Generation of an expression vector containing GL-Pro-Hv1a-GNA fragment

The LR recombination reaction of the Gateway cloning system was used to generate an expression vector in Arabidopsis. The destination vectors pEarlyGate 100 were used in this reaction along with the entry vector pENTR D-TOPO containing GL-Pro-Hv1a-GNA. Recombination reactions containing 5µl (50-150 ng) entry plasmid, 2µl destination vector (150ng/µl), 1µl TE buffer (PH 8.0) were thawed on ice. Then 2µl LR clonase enzyme mix (Invitrogen) was added into the reactions. Mixed solutions were incubated at 25°C for 1 hour then inactivated by the addition of 1 unit Proteinase K (Invitrogen) for 10 minutes at 37°C. Recombination reactions (1µl) were transformed into *E. coli*. Successful transformed colonies were checked by colony PCR DNA sequencing.

2.8 Generation of transgenic Arabidopsis lines

2.8.1 Transformation of pEarlyGate 100 plasmid containing GL-Pro-Hv1a-GNA into Arabidopsis using *Agrobacterium tumefaciens* system

Competent cells of *Agrobacterium* strain GV3101 (obtained from Dr. Cunjin Zhang, Durham University) were thawed on ice. The plasmid DNA of 1µg was added to the cells and incubated on ice for 5 minutes. Then the cells containing DNA were put into liquid nitrogen for 5 minutes and incubated at 37°C (water bath) for another 5 minutes. 1 ml of LB medium was added immediately to the cells which were then transferred to an eppendorf and incubated for 2 hours at 28°C with shaking (200 rpm). Transformed cells were plated out on LB agar containing rifampicin (50µg/ml), gentamicin (25µg/ml) and kanamycin (50µg/ml) for the transformed plasmid. Plates were incubated at 28°C for 48h until colonies appeared.

2.8.2 Arabidopsis growth conditions

Arabidopsis thaliana seeds of the Col-0 ecotype (obtained from Dr. Cunjin Zhang, Durham University) were sown in 4'' plastic pots and covered for a 2-day period to break dormancy. Plants were grown in a growth room under a 16-hour photoperiod (16 hours light, 8 hours darkness) until flowering (5-6 weeks). First bolts were cut to reduce apical dominance and promote internodal growth (Back, Ph.D. thesis; unpublished data).

2.8.3 Transformation by floral dipping

Cells from a single colony of *Agrobacterium* GV3101 with the plasmid containing GL-Pro-Hv1a-GNA were inoculated into a 10 ml overnight culture of LB media with rifampicin (50 µg/ml), gentamicin (25 µg/ml) and kanamycin (50 µg/ml) at 220 rpm. Following overnight growth at 28°C, 220 rpm, 10 mls of culture was used to inoculate 500 mls of LB media containing rifampicin (50 µg/ml), gentamicin (25 µg/ml) and kanamycin (50 µg/ml) until a final OD₆₀₀ was 0.6-0.8. Cells were pelleted by centrifugation at 2500 g for 10 minutes and re-suspended in Infiltration medium (5% w/v sucrose, 0.03% v/v Silwet L-77). Arabidopsis plants above soil were put upside down and fully immersed in infiltration media and gently agitated for 10-15 seconds. Four pots containing 2 plants per pot were dipped for transformation. Dipped plants were covered with black sealed bags and placed in a shaded position for 24 h following normal growth conditions for 2-3 weeks.

2.8.4 Seed collection

Harvested seeds were allowed to dry out for up to 2 weeks at room temperature before storing at 4°C.

2.8.5 Seed sterilisation

Seeds were first washed in 1 ml 70% ethanol for 1-2 minutes and then centrifuged at 8000 x g for 2 minute to spin down. Secondly, the supernatant was removed and 1 ml of sterilisation solution was added into the seeds precipitation with proper vortexing for 10 minutes. Thirdly, the seed solution was centrifuged again and supernatant was removed. Fourthly, the seeds were mixed with 1ml of sterilised distilled water and then were vortexed for 1 minute and centrifuged, which step was repeated at least 5 times to make sure that all the sterilisation solution was removed.

2.8.6 Screen for homozygous transformed *Arabidopsis* lines

T₁ seed from transformed *Arabidopsis* plants after Basta (Chemical name: glufosinate ammonium) selection was selected with 20µg/ml basta on 0.8% Phyto agar (Duchefan SKU: P1003), 0.5 x Murashige and Skoog (MS) media (1962) plates containing basta antibiotics. Negative plants without basta resistance died with leaves turning yellow. When T₂ generation seeds (3:1 segregation) on antibiotic selection were selected, independent homozygous T₃ plant lines were selected from plants demonstrating 100% antibiotic resistance. The lines were then used in bioassay experiments.

2.9 Analysis of transformed plants

2.9.1 Extraction of total protein from leaf tissues

Single leaves were placed in 1.5ml eppendorf tubes and flash frozen in liquid nitrogen before being ground to a fine powder. Plant tissue samples (approx 1 g wet weight) were ground with chilled protein extraction buffer (50 mM Tris-HCl pH 8.0, 1 mM EDTA, 150 mM NaCl, 10% (v/v) Glycerol, 5 mM DTT and 0.1% (v/v) Triton x100) until a good mixed solution was got. Then samples were subjected to

centrifugation for 10 minutes at 12000 rpm and 4°C. The supernatant was removed and quantified by BCA analysis.

2.9.2 Analysis of protein expression by western blotting

Positive clones of the Arabidopsis with functional expression of fusion proteins were confirmed by western bolt using anti-GNA antibodies (as described in section 2.5.7). Recombinant GNA protein was used as a standard at 50 ng and 100 ng concentrations. All samples were loaded on the basis of 8 µg total solution protein. A negative control was also included using protein extracted from untransformed wild type Arabidopsis plants.

CHAPTER 3 EXPRESSION OF RECOMBINANT SPIDER INSECTICIDAL NEUROTOXINS AND THEIR FUSION PROTEINS

Introduction

Venoms isolated from a range of arachnids have been shown to contain proteins, which are biologically active toxins when injected into potential prey. Most are small proteins, in the range 30-70 amino acid residues (variously referred to as peptides or proteins), that principally target neuronal ion channels, and to a lesser extent neuronal receptors and presynaptic membrane proteins, to cause paralysis of the prey (Rash and Hodgson, 2002). As a result of evolutionary selection, some toxins combine a high toxicity for insects with no effects on members of other taxons (Vassilevski et al., 2009). The potency and selective mode of action of spider neurotoxins makes them ideal candidates for use in environmentally compatible pest management technologies by fusing them with GNA (Fitches et al., 2002; Whetstone and Hammock, 2007). Peptide/GNA fusion proteins possess good stability, so they are hard to be degraded in the environment or digested by gut enzymes of pests. They also have high toxicity, with activity towards pests comparable to the toxin proteins themselves (Fitches et al., 2012; Yang et al., 2014a). Moreover, Pro-regions of spider toxins (which vary from around 40 to 550 amino acids) also help to direct folding of proteins (Chapter 1). Therefore, the expression of a toxin or a fusion protein by addition of its predicted Pro-region sequence in the expression construct may be able to improve its biological activity.

The present chapter reports the production and purification of some small spider cysteine-rich protein toxins as insecticides including δ -amaurobitoxin-P11a (P11a) from tangled nest spider (*Pireneitega luctuosa*), U1-cyrtautoxin-As1c (As1c) isolated from *Apomastus schlingeri* (Trap-door spider), ω -atracotoxin-Hv1a (Hv1a) from funnel web spider (*Hadronyche versuta*) and κ -theraphotoxin-Ec2a (Ec2a) from *Eucratoscelus constrictus*, which target insect voltage-gated sodium channels, channels unknown, voltage-gated calcium channels and calcium-activated potassium

(BK_{Ca}) channels, respectively. These toxins were produced as fusion proteins by combining with the coding sequences of snowdrop lectin GNA ("carrier") that have the function to deliver these toxins to the central nervous system of the target pest using the yeast *P. pastoris* as an expression host.

3.1 Construction of recombinant P11a and Ao1bPro-P11a toxins; P11a/GNA, Ao1bPro-P11a/GNA and Hv1aPro-P11a/GNA fusion proteins; recombinant Hv1a and Pro-Hv1a toxins; Hv1a/GNA and Pro-Hv1a/GNA fusion proteins; recombinant As1c toxin and As1c/GNA fusion protein; Ec2a and Pro-Ec2a toxins; Ec2a/GNA and Pro-Ec2a/GNA fusion proteins

Expression constructs for production of recombinant proteins in the methylotrophic yeast *P. pastoris* were based on the vector pGAPZαB, which contains a strong constitutive promoter used to direct expression of the recombinant protein, and which is designed to integrate into the host genome at the *GAPDH* locus, giving stable transformants. The expression constructs for production of recombinant toxins and their fusion proteins were introduced in Chapter 2. The diagrammatic representations of constructs and predicted sequences of recombinant toxins and their fusion proteins were shown in figures (Fig 3.1A and Fig 3.2A; Fig 3.1B and Fig 3.2B; Fig. 3.3 A, B and C; Fig. 3.4 A, B and C; Fig. 3.5 A, B, C and D; Fig. 3.6 A, B, C and D; Fig. 3.7 A and B; Fig. 3.8 A and B; Fig. 3.9 A, B, C and D; Fig 3.10 A, B, C and D). The constructs were assembled by restriction-ligation and were checked by DNA sequencing after cloning.

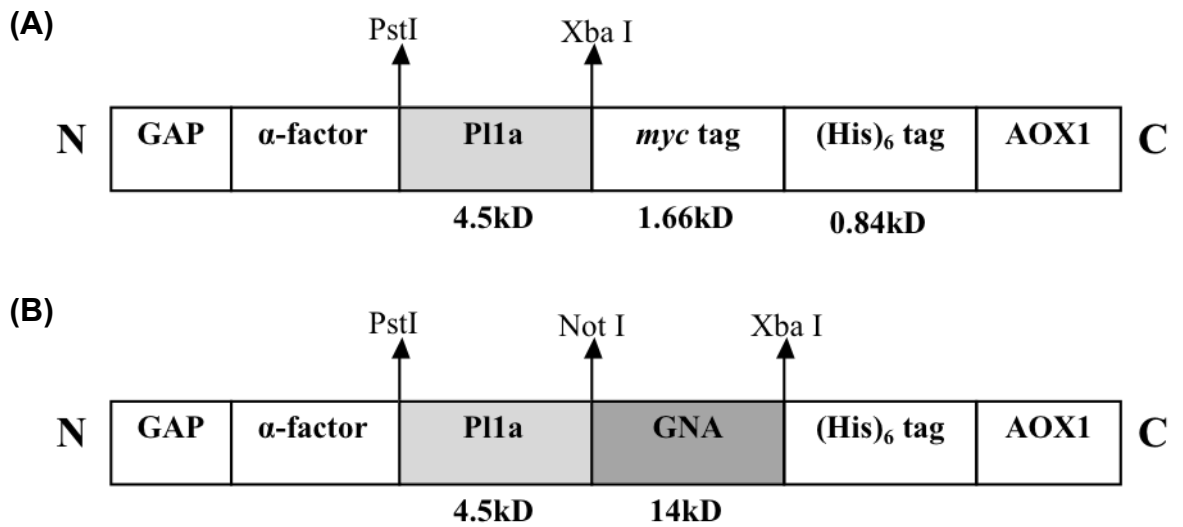

Figure 3.1

Diagrammatic representation of PI1a (A) and PI1A/GNA (B) constructs with restriction sites integrated into pGAPZ α B, respectively. The position of the pGAPZ α B N-terminal (GAP promoter region and α -factor signal sequence) and C-terminal (*myc* epitope, (His)₆ tag and AOX1 transcription termination region) are shown in the figure.

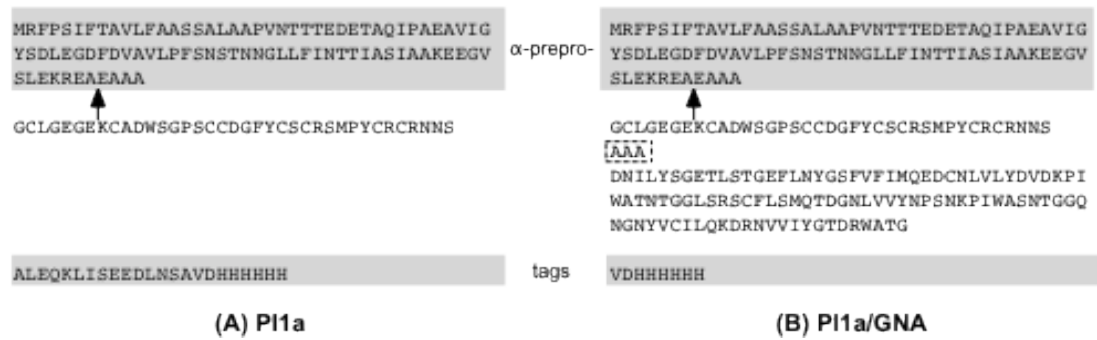

Figure 3.2

Sequences of predicted products from expression constructs for P11a toxin (A) and P11a/GNA fusion protein (B). Shaded regions indicate sequence provided by the vector; the cleavage point for removal of the yeast α -factor prePro-sequence is indicated by an arrow. Dotted box in (B) indicates the "linker" sequence contributed by the nucleotides used to join the P11a and GNA coding sequences together.

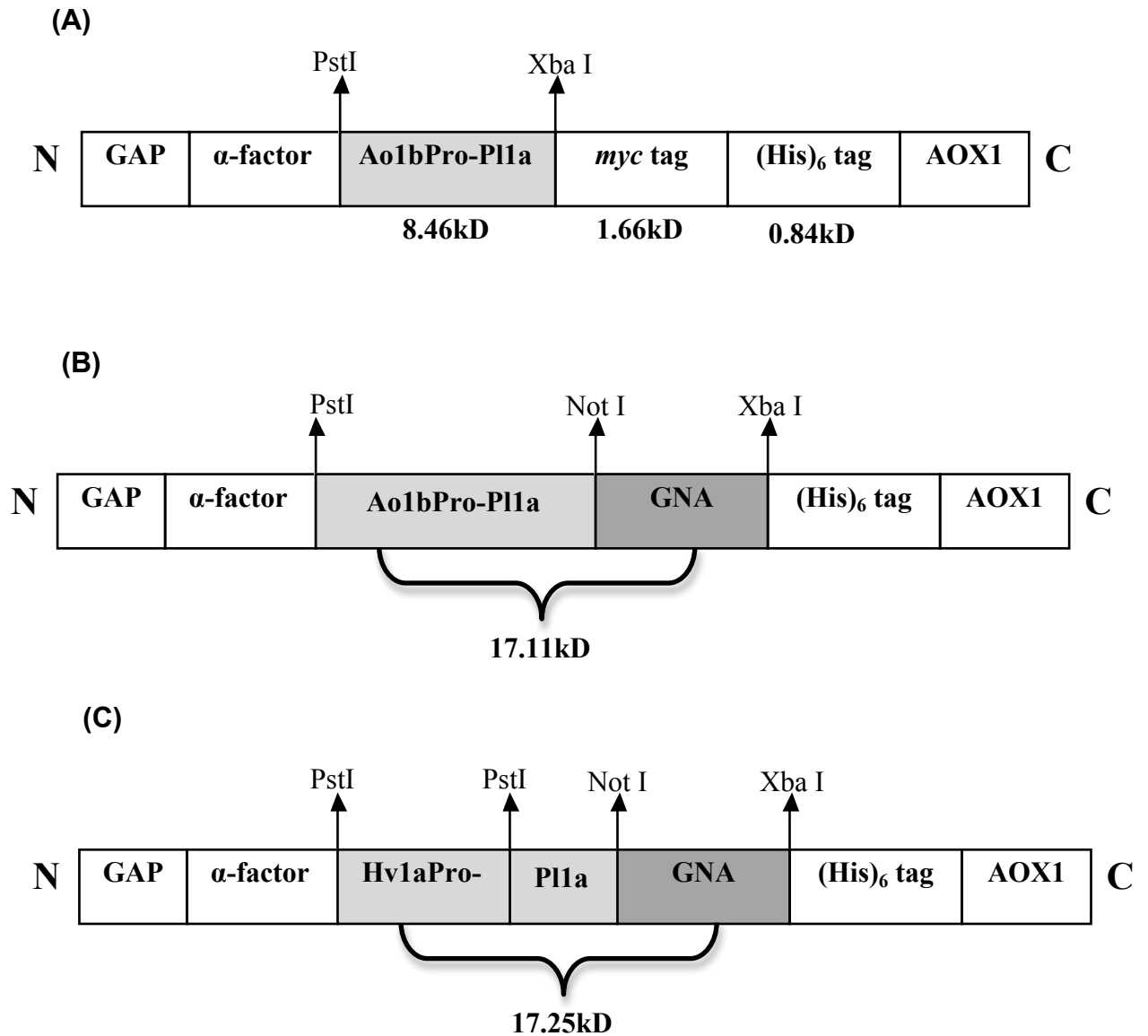

Figure 3.3

Diagrammatic representation of recombinant Ao1bPro-PI1a (A), Ao1bPro-PI1a/GNA (B), and Hv1aPro-PI1a/GNA (C) constructs with restriction sites integrated into pGAPZ α B, respectively. The position of the pGAPZ α B N-terminal (GAP promoter region and α -factor signal sequence) and C-terminal (*myc* epitope, histidine tag and AOX1 transcription termination region) are shown in the figure.

(A)

MRFPSIFTAVLFAASSALAAPVNTTTEDETAQIPAEAVIGYSDLEGDFD
VAVLPFSNSTNNGLLFINTTASIAAKEEGVSLEKREAEAAAI SYEEGKE
LFQKERGCLGEGEKCADWSGPSCCDGYCSCRSMPYCRCRNNSALEQK
LISEEDLNSAVDHHHHHH

(B)

MRFPSIFTAVLFAASSALAAPVNTTTEDETAQIPAEAVIGYSDLEGDFD
VAVLPFSNSTNNGLLFINTTASIAAKEEGVSLEKREAEAAAI SYEEGKE
LFQKERGCLGEGEKCADWSGPSCCDGCSCRSMPYCRCRNNSAAADNI
LYGETLSTGEFLNYGSFVFIMQEDCNLVLYDVKPIWATNTGGLSRS
CFLSMQTDGNLVVYNPSNKPIWASNTGGQNGNYVCILQKDRNVVIYG
TDRWATGVDHHHHHH

(C)

MRFPSIFTAVLFAASSALAAPVNTTTEDETAQIPAEAVIGYSDLEGDFD
VAVLPFSNSTNNGLLFINTTASIAAKEEGVSLEKREAEAAAE DTRADL
QGGEAAEKVFRPAAAGCLGEGEKCADWSGPCCDGFYCSCRSMPYCRC
RNNSAAADNILYGETLSTGEFLNYGSFVFIMQEDCNLVLYDVKPIW
ATNTGGLSRSCFLSMQTDGNLVVYNPSNKPIWASNTGGQNGNYVCIL
QKDRNVVIYGTDRWATGVDHHHHHH

Figure 3.4

Sequences of predicted products from expression constructs for Ao1bPro-P11a (A), Ao1bPro-P11a/GNA (B) and Hv1aPro-P11a/GNA (C). Red-color regions indicate sequence provided by the vector (α -factor signal sequence); Green-color regions indicate recombinant GNA; Blue-color regions indicate Ao1bPro-P11a peptide (A, B) and Hv1aPro-P11a peptide (C).

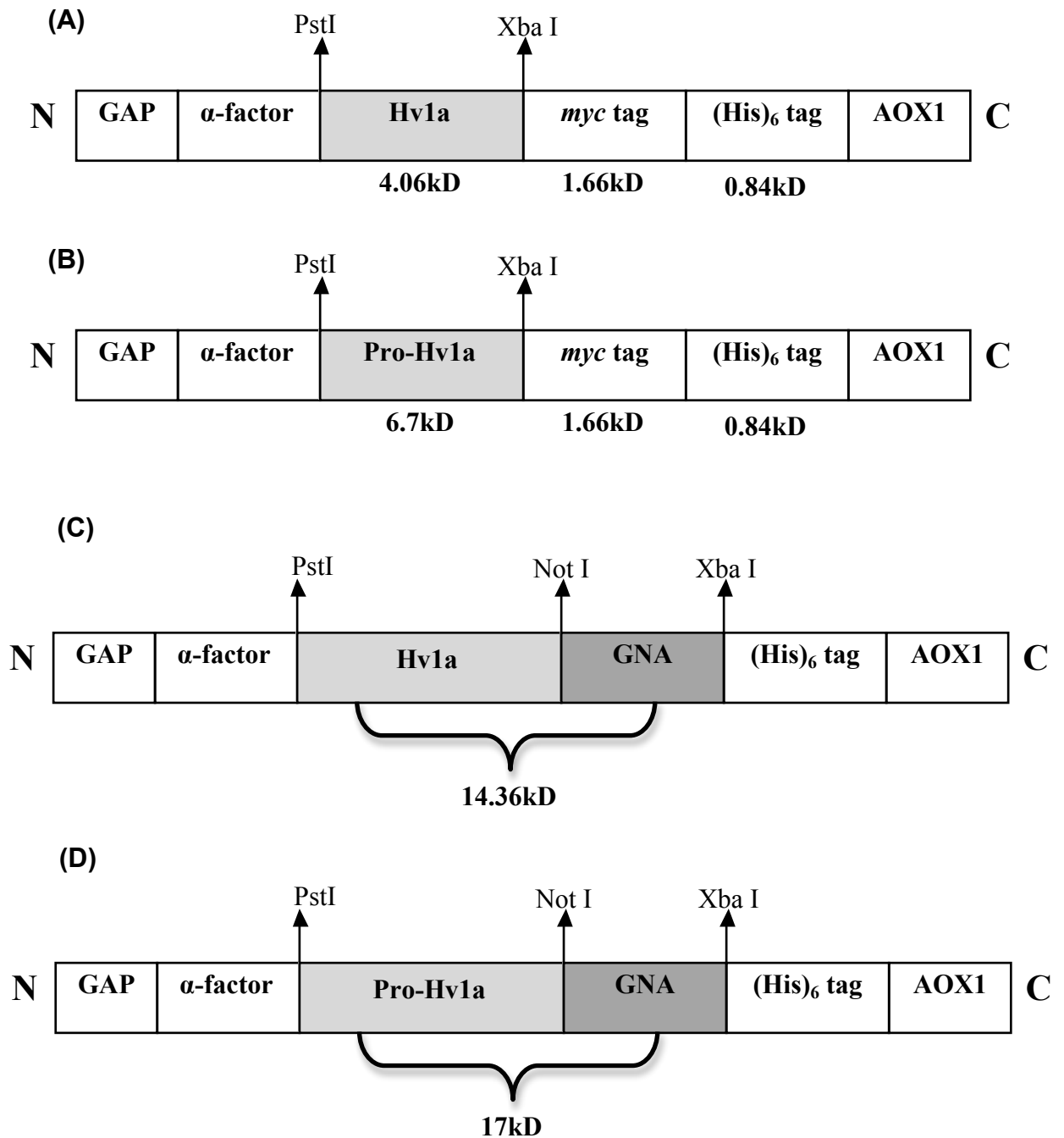

Figure 3.5

Diagrammatic representation of recombinant Hv1a (A), Pro-Hv1a (B), Hv1a/GNA (C) and Pro-Hv1a/GNA (D) constructs with restriction sites integrated into pGAPZ α B, respectively. The position of the pGAPZ α B N-terminal (GAP promoter region and α -factor signal sequence) and C-terminal (histidine tag and AOX1 transcription termination region) are shown in the figure.

(A)

MRFPSIFTAVLFAASSALAAPVNTTTEDETAQIPAEAVIGYSDLEGDFD
VAVLPFSNSTNNGLLFINTTASIAAKEEGVSLEKREAEAAASPTCIPSG
QPCPYNENCCSQSCTFKENENGNTVKRCDALEQKLISEEDLNSAVDHH
HHHH

(B)

MRFPSIFTAVLFAASSALAAPVNTTTEDETAQIPAEAVIGYSDLEGDFD
VAVLPFSNSTNNGLLFINTTASIAAKEEGVSLEKREAEAAEDTRADL
QGGEAAEKVFRRSPTCIPSGQPCPYNENCCSQSCTFKENENGNTVKRC
DALEQKLISEEDLNSAVDHHHHHH

(C)

MRFPSIFTAVLFAASSALAAPVNTTTEDETAQIPAEAVIGYSDLEGDFD
VAVLPFSNSTNNGLLFINTTASIAAKEEGVSLEKREAEAAASPTCIPSG
QPCPYNENCCSQSCTFKENENGNTVKRCDAADNILYSGETLSTGEFL
NYGSFVFIMQEDCNLVLYDVKPIWATNTGGLSRSCFLSMQTDGNLV
VYNPSNKPIWASNTGGQNGNYVCILQKDRNVVIYGTDRWATGVDHH
HHHH

(D)

MRFPSIFTAVLFAASSALAAPVNTTTEDETAQIPAEAVIGYSDLEGDFD
VAVLPFSNSTNNGLLFINTTASIAAKEEGVSLEKREAEAAEDTRADL
QGGEAAEKVFRRSPTCIPSGQPCPYNENCCSQSCTFKENENGNTVKRC
DAAADNILYSGETLSTGEFLNYGSFVFIMQEDCNLVLYDVKPIWATN
TGGLSRSCFLSMQTDGNLVVYNPSNKPIWASNTGGQNGNYVCILQKD
RNVVIYGTDRWATGVDHHHHHH

Figure 3.6

Sequences of predicted products from expression constructs for Hv1a (A), Pro-Hv1a (B), Hv1a/GNA (C) and Pro-Hv1a/GNA (D). Red-color regions indicate sequence provided by the vector (α -factor signal sequence); Green-color regions indicate recombinant GNA; Blue-color regions indicate Hv1a peptide (A, C) and Pro-Hv1a peptide (B, D).

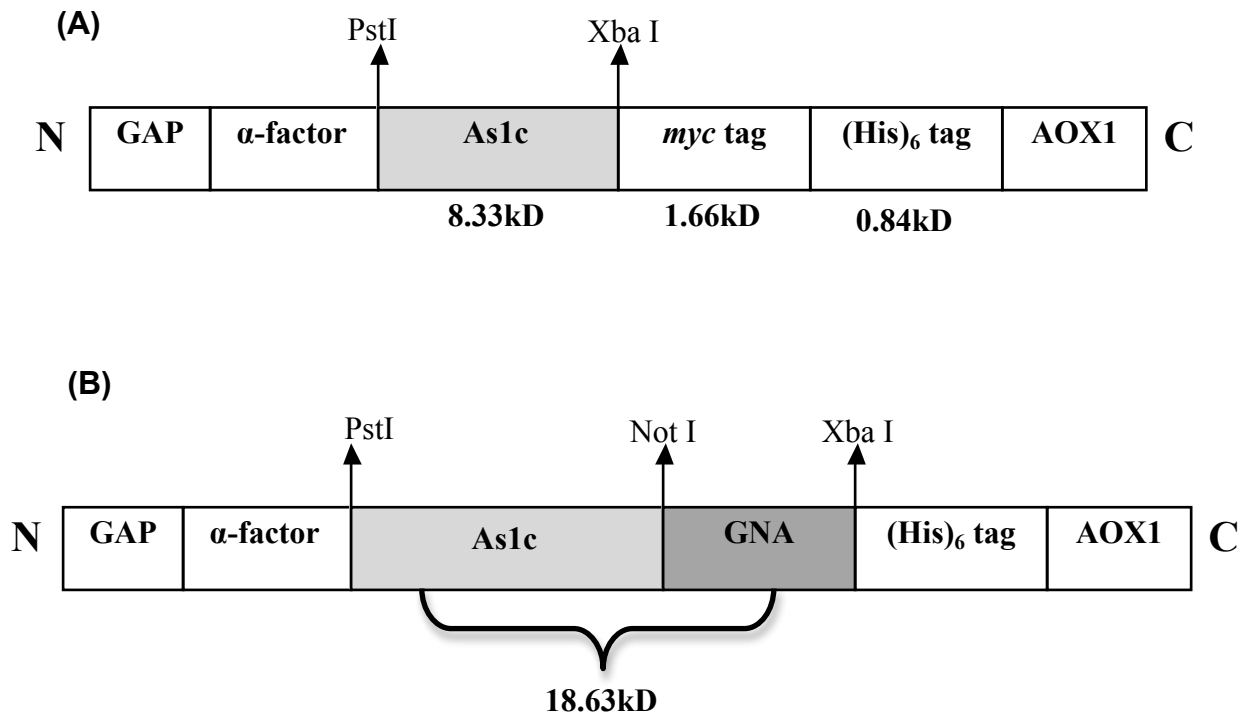

Figure 3.7

Diagrammatic representations of As1c toxin (A) and As1c/GNA fusion protein (B) constructs with restriction sites integrated into pGAPZ α B. The position of the pGAPZ α B N-terminal (GAP promoter region and α -factor signal sequence) and C-terminal (histidine tag and AOX1 transcription termination region) are shown in the figure.

(A)

MRFPSIFTAVLFAASSALAAPVNTTTEDETAQIPAEAVIGYSDLEGDFD
VAVLPFSNSTNNGLLFINTTASIAAKEEGVSLEKREAEAAAEIPQNLGS
GIPHDKIKLPNGQWCKTPGDLCSSSSECCAKHSNSVTYASFCSRQWS
GQQALFINQCRTCNESSMCALEQKLISEEDLNSAVDHHHHHH

(B)

MRFPSIFTAVLFAASSALAAPVNTTTEDETAQIPAEAVIGYSDLEGDFD
VAVLPFSNSTNNGLLFINTTASIAAKEEGVSLEKREAEAAAEIPQNLGS
GIPHDKIKLPNGQWCKTPGDLCSSSSECCAKHSNSVTYASFCSRQWS
GQQALFINQCRTCNESSMCAAADNLYSGETLSTGEFLNYGSFVFIMQ
EDCNLVLYDVKPIWATNTGGLSRSCFLSMQTDGNLVVYNPSNKPIW
ASNTGGQNGNYVCILQKDRNVVIYGTDRWATGVDHHHHHH

Figure 3.8

Sequences of predicted products from expression constructs for As1c toxin (A) and As1c/GNA fusion protein (B). Red-color regions indicate sequence provided by the vector (α -factor signal sequence); Green-color regions indicate recombinant GNA; Blue-color regions indicate As1c peptide (A, B).

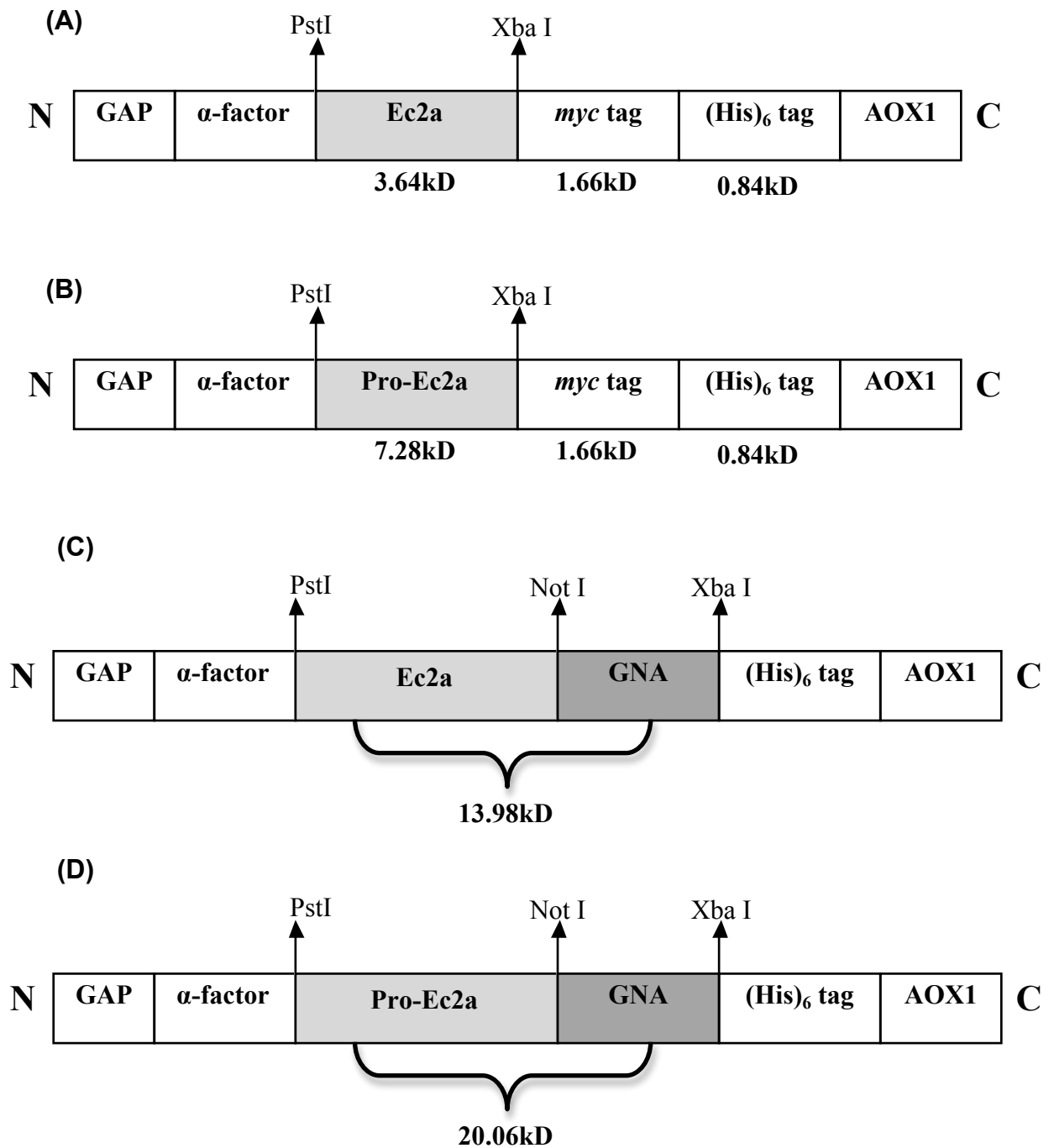

Figure 3.9

Diagrammatic representations of Ec2a toxin (A), Pro-Ec2a toxin (B), Ec2a/GNA (C) and Pro-Ec2a/GNA fusion proteins (D) constructs with restriction sites integrated into pGAPZ α B. The position of the pGAPZ α B N-terminal (GAP promoter region and α -factor signal sequence) and C-terminal (histidine tag and AOX1 transcription termination region) are shown in the figure.

(A)
MRFPSIFTAVLFAASSALAAPVNTTTEDETAQIPAEAVIGYSDLEGDFDVA
VLPFSNSTNGLLFINTTASIAAKEEGVSLEKREAEAAAYCQKFLWTCDT
ERKCCEDMVCELWCKLEKALEQKLISEEDLNSAVDHHHHHH

(B)
MRFPSIFTAVLFAASSALAAPVNTTTEDETAQIPAEAVIGYSDLEGDFDVA
VLPFSNSTNGLLFINTTASIAAKEEGVSLEKREAEAAALEEQDHLNLRND
LLTVMFAENSELTPETEERYCQKFLWTCDTERKCCEDMVCELWCKLEKA
LEQKLISEEDLNSAVDHHHHHH

(C)
MRFPSIFTAVLFAASSALAAPVNTTTEDETAQIPAEAVIGYSDLEGDFDVA
VLPFSNSTNGLLFINTTASIAAKEEGVSLEKREAEAAAYCQKFLWTCDT
ERKCCEDMVCELWCKLEKAAADNILYSGETLSTGEFLNYGSFVFIMQEDC
NLVLYDVKPIWATNTGGLSRSCFLSMQTDGNL VVYNPSNKPIWASNTG
GQNGNYVCILQKDRNVVIYGTDRWATGVDHHHHHH

(D)
MRFPSIFTAVLFAASSALAAPVNTTTEDETAQIPAEAVIGYSDLEGDFDVA
VLPFSNSTNGLLFINTTASIAAKEEGVSLEKREAEAAALEEQDHLNLRND
LLTVMFAENSELTPETEERYCQKFLWTCDTERKCCEDMVCELWCKLEKA
AADNILYSGETLSTGEFLNYGSFVFIMQEDCNLVLYDVKPIWATNTGGLS
RSCFLSMQTDGNL VVYNPSNKPIWASNTGGQNGNYVCILQKDRNVVIYGT
DRWATGVDHHHHHH

Figure 3.10

Sequences of predicted products from expression constructs for Ec2a (A), Pro-Ec2a (B), Ec2a/GNA (C) and Pro-Ec2a/GNA (D). Red-color regions indicate sequence provided by the vector (α -factor signal sequence); Green-color regions indicate recombinant GNA; Blue-color regions indicate Ec2a peptide (A, C) and Pro-Ec2a peptide (B, D).

3.2 Expression and purification of recombinant toxins and fusion proteins

Verified clones of expression constructs were transformed into the protease-deficient *P. pastoris* strain SMD1168H, using antibiotic (zeocin) selection for transformants. Approx. 40-50 resistant colonies were obtained for each expression construct. Culture supernatant from selected clones grown in shake-flask cultures was analysed for production of recombinant proteins by Western blotting, to allow selection of clones producing the highest levels of these fusion proteins. Screening of large numbers of transformed yeast clones was not necessary, since most clones were expressing recombinant proteins, as judged by the presence of immunoreactive bands of the expected size on Western blots of culture supernatants. For example, the western blot results showed clear bands of the transformed yeast clones including P11a/GNA or Pro-Hv1a/GNA fusion protein (Fig. 3.11). Unfortunately, the As1c/GNA fusion protein, Pro-Ec2a and Hv1aPro-P11a recombinant toxins could not be secreted to the supernatant from the yeast cells. Therefore, no As1c/GNA fusion protein, Pro-Ec2a or Hv1aPro-P11a recombinant toxins were obtained.

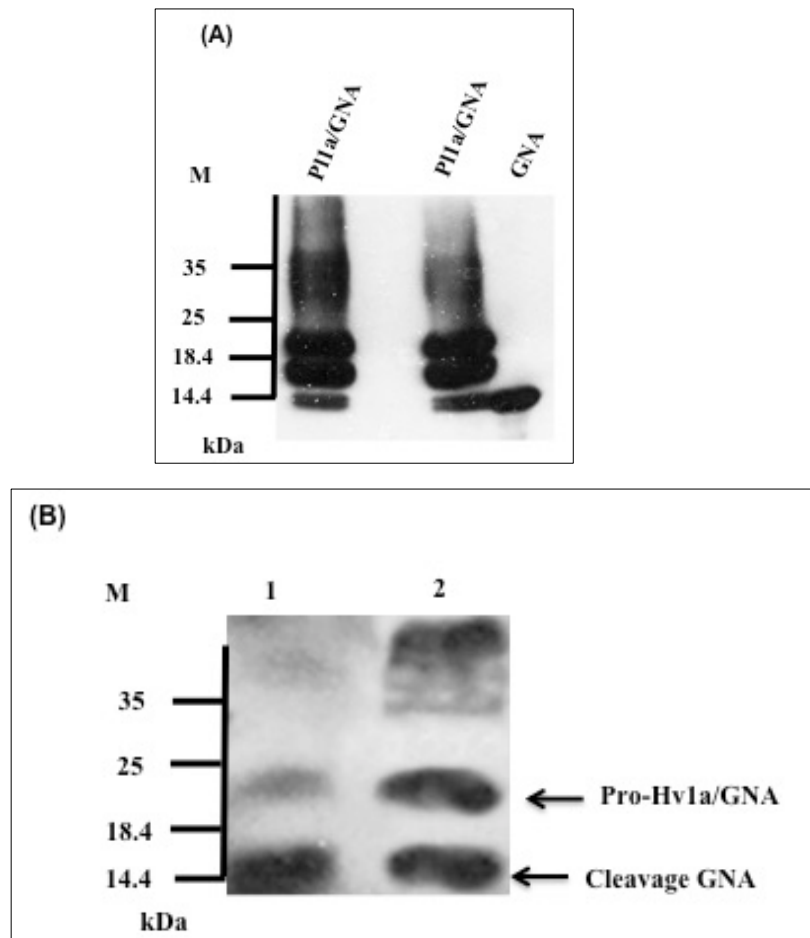

Figure 3.11

Western blotting analysis of clones of recombinant P11a/GNA and Pro-Hv1a/GNA fusion proteins from shake-flask yeast cultures using anti-GNA tag. (A) P11a/GNA fusion protein. (B) Pro-Hv1a/GNA fusion protein (band indicated by open arrowhead). Lanes 1 and 2 are loaded 50ng and 100ng Pro-Hv1a/GNA fusion protein, respectively.

For each construct, the best-expressing clone of those screened in small-scale cultures was selected for large-scale protein production by bench top fermentation. Fermentation of selected clones was carried out in a 5L bioreactor under controlled environmental conditions. The use of the pGAP alpha factor secretory signal that directs the secretion of expressed proteins out of the cells and into the growth media enabled subsequent purification of recombinant proteins from fermented culture supernatants. Supernatants were obtained by centrifugation, clarified by filtration and subsequently purified by nickel affinity chromatography. Eluted peaks containing target proteins were desalted by dialysis, and lyophilised. Yields of recombinant proteins were comparable to other fusion proteins prior to optimization. P11a, Hv1a and Pro-Hv1a were produced at approx. 26 mg/L, 80 mg/L and 40 mg/L, respectively, as estimated by BCA quantification. P11a/GNA was produced at approx. 21 mg/L; Hv1a/GNA at approx. 50 mg/L (Fitches et al., 2012); Pro-Hv1a/GNA at approx. 21 mg/L; Ao1bPro-P11a at approx. 32 mg/L; Ao1bPro-P11a/GNA at approx. 32 mg/L; Hv1aPro-P11a at approx. 13 mg/L; As1c at approx. 19.75 mg/L; Ec2a toxin at approx. 11 mg/L; Ec2a/GNA at approx. 7 mg/L and Pro-Ec2a/GNA at approx. 5 mg/L, respectively, estimated by semi-quantitative SDS-PAGE.

Discussion

The δ -amaurobitoxin P11a was selected as a possible component for bio-pesticidal fusion proteins for reasons described earlier (insecticidal activity and insect-specificity), but also because it is effective against a different target than previous insecticidal neurotoxins used in lectin-based fusion proteins; SFI1, from the spider *S. florentina* (Fitches et al., 2004) has an unknown target, ButaIT from the scorpion *M. tamulus* (Trung et al., 2006) is assumed to target chloride channels, and Hv1a, from the spider *H. versuta* (Fitches et al., 2012) targets calcium channels. As a toxin, which targets the insect sodium channel (Corzo et al., 2005), P11a therefore represents another type of insecticidal component, which has the same target with most conventional pesticides (Ferrat et al., 2005). The insect sodium channel is a major target for conventional pesticides, such as pyrethroids, and inactivation leads to rapid paralysis and death; exploitation of this target in the insect is thus based on established practice. Although most spider toxins just slow NaCh inactivation in a fashion similar to that of receptor site 3 modifiers, δ -amaurobitoxins are similar to

scorpion β -toxins in binding with high affinity to the topologically distinct receptor site 4, which involves the extracellular loops of S1-S2, S3-S4 of domain II in insect and mammalian NaChs, though they have developed from different ancestors (Cestèle et al., 1998; Cestèle and Catterall, 2000). It affects the functional properties of the sodium channel α subunit by shifting the voltage dependence of activation, resulting in paralysis; the effect is similar to that produced by pyrethroids (Zlotkin, 1999). The δ -amaurobitoxins like P11a recognize insect voltage-gated sodium channels by multiple sequence features, including a β -sheet secondary structure, loops I, IV of the toxin and the specific dipolar moment orientation (Ferrat et al., 2005). The roles of different amino acid residues in determining binding and toxicity have been investigated by alanine scanning mutagenesis (Fig. 3.12) (Corzo et al., 2005). These results can be exploited to manipulate the toxin component of a fusion protein if necessary to modify activity or specificity. Data for the insecticidal activity of P11a (Arachnoserver) suggests that it shows a higher LD₅₀ on a mole/g basis than that reported for Hv1a, the toxin component of the atracotoxin/GNA fusion protein described by Fitches et al. (2012).

(A)

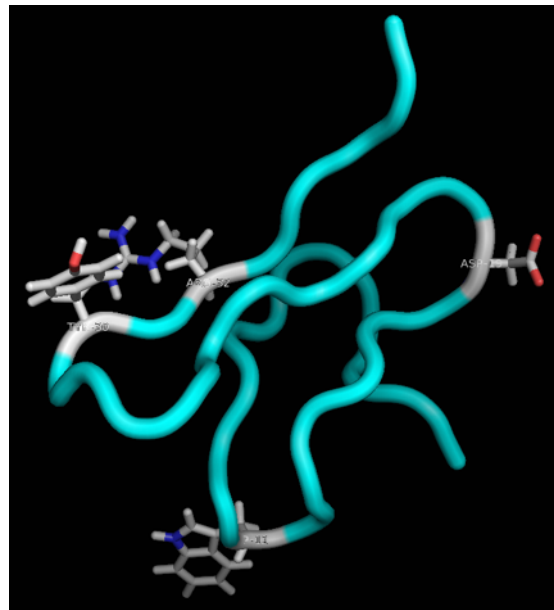

(B)

GCLGEGEKCADKSGPSCCGYCSQRSMPCRCRNNNS

Figure 3.12

The roles of different amino acid residues in determining binding and toxicity of P11a toxin. (A) Cartoon backbone model of P11a showing side chains of residues, which cause loss of insecticidal activity when mutated as sticks. Asp-19, the residue thought to be causal in insecticidal activity is mid-right. Residues, which cause loss of binding when mutated are clustered along the peptide backbone running across the centre of the molecule from Asp-19 (right) to Tyr-30 (left) (Corzo et al., 2005). (B) Highlighted sequences of P11a toxin showing residues in determining binding and toxicity. Yellow highlights show residues, which affect binding, pink residues affect binding and insecticidal activity, green highlight shows residue, which affects insecticidal activity only. Mutation of Asn-35 to remove an N-glycosylation site (see Chapter 4 in thesis) is not predicted to affect activity.

The ω -hexatoxin-Hv1a (Hv1a) gene provides a precursor of Hv1a venom peptide toxin, which is composed of a native N-terminal signal peptide, a Pro-region rich in acidic residues and the mature toxin sequence. The mature Hv1a venom peptide is released with a conserved cysteine framework during post-translational modifications (Sollod et al., 2005). Hv1a, as a cysteine-knot peptide that targets insect calcium ion channels that are critical for neuronal communication and neurotransmitter release, was selected as a component for bio-pesticidal fusion proteins due to its high insecticidal activity and insect-specificity (Chapter 1) (Fletcher et al., 1997; Tedford et al., 2004a; Tedford et al., 2004b; Catterall et al., 2007; Fitches et al., 2012).

The toxins of κ -theraphotoxin-Ec2a, which is able to inhibit insect delayed-rectifier K⁽⁺⁾ currents, belongs to one of a family of three new "short-loop" inhibitory cysteine knot insecticidal toxins containing κ -TRTX-Ec2a, κ -TRTX-Ec2b, and κ -TRTX-Ec2c isolated from the venom of the African tarantula *Eucratoscelus constrictus* (Windley et al., 2011). Ec2a shows different C terminal, which confers Ec2a the characteristic of insect-selective function, in comparison to other theraphotoxins. This difference results in the phyla selectivity of Ec2a involved in targeting BK_(Ca) channels of insect with an IC₅₀ of 3.7nM (Windley et al., 2011). The toxin U1-cyrtautoxin-As1c (As1c), which contains four disulfide bonds with an LD₅₀ of 0.02 mg/kg by subcutaneous injection, is also a strictly insect-selective neurotoxin that comprises an inhibitory cysteine knot fold (Skinner et al., 1992; Gunning et al., 2008; Windley et al., 2011).

In several research cases, native N-terminal Pro-regions have been shown to play an important role in the protein folding, stabilising the tertiary structure of the mature protein and transporting of cysteine knot proteins (Eder and Ferscht, 1995; Rattenholl et al., 2001; Lu, 2003; Sollod et al., 2005; Hoffmann *et al.*, 2008; Geng et al. 2012; McCormick et al. 2012). Here, the native N-terminal Pro-region of Hv1a represents a reinforced type of insecticidal component of Hv1a. Consequently, two expression constructs including Pro-Hv1a and Pro-Hv1a/GNA were made. Bioassay data showed that Pro-region significantly enhanced the toxicities of both Pro-Hv1a and Pro-Hv1a/GNA (Chapter 5). Inspired by the surprising results of Pro-Hv1a toxin and Pro-Hv1a/GNA fusion protein, another four constructs: Ao1bPro-P11a,

Ao1bPro-P11a/GNA and Hv1aPro-P11a/GNA; Pro-Ec2a/GNA were also made, all of which were synthetic N-terminal Pro-regions for P11a or Ec2a toxin, as the sequences of these native Pro-regions are unclear.

The yeast *P. pastoris* was selected as expression host for production of recombinant fusion proteins on the basis of previous work showing that small proteins containing multiple disulphide bonds can be produced in active form in this organism (Cereghino and Cregg, 2000). Efficient secretion of expressed proteins into the culture medium, directed by the yeast α -factor pre-Pro-sequence incorporated into the expression vector pGAPZ α , is an additional advantage in that purification of the recombinant protein is simplified by having relatively few contaminating *Pichia* proteins present in the culture medium, and not having to lyse cells to obtain the product (Chapter 1).

Summary

The toxins in this chapter all have potential to be used as bio-insecticides in crop protection when linked to the carrier GNA, as all of them are insecticidal toxins that cause flaccid paralysis and mortality of pests by injection. None of the toxins show toxicity to vertebrates. Moreover, some of them could be produced at high levels in the yeast *P. pastoris*, which will reduce the cost in the commercial market. The next three chapters evaluate the efficacy of P11a, Pro-Hv1a and their fusion proteins in bioassays against insects of different orders.

CHAPTER 4 RECOMBINANT SPIDER TOXIN PL1A, SPECIFIC FOR THE INSECT VOLTAGE-GATED SODIUM ION CHANNELS, SHOWS ORAL TOXICITY TOWARDS INSECTS OF DIFFERENT ORDERS WHEN FUSED TO GNA

Introduction

δ -Amaurobitoxins, or δ -palutoxins, from the spider *Pireneitega luctuosus* (Araneae: Amaurobiidae; previously referred to as *Paracoelotes luctuosus*) belong to a family of four similar 36-37 residue peptides, designated P11a-d (Corzo et al., 2000). They contain 8 cysteine residues, which are disulphide-linked to form a cysteine knot motif. The δ -amaurobitoxins are effective insecticides, with the LD₅₀ values of 0.95-4.48 μ g/100mg when injected into Lepidopteran larvae (oriental leafworm moth; *Spodoptera litura*). They show insect-specific toxicity, with no effects observed for P11a, P11c and P11d after intravenous injection in mice (Corzo et al., 2000). The amaurobitoxins specifically target insect sodium channels, and their solution structure has elucidated the nature of the interaction (Corzo et al., 2005; Ferrat et al., 2005). The toxin P11a was selected as the subject of this study as it combines the highest insecticidal activity with no observed toxicity towards higher animals, and thus would be suitable as a bio-pesticide.

The present chapter reports the characterization and biological activities of recombinant toxins P11a and Ao1bPro-P11a; the fusion proteins P11a/GNA, Ao1bPro-P11a/GNA and Hv1aPro-P11a/GNA. The results in this chapter show that fusion to GNA enhances the insecticidal activity of P11a. The fusion protein was not only more toxic than recombinant P11a when injected into cabbage moth (*M. brassicae*) larvae, but it also had effective oral toxicity when the toxin alone did not. The fusion protein was also orally toxic to insects of different orders, pea aphids (*A. pisum*; Hemiptera) and housefly (*M. domestica*; Diptera). Moreover, P11a/GNA, inclusion of Ao1b Pro-region sequence in the expression construct (Ao1bPro-P11a/GNA), and inclusion of Hv1a Pro-region sequence in the expression construct

(Hv1aPro-P11a/GNA) both showed enhanced toxicities to insect pests as compared to P11a/GNA without addition of synthetic Pro-region sequences. The addition of homologous or heterologous Pro-region sequences to P11a/GNA expression constructs resulted in enhanced biological activity, offering potential to be used as bio-pesticides for crop protection in the future.

4.1 Characterization of recombinant P11a and P11a/GNA

Purified recombinant proteins were analysed by SDS-PAGE and western blot. The recombinant toxin P11a (Fig. 4.1 A) ran as a closely spaced double band at an indicated mol. wt. of approx. 18kDa on normal SDS-PAGE gels; both bands were immunoreactive with anti-(His)₆ antibodies by Western blotting (not presented). The predicted mol. wt. of recombinant P11a, including the tag sequences is 7.07kDa. The double band and incorrect mol. wt. of toxin was reproducible with different gels, samples, and use of reducing agents prior to electrophoresis, but was considered to be an artefact of the gel system, possibly as a result of poor binding of SDS to the polypeptide. This is because P11a belongs to the cysteine knot peptide family, which contains at least 3 disulphide bonds. It is difficult to break the disulphide bonds on SDS page. Moreover, the toxin is easy to be glycosylated in the yeast, which has already been proven by MALDI-TOF mass spectrometry (data not shown). When the same samples were treated with 6M urea prior to electrophoresis, P11a gave a single band at an indicated mol. wt. of 14kDa (Fig. 4.1 B); the shift in mobility is indicative of gel artefacts, and the single band indicates homogeneity of the product. Further analysis on urea-containing gels gave single bands for P11a, with indicated mol. wts. of approx. 11kDa without blocking cysteine residues, and approx. 9kDa after treatment with iodoacetamide to block cysteine residues (data not presented); these results are diagnostic of incorrect mol. wts. under "normal" conditions due to residual secondary structure and interactions between cysteine residues prior to or during electrophoresis.

The P11a/GNA fusion protein (Fig. 4.1 C) contained a closely spaced double band of an indicated size of 18kDa, similar to the expected molecular weight for the fusion protein (17.3kDa); pretreatment of samples with 6M urea caused a slight shift in molecular weight to a lower value, and replacement of the double band by a single

band, once again suggesting the double band was an artefact (data not presented). The N-terminal sequence of the single band was determined as NH₂-Glu-Ala-Ala-Ala-Gly, as expected for the fusion protein after removal of the yeast α -factor prePro-region during translation and secretion from *Pichia*. The fusion protein gave two further bands on gel when analysed by SDS-PAGE. It contained a small amount of a band at an indicated molecular weight similar to recombinant GNA (12.7kDa), which was immunoreactive to anti-GNA antibodies, suggesting a small amount of cleavage of the fusion protein into its components was occurring during production and purification. The ratio of intact P11a/GNA fusion protein to cleaved GNA was estimated as approx. 30:1 as judged by Coomassie blue staining on SDS-PAGE gels. The P11a/GNA fusion protein also contained a prominent band at an indicated mol. wt. of approx. 21kDa, roughly equal in intensity to the band assumed to be P11a/GNA fusion protein. This was again immunoreactive with anti-GNA antibodies, and had an identical N-terminal sequence to the 18kDa band. Treatment with the deglycosylating enzyme PNGase F, which cleaves carbohydrate side chains attached to Asn residues through N-glycosidic bonds, removed this band, while the intensity of the "correct" band for the P11a/GNA fusion protein increased as a result of the treatment (Fig. 4.1 D). This result suggests that the extra band is due to "core" glycosylation of the fusion protein by *P. pastoris* during synthesis and secretion. Moreover, protein N-terminal sequencing result also shows the 21kDa band has the same amino acids with the 18kDa band (Fig. 4.2). GNA contains no potential N-glycosylation sites, but the P11a toxin sequence contains a potential N-glycosylation site (N-X-S/T) at Asn-35. Quantitation of the P11a/GNA fusion protein was based on the combined intensity of both the bands representing the glycosylated and non-glycosylated forms. Treatment with PNGase F also removed a "smear" of material of higher molecular weight on SDS-PAGE in P11a/GNA, which was assumed to represent hyper-glycosylated fusion protein.

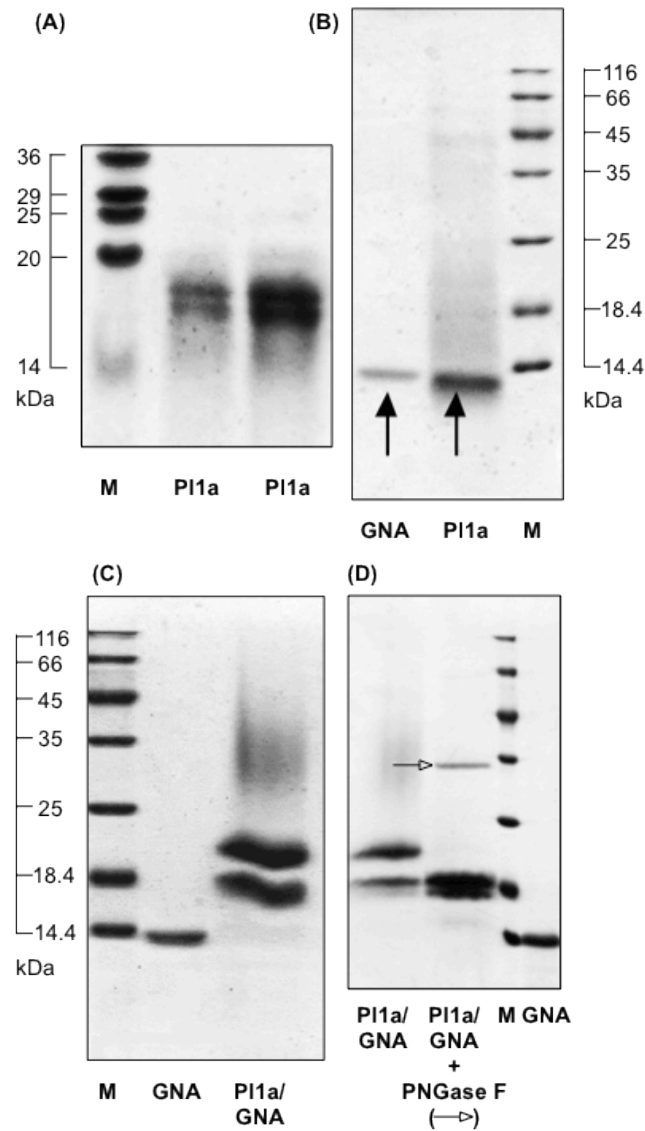

Figure 4.1

Characterisation of purified recombinant proteins by SDS-PAGE followed by Coomassie blue staining. (A) PI1a toxin separated on "normal" SDS-PAGE; M indicates marker, loadings of PI1a are 5 and 10 μ g. (B) PI1a toxin (5 μ g) separated on SDS-PAGE after denaturation by 6M urea. (C) PI1a/GNA fusion protein (10 μ g). (D) Deglycosylation of PI1a/GNA fusion protein using PNGase F (band indicated by open arrowhead).

Chapter 4 Recombinant spider toxin P11a, specific for the insect voltage-gated sodium ion channels, shows oral toxicity towards insects of different orders when fused to GNA

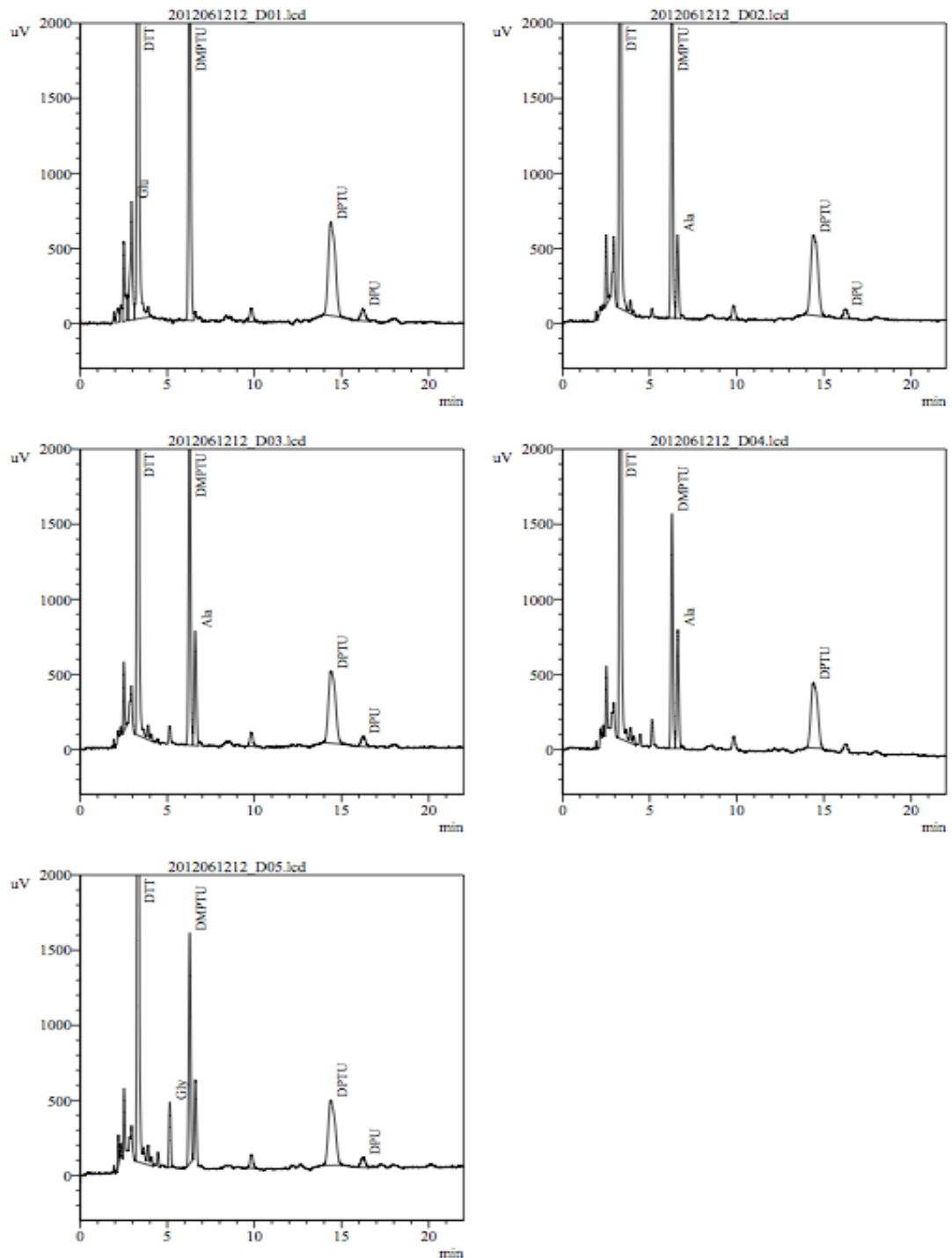

Figure 4.2
P11a/GNA fusion protein N-terminal sequencing results. Five amino acids were sequenced. Panel 1: Glu; panel 2: Ala; panel 3: Ala; panel 4: Ala; panel 5: Gly.

4.2 Characterization of recombinant Ao1bPro-P11a, Ao1bPro-P11a/GNA and Hv1aPro-P11a/GNA

P11a produced by the modified construct incorporating the Pro-region (Ao1bPro-P11a) ran as a closely spaced double band at approx. 9kDa under "normal" SDS-PAGE conditions, with some evidence of a diffuse band at higher mol. wt. (Fig. 4.3 A, B). The predicted molecular mass of the peptide including the additional Pro-region is 8.6 kDa. N-terminal sequencing confirmed that the Pro-region was present in the protein product and that cleavage had occurred between alanine and the primary residue of the Ao1b Pro-region isoleucine giving a predicted molecular mass of 8.46 kDa (Fig. 4.4).

Both of the P11a/GNA fusion proteins derived from constructs containing additional Pro-region sequences (i.e. Ao1bPro-P11a/GNA and Hv1aPro-P11a/GNA) separated on SDS-PAGE gels as two major staining bands of approx. 17 and 21 kDa (Fig. 4.5 A, B). The smaller 17 kDa protein corresponds in mass to that predicted for Ao1bPro-P11a/GNA and Hv1aPro-P11a/GNA (16.94 kDa) following removal of the Pro-region, suggesting that in both cases the Pro-region is removed during processing by yeast cells, which has been proved by N-terminal protein sequencing (Fig. 4.6 and Fig. 4.7). The larger 21kDa protein band is most likely to represent glycosylated protein, as was observed for P11a/GNA. Ao1bPro-P11a/GNA and Hv1aPro-P11a/GNA both expressed as 100 % intact fusion protein with no evidence by SDS-PAGE and western blotting for cleavage between the toxin and GNA sequences. Quantifications of the Hv1aPro-P11a/GNA and Ao1bPro-P11a/GNA fusion proteins were based on comparative band intensity with GNA standards of known concentration as shown in Fig. 4.8 A and B.

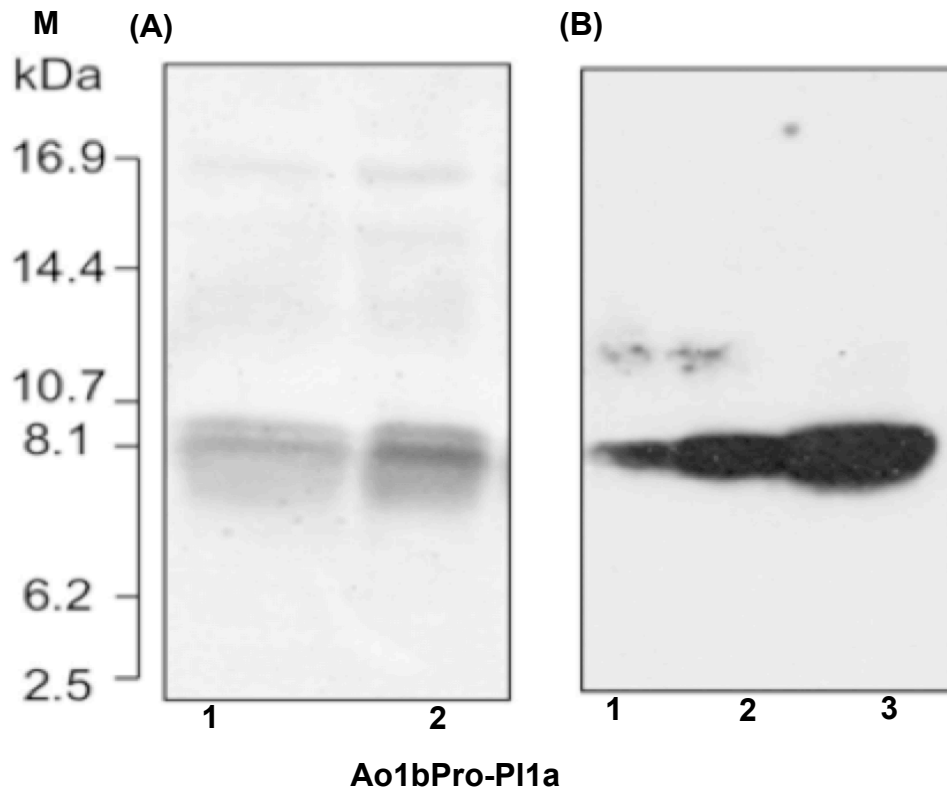

Figure 4.3

Characterisation of purified recombinant Ao1bPro-P11a toxin. (A) Recombinant Ao1bPro-P11a toxin derived from a construct containing the Pro-region designated Ao1b on SDS-PAGE. Lanes 1 and 2 are loaded 1.25 μ g and 2.5 μ g Ao1bPro-P11a toxin, respectively. (B) Western blotting of purified Ao1bPro-P11a using anti-His antibodies. Lanes 1, 2 and 3 are loaded 25, 50 and 100 ng, respectively.

Chapter 4 Recombinant spider toxin P11a, specific for the insect voltage-gated sodium ion channels, shows oral toxicity towards insects of different orders when fused to GNA

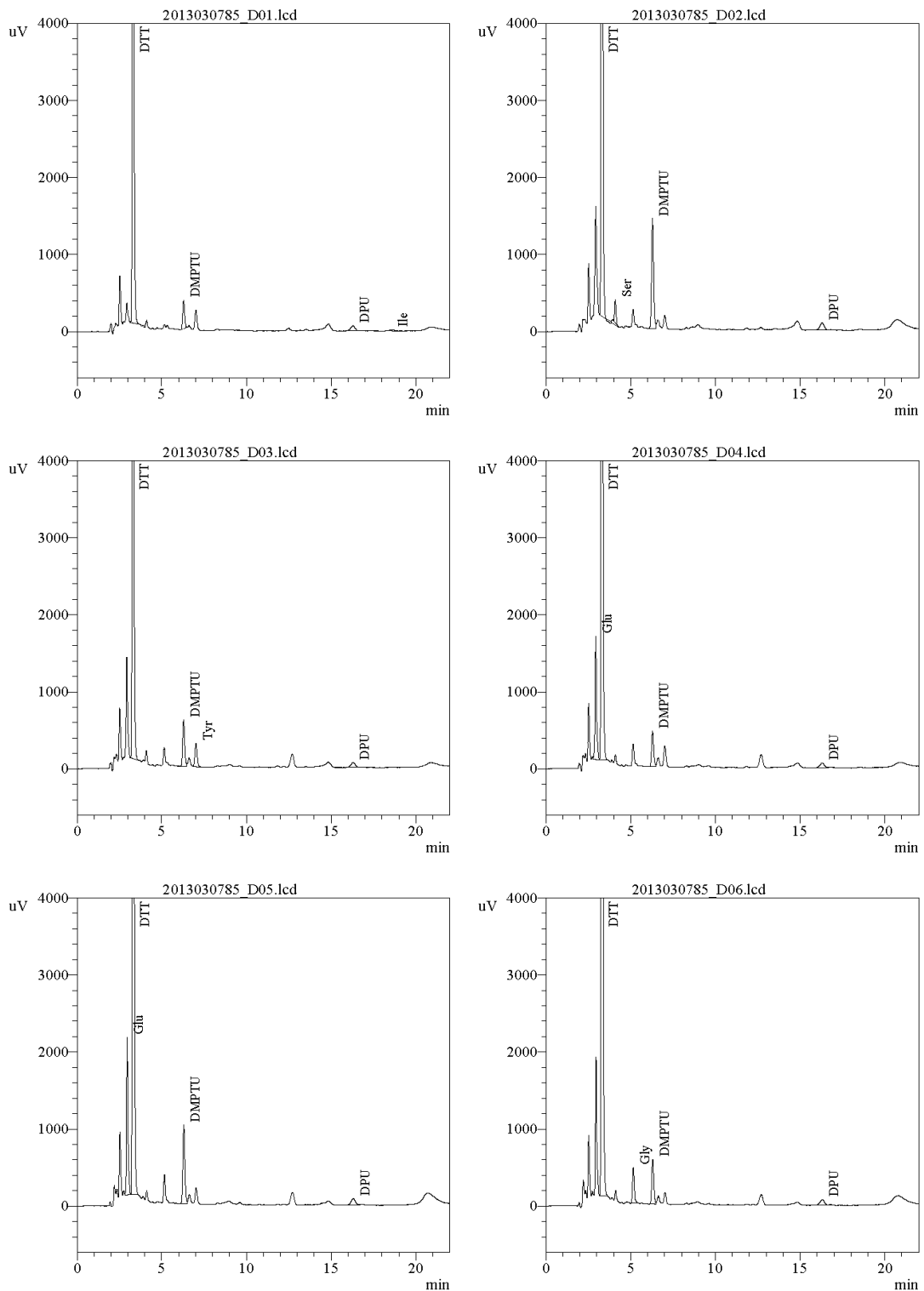

Figure 4.4

AolbPro-P11a Protein N-terminal sequencing results. Six amino acids were sequenced. Panel 1: Ile; panel 2: Ser; panel 3: Tyr; panel 4: Glu; panel 5: Glu; panel 6: Gly.

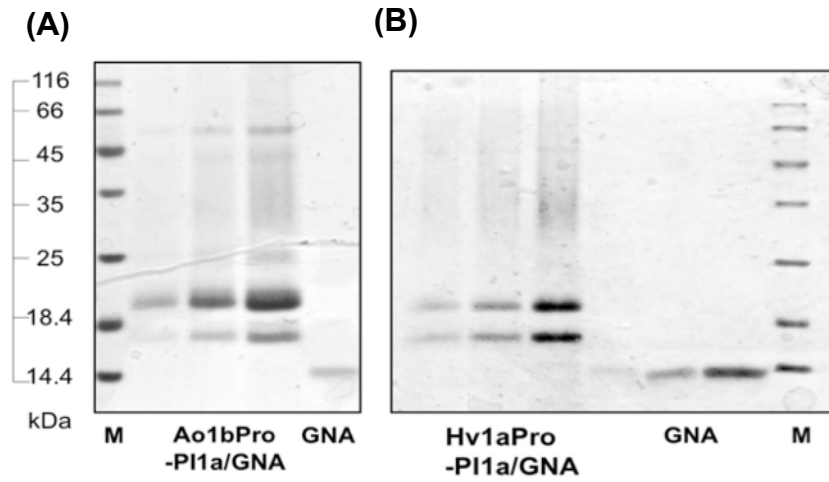

Figure 4.5

Characterization of purified recombinant Ao1bPro-P11a/GNA and Hv1aPro-P11a/GNA fusion proteins by SDS-PAGE. (A) Ao1bPro-P11a/GNA 1, 2, 4μg, GNA standard 1 μg. **(B)** Hv1aPro-P11a/GNA 1, 2, 4μg, GNA standards 1, 2, 4 μg.

Chapter 4 Recombinant spider toxin P11a, specific for the insect voltage-gated sodium ion channels, shows oral toxicity towards insects of different orders when fused to GNA

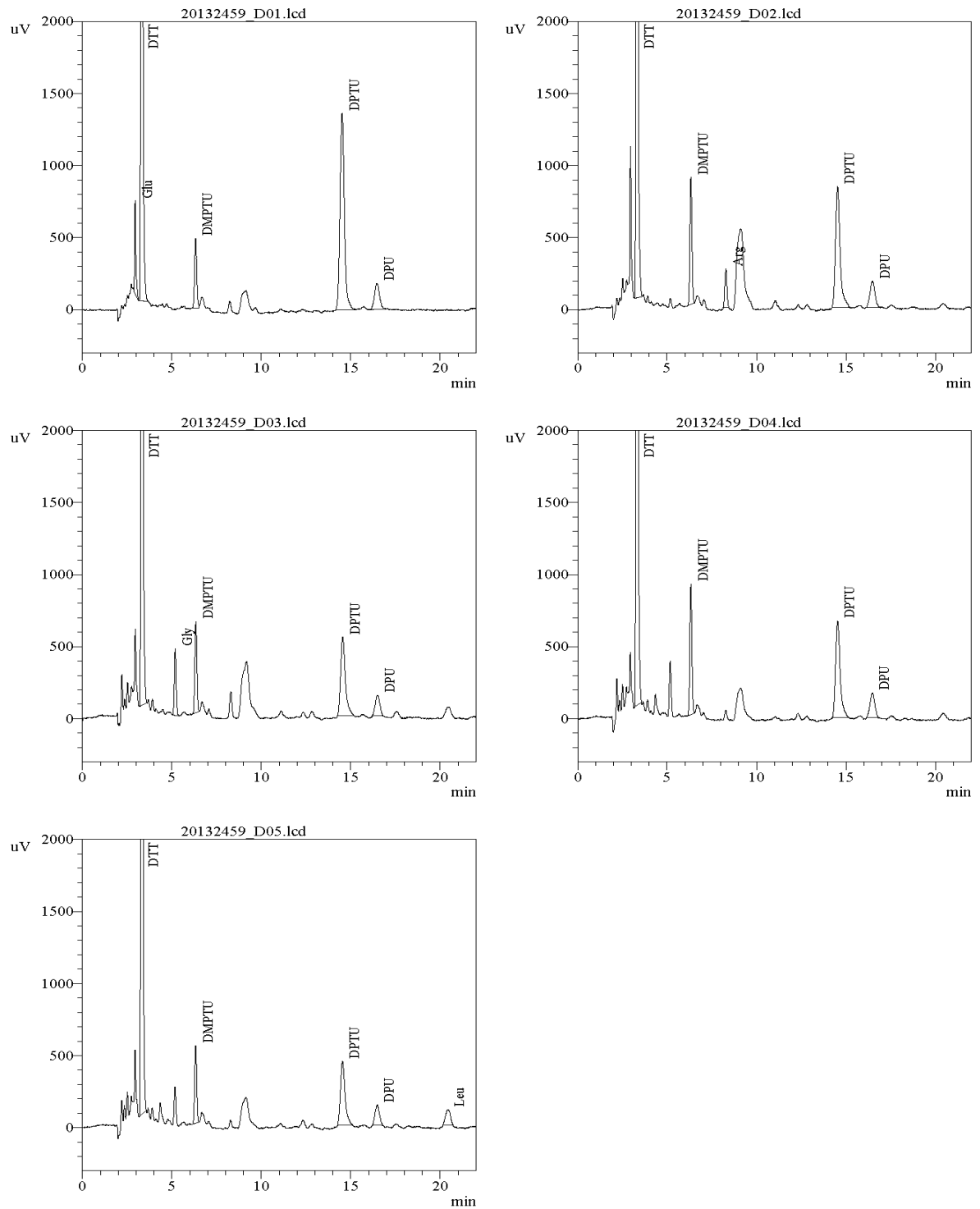

Figure 4.6

A01bPro-P11a/GNA fusion protein N-terminal sequencing results. Five amino acids are sequenced. Panel 1: Glu; panel 2: Arg; panel 3: Gly; panel 4: Cys; panel 5: Leu.

Chapter 4 Recombinant spider toxin P11a, specific for the insect voltage-gated sodium ion channels, shows oral toxicity towards insects of different orders when fused to GNA

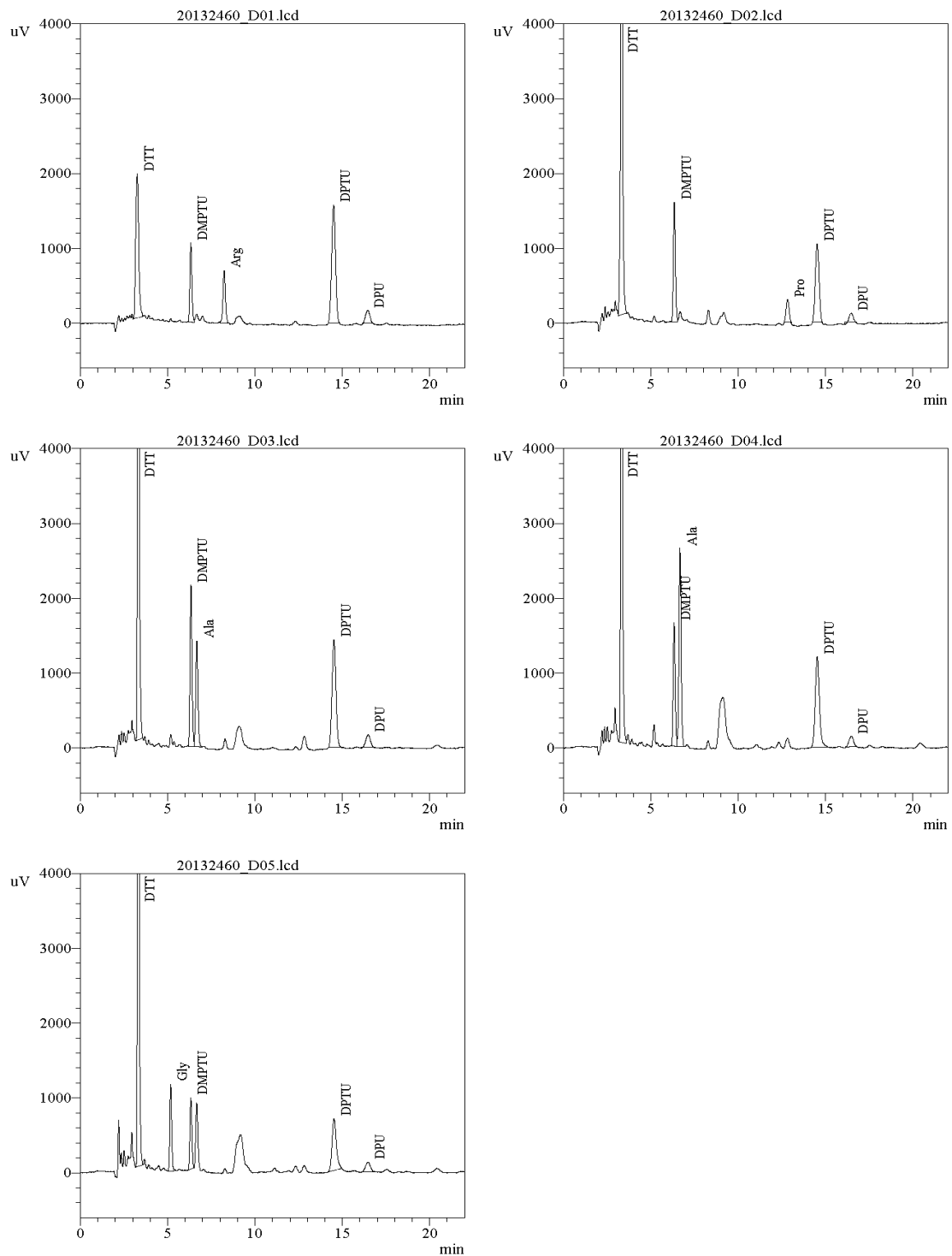
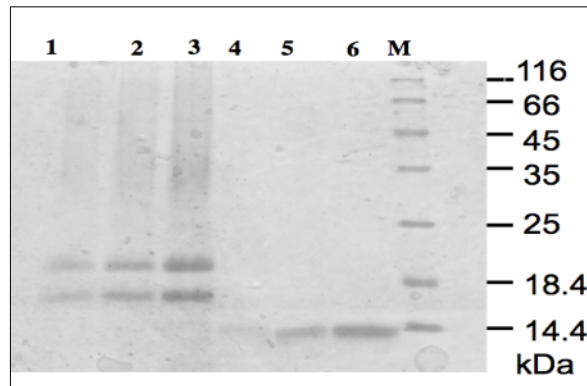

Figure 4.7

Hv1aPro-P11a/GNA fusion protein N-terminal sequencing results. Five amino acids were sequenced. Panel 1: Arg; panel 2: Pro; panel 3: Ala; panel 4: Ala; panel 5: Gly.

(A)



(B)

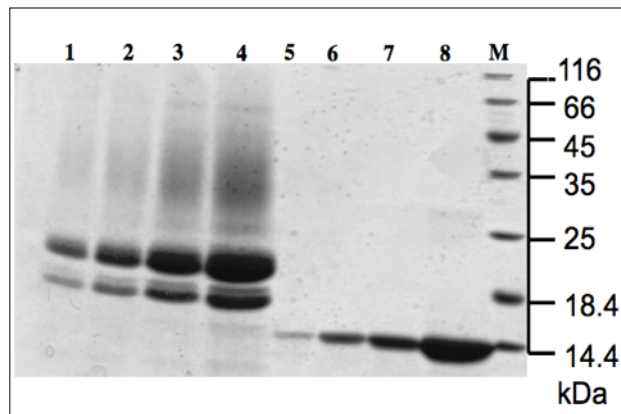

Figure 4.8

Quantifications of purified recombinant Hv1aPro-P11a/GNA (A) and Ao1bPro-P11a/GNA (B) fusion proteins. (A) Lanes 1-3 are loaded 12.5, 25 and 50 μg powder containing Hv1aPro-P11a/GNA, respectively; Lanes 4-6 are GNA standards of 1 μg , 2 μg and 4 μg . **(B)** Lanes 1-4 are loaded 12.5, 25, 50 and 100 μg powder containing Ao1bPro-P11a/GNA, respectively; Lanes 5-8 are GNA standards of 1 μg , 2 μg , 4 μg and 8 μg .

4.3 Bioassays of recombinant toxins P11a and Ao1bPro-P11a; P11a/GNA, Ao1bPro-P11a/GNA and Hv1aPro-P11a/GNA fusion proteins to cabbage moth larvae

4.3.1 Toxicities of recombinant P11a and P11a/GNA fusion protein to cabbage moth larvae after injection into the haemolymph

Newly eclosed 5th instar larvae (approx. 45-55mg in weight; average weight 50mg) of *M. brassicae* were injected with recombinant P11a and P11a/GNA fusion proteins to assay biological activity *in vivo*. Larvae injected with P11a toxin all displayed flaccid paralysis within 1-2h (little mobility and almost a complete absence of feeding). Most mortality was observed within the first 24h of the assay (Fig. 4.9 A). After a period of paralysis, some insects showed progressive recovery, and were able to recommence feeding. The effects of P11a were dose dependent, with mortality after 24h ranging from 75% at 20µg toxin / insect to 20% at 1.25µg toxin / insect. Even at high doses of toxin, complete mortality after 72h was not observed. From these assays, the LD₅₀ (48h) for the recombinant P11a was 4.1µg / insect, or 8.2µg / 100 mg insect, based on an average larval weight of 50mg.

The P11a/GNA fusion protein also caused paralysis and mortality when injected into *M. brassicae* larvae, but was significantly more effective than toxin alone ($p < 0.0001$, ANOVA). When insects were injected with 1.25-10µg fusion protein / insect (equivalent to 0.50-4.0µg P11a / insect, since the molecular weight of recombinant P11a is approx. 0.41 of that of the P11a/GNA fusion protein), significant mortality was observed at all doses, and complete mortality at 24h was observed at the highest dose (Fig. 4.9 B, C). As observed for P11a, most mortality occurred within the first 24h of the assay, and effects of P11a/GNA fusion protein were dose dependent, ranging from 100% mortality at 10µg fusion protein / insect to 33% mortality at 1.25µg fusion protein / insect after 24h. Mortality at this lowest dose of fusion protein increased to 67% after 72h whereas mortality from injection of 1.25µg toxin alone / insect did not change from 20% in the period 24-72h. From these assays, the LD₅₀ (48h) for the recombinant P11a/GNA fusion protein was 1.4µg / insect, or

2.8µg / 100mg insect, based on a mean larval weight of 50mg. The LD₅₀ for fusion protein is equivalent to 0.57µg of recombinant P11a toxin per insect, making the fusion protein approx. 7.5 times as active as the recombinant toxin. A similar ratio is obtained by using mortality figures at 72h. Direct comparisons of mortality produced by identical doses of toxin and fusion protein show that the treatments are different from each other, and from control, at $p < 0.0001$ (ANOVA). In all these assays, no mortality of control-injected insects was observed over 72h.

4.3.2 Toxicity of the P11a/GNA fusion protein to cabbage moth larvae after oral delivery

Newly hatched third instar larvae of *M. brassicae* could consume up to 2µl droplets of phosphate buffered saline (PBS) containing 10% w/v sucrose if starved for 24h prior to the experiment. This method was used to deliver recombinant proteins to assay their oral toxicity, by dissolving the protein in the PBS/sucrose solution. Two doses of P11a/GNA fusion protein (20µg and 30µg per droplet) and one dose each of P11a (30µg) and GNA (30µg) were delivered as experimental treatments. Control larvae were fed PBS/sucrose. Results are shown in Fig. 4.10 A.

Effects on mortality caused by the different treatments were observed over the first 6 days of the assay, with no further effects up to day 8; control survival was 100% over this period. All protein treatments caused reduced survival, but the P11a toxin effect was not significant (survival analysis, log rank test), causing only 10% mortality. The effect of GNA, which caused 20% mortality, was just significant ($p = 0.037$). In contrast, both doses of fusion protein caused highly significant effects on survival ($p < 0.01$). A single 30µg dose of the P11a/GNA fusion protein led to complete larval mortality after 6 days, with most mortality occurring in the first 4 days after exposure; the 20µg dose of fusion protein caused 45% mortality. Insects exposed to fusion protein showed partial paralysis, and became lethargic and unresponsive.

Toxic effects were also observed when P11a/GNA fusion protein was fed to larger larvae. Newly eclosed fifth instar larvae fed a single dose of 30µg of P11a/GNA fusion protein showed 35% mortality over 4 days, whereas control larvae

or larvae fed 30µg doses of P11a or GNA exhibited 100% survival (significantly different; $p < 0.0001$). Surviving insects, which had been fed the fusion protein showed strongly retarded growth, increasing their weight only two-fold over 4 days, whereas control insects increased their weight 8-fold (Fig. 4.10 B). Insects, which had been fed P11a or GNA showed no difference in weight gain to the control. The difference in mean larval weight values between fusion-exposed and control, GNA and P11a treatments was highly significant ($P < 0:0001$; ANOVA). The effect of P11a/GNA fusion protein was not the same as starvation, since insects fed no diet showed a weight loss (final weight: initial weight = 0.57) over this period. Instead, oral administration of the fusion protein caused reduced feeding after administration. Insects were transferred back to standard rearing diet, and consumption of diet was measured by decrease in wet weight. The consumption of diet by insects was correlated with their weight gain; larvae fed diet containing fusion protein consumed approx. 10% of the diet consumed by controls over 5 days, whereas consumption by larvae fed P11a or GNA did not differ significantly from controls (result not presented). The reduced diet consumption is consistent with the observation that insects consuming fusion protein became lethargic and unresponsive, even after transfer back to rearing diet.

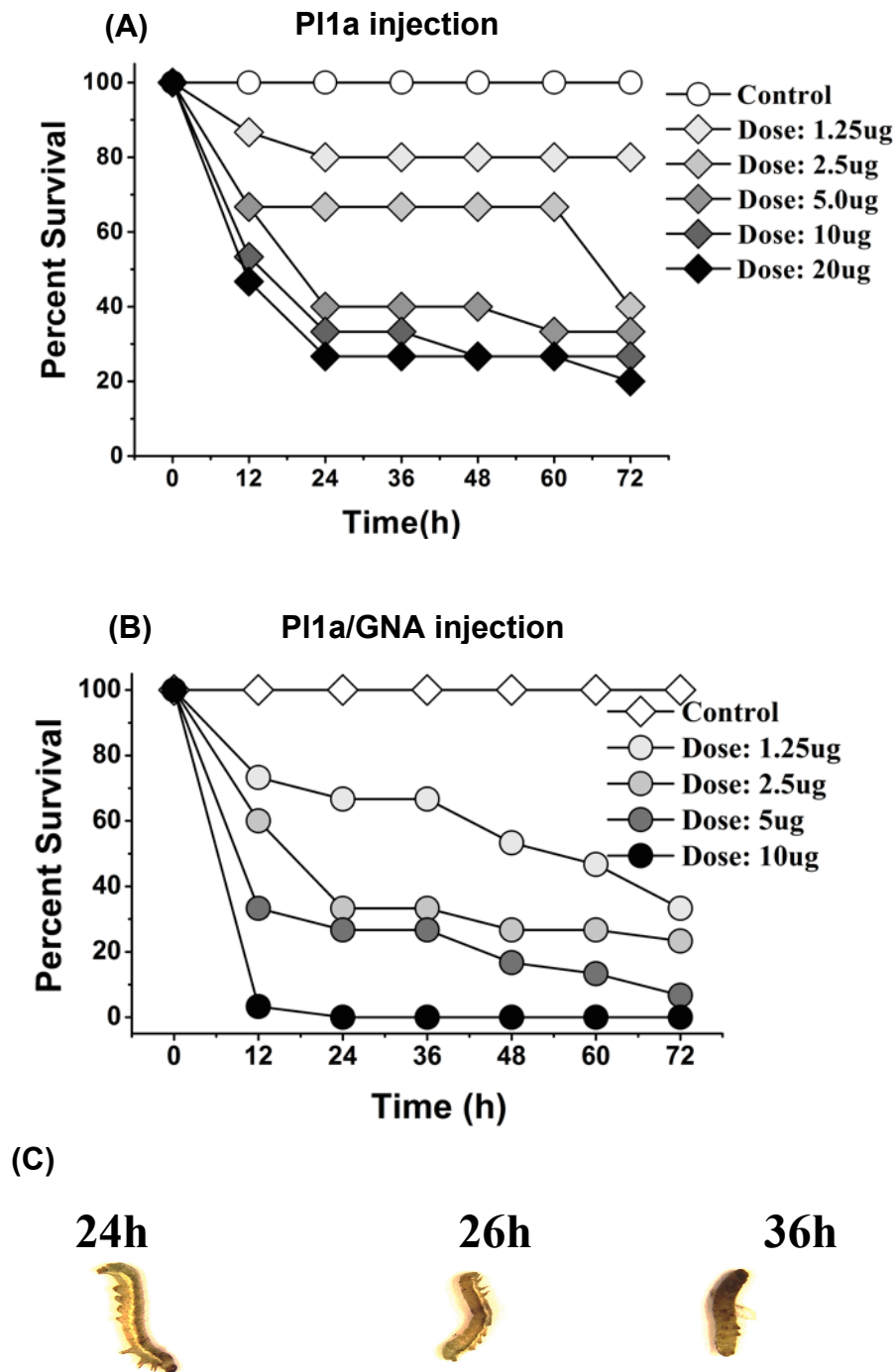

Figure 4.9

Injection bioassays of P11a and P11a/GNA against larvae of cabbage moth (*M. brassicae*). (A) Survival of 5th instar larvae after injection of varying amounts of P11a toxin. (B) Survival of 5th instar larvae after injection of varying amounts of P11a/GNA fusion protein. (C) Phenotype of *M. brassicae* between 24h and 36h when injected with a single dose of P11a/GNA fusion protein (30µg).

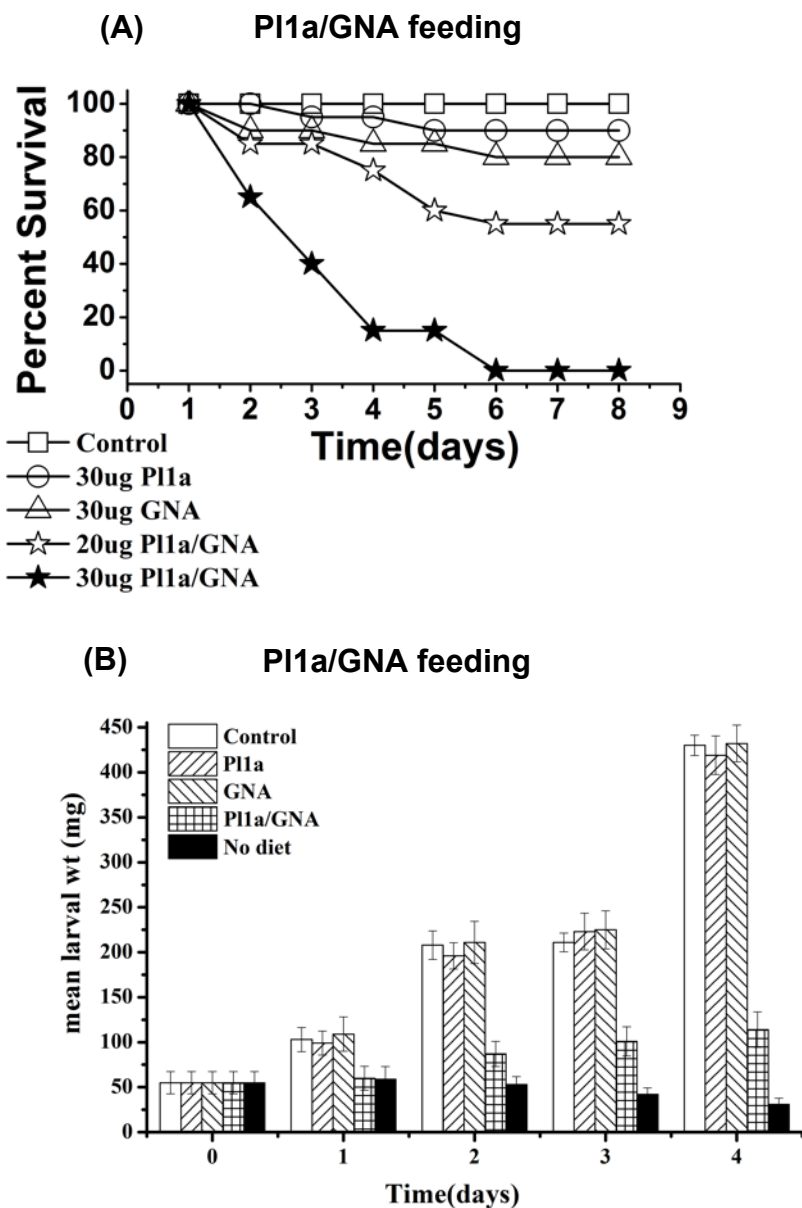

Figure 4.10

Feeding bioassays of P11a and P11a/GNA against larvae of cabbage moth (*M. brassicae*). (A) Survival of 3rd instar larvae after feeding a single dose of P11a (Amaurobitoxin; 30 μ g), snowdrop lectin (GNA; 30 μ g) or P11a/GNA fusion protein (Amaurobitoxin/GNA; dose as indicated). (B) Growth of 5th instar larvae after feeding a single dose of P11a (Amaurobitoxin; 30 μ g), snowdrop lectin (GNA; 30 μ g) or P11a/GNA fusion protein (Amaurobitoxin/GNA; 30 μ g).

4.3.3 Detection of ingested P11a/GNA in cabbage moth larval tissues after oral delivery

To establish that the P11a/GNA fusion protein was capable of getting across the gut in *M. brassicae* larvae, haemolymph was extracted from insects fed on diets containing fusion protein and was analysed for the presence of fusion protein by western blotting, using anti-GNA antibodies (Fig. 4.11 A). Insects were starved, given a single 20 μ g dose of P11a/GNA in liquid diet, and then returned to normal rearing diet, so the experiment is essentially a "pulse-chase". The blot confirmed that intact P11a/GNA fusion protein was present in treated insects after 2h, whereas control insects showed no immunoreactive material. The western blot showed evidence for partial proteolysis of the P11a/GNA fusion protein, with increased levels of a band corresponding in size to GNA being visible on the blots in comparison to purified fusion protein; the sample taken 4h after feeding the protein shows a "GNA" band comparable in intensity to the fusion protein bands, whereas in the purified protein the "GNA" band is present only at very low intensity compared to the fusion protein bands. The time course of accumulation of fusion protein in the haemolymph gave an unexpected result in that levels of P11a/GNA in the haemolymph increased from the 2h after feeding sample to 4h, but the haemolymph sample taken 6h after feeding contained only very small amounts of P11a/GNA compared to the 4h sample; this result was reproducible over different feeding experiments. Samples taken at later times (24 -72h) showed fusion protein presented in haemolymph at higher levels than at 6h after feeding.

One destination of P11a/GNA fusion protein delivered to the haemolymph was the central nervous system, the site of action of the toxin. This was shown by dissection of nerve chords from insects after feeding, and analysis by western blotting (Fig. 4.11 B). Proteins extracted from nerve chords showed immunoreactivity with anti-GNA antibodies, at a level that increased from 2-4h after feeding, and then remained similar for up to 24h. The immunoreactive bands indicated a higher level of intact fusion protein than GNA. Levels of fusion protein in the nerve chord then declined from 24h-72h after feeding. This accumulation of GNA-based neurotoxic fusion proteins on the nerve chord of insects has been observed previously by direct visualisation using labelled proteins (Fitches et al.,

2012). Further examination of tissues from insects fed a "pulse" of P11a/GNA fusion protein confirmed the disappearance of immunoreactive bands from gut and haemolymph 6h after feeding, and a reappearance of the fusion protein and GNA after 24h, first in the haemolymph at 24h after feeding and then in the gut at 48h and 72h after feeding (Fig. 4.11 C). These results suggest that the P11a/GNA fusion protein initially binds to nervous tissue, but is subsequently released back into the haemolymph, and subsequently reassociates with gut tissue. In a confirmatory experiment, P11a/GNA fusion protein was injected into the haemolymph of *M. brassicae* larvae at sub-lethal levels, and was detected in different tissues after 4h (Fig. 4.11 D). P11a/GNA was found associated with gut tissue and Malpighian tubules; a small amount of protein was also present in fat body. No evidence of proteolytic cleavage of this material to GNA was observed, confirming that haemolymph contains low levels of proteolytic activity. However, in the feeding assay, it showed more breakdown of fusion protein from 2h to 4h (Fig. 4.11 A). This happened in the process of transporting across the gut to haemolymph because much proteolytic enzymes exit in the gut.

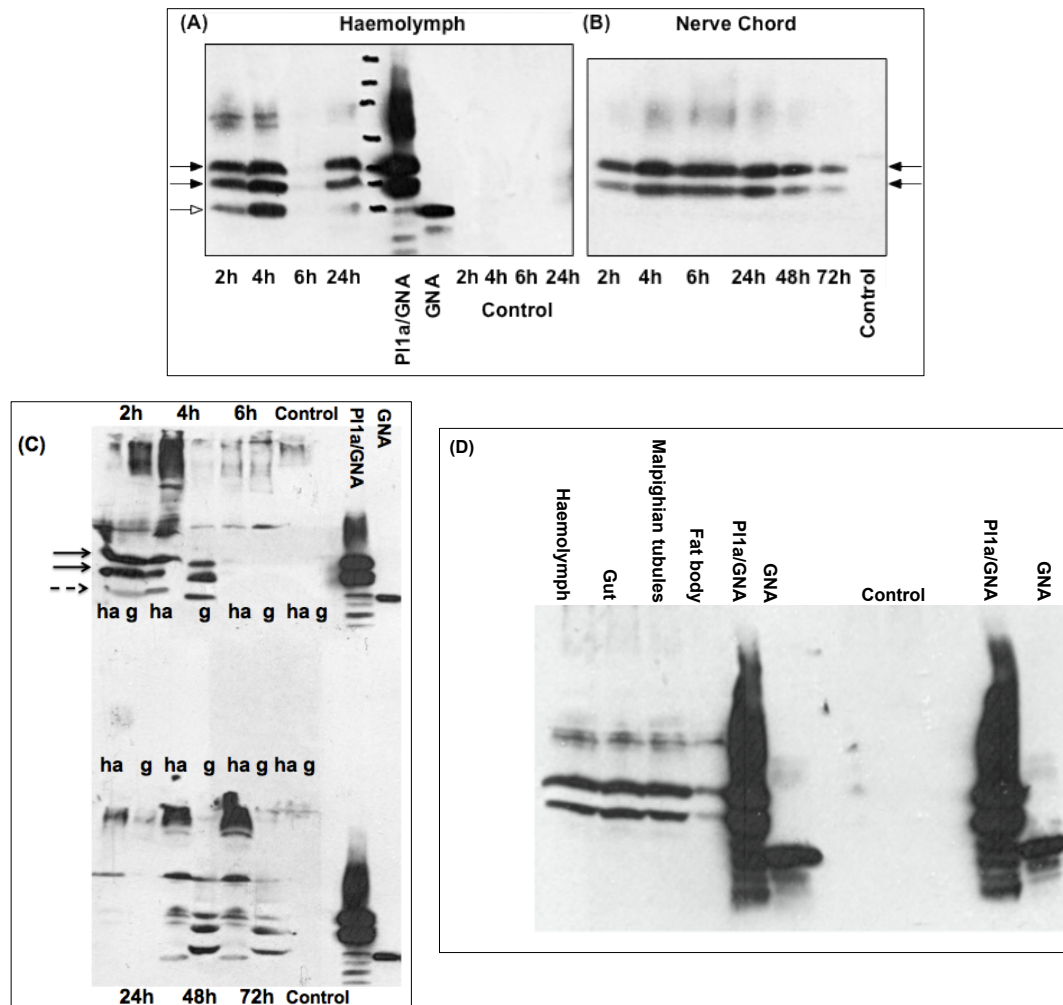

Figure 4.11

Transport of P11a/GNA fusion protein from gut contents to haemolymph, Malpighian tubules, fat body and nerve chord in larvae of cabbage moth (*Mamestra brassicae*). Larvae were injected or fed a single dose of P11a/GNA fusion protein, and tissues were sampled at the indicated time after feeding. The presence of P11a/GNA fusion protein was visualised by SDS-PAGE analysis of extracted proteins, followed by western blotting using anti-GNA antibodies. **(A)** Haemolymph from treated and control insects after feeding. **(B)** Nerve chords from treated and control insects after feeding. **(C)** The trace of P11A/GNA in the gut and haemolymph after 2h, 4h, 6h, 20h, 24h and 48h, respectively after feeding. ha, haemolymph; g, gut. **(D)** The trace of P11A/GNA after injection to hemolymph of *M. brassicae* larvae after 4h. Lane 1, haemolymph; Lane 2, gut; Lane 3, Malpighian tubules; Lane 4, fat body.

4.3.4 Toxicities of recombinant Ao1bPro-P11a; Ao1bPro-P11a/GNA and Hv1aPro-P11a/GNA fusion proteins to cabbage moth larvae after injection into the haemolymph

Recombinant P11a produced from the modified expression construct, including the Pro-region from U3-agatoxin-Ao1b, showed similar toxic effects to P11a, but was consistently more effective at lower doses than P11a produced from the construct without this additional sequence (Fig. 4.12 A). Again, the major effects on mortality were observed during the first 24h of the assay, with mortality ranging from 80% at 10µg toxin / insect to 30% at 1.25µg toxin / insect. In these assays, there was a trend for mortality caused by toxin produced by the modified construct to continue to increase to 72h, and the highest dose of toxin (10µg toxin / insect) caused 100% mortality at 72h. Assays carried out at the same time with P11a produced by the unmodified construct gave similar results to the previous assay, and direct comparison between the two samples in the same assay showed that differences between P11a produced by the unmodified and modified constructs were statistically significant when identical dose survival curves were analysed ($p < 0.0001$) (Fig. 4.12 A). The LD₅₀ (48h) for recombinant P11a produced from the modified construct (Ao1bPro-P11a) was approx. 1.0µg / insect, or 21µg / g insect based on a mean larval weight of 50 mg; this is equivalent to an increase in toxicity of approx. 4-fold.

As observed with P11a toxin, addition of the Ao1b Pro-region to the fusion protein expression construct resulted in a protein product with enhanced biological activity (Fig. 4.12 B). The fusion protein product derived from this construct had an LD₅₀ (48h) of 0.94 µg / insect, with increased mortalities at all doses except the highest. Addition of an unrelated Pro-region, that from the HV1a toxin, to the expression construct also enhanced the biological activity of the resulting fusion protein (Fig. 4.12 C); this protein had an LD₅₀ (48h) of <0.6 µg / insect, although overall mortality values were similar to the Ao1bPro-P11a / GNA fusion protein. From these data (data summarized in Table 1), the increase in toxicity caused by including Pro-regions from toxins in the expression constructs for P11a / GNA was approximately 2-fold.

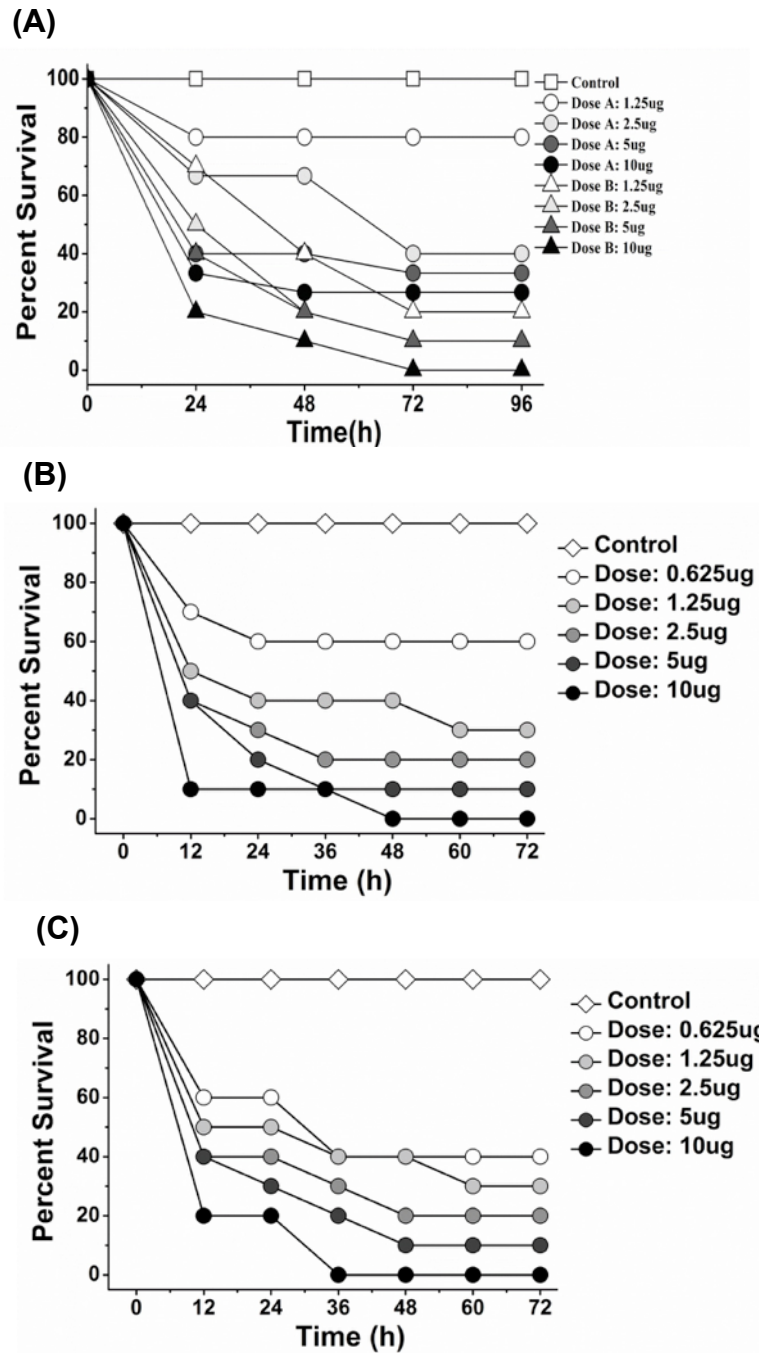

Figure 4.12
Survival of fifth stadium *M. brassicae* larvae following injection of different doses of (A) Ao1b-ProP11a (Dose A: P11a; Dose B: Ao1bPro-P11a) (B) Ao1b-ProP11a/GNA and (C) Hv1aPro-P11a/GNA. Proteins in all cases were dissolved in 1×PBS solutions. Injection volume was 5µl. Control larvae were injected 5µl 1×PBS solution without dissolved proteins. N=20 per treatment.

Table 4.1

Toxicity of Recombinant Toxins and Fusion Proteins in Injection Bioassays with Lepidopteran (*Mamestra brassicae*) Larvae (P11a, Ao1bPro-P11a, P11a/GNA, Ao1bPro-P11a/GNA and Hv1aPro-P11a/GNA). Each bioassay was repeated 3 times.

P11a (literature)	P11a	Ao1bPro-P11a	P11a in P11a/ GNA	P11a in Ao1bPro-P11a/ GNA	P11a in Hv1aPro-P11a/GNA
9.5µg/g (<i>Spodoptera</i>)	82µg/g	21µg/g	11µg/g	7.6µg/g	>5µg/g

Notes: Figures are for the LD₅₀ of P11a component at 48h, with *M. brassicae* larvae unless otherwise noted. Per gram means per gram larvae.

4.3.5 Toxicities of Ao1bPro-P11a/GNA and Hv1aPro-P11a/GNA fusion proteins to cabbage moth larvae after oral delivery

A similar increase in toxicity of fusion proteins derived from expression constructs including Pro-regions to that observed in injection assays was also observed in droplet feeding assays with 3rd stadium *M. brassicae* larvae (Fig. 4.13). Following ingestion of a single 2 μ l droplet containing 20 μ g of fusion protein, mortality after 5 days was 40 % for P11a/GNA, 50 % for Ao1bPro-P11a/GNA and 70 % for Hv1aPro-P11a/GNA (data summarized in Table 2). Minimal reductions in survival (0-20%) were observed for control treatments where larvae were fed on 30 μ g of the toxin or GNA, and survival curves for controls were significantly different to fusion protein treatments. This provides further evidence that the addition of Pro-regions to the P11a/GNA construct results in increased biological activity. As for injection studies, the use of the Hv1a Pro-region was seen to result in the greatest enhancement of toxicity over the non-modified P11a/GNA fusion protein.

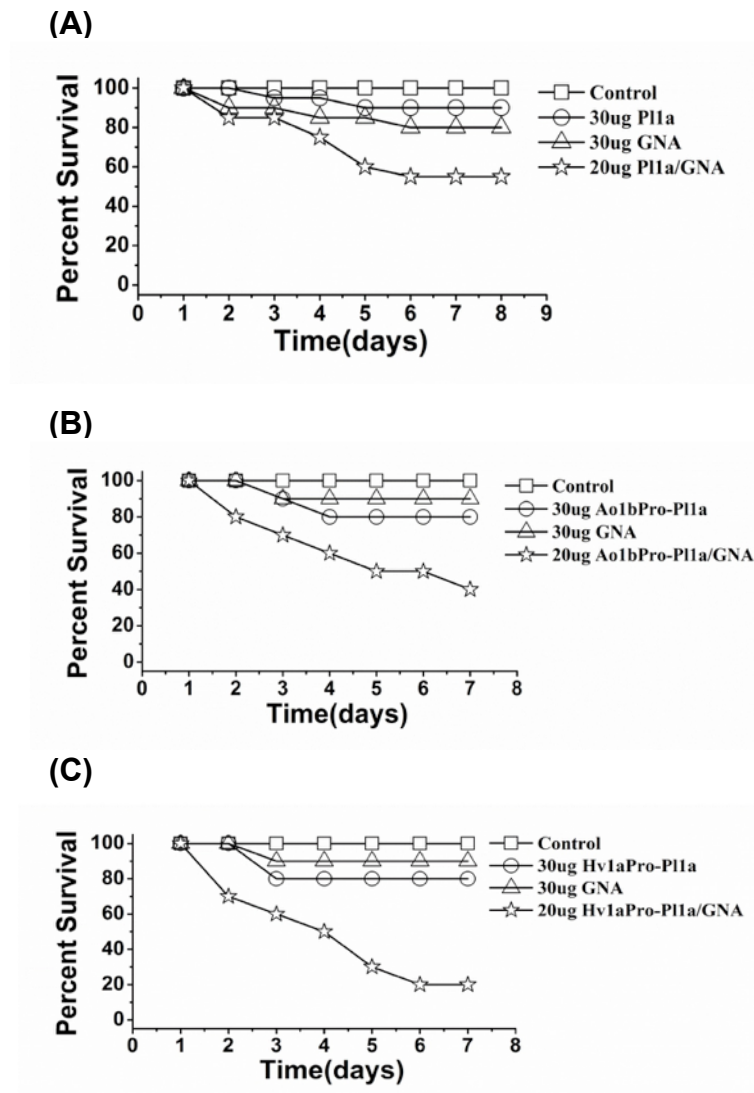

Figure 4.13

Ingestion toxicity of recombinant P11a/GNA, Ao1bPro-P11a/GNA and Hv1aPro-P11a/GNA to *Mamestra brassicae*. Percentage survival of 3rd instar *Mamestra brassicae* larvae following ingestion of a single 2 μ l 1 \times PBS droplet containing 20 μ g of purified P11a/GNA and 20% sucrose (w/v) **(A)**, Ao1bPro-P11a/GNA **(B)** or Hv1aPro-P11a/GNA **(C)** fusion proteins. Blank controls in all cases were fed 2 μ l 1 \times PBS droplet containing only 20% sucrose (w/v) without any toxin protein. The component control was fed 2 μ l 1 \times PBS droplet containing 30 μ g of purified P11a, Ao1bPro-P11a or GNA, respectively and 20% sucrose (w/v).

Table 4.2

Toxicity of Recombinant Toxins and Fusion Proteins in Oral Feeding Bioassays with Lepidopteran Larvae (*Mamestra brassicae*). Abbreviations as in Table 4.1.

Each bioassay was repeated 3 times.

P11a (literature)	P11a (recombinant)	Ao1bPo-P11a	P11a/ GNA	Ao1bPro-P11a/GNA	Hv1aPro-P11a/ GNA
ND	90% 5d 750µg/g	80% 5d 750µg/g	60% 5d 500µg/g	50% 5d 500µg/g	30% 5d 500µg/g

Notes: Figures are for survival % over 5 days; 3rd instar larvae (mean weight 40 mg) fed a single droplet giving the stated dose of fusion protein. Per gram means per gram larvae.

4.4 Effects of recombinant P11a toxin, P11a/GNA, Ao1bPro-P11a/GNA and Hv1aPro-P11a/GNA fusion proteins on houseflies

4.4.1 Toxicities of recombinant P11a toxin and P11a/GNA fusion proteins to houseflies

Bioassays using houseflies were carried out on adult insects, which could be injected using basic equipment without causing high levels of mortality. These assays showed that both the recombinant P11a toxin and the P11a/GNA fusion protein caused paralysis and mortality when injected. Typical results are shown in figs. 4.14 A and 4.14 B. Mortality was dose dependent, with most insects' deaths taking place in the first 72h after injection. A dose of 1.0 μ g of recombinant P11a caused 100% mortality in 72h and doses \geq 0.5 μ g caused 100% mortality in 144h. The data gave an LD₅₀ (72h) of 0.18 μ g P11a per insect, or approx. 1.8 μ g P11a per 100mg insect, based on an average adult weight of approx. 10mg. The P11a/GNA fusion protein was significantly more effective than the recombinant toxin, with more rapid mortality at lower doses; at a dose of 0.24 μ g per insect, 100% mortality was observed after 24h. The LD₅₀ (72h) for the fusion protein was 0.045 μ g per insect, or approx. 0.45 μ g fusion protein per 100mg insect; this is equivalent to 0.18 μ g of P11a, making the fusion protein 10 times as effective as the recombinant toxin alone on a mole-for-mole basis. The P11a/GNA fusion protein was also an effective toxin when fed to adult *M. domestica* (Fig. 4.14 C); a 0.25 μ g/ μ l solution caused 100% mortality in 72h, whereas 0.125 μ g/ μ l solution caused 70% mortality. Flies were completely paralysed approx. 2h after feeding, and most paralysed insects subsequently died (Fig. 4.14 D). Higher concentrations of the fusion protein caused lower mortality over 6 days, as the insects would not feed, or fed only very little; the chambers were moist enough to allow insects to survive without feeding.

Attempts to inject larvae of *M. domestica* also showed that both the toxin P11a and the P11a/GNA fusion protein were effective toxins, but control survival in these assays was erratic due to damage from the injection (data not shown). Larvae could not be induced to feed on material containing recombinant proteins in the feeding assays (data not shown).

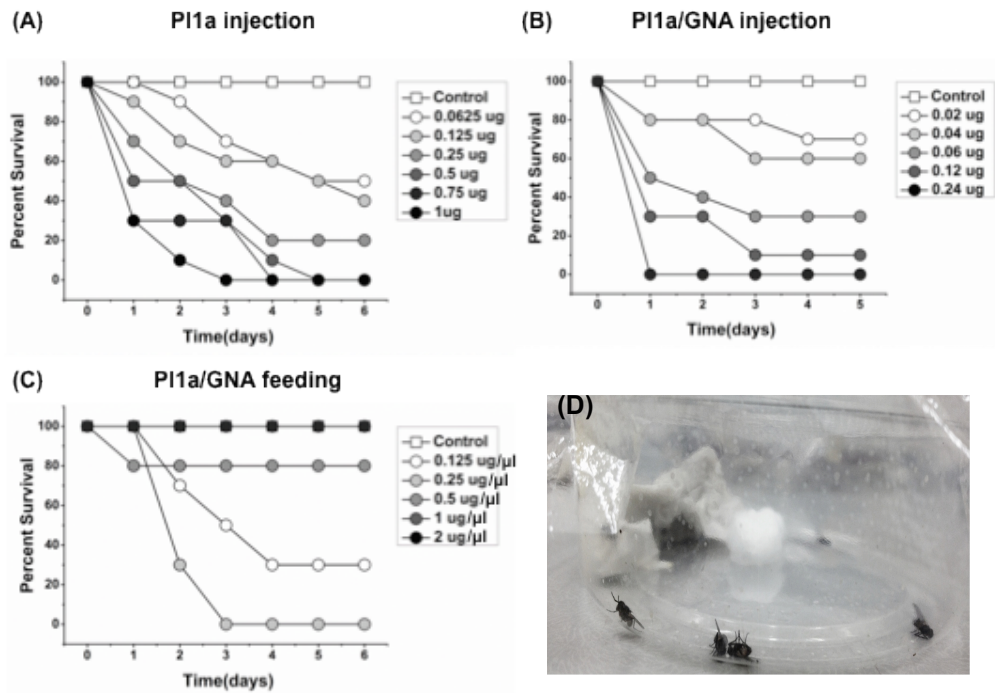

Figure 4.14

Bioassays of P11a and P11a/GNA against adults of housefly (*Musca domestica*).

(A) Survival of adult flies after injection of varying amounts of P11a toxin. (B) Survival of adult flies after injection of varying amounts of P11a/GNA fusion protein. (C) Survival of adult flies allowed to feed *ad libitum* on solutions containing P11a/GNA fusion protein (P11a/GNA; concentration as indicated). (D) Mortality of flies when injected with 0.125-0.25 μg/μl P11a/GNA.

4.4.2 Toxicities of Ao1bPro-P11a/GNA and Hv1aPro-P11a/GNA fusion proteins to houseflies

The P11a/GNA fusion protein was an effective toxin when fed to adult *M. domestica*. Here, the Ao1bPro-P11a/GNA and Hv1aPro-P11a/GNA fusion proteins were fed to adult *M. domestica* to test their toxicity (Fig. 4.15 A, B, C and D). A 0.25µg/µl Ao1bPro-P11a/GNA solution containing 50%-60% sucrose caused 100% mortality on the fifth day, whereas 0.125µg/µl solution caused 70% mortality. This result was very similar to that of effect of P11a/GNA on flies. From the assay, the LD₅₀ (72h) for the recombinant Ao1bPro-P11a/GNA was 0.1µg/µl per fly (Fig. 4.15 A). The toxicity of Hv1aPro-P11a/GNA was a little higher than that of Ao1bPro-P11a/GNA. A 0.25µg/µl Hv1aPro-P11a/GNA solution containing 50%-60% sucrose caused 100% mortality just on the fourth day. Moreover, 0.125µg/µl Hv1aPro-P11a/GNA solution caused 80% mortality, 10% more than 0.125µg/µl Ao1bPro-P11a/GNA solution. The LD₅₀ (the fifth day) for the recombinant Hv1aPro-P11a/GNA was 0.0625µg/µl per fly (Fig. 4.15 B). Flies were completely paralysed approx. 2h after feeding, and most paralysed insects subsequently died (Fig. 4.15 A, B). Interestingly, when Ao1bPro-P11a/GNA or Hv1aPro-P11a/GNA fusion protein was dissolved in the solution containing 10-20% sucrose, most flies would not feed and stayed away from the solution. Therefore, they could survive for a longer time than the groups of solutions containing 50-60% sucrose (Fig. 4.15 C and D). A 0.25µg/µl Ao1bPro-P11a/GNA solution containing 10%-20% sucrose only caused 20% mortality on the fifth day. In contrast, 0.25µg/µl solution containing 50%-60% sucrose caused 100% mortality (Fig. 4.15 A and C). On the contrary, 0.0625µg/µl Ao1bPro-P11a/GNA solution containing 10%-20% sucrose could lead to 50% death (Fig. 4.15 A), which meant higher concentrations of the fusion protein dissolved in the solutions just containing 10%-20% sucrose caused lower mortality over 6 days, as the insects would not feed, or fed only little; the chambers were moist enough to allow insects to survive without feeding. Similar result was also obtained from the bioassay of Hv1aPro-P11a/GNA dissolved in the solutions containing 10%-20% sucrose when delivered to adult fly (Fig. 4.15 D). A 0.25µg/µl Hv1aPro-P11a/GNA

solution containing 10%-20% sucrose caused 60% mortality on the fifth day, whereas A 0.25 μ g/ μ l Hv1aPro-P11a/GNA solution containing 50%-60% sucrose caused 100% mortality. A 0.125 μ g/ μ l Hv1aPro-P11a/GNA solution caused 10% mortality on the fifth day, which also showed the fusion proteins dissolved in the solutions containing little sucrose caused lower mortality, as the flies would not feed, or fed only very little (Fig. 4.15 D). It may be that high sugar concentrations mask the “taste” of the solution resulting in the flies consuming more of the fusion protein as compared to flies fed on low sugar solutions that show reduced feeding.

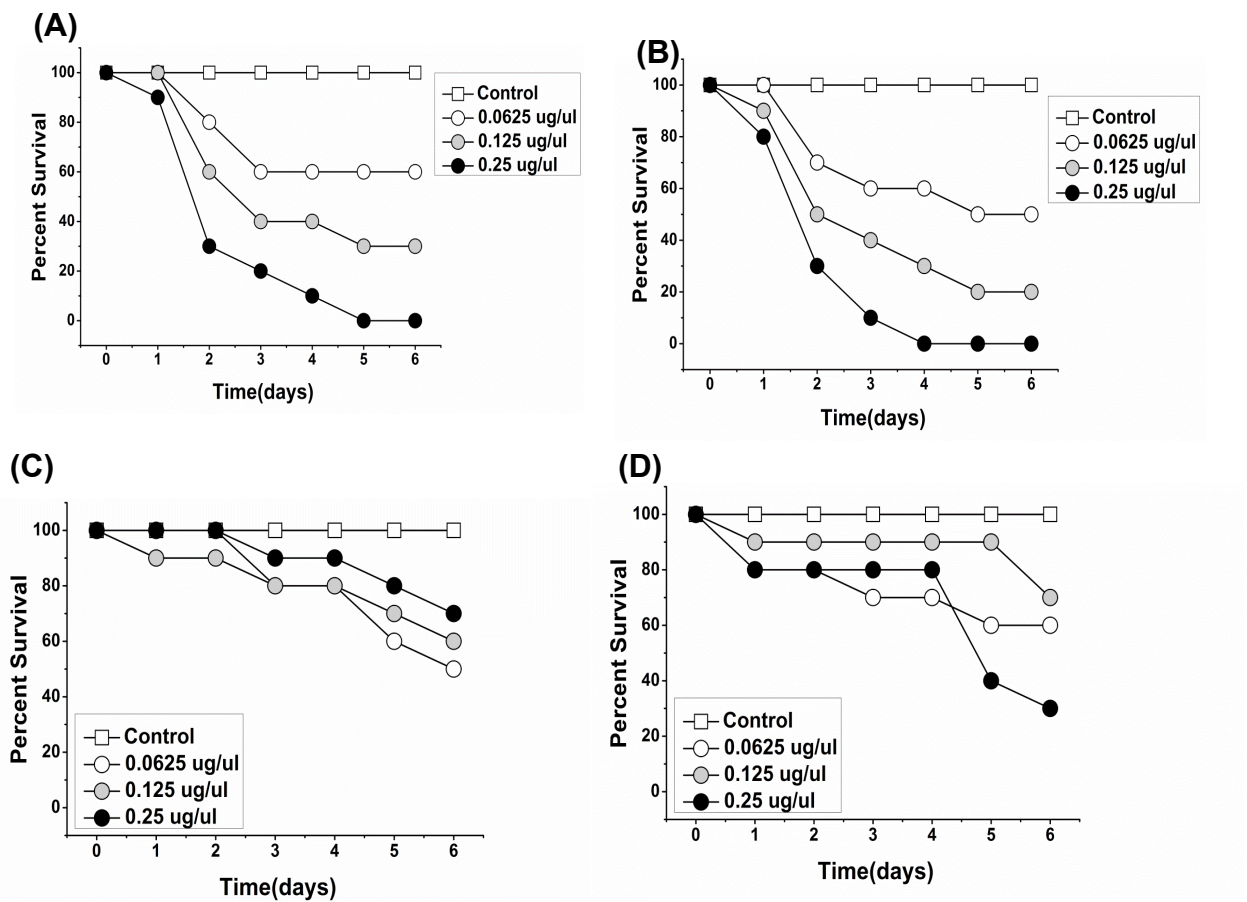

Figure 4.15

Bioassays of Ao1bPro-P11a/GNA and Hv1aPro-P11a/GNA fusion proteins against *M. domestica*. Survival of adult flies following the oral delivery 1×PBS solutions containing (A) 50-60% sucrose and different concentrations of Ao1bPro-P11a/GNA fusion protein (B) 50-60% sucrose and different concentrations of Hv1aPro-P11a/GNA fusion protein (C) 10-20% sucrose and different concentrations of Ao1bPro-P11a/GNA fusion protein (D) 10-20% sucrose and different concentrations of Hv1aPro-P11a/GNA fusion protein. Blank controls in all cases were fed 1×PBS droplet containing only sucrose without any toxin protein.

4.5 Effects of oral delivery of P11a/GNA fusion protein on pea aphids

Purified recombinant P11a, P11a/GNA fusion protein and recombinant GNA were fed to *A. pisum* nymphs by incorporation into artificial diet at a range of concentrations (Fig. 4.16 A). Survival and growth of the insects were monitored. Aphids feeding on 1.0 mg/ml P11a/GNA fusion protein showed 100% mortality after 3 days of feeding, which was significantly different to negative controls, whereas aphids feeding on diet containing 0.24 mg/ml P11a or 0.76 mg/ml GNA showed only 53.3% or 33.3% mortality in 7 days of feeding compared with 1.0 mg/ml P11a/GNA. Moreover, feeding a mixture of P11a (0.24 mg/ml) and GNA (0.76 mg/ml), which was equivalent to 1 mg/ml P11a/GNA fusion protein in the content, showed 83.3% mortality in 7 days of feeding whereas 1 mg/ml P11a/GNA indicated 100% mortality in 3 days. The fusion protein survival curve was significantly different to controls and other treatments ($p < 0.001$). The aphids fed on fusion protein containing diets also showed reduced growth as compared to controls. Image J analysis of aphid sizes showed a reduction of approx. 60% as compared to controls, but differences between treatments were not significant ($p < 0.01$) (Fig. 4.17 A and B).

Feeding P11a/GNA at different concentrations from 0.25 mg/ml to 1 mg/ml showed a dose dependent effect on *A. pisum* survival. After 7 days of feeding, 1.0 mg/ml P11a/GNA caused 100% mortality whereas the lowest concentration of P11a/GNA, 0.25 mg/ml, produced approx. 10% mortality. From 0.5 mg/ml to 1 mg/ml, all survival curves for P11a/GNA were significantly different to negative controls, and aphid growth was significantly reduced. However, the size of 0.25 mg/ml P11a/GNA-fed aphids was not significantly different to control aphids, suggesting that the aphids were capable of overcoming the growth retardation effects of 0.25 mg/ml P11a/GNA.

To demonstrate binding of proteins to the aphid gut surface, recombinant P11a, GNA and P11a/GNA fusion protein were labelled by conjugation with fluorescein, and fed in diet to aphids at a sub-lethal concentration (0.8 mg/ml P11a, 1 mg/ml GNA and 0.64 mg/ml P11a/GNA) for 24h. The label was then “chased” by allowing aphids to feed on control diet for 24 h and 48 h. Labelled proteins were detected in whole insects by fluorescence microscopy, and were readily detectable in insects

with no chase after feeding. Results are presented in Fig. 4.16 B. Fluorescein, used as a negative control, (Fig. 4.16 B, panel 24), was eliminated completely from the aphid gut after 48h chase, whereas fluorescein-labelled GNA, used as a positive control, was still present in the gut after 48h chase. As expected, the labelled P11a/GNA fusion protein also persisted in the midgut region of aphids, and was easily detectable even after 48h chase (Fig. 4.16 B, panel 12). Surprisingly, labelled recombinant P11a could also bind to the gut (Fig. 4.16 B, panels 16-17), and was detectable after 24h chase, although the level of binding after 48h chase decreased to undetectable, (Fig. 4.16 B panel 18), in contrast to labelled GNA and P11a/GNA, which were readily detectable after 48h chase. These results showed that although recombinant P11a, GNA and P11a/GNA could all bind to the aphid gut, recombinant P11a was most readily removed, suggesting weaker binding.

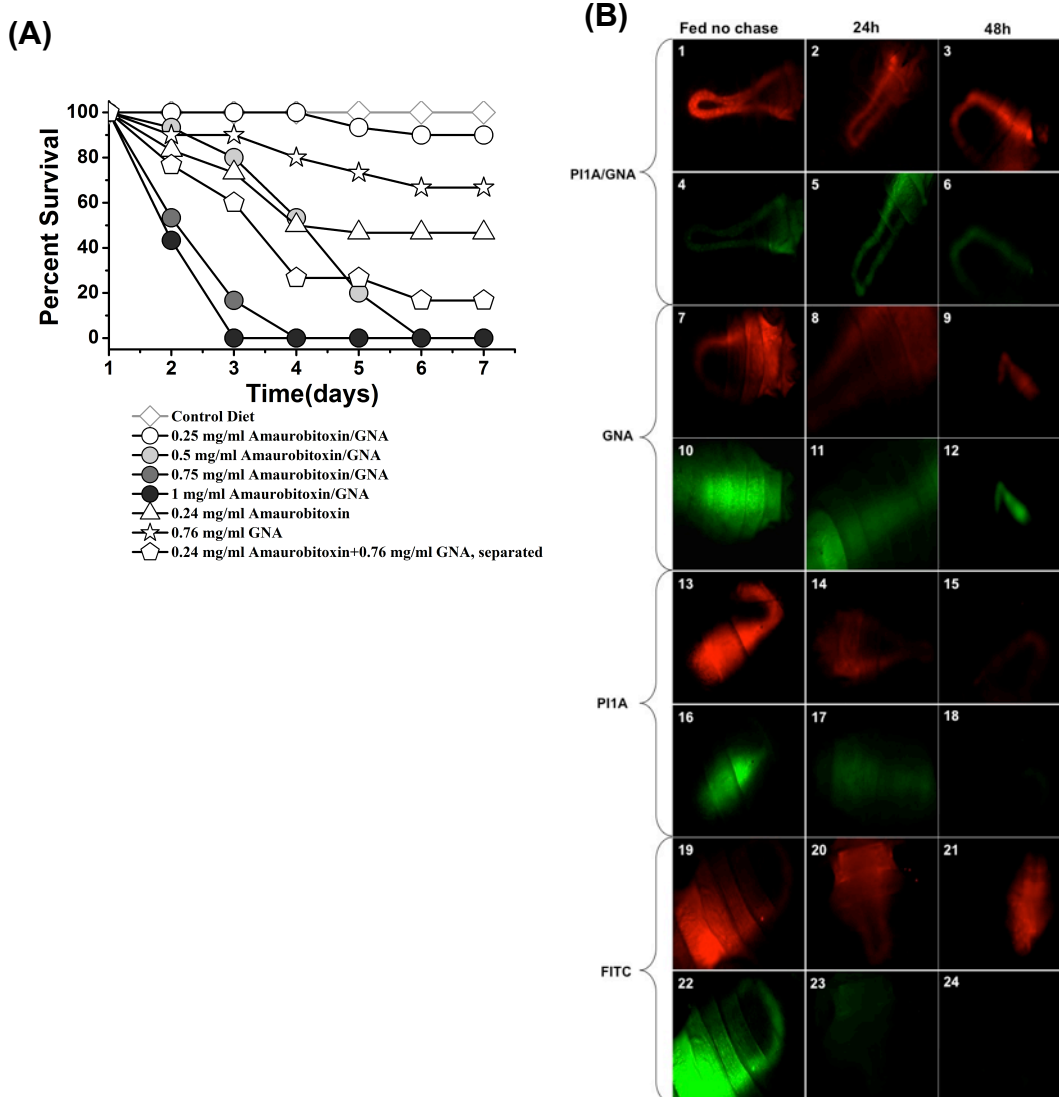

Figure 4.16

Bioassays of P11a/GNA fusion protein against nymphs of pea aphid (*Acyrthosiphon pisum*). (A) Survival of aphids on diets containing P11a (Amaurobitoxin), snowdrop lectin (GNA) or P11a/GNA fusion protein (Amaurobitoxin/GNA) at concentrations as indicated. (B) Feed-chase experiment to show binding of proteins to aphid gut. Diets containing recombinant proteins labelled with FITC were fed to aphids for 24h. Subsequently the label was "chased" with control diet for times as indicated. Red fluorescence indicates the aphid gut, green fluorescence indicates labelled proteins. GNA and P11a/GNA could both bind to the aphid gut until 48h chase. P11a was readily removed after 24h chase, suggesting weaker binding. FITC control was no signal before 24h, suggesting no binding.

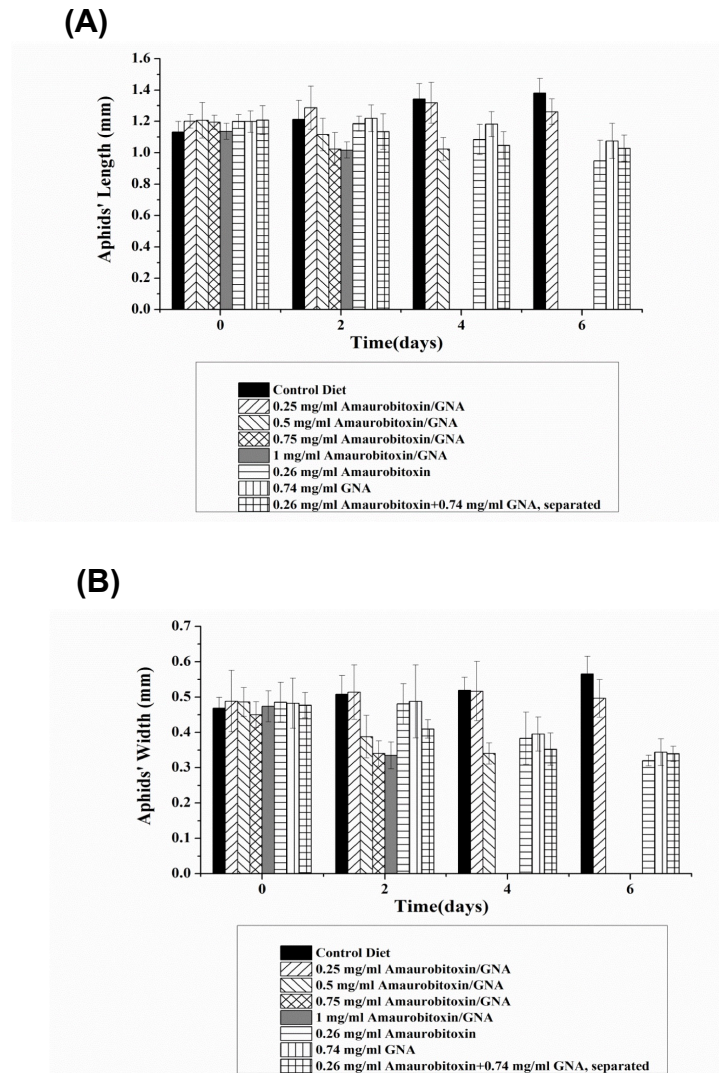

Figure 4.17

Aphids' size after exposure for 6 days from neonate to diets containing P11a (Amaurobitoxin), snowdrop lectin (GNA) or P11a/GNA fusion protein (Amaurobitoxin/GNA) at concentrations as indicated. (A) Aphids' length. (B) Aphids' width.

Discussion

Proteolysis of fusion proteins produced in *P. pastoris* during secretion, or in the culture medium, or during purification, has been a significant problem with previous toxin/GNA fusions (Fitches et al., 2004), resulting in the final product containing significant amounts (up to 50%) of cleaved GNA. However, the P11a/GNA fusion protein is relatively resistant to proteolysis, and the purified product contains only small amounts of free GNA. Moreover, *P. pastoris* has an efficient N-glycosylation system for proteins which pass through the ER, although in most cases core glycosylation with a branched oligomannose structure is only elaborated by addition of extra mannose residues (Bretthauer and Castellino, 1999). The recombinant P11a and Ao1bPro-P11a toxins; the P11a/GNA, Ao1bPro-P11a/GNA and Hv1aPro-P11a/GNA fusion proteins all contain N-glycosylation sites, corresponding to the sequence -NNS- at the C-terminus of the mature toxin. However, only the fusion protein shows evidence of glycosylation at this site. Utilization of an N-glycosylation site requires the amino acid residues to be accessible to the glycosylating enzyme(s), and not all sites are used. The difference in glycosylation properties of the recombinant toxin and fusion protein is evidence for differences in folding and accessibility in this region of the toxin.

Both the recombinant toxins P11a and Ao1b-P11a show insecticidal activity on injection into Lepidopteran and Dipteran insects, with the expected symptoms of paralysis and mortality. The LD₅₀ value of Ao1b-P11a (21µg/g insect) is much lower than that of P11a (82µg/g insect) against *M. brassicae* larvae, which demonstrates the importance of the synthetic homologous Pro-region in the processing of P11a peptide folding, even if Ao1bPro-region is not cleaved by enzymes in the yeast cell. Hence, without addition of N-terminal Ao1bPro-region to the P11a expression construct, maybe only a small percentage of recombinant P11a peptide is correctly matured and active during yeast modification. In the injection assays, the fusion protein P11a/GNA has an activity at least 6-fold higher on a molar basis than the recombinant toxin P11a against Lepidopteran and Dipteran insects. There is some evidence from injection bioassays to suggest that the recombinant toxin has lower insecticidal activity than expected. The LD₅₀ for recombinant toxin alone observed

in the injection bioassays against *M. brassicae* larvae, 4.1 µg / insect, or 12 nmoles / g insect is approx. 5-fold higher than the quoted literature value for purified and synthetic P11a toxins of 2.35 nmoles / g insect for larvae of *Spodoptera litura* [LD₅₀ (48h) = 9.5 µg/g insect; Corzo et al., 2000]. In contrast, the LD₅₀ for the recombinant fusion protein P11a/GNA is lower than this literature value for purified toxin when expressed on a molar basis; 28 µg /g insect for P11a/GNA is equivalent to 1.6 nmoles/g insect. If it is assumed that larvae of the two Lepidopteran species have similar susceptibility to the P11a, then these data would suggest that the toxin in the P11a/GNA fusion protein has the expected biological activity, whereas the recombinant toxin alone does not. Two possibilities can be advanced to explain this observation. First, fusion to GNA could assist toxin folding during production as a recombinant protein, leading to a product with more biological activity. Secondly, the carbohydrate-binding activity of GNA enables it to act as an anchor to bind toxin to nerve tissue and increase its local concentration, leading to a higher effective dose. The evidence from western blotting showing high levels of fusion protein associated with nerve chord tissue supports this hypothesis. The results presented here, in agreement with previous data (Fitches et al., 2012), show that fusion to GNA can enhance recombinant toxin biological activity. Moreover, the LD₅₀ for both the recombinant fusion protein Ao1bPro-P11a/GNA (7.6 µg /g insect on a molar basis) and Hv1aPro-P11a/GNA (7.2 µg /g insect on a molar basis) are lower than that for P11a/GNA (11.4 µg /g insect on a molar basis), which also implies P11a peptide (addition of synthetic Pro-regions), when fused to GNA as Pro-P11a/GNA, still able to reach better biological activity than P11a/GNA without addition of Pro-region, although the synthetic Pro-regions may not work as well as the native Pro-region of P11a (sequence unknown). Furthermore, the KEX2 enzyme in the yeast can recognize the synthetic Pro-region site and cleaved it precisely during the process of modification. In molecular terms, Kex2 Protease has the ability to cleave at the carboxyl end of the recognition sequences: Arg-Arg/X, Lys-Arg/X and Arg-Pro/X thus provides possibilities to cleave the C-terminus of Pro-region that normally contains the conserve sequences of Lys...Arg/X (Hopkins et al., 1999).

The droplet feeding assays provide clear evidence of the oral toxicity of the P11a/GNA, Ao1bPro-P11a/GNA and Hv1aPro-P11a/GNA fusion proteins towards Lepidopteran insects. That the insecticidal activity of Pro-P11a/GNA is still a little higher than that of P11a/GNA against *M. brassicae* larvae also demonstrates Pro-regions can facilitate the proper folding of fusion proteins. However, as for Dipteran insects, the activities of Ao1bPro-P11a/GNA and Hv1aPro-P11a/GNA fusion proteins against *M. domestica* were similar to that of P11a/GNA when fed to adult *M. domestica*. Here, it appears that synthetic homologous or heterologous Pro-regions did not improve the toxicity of P11a/GNA against adult houseflies. This may be because the flies would not feed or feed less on Ao1bPro-P11a/GNA and Hv1aPro-P11a/GNA as compared to P11a/GNA containing solutions. In the feeding assays no significant toxicity of the toxin alone, and only marginal effects from the GNA carrier were observed, in agreement with previous assays in which GNA was fed to larvae of tomato moth, *L. oleracea* (Fitches et al., 2001). Only the fusion protein was tested against *M. domestica* adults, but previous results have shown that GNA alone has only limited toxicity at high doses (Fitches et al., 2009). The resistance to proteolysis shown by the P11a/GNA fusion protein, observed during production and purification, is likely to be a factor in its oral toxicity; a high proportion of the GNA transported across the gut will be fused to the toxin, resulting in efficient transport of toxin into the haemolymph. However, some cleavage of fusion protein to release GNA does occur in the larval gut, since higher levels of free GNA are present in the gut after feeding. It is known that high levels of proteolytic activity are present in the larval gut of *M. brassicae* (Chougule et al., 2008). Fusion protein injected into the haemolymph remains intact for up to 24 hours suggesting that this fusion protein is relatively stable in the circulatory system.

The western blotting experiments show transport of intact fusion protein into the haemolymph, and accumulation on nervous tissue; after feeding a single dose, fusion protein initially accumulates in the haemolymph, and then clears after 6h. The subsequent reappearance of fusion protein in haemolymph after 24h is most likely to be due to release from nervous tissue that is being degraded, as a result of partial or complete inactivation due to the toxin. Although the initial transport of fusion protein is from gut to haemolymph, interestingly, retrograde transport of fusion

protein from haemolymph to gut can also occur, suggesting that transport across the gut is a passive, rather than an active process.

Whereas the P11a/GNA fusion protein shows effective oral toxicity in the Lepidopteran and Dipteran insects tested while its component proteins either have no toxicity, or very limited toxicity, the situation is less clear cut in aphids. The fusion protein was a more effective toxin than either of its components, or a mixture of its components, but both components of the fusion showed significant oral toxicity. For GNA, this is in agreement with previous reports of oral toxicity to aphids and other Hemipteran insects. The oral toxicity of the P11a toxin itself is more surprising, and the mechanism through which the toxin is able to access sites of action when fed to aphids remains obscure. Further experiments will be necessary to show whether the binding of toxin to the gut surface in aphids leads to transport to the haemolymph (as is the case for GNA) or whether the toxin remains in the gut contents. In this example, fusion to GNA enhances the oral toxicity of P11a rather than conferring novel oral toxicity.

The slug injection results demonstrate that the P11a/GNA fusion protein is toxic against *D. reticulatum*. This should be the first report of a spider toxin that is active against molluscs (this work was done by Dr. Fitches E in FERA). Moreover, the dead slugs killed by P11a/GNA fusion protein seem to be shrinking all the time and the volume is much smaller than that of control slugs. After 6 days bioassay, 60% mortality was observed after injection of 100 µg per slug of purified P11a/GNA fusion proteins (containing 41µg P11a toxin). In Tan's paper published in 2002, purified lipopolysaccharide (LPS) from the 3-day *Moraxella osloensis* (*M. osloensis*) cultures caused around 50% death at a dose of 48 µg per slug while 41µg P11a toxin per slug contained in the fusion protein caused 60% mortality of slug (Tan and Grewal, 2002). This suggests that the spider toxin P11a is a little more toxic than LPS. Therefore, the recombinant P11a/GNA fusion protein, as a novel type of toxin against slugs, has a broad prospect of application in the future.

The P11a toxin acts by binding to receptor site 4 in the sodium channel protein, which involves the extracellular loops of S1-S2, S3-S4 of domain II (Cestèle and Catterall, 2000). It affects the functional properties of the sodium channel "subunit"

by shifting the voltage dependence of activation, resulting in paralysis. P11a toxin is able to not only affect the insect ion channel, but also ion channel of molluscs. Furthermore, from the feeding results of P11a/GNA against bees, P11a toxin has been found to be safe for honeybees despite bees have internalized the fusion protein (this work was done by Mr. Erich Tempel Nakasu in Newcastle University). Although P11a/GNA was carried to the brain of the honeybee, it had no effect on the insect, which suggests the highly selective spider-venom toxin does not interact with the sodium channels in the bee.

Summary

The amaurobitoxin-lectin fusion protein described in this chapter is a promising candidate for development as a bio-pesticide with activity against Lepidopteran and Dipteran pests; it has an approx. 10-fold lower LD₅₀ towards *M. brassicae* larvae by injection than the Hv1a/GNA fusion protein described by Fitches et al. (2012), and caused mortality after droplet feeding a single dose to 5th instar larvae of *M. brassicae*, whereas a greater dose of Hv1a/GNA fusion protein only caused growth retardation. It is also approx. 8-fold more active towards *M. domestica* adults than the ButaIT/GNA scorpion toxin fusion protein described by Fitches et al. (2009), where a 1.0µg/µl solution caused only 75% mortality after 72h, in contrast to 70% mortality produced by a 0.125µg/µl solution of P11a/GNA. Even more important, inclusion of a synthetic N-terminal Pro-region in the P11a or P11a/GNA construct can lead to enhanced toxicity of P11a/GNA fusion protein, which reduces the LD₅₀ for the recombinant fusion protein P11a/GNA. Moreover, the P11a/GNA fusion protein is toxic against *D. reticulatum*, which caused 60% mortality at a dose of 100 µg per slug. Preferably, P11a/GNA caused no effect on honeybees. Therefore, further trials of insecticidal activity and selectivity will be necessary to ensure that the fusion protein could be used safely in agricultural applications.

CHAPTER 5 ADDITION OF NATIVE PRO-REGION TO OMEGA-ATRACOTOXIN (HV1A) IN A RECOMBINANT FUSION PROTEIN WITH GNA (PRO-HV1A/GNA) RESULTS IN SIGNIFICANTLY ENHANCED INSECTICIDAL ACTIVITY AS COMPARED TO HV1A/GNA

Introduction

A shortage of new available chemistries together with the relatively narrow range of molecular targets of approved pesticides has increased selection pressure resulting in an escalation in problems associated with resistance development. Over 600 species of insects and mites are now resistant to one or more classes of chemical insecticides (Bass and Field, 2011). The development of genetically modified insect resistant crops expressing the bacterially derived insecticidal protein *Bacillus thuringiensis* (Bt) has made a significant global impact over the past 20 years in reducing insecticide use, improving both target specificity and crop yield (Gatehouse et al., 2011). Nevertheless, there are growing concerns and evidence for the development of resistance to Bt with field-evolved resistance recently reported by Tabashnik et al., (2013) for 5 out of 13 major pest species evaluated. However, the success of GM Bt has fuelled research into the development of new bio-pesticides and the discovery of naturally derived pesticides which have potential for reduced environmental impact, improved target specificity and a wider spectrum of bioactivity. One such approach focuses on the exploitation of spider fusion proteins as a source of natural insecticidal compounds. The combination of carrier and toxin in a recombinant protein results in a fusion protein product with an oral toxicity not possessed by either component alone.

The present chapter reports the characteristics and biological activities of recombinant Pro-Hv1a and Pro-Hv1a/GNA (by addition of its native Pro-region). Based on existing literature, I hypothesised that inclusion of the native N-terminal Pro-region in the expression construct would be likely to result in better improved

folding of the toxin than inclusion of the synthetic N-terminal Pro-region (Chapter 4), when expressed in *P. pastoris*. The result in this chapter shows that the Pro-Hv1a fusion to GNA not only highly enhances the insecticidal activity of Hv1a, but also significantly enhances the toxicity of the fusion protein. Injection studies have been carried out with cabbage moth (*Mamestra brassicae*) larvae to compare the insecticidal activity of Pro-Hv1a and Hv1a, Pro-Hv1a/GNA and Hv1a/GNA. Feeding assays against *M. brassicae*, cereal aphid (*Sitobion avenae* F.) and pea aphid (*Acyrtosiphon pisum*) have also been conducted using Pro-Hv1a/GNA and Hv1a/GNA. All results demonstrated significantly increased toxicity of Pro-Hv1a/GNA as compared to P11a/GNA (Chapter 4), Hv1a/GNA and recombinant Pro-Hv1a. To my knowledge, this is the first example demonstrating that the incorporation of native Pro-region of an arachnid venom peptide and subsequent expression in yeast results in a significant enhancement of the biological activity of the recombinant toxin. This results presented suggest that the native N-terminal Pro-region plays an important role in the folding of recombinantly expressed cysteine rich venom peptides offering a promising way to enhance the toxicity of GNA-based insecticidal fusion proteins for crop protection in the future.

5.1 Characterizations of recombinant Hv1a, Pro-Hv1a and Pro-Hv1a/GNA

Purified recombinant Hv1a and Pro-Hv1a were separated using Tris-Tricine gel (15 % acrylamide) and analysed by western blot using anti-His antibodies (Fig. 5.1 A and B). In the Tris-Tricine gel, recombinant toxins Hv1a and Pro-Hv1a both gave a major protein band at approx. 14.4kDa, somewhat greater than the predicted masses of Hv1a (6.74 kDa) or Pro-Hv1a (8.87kD). The 14.4 kDa bands on the Tris-Tricine gels were also immunoreactive with anti-(His)₆ antibodies and may represent dimeric forms of Hv1a given that the predicted masses of Hv1a and Pro-Hv1a containing the C-terminal (His)₆ region but no Pro-region is 6.74 kDa (Fig. 5.1 B).

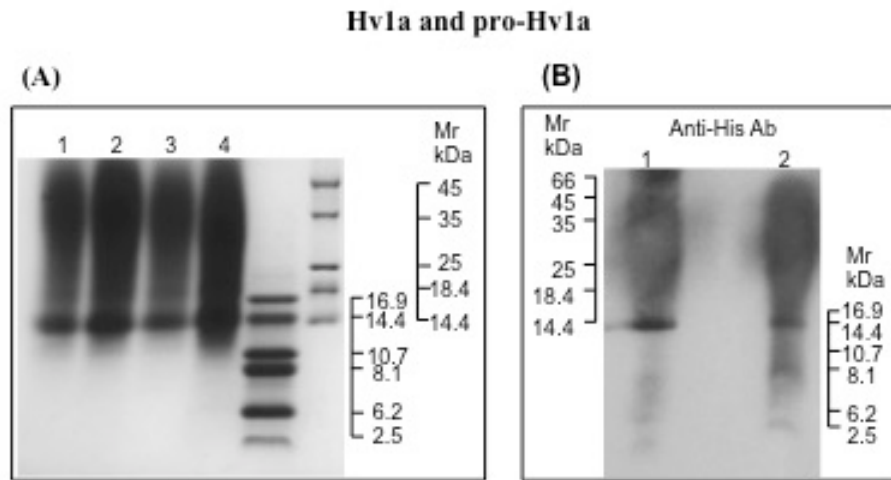

Figure 5.1

Characterisation of purified recombinant proteins Hv1a and Pro-Hv1a. (A) Tris-Tricine gel (15 % acrylamide) analysis showing purified recombinant Hv1a and Pro-Hv1a toxins from lyophilized powder. Lanes 1 and 2 are Hv1a toxin (37.5 and 75 µg, respectively) and lanes 3 and 4 are Pro-Hv1a toxin (37.5 and 75 µg, respectively) (B) Western blotting analysis of sample in Fig. 5.1 A using anti-His antibodies. Lane 1 is Hv1a toxin and lane 2 is Pro-Hv1a toxin. Marker is from Thermo Scientific Company.

Lyophilised samples of purified Hv1a/GNA and Pro-Hv1a/GNA were analysed on SDS-PAGE gels and by western blot (Fig. 5.2 A and B). Two bands of approx. 19 kDa and 14 kDa were observed for both fusion proteins. The predicted molecular mass for Hv1a/GNA is 16.13 kDa without a (His)₆ tag and 16.95 kDa with a (His)₆ tag, and for Pro-Hv1a/GNA without the Pro-region but containing a (His)₆ tag is also 16.95 kDa, both slightly less than the observed 19 kDa band. However, the identical separation of Pro-Hv1a/GNA and Hv1a/GNA on SDS-PAGE gels (same molecular weight) suggests that the Pro-region has been cleaved from Pro-Hv1a/GNA during processing by *Pichia* cells. Indeed N-terminal protein sequencing of Pro-Hv1a/GNA (N-terminal sequence SPTCI; see Fig. 5.3) confirmed cleavage of the Pro-region in the final product. In both cases the smaller 14 kDa band is immunoreactive with GNA antibodies and corresponds in size to GNA from which the Hv1a toxin has been cleaved (Fig. 5.2 B). As observed previously for Hv1a/GNA (Fitches et al., 2012), the ratio of intact Pro-Hv1a/GNA fusion protein to cleaved GNA was estimated as approx. 1:1 as judged by Coomassie blue staining on SDS-PAGE gels (Fig. 5.2 A). Quantification of Pro-Hv1a/GNA (Fig. 5.4 A) and Hv1a/GNA (Fig. 5.4 B) fusion proteins was based on comparative band intensity with GNA standards of known concentration.

Chapter 5 Addition of native Pro-region to omega-atracotoxin (Hv1a) in a recombinant fusion protein with GNA (Pro-Hv1a/GNA) results in significantly enhanced insecticidal activity as compared to Hv1a/GNA

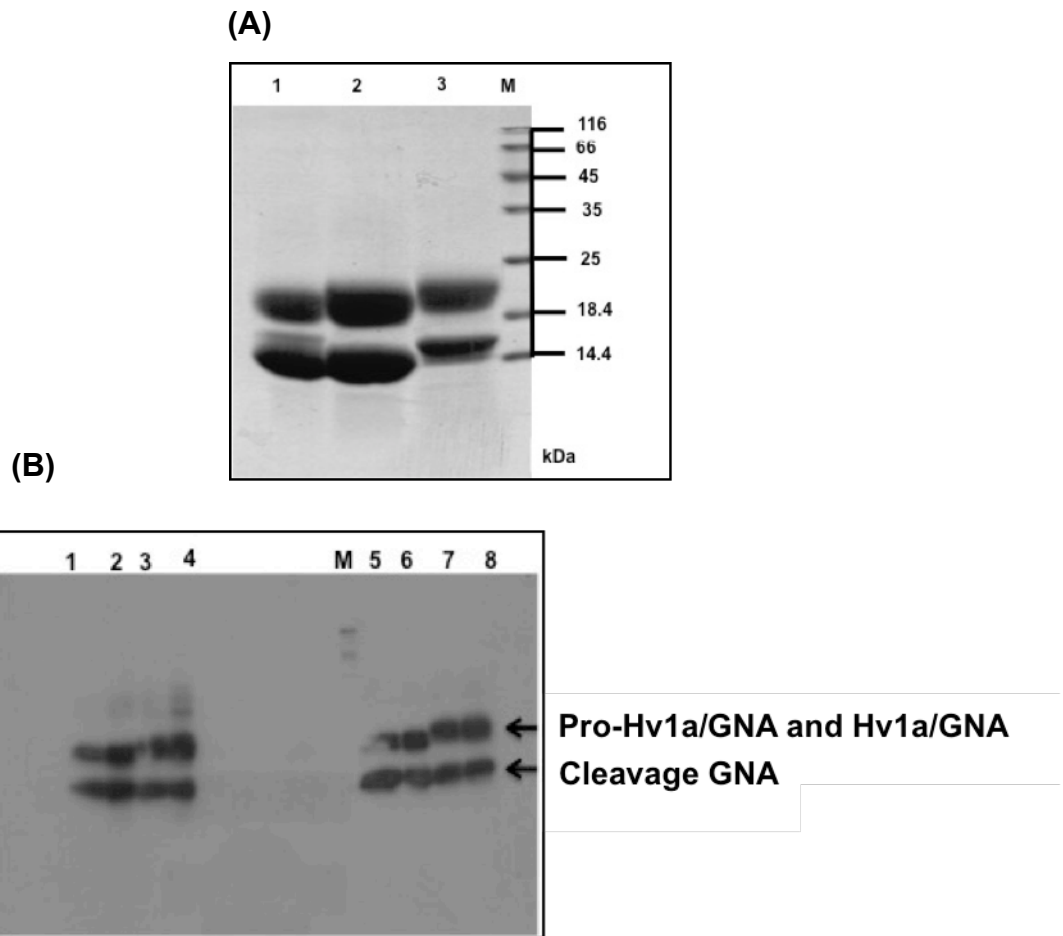

Figure 5.2

Characterisation of purified recombinant Hv1a/GNA and Pro-Hv1a/GNA fusion proteins. (A) SDS-gel analysis of recombinant Pro-Hv1a/GNA followed by Coomassie blue staining. Lane 1: Pro-Hv1a/GNA, lane 2: Hv1a/GNA; lane 3: MODHv1a/GNA (MODHv1a/GNA corresponds to the modified form of Hv1a/GNA, where a lysine; K was replaced by a glutamine (Q) at the C-terminus of Hv1a). Upper band is the fusion protein and lower band is cleaved GNA. (B) Western blotting analysis of Pro-Hv1a/GNA and Hv1a/GNA using anti-GNA (lane 1- lane 4) and anti-His (lane 5- lane 8) antibodies.

Chapter 5 Addition of native Pro-region to omega-atracotoxin (Hv1a) in a recombinant fusion protein with GNA (Pro-Hv1a/GNA) results in significantly enhanced insecticidal activity as compared to Hv1a/GNA

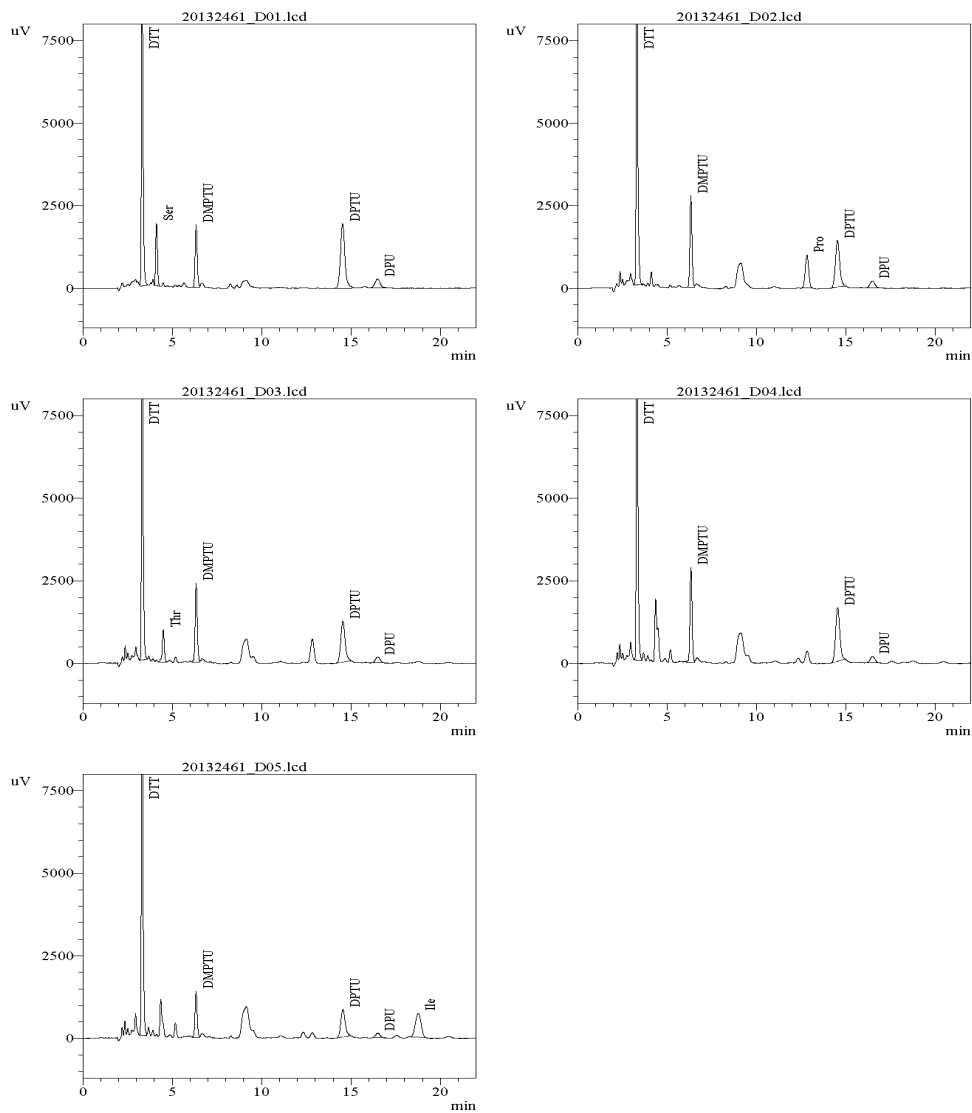
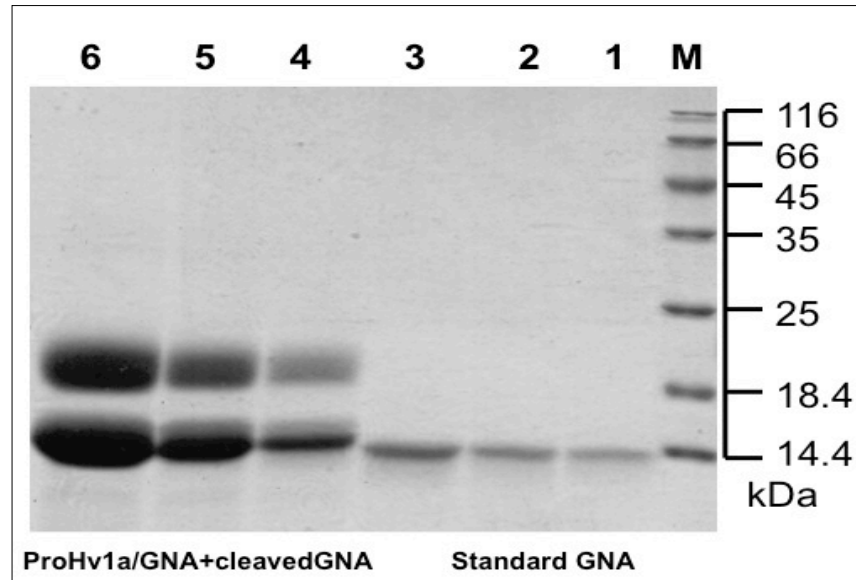

Figure 5.3

Pro-Hv1a/GNA fusion Protein N-terminal sequencing results. Five amino acids from N terminus are sequenced. Panel 1: Ser; panel 2: Pro; panel 3: Thr; panel 4: Cys; panel 5: Ile.

(A)



(B)

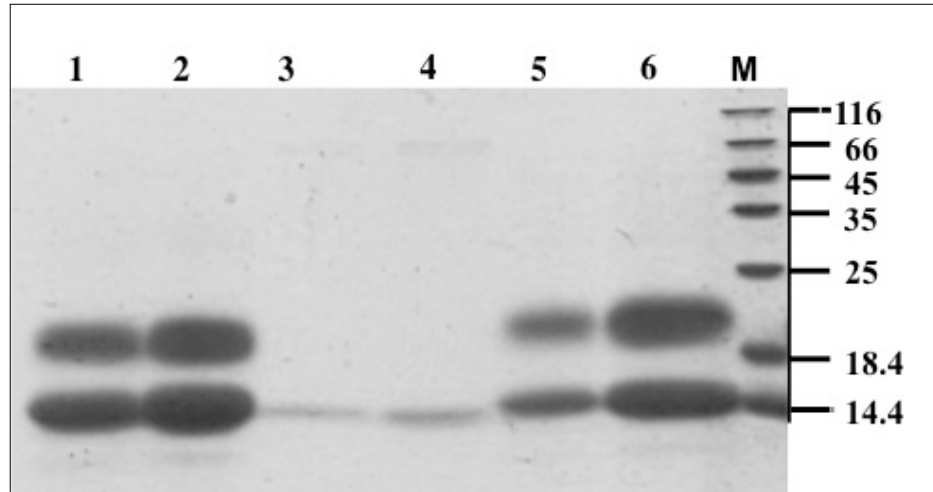

Figure 5.4

Quantification of purified recombinant Pro-Hv1a /GNA (A) and Hv1a/GNA (B) by 17.5% acrylamide SDS-PAGE gel. (A) Lanes 1-3 are loaded GNA standards of 1, 2, 4 µg. Lanes 4-6 are loaded 12.5, 25, 50 µg powder containing Pro-Hv1a/GNA, respectively. **(B)** Lanes 3-4 are GNA standards of 1, 2 µg. Lanes 1-2 are loaded 12.5, 25 µg powder containing Hv1a/GNA.

5.2 Injection bioassays of recombinant Hv1a and Pro-Hv1a toxins; Pro-Hv1a/GNA fusion protein to cabbage moth larvae

Injecting newly eclosed 3rd-4th (approx. 30-40mg) and 5th instar *M. brassicae* larvae (approx. 45-55 mg) with either Pro-Hv1a or Pro-Hv1a/GNA led to significant larval mortality. As shown in Fig. 5.5 A, the effect of recombinant Pro-Hv1a after injection into 5th instar larvae was dose dependent. Injection doses of 10µg-20µg Pro-Hv1a per insect resulted in complete mortality in 24 hours post injection. Insects displayed flaccid paralysis and a temporary absence of feeding. Mortality of 80% was still observed after 24h at a dose of 5µg toxin insect⁻¹. Moreover, injecting the lowest dose of 1.25µg insect⁻¹ recombinant Pro-Hv1a also resulted in significant approx. 80% mortality 72 hours post injection whereas injection of the highest dose of 20µg recombinant Hv1a only resulted in 10% mortality (p <0.0001). From these assays, the LD₅₀ (48h) for the recombinant Pro-Hv1a was calculated to be 25µg/g insect. In contrast, recombinant Hv1a showed little toxicity at injection doses of up to 40µg/g insect (only one death out of 10 larvae). Furthermore, the LD₅₀ value of 48 µg Hv1a/g insect on a molar basis insect calculated for Hv1a/GNA injection result (Fitches et al., 2012) is approx. 2-fold higher as compared to the LD₅₀ value for Pro-Hv1a (25µg/g insect).

As shown in Figures 5.5 B and C, injections of 5th and 3-4th instar *M. brassicae* larvae showed increased toxicity of Pro-Hv1a/GNA as compared to Hv1a/GNA. Significant data showed that injection dose of 10 µg insect⁻¹ of Hv1a/GNA into 5th instar larvae resulted in 25 % mortality 24h post injection while 100 % mortality was recorded at the same dose of Pro-Hv1a/GNA after 24h (p <0.0001) (Fig. 5.5 B). Insects displayed flaccid paralysis and a temporary or permanent absence of feeding. After 2-3 hours, the color of head and abdomen of *M. brassicae*, where the central nervous system is located, turned black. At the same time, the color of the whole body of *M. brassicae* became yellow with the whole body shrinking (Fig. 5.5 D). Significant larval mortality (75%) was observed at a Pro-Hv1a/GNA dose of 2.5 µg insect⁻¹ whereas injections of 5 µg insect⁻¹ of Hv1a/GNA did not result in any significant levels of mortality (5%) for 5th instar larvae (p <0.0001) (Fig. 5.5 B). Similar results of comparison of toxicities between Pro-Hv1a/GNA and Hv1a/GNA

Chapter 5 Addition of native Pro-region to omega-atracotoxin (Hv1a) in a recombinant fusion protein with GNA (Pro-Hv1a/GNA) results in significantly enhanced insecticidal activity as compared to Hv1a/GNA

were also observed following the injection of smaller 3-4th instar larvae (Fig. 5.5 C). LD₅₀ (48h) values estimated for Pro-Hv1a/GNA were approx. 20-fold lower (10µg/g insect) as compared to an LD₅₀ (72h) of 200µg /g insect for Hv1a/GNA. Moreover, the LD₅₀ value of 2.4 µg Hv1a/g insect calculated for Pro-Hv1a/GNA on a molar basis is some 10-fold lower than 25µg/g insect estimated for Pro-Hv1a (data summarized in Table 1). Injections of GNA alone at up to 40 µg insect⁻¹ do not result in mortality of *M. brassicae* larvae.

Chapter 5 Addition of native Pro-region to omega-atracotoxin (Hv1a) in a recombinant fusion protein with GNA (Pro-Hv1a/GNA) results in significantly enhanced insecticidal activity as compared to Hv1a/GNA

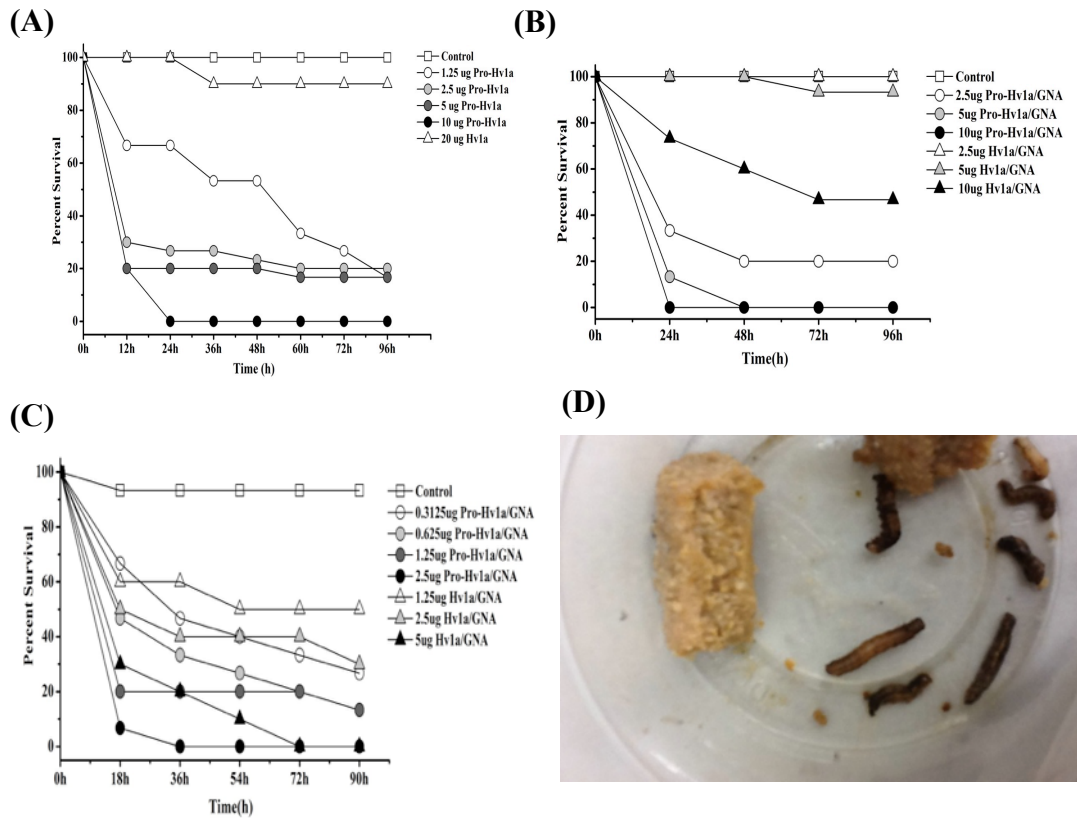

Figure 5.5

Survival recorded for newly enclosed 3rd-5th instar larvae of *M. brassicae* following the injection of different doses of recombinant Pro-Hv1a, Pro-Hv1a/GNA. (A) Injection of recombinant Pro-Hv1a to 5th instar larvae. (B) Injection of Pro-Hv1a/GNA to 5th instar larvae (Dose A for Pro-Hv1a/GNA and Dose B for Hv1a/GNA). (C) Injection of Pro-Hv1a/GNA to 3rd-4th instar larvae (Dose A for Pro-Hv1a/GNA and Dose B for Hv1a/GNA). (D) Phenotypic characteristic of *M. brassicae* after injection of Pro-Hv1a/GNA fusion protein (10 µg insect⁻¹).

Chapter 5 Addition of native Pro-region to omega-atracotoxin (Hv1a) in a recombinant fusion protein with GNA (Pro-Hv1a/GNA) results in significantly enhanced insecticidal activity as compared to Hv1a/GNA

Table 5.1

Toxicity of Recombinant Toxins and Fusion Proteins in Injection Bioassays with Lepidopteran (*Mamestra brassicae*) Larvae (Hv1a and Pro-Hv1a toxins; Hv1a/GNA and Pro-Hv1a/GNA fusion proteins).

Hv1a (literature)	Hv1a (<i>P. pastoris</i>)	Pro-Hv1a	Hv1a in Hv1a/GNA	Hv1a in Pro-Hv1a/GNA	Hv1a (<i>E.coli</i>)
1.0-12µg/g (<i>Heliothis</i> ; paralysis)	>1000µg/g	25µg/g ((48h)	48µg/g (72h)	2.4µg/g (48h)	69µg/g (72h)

Notes: Figures are for LD₅₀ of Hv1a component ar 48h or 72h, with *M. brassicae* larvae unless otherwise noted. The toxins and fusion proteins are from yeast fermentation except Hv1a (from yeast fermentation or *E.coli*). Per gram means per gram larvae.

5.3 Feeding bioassays of recombinant Hv1a/GNA and Pro-Hv1a/GNA to cabbage moth larvae

The oral activities of Pro-Hv1a/GNA and Hv1a/GNA were assessed by feeding 2 µl droplets containing 20 µg of fusion protein insect⁻¹ to newly enclosed third instar *M. brassicae* larvae. Control treatments were 20 µg of either GNA or Pro-Hv1a (on its own) insect⁻¹, in addition to a no-added protein control group. As shown in Fig. 5.6, significant effects were observed only for larvae fed on Pro-Hv1a/GNA, with 90% mortality recorded 5 days after the ingestion of a single droplet of fusion protein (p <0.0001). In contrast, mortality was only 30% for the Hv1a/GNA fusion protein, only slightly greater than the 20% and 15% mortality observed for GNA and Pro-Hv1a treatments, respectively (data summarized in Table 2). Significant results were also observed in assays where a single dose of 20µg of Pro-Hv1a/GNA fusion protein insect⁻¹ was found to cause 30% mortality of fifth instar larvae over 4 days, whereas no mortality was observed for larvae fed on either 20µg of Hv1a/GNA, or Pro-Hv1a insect⁻¹ (p <0.0001).

Chapter 5 Addition of native Pro-region to omega-atracotoxin (Hv1a) in a recombinant fusion protein with GNA (Pro-Hv1a/GNA) results in significantly enhanced insecticidal activity as compared to Hv1a/GNA

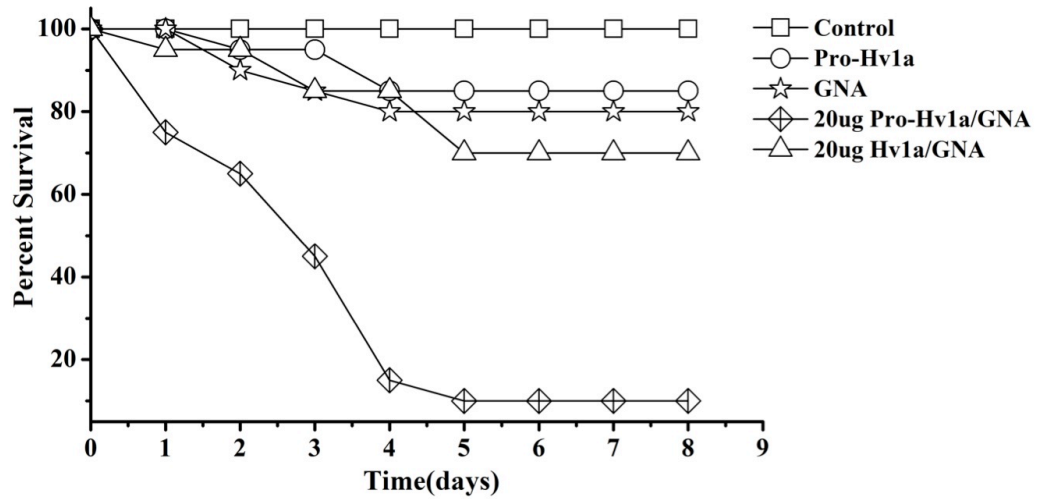

Figure 5.6

Survival of third instar larvae of *M. brassicae* following consumption of a single droplet containing recombinant protein. Control diet; diet containing GNA (2 μ l 10 μ g/ μ l); diet containing Pro-Hv1a (2 μ l 10 μ g/ μ l); diet containing Hv1a/GNA (2 μ l 10 μ g/ μ l) and diet containing Pro-Hv1a/GNA (2 μ l 10 μ g/ μ l); n = 10 per treatment.

Chapter 5 Addition of native Pro-region to omega-atracotoxin (Hv1a) in a recombinant fusion protein with GNA (Pro-Hv1a/GNA) results in significantly enhanced insecticidal activity as compared to Hv1a/GNA

Table 5.2

Toxicity of Recombinant Toxins and Fusion Proteins in Oral Feeding Bioassays with Lepidopteran Larvae (*Mamestra brassicae*). Abbreviations as in Table 5.1.

Hv1a (literature)	Hv1a (recombinant)	Pro-Hv1a	Hv1a/GNA	Pro-Hv1a/GNA	Hv1a (<i>E. coli</i>)
ND	ND	85% 5d 600µg/g	70% 5d 500µg/g	10% 5d 500µg/g	100% 5d 180µg/g

Notes: Figures are for survival % over 5 days; 3rd instar larvae (mean weight 40 mg) fed a single droplet giving the stated dose of fusion protein. Per gram means per gram larvae.

5.4 Detection of ingested Pro-Hv1a/GNA in the haemolymph of *M. brassicae* larvae by western blotting

To determine if Pro-Hv1a/GNA fusion protein was capable of getting from the gut to the hemolymph of *M. brassicae* larvae, haemolymph was extracted from insects fed on droplets containing Pro-Hv1a/GNA and analyzed for the presence of fusion protein by western blotting using anti-GNA antibodies. Insects were starved (generally 24h), given a single dose of Pro-Hv1a/GNA, 15µg insect⁻¹ in 2µl droplet and then returned to normal rearing diet for a "pulse-chase". The blot confirmed intact Pro-Hv1a/GNA fusion protein existed in samples from larvae fed on Pro-Hv1a/GNA after 2h by western blotting (Fig 5.7).

Chapter 5 Addition of native Pro-region to omega-atracotoxin (Hv1a) in a recombinant fusion protein with GNA (Pro-Hv1a/GNA) results in significantly enhanced insecticidal activity as compared to Hv1a/GNA

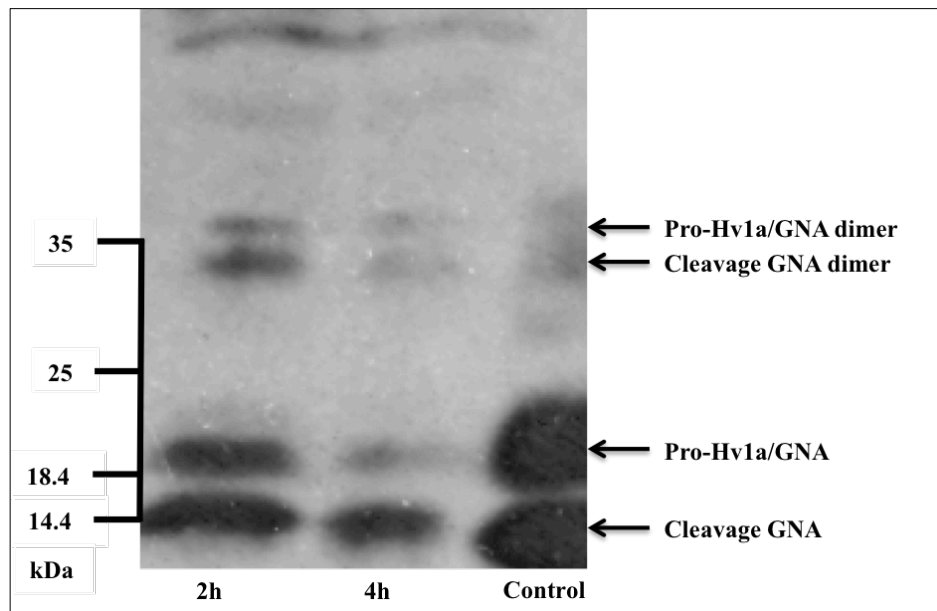

Figure 5.7

Transport of Pro-Hv1a/GNA fusion protein from gut contents to haemolymph in larvae of cabbage moth (*Mamestra brassicae*). Larvae were fed a single dose of Pro-Hv1a/GNA fusion protein, and haemolymph was sampled at the indicated time after feeding. The presence of Pro-Hv1a/GNA fusion protein was visualised by SDS-PAGE analysis of extracted proteins, followed by western blotting using anti-GNA antibodies. 500 ng purified Pro-Hv1a/GNA fusion protein was loaded as a positive control.

5.5 Ingestion toxicity of Pro-Hv1a/GNA fusion protein to pea aphids, cereal aphids and peach-potato aphids

Recombinant Pro-Hv1a protein, Pro-Hv1a/GNA and Hv1a/GNA were tested for oral activity against pea (*Acyrtosiphon pisum*), cereal (*Sitobion avenae* F.) and peach-potato (*Myzus persicae*) aphids by incorporation into artificial diet at concentrations of 0.125 mg – 0.75 mg/ml (125 - 750 ppm). In aphids, purified Pro-Hv1a/GNA was found to be significantly more toxic than Hv1a/GNA to these three aphid species (Fig. 5.8 A, B and C). Pro-Hv1a/GNA at 750 ppm caused 100% mortality of pea aphids after 3 days, whereas the same dose of Hv1a/GNA resulted in only 50% mortality after 8 days of feeding ($p < 0.0001$) (Fig. 5.8 A). At a lower dose of 500 ppm, mortality after 8 days of feeding was 100% for pea aphids fed on Pro-Hv1a/GNA as compared to 20% fed on Hv1a/GNA ($p < 0.0001$) (Fig. 5.8 A).

Pro-Hv1a/GNA was also found to be significantly more toxic than Hv1a/GNA to cereal aphids. As shown in Fig. 5.8 B, 100% mortality was recorded for cereal aphids fed on diets containing 250 ppm of Pro-Hv1a/GNA for 7 days as compared to 60% for Hv1a/GNA fed aphids ($p < 0.05$). Cereal aphids appear to be more susceptible to Pro-Hv1a/GNA than pea aphids as significant levels of mortality were observed at levels as low as 125 ppm Pro-Hv1a/GNA (80% mortality after 2 days of feeding) whereas no mortality was recorded for pea aphids fed on the same dose of fusion protein ($p < 0.0001$).

Furthermore, Pro-Hv1a/GNA was significantly more toxic than Hv1a/GNA to peach-potato aphids. As shown in Fig. 5.8 C, 90% mortality was recorded for peach-potato aphids fed on diets containing 500 ppm of Pro-Hv1a/GNA for 7 days. In contrast, only 40% mortality was recorded for aphids fed on the same dose of Hv1a/GNA ($p < 0.0001$). Peach-potato aphids seem to be a little more resistant to Pro-Hv1a/GNA than pea aphids and cereal aphids. Mortality were observed at levels as low as 250 ppm Pro-Hv1a/GNA (80% mortality 7 days post feeding) whereas the same dose of fusion protein caused 90% mortality of pea aphids after 7 days of feeding and 100% mortality of cereal aphids after 2 days of feeding ($p < 0.05$).

Chapter 5 Addition of native Pro-region to omega-atracotoxin (Hv1a) in a recombinant fusion protein with GNA (Pro-Hv1a/GNA) results in significantly enhanced insecticidal activity as compared to Hv1a/GNA

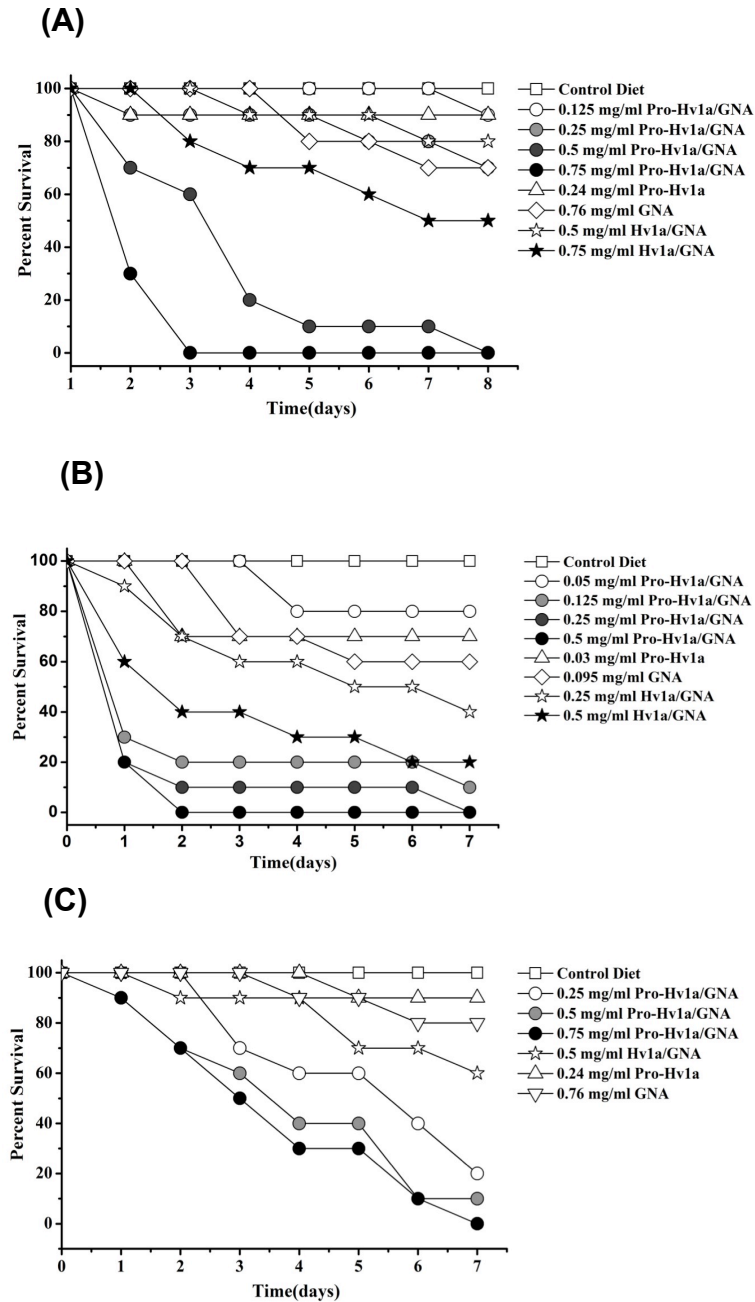

Figure 5.8

Survival recorded of pea (*A. pisum*) (A), cereal (*S. avenae*) (B) and peach potato (*M. persicae*) (C) aphids fed on artificial diets containing 0.05–0.75 mg/ml of purified recombinant Pro-Hv1a, Pro-Hv1a/GNA, Hv1a/GNA or GNA.

Discussion

Hv1a/GNA fusion protein, fusing Hv1a coding sequence to the N-terminus of a coding sequence corresponding to residues 1–105 of mature snowdrop lectin (GNA) via a 3 amino acid (AAA) linker peptide, was made by Fitches et al. (2012) using *P. pastoris* as an expression host. However, recombinant Hv1a did not show any biological activity / toxicity during yeast expression. Hv1a only has some toxicity when produced in *E. coli* being expressed as GST fusion proteins (Tedford et al., 2001; Maggio and King, 2002a, b). As reported by Fitches (2012), although Hv1a/GNA had some insecticidal effect on insect pest, some cleavage occurred during expression, suggesting less yield of Hv1a/GNA fusion protein in the yeast than that of other spider protein like P11a/GNA (Yang et al., 2014a).

Hv1a, as a component of Hv1a/GNA fusion protein, showed toxicity to insect pests, as it appears that linkage to GNA can assist folding of the Hv1a toxin (Fitches et al., 2012). Similarly, GNA also played a vital role in folding of P11a/GNA fusion protein, as the insecticidal activity of P11a/GNA is higher than that of P11a (Chapter 4). Nevertheless, the addition of the native Pro-region of Hv1a in the fusion protein Pro-Hv1a/GNA fusion protein resulted in a product that was significantly more insecticidal than Hv1a/GNA. This implies that a native Pro-region has much higher efficiency than GNA under process of protein folding. Therefore, for some cysteine-knot peptides that contain 3 or 4 disulfide bonds, both native and synthetic Pro-regions are necessary for correctly well-organized combination of disulfide bonds. These results are similar to those previously reported. For example, a single cysteine of the BPTI Pro-region strikingly increases the proportion of folding by serving as an intramolecular disulfide “agent” and promoting the formation of the proper disulfide bonds (Weissman and Kim, 1992; Pringos et al., 2011).

The injection data reported in this paper shows that recombinant Pro-Hv1a and Pro-Hv1a/GNA fusion proteins are all insecticidal against *M. brassicae* larvae with the anticipated symptoms of paralysis and mortality. The LD₅₀ value of Pro-Hv1a (25µg/g insect) is approx. 3–fold lower than LD₅₀ value of recombinant Hv1a toxin (69µg/g insect) produced in *E. coli* (mentioned by Gatehouse et al., in 2013). Moreover, the injection data also reported that the LD₅₀ value for Pro-Hv1a (25µg/g

insect) is approx. 2-fold lower than the LD₅₀ value of 48µg Hv1a/g insect on a molar basis calculated for Hv1a/GNA (Fitches et al., 2012). The LD₅₀ value for Pro-Hv1a is also approx.3-fold lower than the LD₅₀ value of recombinant P11a toxin (82µg/g insect) (Chapter 4). The above results demonstrate that native N-terminal Pro-region of Hv1a can not only improve the toxicity of Hv1a peptide, but also plays a vital role than GNA in the proper folding of Hv1a. From the injection data of Pro-Hv1a/GNA fusion protein, the expressed Pro-Hv1a/GNA fusion protein showed the most insecticidal effect of all the recombinant proteins including Pro-Hv1a and Hv1a/GNA; Ao1bPro-P11a, Ao1bPro-P11a/GNA and Hv1aPro-P11a/GNA (Chapter 4); Pro-Ec2a/GNA proteins (data in the Appendix 7) on *M. brassicae* larvae. The results suggest that incorporation of a native Pro-region is likely to produce more effective recombinant toxins and fusion proteins as compared to the incorporation of a synthetic Pro-region. However, further work to compare the toxicity of Pro-Hv1a with a construct incorporating a synthetic Pro-region is required to verify this hypothesis. In summary, without fusion to GNA, both native Pro-region and synthetic Pro-region are able to facilitate correct folding of peptides. However, when Pro-region/peptides are fused to GNA as fusion proteins, the native Pro-region can better facilitate the proper folding of peptides than the synthetic Pro-region. It is because when Kex2 protease from the yeast recognizes the Pro-region and starts to cleave it, the native Pro-region is better able to form more correct disulfide bridges to further lead to the correct spatial structure of its own peptide under assistance of GNA.

As compared to other references, the LD₅₀ for our recombinant Pro-Hv1a alone is 25µg/g insect, or 3.7 nmoles/g insect in the injection bioassays against *M. brassicae* larvae, which is approx. 1-fold higher than the quoted literature value for synthetic Hv1a against the cotton bollworm *Helicoverpa armigera*, the reported ED₅₀ of which is 3nmol/g (Atkinson et al., 1999). In addition, the PD₅₀ dose of synthetic Hv1a reported for the tobacco hornworm *Heliothis virescens* is 0.25nmol/g, which is approx. 6-fold lower than the LD₅₀ of our recombined toxin Pro-Hv1a (Bloomquist, 2003). Therefore, different insecticidal results of Hv1a towards different species may be determined by different types of calcium ion channels

among different species or by the structural differences among native Hv1a, synthetic Hv1a and recombinant Hv1a (Fitches et al., 2012). As the LD₅₀ for recombinant fusion protein, Pro-Hv1a/GNA is 0.14nmol/g (2.4 µg/g insect) on a molar basis, 1.8-fold lower than the PD₅₀ (0.25nmol/g) of synthetic Hv1a against the cotton bollworm *Heliothis armigera*, which means Hv1a (addition of its own Pro-region), when fused to GNA (Pro-Hv1a/GNA), is able to reach expected highest biological activity, whereas the recombinant toxins of Hv1a, Pro-Hv1a or Hv1a/GNA alone does not. The Pro-Hv1a/GNA fusion protein is more toxic than P11a/GNA, Ao1bPro-P11a/GNA, Hv1aPro-P11a/GNA and Pro-Ec2a/GNA fusion proteins to Lepidopteran *M. brassicae* larvae. The LD₅₀ (48 h) for Pro-Hv1a/GNA was 4.8-fold lower than the LD₅₀ (48 h) for P11a/GNA (11.4 µg/g insect); 3.3-fold lower than that for Ao1bPro-P11a/GNA; 3.1-fold lower than that for Hv1aPro-P11a/GNA (Chapter 4) and 5.7-fold lower than that for Pro-Ec2a/GNA (13.7µg/g insect) (data in the appendix 7). However, without addition of the Pro-region to the Hv1a/GNA construct, the LD₅₀ (48 h) for Hv1a/GNA fusion protein was approx. 4-fold higher than the LD₅₀ (48 h) for P11a/GNA (Yang et al., 2014a). Pro-Hv1a/GNA fusion protein can also cause immediate damage (with effects visible after 2-3 hours) to the central nervous system of *M. brassicae*, which means that insect calcium ion channels are quite sensitive to Pro-Hv1a/GNA fusion protein. Nowadays, although most insect pests especially aphids, associated with mutations in the sodium channel, have developed resistance to pyrethroids and spider toxins targeting on sodium ion channels (Yang et al, 2014b). Low concentration of Pro-Hv1a/GNA fusion protein can still lead to damage to these mutated insect pest because mutations in the sodium channels cannot affect the insecticidal activity of toxin proteins targeting insect calcium channels. Therefore, the Pro-Hv1a/GNA fusion protein is suitable for being used in the management of insecticide-resistant insect strains, leading to its commercial use as a bio-pesticide (Eleftherianos et al., 2008; Yang et al, 2014b).

Hv1a seems to be orally active against the Lepidopteran insects *Spodoptera littoralis* and *Helicoverpa armigera* when it is expressed in plants (Khan et al., 2006) and it has been proved to be orally active against ticks (Mukherjee et al., 2006). Nevertheless, recombinant Hv1a or Pro-Hv1a alone in our experiment was not orally

active when fed to *M. brassicae* larvae due to no delivery system such as GNA to direct them to the central nervous system. In contrast, clear evidence was provided that Pro-Hv1a/GNA and Hv1a/GNA fusion proteins were orally toxic towards *M. brassicae* larvae in droplet feeding assays. The western blotting experiments also show transport of intact Pro-Hv1a/GNA fusion protein into the haemolymph after 2 or 24 hours, the result of which is similar to that previously reported for Hv1a/GNA by Fitches et al., (2012).

The Pro-Hv1a/GNA fusion protein also showed more effective oral toxicity than either of its components Pro-Hv1a and GNA, or Hv1a/GNA when fed to pea aphid *A. pisum*, cereal aphid *S. avenae* (F.) and peach-potato aphids *M. persicae*. GNA seems to have a little oral toxicity to aphids, which is certified by previous reports (Rahbé et al., 1995, Yang et al., 2014a, b). Recombinant Pro-Hv1a toxin also shows limited toxicity to aphids. It may also go across the gut and reach the haemolymph of aphids to disturb the function of the calcium ion channel although the mechanism remains less clear. As compared to the toxicity of 2mg/ml SFI1/GNA fusion protein against *M. persicae*, which could only lead to 32% mortality by day 7 (Down et al., 2006), Pro-Hv1a/GNA fusion protein appears to have much higher insecticidal activity against insect from Hemiptera: Aphididae. Pro-Hv1a/GNA at a concentration of 0.25 mg/ml resulted in 90% mortality of *A. pisum*, 100% mortality of *S. avenae* (F.) and 80% mortality of *M. persicae*, respectively. Moreover, 1.0 mg/ml and 0.5 mg/ml of recombinant HFR-1, a lectin-like protein derived from wheat, showed 100% mortality after 5 and 7 days exposure, respectively (Pyati et al., 2012). In contrast, Pro-Hv1a/GNA fusion protein at a much lower concentration of 0.125mg/ml is able to achieve the same effect.

From the analysis of the slug injecting results (this work was done by Dr. Fitches E in FERA.), Pro-Hv1a/GNA led to 100 % mortality on the third day after injection of 50 µg per slug of Pro-Hv1a/GNA (containing 23 µg Hv1a on a molar base), while a dose of 100 µg of MODHv1a/GNA just caused 20% death on the third day. This also implies that addition of Pro-region in a construct could significantly enhance the toxicity of protein after yeast expression (Bruce et al., 2011). Pro-Hv1a/GNA is also more toxic to slugs as compared to P11a/GNA, which cause 40%

mortality on the third day after injection of 100 µg per slug of purified P11a/GNA fusion proteins (containing 41ug P11a toxin). Pro-Hv1a/GNA, which targets on calcium ion channel of insect pest, is more effective than P11a/GNA, which targets on sodium ion channel if it is assumed that both Pro-Hv1a/GNA and P11a/GNA correctly folded. Furthermore, Pro-Hv1a/GNA could also be used as a molluscicide bait, which mixes a mollusc attractant with toxins so as to encourage exposure of slugs to the molluscicide (Bailey, 2002). This method could be extremely effective against slugs.

Summary

The data above provides further evidence that the function of native N-terminal Pro-region is necessary in improving the proper folding of peptides. Even more important, the Pro-Hv1a/GNA fusion protein described in this paper has no detrimental impact on honeybees, indicating that atracotoxins could be potential alternatives to conventional pesticides (Nakasu et al., 2014). Therefore, the Pro-Hv1a/GNA fusion protein, as a bio-pesticide targeting calcium ion channels, is a highly promising candidate for development with high activity against Lepidopteran and Hemipteran pests or other pest species of different orders in agricultural applications.

CHAPTER 6 EFFECT OF INSECTICIDAL FUSION PROTEINS CONTAINING SPIDER TOXINS TARGETING SODIUM AND CALCIUM ION CHANNELS ON PYRETHROID-RESISTANT STRAINS OF PEACH-POTATO APHID (*MYZUS PERSICAE*)

Introduction

The peach-potato aphid, *Myzus persicae* (Sulzer) (Hemiptera: Aphididae), is a serious worldwide insect pest of agricultural and horticultural crops, which, through its sap-sucking feeding habit, can transmit viral diseases (Eleftherianos et al., 2008). Pyrethroids are a major class of insecticides used to control this pest, but strains of *M. persicae* can rapidly develop resistance to pyrethroids, leading to increased economic loss to agricultural producers (McCaffery and Nauen, 2006). Pyrethroids target the insect voltage-gated sodium channel, a large trans-membrane protein composed of a single 260kDa polypeptide (the alpha subunit), which contains four repeating and homologous domains (I–IV), with each domain being constituted by six hydrophobic transmembrane segments (S1–S6) (Catterall, 2000). The insect sodium channel is similar in structure to the vertebrate sodium channel, containing different allosterically coupled receptor-binding sites for various neurotoxicants, but the two types of channel are distinguishable in the pharmacology. The size and the function domain between insect sodium channel and vertebrate sodium channel are totally different. Some medicines for human diseases, which target on human sodium ion channel, do not have any effects on insect pests (Tan et al., 2002). Therefore insecticides such as pyrethroids can be specific for insect sodium channels, showing no effect on mammals (Vassilevski et al., 2009; Zlotkin, 1999).

Pyrethroids are hydrophobic compounds and are thought to bind to the lipid-exposed interface formed by helices IIS6, IIS5, linker helix IIS4-IIS5 and the IS4-IS5 linker (Du et al., 2009, 2013), affecting the functional properties of the sodium channel. By preventing closure of the sodium channel, pyrethroids cause paralysis in

insects (Zlotkin, 1999). However, with the extensive use of pyrethroids, many insects have developed resistance to these insecticides, associated with mutations in the sodium channel. The pyrethroid resistance shown by *M. persicae* is typical of that seen in many species (Williamson et al., 1996; Martinez - Torres et al., 1998; Kranthi et al., 2002). In aphids carrying the *kdr* mutation, there is a leucine to phenylalanine substitution (L1014F) within segment 6 of domain II (IIS6) of the channel protein (Miyazaki et al., 1996), which confers an intermediate level of resistance to pyrethroids (Fig 6.1). In aphids carrying the *super-kdr* site mutation, there is an additional methionine- to-threonine substitution (M918T) in the linker between segment 4 and segment 5 of domain II (IIS4-IIS5 linker) of the sodium channel protein (Williamson et al., 1996), which makes *M. persicae* highly resistant to pyrethroids (Fig 6.1). Data presented by Eleftherianos et al. shows that whereas the EC_{50} for a typical pyrethroid insecticide on wild-type *M. persicae* is in the range 0.5 - 2.8 ppm, a homozygous *kdr* mutation increases the EC_{50} by 20-75 fold, and a heterozygous *kdr+super-kdr* mutation increases resistance by 100-500 fold (Eleftherianos et al., 2008). The emergence of insecticide resistance is one factor driving a need for new specific environmentally benign pesticides, which could be used in strategies to manage resistance to chemicals like pyrethroids more effectively.

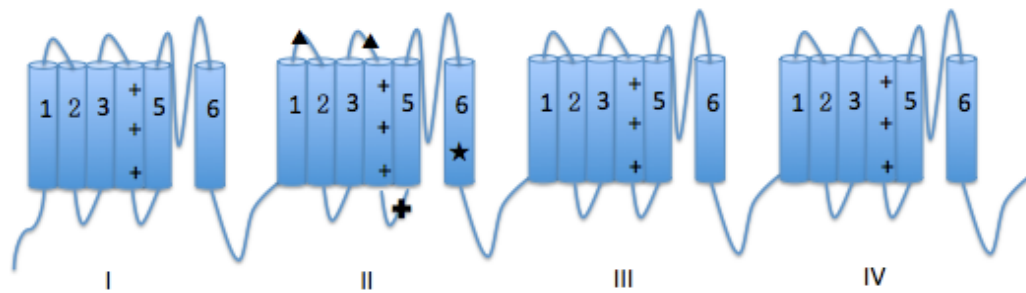

Figure 6.1

Diagram of the *M. persicae* voltage-gated sodium channel showing the four main repeating homologous domains (I–IV). The proposed membrane folding of the trans-membrane segments (S1–S6) within each domain and the locations of the two pyrethroid resistance-associated mutations (L1014F and M918L or M918T), (★) kdr and (+) super-kdr, identified in clones 794J and 4824J (Eleftherianos et al., 2008). (▲) stands for the receptor site 4 of sodium channel.

The present chapter compares the toxicity of P11a/GNA and Pro-Hv1a/GNA fusion proteins towards wild-type and pyrethroid-resistant strains of *M. persicae*, and shows that although the toxicity of P11a/GNA is reduced by the *kdr* and *super-kdr* mutations in the sodium channel, it retains some activity. However, the mutations confer no resistance to Pro-Pro-Hv1a/GNA targeting calcium channels. This residual high insecticidal activity makes Pro-Hv1a/GNA a potential bio-pesticide for controlling pyrethroid-resistant aphids.

6.1 Toxicity of separate components of fusion proteins

Effects of toxins and GNA components of insecticidal fusion proteins on the strains of peach-potato aphids (794J, UKO, 4824J and 4106A) were determined by bioassays in which components were fed separately in liquid diet from neonate nymphs. Concentrations were chosen to be equivalent to 1 mg/ml fusion protein. Results are shown in Fig. 6.2 A. None of the treatments caused more than 30% mortality over a 7-day period of development against a background of no mortality in aphids on control diet; survival analysis showed that most differences to control were not significant (effect on survival by difference in survival curve; $p > 0.05$). The GNA carrier protein showed significant effects on *M. persicae* survival (difference in survival curve; $p < 0.05$), in agreement with previous reports that this protein is weakly insecticidal towards aphids (Down et al., 2006). It also caused growth retardation at the beginning in the bioassays, although aphids were able to recover from the effects and produced nymphs (data not shown). There were no significant differences in the effects of GNA between aphid strains. At the concentrations used, the Pro-Hv1a toxin showed significant effects on *M. persicae* (30% mortality after 7 days; effect on survival by difference in survival curve $p < 0.05$), whereas P11a did not have a significant effect, although both toxins have been shown previously to have some effect on aphids when fed in diet. Once again, no significant differences between aphid strains were observed in these assays. These data confirm previous observations that the separate components of insecticidal fusion proteins have only limited insecticidal effects when fed to *M. persicae*.

Chapter 6 Effect of insecticidal fusion proteins containing spider toxins targeting sodium and calcium ion channels on pyrethroid-resistant strains of peach-potato aphid (*Myzus persicae*)

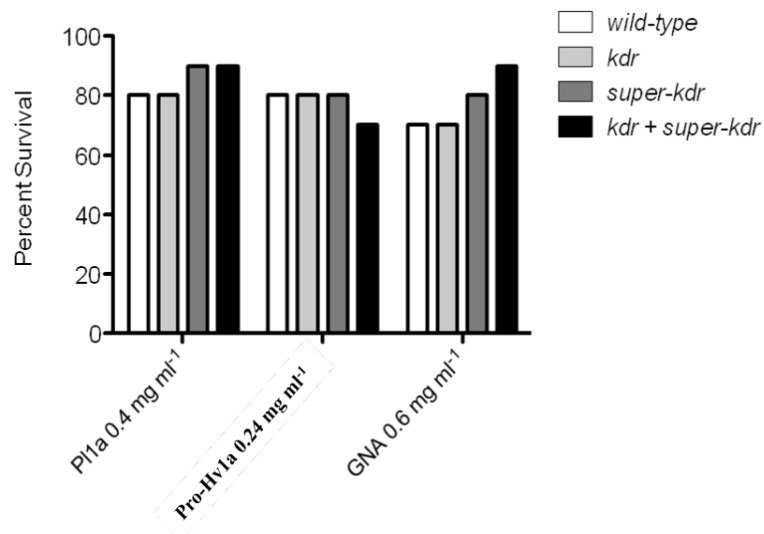

Figure 6.2

Toxicity of fusion protein components towards *M. persicae*. Graph shows survival after 7 days of pyrethroid-tolerant *M. persicae* strains (794J, kdr; UKO, super-kdr; and 4824J, kdr+super-kdr) and wild type 4106A strain after feeding artificial diet containing 0.4 mg ml⁻¹ Pl1a, 0.46 mg ml⁻¹ Pro-Hv1a or 0.6 mg ml⁻¹ GNA. Control survival was 100% over this interval (data not shown). n = 20 aphids per replicate.

6.2 Toxicity of P11a/GNA recombinant fusion protein

Purified recombinant P11a/GNA fusion protein was fed to each *M. persicae* strain at a range of concentrations, and survival curves were plotted for all treatments. Results for feeding at 1 mg ml⁻¹ are shown in Fig. 6.3 A. At this level, the fusion protein caused complete mortality to strain 4106A (*wild-type*) after 7 days, but not in any of the insecticide resistant strains, even after 11 days. The survival curves show significant differences between strains 4106A (*wild-type*), 794J (*kdr*) and UKO (*super-kdr*) and the controls not fed fusion protein (90% survival) ($p < 0.05$), confirming the insecticidal activity of the treatment. However, the survival curve for strain 4824J (*kdr + super-kdr*, 90% survival over the assay) fed P11a/GNA at 1 mg ml⁻¹ is not significantly different to that for aphids fed on control diet containing no fusion protein ($p < 0.05$). Survival curves for strains 794J (*kdr*) and UKO (*super-kdr*), which both show 40% survival over the assay, differ significantly from controls, from wild-type survival, and from strain 4824J survival ($p < 0.05$). Growth retardation was observed in all aphids exposed to fusion proteins, but was least in strain 4824J (Fig. 6.3 B), where aphids were able to produce nymphs during the assay period, as did the controls. No other aphid strain exposed to treatment was able to produce nymphs. The data demonstrate a differential effect of the fusion protein on the different aphid strains, with *wild-type* fully susceptible to the toxin at this concentration, whereas the *kdr* and *super-kdr* strains are partially tolerant, and the *kdr + super-kdr* strain is almost completely tolerant.

By analysing survival curves for aphids exposed to different concentrations of P11a/GNA, LC₅₀ values for the different strains could be deduced. The values obtained range from 0.35 to 1.76 mg ml⁻¹, and are shown in Table 6.1. There is a strong correlation between insecticide resistance of aphid strains and the LC₅₀ values; wild-type susceptible aphids have the lowest LC₅₀, and the order of insecticide tolerance (*wild-type* < *kdr* < *super-kdr* < *kdr + super-kdr*) is reflected in the LC₅₀ values (*wild-type* < *kdr* < *super-kdr* < *kdr + super-kdr*). The *kdr + super-kdr* strain 4824J has an LC₅₀ of 1.76 mg ml⁻¹ for P11a/GNA; recombinant protein at 2.0 mg ml⁻¹ caused significant effects on survival, and treatment with 2.5 or 3.0 mg ml⁻¹ of P11a/GNA resulted in complete mortality (Fig. 6.3 C).

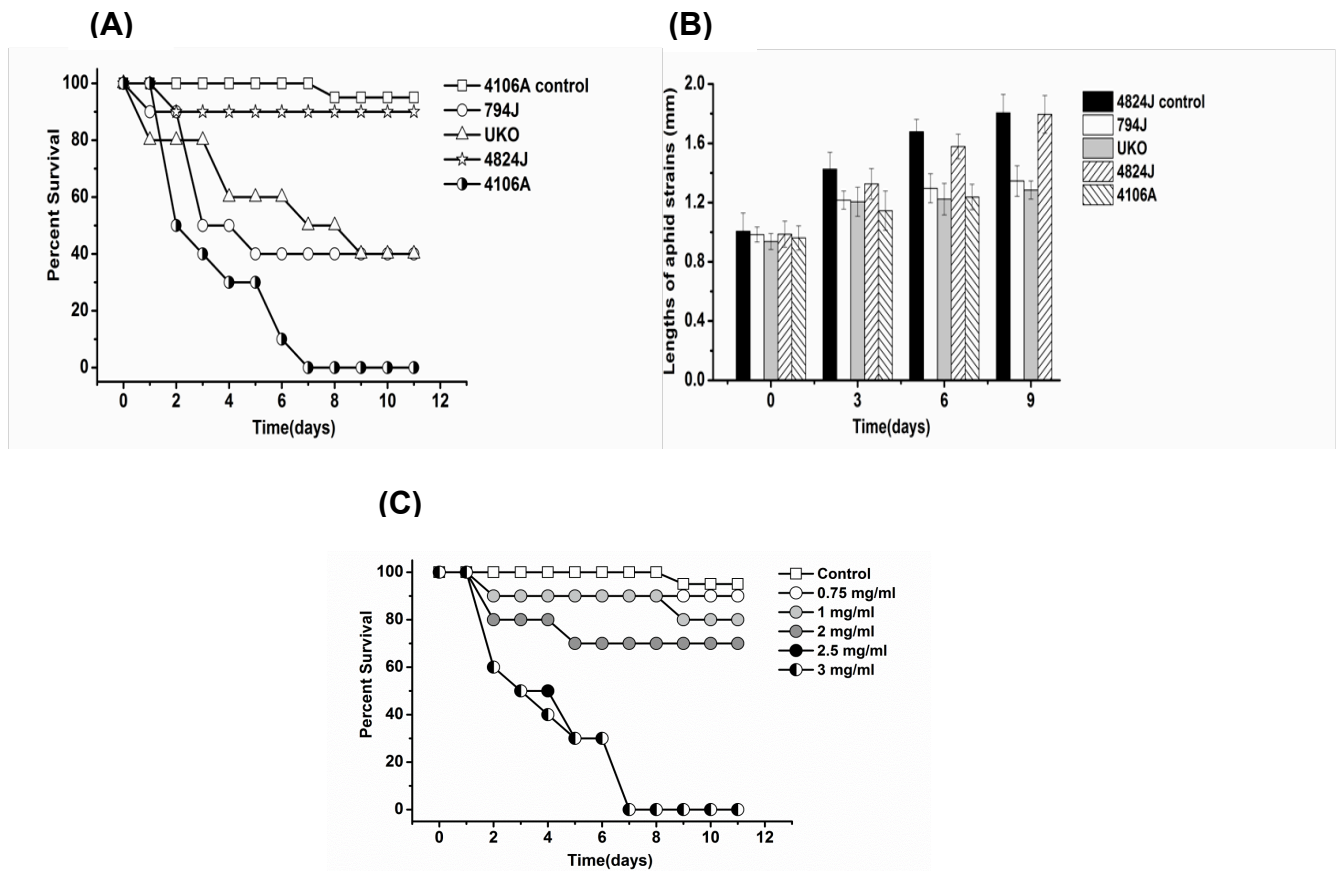

Figure 6.3

Survival data of P11a/GNA fusion protein towards *M. persicae*. (A) Toxicity of P11a/GNA fusion protein towards *M. persicae*. Graph shows survival curves of pyrethroid- tolerant *M. persicae* strains (794J, *kdr*; UKO, *super-kdr*; and 4824J, *kdr+super-kdr*), and wild type 4106A strain fed P11a/GNA at 1 mg ml⁻¹. All aphid strains on control diet showed survival similar to that presented for 4106A strain. n=20 aphids per replicate. (B) Growth suppression by P11a/GNA fusion protein. Graph shows lengths of aphid strains 794J, *kdr*; UKO, *super-kdr*; and 4824J, *kdr+super-kdr* and 4106A (wild type) from neonate to adult (9 days) after feeding on artificial diet containing 1 mg ml⁻¹ P11a/GNA (n=3 per treatment). 100 % mortality for strain 4106A prevented analysis for day 9. Data for strain 4824J fed on control diet is shown, but all aphid strains fed on control diet were of comparable size at each time point. (C) Dose-response effects of P11a/GNA. Graph shows survival curves of 4824J (*kdr+super-kdr*) *M. persicae* strain fed diets containing different concentrations of P11a/GNA in the range 0 - 3.0 mg ml⁻¹. n=20 aphids per replicate.

Chapter 6 Effect of insecticidal fusion proteins containing spider toxins targeting sodium and calcium ion channels on pyrethroid-resistant strains of peach-potato aphid (*Myzus persicae*)

Table 6.1

LC₅₀ (9 days) for fusion proteins against *M. persicae* strains.

Genotype (Strain)	LC ₅₀ (mg/ml) P11a/GNA	LC ₅₀ (mg/ml) Pro-Hv1a/GNA
<i>Wild type</i> (4106A)	0.35	0.19
<i>kdr</i> (794J)	0.60	0.28
<i>super-kdr</i> (UKO)	0.83	0.25
<i>kdr</i> + <i>super-kdr</i> (4824J)	1.76	0.20

6.3 Toxicity of Pro-Hv1a/GNA recombinant fusion protein

An insecticidal fusion protein containing the calcium-channel specific toxin Pro-Hv1a was used as a control to identify non-specific effects on sensitivity towards insecticidal compounds in the pyrethroid-resistant *M. persicae* strains. Purified recombinant Pro-Hv1a/GNA fusion protein was fed to each strain at a range of concentrations, and survival curves were plotted for all treatments. Results for feeding at 1 mg ml⁻¹ are shown in Fig. 6.4 A. Pro-Hv1a/GNA fusion protein at this concentration caused complete mortality to strains 4106A (*wild-type*) and UKO (*super-kdr*) after 6 days, and to strains 794J (*kdr*) and 4824J (*kdr + super-kdr*) after 9 days. The survival curves show significant differences between all strains fed fusion protein and the controls not fed fusion protein (100% survival over 11 days) ($p < 0.05$), in agreement with previous assays showing that this fusion protein is insecticidal. Growth retardation was apparent in all aphids exposed to fusion proteins (Fig. 6.4 B), and no aphids exposed to treatment were able to produce nymphs. Comparison of individual survival curves when Pro-Hv1a/GNA was fed at 1 mg ml⁻¹ suggested that strain 4824J (*kdr + super-kdr*) was more tolerant to Pro-Hv1a/GNA than *wild-type* aphids (strain 4106A), but that other differences were not significant. Assays at other concentrations of Pro-Hv1a/GNA did not give consistently significant differences between treatments, although a consistent trend towards greater susceptibility of the *wild-type* strain was observed.

LC₅₀ values for Pro-Hv1a/GNA in the different aphid strains were deduced by analysis of survival curves for aphids exposed to different concentrations fusion protein. The values obtained range from 0.19 to 0.28 mg ml⁻¹, and are shown in Table 6. 1. The LC₅₀ values show no significant differences between any of aphid strains although the *wild-type* strain, 4106A, has a lowest LC₅₀ value (Fig. 6.4 C and D). The uncertainties in LC₅₀ values are relatively large compared to the differences, but the fitted dose-response curve for the *wild-type* strain differs significantly from the other curves ($p < 0.05$), supporting the conclusion that this strain is more susceptible to Pro-Hv1a/GNA.

Chapter 6 Effect of insecticidal fusion proteins containing spider toxins targeting sodium and calcium ion channels on pyrethroid-resistant strains of peach-potato aphid (*Myzus persicae*)

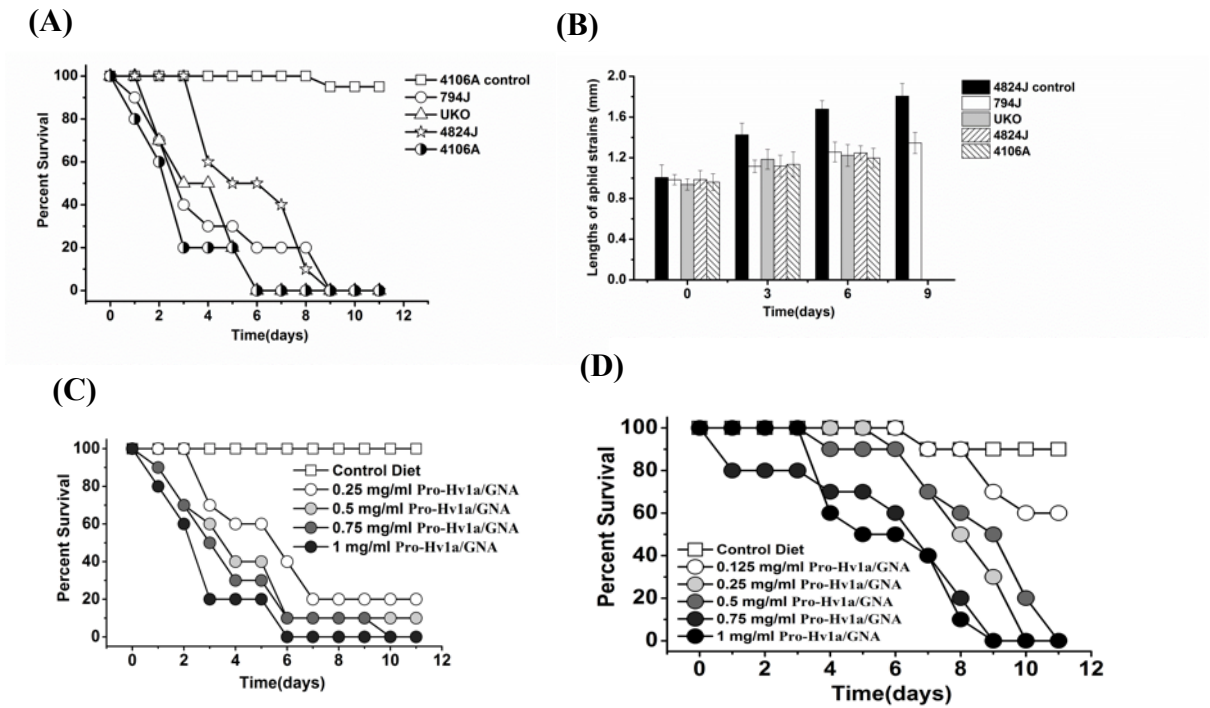

Figure 6.4

Survival data of Pro-Hv1a/GNA fusion protein towards *M. persicae*. (A)

Toxicity of Pro-Hv1a/GNA at 1 mg ml⁻¹ fusion protein towards *M. persicae*. n=20 aphids per replicate. (B) Growth suppression by Pro-Hv1a /GNA fusion protein. Graph shows lengths of aphid strains 794J, *kdr*; UKO, *super-kdr*; and 4824J, *kdr+super-kdr* and 4106A (*wild type*) from neonate to adult (9 days) after feeding on artificial diet containing 1 mg ml⁻¹ Pro-Hv1a /GNA (n=3 per treatment). 100 % mortality for strains UKO, 482J and 4106A prevented analysis for day 9. Data for strain 4824J fed on control diet is shown, but all aphid strains fed on control diet were of comparable size at each time point. (C) Dose-response effects of Pro-Hv1a /GNA. Graph shows survival curves of 4106A (*wild type*) *M. persicae* strain fed diets containing different concentrations of Pro-Hv1a /GNA in the range 0.25-1 mg ml⁻¹. n=20 aphids per replicate. (D) Dose-response effects of Pro-Hv1a /GNA. Graph shows survival curves of 4824J (*kdr+super-kdr*) *M. persicae* strain fed diets containing different concentrations of Pro-Hv1a /GNA in the range 0.125-1 mg ml⁻¹. n=20 aphids per replicate.

4. Discussion

The insect sodium channel is a major target for conventional pesticides, such as pyrethroids. The P11a toxin, which acts on the same target, could represent a novel type of insecticidal component as a substitute to pyrethroids. The mode of binding of this toxin would be expected to differ significantly from binding a small molecule channel blocker like a pyrethroid, with contacts between the toxin and the channel potentially extending over a wider area. However, P11a/GNA fusion protein exhibits reduced toxicity towards pyrethroid-resistant peach-potato aphid (*Myzus persicae*) strains, showing that the mutations, which remove sensitivity to pyrethroids also affect the binding of P11a. The mutations, which give pyrethroid sensitivity, are in domain II of the sodium channel, with the L1014 mutation in helix S6 and the mutation at M918 in the linker between helices S4-S5. Changes to the spatial structure of domain II as a result of these mutations presumably also disturb the binding of P11a to receptor site 4, in domain II. However, although the bioassays show that mutations in domain II of the insect sodium channel affect the insecticidal activity of the P11a/GNA fusion protein, some toxicity is still observed, with a higher concentration of fusion protein required to cause mortality in the pyrethroid-resistant *kdr* and *super-kdr* strains. This result implies that either some interactions still exist between P11a and domain IIS6 or domain IIS4-S5 linker of the mutated sodium channel, or that P11a also binds to other sites on the sodium channel to cause inactivation. However, it is not possible that P11a can bind to other ion channels except for the sodium ion channel. Firstly, if P11a toxin is able to bind to other ion channels, the pyrethroid-resistant *kdr* and *super-kdr* strains should be killed quickly as P11a would bind to other normal ion channels easily rather than bind to a mutated sodium channel. Secondly, from the sequences of P11a, it only recognizes insect voltage-gated sodium channels by multiple sequence features, including a β -sheet secondary structure, loops I, IV of the toxin and the specific dipolar moment orientation (Ferrat et al., 2005; Chapter 3). The extracellular loops of IIS1-S2, IIS3-S4 are thought to be the main binding sites of P11a, which are distinct from the pyrethroid binding site but contribute to receptor site 4 for toxins. The change in the spatial structure of domain II as a result of the *kdr* and *super-kdr* mutations may have

a relatively small effect on toxin binding in the interaction between P11a and the sodium channel but may prevent the toxin inactivating the channel. The greater effect on channel structure caused by combining the mutations at L1014 and M918 would be expected to affect P11a binding more than single mutations, in agreement with the lack of sensitivity to P11a/GNA shown by aphid strain 4824J.

As expected, when the calcium channel-specific toxin Pro-Hv1a is fed to aphids, there is no evidence for significant differential sensitivity between insecticide-resistant aphid strains, since the strains differ in mutations to the sodium channel. However, the observation that wild-type aphids are more susceptible to this toxin is unexpected. Mutations in sodium channels present in strains 794J, UKO and 4824J would be expected to result in a fitness cost to *M. persicae*, similar to that observed both for other insect-resistant aphids of this species (Castaneda et al., 2011), and for other insect species (e.g. when comparing in insecticide-resistant and insecticide-susceptible German cockroaches, *Blattella germanica*) (Ang and Lee, 2011). Fitness cost is about energy allocation. It means that the total energy for each aphid is the same. Mutated aphids need more energy to defend pesticides than normal aphids. This will decrease the energy of growth. Therefore, mutated aphids have a poor health compared to normal aphids. A fitness cost for insecticide resistance can be also inferred in *M. persicae* from population data; if there were no fitness cost, the population of resistant *M. persicae* should be much larger than wild type before selection occurs (Fenton et al., 2010). The fitness cost would be expected to make insecticide-resistant strains of *M. persicae* more susceptible to Pro-Hv1a/GNA, but this is not the case. Possibly, other changes to the phenotype of insecticide-resistant aphids are affecting susceptibility to this fusion protein; a transcriptomic study (Silva et al., 2012) has suggested that insecticide resistance in *M. persicae* is complex, and involves a broad array of resistance mechanisms.

The *kdr* strain of *M. persicae* is resistant to all pyrethroids, showing 23-to 73-fold increased resistance (Eleftherianos et al., 2008) and the *kdr* + *super-kdr* strain is virtually immune to all the pyrethroids (Anstead et al., 2004). A fusion protein containing the sodium-channel specific P11a toxin can cause 100% mortality towards pyrethroid-resistant aphids containing a single mutation in the sodium channel if

Chapter 6 Effect of insecticidal fusion proteins containing spider toxins targeting sodium and calcium ion channels on pyrethroid-resistant strains of peach-potato aphid (*Myzus persicae*)

administered at concentrations increased only 3-fold, but is not effective towards aphids containing a double mutation in the sodium channel. However, insecticide-resistant aphids are still sensitive towards a calcium channel-specific toxin, albeit at higher doses than wild-type aphids. These experiments demonstrate the potential for fusion protein-based bio-pesticides to complement existing pesticides, and to be used to control insecticide resistant insect strains; the Pro-Hv1a/GNA fusion protein is currently undergoing trials leading to commercial use as a bio-pesticide.

CHAPTER 7 GENERAL DISCUSSION AND CONCLUSIONS

7.1 Spider venom peptide neurotoxins as new source of bio-insecticides for crop protection

Use of chemical insecticides is currently the dominant approach for controlling insect pests for crop protection. However, in recent years insecticide resistance in pests is developing very fast because a large number of chemical insecticides only affect a very few molecular targets (Tedford et al., 2004a; Raymond-Delpech et al., 2005). For example, most chemical insecticides such as pyrethroids only affect 1-3 amino acids on the sodium ion channel. As a result of heavy use of pesticides, more than 600 insects and mites are resistant to one or more classes of chemical insecticides (Devonshire and Field, 1991; King and Hardy, 2013). Furthermore, due to the perception of environmental protection and human health, legislative decisions dramatically restricted insecticide usage or cancelled application of some first-generation insecticides (King and Hardy, 2013). Therefore, it is necessary to exploit a potential source of novel insecticides, which are environmentally friendly and only have toxic effect on insect pests but not on mammals or humans. Consequently, a large number of proteins that come from insect predators, pathogens and plant defense systems have been developed as insecticidal peptides (Copping and Menn, 2000). Of these, peptide toxins, which target the central nervous system of insect pests derived from venom of spiders, are considered to be potential new bio-insecticides (Tedford et al., 2004b).

Some lectin-proteins derived from plants such as GNA indeed have an advantage as they have the ability to cross the gut epithelium to haemolymph of insect pests. Moreover, GNA also has some insecticidal effects on some species of insect pest. However, according to data presented in this thesis, the toxicities of spider peptide toxins are much more toxic than that of GNA although they are hard to get to the central nervous system of insect pest (Powell et al., 1993; Hilder et al., 1995; Rahbe' et al., 1995; Sauvion et al., 1996; Gatehouse et al., 1996, 1997; Down et al., 1996; Rao et al., 1998; Stoger et al., 1999; Fitches et al., 2001, 2012; Yang et al., 2014a, b). Therefore, spider neurotoxins, as compared to GNA, have more

potential to introduce into commercial agriculture and horticulture if a good delivery system is developed (Chapter 1; Whetstone and Hammock, 2007). There are a number of approaches available in order to delivery these highly toxic spider peptides to get to their target site in central nervous system of insect pest. One of them is including fusion of these toxins to GNA lectin carrier, vectored delivery by using engineered insect pathogens or plant virus proteins (chapter 1). The aim of this project was to investigate the use of new recombinant spider toxins fused to GNA, for the protection of crops against different orders of insect pests. Several different fusion proteins incorporating neurotoxins with GNA (fusion of different toxins with GNA) were expressed successfully using *Pichia* as a host during the work presented here following methodologies presented (Fitches et al., 2002, 2004, 2010, 2012; Trung et al., 2006). They all showed injection or/ and ingestion toxicities against Lepidopteran, Dipteran and Hemipteran insects (Chapter 3, 4, 5 and 6). In this chapter, advantages of these new fusion proteins and the challenges they are encountering in the future commercial application prospect will be discussed.

7.2 The advantages of fusion proteins in the future commercial application

One of the obvious advantages of the fusion proteins is that they can be produced on a large scale by recombinant methods using *Pichia* as an expression host (Fitches et al., 2012; King and Hardy 2013; Yang et al., 2014a). This saves the cost of chemical synthesis and modification thus reducing the price of fusion protein production. If the conditions of production were optimised, the prices of fusion proteins could be reasonable enough to compete with chemical insecticides (King and Hardy, 2013). For example, the yield of Hv1a/GNA is approx. 70% of total protein by yeast fermentation if an optimized high expressing clone is obtained (Pyati et al., 2014). In commercial use, protein purification may not be necessary all the time. This method can save large amount of downstream processing and production costs, which could extremely reduce the price of protein based fusion proteins. Another example is from Vestaron Corporation. They recently reported that some insecticidal spider peptides could be expressed on large scale by yeast fermentation, which led the cost to less than 20 cents per gram (McIntyre, 2011). Furthermore, these peptides could show toxicity similar to chemical insecticides

when used as a foliar spray (McIntyre, 2011).

To summarize, the first application of spider fusion proteins is that they could be developed as products formulated for spray or used as baits. These recombinant proteins can be dissolved into oil-water emulsions for spray into the crops. Emulsions are able to protect proteins being degraded and integrate proteins into the leaves of crops in case that they are washed away by rain. At the same time, fusion protein like Pro-Hv1a/GMA or P11a/GNA can be also used as an insecticide or molluscicidal bait composition, which mixes an insect pest or a mollusc attractant with the fusion protein in order to encourage exposure of pest or slug to the bait (Chapter 4 and 5; Bailey, 2002). This method could be extremely effective against insect pest or slugs.

The second potential advantage of the spider fusion proteins presented here is that they have specific and novel action sites against pests in contrast to chemical insecticides. For example, Pro-Hv1a/GNA has high oral activity against insect pests, which causes quick death or irreversible paralysis of pest within 6 h (Gatehouse et al., 2013). Hence, the fusion proteins should be very effective in control of arthropod pests that have developed resistance to multiple classes of chemical insecticides (King and Hardy, 2013). They can be also useful in the environment where they have the same molecular target as a chemical insecticide to which an insect population has developed resistance. For example, even if pyrethroid-resistant peach potato aphids (mutation in sodium ion channels) reinforce the resistance to both pyrethroids and the P11a/GNA fusion protein. Pro-Hv1a/GNA fusion protein, which targets insect calcium ion channels, could also lead to a complete death at a very low concentration (Chapter 6; Yang et al., 2014b). This means some ion channel sites targeted by most spider fusion proteins, which are different from those targeted by chemical insecticides, could be highly affected by spider fusion proteins. Furthermore, mutations that confer resistance to chemical insecticides can increase susceptibility to fusion proteins that act on different target due to fitness cost (Fenton et al., 2010). Moreover, the pest, which is resistant to chemical insecticides, is more susceptible to some peptide toxins that act on the same target. For example, a pyrethroid-resistant strain of *Heliothis virescens* was more susceptible than non-resistant strains to a recombinant baculovirus expressing AaIT (McCutchen et al., 1997).

The third advantage is that peptides such as P11a and Hv1a isolated from spider

venom to make fusion proteins not only combine a high toxicity for insects with no effects on members of other taxons as a result of evolutionary selection (Vassilevski et al., 2009) they also show no effects in mice after high amount injection (Corzo et al., 2000; Ferrat et al., 2005). Moreover, Pro-Hv1a/GNA, as the most effective fusion protein assayed in the work mentioned here, was proven experimentally to have no detrimental effects on honeybees (Nakasu et al., 2014). This indicates the potential of fusion proteins as alternatives to conventional pesticides in the future. From the analysis of molecular mechanism, although the fusion proteins mainly targets the ion channels of central nervous system, the structural, functional and pharmacological diversity of mammalian ion channels completely differ to that of insect ion channels. Fusion proteins specifically acting on insect ion channels have no relatively effect on human ion channels (Goldin et al., 2000; Song et al., 2004).

In addition, the DNA fragments of spider fusion proteins used in the project are generally less than 600bp. Therefore, genes encoding these mini-fusion proteins can be engineered into a number of entomopathogens, which can make fusion proteins more efficient on killing insect pest (King and Hardy 2013). Firstly, fusion proteins would be expressed and produced systemically in the insect host by the function of entomopathogen infection. Hence spider toxins would get to the action sites more easily than before as both GNA and entomopathogens have the ability to transport these peptides to the haemolymph of insect pest. Secondly, fusion proteins are more toxic than any component, which has been proven before (Fitches et al., 2002, 2004, 2010, 2012; Trung et al., 2006; Yang et al., 2014a, b). Hence, engineering fusion proteins not toxins themselves into entomopathogens, the abilities of engineered entomopathogen on killing pest should be improved a lot, which may be commercially feasible in the field. For example, the fungus *Metarhizium acridum* is valuable as a locust-specific bio-insecticide due to its ability to infect grasshoppers (Charnley and Collins, 2007).

Furthermore, incorporating genes encoding new fusion proteins such as P11a/GNA, Ao1bPro-P11a/GNA, Hv1aPro-P11a/GNA and Pro-Hv1a/GNA (Chapter 3, 4 and 5) into the genome of crop plants is also a feasible approach to enhance the toxicity of spider toxins to defend crop pest. For example, the gene encoding Pro-Hv1a/GNA fusion protein was successfully introduced into *Arabidopsis* (data not shown). This transgenic plant could show significantly enhanced resistance to *M. brassicae* larvae as compared to plant not expressing Pro-Hv1a/GNA (data not

shown). Moreover, because Pro-Hv1a/GNA is much more toxic than Pro-Hv1a or Hv1a component, transgenic crops, which have been engineered to express Pro-Hv1a/GNA fusion protein, should have more activity to resist pest than that have been engineered to express toxin peptide Pro-Hv1a or Hv1a (Gatehouse et al., 2013). Furthermore, as mentioned in Chapter 1, crops expressing Bt toxins can also been engineered to express spider toxins or fusion proteins, as Bt toxins and spider toxins have different mechanisms of action. Hence, if transgenes encoding Bt toxins and spider fusion proteins are engineered together and transferred into plants, the insecticidal activities of these transgenic plants may be remarkably enhanced due to the cumulative effect of Bt toxin and fusion protein. Bt toxins are expected to get fusion proteins across the insect gut into the haemolymph and fusion proteins is expected to induce Bt toxins to kill Hemipteran insects except for Lepidopteran, Coleopteran, Hymenopteran and Dipteran insects (Soberon et al., 2007; Ikonomopoulou and King, 2013; King and Hardy 2013; Yang et al., 2014a).

In addition, the application of bio-pesticides is much more frequent than before from the analysis of the market prospect of pesticides in recent years (Lehr, 2010) (Fig. 7.1). The market share of bio-insecticides is increasing annually although it only accounts for 1% of the world pesticide market (Whalon and Wingerd, 2003). Moreover, the growth rate of bio-insecticide market is significantly higher than that of the conventional pesticide market (Windley et al., 2012). For example, the predicted annual growth rate of conventional pesticide market share was 3.6% from 2009 with a value of approx. USD43 billion, to 2014 with a projected value of approx. USD51 billion (Lehr, 2010). Instead, the predicted annual growth rate of the global bio-insecticide market share is growing more strongly, which was 15.6% from 2009 with a value of USD1.6 billion, to 2014 with an estimated value of approx. USD3.3 billion (Lehr, 2010). These results mean more and more companies and farmers have been interested in the application of bio-insecticides, which will account for more market share than conventional pesticides in the future.

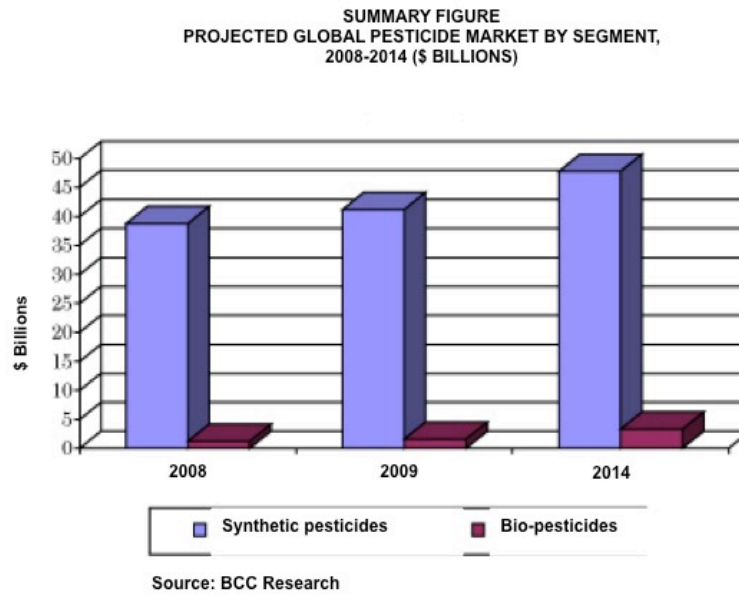

Figure 7.1

Analysis of the market's trends of synthetic pesticides and bio-pesticides, with data for 2008, 2009 and 5-year compound annual growth rates through 2014 from BCC Research (Lehr, 2010).

7.3 The challenges that need to be addressed for toxic spider fusion proteins

Although the fusion proteins have a broad application prospect, several questions remain to be solved. Firstly, although the function of GNA as a “carrier” for making spider neurotoxins orally effective is due to its exocytosis, the function of GNA as a “carrier” for directing correct folding of these toxins is still not fully understood. The only proven function of GNA as a "carrier" in fusion proteins was assumed to result from binding to gut surfaces depending on its carbohydrate binding activity, which was tested experimentally using the method of boiling GNA to denature when incubated with mannose operated by Fitches at 1998 (Fitches and Gatehouse, 1998). Moreover, another function that GNA can direct spider toxins folding properly is still unclear. One possible reason is that spider toxins and GNA could help each other to accomplish their respective folding in the ER. The correct folding of GNA could assist disulphide isomerases of spider toxins when expressed as recombinant fusion proteins in yeast or plants (Back, Ph.D. thesis; unpublished data). For example, the GNA-based fusion protein P11a/GNA in Chapter 4 reached expected toxicity when compared to synthetic P11a (on a molar basis) (Corzo et al., 2000; Yang et al., 2014a).

In addition, some other approaches have been adopted to solve the instability issue of fusion proteins recently. For example, P11a/GNA could be highly expressed as an intact fusion protein by yeast fermentation while Hv1a/GNA was vulnerable to proteolysis during production in the yeast, which meant half of the yields of this fusion protein were lost. To address this issue, one method of site-directed mutagenesis was carried out to remove a potential Kex2 cleavage site. This modification led to increased levels of intact Hv1a/GNA fusion protein expressed in *wild-type P. pastoris* strains and did not affect the toxicity of this fusion towards Lepidopteran larvae (Pyati et al., 2014). Moreover, incorporation of a native Pro-region into Hv1a/GNA construct for the expression of a recombinant fusion protein (Pro-Hv1a/GNA) can result in much higher biological activity, compared to the biological activity of a recombinant toxin produced from a construct without a Pro-region (Hv1a/GNA) (Chapter 5) (Sollod et al., 2005; Gatehouse et al., 2013). Moreover, fusion of synthetic Pro-regions to P11a/GNA also enhanced the toxicity of

this fusion protein although the Pro-region is not native. Therefore, making Pro-spider toxins/GNA is a potential way to improve the activities of spider toxins, which should have a broad application prospect in the future (Gatehouse et al., 2013). Last but not the least, clearance documents from governmental agencies such as ecotoxicological and environmental profiles are necessary for using fusion proteins as bio-insecticides in the farm legally, which also needs large amount of investment (King and Hardy, 2013).

7.4 Conclusions

In summary, the results presented in this thesis have shown that the novel spider fusion proteins are able to offer the potential prospect in the bio-insecticides market due to their advantages introduced above such as low cost, broad-spectrum, no effect on mammals, high oral toxicities against pests including chemical-resistant pests. Moreover, they also have the ability to enhance the toxicities of Bt, entomopathogens and plants against the pests via transgenesis. Therefore, in the future, spider fusion proteins as new bio-pesticides are probable to become an attractive sustainable alternative to the Bt toxin products and conventional chemical pesticides.

References

- Alyokhin, A. (2009). Colorado potato beetle management on potatoes: current challenges and future prospects. *Fruit, Vegetable and Cereal Science and Biotechnology*, 3 (1), 10-19.
- Ambikadevi, D., and Samarjit, R. (1997). Chemical control of red spider mite, *Tetranychus cinnabarinus* Boisduval on okra. *Journal of Tropical Agriculture*, 35 (1/2), 38-40.
- Andreassen, L. D., Kuhlmann, U., Mason, P. G., and Holliday, N. J. (2009). Host range testing of a prospective classical biological control agent against cabbage maggot, *Delia radicum*, in Canada. *Biological Control*, 48 (2), 210-220.
- Ang, L. H., and Lee, C. Y. (2011). Absence of a fitness penalty in insecticide-resistant German cockroaches, *Blattella germanica* (L.) (Dictyoptera: Blattellidae). *International Journal of Pest Management*, 57 (3), 195-204.
- Angus, T. A. (1956). Association of toxicity with protein-crystalline inclusions of *Bacillus sotto* Ishiwata. *Canadian Journal of Microbiology*, 2 (2), 122-131.
- Anstead, J. A., Williamson, M. S., Eleftherianos, I., and Denholm, I. (2004). High-throughput detection of knockdown resistance in *Myzus persicae* using allelic discriminating quantitative PCR. *Insect Biochemistry and Molecular Biology*, 34 (8), 871-877.
- Aronson, A. I., and Shai, Y. (2001). Why *Bacillus thuringiensis* insecticidal toxins are so effective: unique features of their mode of action. *FEMS Microbiology Letters*, 195 (1), 1-8.
- Asaye, M., Biyazen, H., and Girma, M. (2014). Genetic engineering in animal production: Applications and prospects. *Biotechnology and Biochemistry Research*, 2 (2), 12-22.
- Atkinson, R. K., Howden, M. E. H., Tyler, M. I., and Vonarx, E. J. (1999). Insecticidal toxins derived from funnel web (*atrax* or *hadronyche*) spiders, U.S. Patent, Application No. US 08/933,314.
- Back, E. J. (2011). Insecticidal fusion proteins for the control of Coleopteran pests (Doctoral dissertation, Durham University).

References

- Bailey, S. E. R. (2002). Molluscicidal baits for control of terrestrial gastropods. *Molluscs As Crop Pests*, pp. 33-54.
- Baker, D., Sohl, J. L., and Agard, D. A. (1992). A protein-folding reaction under kinetic control. *Nature*, 356 (6366), 263-265.
- Baker, D., Shiau, A. K., and Agard, D. A. (1993). The role of Pro-regions in protein folding. *Current Opinion in Cell Biology*, 5 (6), 966-970.
- Bass, C., and Field, L.M. (2011). Mini Review: Gene amplification and Insecticide Resistance. *Pest Management Science*, 67, 886–890.
- Baum, J. A., Bogaert, T., Clinton, W., Heck, G. R., Feldmann, P., Ilagan, O., ... and Roberts, J. (2007). Control of coleopteran insect pests through RNA interference. *Nature Biotechnology*, 25 (11), 1322-1326.
- Baumgartner, P., Harper, K., Raemaekers, R. J., Durieux, A., Gatehouse, A. M., Davies, H. V., and Taylor, M. A. (2003). Large-scale production and purification of recombinant *Galanthus nivalis agglutinin* (GNA) expressed in the methylotrophic yeast *Pichia pastoris*. *Biotechnology Letters*, 25 (15), 1281-1285.
- Beckmann, M., and Haack, K. J. (2003). Insektizide für die Landwirtschaft: Chemische Schädlingsbekämpfung. *Chemie in unserer Zeit*, 37 (2), 88-97.
- Blackman, R. L. (1974). Life-cycle variation of *Myzus persicae* (Sulz.) (Hom. Aphididae) in different parts of the world, in relation to genotype and environment. *Bulletin of Entomological Research*, 63 (04), 595-607.
- Blackman, R. L., and Eastop, V. F. (1984). Aphids on the world's crops: An identification and information guide. *John Wiley & Sons Ltd, Chichester*, pp. 466.
- Blacquiere, T., Smaghe, G., Van Gestel, C. A., and Mommaerts, V. (2012). Neonicotinoids in bees: a review on concentrations, side-effects and risk assessment. *Ecotoxicology*, 21 (4), 973-992.
- Bloom, D. E. (2011). 7 billion and counting. *Science*, 333 (6042), 562-569.
- Bloomquist, J. R. (2003). Mode of action of atracotoxin at central and peripheral synapses of insects. *Invertebrate Neuroscience*, 5 (1), 45-50.
- Bonning, B. C., and Nusawardani, T. (2007). Introduction to the use of baculoviruses as biological insecticides. *Baculovirus and Insect Cell Expression Protocols*, 388, pp. 359-366.

References

- Bonning, B. C., and Chougule, N. P. (2013). Delivery of intrahemocoelic peptides for insect pest management. *Trends in Biotechnology*, 32 (2), 91-98.
- Bonning, B.C., Pal, N., Liu, S., Wang, Z., Sivakumar, S., Dixon, P.M., King, G.F., Miller, W.A. (2014). Toxin delivery by the coat protein of an aphid-vectored plant virus provides plant resistance to aphids. *Nature Biotechnology*, 32, 102-105.
- Bown, D. P., Wilkinson, H. S., and Gatehouse, J. A. (1997). Differentially regulated inhibitor-sensitive and insensitive protease genes from the phytophagous insect pest, *Helicoverpa armigera*, are members of complex multigene families. *Insect Biochemistry and Molecular Biology*, 27 (7), 625-638.
- Bravo, A., Gill, S. S., and Soberón, M. (2005). *Bacillus thuringiensis* mechanisms and use. *Comprehensive Molecular Insect Science*, 6, 175-205.
- Bravo, A., Gill, S. S., and Soberon, M. (2007). Mode of action of *Bacillus thuringiensis* Cry and Cyt toxins and their potential for insect control. *Toxicon*, 49 (4), 423-435.
- Breman, J. G., Egan, A., Keusch, G. T., and Breman, J. G. (2001). Ears of the hippopotamus: manifestations, determinants, and estimates of the malaria burden. *American Society of Tropical Medicine and Hygiene*, 64, 1-11.
- Bretthauer, R. K., and Castellino, F. J. (1999). Glycosylation of *Pichia pastoris*-derived proteins. *Biotechnology and Applied Biochemistry*, 30 (3), 193-200.
- Bruce, C., Fitches, E. C., Chougule, N., Bell, H. A., and Gatehouse, J. A. (2011). Recombinant conotoxin, TxVIA, produced in yeast has insecticidal activity. *Toxicon*, 58 (1), 93-100.
- Bulut, E., Gocmen, H., Albajes, R., and Sekeroglu, E. (2000). Pests and their natural enemies on greenhouse vegetables in Antalya. *Bulletin OILB/SROP*, 23 (1), 33-37.
- Butt, T. M., Jackson, C., and Magan, N. (Eds.). (2001). *Fungi as biocontrol agents: progress problems and potential*. CABI Publishing, Wallingford, United Kingdom
- Cao, C. W., Liu, G. F., Wang, Z. Y., Yan, S. C., Ma, L., and Yang, C. P. (2010). Response of the gypsy moth, *Lymantria dispar* to transgenic poplar, *Populus simonii* x *P. nigra*, expressing fusion protein gene of the spider

References

- insecticidal peptide and Bt-toxin C-peptide. *Journal of Insect Science*, *10*, 1-13.
- Carlini, C. R., and Grossi-de-Sá, M. F. (2002). Plant toxic proteins with insecticidal properties. A review on their potentialities as bio-insecticides. *Toxicon*, *40* (11), 1515-1539.
- Carter, D. J. (1984). Pest Lepidoptera of Europe: with special reference to the British Isles. *Series Entomology*, *31*, 81–83.
- Casida, J. E., and Quistad, G. B. (1998). Golden age of insecticide research: past, present, or future? *Annual Review of Entomology*, *43* (1), 1-16.
- Castaneda, L. E., Barrientos, K., Cortes, P. A., Figueroa, C. C., Fuentes-Contreras, E., Luna-Rudloff, M., ... and Bacigalupe, L. D. (2011). Evaluating reproductive fitness and metabolic costs for insecticide resistance in *Myzus persicae* from Chile. *Physiological Entomology*, *36* (3), 253-260.
- Catterall, W. A. (2000). From ionic currents to molecular mechanisms: the structure and function of voltage-gated sodium channels. *Neuron*, *26* (1), 13-25.
- Catterall, W. A., Cestèle, S., Yarov-Yarovoy, V., Yu, F. H., Konoki, K., and Scheuer, T. (2007). Voltage-gated ion channels and gating modifier toxins. *Toxicon*, *49* (2), 124-141.
- Cereghino, J.L., Cregg, J.M., (2000). Heterologous protein expression in the methylotrophic yeast *Pichia pastoris*. *FEMS Microbiology Reviews*, *24*, 45-66.
- Cereghino, G. P. L., Cereghino, J. L., Ilgen, C., and Cregg, J. M. (2002). Production of recombinant proteins in fermenter cultures of the yeast *Pichia pastoris*. *Current Opinion in Biotechnology*, *13* (4), 329-332.
- Cestèle, S., Qu, Y., Rogers, J. C., Rochat, H., Scheuer, T., and Catterall, W. A. (1998). Voltage sensor–trapping: enhanced activation of sodium channels by β -scorpion toxin bound to the S3–S4 loop in domain II. *Neuron*, *21* (4), 919-931.
- Cestèle, S., and Catterall, W. A. (2000). Molecular mechanisms of neurotoxin action on voltage-gated sodium channels. *Biochimie*, *82* (9), 883-892.
- Charnley, A. K., and Collins, S. A. (2007). Entomopathogenic Fungi and Their Role in Pest Control. *Environmental and Microbial Relationships*, *4*, pp. 159-187.
- Chen, J., Deng, M., He, Q., Meng, E., Jiang, L., Liao, Z., ... and Liang, S. (2008). Molecular diversity and evolution of cysteine knot toxins of the tarantula

References

- Chilobrachys jingzhao*. *Cellular and Molecular Life Sciences*, 65 (15), 2431-2444.
- Chen, R. (2012). Bacterial expression systems for recombinant protein production: *E. coli* and beyond. *Biotechnology Advances*, 30 (5), 1102-1107.
- Choi, J. Y., Wang, Y., Kim, Y. S., Kang, J. N., Roh, J. Y., Woo, S. D., ... and Je, Y. H. (2008). Insecticidal activities of recombinant *Autographa californica* nucleopolyhedrovirus containing a scorpion neurotoxin gene using promoters from *Cotesia plutellae* bracovirus. *Journal of Asia-Pacific Entomology*, 11 (3), 155-159.
- Chong, Y., Hayes, J. L., Sollod, B., Wen, S., Wilson, D. T., Hains, P. G., ... and Nicholson, G. M. (2007). The omega-atracotoxins: selective blockers of insect M-LVA and HVA calcium channels. *Biochemical Pharmacology*, 74 (4), 623-638.
- Chougule, N. P., Doyle, E., Fitches, E., and Gatehouse, J. A. (2008). Biochemical characterization of midgut digestive proteases from *Mamestra brassicae* (cabbage moth; Lepidoptera: Noctuidae) and effect of soybean Kunitz inhibitor (SKTI) in feeding assays. *Journal of Insect Physiology*, 54 (3), 563-572.
- Chougule, N. P., and Bonning, B. C. (2012). Toxins for transgenic resistance to Hemipteran pests. *Toxins*, 4 (6), 405-429.
- Christopher, B. (1996). The royal horticultural society AZ encyclopedia of garden plants. *Dorling Kindersley, London*, 884-885.
- Ciosi, M., Miller, N. J., Kim, K. S., Giordano, R., Estoup, A., and Guillemaud, T. (2008). Invasion of Europe by the western corn rootworm, *Diabrotica virgifera*: multiple transatlantic introductions with various reductions of genetic diversity. *Molecular Ecology*, 17 (16), 3614-3627.
- Collin, J. E. (1944). The British species of Psilidae (Diptera). *Entomologist's Monthly Magazine*, 80, 214-224.
- Copping, L. G., and Menn, J. J. (2000). Bio-pesticides: a review of their action, applications and efficacy. *Pest Management Science*, 56 (8), 651-676.
- Corzo, G., Escoubas, P., Stankiewicz, M., Pelhate, M., Kristensen, C. P., and Nakajima, T. (2000). Isolation, synthesis and pharmacological characterization of δ -palutoxins IT, novel insecticidal toxins from the spider

References

- Paracoelotes luctuosus* (Amaurobiidae). *European Journal of Biochemistry*, 267 (18), 5783-5795.
- Corzo, G., and Escoubas, P. (2003). Pharmacologically active spider peptide toxins. *Cellular and Molecular Life Sciences*, 60 (11), 2409-2426.
- Corzo, G., Escoubas, P., Villegas, E., Karbat, I., Gordon, D., Gurevitz, M., Nakajima T., Gilles, N. (2005). A spider toxin that induces a typical effect of scorpion alpha-toxins but competes with beta-toxins on binding to insect sodium channels. *Biochemistry*, 44, 1542-1549.
- Cox, J. J., Reimann, F., Nicholas, A. K., Thornton, G., Roberts, E., Springell, K., ... and Woods, C. G. (2006). An SCN9A channelopathy causes congenital inability to experience pain. *Nature*, 444 (7121), 894-898.
- Crickmore, N., Zeigler, D. R., Feitelson, J., Schnepf, E. S. C. H. E. R. I. C. H. I. A., Van Rie, J., Lereclus, D., ... and Dean, D. H. (1998). Revision of the nomenclature for the *Bacillus thuringiensis* pesticidal crystal proteins. *Microbiology and Molecular Biology Reviews*, 62 (3), 807-813.
- Dağlı, F., and Tunç, İ. (2001). Dicofol resistance in *Tetranychus cinnabarinus*: resistance and stability of resistance in populations from Antalya, Turkey. *Pest management science*, 57 (7), 609-614.
- de Marco, A. (2009). Strategies for successful recombinant expression of disulfide bond-dependent proteins in *Escherichia coli*. *Microbial Cell Factories*, 8 (1), 26.
- Denholm, I., and Rowland, M. W. (1992). Tactics for managing pesticide resistance in arthropods: theory and practice. *Annual Review of Entomology*, 37 (1), 91-112.
- Desneux, N., Decourtye, A., and Delpuech, J. M. (2007). The sublethal effects of pesticides on beneficial arthropods. *Annual Review of Entomology*, 52, 81-106.
- Devonshire, A. L., and Field, L. M. (1991). Gene amplification and insecticide resistance. *Annual Review of Entomology*, 36 (1), 1-21.
- Douglas, A. E., and Prosser, W. A. (1992). Synthesis of the essential amino acid tryptophan in the pea aphid (*Acyrtosiphon pisum*) symbiosis. *Journal of Insect Physiology*, 38 (8), 565-568.
- Down, R. E., Gatehouse, A. M., Hamilton, W., and Gatehouse, J. A. (1996). Snowdrop lectin inhibits development and decreases fecundity of the

References

- Glasshouse Potato Aphid (*Aulacorthum solani*) when administered *in vitro* and via transgenic plants both in laboratory and glasshouse trials. *Journal of Insect Physiology*, 42 (11), 1035-1045.
- Down, R. E., Ford, L., Woodhouse, S. D., Raemaekers, R. J., Leitch, B., Gatehouse, J. A., and Gatehouse, A. M. (2000). Snowdrop lectin (GNA) has no acute toxic effects on a beneficial insect predator, the 2-spot ladybird (*Adalia bipunctata* L.). *Journal of Insect Physiology*, 46 (4), 379-391.
- Down, R. E., Fitches, E. C., Wiles, D. P., Corti, P., Bell, H. A., Gatehouse, J. A., and Edwards, J. P. (2006). Insecticidal spider venom toxin fused to snowdrop lectin is toxic to the peach-potato aphid, *Myzus persicae* (Hemiptera: Aphididae) and the rice brown planthopper, *Nilaparvata lugens* (Hemiptera: Delphacidae). *Pest Management Science*, 62 (1), 77-85.
- Du J., Foissac X., Carss A., Gatehouse A.M.R., Gatehouse J.A., (2000). Ferritin acts as the most abundant binding protein for snowdrop lectin in the midgut of rice brown planthoppers (*Nilaparvata lugens*). *Insect Biochemistry and Molecular Biology*, 30, 297-305.
- Du, Y., Lee, J., Nomura, Y., Zhang, T., Zhorov, B., and Dong, K. (2009). Identification of a cluster of residues in transmembrane segment 6 of domain III of the cockroach sodium channel essential for the action of pyrethroid insecticides. *Biochemical Journal*, 419, 377-385.
- Du, Y., Nomura, Y., Satar, G., Hu, Z., Nauen, R., He, S. Y., ... and Dong, K. (2013). Molecular evidence for dual pyrethroid-receptor sites on a mosquito sodium channel. *Proceedings of the National Academy of Sciences*, 110 (29), 11785-11790.
- Eder, J., and Fersht, A. R. (1995). Pro-sequence-assisted protein folding. *Molecular Microbiology*, 16 (4), 609-614.
- Eleftherianos, I., Foster, S. P., Williamson, M. S., and Denholm, I. (2008). Characterization of the M918T sodium channel gene mutation associated with strong resistance to pyrethroid insecticides in the peach-potato aphid, *Myzus persicae* (Sulzer). *Bulletin of Entomological Research London*, 98 (2), 183.
- Emden, H. F. V., Eastop, V. F., Hughes, R. D. and Way, M. J. (1969). The ecology of *Myzus persicae*. *Annual Review of Entomology*, 14 (1), 197-270.

References

- Entwistle, P. F., and Evans, H. F. (1985). Viral control. Comprehensive insect physiology. *Biochemistry and Pharmacology*, 12, 347-412.
- Escoubas, P., Diochot, S., and Corzo, G. (2000a). Structure and pharmacology of spider venom neurotoxins. *Biochimie*, 82 (9), 893-907.
- Escoubas, P., De Weille, J. R., Lecoq, A., Diochot, S., Waldmann, R., Champigny, G., ... and Lazdunski, M. (2000b). Isolation of a tarantula toxin specific for a class of proton-gated Na⁺ channels. *Journal of Biological Chemistry*, 275 (33), 25116-25121.
- Escoubas, P., and Bosmans, F. (2007). Spider peptide toxins as leads for drug development. *Expert Opinion on Drug Discovery*, 2 (6), 823-835.
- Estrada, G., Villegas, E., and Corzo, G. (2007). Spider venoms: a rich source of acylpolyamines and peptides as new leads for CNS drugs. *Natural Product Reports*, 24 (1), 145-161.
- Fenton, B., Margaritopoulos, J. T., Malloch, G. L., and Foster, S. P. (2010). Micro - evolutionary change in relation to insecticide resistance in the peach–potato aphid, *Myzus persicae*. *Ecological Entomology*, 35 (s1), 131-146.
- Ferrat, G., Bosmans, F., Tytgat, J., Pimentel, C., Chagot, B., Gilles, N., Nakajima, T., Darbon, H., Corzo, G. (2005). Solution structure of two insect-specific spider toxins and their pharmacological interaction with the insect voltage-gated Na⁺ channel. *Proteins*, 59, 368-379.
- Finch, S. (1993). Integrated pest management of the cabbage root fly and the carrot fly. *Crop Protection*, 12 (6), 423-430.
- Fitches, E., MR Gatehouse, A., and Gatehouse, J. A. (1997). Effects of snowdrop lectin (GNA) delivered via artificial diet and transgenic plants on the development of tomato moth (*Lacanobia oleracea*) larvae in laboratory and glasshouse trials. *Journal of Insect Physiology*, 43 (8), 727-739.
- Fitches, E., and Gatehouse, J. A. (1998). A comparison of the short and long term effects of insecticidal lectins on the activities of soluble and brush border enzymes of tomato moth larvae (*Lacanobia oleracea*). *Journal of Insect Physiology*, 44 (12), 1213-1224.
- Fitches, E., Woodhouse, S. D., Edwards, J. P., and Gatehouse, J. A. (2001). In vitro and in vivo binding of snowdrop (*Galanthus nivalis* agglutinin; GNA) and jackbean (*Canavalia ensiformis*; Con A) lectins within tomato moth

References

- (*Lacanobia oleracea*) larvae; mechanisms of insecticidal action. *Journal of Insect Physiology*, 47 (7), 777-787.
- Fitches, E., Audsley, N., Gatehouse, J. A., and Edwards, J. P. (2002). Fusion proteins containing neuropeptides as novel insect control agents: snowdrop lectin delivers fused allatostatin to insect haemolymph following oral ingestion. *Insect Biochemistry and Molecular Biology*, 32 (12), 1653-1661.
- Fitches, E., Edwards, M. G., Mee, C., Grishin, E., Gatehouse, A. M., Edwards, J. P., and Gatehouse, J. A. (2004). Fusion proteins containing insect-specific toxins as pest control agents: snowdrop lectin delivers fused insecticidal spider venom toxin to insect haemolymph following oral ingestion. *Journal of Insect Physiology*, 50 (1), 61-71.
- Fitches, E., Wiles, D., Douglas, A. E., Hinchliffe, G., Audsley, N., and Gatehouse, J. A. (2008). The insecticidal activity of recombinant garlic lectins towards aphids. *Insect Biochemistry and Molecular Biology*, 38 (10), 905-915.
- Fitches, E. C., Bell, H. A., Powell, M. E., Back, E., Sargiotti, C., Weaver, R. J., and Gatehouse, J. A. (2010). Insecticidal activity of scorpion toxin (ButaIT) and snowdrop lectin (GNA) containing fusion proteins towards pest species of different orders. *Pest Management Science*, 66 (1), 74-83.
- Fitches, E.C., Pyati, P., King G.F., Gatehouse, J.A., (2012). Fusion to snowdrop lectin magnifies the oral activity of insecticidal ω -hexatoxin-Hv1a peptide by enabling its delivery to the central nervous system. *PLoS One*, 7, e39389.
- Fletcher, J. I., Smith, R., O'Donoghue, S. I., Nilges, M., Connor, M., Howden, M. E., ... and King, G. F. (1997). The structure of a novel insecticidal neurotoxin, ω -atracotoxin-HV1, from the venom of an Australian funnel web spider. *Nature Structural and Molecular Biology*, 4 (7), 559-566.
- Flexner, J. L., Lighthart, B., and Croft, B. A. (1986). The effects of microbial pesticides on non-target, beneficial arthropods. *Agriculture, Ecosystems and Environment*, 16 (3), 203-254.
- Flinn, P. W., Hagstrum, D. W., Reed, C. R., and Phillips, T. W. (2007). Stored Grain Advisor Pro: decision support system for insect management in commercial grain elevators. *Journal of Stored Products Research*, 43 (4), 375-383.
- Foissac, X., Thi Loc, N., Christou, P., Gatehouse, A. M., and Gatehouse, J. A. (2000). Resistance to green leafhopper (*Nephotettix virescens*) and brown planthopper (*Nilaparvata lugens*) in transgenic rice expressing snowdrop

References

- lectin (*Galanthus nivalis* agglutinin; GNA). *Journal of Insect Physiology*, 46 (4), 573-583.
- Frigerio, L., and Roberts, L. M. (1998). The enemy within: ricin and plant cells. *Journal of Experimental Botany*, 49 (326), 1473-1480.
- Froy, O., Zilberberg, N., Chejanovsky, N., Anglister, J., Loret, E., Shaanan, B., ... and Gurevitz, M. (2000). Scorpion neurotoxins: structure/function relationships and application in agriculture. *Pest Management Science*, 56 (5), 472-474.
- Garthwaite DG, Thomas MR, Parrish G, Smith L, Barker I. (2008). Pesticide Usage Survey Report 224, Arable Crops in Britain. DEFRA and Scottish Exec. Environment and Rural Affairs Department.
- Gassmann, A. J., Petzold-Maxwell, J. L., Keweshan, R. S., and Dunbar, M. W. (2011). Field-evolved resistance to Bt maize by western corn rootworm. *PLoS One*, 6 (7), e22629.
- Gatehouse, A. M., Down, R. E., Powell, K. S., Sauvion, N., Rahbé, Y., Newell, C. A., ... and Gatehouse, J. A. (1996). Transgenic potato plants with enhanced resistance to the peach-potato aphid *Myzus persicae*. *Entomologia Experimentalis et Applicata*, 79 (3), 295-307.
- Gatehouse, A. M., Davison, G. M., Newell, C. A., Merryweather, A., Hamilton, W. D., Burgess, E. P., ... and Gatehouse, J. A. (1997). Transgenic potato plants with enhanced resistance to the tomato moth, *Lacanobia oleracea*: growth room trials. *Molecular Breeding*, 3 (1), 49-63.
- Gatehouse, A.M.R., Ferry, N., Edwards, M.G., Bell, H.A. (2011). Insect-resistant biotech crops and their impacts on beneficial arthropods. *Philosophical Transactions of the Royal Society B*, 366, 1438–1452.
- Gatehouse, J.A., Yang, S., Pyati, P., Fitches, E.C. (2013). Pesticidal Fusion Protein Improvements. UK Patent, Applic. No. 1321938.1
- Geng, F., Zhu, W., Anderson, R. A., Leber, B., and Andrews, D. W. (2012). Multiple post-translational modifications regulate E-cadherin transport during apoptosis. *Journal of Cell Science*, 125 (11), 2615-2625.
- Goldin, A. L., Barchi, R. L., Caldwell, J. H., Hofmann, F., Howe, J. R., Hunter, J. C., ... and Catterall, W. A. (2000). Nomenclature of voltage-gated sodium channels. *Neuron*, 28 (2), 365-368.

References

- Gordon, E., Horsefield, R., Swarts, H. G., de Pont, J. J. H., Neutze, R., and Snijder, A. (2008). Effective high-throughput overproduction of membrane proteins in *Escherichia coli*. *Protein Expression and Purification*, 62 (1), 1-8.
- Gratwick, M. (1992). Cabbage root fly. *Crop Pests in the UK*, pp. 237-243.
- Gratz, N. G. (1999). Emerging and resurging vector-borne diseases. *Annual Review of Entomology*, 44 (1), 51-75.
- Gray, S., and Gildow, F. E. (2003). Luteovirus-Aphid Interactions. *Annual Review of Phytopathology*, 41 (1), 539-566.
- Green, M. R., and Sambrook, J. (2012). Molecular cloning: a laboratory manual. Cold Spring Harbor, New York: Cold Spring Harbor Laboratory Press.
- Grist, D.H. (1986). Rice (6th edition). Singapore, Longman Singapore Publishers, pp. 599.
- Gross, M. (2013). EU ban puts spotlight on complex effects of neonicotinoids. *Current Biology*, 23 (11), R462-R464.
- Gubler, D. J. (2002). The global emergence/resurgence of arboviral diseases as public health problems. *Archives of Medical Research*, 33 (4), 330-342.
- Gunning, S. J., Maggio, F., Windley, M. J., Valenzuela, S. M., King, G. F., and Nicholson, G. M. (2008). The Janus-faced atracotoxins are specific blockers of invertebrate K_{Ca} channels. *FEBS Journal*, 275 (16), 4045-4059.
- Hackenberg, D. (2007). Letter from David Hackenberg to American growers. Plattform Imkerinnen, Austria.
- Haefeker, W., and Erwerbssimkerbund, D. B. U. (2000). Betrayed and sold out—German bee monitoring. URL: www.beekeeping.com.
- Hammond, P. (1992). Species inventory. *Global biodiversity*, pp. 17-39.
- Heath, J., and Emmet, A. M. (1979). The Moths and Butterflies of Great Britain and Ireland. *Curwen Books*, 9, Sphingidae - Noctuidae (Pt. 1).
- Hernández-Campuzano, B., Suárez, R., Lina, L., Hernández, V., Villegas, E., Corzo, G., and Iturriaga, G. (2009). Expression of a spider venom peptide in transgenic tobacco confers insect resistance. *Toxicon*, 53 (1), 122-128.
- Higgins, D. R., and Cregg, J. M. (Eds.). (1998). *Pichia* protocols. Totowa, New Jersey: Humana Press, 103, pp. 270.
- Hilder, V. A., Powell, K. S., Gatehouse, A. M. R., Gatehouse, J. A., Gatehouse, L. N., Shi, Y., ... and Boulter, D. (1995). Expression of snowdrop lectin in

References

- transgenic tobacco plants results in added protection against aphids. *Transgenic Research*, 4 (1), 18-25.
- Hoffmann, M., Zemlin, A. E., Meyer, W. P., and Erasmus, R. T. (2008). Hypophosphataemia at a large academic hospital in South Africa. *Journal of Clinical Pathology*, 61 (10), 1104-1107.
- Hogenhout, S. A., Ammar, E. D., Whitfield, A. E., and Redinbaugh, M. G. (2008). Insect vector interactions with persistently transmitted viruses. *Annual Review of Phytopathology*, 46, 327-359.
- Hopkins, B. D., Sato, K., Nakano, A., & Graham, T. R. (1999). Introduction of Kex2 cleavage sites in fusion proteins for monitoring localization and transport in yeast secretory pathway. *Methods in enzymology*, 327, 107-118.
- Ikonomopoulou, M., and King, G. (2013). Natural Born Insect Killers: Spider-venom Peptides and Their Potential for Managing Arthropod Pests. *Outlooks on Pest Management*, 24 (1), 16-19.
- Isbister, G. K., and White, J. (2004). Clinical consequences of spider bites: recent advances in our understanding. *Toxicon*, 43 (5), 477-492.
- Isbister, G.K. and Fan, H.W. (2011). Spider bite. *Lancet*, 378, 2039-2047.
- Jeyaratnam, J. (1990). Acute pesticide poisoning: a major global health problem. *World Health Stat Q*, 43 (3), 139-144.
- Jisha, V. N., Smitha, R. B., and Benjamin, S. (2013). An Overview on the Crystal Toxins from *Bacillus thuringiensis*. *Advances in Microbiology*, 3 (05), 462.
- Jung, M. P., Choi, J. Y., Tao, X. Y., Jin, B. R., Je, Y. H., and Park, H. H. (2012). Insecticidal activity of recombinant baculovirus expressing both spider toxin isolated from *Araneus ventricosus* and *Bacillus thuringiensis* crystal protein fused to a viral polyhedrin. *Entomological Research*, 42 (6), 339-346.
- Kennedy, R. and Collier, R.H. (2000). Pests and diseases of field vegetables. *Pest and Disease Management Handbook* (Alford, D. (ed)), Blackwell Science/British Crop Protection Council, pp. 615.
- Khan, S. A., Zafar, Y., Briddon, R. W., Malik, K. A., and Mukhtar, Z. (2006). Spider venom toxin protects plants from insect attack. *Transgenic Research*, 15 (3), 349-357.
- King, G. F., Tedford, H. W., and Maggio, F. (2002). Structure and function of insecticidal neurotoxins from Australian funnel-web spiders. *Toxin Reviews*,

References

- 21 (4), 361-389.
- King, G. F. (2007). Modulation of insect Cav channels by peptidic spider toxins. *Toxicon*, 49 (4), 513-530.
- King, G. F., and Hardy, M. C. (2013). Spider-venom peptides: structure, pharmacology, and potential for control of insect pests. *Annual Review of Entomology*, 58, 475-496.
- Koehn, J., and Hunt, I. (2009). High-Throughput Protein Production (HTPP): a review of enabling technologies to expedite protein production. *High Throughput Protein Expression and Purification*, Humana Press, pp. 1-18.
- Koutz, P., Davis, G. R., Stillman, C., Barringer, K., Cregg, J., and Thill, G. (1989). Structural comparison of the *Pichia pastoris* alcohol oxidase genes. *Yeast*, 5 (3), 167-177.
- Kranthi, K. R., Jadhav, D. R., Kranthi, S., Wanjari, R. R., Ali, S. S., and Russell, D. A. (2002). Insecticide resistance in five major insect pests of cotton in India. *Crop Protection*, 21 (6), 449-460.
- Kuhn-Nentwig, L., Stöcklin, R., and Nentwig, W. (2011). Venom composition and strategies in spiders: is everything possible? *Advances in Insect Physiology*, 40, 1.
- Lacey, L. A., Frutos, R., Kaya, H. K., and Vail, P. (2001). Insect pathogens as biological control agents: do they have a future? *Biological Control*, 21 (3), 230-248.
- Leger, R. J. S., and Wang, C. (2010). Genetic engineering of fungal biocontrol agents to achieve greater efficacy against insect pests. *Applied Microbiology and Biotechnology*, 85 (4), 901-907.
- Lehr, P. (2010). Bio-pesticides: the global market. *Report code CHM029B BCC Research*.
- Levine, E., Spencer, J. L., Isard, S. A., Onstad, D. W. and Gray, M. E. (2002). Adaptation of the western corn rootworm to crop rotation: evolution of a new strain in response to a management practice. *American Entomologist*, 48 (2), 94-107.
- Li, P., Anumanthan, A., Gao, X. G., Ilangovan, K., Suzara, V. V., Düzgüneş, N., and Renugopalakrishnan, V. (2007). Expression of recombinant proteins in *Pichia pastoris*. *Applied Biochemistry and Biotechnology*, 142 (2), 105-124.

References

- Li, H., Chougule, N. P., and Bonning, B. C. (2011). Interaction of the *Bacillus thuringiensis* delta endotoxins Cry1Ac and Cry3Aa with the gut of the pea aphid, *Acyrtosiphon pisum* (Harris). *Journal of Invertebrate Pathology*, 107 (1), 69-78.
- Liu, S., Zhang, D., Wang, M., Cui, W., Chen, K., Liu, Y., ... and Zhou, Z. (2011). The pro-region of *Streptomyces hygroscopicus* transglutaminase affects its secretion by *Escherichia coli*. *FEMS Microbiology Letters*, 324 (2), 98-105.
- Locke, M., and Nichol, H. (1992). Iron economy in insects: transport, metabolism, and storage. *Annual Review of Entomology*, 37 (1), 195-215.
- Lomer, C. J., Bateman, R. P., Johnson, D. L., Langewald, J., & Thomas, M. (2001). Biological control of locusts and grasshoppers. *Annual review of entomology*, 46 (1), 667-702.
- Lu, B. (2003). Pro-region of neurotrophins: role in synaptic modulation. *Neuron*, 39 (5), 735-738.
- Lu, Y., Wu, K., Jiang, Y., Xia, B., Li, P., Feng, H., ... and Guo, Y. (2010). Mirid bug outbreaks in multiple crops correlated with wide-scale adoption of Bt cotton in China. *Science*, 328 (5982), 1151-1154.
- Mackenzie, J. S., Gubler, D. J., and Petersen, L. R. (2004). Emerging flaviviruses: the spread and resurgence of Japanese encephalitis, West Nile and dengue viruses. *Nature Medicine*, 10, S98-S109.
- Maggio F., and King G.F., (2002a). Role of the structurally disordered N- and C-terminal residues in the Janus-faced atracotoxins. *Toxicon* 40 (9), 1355-1361.
- Maggio, F. and King, G.F. (2002b). Scanning Mutagenesis of a Janus-faced Atracotoxin Reveals a Bipartite Surface Patch That Is Essential for Neurotoxic Function. *Journal of Biological Chemistry* 277 (25), 22806–22813.
- Maggio, F., Sollod, B. L., Tedford, H. W., Herzig, V. and King, G. F. (2010). Spider toxins and their potential for insect control. L. I. Gilbert, and S. S. Gill (Eds.). Academic Press: London, UK, pp. 101-123.
- Makni, H., Bouktila, D., Mezghani, M., and Makni, M. (2011). Hessian fly, *Mayetiola destructor* (Say), populations in the north of tunisia: virulence, yield loss assessment and phenological data. *Chilean Journal of Agricultural Research*, 71 (3), 401-405.

References

- Martinez-Torres, D., Chandre, F., Williamson, M. S., Darriet, F., Berge, J. B., Devonshire, A. L., ... and Pauron, D. (1998). Molecular characterization of pyrethroid knockdown resistance (*kdr*) in the major malaria vector *Anopheles gambiae* s.s. *Insect Molecular Biology*, 7 (2), 179-184.
- Matthews, G. A. (1999). Application of pesticides to crops. London, United Kingdom: Imperial College Press, pp. 325.
- McCaffery, A., and Nauen, R. (2006). The insecticide resistance action committee (IRAC): public responsibility and enlightened industrial self-interest. *Outlooks on Pest Management*, 17 (1), 11-14.
- McCormick, S., Nelson, A., and Nauseef, W. M. (2012). Proconvertase proteolytic processing of an enzymatically active myeloperoxidase precursor. *Archives of Biochemistry and Biophysics*. 527 (1), 31-36.
- McCutchen, B. F., Hoover, K., Preisler, H. K., Betana, M. D., Herrmann, R., Robertson, J. L., and Hammock, B. D. (1997). Interactions of recombinant and wild-type baculoviruses with classical insecticides and pyrethroid-resistant tobacco budworm (Lepidoptera: Noctuidae). *Journal of Economic Entomology*, 90 (5), 1170-1180.
- McGrane, R. C. (1924). The panic of 1837: Some financial problems of the Jacksonian era. The University of Chicago press.
- McIntyre, J. I. (2011). Uses of spider peptides for crop protection. *Presented at 4th Venoms to Drugs Meet*, Heron Island, QLD, Aust.
- Mehlo, L., Gahakwa, D., Nghia, P. T., Loc, N. T., Capell, T., Gatehouse, J. A., ... and Christou, P. (2005). An alternative strategy for sustainable pest resistance in genetically enhanced crops. *Proceedings of the National Academy of Sciences*, 102 (22), 7812-7816.
- Miller GT (2004), *Sustaining the Earth* (6th edition). Thompson Learning, Inc. Pacific Grove, California, 9, pp. 211-216.
- Miller, W. A., and Bonning, B. C. (2007). Plant virus transmission inhibitor and methods. U.S. Patent, Applic. No. 7,312,080.
- Miyazaki, M., Ohyama, K., Dunlap, D. Y., and Matsumura, F. (1996). Cloning and sequencing of the para-type sodium channel gene from susceptible and *kdr*-resistant German cockroaches (*Blattella germanica*) and housefly (*Musca domestica*). *Molecular and General Genetics*, 252 (1-2), 61-68.

References

- Moar, W. J., and Anilkumar, K. J. (2007). Plant science. The power of the pyramid. *Science*, 318 (5856), 1561.
- Morrison, W.P. and Peairs, F.B. (1998). Response model concept and economic impact. In: Quisenberry SS, Peairs FB, eds. Response model for an introduced pest-the Russian wheat aphid. Lanham, MD: Entomological Society of America.
- Morse, R. J., Yamamoto, T., and Stroud, R. M. (2001). Structure of Cry2Aa suggests an unexpected receptor binding epitope. *Structure*, 9 (5), 409-417.
- Mukherjee, A. K., Sollod, B. L., Wikel, S. K., and King, G. F. (2006). Orally active acaricidal peptide toxins from spider venom. *Toxicon*, 47 (2), 182-187.
- Nagadhara, D., Ramesh, S., Pasalu, I. C., Rao, Y. K., Krishnaiah, N. V., Sarma, N. P., ... and Rao, K. V. (2003). Transgenic indica rice resistant to sap-sucking insects. *Plant Biotechnology Journal*, 1 (3), 231-240.
- Nagadhara, D., Ramesh, S., Pasalu, I. C., Rao, Y. K., Sarma, N. P., Reddy, V. D., and Rao, K. V. (2004). Transgenic rice plants expressing the snowdrop lectin gene (GNA) exhibit high-level resistance to the whitebacked planthopper (*Sogatella furcifera*). *Theoretical and Applied Genetics*, 109 (7), 1399-1405.
- Nakasu, E. Y., Williamson, S. M., Edwards, M. G., Fitches, E. C., Gatehouse, J. A., Wright, G. A., and Gatehouse, A. M. (2014). Novel bio-pesticide based on a spider venom peptide shows no adverse effects on honeybees. *Proceedings of the Royal Society B: Biological Sciences*, 281 (1787).
- Newton, D. L., Wales, R., Richardson, P. T., Walbridge, S., Saxena, S. K., Ackerman, E. J., ... and Youle, R. J. (1992). Cell surface and intracellular functions for ricin galactose binding. *Journal of Biological Chemistry*, 267 (17), 11917-11922.
- Ni, Y., and Chen, R. (2009). Extracellular recombinant protein production from *Escherichia coli*. *Biotechnology Letters*, 31 (11), 1661-1670.
- Nicholson, G. M. (2007). Fighting the global pest problem: Preface to the special Toxicon issue on insecticidal toxins and their potential for insect pest control. *Toxicon*, 49 (4), 413-422.
- Novotny, V., Basset, Y., Miller, S. E., Weiblen, G. D., Bremer, B., Cizek, L., and Drozd, P. (2002). Low host specificity of herbivorous insects in a tropical forest. *Nature*, 416 (6883), 841-844.

References

- Nowaczyk, K., Obrepalska-Stepłowska, A., Gawlak, M., Throne, J. E., Olejarski, P., and Nawrot, J. (2009). Molecular techniques for detection of *Tribolium confusum* infestations in stored products. *Journal of Economic Entomology*, 102 (4), 1691-1695.
- Oerke E-C (1994). Estimated crop losses in wheat. In: Oerke E-C, Dehne H-W, Schonbeck F, Weber A, eds. Crop production and crop protection: estimated losses in major food and cash crops. Amsterdam: Elsevier, 179-296.
- Omar, A., and Chatha, K. A. (2012). National Institute for Biotechnology and Genetic Engineering (NIBGE) Genetically Modified Spider Cotton. *Asian Journal of Management Cases*, 9 (1), 33-58.
- Pava-Ripoll, M., Posada, F. J., Momen, B., Wang, C., and St Leger, R. (2008). Increased pathogenicity against coffee berry borer, *Hypothenemus hampei* (Coleoptera: Curculionidae) by *Metarhizium anisopliae* expressing the scorpion toxin (AaIT) gene. *Journal of Invertebrate Pathology*, 99 (2), 220-226.
- Pineda, A., Zheng, S. J., Van Loon, J. J. A., and Dicke, M. (2012). Rhizobacteria modify plant–aphid interactions: a case of induced systemic susceptibility. *Plant Biology*, 14 (s1), 83-90.
- Popova, T. (1993). A study of antibiotic effects on cabbage cultivars on the cabbage moth *Mamestra brassicae* L. (Lepidoptera: Noctuidae). *Entomological Review*, 72, 125-132.
- Porcar, M., Grenier, A. M., Federici, B., and Rahbé, Y. (2009). Effects of *Bacillus thuringiensis* δ -Endotoxins on the Pea Aphid (*Acyrtosiphon pisum*). *Applied and Environmental Microbiology*, 75 (14), 4897-4900.
- Powell, K. S., Gatehouse, A. M. R., Hilder, V. A. and Gatehouse, J. A. (1993). Antimetabolic effects of plant lectins and plant and fungal enzymes on the nymphal stages of two important rice pests, *Nilaparvata lugens* and *Nephotettix cinciteps*. *Entomologia Experimentalis et Applicata*, 66 (2), 119-126.
- Powell, K. S., Gatehouse, A. M. R., Hilder, V. A. and Gatehouse, J. A. (1995). Antifeedant effects of plant lectins and an enzyme on the adult stage of the rice brown planthopper, *Nilaparvata lugens*. *Entomologia Experimentalis et Applicata*, 75 (1), 51-59.

References

- Powell K.S., Spence J., Bharathi M., Gatehouse J.A., Gatehouse A.M.R., (1998). Immunohistochemical and developmental studies to elucidate the mechanism of action of the snowdrop lectin on the rice brown planthopper, *Nilaparvata lugens*. *Journal of Insect Physiology*, 44, 529-539.
- Prosser, W.A., Douglas, A.E., (1992). A test of the hypotheses that nitrogen is upgraded and recycled in an aphid (*Acyrtosiphon pisum*) symbiosis. *Journal of Insect Physiology*, 38, 93–99.
- Pringos, E., Vignes, M., Martinez, J., and Rolland, V. (2011). Peptide neurotoxins that affect voltage-gated calcium channels: a close-up on ω -agatoxins. *Toxins*, 3(1), 17-42.
- Pyati, P., Chellamuthu, A., Gatehouse, A. M., Fitches, E., and Gatehouse, J. A. (2012). Insecticidal activity of wheat Hessian fly responsive proteins HFR-1 and HFR-3 towards a non-target wheat pest, cereal aphid (*Sitobion avenae* F.). *Journal of Insect Physiology*, 58 (7), 991-999.
- Pyati, P., Fitches, E., and Gatehouse, J. A. (2014). Optimising expression of the recombinant fusion protein bio-pesticide ω -hexatoxin-Hv1a/GNA in *Pichia pastoris*: sequence modifications and a simple method for the generation of multi-copy strains. *Journal of Industrial Microbiology and Biotechnology*, 1-11.
- Que, Q., Chilton, M. D. M., de Fontes, C. M., He, C., Nuccio, M., Zhu, T., ... and Shi, L. (2010). Trait stacking in transgenic crops: challenges and opportunities. *GM Crops*, 1(4): 220-229.
- Quistad, G. B., Reuter, C. C., Skinner, W. S., Dennis, P. A., Suwanrumpha, S. and Fu, E. W. (1991). Paralytic and insecticidal toxins from the funnel web spider, *Hololena curta*. *Toxicon*, 29 (3), 329-336.
- Quistad, G. B., and Skinner, W. S. (1994). Isolation and sequencing of insecticidal peptides from the primitive hunting spider, *Plectreurys tristis* (Simon). *Journal of Biological Chemistry*, 269 (15), 11098-11101.
- Raemaekers, R. J., de Muro, L., Gatehouse, J. A., and Fordham-Skelton, A. P. (1999). Functional phytohemagglutinin (PHA) and *Galanthus nivalis* agglutinin (GNA) expressed in *Pichia pastoris*. *European Journal of Biochemistry*, 265 (1), 394-403.
- Rahbé, Y., Sauvion, N., Febvay, G., Peumans, W. J., and Gatehouse, A. M. (1995). Toxicity of lectins and processing of ingested proteins in the pea aphid

References

- Acyrtosiphon pisum*. *Entomologia Experimentalis et Applicata*, 76 (2), 143-155.
- Rajendra, W., Hackett, K. J., Buckley, E., and Hammock, B. D. (2006). Functional expression of Lepidopteran-selective neurotoxin in baculovirus: potential for effective pest management. *Biochimica et Biophysica Acta (BBA)-General Subjects*, 1760 (2), 158-163.
- Rao, K. V., Rathore, K. S., Hodges, T. K., Fu, X., Stoger, E., Sudhakar, D., ... and Gatehouse, J. A. (1998). Expression of snowdrop lectin (GNA) in transgenic rice plants confers resistance to rice brown planthopper. *The Plant Journal*, 15 (4), 469-477.
- Rash, L.D. and Hodgson, W.C. (2002). Review: pharmacology and biochemistry of spider venoms. *Toxicon*. 40, 225–254.
- Rattenholl, A., Lilie, H., Grossmann, A., Stern, A., Schwarz, E., and Rudolph, R. (2001). The pro-sequence facilitates folding of human nerve growth factor from *Escherichia coli* inclusion bodies. *European Journal of Biochemistry*, 268 (11), 3296-3303.
- Raymond-Delpech, V., Matsuda, K., Sattelle, B. M., Rauh, J. J., and Sattelle, D. B. (2005). Ion channels: molecular targets of neuroactive insecticides. *Invertebrate Neuroscience*, 5 (3-4), 119-133.
- Richards, S., Gibbs, R. A., Weinstock, G. M., Brown, S. J., Denell, R., Beeman, R. W., ... and Nguyen, N. (2008). The genome of the model beetle and pest *Tribolium castaneum*. *Nature*, 452 (7190), 949-955.
- Rockets, R. (2007). Down On The Farm? Yields, Nutrients And Soil Quality. URL: www.Scienceagogo.com.
- Roden, D. M., Balsler, J. R., George Jr, A. L., and Anderson, M. E. (2002). Cardiac ion channels. *Annual Review of Physiology*, 64 (1), 431-475.
- Rosenzweig, M. L. (1995). Species diversity in space and time. Cambridge University Press.
- Saez, N. J., Senff, S., Jensen, J. E., Er, S. Y., Herzig, V., Rash, L. D., and King, G. F. (2010). Spider-venom peptides as therapeutics. *Toxins*, 2 (12), 2851-2871.
- Sambrook, J. and Russell, D.W. (2001). Molecular Cloning: A Laboratory Manual. Cold Spring Harbor Laboratory Press. Cold Spring Harbor, NY.

References

- Sanahuja, G., Banakar, R., Twyman, R. M., Capell, T., and Christou, P. (2011). *Bacillus thuringiensis*: a century of research, development and commercial applications. *Plant Biotechnology Journal*, 9 (3), 283-300.
- Sauvion, N., Rahbé, Y., Peumans, W. J., Damme, E. J., Gatehouse, J. A., and Gatehouse, A. M. (1996). Effects of GNA and other mannose binding lectins on development and fecundity of the peach-potato aphid *Myzus persicae*. *Entomologia Experimentalis et Applicata*, 79 (3), 285-293.
- Scott, J. G., Alefantis, T. G., Kaufman, P. E., and Rutz, D. A. (2000). Insecticide resistance in house flies from cage-layer poultry facilities. *Pest Management Science*, 56 (2), 147-153.
- Seal, D. R., Ciomperlik, M., Richards, M. L., & Klassen, W. (2006). Comparative effectiveness of chemical insecticides against the chilli thrips, *Scirtothrips dorsalis* Hood (Thysanoptera: Thripidae), on pepper and their compatibility with natural enemies. *Crop Protection*, 25 (9), 949-955.
- Sertkaya, E., Kaya, K., and Soyulu, S. (2010). Acaricidal activities of the essential oils from several medicinal plants against the carmine spider mite (*Tetranychus cinnabarinus* Boisd.) (Acarina: Tetranychidae). *Industrial Crops and Products*, 31 (1), 107-112.
- Shim, H. J., Choi, J. Y., Li, M. S., Wang, Y., Roh, J. Y., Woo, S. D., ... and Je, Y. H. (2009). A novel recombinant baculovirus expressing insect neurotoxin and producing occlusion bodies that contain *Bacillus thuringiensis* Cry toxin. *Journal of Asia-Pacific Entomology*, 12 (4), 217-220.
- Silva, A.X., Jander, G., Samaniego, H., Ramsey, J.S., and Figueroa, C.C. (2012). Insecticide resistance mechanisms in the green peach aphid *Myzus persicae* (Hemiptera: Aphididae) I: A Transcriptomic Survey. *PLoS One*, 7 (6), e36366.
- Skinner, W. S., Dennis, P. A., Li, J. P., and Quistad, G. B. (1992). Identification of insecticidal peptides from venom of the trap-door spider, *Aptostichus schlingeri* (Ctenizidae). *Toxicon*, 30 (9), 1043-1050.
- Soberón, M., Pardo-López, L., López, I., Gómez, I., Tabashnik, B. E. and Bravo, A. (2007). Engineering modified Bt toxins to counter insect resistance. *Science*, 318 (5856), 1640-1642.
- Sollod B.L., Wilson D., Zhaxybayeva O., Gogarten J.P., Drinkwater R., King G.F. (2005). Were arachnids the first to use combinatorial peptide libraries?

References

- Peptides*, 26 (1), 131-139.
- Song, W., Liu, Z., Tan, J., Nomura, Y., and Dong, K. (2004). RNA editing generates tissue-specific sodium channels with distinct gating properties. *Journal of Biological Chemistry*, 279 (31), 32554-32561.
- St Leger, R. J., Joshi, L., Bidochka, M. J., and Roberts, D. W. (1996). Construction of an improved mycoinsecticide overexpressing a toxic protease. *Proceedings of the National Academy of Sciences*, 93 (13), 6349-6354.
- Stoger, E., Williams, S., Christou, P., Down, R. E., and Gatehouse, J. A. (1999). Expression of the insecticidal lectin from snowdrop (*Galanthus nivalis agglutinin*; GNA) in transgenic wheat plants: effects on predation by the grain aphid *Sitobion avenae*. *Molecular Breeding*, 5 (1), 65-73.
- Tabashnik, B. E., Brévault, T. and Carrière, Y. (2013). Insect resistance to Bt crops: lessons from the first billion acres. *Nature Biotechnology*, 31 (6), 510-521.
- Talekar, N. S., (ed). (1992). Management of Diamondback Moth and Other Crucifer Pests: Proceedings of the Second International Workshop. Shanhua, Taiwan: Asian Vegetable Research and Development Center, pp. 603.
- Tamborindéguy, C., Monsion, B., Brault, V., Hunnicutt, L., Ju, H. J., Nakabachi, A., and Van Fleet, E. (2010). A genomic analysis of transcytosis in the pea aphid, *Acyrtosiphon pisum*, a mechanism involved in virus transmission. *Insect Molecular Biology*, 19 (s2), 259-272.
- Tan, J., Liu, Z., Nomura, Y., Goldin, A. L., & Dong, K. (2002). Alternative splicing of an insect sodium channel gene generates pharmacologically distinct sodium channels. *The Journal of neuroscience*, 22(13), 5300-5309.
- Tan, L., and Grewal, P. S. (2002). Endotoxin activity of *Moraxella osloensis* against the grey garden slug, *Deroceras reticulatum*. *Applied and Environmental Microbiology*, 68 (8), 3943-3947.
- Tedford, H. W., Fletcher, J. I., and King, G. F. (2001). Functional significance of the β -hairpin in the insecticidal neurotoxin ω -atracotoxin-Hv1a. *Journal of Biological Chemistry*, 276 (28), 26568-26576.
- Tedford, H. W., Gilles, N., Ménez, A., Doering, C. J., Zamponi, G. W., and King, G. F. (2004a). Scanning mutagenesis of ω -atracotoxin-Hv1a reveals a spatially restricted epitope that confers selective activity against insect calcium channels. *Journal of Biological Chemistry*, 279 (42), 44133-44140.

References

- Tedford, H. W., Sollod, B. L., Maggio, F., and King, G. F. (2004b). Australian funnel-web spiders: master insecticide chemists. *Toxicon*, *43*(5), 601-618.
- Terlau, H., Shon, K. J., Grilley, M., Stocker, M., Stuehmer, W., and Olivera, B. M. (1996). Strategy for rapid immobilization of prey by a fish-hunting marine snail. *Nature*, *381* (6578), 148-151.
- Tomalski, M. D., Bruce, W. A., Travis, J., and Blum, M. S. (1988). Preliminary characterization of toxins from the straw itch mite, *Pyemotes tritici*, which induce paralysis in the larvae of a moth. *Toxicon*, *26* (2), 127-132.
- Trung, N. P., Fitches, E., and Gatehouse, J. A. (2006). A fusion protein containing a Lepidopteran-specific toxin from the South Indian red scorpion (*Mesobuthus tamulus*) and snowdrop lectin shows oral toxicity to target insects. *BMC Biotechnology*, *6* (1), 18.
- U.S. Environmental Protection Agency (August 30, 2007), Pesticides: Health and Safety. National Assessment of the Worker Protection Workshop #3.
- Van Damme, E.J.M., Allen, A.K. and Peumans, W.J., (1987). Isolation and characterization of a lectin with exclusive specificity towards mannose from snowdrop (*Galanthus nivalis*) bulbs. *FEBS Letters* *215*, 140–144.
- Vassilevski, A. A., Kozlov, S. A., and Grishin, E. V. (2009). Molecular diversity of spider venom. *Biochemistry (Moscow)*, *74* (13), 1505-1534.
- Waldmann, R., Champigny, G., Lingueglia, E., De Weille, J.R., Heurteaux, C. and Lazdunski, M. (1999). H⁺-gated cation channels. *Annals of the New York Academy of Sciences*. *30* (868), 67-76.
- Waldmann, R. (2001). Proton-gated cation channels-neuronal acid sensors in the central and peripheral nervous system. *Advances in Experimental Medicine and Biology*, *502*, 293-304.
- Wan, P., Huang, Y., Wu, H., Huang, M., Cong, S., Tabashnik, B. E., and Wu, K. (2012). Increased frequency of pink bollworm resistance to Bt toxin Cry1Ac in China. *PLoS One*, *7* (1), e29975.
- Wang, X. H., Connor, M., Wilson, D., Wilson, H. I., Nicholson, G. M., Smith, R., ... and King, G. F. (2001). Discovery and structure of a potent and highly specific blocker of insect calcium channels. *Journal of Biological Chemistry*, *276* (43), 40306-40312.

References

- Wang, Z., Zhang, K., Sun, X., Tang, K., and Zhang, J. (2005). Enhancement of resistance to aphids by introducing the snowdrop lectin gene into maize plants. *Journal of Biosciences*, 30 (5), 627-638.
- Waterham, H. R., Digan, M. E., Koutz, P. J., Lair, S. V., and Cregg, J. M. (1997). Isolation of the *Pichia pastoris* glyceraldehyde-3-phosphate dehydrogenase gene and regulation and use of its promoter. *Gene*, 186 (1), 37-44.
- Weber, D. (2003). Colorado beetle: pest on the move. *Pesticide Outlook*, 14 (6), 256-259.
- Weissman, J. S., and Kim, P. S. (1992). The Pro-region of BPTI facilitates folding. *Cell*, 71 (5), 841.
- Wesseler, J., and Fall, E. H. (2010). Potential damage costs of *Diabrotica virgifera virgifera* infestation in Europe-the 'no control' scenario. *Journal of Applied Entomology*, 134 (5), 385-394.
- Whalon, M. E., Sanchez, D., and Duynslager, L. (2003). The database of arthropods resistant to pesticides. *Michigan State University—Center for Integrated Plant Systems*. Disponível em: <http://www.cips.msu.edu/resistance/mdb/index.htm>. Acesso em, 25.
- Whalon, M. E., and Wingerd, B. A. (2003). Bt: mode of action and use. *Archives of Insect Biochemistry and Physiology*, 54 (4), 200-211.
- Whetstone, P.A. and Hammock, B.D. (2007). Delivery methods for peptide and protein toxins in insect control. *Toxicon*, 49, 576-596.
- Whorton, D., Krauss, R.M., Marshall, S., Milby, T. (1977). Infertility in male pesticide workers. *Lancet*, 2, 1259-1261.
- Williamson, M. S., Martinez-Torres, D., Hick, C. A., and Devonshire, A. L. (1996). Identification of mutations in the housefly para-type sodium channel gene associated with knockdown resistance (kdr) to pyrethroid insecticides. *Molecular and General Genetics*, 252, 51-60.
- Wilson, C., and Tisdell, C. (2001). Why farmers continue to use pesticides despite environmental, health and sustainability costs. *Ecological Economics*, 39 (3), 449-462.
- Windley, M. J., Escoubas, P., Valenzuela, S. M., and Nicholson, G. M. (2011). A novel family of insect-selective peptide neurotoxins targeting insect large-conductance calcium-activated K⁺ channels isolated from the venom of the

References

- theraphosid spider *Eucratoscelus constrictus*. *Molecular Pharmacology*, 80 (1), 1-13.
- Windley, M. J., Herzig, V., Dziemborowicz, S. A., Hardy, M. C., King, G. F., and Nicholson, G. M. (2012). Spider-venom peptides as bio-insecticides. *Toxins*, 4 (3), 191-227.
- Woodward, S.R., Cruz, L.J., Olivera, B.M., Hillyard, D.R. (1990). Constant and hypervariable regions in conotoxin propeptides. The *EMBO Journal*, 9 (4), 1015-1020.
- Yamanaka, H., Fuke, Y., Hitotsubashi, S., Fujii, Y., and Okamoto, K. (1993). Functional properties of Pro-region of *Escherichia coli* heat-stable enterotoxin. *Microbiology and Immunology*, 37 (3), 195.
- Yang, S., Pyati, P., Fitches, E., Gatehouse, J.A. (2014a). A recombinant fusion protein containing a spider toxin specific for the insect voltage-gated sodium ion channel shows oral toxicity towards insects of different orders. *Insect Biochemistry and Molecular Biology*, 47, 1-11.
- Yang, S., Fitches, E., Pyati, P., and Gatehouse, J. A. (2014b). Effect of insecticidal fusion proteins containing spider toxins targeting sodium and calcium ion channels on pyrethroid-resistant strains of peach - potato aphid (*Myzus persicae*). *Pest Management Science*, doi: 10.1002/ps.3872.
- Zhao, J. H., Ho, P., and Azadi, H. (2011). Benefits of Bt cotton counterbalanced by secondary pests? Perceptions of ecological change in China. *Environmental Monitoring and Assessment*, 173 (1-4), 985-994.
- Zlotkin, E. (1999). The insect voltage-gated sodium channel as target of insecticides. *Annual Review of Entomology*, 44, 429-45.

Appendices

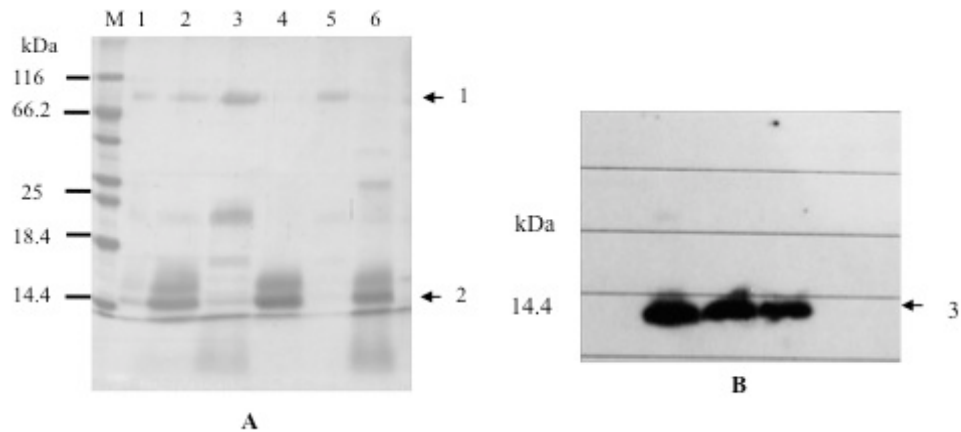

Appendix 1

Analysis of purified Cyrtautoxin (As1c) by 17.5% acrylamide SDS-PAGE gel (A) and western blotting (B). Blots were probed anti-(His)₆ antibodies. **A:** Lanes 1, 3 and 5 are impurities from yeast eluted by 10mM, 25mM and 15mM imidazole, respectively. Lanes 2, 4 and 6 are purified As1c eluted by 200mM imidazole (Lane 4 is the most purified As1c shown on the gel after 25mM imidazole wash first, then 200mM imidazole wash.). Arrow 1, band of cross reactivity with endogenous protein as present in all samples. Arrow 2 and Arrow 3 are As1c on the gel and on the western blotting membrane, respectively.

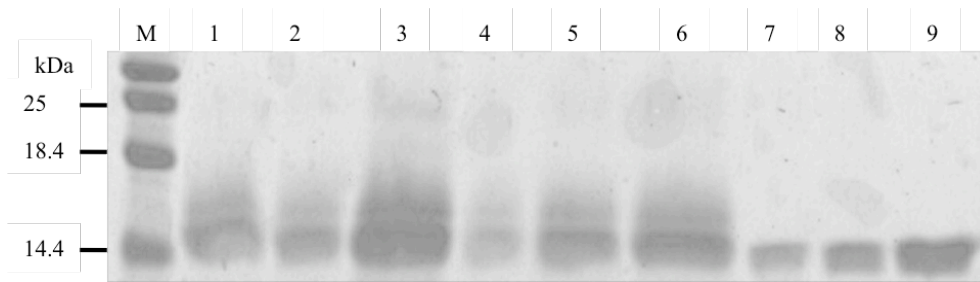

Appendix 2

Quantification of purified As1c by 17.5% acrylamide SDS-PAGE gel. 1 mg crude powder containing As1c protein o dissolved in 200 μ l 1 \times PBS to make 5 μ g / μ l solutions. Lanes 1–3 (Clone 1) are loaded 25, 50, and 100 μ g powder containing As1c, respectively, and lane 2-6 (Clone 2) are also loaded 25, 50, and 100 μ g powder containing As1c respectively, Lanes 7-9 are GNA standards of 1 μ g, 2 μ g and 4 μ g, respectively.

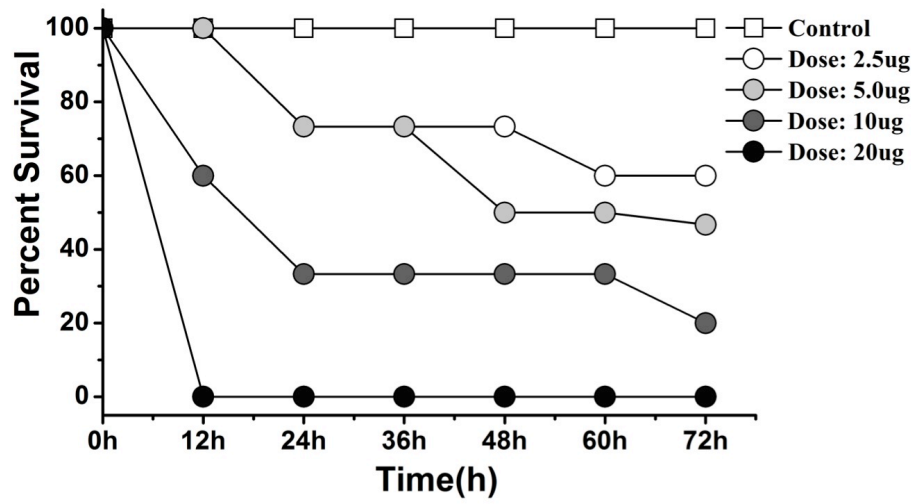

Appendix 3

Survival recorded for fifth stadium larvae of *M. brassicae* following the injection of As1c toxin.

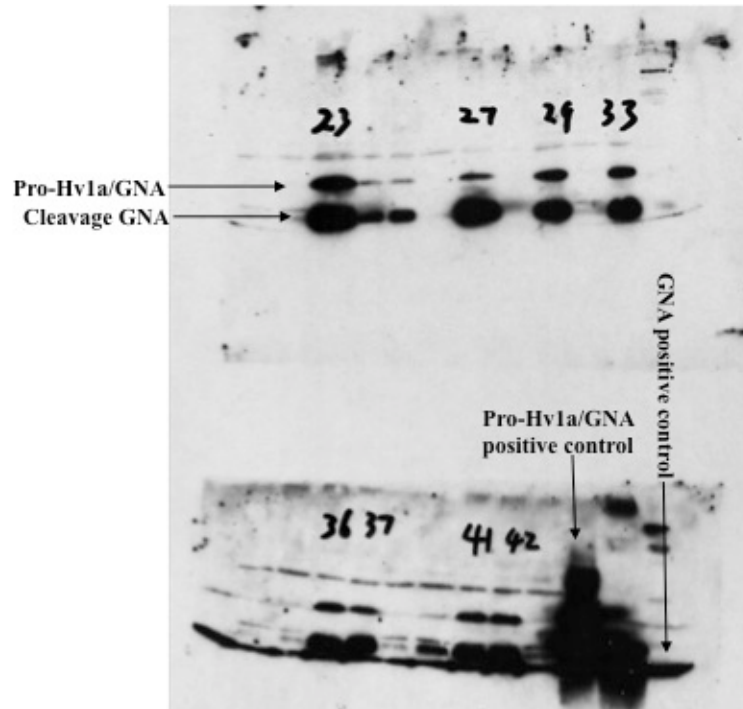

Appendix 4

Western blot (probed with anti-GNA antibodies) to show representative expression of Pro-Hv1a/GNA fusion protein in leaves of transformed *Arabidopsis thaliana* used for feeding bioassays. Total soluble protein from independent T3 homozygous lines (23, 27, 29, 33, 36, 37, 41, 42) plantsoaded onto a 17.5% SDS-PAGE gel at 50 μ g (quantified by BCA assay). Recombinant Pro-Hv1a/GNA and GNA produced in *P. pastoris* were loaded onto the gel as positive controls at 200 ng.

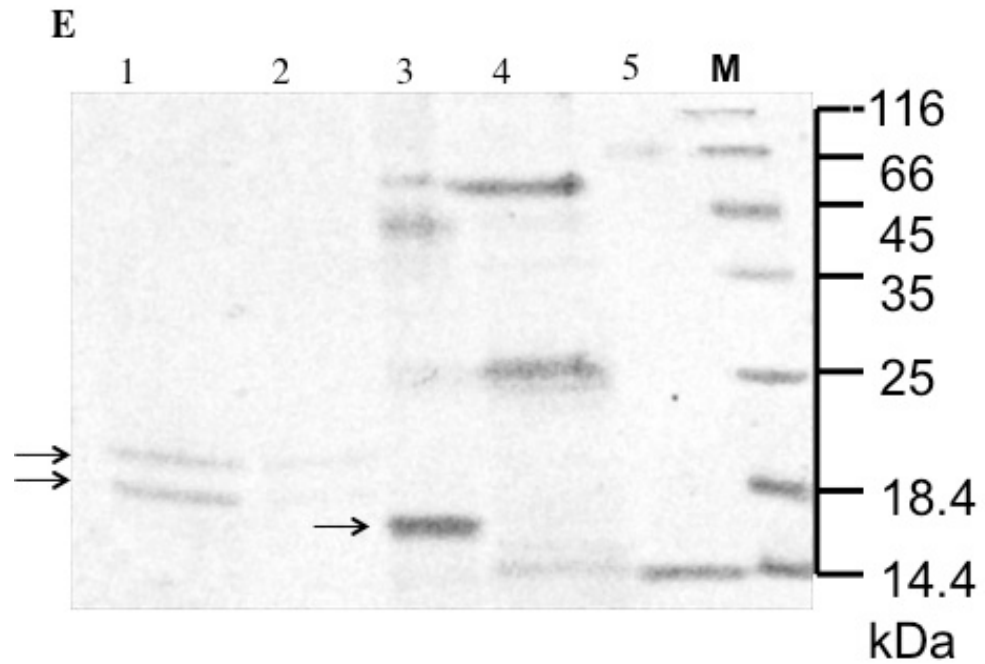

Appendix 5

Characterization of purified recombinant Pro-Ec2a/GNA fusion protein by SDS-PAGE. Pro-Ec2a/GNA and Ec2a/GNA fusion proteins labeled by arrows. Marker is from Thermo Scientific Company. Lane 1 and 2: Pro-Ec2a/GNA; lane 3: Ec2a/GNA; lane 4: Proteins from yeast; lane 5: GNA

H

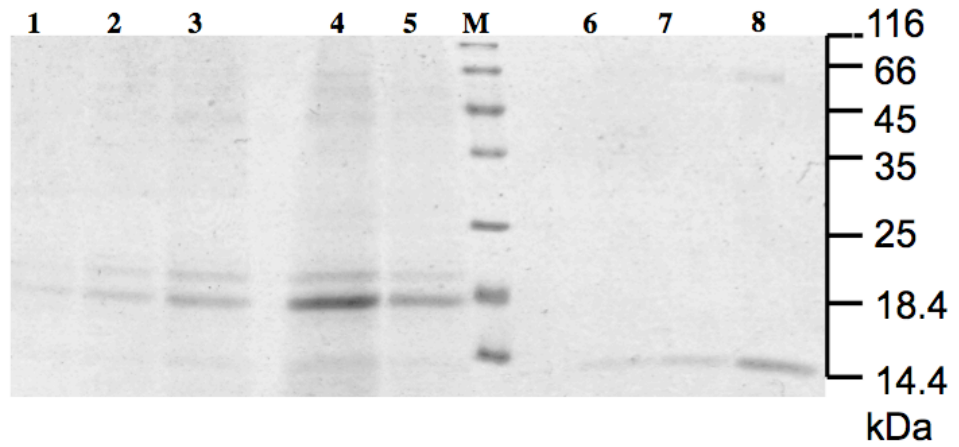

Appendix 6

Quantification of purified recombinant Pro-Ec2a/GNA fusion protein by 17.5% acrylamide SDS- gel. Lanes 1–5 are loaded 6.25, 12.5, 25, 100 and 50 μg powder containing Pro-Ec2a/GNA, respectively; Lanes 6-8 are GNA standards of 1 μg , 2 μg and 4 μg .

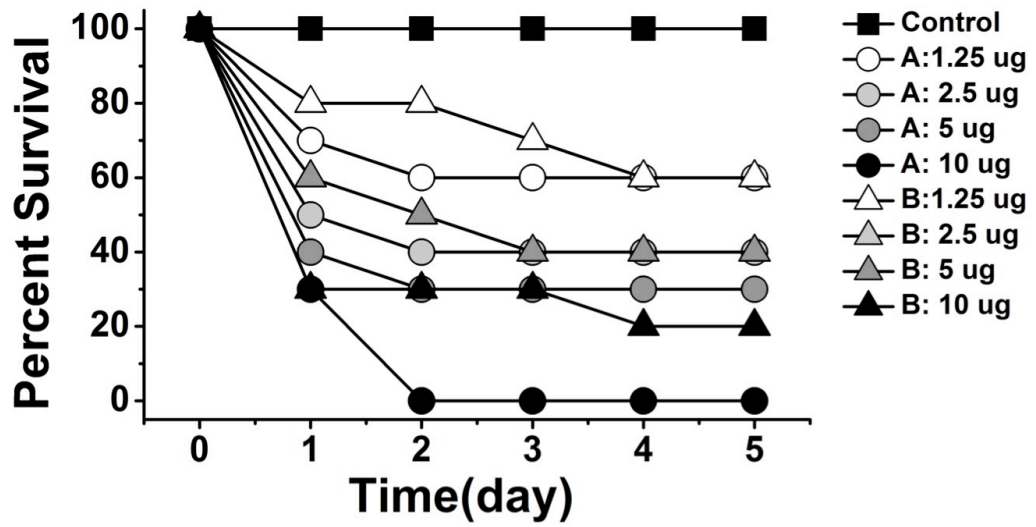

Appendix 7

Survival of fifth stadium *M. brassicae* larvae following injection of different doses of Pro-Ec2a/GNA and Ec2a/GNA. Dose A: Pro- Ec2a/GNA; Dose B: Ec2a/GNA. 2.5 μg of Dose B is overlapped by 5 μg of Dose B. N=20 per treatment.

Appendix 8

Publication 1: A recombinant fusion protein containing a spider toxin specific for the insect voltage-gated sodium ion channel shows oral toxicity towards insects of different orders.

Publication 2: Effect of insecticidal fusion proteins containing spider toxins targeting sodium and calcium ion channels on pyrethroid-resistant strains of peach-potato aphid (*Myzus persicae*).

UK Patent: Pesticidal Fusion Protein Improvements. **Applic. No. 1321938.1**



A recombinant fusion protein containing a spider toxin specific for the insect voltage-gated sodium ion channel shows oral toxicity towards insects of different orders



Sheng Yang^a, Prashant Pyati^a, Elaine Fitches^b, John A. Gatehouse^{a,*}

^aSchool of Biological and Biomedical Sciences, Durham University, South Road, Durham DH1 3LE, UK

^bFera (Food and Environment Research Agency), Sand Hutton, York, UK

ARTICLE INFO

Article history:

Received 2 January 2014

Accepted 21 January 2014

Keywords:

Neurotoxin

Insecticide

Recombinant protein expression system

Protein transport

Crop protection

Biotechnology

ABSTRACT

Recombinant fusion protein technology allows specific insecticidal protein and peptide toxins to display activity in orally-delivered biopesticides. The spider venom peptide δ -amaurobitoxin-PI1a, which targets insect voltage-gated sodium channels, was fused to the “carrier” snowdrop lectin (GNA) to confer oral toxicity.

The toxin itself (PI1a) and an amaurobitoxin/GNA fusion protein (PI1a/GNA) were produced using the yeast *Pichia pastoris* as expression host. Although both proteins caused mortality when injected into cabbage moth (*Mamestra brassicae*) larvae, the PI1a/GNA fusion was approximately 6 times as effective as recombinant PI1a on a molar basis. PI1a alone was not orally active against cabbage moth larvae, but a single 30 μ g dose of the PI1a/GNA fusion protein caused 100% larval mortality within 6 days when fed to 3rd instar larvae, and caused significant reductions in survival, growth and feeding in 4th – 6th instar larvae. Transport of fusion protein from gut contents to the haemolymph of cabbage moth larvae, and binding to the nerve chord, was shown by Western blotting. The PI1a/GNA fusion protein also caused mortality when delivered orally to dipteran (*Musca domestica*; housefly) and hemipteran (*Acyrtosiphon pisum*; pea aphid) insects, making it a promising candidate for development as a biopesticide.

© 2014 The Authors. Published by Elsevier Ltd. Open access under [CC BY license](http://creativecommons.org/licenses/by/4.0/).

1. Introduction

Synthetic pesticides have been widely used for crop protection against herbivorous insects in intensive agricultural production, and are a necessary input to achieve high yields and consequent food security. However, there are widely held concerns over the indiscriminate use of pesticides in general, and insecticides in particular, including the development of resistance in target pests, detrimental effects in non-pest and beneficial insects, contamination of watercourses and the poisoning of higher animals. Therefore, many of the older, broad-spectrum insecticidal compounds have been, or are likely to be, withdrawn (Denholm and Rowland, 1992; Casida and Quistad, 1998; Desneux et al., 2007). Protein-based biopesticides fulfil many of the criteria required for more environmentally compatible approaches to pest control, since they combine efficacy with specificity, and are biodegradable in the environment. Besides naturally occurring protein biopesticides such as *Bacillus thuringiensis* toxins, biotechnological methods can

be used to produce recombinant proteins with insecticidal activity. These include insecticidal fusion proteins containing a toxic peptide or protein fused to a “carrier”, where the carrier confers oral activity on a toxin that must normally be injected into the insect to reach its site of action, by directing transport of the fusion across the insect gut (Fitches et al., 2004).

Venoms isolated from a range of arachnids have been shown to contain proteins which are biologically active toxins when injected into potential prey. Most are small proteins, in the range 30–70 amino acid residues (variously referred to as peptides or proteins), that principally target neuronal ion channels, and to a lesser extent neuronal receptors and presynaptic membrane proteins, to cause paralysis of the prey (Rash and Hodgson, 2002). As a result of evolutionary selection, some toxins combine a high toxicity for insects with no effects on members of other taxons (Vassilevski et al., 2009). The potency and selective mode of action of spider neurotoxins would make them ideal candidates for use in environmentally compatible pest management technologies, if a suitable delivery system could be devised (Whetstone and Hammock, 2007). In general, these toxins are not effective as oral or contact insecticides, and no system which requires injection could possibly be feasible in the field.

* Corresponding author. Tel.: +44 191 334 1264; fax: +44 191 334 1201.

E-mail address: J.A.Gatehouse@durham.ac.uk (J.A. Gatehouse).

Biopesticides used for crop protection against insect pests generally function via oral delivery, with the toxin proteins present in, or sprayed on plant tissues susceptible to damage. The use of a “carrier” in recombinant fusion proteins leads to transport of toxin proteins from the gut contents across the insect gut epithelium to the central nervous system where the toxin is active, resulting in dramatically enhanced oral insecticidal activity (Fitches et al., 2002). The mannose-specific lectin from snowdrop (*Galanthus nivalis* agglutinin: GNA) has proved successful as a carrier. It is resistant to proteolytic activity in the insect gut, and can bind to gut epithelial glycoproteins, leading to transport into the haemolymph following ingestion. For example, a toxin protein from the spider *Segestria florentina* was delivered to the haemolymph of lepidopteran larvae after oral delivery by fusing to GNA, causing decreased survival and growth in insects fed on diet containing the fusion protein (Fitches et al., 2004). Fusion proteins are required to possess good stability, so they cannot be degraded in the environment or digested by gut enzymes of pests, and high toxicity, with activity towards pests comparable to the toxin proteins themselves.

δ -Amaurobitoxins, or δ -palutoxins, from the spider *Pireneitega luctuosus* (Araneae: Amaurobiidae; previously referred to as *Paracoelotes luctuosus*) are a family of four similar 36–37 residue peptides, designated P1a–d (Corzo et al., 2000). They contain 8 cysteine residues, which are disulphide-linked to form a cysteine knot motif. The δ -amaurobitoxins are effective insecticides, with an estimated LD50 values of 0.95–4.48 μ g/100 mg when injected into lepidopteran larvae (oriental leafworm moth; *Spodoptera litura*). They show insect-specific toxicity, with no effects observed for P1a, P1c and P1d after intravenous injection in mice. The amaurobitoxins specifically target insect sodium channels, and their solution structure has elucidated the nature of the interaction (Corzo et al., 2005; Ferrat et al., 2005). The toxin P1a was selected as the subject of this study as it combines the highest insecticidal activity with no observed toxicity towards higher animals, and thus would be suitable as a biopesticide.

The present paper reports the production, purification and biological activity of recombinant δ -amaurobitoxin P1a, and the fusion protein P1a/GNA comprised of P1a linked to the N-terminus of GNA. It shows that fusion to GNA enhances the insecticidal activity of P1a. Not only was fusion protein more toxic than recombinant P1a when injected into cabbage moth (*Mamestra brassicae*) larvae, but it also had effective oral toxicity when the toxin alone did not. The fusion protein was also orally toxic to insects of different orders, pea aphids (*Acyrtosiphon pisum*; Hemiptera) and housefly (*Musca domestica*; Diptera). The P1a/GNA fusion protein has potential to be a useful biopesticide for crop protection in the future.

2. Materials and methods

2.1. Materials

Chemicals and reagents were of analytical grade and were supplied by Sigma or BDH Chemical Company otherwise unless stated. Restriction enzymes and other molecular biology reagents were supplied by Fermentas. A double stranded DNA incorporating a sequence encoding the mature P1a toxin (P83256), with codon usage optimised for yeast, was designed by the authors, synthesised and supplied by ShineGene Molecular Biotech, Inc. (Shanghai 201109, China; <http://www.synthesogene.com/>) in the vector pUC57. Other oligonucleotides were supplied by Sigma Chemical Co. Recombinant snowdrop lectin was produced by the authors by expression in *Pichia pastoris*, as described by Baumgartner et al. (2004).

Mamestra brassicae (cabbage moth) were maintained in a licenced growth facility. The cultures were subject to a 16 h light, 8 h dark cycle and maintained at 25 °C, 40% relative humidity on a standard lepidopteran diet as described before (Bown et al., 1997). *M. domestica* (housefly) larvae were maintained on a wheat flour diet under similar conditions; adults were given 10% sucrose solution *ad libitum*. *A. pisum* (pea aphid) was cultured on plants of *Vicia faba* (broad bean cv. Sutton Dwarf) under conditions of 12 h light, 12 h dark, 18 °C, 70% relative humidity.

2.2. Expression constructs

The P1a coding sequence was transferred from pUC57 to the yeast expression vector pGAPZ α B (Invitrogen; www.invitrogen.com) by digestion with *Pst*I and *Xba*I, isolation of the coding sequence fragment by agarose gel electrophoresis, followed by ligation to pGAPZ α B which had been restricted with the same enzymes. DNA fragments were separated by agarose gel electrophoresis prior to ligation, and were purified from excised gel slices using a QuiaQuick Gel Extraction Kit (Qiagen; www.qiagen.com) as described in the manufacturer's protocol. After ligation, the resulting recombinant plasmid was cloned using standard protocols by transformation of electro-competent cells of *E. coli* (Sambrook and Russell, 2001). Selected clones were checked for correct assembly of the construct by DNA sequencing.

To produce a construct encoding the P1a/GNA fusion protein, the mature P1a coding sequence from a verified expression construct in pGAPZ α B was excised by digestion with *Pst*I and *Not*I, and purified by agarose gel electrophoresis as described above. A pGAPZ α B plasmid containing the fusion protein construct Hv1a/GNA (Fitches et al., 2012) was digested with *Pst*I and *Not*I to remove the Hv1a coding sequence, and purified by agarose gel electrophoresis. The Hv1a coding sequence was then replaced by P1a by ligating the purified fragments, and cloning the resulting recombinant plasmid. Selected clones containing the expression vector encoding the P1a/GNA fusion protein were verified by DNA sequencing. All DNA sequencing was carried out using Applied Biosystems ABI Prism 3730 automated DNA sequencers by DBS Genomics, School of Biological and Biomedical Sciences, Durham University, UK.

2.3. Expression of P1a and P1a/GNA fusion proteins in yeast

pGAPZ α plasmids containing the P1a and P1a/GNA expression constructs were amplified in *E. coli*, purified and linearised with *Bln*I. Linearised plasmids were transformed into *Pichia pastoris* strain SMD1168H (Invitrogen) using the EasyComp Transformation kit (Invitrogen) as described in the manufacturer's protocol. Transformed yeast clones were plated and selected on YPG agar plates (1% yeast extract (w/v), 2% peptone (w/v), 4% glycerol (v/v), 1.5% agar (w/v)) containing zeocin (100 μ g/ml). Selected clones (at least 10 for each construct) were checked for expression of recombinant proteins by analysis of culture supernatant from small-scale shake flask cultures grown for 2–3 days in YPG–zeocin media at 30 °C. Samples of supernatant were separated by SDS-polyacrylamide gel electrophoresis; gels were blotted onto nitrocellulose and probed with anti-(His)₆ primary antibodies (Bio-Rad) or anti-GNA primary antibodies, followed by washing, probing with HRP-conjugated secondary antibodies (Bio-Rad), and detection of bound antibodies by ECL, as described previously (Fitches and Gatehouse, 1998).

Selected clones of *P. pastoris* containing the integrated P1a and P1a/GNA constructs were grown in a 7.5 L BioFlo 110 bench-top fermenter (New Brunswick Scientific). For fermentation, two 100 ml YPG cultures of *P. pastoris* containing toxin or fusion genes

were grown for 2–3 days at 30 °C with shaking, prior to being used to inoculate 2.5 L of sterile minimal media supplemented with PTM1 salts. Cultivation at 30 °C, 30% dissolved oxygen; pH 4.5 with continuous agitation was continued with a glycerol feed (5–10 ml/h) over a period of 4 days (Fitches et al., 2004). Culture supernatant was separated from cells by centrifugation (20 min at 5000 g), filtered through GF/D and GF/F glass fibre membranes (Whatman) and adjusted to 0.02 M sodium phosphate buffer, 0.4 M sodium chloride, pH 7.4 by adding 4× concentrated stock.

Recombinant proteins were purified from clarified culture supernatant by nickel affinity chromatography on 5 ml HisTrap crude nickel columns (GE Healthcare) with a flow rate of 2 ml/min. After loading, the columns were washed with 0.02 M sodium phosphate buffer, 0.4 M sodium chloride pH 7.4 and the bound proteins were eluted with 0.2 M imidazole in the same buffer. Eluted proteins were checked for purity by SDS-PAGE, dialysed against deionised water using multiple changes to remove all small molecules, and freeze-dried.

2.4. Protein characterisation

Amounts of recombinant proteins were quantitatively estimated by comparison to known amounts of GNA standards run on SDS-PAGE gels, or by BCA analysis using a BCA™ Protein Assay Kit (Thermo Scientific). For N-terminal sequencing, proteins were separated by SDS-PAGE and blotted onto PVDF membrane. Excised bands were supplied for N-terminal sequencing to a commercial protein sequencing service (Shanghai Applied Protein Technology Co., Ltd, China). For further characterisation, recombinant PI1a and PI1a/GNA fusion protein were denatured by dissolving in 6 M urea and incubating at room temperature for 15 min prior to addition of SDS-sample buffer, and analysis by SDS-PAGE.

The presence of N-linked glycosylation on recombinant proteins was shown by treatment with PNGase F, using a deglycosylation kit from Biolabs Co., Ltd, UK as described in the manufacturer's protocol. 1 µl Glycoprotein Denaturing Buffer was added to 6 µg protein (dissolved in 5 µl 1× PBS), and the mixture was incubated 10 min at 100 °C. After cooling, 2 µl 10× G7 Reaction Buffer, 2 µl 10% NP40 and 1.5 µl PNGase F were added to a final volume of 20 µl, and the mixture was incubated at 37 °C for 1 h. The proteins were then analysed by SDS-PAGE. A reaction in which PNGase was omitted was used as a control.

2.5. Bioassays on cabbage moth larvae

Injection bioassays were carried out using 4–5th stadium *M. brassicae* larvae (approx. 45–55 mg in weight) by injecting 5 µl of aqueous solution containing varying doses of PI1a and PI1a/GNA dissolved in 1× PBS (phosphate buffered saline; 0.15 M NaCl, 0.015 M sodium-phosphate buffer, pH 7.2). Controls were injected with 5 µl 1× PBS. For each dose, 30 larvae were injected and paralysis and mortality were scored at 12, 24, 36, 48, 60 and 72 h post injection including control. To estimate LD₅₀ values, mortality at 48 h was used, to make results comparable to those of Corzo et al. (2000).

Droplet-feeding assays were conducted to assess the oral activity of PI1a/GNA towards *M. brassicae* third to sixth instar larvae. Larvae were fed once with a 2 µl droplet containing 20 or 30 µg of PI1a/GNA, 30 µg of PI1a, or 30 µg of GNA in 1× PBS and 10% sucrose. Smaller larvae had exposed repeatedly until they finished the 2 µl droplet. Control larvae were fed on droplets containing 1× PBS and 10% sucrose solution. Treated larvae were placed in ventilated plastic pots (250 ml) with standard artificial diet after consumption of the droplet. To encourage droplet consumption, larvae were starved for approx. 24 h prior to feeding. Larval weight and survival was recorded daily after droplet feeding. In experiments to

determine effect on feeding, the artificial diet was weighed prior to introduction, and re-weighed on removal to determine the amount consumed; diet was replaced daily.

To study fusion protein uptake into insects, fifth instar larvae were droplet-fed with a sub-lethal dose (20 µg) of PI1a/GNA fusion protein as described above, and then transferred back to standard rearing diet, to give a “feed-chase” experiment. Haemolymph samples were extracted from *M. brassicae* larvae at different intervals (2–72 h) after feeding as described previously (Fitches et al., 2012), and the extracted haemolymph was quantified for protein content (BCA™ Protein Assay Kit, Pierce; www.piercenet.com). Tissues (midgut, Malpighian tubules, fat body, nerve chord) were dissected from selected larvae, and extracted as described previously (Fitches et al., 2012). Western blotting of larval haemolymph and tissue samples was carried out using anti-GNA antibodies (1:3300 dilution) as described previously (Fitches et al., 2001). Similar methods were used to follow the fate of PI1a/GNA fusion protein (20 µg doses) injected into the haemolymph of 5th instar *M. brassicae* larvae.

2.6. Bioassays on houseflies

Adults of *M. domestica* were injected with 1.0 µl of aqueous solution containing varying doses of PI1a and PI1a/GNA dissolved in 1× PBS, using a conventional Hamilton syringe with a fine needle. Survival was monitored over a 144 h period. In feeding assays, adult flies were allowed to feed from cotton pads which had been soaked in a solution containing varying concentrations of PI1a/GNA in 60% sucrose; survival was monitored over a 120 h period in which flies were exposed continuously to the treatment.

2.7. Bioassays on pea aphids

The toxicity of proteins to *A. pisum* was determined by bioassay using a liquid artificial diet (Prosser and Douglas, 1992), using a parafilm sachet to deliver diet to insects. Proteins were dissolved in sterile diet at known concentrations. The standard assay used 1–2 day-old aphid nymphs, which had been conditioned by transfer to diet without added proteins prior to receiving the protein treatments, and continued the assay until the insects became mature. For experiments to investigate retention of proteins in aphids, PI1a/GNA, PI1a and GNA were labelled with fluorescein isothiocyanate (FITC) by mixing together equimolar concentrations of FITC (solution in dimethyl sulphoxide) and PI1a/GNA, PI1a and GNA (solutions in 1× PBS) (0.02 mg of FITC/mg of PI1a/GNA, 0.04 mg of FITC/mg of PI1a and 0.03 mg of FITC/mg of GNA, respectively). Aphids were fed on diets containing labelled proteins for 24 h, then transferred to control diet for a “chase” period of up to 48 h. Labelled proteins were detected by fluorescence microscopy of whole insects.

2.8. Statistical analysis

Survival data were analysed using Kaplan–Meier survival analysis, using Prism (v. 5) software. All other data analysis was carried out using Origin 8.5 graphing and data analysis software. ANOVA analysis (with Bonferroni–Dunn post-hoc tests) was carried out to determine any significant differences between treatments in the parameters measured.

3. Results

3.1. Expression and purification of recombinant PI1a and PI1a/GNA

Expression constructs for production of recombinant proteins in the methylotrophic yeast *Pichia pastoris* were based on the vector

pGAPZ α , which contains a constitutively expressed promoter and integrates into the yeast genome at the *GAPDH* locus, giving stable transformants. The expression construct for production of recombinant P11a contained a synthetic coding sequence corresponding to the published amino acid sequence for the toxin, arranged in-frame C-terminal to a sequence encoding the yeast α -factor prepro-sequence, and N-terminal to sequences encoding the myc epitope and (His) $_6$ tag, supplied by the vector (Fig. 1A). The expression construct for production of recombinant P11a/GNA fusion protein contained the same synthetic mature P11a coding sequence fused to the N-terminus of a coding sequence corresponding to residues 1–105 of mature snowdrop lectin (GNA) via a 3 amino acid linker peptide; again, the fusion protein was arranged in-frame C-terminal to the α -factor prepro-sequence, and N-terminal to a sequence encoding the (His) $_6$ tag, supplied by the vector (Fig. 1B). The constructs were assembled by restriction-ligation and were checked by DNA sequencing after cloning.

Verified clones of expression constructs were transformed into the protease-deficient *P. pastoris* strain SMD1168H, using antibiotic (zeocin) selection for transformants. Approx. 50 resistant colonies were obtained for each expression construct. Culture supernatant from selected clones grown in shake-flask cultures was analysed for production of recombinant proteins by Western blotting, to allow selection of clones producing the highest levels of P11a and P11a/GNA. Screening of large numbers of transformed yeast clones was not necessary, since most clones were expressing recombinant proteins, as judged by the presence of immunoreactive bands of the expected size on Western blots of culture supernatants.

For each construct, the best-expressing clone of those screened in small-scale cultures was selected for large-scale protein production by bench top fermentation. Culture supernatants were purified by nickel affinity chromatography, and eluted peaks were desalted by dialysis, and lyophilized. Yields of recombinant proteins were comparable to other fusion proteins prior to optimisation; P11a was produced at approx. 26 mg/L and P11a/GNA at approx. 21 mg/L, as estimated by semi-quantitative SDS-PAGE.

Purified recombinant proteins were analysed by SDS-PAGE and western blot. The recombinant toxin P11a (Fig. 2A) ran as a closely spaced double band at an indicated mol. wt. of approx. 18 kDa on normal SDS-PAGE gels; both bands were immunoreactive with anti-(His) $_6$ antibodies on Western blotting (not presented). The predicted mol. wt. of recombinant P11a, including the tag sequences is 7.07 kDa. The double band and incorrect mol. wt. of toxin was reproducible with different gels, samples, and use of reducing agents prior to electrophoresis, but was considered to be an artefact of the gel system, possibly as a result of poor binding of SDS to the polypeptide. When the same samples were treated with 6 M urea prior to electrophoresis, P11a gave a single band at an indicated

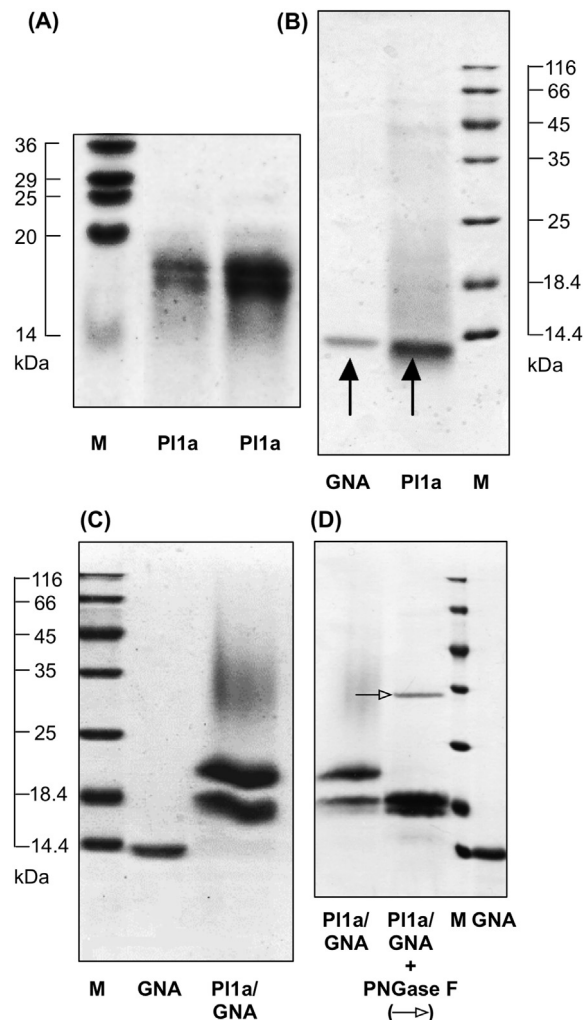

Fig. 2. Characterisation of purified recombinant proteins by SDS-PAGE followed by Coomassie blue staining. (A) P11a toxin separated on “normal” SDS-PAGE; M indicates marker, loadings of P11a are 5 and 10 μ g (B) P11a toxin (5 μ g) separated on SDS-PAGE after denaturation by 6 M urea. (C) P11a/GNA fusion protein (10 μ g). (D) Deglycosylation of P11a/GNA fusion protein using PNGase F (band indicated by open arrowhead).

wt. of 14 kDa (Fig. 2B); the shift in mobility is indicative of gel artefacts, and the single band indicates homogeneity of the product. Further analysis on urea-containing gels gave single bands for P11a, with indicated mol. wts. of approx. 11 kDa without blocking cysteine residues, and approx. 9 kDa after treatment with

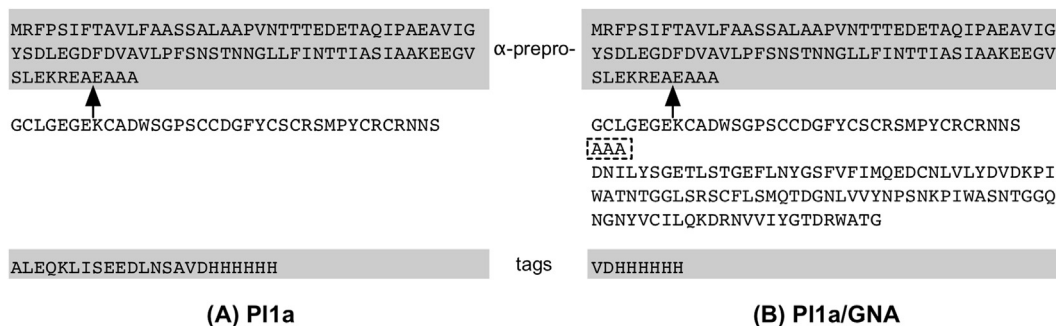

Fig. 1. Sequences of predicted products from expression constructs for P11a toxin (A) and P11a/GNA fusion protein (B). Shaded regions indicate sequence provided by vector; the cleavage point for removal of the yeast α -factor prepro-sequence is indicated by an arrow. Dotted box in (B) indicates the “linker” sequence contributed by the nucleotides used to join the P11a and GNA coding sequences together.

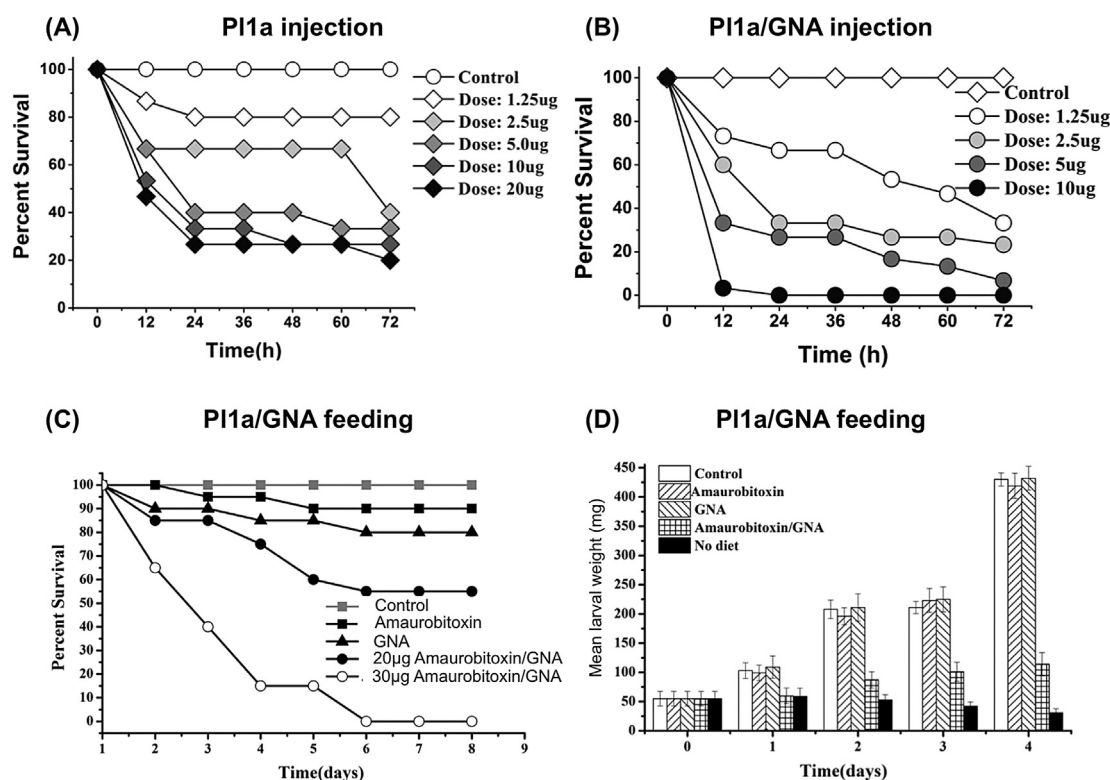

Fig. 3. Bioassays of PI1a and PI1a/GNA against larvae of cabbage moth (*Mamestra brassicae*). (A) Survival of 5th instar larvae after injection of varying amounts of PI1a toxin. (B) Survival of 5th instar larvae after injection of varying amounts of PI1a/GNA fusion protein. (C) Survival of 3rd instar larvae after feeding a single dose of PI1a (Amaurobitoxin; 30 µg), snowdrop lectin (GNA; 30 µg) or PI1a/GNA fusion protein (Amaurobitoxin/GNA; dose as indicated). (D) Growth of 5th instar larvae after feeding a single dose of PI1a (Amaurobitoxin; 30 µg), snowdrop lectin (GNA; 30 µg) or PI1a/GNA fusion protein (Amaurobitoxin/GNA; 30 µg).

iodoacetamide to block cysteine residues (data not presented); these results are diagnostic of incorrect mol. wts. under “normal” conditions due to residual secondary structure and interactions between cysteine residues prior to or during electrophoresis.

The PI1a/GNA fusion protein (Fig. 2C) contained a closely spaced double band of an indicated size of 18 kDa, similar to the expected molecular weight for the fusion protein (17.3 kDa); pretreatment of samples with 6 M urea caused a slight shift in molecular weight to a lower value, and replacement of the double band by a single band, once again suggesting the double band was an artefact (data not presented). The N-terminal sequence of the single band was determined as E-A-A-A-G-, as expected for the fusion protein after removal of the yeast α -factor prepro-region during translation and secretion from *Pichia*. The fusion protein gave two further bands on gel when analysed by SDS-PAGE. It contained a small amount of a band at an indicated molecular weight similar to recombinant GNA (12.7 kDa), which was immunoreactive to anti-GNA antibodies, suggesting a small amount of cleavage of the fusion protein into its components was occurring during production and purification. The ratio of intact PI1a/GNA fusion protein to cleaved GNA was estimated as approx. 30:1 as judged by Coomassie blue staining on SDS-PAGE gels. The PI1a/GNA fusion protein also contained a prominent band at an indicated mol. wt. of approx. 21 kDa, roughly equal in intensity to the band assumed to be PI1a/GNA fusion protein. This was again immunoreactive with anti-GNA antibodies, and had an identical N-terminal sequence to the 18 kDa band. Treatment with the deglycosylating enzyme PNGase F, which cleaves carbohydrate side chains attached to Asn residues through N-glycosidic bonds, removed this band, while the intensity of the “correct” band for the PI1a/GNA fusion protein increased as a result of the treatment (Fig. 2D). This result suggests that the extra band is

due to “core” glycosylation of the fusion protein by *P. pastoris* during synthesis and secretion. GNA contains no potential N-glycosylation sites, but the PI1a toxin sequence contains a potential N-glycosylation site (N-X-S/T) at Asn-35. Quantitation of the PI1a/GNA fusion protein was based on the combined intensity of both the bands representing the glycosylated and non-glycosylated forms. Treatment with PNGase F also removed a “smear” of material of higher molecular weight on SDS-PAGE in PI1a/GNA, which was assumed to represent hyper-glycosylated fusion protein.

3.2. Toxicity of proteins to cabbage moth larvae after injection into the haemolymph

Newly eclosed 5th instar larvae (approx. 45–55 mg in weight; average weight 50 mg) of *M. brassicae* were injected with recombinant PI1a and PI1a/GNA fusion protein to assay biological activity *in vivo*. Larvae injected with PI1a toxin all displayed flaccid paralysis within 1–2 h (little mobility and almost a complete absence of feeding). Most mortality was observed within the first 24 h of the assay (Fig. 3A). After a period of paralysis, some insects showed progressive recovery, and were able to recommence feeding. The effects of PI1a were dose dependent, with mortality after 24 h ranging from 75% at 20 µg toxin/insect to 20% at 1.25 µg toxin/insect. Even at high doses of toxin, complete mortality after 72 h was not observed. From these assays, the estimated LD₅₀ (48 h) for the recombinant PI1a was 4.1 µg/insect, or 8.2 µg/100 mg insect, based on an average larval weight of 50 mg.

The PI1a/GNA fusion protein also caused paralysis and mortality when injected into *M. brassicae* larvae, but was significantly more effective than toxin alone. When insects were injected with 1.25–10 µg fusion protein/insect (equivalent to 0.50–4.0 µg PI1a/insect,

since the molecular weight of recombinant P11a is approx. 0.41 of that of the P11a/GNA fusion protein), significant mortality was observed at all doses, and complete mortality at 24 h was observed at the highest dose (Fig. 3B). As observed for P11a, most mortality occurred within the first 24 h of the assay, and effects of P11a/GNA fusion protein were dose dependent, ranging from 100% mortality at 10 μg fusion protein/insect to 33% mortality at 1.25 μg fusion protein/insect after 24 h. Mortality at this lowest dose of fusion protein increased to 67% after 72 h whereas mortality from injection of 1.25 μg toxin alone/insect did not change from 20% in the period 24–72 h. From these assays, the estimated LD₅₀ (48 h) for the recombinant P11a/GNA fusion protein was 1.4 μg /insect, or 2.8 μg /100 mg insect, based on a mean larval weight of 50 mg. The LD₅₀ estimated for fusion protein is equivalent to 0.57 μg of recombinant P11a toxin per insect, making the fusion protein approx. 7.5 times as active as the recombinant toxin. A similar ratio is obtained by using mortality figures at 72 h. Direct comparisons of mortality produced by identical doses of toxin and fusion protein show that the treatments are different from each other, and from control, at $p < 0.0001$ (ANOVA). In all these assays, no mortality of control injected insects was observed over 72 h.

3.3. Toxicity of proteins to cabbage moth larvae after oral delivery

Newly hatched third instar larvae of *M. brassicae* could consume up to 2 μl droplets of phosphate buffered saline (PBS) containing 10% w/v sucrose if starved for 24 h prior to the experiment. This method was used to deliver recombinant proteins to assay their oral toxicity, by dissolving the protein in the PBS/sucrose solution. Two doses of P11a/GNA fusion protein (20 μg and 30 μg per droplet) and one dose each of P11a (30 μg) and GNA (30 μg) were delivered as experimental treatments. Control larvae were fed PBS/sucrose. Results are shown in Fig. 3C.

Effects on mortality caused by the different treatments were observed over the first 6 days of the assay, with no further effects up to day 8; control survival was 100% over this period. All protein treatments caused reduced survival, but the P11a toxin effect was not significant (survival analysis, log rank test), causing only 10% mortality. The effect of GNA, which caused 20% mortality, was just significant ($p = 0.037$). In contrast, both doses of fusion protein caused highly significant effects on survival ($p < 0.01$). A single 30 μg dose of the P11a/GNA fusion protein led to complete larval mortality after 6 days, with most mortality occurring in the first 4 days after exposure; the 20 μg dose of fusion protein caused 45% mortality. Insects exposed to fusion protein showed partial paralysis, and became lethargic and unresponsive.

Toxic effects were also observed when P11a/GNA fusion protein was fed to larger larvae. Newly eclosed fifth instar larvae fed a single dose of 30 μg of P11a/GNA fusion protein showed 35% mortality over 4 days, whereas control larvae or larvae fed 30 μg doses of P11a or GNA exhibited 100% survival (significantly different; $p < 0.0001$). Surviving insects which had been fed the fusion protein showed strongly retarded growth, increasing their weight only two-fold over 4 days, whereas control insects increased their weight 8-fold (Fig. 3D). Insects, which had been fed P11a or GNA showed no difference in weight gain to the control. The difference in mean larval weight values between fusion-exposed and control, GNA and P11a treatments was highly significant ($P < 0.0001$; ANOVA). The effect of P11a/GNA fusion protein was not the same as starvation, since insects fed no diet showed a weight loss (final weight: initial weight = 0.57) over this period. Instead, oral administration of the fusion protein caused reduced feeding after administration. Insects were transferred back to standard rearing diet, and consumption of diet was measured by decrease in wet weight. The consumption of diet by insects was correlated with

their weight gain; larvae fed diet containing fusion protein consumed approx. 10% of the diet consumed by controls over 5 days, whereas consumption by larvae fed P11a or GNA did not differ significantly from controls (result not presented). The reduced diet consumption is consistent with the observation that insects consuming fusion protein became lethargic and unresponsive, even after transfer back to rearing diet.

3.4. Detection of ingested P11a/GNA in cabbage moth larval tissues after oral delivery

To establish that the P11a/GNA fusion protein was capable of transporting across the gut in *M. brassicae* larvae, haemolymph was extracted from insects fed on diets containing fusion protein and was analysed for the presence of fusion protein by western blotting, using anti-GNA antibodies (Fig. 4A). Insects were starved, given a single 20 μg dose of P11a/GNA in liquid diet, and then returned to normal rearing diet, so the experiment is essentially a “pulse-chase”. The blot confirmed that intact P11a/GNA fusion protein was present in treated insects after 2 h, whereas control insects showed no immunoreactive material. The western blot showed evidence for partial proteolysis of the P11a/GNA fusion protein, with increased levels of a band corresponding in size to GNA being visible on the blots in comparison to purified fusion protein; the sample taken 4 h after feeding the protein shows a “GNA” band comparable in intensity to the fusion protein bands, whereas in the purified protein the “GNA” band is present only at very low intensity compared to the fusion protein bands. The time course of accumulation of fusion protein in the haemolymph gave an unexpected result in that levels of P11a/GNA in the haemolymph increased from the 2 h after feeding sample to 4 h, but the haemolymph sample taken 6 h after feeding contained only very small amounts of P11a/GNA compared to the 4 h sample; this result was reproducible over different feeding experiments. Samples taken at later times (24–72 h) showed fusion protein present in haemolymph at higher levels than at 6 h after feeding.

One destination of P11a/GNA fusion protein delivered to the haemolymph was the central nervous system, the site of action of the toxin. This was shown by dissection of nerve chords from insects after feeding, and analysis by Western blotting (Fig. 4B). Proteins extracted from nerve chords showed immunoreactivity with anti-GNA antibodies, at a level that increased from 2 to 4 h after feeding, and then remained similar for up to 24 h. The immunoreactive bands indicated a higher level of intact fusion protein than the product of proteolysis, GNA. Levels of fusion protein in the nerve chord then declined from 24 h to 72 h after feeding. This accumulation of GNA-based neurotoxic fusion proteins on the nerve chord of insects has been observed previously by direct visualisation using labelled proteins (Fitches et al., 2012). Further examination of tissues from insects fed a “pulse” of P11a/GNA fusion protein confirmed the disappearance of immunoreactive bands from gut and haemolymph 6 h after feeding, and a reappearance of the fusion protein and GNA after 24 h, first in the haemolymph at 24 h after feeding and then in the gut at 48 h and 72 h after feeding (Fig. 4C). These results suggest that the P11a/GNA fusion protein initially binds to nervous tissue, but is subsequently released back into the haemolymph, and subsequently reassociates with gut tissue. In a confirmatory experiment, P11a/GNA fusion protein was injected into the haemolymph of *M. brassicae* larvae at sub-lethal levels, and was detected in different tissues after 4 h (Fig. 4D). P11a/GNA was found associated with gut tissue and Malpighian tubules; a small amount of protein was also present in fat body. No evidence of proteolytic cleavage of this material to GNA was observed, confirming that haemolymph contains low levels of proteolytic activity, in contrast to high levels of protease in

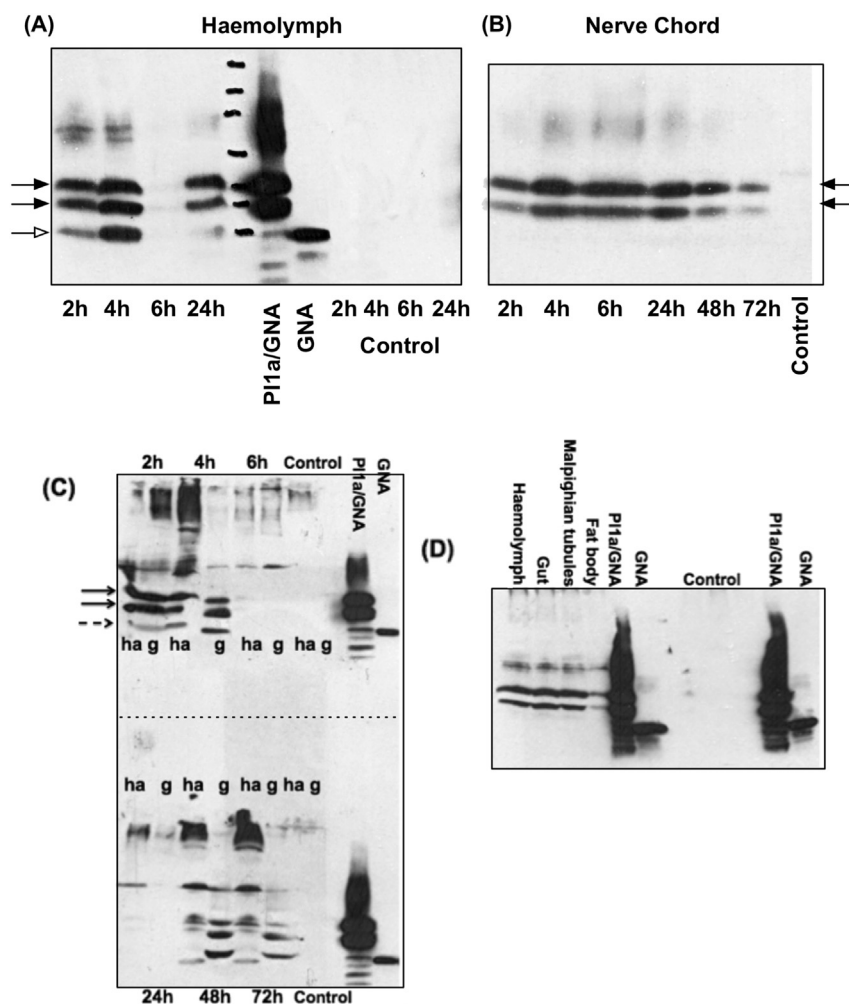

Fig. 4. Transport of PI1a/GNA fusion protein from gut contents to haemolymph, Malpighian tubules, fat body and nerve chord in larvae of cabbage moth (*Mamestra brassicae*). Larvae were injected or fed a single dose of PI1a/GNA fusion protein, and tissues were sampled at the indicated time after feeding. The presence of PI1a/GNA fusion protein was visualised by SDS-PAGE analysis of extracted proteins, followed by western blotting using anti-GNA antibodies. (A) Haemolymph from treated and control insects after feeding PI1a/GNA. (B) Nerve chords from treated and control insects after feeding PI1a/GNA. (C) Gut and haemolymph 2 h, 4 h, 6 h, 20 h, 24 h and 48 h, respectively, after feeding PI1a/GNA; ha, haemolymph; g, gut. (D) Various tissues 4 h after injection of PI1a/GNA to hemolymph.

the gut, where cleavage of the fusion protein was observed after 4 h when PI1a/GNA was delivered orally (Fig. 4A).

3.5. Effects of PI1a and PI1a/GNA fusion protein on housefly

Bioassays using housefly were carried out on adult insects, which could be injected using basic equipment without causing high levels of mortality. These assays showed that both the recombinant PI1a toxin and the PI1a/GNA fusion protein caused paralysis and mortality when injected. Typical results are shown in Fig. 5A and B. Mortality was dose dependent, with most insect deaths taking place in the first 72 h after injection. A dose of 1.0 μg of recombinant PI1a caused 100% mortality in 72 h, and doses ≥ 0.5 μg caused 100% mortality in 144 h. The data gave an estimated LD_{50} (72 h) of 0.18 μg PI1a per insect, or approx. 1.8 μg PI1a per 100 mg insect, based on an average adult weight of approx. 10 mg. The PI1a/GNA fusion protein was significantly more effective than the recombinant toxin, with more rapid mortality at lower doses; at a dose of 0.24 μg per insect, 100% mortality was observed after 24 h. The estimated LD_{50} (72 h) for the fusion protein was 0.045 μg per insect, or approx. 0.45 μg fusion protein per 100 mg insect; this is equivalent to 0.18 μg of PI1a, making the fusion protein approx. 10

times as effective, on a mole-for-mole basis, as the recombinant toxin. The PI1a/GNA fusion protein was also an effective toxin when fed to adult *M. domestica* (Fig. 5C); a 0.25 $\mu\text{g}/\mu\text{l}$ solution caused 100% mortality in 72 h, whereas 0.125 $\mu\text{g}/\mu\text{l}$ solution caused 70% mortality. Flies were completely paralysed approx. 2 h after feeding, and most paralysed insects subsequently died. Higher concentrations of the fusion protein caused lower mortality over 6 days, as the insects would not feed, or fed only very little; the chambers were moist enough to allow insects to survive without feeding.

Attempts to inject larvae of *M. domestica* also showed that both the toxin PI1a and the PI1a/GNA fusion protein were effective toxins, but control survival in these assays was erratic due to damage from the injection. Larvae could not be induced to feed on material containing recombinant proteins.

3.6. Effects of oral delivery of PI1a/GNA fusion protein on pea aphids

Purified recombinant PI1a, PI1a/GNA fusion protein and recombinant GNA were fed to *A. pisum* nymphs by incorporation into artificial diet at a range of concentrations (Fig. 6A). Survival and growth of the insects were monitored. Aphids feeding on 1.0 mg/ml

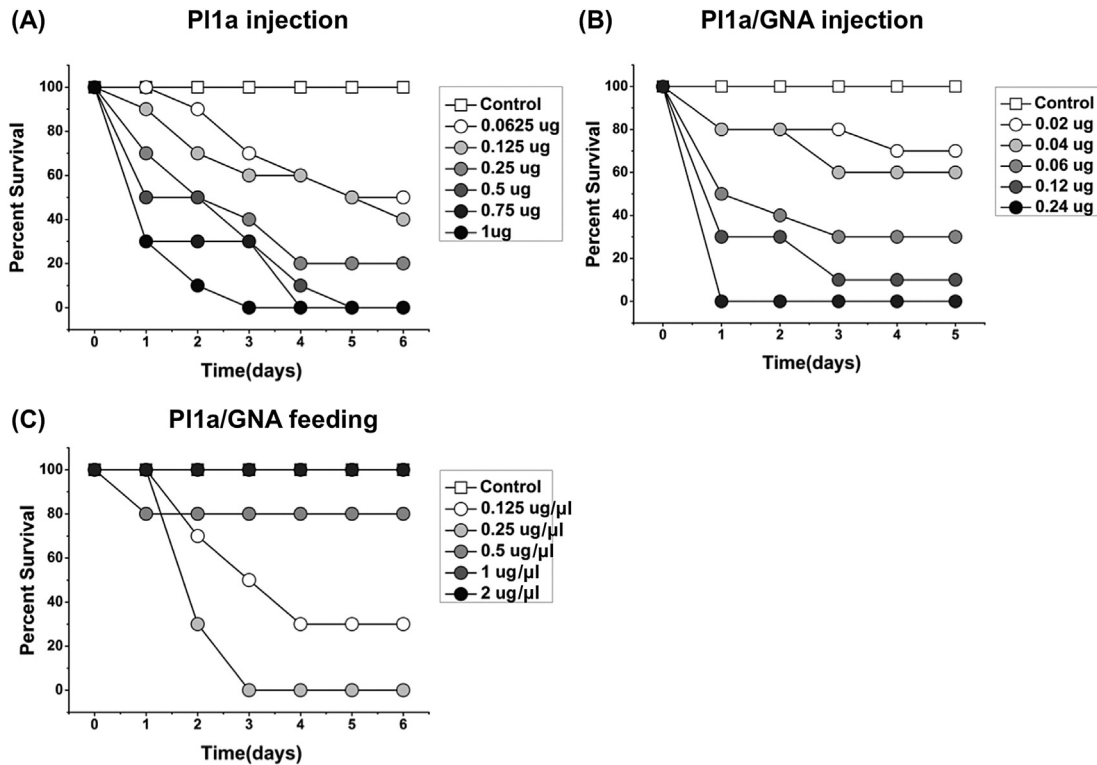

Fig. 5. Bioassays of PI1a and PI1a/GNA against adults of housefly (*Musca domestica*). (A) Survival of adult flies after injection of varying amounts of PI1a toxin. (B) Survival of adult flies after injection of varying amounts of PI1a/GNA fusion protein. (C) Survival of adult flies allowed to feed *ad libitum* on solutions containing PI1a/GNA fusion protein (Amaurobitoxin/GNA; concentration as indicated).

PI1a/GNA fusion protein showed 100% mortality in 3 days of feeding, which was significantly different to negative controls, whereas aphids feeding on diet containing 0.24 mg/ml PI1a or 0.76 mg/ml GNA showed only 53.3% or 33.3% mortality in 7 days of feeding compared with 1.0 mg/ml PI1a/GNA. Moreover, feeding a mixture of PI1a (0.24 mg/ml) and GNA (0.76 mg/ml), which was equivalent to 1 mg/ml PI1a/GNA fusion protein in the content, showed 83.3% mortality in 7 days of feeding whereas 1 mg/ml PI1a/GNA caused 100% mortality in 3 days. The fusion protein survival curve was significantly different to controls and other treatments ($p < 0.001$). The treatments also decreased in aphid growth by approx. 60%, which was significant compared to controls, but differences between treatments were not significant (data not presented).

Feeding PI1a/GNA at different concentrations from 0.25 mg/ml to 1 mg/ml showed a dose dependent effect on *A. pisum* survival (data not presented). After 7 days of feeding, 1.0 mg/ml PI1a/GNA caused 100% mortality whereas the lowest concentration of PI1a/GNA, 0.25 mg/ml, produced approx. 10% mortality. From 0.5 mg/ml to 1 mg/ml, all survival curves for PI1a/GNA were significantly different to negative controls, and aphid growth was significantly reduced. However, the size of 0.25 mg/ml PI1a/GNA-fed aphids was not significantly different to control aphids, suggesting that the aphids were capable of overcoming the growth retardation effects of 0.25 mg/ml PI1a/GNA.

To demonstrate binding of proteins to the aphid gut surface, recombinant PI1a, GNA and PI1a/GNA fusion protein were labelled by conjugation with fluorescein, and fed in diet to aphids at a sub-lethal concentration (0.8 mg/ml PI1a, 1 mg/ml GNA and 0.64 mg/ml PI1a/GNA) for 24 h. The label was then "chased" by allowing aphids to feed on control diet for 24 h and 48 h. Labelled proteins were detected in whole insects by fluorescence microscopy, and were readily detectable in insects with no chase after feeding. Results are

presented in Fig. 6B. Fluorescein, used as a negative control (Fig. 6B, panel 24), was eliminated completely from the aphid gut after 48 h chase, whereas fluorescein-labelled GNA, used as a positive control, was still present in the gut after 48 h chase (Fig. 6B, panel 12). As expected, the labelled PI1a/GNA fusion protein also persisted in the midgut region of aphids, and was detectable even after 48 h chase (Fig. 6B, panel 6). Surprisingly, labelled recombinant PI1a could also bind to the gut (Fig. 6B, panels 16–17), and was detectable after 24 h chase, although the level of binding after 48 h chase decreased to undetectable (Fig. 6B panel 18), in contrast to labelled GNA and PI1a/GNA, which were detectable after 48 h chase. These results showed that although recombinant PI1a, GNA, and PI1a/GNA could all bind to the aphid gut, recombinant PI1a was most readily removed, suggesting weaker binding.

4. Discussion

The δ -amaurobitoxin PI1a was selected as a possible component for biopesticidal fusion proteins for reasons described earlier (insecticidal activity and insect-specificity), but also because it is effective against a different target than previous insecticidal neurotoxins used in lectin-based fusion proteins; Sf11, from the spider *Segestria florentina* (Fitches et al., 2004) has an unknown target, ButaIT from the scorpion *Mesobuthus tamulus* (Trung et al., 2006) is assumed to target chloride channels, and Hv1a, from the spider *Hadronyche versuta* (Fitches et al., 2012) targets calcium channels. As a toxin which targets the insect sodium channel (Corzo et al., 2005), PI1a therefore represents a novel type of insecticidal component. The insect sodium channel is a major target for conventional pesticides, such as pyrethroids, and inactivation leads to rapid paralysis and death; exploitation of this target in the insect is thus based on established practice.

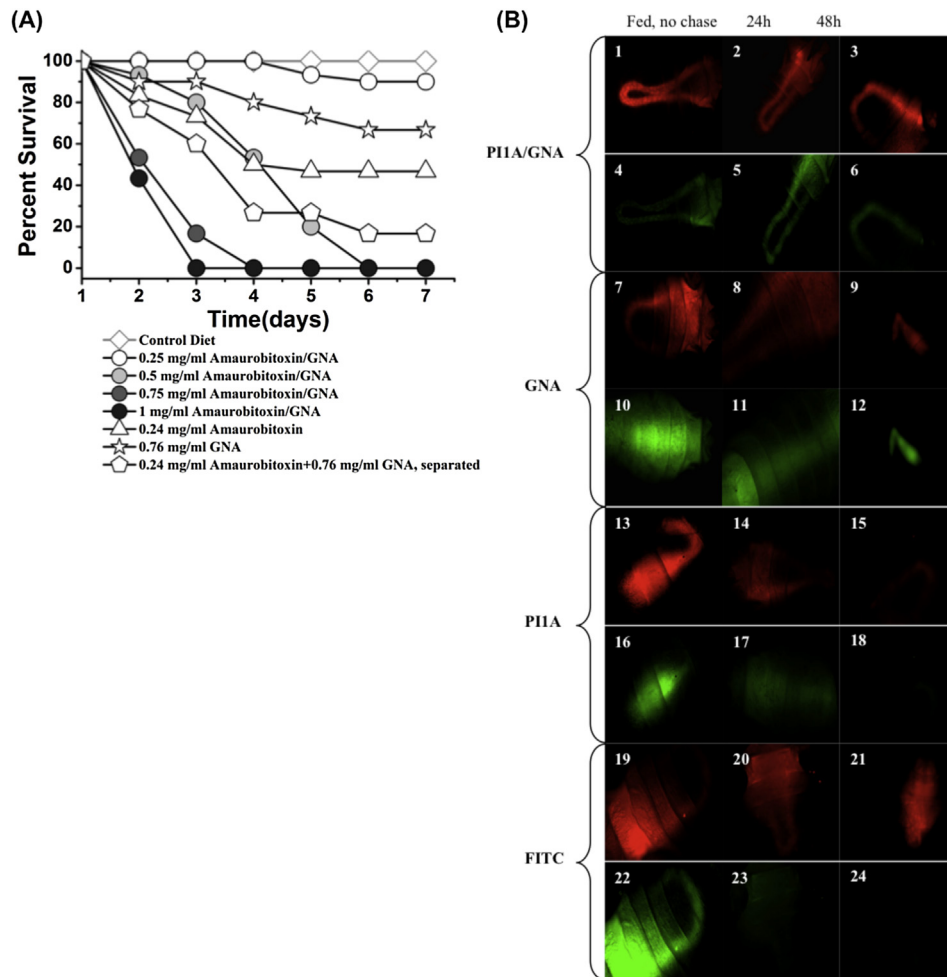

Fig. 6. Bioassays of P11a and P11a/GNA against nymphs of pea aphid (*Acyrtosiphon pisum*). (A) Survival of aphids on diets containing P11a (Amaurobitoxin), snowdrop lectin (GNA) or P11a/GNA fusion protein (Amaurobitoxin/GNA) at concentrations as indicated. (B) Feed-chase experiment to show binding of proteins to aphid gut. Diets containing recombinant proteins labelled with FITC were fed to aphids for 24 h. Subsequently the label was “chased” with control diet for times as indicated. Red fluorescence indicates the aphid gut, green fluorescence indicates labelled proteins. (For interpretation of the references to colour in this figure legend, the reader is referred to the web version of this article.)

P11a represents a distinct type of sodium channel inactivating toxin (Ferrat et al., 2005). Although most spider toxins just slow NaCh inactivation in a fashion similar to that of receptor site 3 modifiers, δ -amaurobitoxins are similar to scorpion β -toxins in binding with high affinity to the topologically distinct receptor site 4, which involves domain II in insect and mammalian NaChs (Cestele et al., 1998). δ -amaurobitoxins and scorpion β -toxins show some similarity in their bioactive surfaces and ability to compete for an identical receptor (site 4) on voltage-gated NaChs, though they have developed from different ancestors. The δ -amaurobitoxins like P11a recognize insect voltage-gated sodium channels by multiple sequence features, including a β -sheet secondary structure, loops I, IV of the toxin and the specific dipolar moment orientation (Ferrat et al., 2005). The roles of different amino acid residues in determining binding and toxicity have been investigated by alanine scanning mutagenesis; Asp-19 may be causal in toxicity, since substitution of this residue by Ala affected toxicity to lepidopteran larvae, but not binding to the sodium channel (Corzo et al., 2005). These results can be exploited to manipulate the toxin component of a fusion protein if necessary to modify activity or specificity. Data for the insecticidal activity of P11a (Arachnoserver) suggests that it shows a higher LD₅₀ on a mole/g basis than that reported for Hv1a, the toxin component of the atracotoxin/GNA fusion protein described by Fitches et al. (2012).

The yeast *Pichia pastoris* was selected as expression host for production of recombinant P11a and P11a/GNA fusion proteins on the basis of previous work showing that small proteins containing multiple disulphide bonds can be produced in active form in this organism (Cereghino and Cregg, 2000). Efficient secretion of expressed proteins into the culture medium, directed by the yeast α -factor prepro-sequence incorporated into the expression vector pGAPZ α , is an additional advantage in that purification of the recombinant protein is simplified by having relatively few contaminating *Pichia* proteins present in the culture medium, and not having to lyse cells to obtain the product. Proteolysis of fusion proteins produced in *P. pastoris* during secretion, or in the culture medium, or during purification, has been a significant problem with previous toxin-GNA fusions (Fitches et al., 2004), resulting in the final product containing significant amounts (up to 50%) of GNA without attached toxin. However, the P11a/GNA fusion protein is relatively resistant to proteolysis, and the purified product contains only small amounts of free GNA.

P. pastoris has an efficient N-glycosylation system for proteins which pass through the ER, although in most cases core glycosylation with a branched oligomannose structure is only elaborated by addition of extra mannose residues (Bretthauer and Castellino, 1999). Both the recombinant P11a toxin and the P11a/GNA fusion protein contain an N-glycosylation site, corresponding to the

sequence –NNS– at the C-terminus of the mature toxin. However, only the fusion protein shows evidence of glycosylation at this site. Utilisation of an N-glycosylation site requires the amino acid residues to be accessible to the glycosylating enzyme(s), and not all sites are used. The difference in glycosylation properties of the recombinant toxin and fusion protein is evidence for differences in folding and accessibility in this region of the toxin.

Both the recombinant toxin alone and the fusion protein, show insecticidal activity on injection into lepidopteran and dipteran insects, with the expected symptoms of paralysis and mortality. However, in both sets of assays, the fusion protein has an activity at least 6-fold higher on a molar basis than the recombinant toxin. There is some evidence from injection bioassays to suggest that the recombinant toxin has lower insecticidal activity than expected. The LD₅₀ for recombinant toxin alone observed in the injection bioassays against *M. brassicae* larvae, 4.1 µg/insect, or 12 nmoles/g insect is approx. 5-fold higher than the quoted literature value for purified and synthetic P11a toxins of 2.35 nmoles/g insect for larvae of *S. litura* [LD₅₀ (48 h) = 9.5 µg/g insect; Corzo et al., 2000]. In contrast, the LD₅₀ for the recombinant fusion protein is lower than this literature value for purified toxin when expressed on a molar basis; 1.4 µg/insect for P11a/GNA is equivalent to 1.6 nmoles/g insect. If it is assumed that larvae of the two lepidopteran species have similar susceptibility to the P11a, then these data would suggest that the toxin in the P11a/GNA fusion protein has the expected biological activity, whereas the recombinant toxin alone does not. Two possibilities can be advanced to explain this observation. First, fusion to GNA could improve toxin folding during production as a recombinant protein, leading to a product with more biological activity. Secondly, the carbohydrate-binding activity of GNA enables it to act as an anchor to bind toxin to nerve tissue and increase its local concentration, leading to a higher effective dose. The evidence from western blotting showing high levels of fusion protein associated with nerve chord tissue supports this hypothesis. The results presented here, in agreement with previous data (Fitches et al., 2012), show that fusion to GNA can enhance recombinant toxin biological activity.

The droplet feeding assays provide clear evidence of the oral toxicity of the P11a/GNA fusion protein towards lepidopteran and dipteran insects. In the assays with *M. brassicae* larvae no significant toxicity of the toxin alone was observed, and only marginal effects from the GNA carrier, in agreement with previous assays in which GNA was fed to larvae of tomato moth, *Lacanobia oleracea* (Fitches et al., 2001). Only the fusion protein was tested against *M. domestica* adults, but previous results have shown that GNA alone has only limited toxicity at high doses (Fitches et al., 2009). The resistance to proteolysis shown by the P11a/GNA fusion protein, observed during production and purification, is likely to be a factor in its oral toxicity; a high proportion of the GNA transported across the gut will be fused to the toxin, resulting in efficient transport of toxin into the haemolymph (free toxin does not transport, since orally delivered toxin is ineffective). However, some cleavage of fusion protein to release GNA does occur in the larval gut, since significant levels of free GNA are subsequently present in the haemolymph, and fusion protein injected into the haemolymph is stable. High levels of proteolytic activity are present in the larval gut of *M. brassicae* (Chougule et al., 2008).

The western blotting experiments show transport of intact fusion protein into the haemolymph, and accumulation on nervous tissue; after feeding a single dose, fusion protein initially accumulates in the haemolymph, and then clears after 6 h. The subsequent reappearance of fusion protein in haemolymph after 24 h is most likely to be due to release from nervous tissue that is being degraded, as a result of partial or complete inactivation due to the toxin. Although the initial transport of fusion protein is from gut to

haemolymph, interestingly, retrograde transport of fusion protein from haemolymph to gut can also occur, suggesting that transport across the gut is a passive, rather than an active process.

Whereas the P11a/GNA fusion protein shows effective oral toxicity in the lepidopteran and dipteran insects tested while its component proteins either have no toxicity, or very limited toxicity, the situation is less clear cut in aphids. The fusion protein was a more effective toxin than either of its components, or a mixture of its components, but both components of the fusion showed significant oral toxicity. For GNA, this is in agreement with previous reports of oral toxicity to aphids and other hemipteran insects. The oral toxicity of the P11a toxin itself is more surprising, and the mechanism through which the toxin is able to access sites of action when fed to aphids remains obscure. Further experiments will be necessary to show whether the binding of toxin to the gut surface in aphids leads to transport to the haemolymph (as is the case for GNA) or whether the toxin remains in the gut contents. In this example, fusion to GNA enhances the oral toxicity of P11a rather than conferring novel oral toxicity.

The amaurobitoxin-lectin fusion protein described in this paper is a promising candidate for development as a biopesticide with activity against lepidopteran and dipteran pests; it has an approx. 10-fold lower LD₅₀ towards *M. brassicae* larvae by injection than the Hv1a/GNA fusion protein described by Fitches et al. (2012), and caused mortality after droplet feeding a single dose to 5th instar larvae of *M. brassicae*, whereas a greater dose of Hv1a/GNA fusion protein only caused growth retardation. It is also approx. 8-fold more active towards *M. domestica* adults than the ButaIT/GNA scorpion toxin fusion protein described by Fitches et al. (2009), where a 1.0 µg/µl solution caused only 75% mortality after 72 h, in contrast to 70% mortality produced by a 0.125 µg/µl solution of P11a/GNA. Further trials of insecticidal activity and selectivity will be necessary to ensure that the fusion protein could be used safely in agricultural applications.

Acknowledgements

Work described in this paper has been carried out with funding from the Technology Strategy Board (TSB; TS/I000690/1), and from the BBSRC China Partnership Scheme (BB/G530409), which is acknowledged with gratitude. SY received support for his Ph.D. programme jointly from the China Scholarship Scheme, and a Durham University Doctoral Studentship; this funding is also gratefully acknowledged.

References

- Baumgartner, P., Harper, K., Raemaekers, R.J.M., Durieux, A., Gatehouse, A.M.R., Davies, H.V., Taylor, M.A., 2004. Large-scale production and purification of recombinant *Galanthus nivalis* agglutinin (GNA) expressed in the methylotrophic yeast *Pichia pastoris*. *Biotechnol. Lett.* 25, 1281–1285.
- Bown, D.P., Wilkinson, H.S., Gatehouse, J.A., 1997. Differentially regulated inhibitor-sensitive and insensitive protease genes from the phytophagous insect pest, *Helicoverpa armigera*, are members of complex multigene families. *Insect Biochem. Mol. Biol.* 27, 625–638.
- Bretthauer, R.K., Castellino, F.J., 1999. Glycosylation of *Pichia pastoris*-derived proteins. *Biotechnol. Appl. Biochem.* 30, 193–200.
- Casida, J.E., Quistad, G.B., 1998. Golden age of insecticide research: past, present, or future? *Annu. Rev. Entomol.* 43, 1–16.
- Cereghino, J.L., Cregg, J.M., 2000. Heterologous protein expression in the methylotrophic yeast *Pichia pastoris*. *FEMS Microbiol. Rev.* 24, 45–66.
- Cestele, S., Qu, Y., Rogers, J.C., Rochat, H., Scheuer, T., Catterall, W.A., 1998. Voltage sensor-trapping: enhanced activation of sodium channels by beta-scorpion toxin bound to the S3–S4 loop in domain II. *Neuron* 21, 919–931.
- Chougule, N.P., Doyle, E., Fitches, E., Gatehouse, J.A., 2008. Biochemical characterization of midgut digestive proteases from *Mamestra brassicae* (cabbage moth; Lepidoptera: Noctuidae) and effect of soybean Kunitz inhibitor (SKTI) in feeding assays. *J. Insect Physiol.* 54, 563–572.
- Corzo, G., Escoubas, P., Stankiewicz, M., Pelhate, M., Kristensen, C.P., Nakajima, T., 2000. Isolation, synthesis and pharmacological characterization of δ-palutoxins

- IT, novel insecticidal toxins from the spider *Paracoelotes luctuosus* (Amaurobiidae). *Eur. J. Biochem.* 267, 5783–5795.
- Corzo, G., Escoubas, P., Villegas, E., Karbat, I., Gordon, D., Gurevitz, M., Nakajima, T., Gilles, N., 2005. A spider toxin that induces a typical effect of scorpion alpha-toxins but competes with beta-toxins on binding to insect sodium channels. *Biochemistry* 44, 1542–1549.
- Denholm, I., Rowland, M.W., 1992. Tactics for managing pesticide resistance in arthropods – theory and practice. *Annu. Rev. Entomol.* 37, 91–112.
- Desneux, N., Decourtye, A., Delpuech, J.M., 2007. The sublethal effects of pesticides on beneficial arthropods. *Annu. Rev. Entomol.* 52, 81–106.
- Ferrat, G., Bosmans, F., Tytgat, J., Pimentel, C., Chagot, B., Gilles, N., Nakajima, T., Darbon, H., Corzo, G., 2005. Solution structure of two insect-specific spider toxins and their pharmacological interaction with the insect voltage-gated Na⁺ channel. *Proteins* 59, 368–379.
- Fitches, E., Gatehouse, J.A., 1998. A comparison of the short and long term effects of insecticidal lectins on the activities of soluble and brush border enzymes of tomato moth larvae (*Lacanobia oleracea*). *J. Insect Physiol.* 44, 1213–1224.
- Fitches, E., Woodhouse, S.D., Edwards, J.P., Gatehouse, J.A., 2001. In vitro and in vivo binding of snowdrop (*Galanthus nivalis* agglutinin; GNA) and jackbean (*Canavalia ensiformis*; Con A) lectins within tomato moth (*Lacanobia oleracea*) larvae; mechanisms of insecticidal action. *J. Insect Physiol.* 47, 777–787.
- Fitches, E., Audsley, N., Gatehouse, J.A., Edwards, J.P., 2002. Fusion proteins containing neuropeptides as novel insect control agents: snowdrop lectin delivers fused allatostatin to insect haemolymph following oral ingestion. *Insect Biochem. Mol. Biol.* 32, 1653–1661.
- Fitches, E., Edwards, M.G., Mee, C., Grishin, E., Gatehouse, A.M., Edwards, J.P., Gatehouse, J.A., 2004. Fusion proteins containing insect-specific toxins as pest control agents: snowdrop lectin delivers fused insecticidal spider venom toxin to insect haemolymph following oral ingestion. *J. Insect Physiol.* 50, 61–71.
- Fitches, E., Bell, H.A., Powell, M., Back, E., Sargiotti, C., Weaver, R.J., Gatehouse, J.A., 2009. Insecticidal activity of scorpion toxin (ButaIT) and snowdrop lectin (GNA) containing fusion proteins towards pest species of different orders. *Pest Manage. Sci.* 66, 74–83.
- Fitches, E.C., Pyati, P., King, G.F., Gatehouse, J.A., 2012. Fusion to snowdrop lectin magnifies the oral activity of insecticidal ω -hexatoxin-Hv1a peptide by enabling its delivery to the central nervous system. *PLoS One* 7, e39389.
- Prosser, W.A., Douglas, A.E., 1992. A test of the hypotheses that nitrogen is upgraded and recycled in an aphid (*Acyrtosiphon pisum*) symbiosis. *J. Insect Physiol.* 38, 93–99.
- Rash, L.D., Hodgson, W.C., 2002. Review: pharmacology and biochemistry of spider venoms. *Toxicon* 40, 225–254.
- Sambrook, J., Russell, D.W., 2001. *Molecular Cloning: a Laboratory Manual*. Cold Spring Harbor Laboratory Press, Cold Spring Harbor, NY.
- Trung, N.P., Fitches, E., Gatehouse, J.A., 2006. A fusion protein containing a lepidopteran-specific toxin from the South Indian red scorpion (*Mesobuthus tamulus*) and snowdrop lectin shows oral toxicity to target insects. *BMC Biotechnol.* 6, 18.
- Vassilevski, A.A., Kozlov, S.A., Grishin, E.V., 2009. Molecular diversity of spider venom. *Biochem. (Mosc)* 74, 1505–1534.
- Whetstone, P.A., Hammock, B.D., 2007. Delivery methods for peptide and protein toxins in insect control. *Toxicon* 49, 576–596.

Effect of insecticidal fusion proteins containing spider toxins targeting sodium and calcium ion channels on pyrethroid-resistant strains of peach-potato aphid (*Myzus persicae*)

Sheng Yang,^a Elaine Fitches,^b Prashant Pyati^a and John A Gatehouse^{a*}

Abstract

BACKGROUND: The recombinant fusion proteins PI1a/GNA and Hv1a/GNA contain the spider venom peptides δ -amaurobitoxin-PI1a or ω -hexatoxin-Hv1a respectively, linked to snowdrop lectin (GNA). PI1a targets receptor site 4 of insect voltage-gated sodium channels (NaCh), while Hv1a targets voltage-gated calcium channels. Insecticide-resistant strains of peach-potato aphid (*Myzus persicae*) contain mutations in NaCh. The pyrethroid-resistant *kdr* (794J) and *super-kdr* (UKO) strains contain mutations at residues L1014 and M918 in the channel α -subunit respectively, while the *kdr* + *super-kdr* strain (4824J), insensitive to pyrethroids, contains mutations at both L1014 and M918.

RESULTS: PI1a/GNA and Hv1a/GNA fusion proteins have estimated LC₅₀ values of 0.35 and 0.19 mg mL⁻¹ when fed to wild-type *M. persicae*. For insecticide-resistant aphids, LC₅₀ for the PI1a/GNA fusion protein increased by 2–6-fold, correlating with pyrethroid resistance (wild type < *kdr* < *super-kdr* < *kdr* + *super-kdr* strains). In contrast, LC₅₀ for the Hv1a/GNA fusion protein showed limited correlation with pyrethroid resistance.

CONCLUSION: Mutations in the sodium channel in pyrethroid-resistant aphids also protect against a fusion protein containing a sodium-channel-specific toxin, in spite of differences in ligand–channel interactions, but do not confer resistance to a fusion protein targeting calcium channels. The use of fusion proteins with differing targets could play a role in managing pesticide resistance.

© 2014 Society of Chemical Industry

Keywords: biopesticide; insecticide resistance; Homoptera/Hemiptera; voltage-gated ion channels; fitness cost

1 INTRODUCTION

The peach-potato aphid, *Myzus persicae* (Sulzer) (Hemiptera: Aphididae), is a serious worldwide insect pest of agricultural and horticultural crops, which, through its sap-sucking feeding habit, can transmit viral diseases.¹ Pyrethroids are a major class of insecticides used to control this pest, but populations of *M. persicae* can rapidly develop resistance to pyrethroids, leading to increased economic loss to agricultural producers.² Pyrethroids target the insect voltage-gated sodium channel, a large transmembrane protein composed of a single 260 kDa polypeptide (the α -subunit), which contains four repeating and homologous domains (I–IV), with each domain being constituted by six hydrophobic transmembrane segments (S1–S6).³ The insect sodium channel is similar in structure to the vertebrate sodium channel, containing different allosterically coupled receptor-binding sites for various neurotoxicants, but the two types of channel are distinguishable in the pharmacology. Therefore, insecticides such as pyrethroids can be specific for insect sodium channels, showing no effect on mammals.^{4,5}

Pyrethroids are hydrophobic compounds, and are thought to bind to the lipid-exposed interface formed by helices IIS6, IIS5, linker helix IIS4–IIS5 and the IS4–IS5 linker,^{6,7} affecting the

functional properties of the sodium channel. By preventing closure of the sodium channel, pyrethroids cause paralysis in insects.⁵ However, with the extensive use of pyrethroids, many insects have developed resistance to these insecticides, associated with mutations in the sodium channel. The pyrethroid resistance shown by *M. persicae* is typical of that seen in many species.^{8–10} In aphids carrying the *kdr* mutation there is a leucine-to-phenylalanine substitution (L1014F) within segment 6 of domain II (IIS6) of the channel protein,¹¹ which confers an intermediate level of resistance to pyrethroids. In aphids carrying the *super-kdr* site mutation, there is an additional methionine-to-threonine substitution (M918T) in the linker between segment 4 and segment 5 of domain II (IIS4–IIS5 linker) of the sodium channel protein,⁸ which makes *M. persicae* highly resistant to pyrethroids. Data presented by Eleftherianos *et al.*¹ show that, whereas the EC₅₀ for

* Correspondence to: John A Gatehouse, School of Biological and Biomedical Sciences, Durham University, South Road, Durham DH1 3LE, UK, E-mail: J.A.Gatehouse@durham.ac.uk

^a School of Biological and Biomedical Sciences, Durham University, Durham, UK

^b Food and Environment Research Agency (Fera), Sand Hutton, York, UK

a typical pyrethroid insecticide on wild-type *M. persicae* is in the range 0.5–2.8 ppm, a homozygous *kdr* mutation increases the EC₅₀ by 20–75-fold, and a heterozygous *kdr* + *super-kdr* mutation increases resistance by 100–500-fold. The emergence of insecticide resistance is one factor driving a need for new specific environmentally benign pesticides, which could be used in strategies to manage resistance to chemicals like pyrethroids more effectively.

Spider toxin peptides have been suggested as environmentally friendly biopesticides. Toxins have been isolated from a range of arachnids, and most are small cysteine-rich proteins that principally target neuronal ion channels to cause paralysis of the spider's prey.^{4,12} Toxins can be selected that are insect specific and have no effects on members of other taxons. This advantage would make them ideal candidates for use in pest control and crop protection, if a suitable delivery system that would get around the problem of toxicity being dependent on injection into the body fluid of the pest could be devised.¹³ Recombinant fusion proteins, containing insecticidal peptides or proteins fused to a 'carrier' protein are a method that gives oral toxicity to neuroactive toxins.^{14,15} The carrier protein transports the insecticidal peptide or protein across the insect gut epithelium into the haemolymph, from which it can access the central nervous system (CNS), which is the site of action. The mannose-specific lectin from snowdrop, *Galanthus nivalis* agglutinin (GNA), which has been shown to transport peptides into the insect haemolymph, is currently being used for making fusion proteins. Fusion proteins containing GNA as a carrier possess good stability towards proteolysis in the insect gut and high toxicity.¹⁶

δ -Amaurobitoxins, or δ -palutoxins, from the spider *Pireneitega luctuosus*, are a family of four similar 36–37 residue peptides containing eight cysteine residues that are disulfide linked to form a cysteine knot motif. PI1a is specific for insect sodium channels, causing paralysis, and has no adverse effects when injected into mice.¹⁷ The toxin acts by binding to receptor site 4 in the sodium channel protein, which involves the extracellular loops of S1–S2 and S3–S4 of domain II.¹⁸ It affects the functional properties of the sodium channel α -subunit by shifting the voltage dependence of activation, resulting in paralysis; the effect is similar to that produced by pyrethroids.⁵ A PI1a/GNA fusion protein has been shown to be an effective oral insecticide towards insects of different orders, including aphids.¹⁹

Hv1a is a family member of insecticidal neurotoxins, which possess 36–37 residues, from the Australian funnel web spider *Hadronyche versuta*.²⁰ Hv1a arrests insect voltage-gated calcium channels and has no negative effects on mammals.^{21–23} Hv1a contains three disulfide bonds which shape an inhibitor cystine knot motif, which confers chemical and thermal stability and resistance to proteases.^{24,25} The highly conserved C-terminal β hairpin of Hv1a contains the key residues for insecticidal activity.²⁰ An Hv1a/GNA fusion protein has been described previously, and its oral toxicity towards insects has been demonstrated.¹⁶

The present paper compares the toxicity of PI1a/GNA and Hv1a/GNA fusion proteins towards wild-type and pyrethroid-resistant strains of *M. persicae*, and shows that, although the toxicity of PI1a/GNA is reduced by the *kdr* and *super-kdr* mutations in the sodium channel, it retains some activity. However, the mutations confer no resistance to Hv1a/GNA targeting calcium channels. This residual high insecticidal activity makes Hv1a/GNA a potential biopesticide for controlling pyrethroid-resistant aphids.

2 MATERIALS AND METHODS

2.1 Materials

Chemicals and reagents were of analytical grade and were supplied by Sigma or BDH Chemical Company unless stated otherwise. Restriction enzymes and other molecular biology reagents were supplied by Fermentas. A double-stranded DNA incorporating a sequence encoding the mature PI1a toxin (P83256), with codons optimised for expression in *Pichia pastoris*, was designed by the authors, synthesised and supplied by ShineGene Molecular Biotech, Inc. (Shanghai, China; <http://www.synthesigene.com/>). Other oligonucleotides required for cloning were supplied by Sigma Chemical Co. Recombinant snowdrop lectin was produced by the authors by expression in *Pichia pastoris*, as described by Baumgartner *et al.*²⁶

The mutant strains of peach-potato aphid, *Myzus persicae* (Sulzer) (Hemiptera: Aphididae), were kindly provided by Prof. Linda M Field (Department of Biological Chemistry and Crop Protection, Rothamsted Research, UK). Strain 4106A has no mutation (*wild type*). Strain 794J is homozygous for the mutation L1014F (*kdr*) and is resistant to pyrethroids. Strain UKO is homozygous for the mutation M918L (*super-kdr*) and shows enhanced resistance to pyrethroids. 4824J is homozygous for L1014F (*kdr*) and M918T (*super-kdr*) and shows immunity to pyrethroids.¹ Aphids were cultured on fresh Chinese leaf under conditions of 12:8 h light:dark, 18 °C and 70% relative humidity.

2.2 Production of PI1a/GNA and Hv1a/GNA fusion proteins

Assembly of expression constructs encoding PI1a, PI1a/GNA and GNA and expression of the recombinant proteins in the yeast *Pichia pastoris* have been described elsewhere.¹⁹ The fusion proteins, which contained C-terminal (His)₆ tags, were purified by metal affinity chromatography, dialysed and lyophilised as previously described.^{14–16} Expression constructs for Hv1a and Hv1a/GNA and production of recombinant proteins have also been described previously;¹⁶ the constructs used to express Hv1a and Hv1a/GNA for this paper were modified by inclusion of a predicted pro-region for the toxin.²⁷ Other recombinant proteins were produced as previously described.¹⁵ Purified proteins were analysed by SDS-PAGE for quantitation by comparison with standards run on the same gel; proteins were also quantitated by using the BCA assay, and by absorbance.

2.3 Bioassays on peach-potato aphid

Bioassay of aphids using liquid artificial diet was carried out as described by Prosser and Douglas.²⁸ Adult aphids were transferred to control liquid diet and acclimatised for 24 h, and then neonate nymphs produced over the following 24 h were transferred to experimental diets and allowed to develop to adult stage (8–9 days). Twenty individuals per treatment were used to perform the bioassays. Each assay was repeated 3 times. Mortality was observed daily, and assays were continued until control aphids started to produce nymphs. Nymphs were not counted, but the presence or absence of progeny was recorded. Effects of treatments on aphid growth were assessed by using Image J Software to measure insect length.

2.4 Statistical analysis

Mortality data were analysed using survival curves, with a Kaplan–Meier test to evaluate significance of differences (Origin 8.5 software). ANOVA analysis (with Bonferroni–Dunn *post*

hoc tests) was carried out to determine any significant differences between treatments in size parameters measured. Differences between treatments were considered significant at a probability level $P < 0.05$. LC_{50} values for different treatments were estimated by taking survival data for diets containing different concentrations of fusion proteins (over a range of 0.125–2.0 mg mL⁻¹) and fitting data points to a sigmoidal dose–response curve by non-linear regression (Prism v.5 software).

3 RESULTS

3.1 Toxicity of separate components of fusion proteins

Effects of toxins and GNA components of insecticidal fusion proteins on the strains of peach-potato aphids (794J, UKO, 4824J and 4106A) were determined by bioassays in which components were fed separately in liquid diet from neonate nymphs. Concentrations were chosen to be equivalent to 1 mg mL⁻¹ of fusion protein. Results are shown in Fig. 1. None of the treatments caused more than 30% mortality over a 7 day period of development, against a background of no mortality in aphids on control diet; survival analysis showed that most differences to control were not significant (effect on survival by difference in survival curve; $P > 0.05$). The GNA carrier protein showed significant effects on *M. persicae* survival (difference in survival curve; $P < 0.05$), in agreement with previous reports that this protein is weakly insecticidal towards aphids;²⁹ it also caused growth retardation in the bioassays to begin with, although aphids were able to recover from the effects and produced nymphs. There were no significant differences in the effects of GNA between aphid strains. At the concentrations used, the Hv1a toxin showed significant effects on *M. persicae* (30% mortality after 7 days; effect on survival by difference in survival curve; $P < 0.05$), whereas P11a did not have a significant effect, although both toxins have been shown previously to have some effect on aphids when fed on diet. Once again, no significant differences between aphid strains were observed in these assays. These data confirm previous observations that the separate components of insecticidal fusion proteins have only limited insecticidal effects when fed to *M. persicae*.

3.2 Toxicity of P11a/GNA recombinant fusion protein

Purified recombinant P11a/GNA fusion protein was fed to each *M. persicae* strain at a range of concentrations, and survival curves were plotted for all treatments. Results for feeding at 1 mg mL⁻¹ are shown in Fig 2A. At this level, the fusion protein caused complete mortality to strain 4106A (*wild type*) after 7 days, but not in any of the insecticide resistant strains, even after 11 days. The survival curves show significant differences between strains 4106A (*wild type*), 794 J (*kdr*) and UKO (*super-kdr*) and the controls not fed fusion protein ($\geq 90\%$ survival) ($P < 0.05$), confirming the insecticidal activity of the treatment. However, the survival curve for strain 4824 J (*kdr + super-kdr*: 90% survival over the assay) fed P11a/GNA at 1 mg mL⁻¹ is not significantly different to that for aphids fed control diet containing no fusion protein ($P < 0.05$). Survival curves for strains 794 J (*kdr*) and UKO (*super-kdr*), which both show 40% survival over the assay, differ significantly from controls, from wild-type survival and from strain 4824 J survival ($P < 0.05$). Growth retardation was observed in all aphids exposed to fusion proteins, but was least in strain 4824 J (Fig. 2B), where aphids were able to produce nymphs during the assay period, as did the controls. No other aphid strain

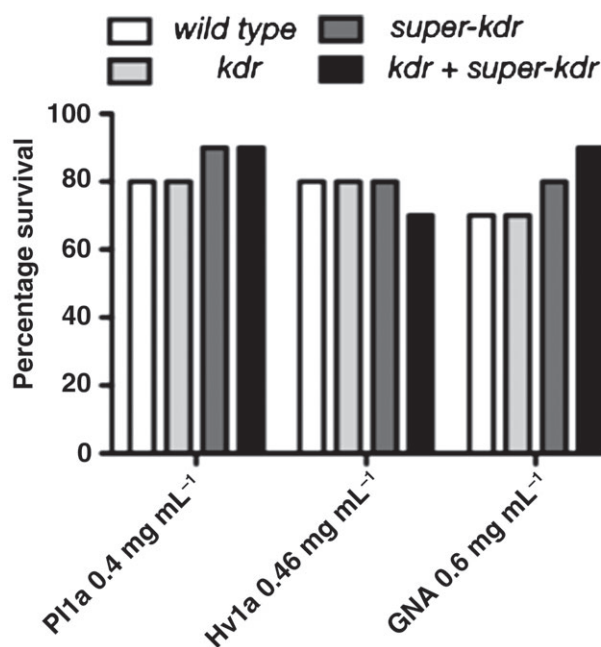

Figure 1. Toxicity of fusion protein components towards *M. persicae*. Graph shows survival after 7 days of pyrethroid-tolerant *M. persicae* strains (794 J, *kdr*; UKO, *super-kdr*; 4824 J, *kdr + super-kdr*) and wild-type 4106A strain after feeding on artificial diet containing 0.4 mg mL⁻¹ of P11a, 0.46 mg mL⁻¹ of Hv1a or 0.6 mg mL⁻¹ of GNA. Survival on control diet was 100% for all aphid strains over this interval. $n = 20$ aphids per replicate.

exposed to treatment was able to produce nymphs. The data demonstrate a differential effect of the fusion protein on the different aphid strains, with *wild-type* strains fully susceptible to the toxin at this concentration, whereas the *kdr* and *super-kdr* strains are partially tolerant, and the *kdr + super-kdr* strain is almost completely tolerant.

By analysing survival curves for aphids exposed to different concentrations of P11a/GNA, LC_{50} values for the different strains could be deduced. The values obtained range from 0.35 to 1.76 mg mL⁻¹, and are shown in Table 1. There is a strong correlation between insecticide resistance of aphid strains and the estimated LC_{50} values; wild-type susceptible aphids have the lowest LC_{50} , and the order of insecticide tolerance (*wild type* < *kdr* < *super-kdr* < *kdr + super-kdr*) is reflected in the LC_{50} values (*wild type* < *kdr* < *super-kdr* < *kdr + super-kdr*). The *kdr + super-kdr* strain 4824 J has an estimated LC_{50} of 1.76 mg mL⁻¹ for P11a/GNA; recombinant protein at 2.0 mg mL⁻¹ caused significant effects on survival, and treatment with 2.5 or 3.0 mg mL⁻¹ of P11a/GNA resulted in complete mortality (Fig. 2C).

3.3 Toxicity of Hv1a/GNA recombinant fusion protein

An insecticidal fusion protein containing the calcium-channel-specific toxin Hv1a was used as a control to identify non-specific effects on sensitivity towards insecticidal compounds in the pyrethroid-resistant *M. persicae* strains. Purified recombinant Hv1a/GNA fusion protein was fed to each strain at a range of concentrations, and survival curves were plotted for all treatments. Results for feeding at 1 mg mL⁻¹ are shown in Fig. 3A. Hv1a/GNA fusion protein at this concentration caused complete mortality to strains 4106A (*wild type*) and UKO (*super-kdr*) after 6 days, and to strains 794 J (*kdr*) and 4824 J (*kdr + super-kdr*) after 9 days. The survival curves show significant differences between all strains

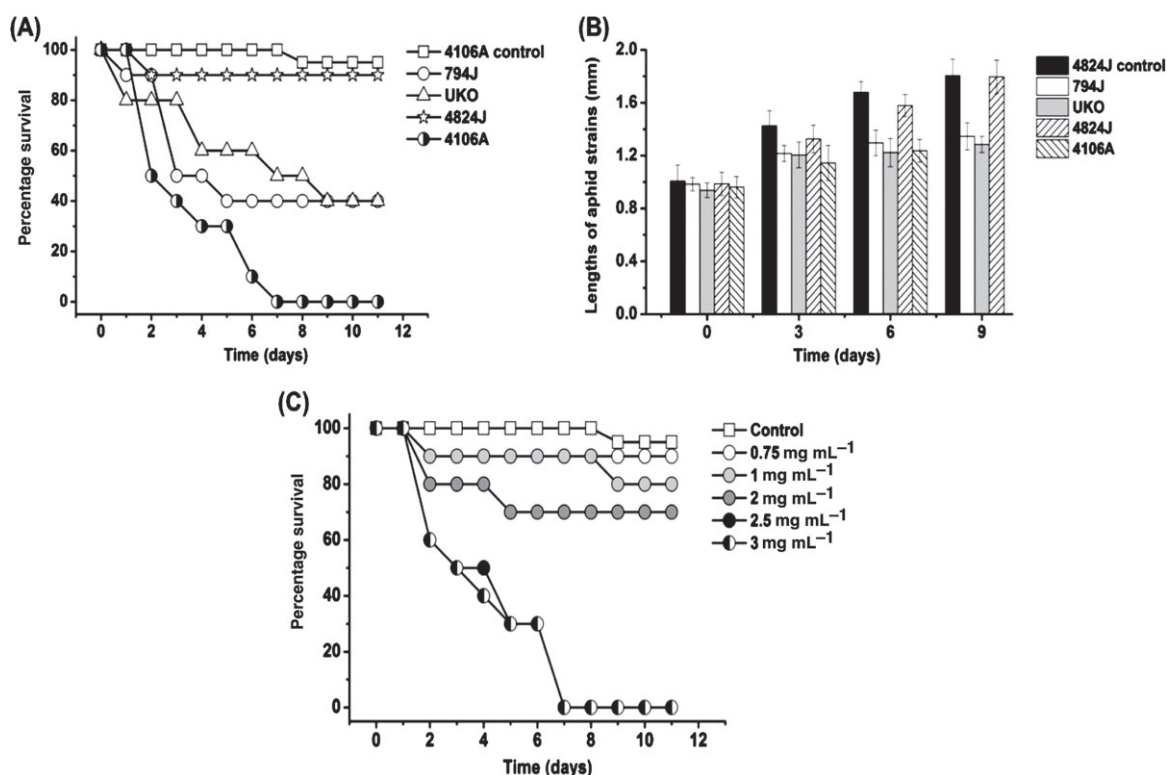

Figure 2. (A) Toxicity of PI1a/GNA fusion protein towards *M. persicae*. Graph shows survival curves of pyrethroid-tolerant *M. persicae* strains (794 J, *kdr*; UKO, *super-kdr*; 4824 J, *kdr + super-kdr*) and wild-type 4106A strain fed PI1a/GNA at 1 mg mL⁻¹. All aphid strains on control diet showed survival similar to that presented for 4106A strain. *n* = 20 aphids per replicate. (B) Growth suppression by PI1a/GNA fusion protein. Graph shows lengths of aphid strains (794 J, *kdr*; UKO, *super-kdr*; 4824 J, *kdr + super-kdr*) and wild-type 4106A strain from neonate to adult (9 days) after feeding on artificial diet containing 1 mg mL⁻¹ of PI1a/GNA (*n* = 3 per treatment). 100% mortality for strain 4106A prevented analysis for day 9. Data for strain 4824J fed on control diet are shown, but all aphid strains fed on control diet were of comparable size at each time point. (C) Dose–response effects of PI1a/GNA. Graph shows survival curves of 4824 J (*kdr + super-kdr*) *M. persicae* strain fed diets containing different concentrations of PI1a/GNA in the range 0–3.0 mg mL⁻¹. *n* = 20 aphids per replicate.

Table 1. Estimated LC₅₀ values for fusion proteins towards wild-type and pyrethroid-tolerant strains of *M. persicae*. Values were calculated from dose–response curves fitted to survival data after 9 days of exposure to diets containing fusion proteins at varying concentrations

Genotype (strain)	LC ₅₀ (mg mL ⁻¹) PI1a/GNA	LC ₅₀ (mg mL ⁻¹) Hv1a/GNA
4106A (wild type)	0.35	0.19
794 J (<i>kdr</i>)	0.60	0.28
UKO (<i>super-kdr</i>)	0.83	0.25
4824 J (<i>kdr + super-kdr</i>)	1.76	0.20

fed fusion protein and the controls not fed fusion protein (100% survival over 11 days) (*P* < 0.05), in agreement with previous assays showing that this fusion protein is insecticidal. Growth retardation was observed in all aphids exposed to fusion proteins (Fig 3B), and no aphids exposed to treatment were able to produce nymphs. Comparison of individual survival curves when Hv1a/GNA was fed at 1 mg mL⁻¹ suggested that strain 4824 J (*kdr + super-kdr*) was more tolerant to Hv1a/GNA than wild-type aphids (strain 4106A) (difference between survival curves at *P* < 0.05), but that other differences were not significant. Assays at other concentrations of Hv1a/GNA did not give consistently significant differences between treatments, although the wild-type strain always showed greater susceptibility to the fusion protein than the pyrethroid-resistant strains.

LC₅₀ values for Hv1a/GNA in the different aphid strains were deduced by analysis of survival curves for aphids exposed to different concentrations of fusion protein. The values obtained range from 0.19 to 0.28 mg mL⁻¹ and are shown in Table 1. The estimated LC₅₀ values show no significant differences between any of the aphid strains, although the wild-type strain, 4106A, has the lowest LC₅₀ value. The uncertainties in estimated LC₅₀ values are relatively large compared with the differences, but the fitted dose–response curve for the wild-type strain differs significantly from the other curves (*P* < 0.05), supporting the conclusion that this strain is more susceptible to Hv1a/GNA.

4 DISCUSSION

The insect sodium channel is a major target for conventional pesticides, such as pyrethroids. The PI1a toxin, which acts on the same target, could represent a novel type of insecticidal component as a substitute for pyrethroids. The mode of binding of this toxin would be expected to differ significantly from binding a small molecule channel blocker like a pyrethroid, with contacts between the toxin and the channel potentially extending over a wider area. However, PI1a/GNA fusion protein exhibits reduced toxicity towards pyrethroid-resistant peach-potato aphid (*Myzus persicae*) strains, showing that the mutations, which remove sensitivity to pyrethroids, also affect the binding of PI1a. The mutations that give pyrethroid sensitivity are in domain II of the sodium channel, with the mutation at L1014 in helix S6 and the mutation at M918 in the linker between helices S4–S5. Changes to the spatial

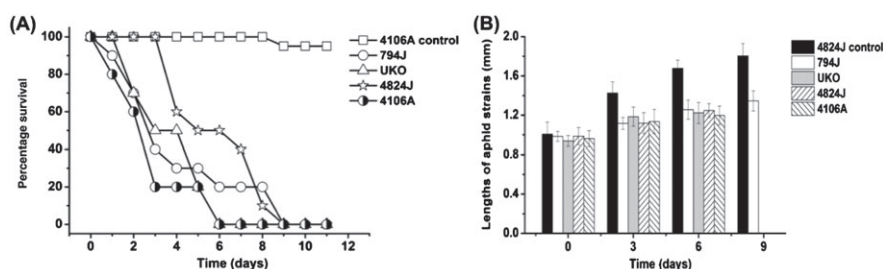

Figure 3. (A) Toxicity of Hv1a/GNA fusion protein towards *M. persicae*. Graph shows survival of pyrethroid-tolerant *M. persicae* strains (794 J, *kdr*; UKO, *super-kdr*; 4824 J, *kdr* + *super-kdr*) and wild type 4106A strain fed on diet containing 1 mg mL^{-1} of Hv1a/GNA. All aphid strains on control diet showed survival similar to that presented for the 4106A strain. $n = 20$ aphids per replicate. (B) Growth suppression by PHv1a/GNA fusion protein. Graph shows lengths of aphid strains (794 J, *kdr*; UKO, *super-kdr*; 4824 J, *kdr* + *super-kdr*) and wild-type 4106A strain from neonate to adult after feeding on artificial diet containing 1 mg mL^{-1} of Hv1a/GNA ($n = 3$ per treatment). 100% mortality for strains UKO, 4824 J and 4106A prevented analysis for day 9. Data for strain 4842 J fed on control diet are shown, but all aphid strains fed on control diet were of comparable size at each time point.

structure of domain II as a result of these mutations presumably also disturb the binding of PI1a to receptor site 4 in domain II. However, although the bioassays show that mutations in domain II of the insect sodium channel affect the insecticidal activity of the PI1a/GNA fusion protein, some toxicity is still observed, with a higher concentration of fusion protein required to cause mortality in the pyrethroid-resistant *kdr* and *super-kdr* strains. This result implies that either some interactions still exist between PI1a and domain IIS6 or domain IIS4–S5 linker of the mutated sodium channel, or that PI1a also binds to other sites on the sodium channel to cause inactivation. The extracellular loops of IIS1–S2 and IIS3–S4 are thought to be the main binding sites of PI1a, which are distinct from the pyrethroid binding site but contribute to receptor site 4 for toxins. The change in the spatial structure of domain II as a result of the *kdr* and *super-kdr* mutations may have a relatively small effect on toxin binding in the interaction between PI1a and the sodium channel, but may prevent the toxin inactivating the channel. The greater effect on channel structure caused by combining the mutations at L1014 and M918 would be expected to affect PI1a binding more than single mutations, in agreement with the lack of sensitivity to PI1a/GNA shown by aphid strain 4824 J.

As expected, when fusion protein containing the calcium-channel-specific toxin Hv1a is fed to aphids, there is no evidence for significant differential sensitivity between insecticide-resistant aphid strains, as the strains differ in mutations to the sodium channel. However, the observation that wild-type aphids are more susceptible to this toxin is unexpected. Mutations in sodium channels present in strains 794 J, UKO and 4824 J would be expected to result in a fitness cost to *M. persicae*, similar to that observed both for other insect-resistant aphids of this species³⁰ and for other insect species (e.g. when comparing insecticide-resistant and insecticide-susceptible German cockroaches, *Blattella germanica*³¹). A fitness cost for insecticide resistance in *M. persicae* can be inferred from population data; if there is no fitness cost, the population of resistant *M. persicae* should be much larger than wild type before selection occurs.³² The fitness cost would be expected to make insecticide-resistant strains of *M. persicae* more susceptible to Hv1a/GNA, but this is not the case. Possibly, other changes to the phenotype of insecticide-resistant aphids are affecting susceptibility to this fusion protein; a transcriptomic study³³ has suggested that insecticide resistance in *M. persicae* is complex and involves a broad array of resistance mechanisms. The present results support that conclusion.

The *kdr* strain of *M. persicae* is resistant to all pyrethroids, showing 23–73-fold increased resistance,¹ and the *kdr* + *super-kdr* strain is virtually immune to all the pyrethroids.³⁴ A fusion protein

containing the sodium-channel-specific PI1a toxin can cause 100% mortality towards pyrethroid-resistant aphids containing a single mutation in the sodium channel if administered at concentrations increased only threefold, but is not effective towards aphids containing a double mutation in the sodium channel. However, insecticide-resistant aphids are still sensitive towards a calcium-channel-specific toxin, albeit at higher doses than wild-type aphids. These experiments demonstrate the potential for fusion-protein-based biopesticides to complement existing pesticides, and to be used in the management of insecticide-resistant insect strains; the Hv1a/GNA fusion protein is currently undergoing trials leading to commercial use as a biopesticide.

ACKNOWLEDGEMENTS

Work described in this paper has been carried out with funding from the Technology Strategy Board (TSB) (TS/I000690/1) and BBSRC China Partnership Scheme (BB/G530409), which is acknowledged with gratitude. SY received support for his PhD programme jointly from the China Scholarship Scheme and a Durham University Doctoral Studentship; this funding is also gratefully acknowledged.

REFERENCES

- Eleftherianos I, Foster SP, Williamson MS and Denholm I, Characterization of the M918T sodium channel gene mutation associated with strong resistance to pyrethroid insecticides in the peach-potato aphid, *Myzus persicae* (Sulzer). *Bull Entomol Res* **98**:183–191 (2008).
- McCaffery A and Nauen R, The insecticide resistance action committee (IRAC): public responsibility and enlightened industrial self-interest. *Outlooks Pest Manag* **17**:11–14 (2006).
- Catterall WA, From ionic currents to molecular mechanisms: the structure and function of voltage-gated sodium channels. *Neuron* **26**:13–25 (2000).
- Vassilevski AA, Kozlov SA and Grishin EV, Molecular diversity of spider venom. *Biochemistry (Mosc)* **74**:1505–1534 (2009).
- Zlotkin E, The insect voltage-gated sodium channel as target of insecticides. *Annu Rev Entomol* **44**:429–445 (1999).
- Du Y, Lee J, Nomura Y, Zhang T, Zhovor B and Dong K, Identification of a cluster of residues in transmembrane segment 6 of domain III of the cockroach sodium channel essential for the action of pyrethroid insecticides. *Biochem J* **419**:377–385 (2009).
- Du Y, Nomura Y, Satar G, Hu Z, Nauen R, He SY, *et al*, Molecular evidence for dual pyrethroid–receptor sites on a mosquito sodium channel. *Proc Natl Acad Sci USA* **110**:11 785–11 790 (2013).
- Williamson MS, Martinez-Torres D, Hick CA and Devonshire AL, Identification of mutations in the housefly *para*-type sodium channel gene

- associated with knockdown resistance (*kdr*) to pyrethroid insecticides. *Mol Gen Genet* **252**:51–60 (1996).
- 9 Martinez-Torres D, Chandre F, Williamson MS, Darriet F, Bergé JB, Devonshire AL, *et al*, Molecular characterization of pyrethroid knockdown resistance (*kdr*) in the major malaria vector *Anopheles gambiae* ss. *Insect Mol Biol* **7**:179–184 (1998).
 - 10 Kranthi KR, Jadhav DR, Kranthi S, Wanjarri RR, Ali SS and Russell DA, Insecticide resistance in five major insect pests of cotton in India. *Crop Prot* **21**:449–460 (2002).
 - 11 Miyazaki M, Ohyama K, Dunlap DY and Matsumura F, Cloning and sequencing of the *para*-type sodium channel gene from susceptible and *kdr*-resistant German cockroaches (*Blattella germanica*) and house fly (*Musca domestica*). *Mol Gen Genet* **252**(1–2):61–68 (1996).
 - 12 Rash LD and Hodgson WC, Review: pharmacology and biochemistry of spider venoms. *Toxicon* **40**:225–254 (2002).
 - 13 Whetstone PA and Hammock BD, Delivery methods for peptide and protein toxins in insect control. *Toxicon* **49**:576–596 (2007).
 - 14 Fitches E, Audsley N, Gatehouse JA and Edwards JP, Fusion proteins containing neuropeptides as novel insect control agents: snowdrop lectin delivers fused allatostatin to insect haemolymph following oral ingestion. *Insect Biochem Mol Biol* **32**:1653–1661 (2002).
 - 15 Fitches E, Edwards MG, Mee C, Grishin E, Gatehouse AM, Edwards JP, *et al*, Fusion proteins containing insect-specific toxins as pest control agents: snowdrop lectin delivers fused insecticidal spider venom toxin to insect haemolymph following oral ingestion. *J Insect Physiol* **50**:61–71 (2004).
 - 16 Fitches EC, Pyati P, King GF and Gatehouse JA, Fusion to snowdrop lectin magnifies the oral activity of insecticidal ω -hexatoxin-Hv1a peptide by enabling its delivery to the central nervous system. *PLoS ONE* **7**:e39389 (2012).
 - 17 Corzo G, Escoubas P, Stankiewicz M, Pelhate M, Kristensen CP and Nakajima T, Isolation, synthesis and pharmacological characterization of δ -palutoxins IT, novel insecticidal toxins from the spider *Paracoelotes luctuosus* (Amaurobiidae). *Eur J Biochem* **267**:5783–5795 (2000).
 - 18 Cestèle S and Catterall WA, Molecular mechanisms of neurotoxin action on voltage-gated sodium channels. *Biochimie* **82**:883–892 (2000).
 - 19 Yang S, Pyati P, Fitches E and Gatehouse JA, A recombinant fusion protein containing a spider toxin specific for the insect voltage-gated sodium ion channel shows oral toxicity towards insects of different orders. *Insect Biochem Mol Biol* **47**:1–11 (2014).
 - 20 Tedford HW, Fletcher JI and King GF, Functional significance of the β -hairpin in the insecticidal neurotoxin ω -atracotoxin-Hv1a. *J Biol Chem* **276**:26 568–26 576 (2001).
 - 21 Fletcher JI, Smith R, O'Donoghue SI, Nilges M, Connor M, Howden ME, *et al*, The structure of a novel insecticidal neurotoxin, ω -atracotoxin-HV1, from the venom of an Australian funnel web spider. *Nat Struct Biol* **4**:559–566 (1997).
 - 22 Tedford HW, Gilles N, Ménez A, Doering CJ, Zamponi GW and King GF, Scanning mutagenesis of ω -atracotoxin-Hv1a reveals a spatially restricted epitope that confers selective activity against insect calcium channels. *J Biol Chem* **279**:44 133–44 140 (2004).
 - 23 Chong Y, Hayes JL, Sollod B, Wen S, Wilson DT, Hains PG, *et al*, The ω -atracotoxins: selective blockers of insect M-LVA and HVA calcium channels. *Biochem Pharmacol* **74**:623–638 (2007).
 - 24 King GF, Tedford HW and Maggio F, Structure and function of insecticidal neurotoxins from Australian funnel-web spiders. *Toxin Rev* **21**(4):361–389 (2002).
 - 25 Saez NJ, Senff S, Jensen JE, Er SY, Herzig V, Rash LD, *et al*, Spider-venom peptides as therapeutics. *Toxins* **2**:2851–2871 (2010).
 - 26 Baumgartner P, Harper K, Raemaekers RJM, Durieux A, Gatehouse AMR, Davies HV, *et al*, Large-scale production and purification of recombinant *Galanthus nivalis* agglutinin (GNA) expressed in the methylotrophic yeast *Pichia pastoris*. *Biotechnol Lett* **25**:1281–1285 (2004).
 - 27 Gatehouse JA, Yang S, Pyati P and Fitches EC, Pesticidal fusion protein improvements. UK Patent Applic. No. 1321938.1 (2013).
 - 28 Prosser WA and Douglas AE, A test of the hypotheses that nitrogen is upgraded and recycled in an aphid (*Acyrtosiphon pisum*) symbiosis. *J Insect Physiol* **38**:93–99 (1992).
 - 29 Down RE, Fitches EC, Wiles DP, Corti P, Bell HA, Gatehouse JA, *et al*, Insecticidal spider venom toxin fused to snowdrop lectin is toxic to the peach-potato aphid, *Myzus persicae* (Hemiptera: Aphididae), and the rice brown planthopper, *Nilaparvata lugens* (Hemiptera: Delphacidae). *Pest Manag Sci* **62**:77–85 (2006).
 - 30 Castañeda LE, Barrientos K, Cortes PA, Figueroa CC, Fuentes-Contreras E, Luna-Rudloff M, *et al*, Evaluating reproductive fitness and metabolic costs for insecticide resistance in *Myzus persicae* from Chile. *Physiol Entomol* **36**:253–260 (2011).
 - 31 Ang LH and Lee CY, Absence of a fitness penalty in insecticide-resistant German cockroaches, *Blattella germanica* (L.) (Dictyoptera: Blattellidae). *Int J Pest Manag* **57**:195–204 (2011).
 - 32 Fenton B, Margaritopoulos JT, Malloch GL and Foster SP, Micro-evolutionary change in relation to insecticide resistance in the peach–potato aphid, *Myzus persicae*. *Ecol Entomol* **35**:131–146 (2010).
 - 33 Silva AX, Jander G, Samaniego H, Ramsey JS and Figueroa CC, Insecticide resistance mechanisms in the green peach aphid *Myzus persicae* (Hemiptera: Aphididae) I: a transcriptomic survey. *PLoS ONE* **7**:e36366 (2012).
 - 34 Anstead JA1, Williamson MS, Eleftherianos I and Denholm I, High-throughput detection of knockdown resistance in *Myzus persicae* using allelic discriminating quantitative PCR. *Insect Biochem Mol Biol* **34**:871–877 (2004).



Intellectual
Property
Office

Concept House
Cardiff Road, Newport
South Wales
NP10 8QQ
United Kingdom

Telephone +44 (0)1633 814000

Website www.ipo.gov.uk

Electronic Filing Receipt

Marks & Clerk LLP
1 New York Street
Manchester
Greater Manchester
United Kingdom
M1 4HD

Your Ref: PM336301GB

11 December 2013

PATENT APPLICATION NUMBER 1321938.1

We have received your request for grant of a patent and recorded its details as follows:

Filing date(*)	11 December 2013
Earliest priority date (if any)	
Applicant(s) / contact point	University of Durham, The Food and Environment Research Agency (FERA), representing the Secretary of State for Environment, Food and Rural Affairs
Application fee paid	No, pay by 11 December 2014
Description (number of pages or reference)	49
Certified copy of referenced application	Not applicable
If description not filed	Not applicable
Claims (number of pages)	No, file by 11 December 2014
Drawings (number of pages)	12
Abstract (number of pages)	1
Statement of inventorship (Form 7)	No, file by 11 April 2015
Request for search (Form 9A)	No, file by 11 December 2014
Request for examination (Form 10)	None
Priority Documents	None
Other Attachments Received	Pre-conversion archive PM336301GB Precon-version.zip

Durham University Business and Innovation Services
Mountjoy Centre

INVENTION RECORD QUESTIONNAIRE

Please return by internal mail to:

Durham University Business and Innovation Services
Maple Wing, Mountjoy Centre, Durham DH1 3LE

INVENTION RECORD QUESTIONNAIRE

1. Short, descriptive title of the invention

Pesticidal Fusion Protein Improvements – pro-region enhancement

2. What do you think the invention is? (Describe in not more than a few sentences what is novel about your invention.)

It has been found that inclusion of the pro-region in the expression construct for pesticidal fusion proteins can bring about substantially enhanced biological activity for the recombinant toxin. The finding that this enhancement in toxicity can in the region of a 4 to 8 fold increase indicates that this is a likely to be important commercially because of the potential to reduce costs of manufacturing active agents. Inclusion of the pro-region in the expression construct is thought to influence protein folding even where the pro-region is not retained in the final product.

3. How and why does it work? (You could use sketches, drawings, flow sheets, and chemical equations etc, to help understanding by others. Continue on a separate sheet if necessary.)

Existing pesticidal fusion proteins, as claimed in an earlier patent, are produced by combining the coding sequences of snowdrop lectin ("carrier") with a variety of potentially pesticidal proteins or peptides ("toxins") which need to be delivered to the circulatory system of the target pest. Genes encoding the fusion proteins are formed by combining DNA sequences, which are then transcribed and translated into proteins using a recombinant expression system; the yeast *Pichia pastoris* has been used for this purpose. This is a eukaryotic microorganism and can fold proteins from eukaryotes better than a bacterium like *E. coli*; neither the "carrier" or "toxin" components of the fusion proteins being used currently will express in functional form in *E. coli*, as a result of failing to fold properly.

The expression system used in *P. pastoris* allows proteins to be secreted into the culture supernatant, which makes purification and other downstream processing much more straightforward for large-scale production.

Experiments in which the toxin components of fusion proteins were expressed in *P. pastoris* without being fused to the snowdrop lectin "carrier" component, or in combination with a different potential "carrier", showed that the resulting products had low, or no biological activity when compared to literature values for toxins purified from natural sources. (Assayed in terms of dose required for mortality when injected into insects.) These results suggested that the toxin protein was not folding properly when expressed without fusion to the carrier, and that snowdrop lectin assisted correct folding of the toxin.

To attempt to improve the folding of recombinant toxins, the genes encoding these proteins were examined. The arthropod toxins used in most of the fusion proteins are small, cysteine-rich proteins belonging to several superfamilies of protein sequences (which include toxins from organisms other than arthropods). Their encoding genes include two sequences that are not present in the final protein product; a predicted N-terminal signal peptide that is removed during translation, and a predicted pro-region, between the signal peptide and the final sequence of the protein as isolated. Based on existing literature, we hypothesised that inclusion of the pro-region in the expression construct would be likely to result in improved folding of the toxin when expressed in *P. pastoris*.

4. **What is new about your invention and how does it improve on the present situation?** *(You might wish to answer one or more of the following questions; what are the technical problems it will solve? What are the commercial problems it will solve?)*

It is proposed that pro-region enhancement is not specific to one toxin but can be more generally adopted to enhance toxicity of pesticidal fusion proteins. Furthermore, enhancement is not restricted to the native pro-region for a toxin opening up the possibility that pro-regions can be "designed" for toxins when full sequences are not available, giving the method more general applicability.

5. **Are there any other uses of the invention?** *(This answer will help to get the broadest possible patent protection and identify other areas where there may be a relevant prior art)*

The invention is specific to enhancing fusion proteins but could be broadly applicable across the range of candidate toxins and carriers.

6. **Do you know of any published literature relevant to your invention? Where have you looked and what did you find?** *(The literature includes other patents, patent applications, published papers, conference proceedings, trade literature, etc)*

This is reviewed in a draft paper that is being withheld until after a patent has been filed and has been taken into consideration by the patent attorney when drafting the patent.

7. **Has your invention only been demonstrated in your laboratory, or has it been used outside? If yes, please summarise the results that best demonstrate the invention. Please tell us where the results are recorded.** *(You may attach a copy of the relevant report if this is more convenient. Test results provide evidence that the invention works and gives the intended result)*

The invention has not been publicly disclosed. The results are recorded in a draft paper that is being withheld until after a patent has been filed and separately recorded as examples in the draft patent.

8. **When and where was the idea of the invention first conceived?** *(it is especially important to note whether the invention was made in collaboration with people in other universities or companies)*

The hypothesis and experiments were conducted by the research group during 2012 and 2013.

9. **Names of the inventors?** *(The full name (not just initials) and complete post office address (including postal code, citizenship and name and location of the employer) of each inventor should be given.)*

Professor John A Gatehouse (Durham University, Department of Biological & Biomedical Sciences, South Road, Durham, DH1 3LE)
1 Iveston Terrace, Stanley, County Durham, DH9 8RA

Dr Elaine C Fitches (Food & Environment Research Agency –FERA, Sand Hutton, York YO41 1IZ)
Schoolview, Carlton-in-Cleveland, Middlesbrough, TS9 7BB

Prashant S Pyati (Durham University, Department of Biological & Biomedical Sciences, South Road, Durham, DH1 3LE)
4 The Leazes, Bowburn, Durham, DH6 5AA

Sheng Yang (Durham University, Department of Biological & Biomedical Sciences, South Road, Durham, DH1 3LE)
37 Geoffery Avenue, Durham, DH1 4PF

10. Have you told anyone about the invention? How and when did you do this?

No.

11. When did you make the first notes/sketches?

An outline was circulated for discussion at a meeting held on 12th April 13 with Durham / Fera and Marks & Clerk Patent Attorneys.

12. Since the original conception of the idea, have you performed any further experiments to demonstrate some (not necessarily all) of the potential of the invention. If so, who carried out the experiments? Who was present, other than the inventors? Where are the results recorded?

Further research by the inventors is continuing.

13. Who funded the project/work that gave rise to the invention?

The research from which the invention arose was not externally funded. The research was conducted under the Durham University / FERA Fusion Protein collaboration is a development of the joint background IP falling outside any of the externally funded research contracts of the collaboration.

14. This record drawn up by me/us or under my/our direction and

signed on 13th March 2014

by:

Inventor 1 JA Guttenberg

Inventor 2 E. F. H. H. H. H. H.

Inventor 3 [Signature]

Inventor 4 [Signature]

**TECHNOLOGY TRANSFER OFFICE
MOUNTJOY RESEACH CENTRE**

Intellectual Property Income Distribution Form

This summary form should be completed by all contributors to a new invention or other form of intellectual property. Individual contributors must each also complete Form IP/I.

1. The University of Durham's Regulations require researchers who contribute jointly to intellectual property to agree between themselves the proportion of exploitation income to which each will be entitled from the net revenue payable to researchers under the University's revenue-sharing scheme.
2. Contributors are asked to state below the relative percentage share of researchers' benefits due to each.
3. This percentage will be taken as indicative of the relative value of the contribution of each.
4. The percentage shares will be used to assist the University's negotiation of revenue-sharing agreements with external sponsors of research who supported the work which led to the creation of the intellectual property in question (where such sponsors require a revenue share).
5. The percentage shares will also be used as the basis for revenue-sharing arrangements between the University and other collaborating institutions, where one or more of the contributors to the intellectual property are employed by (or are students of) another university.

Working title of intellectual property

Pesticidal Fusion Protein Improvements – pro-region enhancement

UK Patent Application No. 1321938.1 filed on 11th December 2013

Patent Number:
Methods of increasing the biological activity of toxins

Patent Title:
(if known)

(If the project only involves know how, write "none" next to the patent number)

We, the undersigned, agree that our individual contributions to the intellectual property named above were, at the time of signature, as follows:

DURHAM INVENTORS PERCENTAGE CONTRIBUTION				
Name	Percentage Contribution	Inventor (I) or Contributor (C)? ¹ Specify which	Signature	Date
John Gatehouse	70	I		
Prashant Pyati	10	C		
Sheng Yang	20	C		
Total	100%			

FERA INVENTORS PERCENTAGE CONTRIBUTION				
Name	Percentage Contribution	Inventor (I) or Contributor (C)? ¹ Specify which	Signature	Date
Elaine Fitches	100%	I		
Total	100%			

¹ Contributors who are not formally recognised as inventors for the purposes of patent law must have made a significant and identifiable contribution to the development of the technology.

Royalties can be distributed only after this form has been completed. University employees and ex-employees, will be paid via the University payroll (net) or by cheque (gross), depending on their status and/or contract of employment. Inventors who have never been employed by the University will be sent a cheque for the royalty less tax at the basic rate but no national insurance will be deducted. Alternatively, they may be paid via their employing institution, depending on revenue-sharing arrangements with the collaborating institution.

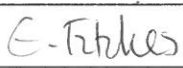
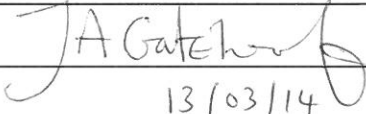
Full Name: Elaine Charlotte Fitches	Full Name: John Arthur Gatehouse
Title (Professor, Dr, etc) Dr	Title (Professor, Dr, etc) Professor
National Insurance No. NM 58 89 82 B	National Insurance No. . YR 45 23 49 B
Home Address: Schoolview, Carlton-in-Cleveland, Middlesbrough TS9 7BB	Home Address: 1 Iveston Terrace, Stanley, County Durham, DH9 8RA
Email Address: Elaine.fitches@fera.gsi.gov.uk	Email Address: J.A.Gatehouse@dur.ac.uk
<i>Please inform us of any change of address</i>	<i>Please inform us of any change of address</i>
Nationality: British	Nationality: British
Have you ever been employed by Durham University? NO	Have you ever been employed by Durham University? YES
Date of birth: 20/03/1967	Date of birth: 02/05/51
Signature: 	Signature: 
Date: 13/03/14	Date: 13/03/14

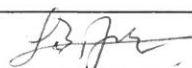
Full Name: Prashant Shivasharan Pyati	Full Name: Sheng Yang
Title (Professor, Dr, etc) Dr	Title (Professor, Dr, etc) Mr
National Insurance No: SH005654C	National Insurance No. N/A
Home Address: 4 The Leazes, Bowburn, Durham, DH6 5AA	Home Address: 37 Geoffery Avenue, Durham, DH1 4PF
Email Address: p.s.pyati@dur.ac.uk	Email Address: sheng.yang@dur.ac.uk
<i>Please inform us of any change of address</i>	<i>Please inform us of any change of address</i>
Nationality: Indian	Nationality: Chinese
Have you ever been employed by Durham University? YES	Have you ever been employed by Durham University? NO
Date of birth: 30/11/78	Date of birth: 23/11/83
Signature: 	Signature: 
Date: 13/03/14	Date: 13/03/14

For completion by "Durham University":

Is this invention being pursued as a UK patent, a non-UK patent or both?

UK priority patent application initially with PCT and International applications to be decided later, as agreed by Durham University and FERA

Signed by Project Manager: *SM Whiteley* Technology Transfer Manager

For completion by Technology Transfer Office

I confirm that there are:

- a) entitlements to third-party research funders or collaborators.
- b) There is a revenue-sharing arrangement with third party research funders or collaborators detailed as follows (if appropriate, a copy of the relevant agreement is enclosed):

Durham/FERA Patent Assignment and Licence Back agreement dated 22nd February 2012 for the exploitation of patent application A 110548.6 filed on 31st March 2011 'Spider Toxin Pesticide'. As the new disclosure relates to an improvement that will support commercial exploitation of it is proposed that the disclosure be included under an extension agreement mirroring the terms of the existing agreement .

- c) The invention was funded with support from a UK research council (detailed below):

d) Revenue sharing arrangements, if appropriate, negotiated by:..... (Technology Transfer Office)

Details filed on

Signed on behalf of Technology Transfer Office: *SM Whiteley*

Date: *13th March 2014*