

Durham E-Theses

*Studies on the auchenorrhyncha (hemoptera –
insecta) of Pennine moorland with special reference to
the ceropidae*

John B. Whittaker

How to cite:

Whittaker, John B. (1963) Studies on the auchenorrhyncha (hemoptera – insecta) of Pennine moorland with special reference to the ceropidae. Doctoral thesis, Durham University.

Use policy

The full-text may be used and/or reproduced, and given to third parties in any format or medium, without prior permission or charge, for personal research or study, educational, or not-for-profit purposes provided that:

- a full bibliographic reference is made to the original source
- a <https://etheses.durham.ac.uk/id/eprint/10475/> is made to the metadata record in Durham E-Theses
- the full-text is not changed in any way

The full-text must not be sold in any format or medium without the formal permission of the copyright holders.

Please consult the [full Durham E-Theses policy](#) for further details.

[L59]
M. D. S. 153

ABSTRACT

Studies on the Auchenorrhyncha (Homoptera - Insecta) of Pennine Moorland with special reference to the Cercopidae.

Notes on the autecology of 32 species of Auchenorrhyncha from the Moor House National Nature Reserve are given. Studies were made of the microclimates of the common vegetation types on which these occur and it is shown that the size and function as a temperature regulator of the spittle (produced by nymphs of the Cercopidae) is associated with these gradients.

Cercopid nymphs are shown to change feeding sites after moulting.

The need to change host plants and thus leave protective spittle is thought to result in an increased mortality of nymphs (up to 3 per cent per day). Overall nymphal mortality is not dependent on population density.

In two cercopids (Neophilaenus lineatus and Neophilaenus exclamationis), there are marked changes in population density in each year (1961 to 1963) and these are partly attributed to climatic factors. The hatch of Cercopidae is delayed, and development is retarded at high altitudes.

Nymphal mortality rates in a cicadellid (Macrosteles sexnotatus) and a delphacid (Conomelus anceps) did not differ from those of the Cercopidae studied, although they have no protective spittle.

It is concluded that cercopid spittle is of some survival value at Moor House by enabling the nymph to avoid parasites, if not predators, and unfavourable climatic conditions encountered whilst remaining stationary on the host plant during feeding. These advantages are not sufficient to

give the Cercopidae a significantly higher survival rate than other Auchenorrhyncha at Moor House.

Non-density dependent factors are thought to be responsible for a major part of the changes in population density. A compensatory mechanism at other stages of the life cycle has not been demonstrated. Local extinction at the edge of the range is a result of climatic factors. The population studied is probably below the density level at which regulating mechanisms may occur.

**JOHN B. WHITTAKER,
ZOOLOGY DEPARTMENT,
DURHAM UNIVERSITY.**

STUDIES ON THE AUCHENORRHYNCHA (HEMIPTERA - INSECTA)
OF PENNINE MOORLAND WITH SPECIAL REFERENCE TO THE
CERCOPIDAE

by

John B. Whittaker, B.Sc.

(University College)

... being a thesis presented in candidature for the
degree of Doctor of Philosophy in the University of
Durham, 1963.

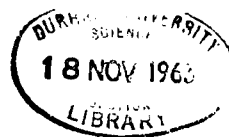

ACKNOWLEDGEMENTS

The writer wishes to express his sincere thanks to Professor J. B. Cragg and Dr. J. C. Coulson who supervised the work and offered helpful advice and criticism, and Professor D. Barker for continued facilities in the Department of Zoology, Durham.

Thanks are also due to :

Members of the Department of Zoology for helpful discussion, the staff of the Moor House Research Station, and particularly Messrs. A. Eddy and D. Welch for Botanical information concerning the Moor House Reserve,

Dr. W. E. China for permission to study the collection of the British Museum (Natural History),

Mrs. A. Simpson for typing the final draft,

Messrs. D. Kelly, D. Hutchinson and D. Whittaker for photographic assistance, and Miss H. M. Thorley for help in checking references.

The work was carried out whilst holding a Nature Conservancy Studentship.

CONTENTS

	Page
I INTRODUCTION	1
II THE STUDY AREA AND SAMPLING SITES	3
1. LOCATION AND GENERAL PHYSIOGRAPHY	3
2. THE SAMPLING SITES	4
a) THE JUNCUS SQUARROSUS SITE	4
b) THE NARDUS SITE	5
c) THE LIMESTONE GRASSLAND SITE	6
d) THE DORTH GILL TRANSECT	8
e) THE MIDDLE TONGUE TRANSECT	8
f) OTHER SAMPLE SITES	9
3. THE CLIMATE AT MOORHOUSE	10
III TAXONOMY AND AUTECOLOGY OF THE MOOR HOUSE	
AUCHENORRHYNCHA	13
1. TAXONOMY	13
a) GENERAL	13
b) THE CERCOPIDAE	16
2. CHECK LIST OF MOOR HOUSE AUCHENORRHYNCHA	17
3. AUTECOLOGY OF THE MOOR HOUSE AUCHENORRHYNCHA	20
4. PARASITES OF MOOR HOUSE AUCHENORRHYNCHA	26
5. AFFINITIES OF THE MOOR HOUSE AUCHENORRHYNCHA	27
IV SAMPLING TECHNIQUES	29
1. QUANTITATIVE SAMPLING OF CERCOPID NYMPHS	29
a) INTRODUCTION	29
b) PRELIMINARY SAMPLING	30

	Page
c) GRID SAMPLING	32
d) ERRORS IN THE GRID SAMPLING	33
i Destruction of spittles by the observer	33
ii Migrating nymphs or very small spittles	34
iii Relative efficiency of sampling instars	35
e) EFFECT OF SAMPLING ON THE NEXT YEAR'S POPULATION	37
f) ESTIMATION OF POPULATION DENSITY BY PERCENTAGE ABSENCE	38
2. SAMPLING OF JASSIDAE, DELPHACIDAE AND ADULT CERCOPIDAE	42
a) SWEEP NET SAMPLING	42
b) SUCTION SAMPLING	43
i Operation of the apparatus	44
ii Efficiency of the apparatus	46
V THE MICROCLIMATES IN THE VEGETATION OF THE SAMPLE SITES	47
1. INTRODUCTION	47
2. COMPARISON OF JUNCUS AND LIMESTONE GRASSLAND SITES	47
3. COMPARISON OF HUMMOCKS AND HOLLOWES ON LIMESTONE GRASSLAND	50
4. THE MICROCLIMATE OF CERCOPID SPITTLE	52
5. THE EFFECT OF A HIGH TEMPERATURE GRADIENT ON AUCHENORRHYNCHA OTHER THAN NYMPHAL CERCOPIDAE	58
VI THE BIOLOGY OF NEOPHILAENUS LINEATUS	59
A. THE NYMPHAL INSTARS	59
1. INTRODUCTION	59
2. DETERMINATION OF INSTARS	60

	Page
3. DESCRIPTIONS OF THE INSTARS	63
4. DURATION OF INSTARS	65
a) IN THE FIELD	65
b) THE EFFECT OF TEMPERATURE ON THE DURATION OF INSTAR ONE	68
i In the laboratory	68
ii In the field	68
5. DENSITIES AND COMPOSITIONS OF THE N. LINEATUS POPULATIONS	69
6. HOST PLANTS OF NYMPHS AT MOOR HOUSE	73
B. THE SPATIAL DISTRIBUTION OF NYMPHS, AND THEIR MORTALITY	75
1. INTRODUCTION	75
2. STATISTICAL TREATMENT OF THE DATA	76
3. THE VARIANCE MEAN RATIO	78
4. VARIATIONS IN THE COEFFICIENT OF DISPERSION OF THE NYMPHS	79
a) THE JUNCUS SITE	79
b) THE NARDUS SITE	82
5. VARIATIONS IN THE COEFFICIENTS OF DISPERSION OF THE SPITTLES	85
a) THE JUNCUS SITE	85
b) THE NARDUS SITE	86
6. THE SPITTLE/NYMPH RATIO	86
a) THE SITUATION IN 1961	87
b) THE SITUATION IN 1962	87
7. THE NATURE OF THE INCREASE IN PERCENTAGE OF NYMPHS ON JUNCUS	89

	Page
8. REASONS FOR THE MOVE FROM FESTUCA TO JUNCUS	91
9. CONCLUSIONS	92
10. NYMPHAL MORTALITY ON THE SAMPLING AREA	97
a) INTRODUCTION	97
b) METHODS AND RESULTS	97
c) DISCUSSION	100
11. NYMPHAL MORTALITY IN EXPERIMENTAL POPULATIONS	104
C. THE ADULT	107
1. SEX RATIO	107
2. MORTALITY	107
3. COPULATION	108
4. OVARY DEVELOPMENT	109
5. OVIPOSITION	111
6. THE EGG	111
7. HATCHING	111
8. EGG MORTALITY	113
D. THE EFFECT OF ALTITUDE ON N. LINEATUS	115
1. INTRODUCTION	115
2. DORTH GILL TRANSECT 1961	116
3. MIDDLE TONGUE TRANSECT 1962	118
VII THE BIOLOGY OF NEOPHILAENUS EXCLAMATIONIS	124
1. INTRODUCTION	124
2. THE DISTRIBUTION OF NEOPHILAENUS LINEATUS AND NEOPHILAENUS EXCLAMATIONIS	125

	Page
3. THE NYMPHS	126
a) DETERMINATION OF INSTARS	126
b) DURATION OF INSTARS IN THE FIELD	127
c) DISTRIBUTION OF THE NYMPHS	128
d) MORTALITY OF THE NYMPHS	129
4. THE ADULT	130
a) DISTRIBUTION	130
b) MORTALITY	131
VIII STUDIES ON PHILAENUS SPUMARIUS	135
1. INTRODUCTION	135
2. HOST PLANTS AT MOOR HOUSE	136
3. COLOUR VARIETIES	137
IX POPULATION STUDIES ON OTHER AUCHENORRHYNCHA	141
1. INTRODUCTION	141
2. THE POPULATION DENSITY OF MACROSTELES SEXNOTATUS	142
3. THE POPULATION DENSITY OF CONOMELUS ANCEPS	143
4. COMPARISON OF THE MORTALITY IN THE NYMPHAL STAGES OF THE CERCOPIDAE, CICADELLIDAE, AND DELPHACIDAE STUDIED	145
X GENERAL DISCUSSION	147
SUMMARY	161
REFERENCES	166
APPENDIX	180
I APPARATUS	180
1. THE SUCTION SAMPLER	180

	Page
2. APPARATUS FOR RECORDING TEMPERATURES AND HUMIDITIES IN VEGETATION	180
a) THE RECORDING BRIDGE	180
b) THE THERMISTOR TYPES AND THEIR USE	182
i Temperature and humidity gradients in vegetation	182
ii Comparison of the Micro-hygrometer with an Assmann Psychrometer	184
iii Type P thermistor for spittle temperature measurement	185
c) CALIBRATION OF THERMISTORS	186

I. INTRODUCTION

Since 1952, studies of the fauna of the Moor House National Nature Reserve have been in progress. The need for detailed surveys of the animals of the Reserve has been pointed out by Cragg (1961), and the present study was undertaken with the aim of supplementing the general faunal data accumulating for the Reserve.

Many authors have laid stress on the great severity of the climate at Moor House. An opportunity has therefore been taken to study the Cercopidae in more detail than the rest of the Homoptera Auchenorrhyncha, because members of this group are able in the nymphal stages to provide themselves with a small enveloping micro-climate known as "cuckoo-spit". The existence of this spittle has also made possible quantitative sampling on a scale which would otherwise have been difficult under Pennine climatic conditions. The relatively low densities of Auchenorrhyncha at Moor House, compared with lowlands, has also limited the scope of the present study. The advantages of undisturbed study areas provided by a National Nature Reserve, and the usefulness of data collected on such a Reserve are, however, justifiable reasons for working there.

The British Cercopidae are represented by ten species which are members of four genera. Apart from initial descriptions of the species and occasional habitat records, only one of these species has received much attention in the literature. Philaenus spumarius is widely distributed in the Palaearctic and Nearctic regions and is a serious pest of alfalfa and other hay crops in the United States



and Canada and a considerable literature on its ecology has accumulated. The emphasis on this species has led to neglect of related genera, for example there appears to be only one detailed paper on Neophilaenus lineatus. This is the work of Garman (1921) who in general, records observations which are unsubstantiated by critical evidence. The species is less common than P. spumarius in lowland localities of Britain but is the most abundant cercopid of upland areas where it occurs on grasses, sedges and rushes. Its importance on these upland areas has made it the main subject of the present study although the discovery of Neophilaenus exclamationis at Moor House during the course of this work has allowed the study of a closely related species on which no literature has been found. It has been possible to estimate the mortality of the two Neophilaenus species at Moor House and so by way of comparison, data has also been collected on the mortality of representatives of the Cicadellidae and Delphacidae; groups of Homoptera Auchenorrhyncha which do not have protective spittle during the nymphal stages.

Many Auchenorrhyncha are polyphagous, and it is the opinion of several workers on the group (e.g. Kontkanen 1950), that microclimatic conditions may be more important factors in their distribution, than the details of the vegetational cover. In describing the habitats in which Auchenorrhyncha occur at Moor House, attention has been paid to the microclimatic conditions encountered in the various vegetation types. The effect of these on the spittles of Cercopidae is also discussed.

II. THE STUDY AREA AND SAMPLING SITES

1. LOCATION AND GENERAL PHYSIOGRAPHY

Most of the work described in this account was carried out on the Moor House National Nature Reserve (N.R. 80) Westmorland, which occupies 10,000 acres (4,000 hectares) of the Pennines (Nat. Grid. Ref. NY/758329). The Reserve lies 12 miles to the east of Penrith and 11 miles to the south of Alston. On the west lies the Pennine escarpment which rises from the Vale of Eden up to the summit ridge formed by the rounded tops of Great Dun Fell (2,780 feet; 845 m.), Little Dun Fell (2,761 feet; 842 m.) and Knock Fell (2,604 feet; 794 m.). This ridge is continuous with Cross Fell (2,930 feet; 893 m.), the highest point of the Pennines, which lies just outside the northern boundary of the Reserve. The greater part of the Reserve slopes in an easterly direction from the summits down to the River Tees, which bounds the Reserve on the north and east. This part of the area has an extensive cover of glacial drift overlaid by peat which reaches 12 feet in thickness in places. The Reserve is dissected by numerous streams flowing into the Tees on the east and the Eden on the west. These often expose the Carboniferous Yoredale rocks which are made up of repeated bands of limestone, shale and sandstone, with thin coal seams.

Most of the surface is covered by blanket bog except on the higher slopes and along the stream valleys where shallower peat or mineral soils allow the existence of rush and grass dominated areas.

PLATE 1. THE JUNCUS SITE.

- A. General view. The Juncus squarrosus is bounded on the upper side by Calluna, and along its lower edge by a narrow belt of Juncus effusus.**
- B. Detail of the vegetation. The Juncus (darker areas) and Festuca can be distinguished, and one of the pegs for the sample grid is visible.**



Trees were not introduced on to the Reserve until 1954. The general features of the Reserve have been described by Conway (1955) and Cragg (1961), and Johnson and Dunham (1963) have published a detailed monograph of the geology of the area.

2. THE SAMPLING SITES

From the area described, sampling sites were selected for study.

a) THE JUNCUS SQUARROSUS SITE (1,800 feet; 549 m.) PLATE 1.

A characteristic vegetation in which Juncus squarrosus is dominant occurs at the edge of mixed moor vegetation where the peat is better drained and shallower than on the Calluna moor. Juncus squarrosus, Festuca ovina and Polytrichum commune are the main constituents of the flora (Table 1). The vegetation analyses used in this section are from the Moor House records.

TABLE 1. DOMIN ANALYSIS OF THE JUNCUS SITE VEGETATION

	Metre Square Quadrats				
	1	2	3	4	5
Juncus squarrosus					
Shoot number	19	11	18	16	18
Domin scale	7	6	7	7	7
Agrostis tenuis	-	-	-	-	2
Carex nigra	3	3	-	3	2
Deschampsia flexuosa	1	-	1	1	-
Eriophorum vaginatum	-	4	-	-	-
E. angustifolium	2	-	1	-	-
Festuca ovina	5	5	5	7	5
Polytrichum commune	4	5	4	-	4

PLATE 2. THE NARDUS SITE.

A. General view with Valley Bog in the background.

B. A portion of the grid with the pegs visible.



**FIG. 1 MAP OF THE MOOR HOUSE NATIONAL NATURE
RESERVE**

**One hundred foot contours are marked, and
the numbers refer to the sample sites.**

FIG. 1

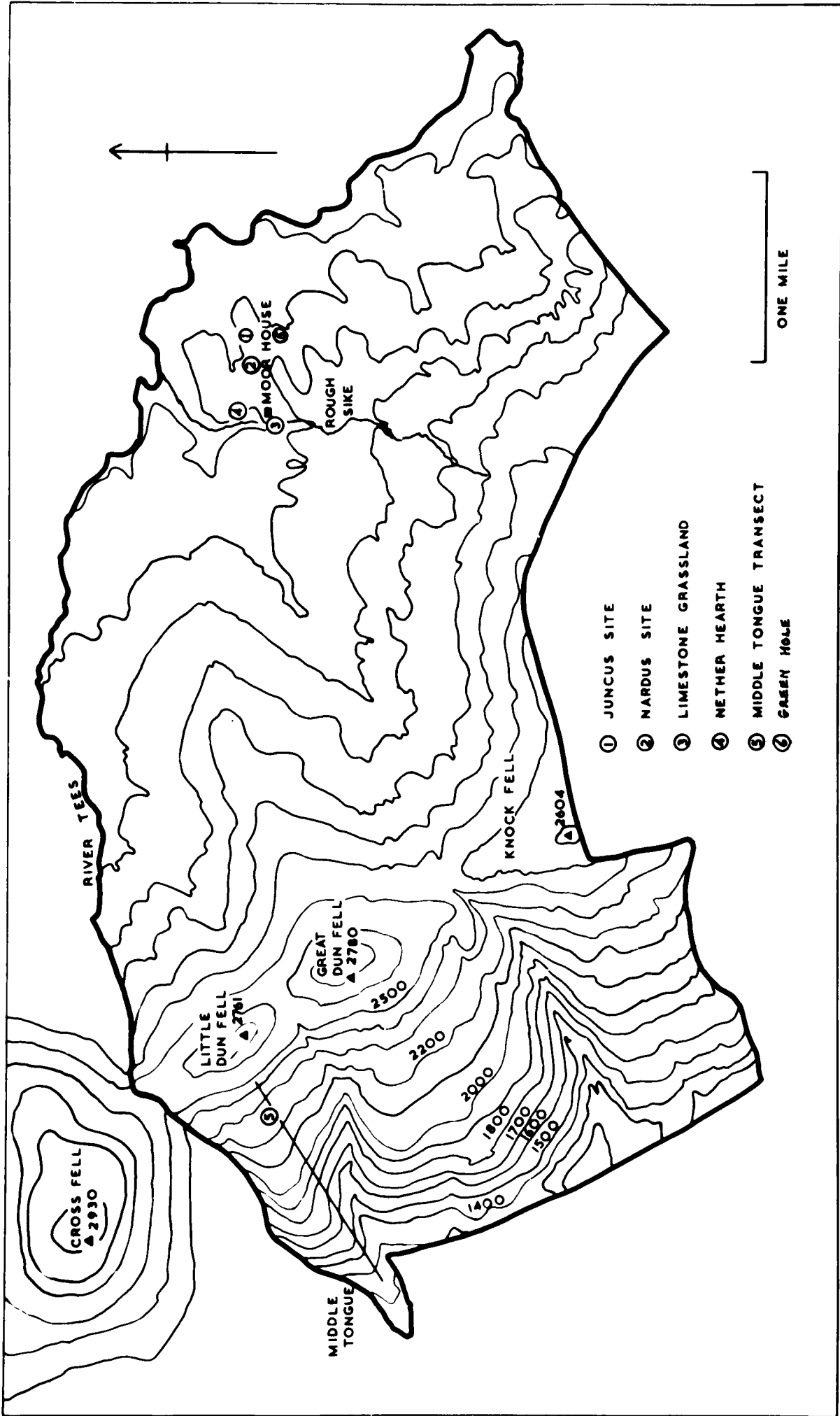

Domin Scale :

x = Isolated, cover small	6 = 25 - 33% cover
1 = Scarce, cover small	7 = 33 - 50% cover
2 = Very scattered, cover small	8 = 50 - 75% cover
3 = Scattered, cover small	9 = > 75% cover
4 = Abundant, 5% cover	10 = 100% cover
5 = Abundant, 20% cover	

In the following account of the host plants of N. lineatus on this site, all fine leaved grasses are grouped together and referred to as Festuca. As the above table shows, a small proportion of this may be Deschampsia which is virtually indistinguishable from Festuca when not in flower.

A grid was established on a Juncus site to the north-west of Great Dodgen Pot Sike (Fig. 1) in order to study N. lineatus nymphs in 1961 and 1962.

b) THE NARDUS SITE (1,800 feet; 549 m.) PLATE 2.

On well leached mineral soils and re-distributed peat, Nardus stricta is a common constituent of the flora and covers considerable areas on the dip-slopes of the Pennine peaks. A representative site was selected at the side of the Bog End track (Fig. 1), approximately mid-way between the house and the end of the track. Nardus stricta is dominant but is associated with some Juncus squarrosus, Deschampsia flexuosa and Carex spp. A grid was established here in order to sample nymphs of N. lineatus in 1961 and 1962.

PLATE 3. THE LIMESTONE GRASSLAND SITE.

A. General view of the grid.

**B. Detail of the vegetation with a quadrat
(1/10 m²) in position.**

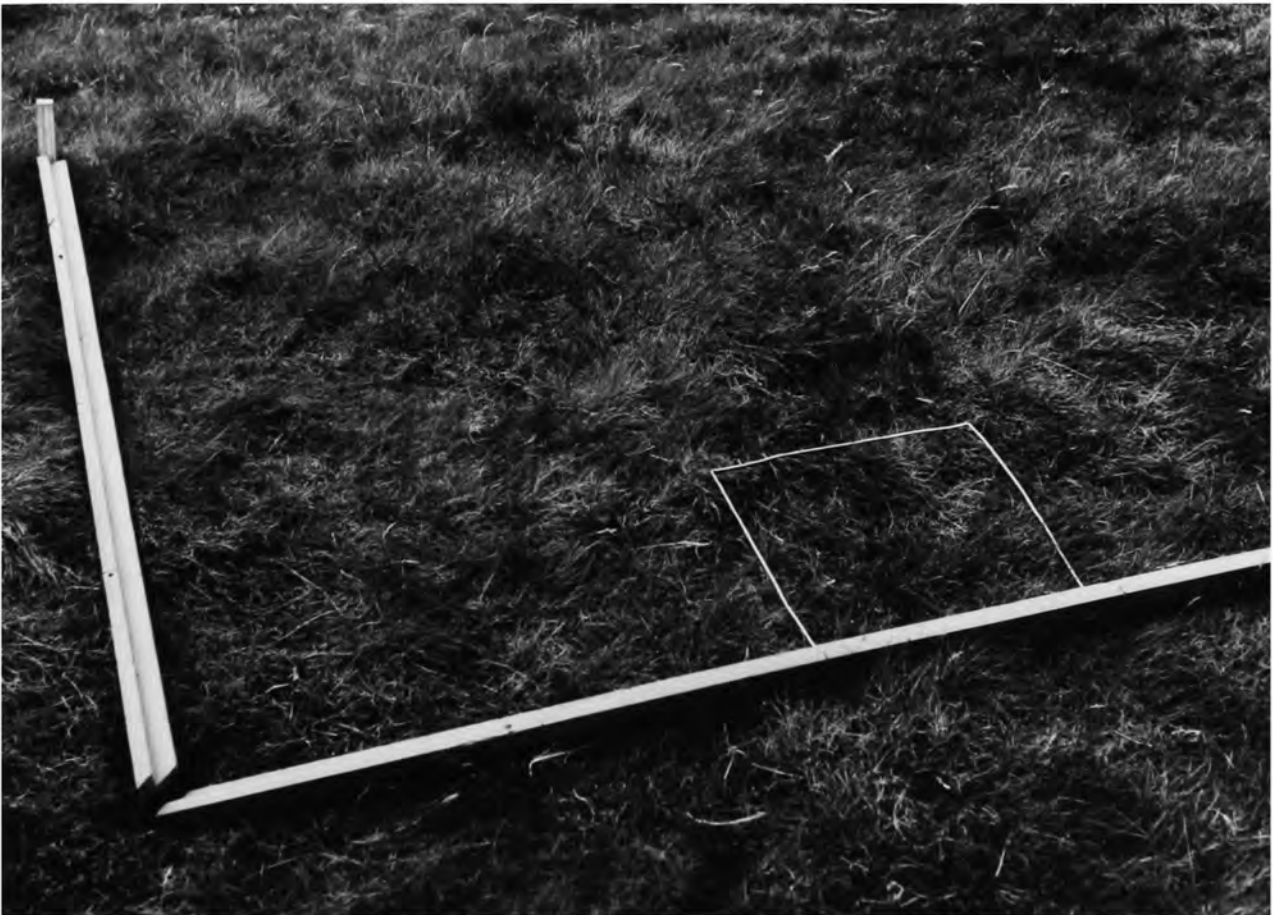

c) THE LIMESTONE GRASSLAND SITE (1,825 feet; 556 m.) PLATE 3.

Although at least 70 per cent of the area of the Reserve is covered by deposits of blanket peat, there are small areas, particularly along the banks of streams, where mineral soil has accumulated. The summit ridge of the Pennines also has similar deposits. On these areas a grassland in which Festuca and Agrostis predominate is found. At the foot of Rough Sike (Fig. 1), an area of Tyne Bottom Limestone is overlaid by mineral soil supporting such a grassland. Approximately one half of this area has an even deposit of soil and this was chosen for the establishment of a grid on which to sample N. exclamatoris nymphs in 1962. A Braun-Blanquet analysis of the area is shown in Table 2. The area is very well drained and the soil is base-rich.

TABLE 2. BRAUN-BLANQUET ANALYSIS OF THE LIMESTONE GRASSLAND SITE
VEGETATION

	A	B	C
<i>Agrostis tenuis</i>	2	2	x
<i>Festuca ovina</i>	3	2	3
<i>Festuca rubra</i>	-	2	-
<i>Achillea millefolium</i>	2	2	-
<i>Carex caryophylla</i>	-	2	-
<i>Luzula campestris</i>	1	x	-
<i>Thymus drucei</i>	2	3	-
<i>Trifolium repens</i>	1	x	-

Braun-Blanquet scale :

x = Isolated, cover small

1 = Plentiful, but of poor cover value

2 = Very numerous or covering at least 5%

3 = Any number of individuals. Cover 25 - 50%

TABLE 3. DOMIN ANALYSIS OF HUMMOCK AND HOLLOW VEGETATION
ON LIMESTONE GRASSLAND

Plant Species	Hummock quadrats				Hollow quadrats					
	1	2	3	4	1	2	3	4	5	6
<i>Agrostis tenuis</i>	4	4	5	5	7	1	4	6	6	7
<i>Anthoxanthum odoratum</i>	-	-	-	1	-	2	-	2	3	-
<i>Festuca ovina</i>	6	8	7	7	6	8	8	7	3	6
<i>Festuca rubra</i>	3	-	3	2	-	-	2	5	7	6
<i>Carex caryophylla</i>	-	3	2	3	-	-	-	-	2	-
<i>Luzula campestris</i>	3	3	2	3	3	2	2	3	2	-
<i>Achillea millefolium</i>	3	-	3	3	-	-	-	-	3	2
<i>Euphrasia nemorosa</i>	3	2	1	2	-	-	-	1	-	-
<i>Galium hercynicum</i>	-	-	-	-	3	2	5	3	2	3
<i>Galium pumilum</i>	3	3	4	4	-	-	-	-	-	-
<i>Plantago lanceolata</i>	-	-	-	-	2	-	-	-	4	-
<i>Potentilla erecta</i>	-	-	-	-	3	3	3	3	-	-
<i>Thymus drucei</i>	6	x	4	5	3	5	-	-	2	3
<i>Trifolium repens</i>	3	3	-	3	3	-	-	-	2	2

The other half of the limestone grassland area is made up of a regular system of hummocks and hollows formed by the existence of upstanding blocks of limestone divided by grikes. In the latter the soil is deeper, but less well drained than on the hummocks. This gives rise to a marked difference in the vegetation, although a quadrat analysis of the hummocks and hollows suggests that the difference is more qualitative than quantitative (Table 3). There is, however, more Agrostis tenuis and Anthoxanthum odoratum in the hollows than on the hummocks and certain herbs are restricted to one or other of the two habitats. The commoner species are listed in Table 3 and are classified by the Domin scale of abundance.

The physical features of these hummocks and hollows are discussed in section V.

d) THE DORTH GILL TRANSECT

In 1961, a transect on the eastern facing slopes to the north of the Reserve at Hill Farm was sampled for N. lineatus nymphs. The transect rose from the bridge across Dorth Gill (1,500 feet; 457 m.) to the summit of the ridge above at 2,000 feet (610 m.). Juncus squarrosus was the dominant plant at each of the six stations at 100 feet vertical intervals up this transect.

e) THE MIDDLE TONGUE TRANSECT

The steep western escarpment of the Reserve falls steadily from the summit of Little Dun Fell (2,761 feet; 842 m.) down a triangle of land bounded by Crowdundle and Middle Tongue becks known as Middle

Tongue. A transect from 1,250 feet (381 m.) up to 2,250 feet (686 m.) with stations at 250 foot vertical intervals was sampled in 1962.

Each of the stations had Juncus squarrosus as the dominant member of the flora and nymphs of N. lineatus were sampled on this transect up to 2,250 feet, beyond which they became too sparse for quantitative work. Each of the stations had the same aspect and the slope of the transect was constant, so that samples from each of the stations would be mainly affected by the altitude at which they were taken.

f) OTHER SAMPLE SITES

In addition to the above mentioned sites, sweep net samples were periodically taken on the following vegetation types :

i. Actively growing bog known as Valley Bog (Fig. 1). An area characterized by Sphagnum and Eriophorum and small tufts of Calluna. In spite of repeated sweeping, the area yielded few Auchenorrhyncha.

ii. Mixed Moor. Areas where peat erosion is taking place and the dominant flora consists of Calluna, Cladonia and Eriophorum.

Although covering very large areas of the Reserve, this habitat is poor in species of Auchenorrhyncha.

iii. Base-rich grassland. In a well drained hollow, known as Green Hole, near to the source of Great Dodgen Pot Sike (Fig. 1), Deschampsia and Holcus form much richer grassland than elsewhere on the Reserve, with the exception of a cultivated meadow adjacent to the house (the paddock).

- iv. Urtica dioica, Common around the house.
- v. Pteridium aquilinum, Abundant on Middle Tongue.
- vi. Carex rostrata standing in a stagnant pool at Bog End.
- vii. Juncus effusus on alluvial soils and in flushes.

3. THE CLIMATE AT MOOR HOUSE

The Reserve lies on the "Alston block"; the highest part of the Pennine upland and the most consistently elevated region in England. It is not therefore surprising that the climate is severe, with a high number of rain days each year resulting in an average annual rainfall of over 70 inches. The average summer and winter temperatures of 55°F (12.8°C) and 29.3°F (-1.7°C) respectively are low, and strong winds are common throughout the year. (Based on a ten year record by Manley, 1943). Some mean temperatures recorded at Moor House and on the summit of Great Dun Fell are taken from Manley (1942, 1943) and are recorded in Table 4. A summary of 1961 and 1962 conditions have been extracted from the Nature Conservancy's records and are shown in Table 5, where they are compared with average figures over the 1953-62 period.

TABLE 4. MEAN JANUARY AND JULY TEMPERATURES AT MOOR HOUSE AND GREAT DUN FELL.

	Altitude (feet)	Mean temp. °C.	
		Jan.	July
Moor House	1,840	0.6	11.7
Dun Fell	2,735	-1.7	9.4

Perhaps the most significant feature of the temperature records is the existence on many evenings of a rapid fall followed by marked fluctuations. Diurnal ranges of up to 40^oF have been recorded. Snow may lie on the ground until mid-May and frost has occurred in every month of the year. Moor House may therefore be said to be typical of the montane zone of Britain which has been described as having features comparable to those at sea level in Iceland (Manley 1936).

TABLE 5. SUMMARY OF MOOR HOUSE METEOROLOGICAL DATA 1961 AND 1962 COMPARED WITH THE TEN YEAR AVERAGE (1953-62)

	1961	1962	Average 1953-62
Mean maximum temperature ^o C	8.6	7.5	8.6
Mean minimum temperature ^o C	2.5	1.1	1.9
$\frac{1}{2}$ (Maximum + minimum) temperature ^o C	5.6	4.3	5.2
Rainfall, inches	78.4	77.0	74.8
Number of rain days	241	251	245
Days with snow lying	55	79	58
Average daily sunshine, hours	2.8	2.9	3.2
Mean monthly wind speed, knots	11.5	13.2	-

Manley (1936 and 1943) has described the climate of the area in some detail and his figures for monthly maxima and minima over a ten year period are recorded in Table 6.

TABLE 6. MEAN MAXIMUM AND MINIMUM TEMPERATURES AT MOOR HOUSE
1932 - 1942 (FROM MANLEY 1943)

Month	Mean daily maximum °C.	Mean daily minimum °C.	Average °C.
J.	2.6	-1.4	0.6
F.	2.6	-1.9	0.3
M.	3.8	-1.5	1.2
A.	6.7	-0.1	3.3
M.	11.0	3.1	7.1
J.	13.9	5.4	9.7
J.	15.3	7.8	11.6
A.	14.8	7.8	11.3
S.	12.4	5.7	9.1
O.	8.5	2.8	5.7
N.	4.7	0.2	2.4
D.	2.9	-0.8	1.1
Year	8.3	2.3	5.3

III. TAXONOMY AND AUTECOLOGY OF THE MOOR HOUSE AUCHENORRHYNCHA

1. TAXONOMY

a) GENERAL

The naming of British Auchenorrhynchos Homoptera is still in a state of flux because of the activities of Continental and American workers who are introducing nomenclatorial changes as the old type collections are re-studied. The only available British key for the group (except for a Royal Entomological Society handbook on the Fulgoromorpha - Le Quesne 1960) is the 1896 publication of J. Edwards, "THE HEMIPTERA - HOMOPTERA OF THE BRITISH ISLANDS". It has, however, to be used with caution because few of his names remain unchanged and many of his genera have been split. Preliminary identifications were made with this key, but these have been checked and the names corrected by reference to the extensive key for European Jassidae (Cicadellidae) by Ribaut (1952). This was made necessary by the importance placed on the colour markings in the Edwards key, and the great variability of these in the Moor House species. Ribaut's key is based mainly on genitalia characteristics, particularly the form of the penis. For examination of the latter, the last few segments of the abdomen were heated in 3 per cent potassium hydroxide. The penis was then dissected out and mounted in gum tragacanth on Bristol board. Identifications of the Cercopidae were checked with the key in Svenska Insektfauna (Ossiannilsson 1946-47). Delphacidae (Fulgoromorpha)

were identified with the Royal Entomological Society key (Le Quesne 1960). No descriptions of immature Cicadellidae are available but certain immature Delphacidae have been described and keyed by Hassan (1939). The check list of China (1950, 1951) is utilised in naming the species in the present account and all identifications have been checked by comparison with specimens in the British Museum (Natural History).

With existing keys, it was only found possible to determine the specific status of Psammotettix striatus by a preparation of the male genitalia. The shape of the penis differentiates this species from P. confinis and P. putoni, which do not appear to occur at Moor House. Similarly, it proved difficult to decide whether the species of Macrosteles occurring on Juncus squarrosus was M. sexnotatus (Fallén 1806), M. horvathi (Wagner, W. 1935), M. fieberi (Edwards, J. 1891), M. frontalis (Scott 1875), or M. viridigriseus (Edwards, J. 1924), without dissection. The latter three species can normally be distinguished because the head markings are confluent. In many Moor House specimens of M. sexnotatus, however, the dark pigments are excessively developed and often appear confluent. Dissections showed that they are abnormally dark specimens of M. sexnotatus which is easily distinguished from the other species by the shape of the penis.

In general it may be said that there is a greater than usual tendency towards the production of dark pigments in the Moor House Auchenorrhyncha, making their identification difficult. Thus, almost all the specimens of Tettigella viridis taken on the Reserve were of the

dark variety suffusa, and an entirely black specimen of Neophilaenus exclamationis has been taken. The tendency for insects to develop dark pigments at high altitudes or latitudes has been recorded before (e.g. Benson 1950). He is of the opinion that melanic forms are more characteristic of high humidities than low temperatures. The dark forms at Moor House were found in marshy places, but also at high altitudes. The effect of low temperatures on dark pigment production is complex, because although they tend to inhibit pterine production thus leading to the occurrence of pale forms in the north or on mountain tops (Hovanitz 1941), yet there are many examples of low temperatures producing dark forms (Wigglesworth 1953). The reason for the occurrence of dark forms at Moor House is therefore obscure. Another characteristic of high altitude Auchenorrhyncha is the common occurrence of brachypterous forms. In fact in species which are known to exhibit macropterous and brachypterous forms, the former have been taken only in the paddock area or at low altitudes on Middle Tongue. Thus all the Delphacidae collected were brachypterous with the exception of some macropterous Delphacodes pellucida from the paddock (this species is brachypterous elsewhere on the Reserve), and Kelisia vitipennis from Middle Tongue. All the Delphacidae on the Reserve are known to have macropterous forms in other parts of their range.

In his study of Plecoptera, Hynes (1941) came to the conclusion that brachyptery is probably not an effect of temperature, because he claimed that there is no evidence that latitude has any influence on

the length of wings. Brinkhurst (1959), however, points out that a number of workers have established that wing polymorphism is commoner in northern latitudes (e.g. Lindberg 1929, Jordan 1943) and at higher altitudes (Teyrovsky 1952). Hynes (1955) collected more apterous Heteroptera at high altitudes. The significance of alary polymorphism is still open to doubt. Hynes (1941) and Brinck (1949) suggest that it may be an advantage to stoneflies in open mountainous districts because insects with reduced wings are less likely to be carried away by high winds. On the other hand, Ekblom (1941) presented data which demonstrates that short winged forms of Gerris (Heteroptera) are more cold resistant than long winged forms. Either of these theories would fit the Moor House situation, but the second seems most likely because flight is rare even in macropterous Auchenorrhyncha. In the following section on autecology, distinction is made between brachypterous individuals in which the wings are much reduced, and sub-macropterous forms in which the wings are only a little shorter than in normal specimens of the group.

b) THE CERCOPIDAE

Although almost all the species named in this account have several synonyms, some special mention must be made of the naming of Philaenus spumarius, because the International Commission on Zoological Nomenclature has recently made a ruling which invalidates the name used by American authors. Most recent papers on this species have used the name P. leucophthalmus based on the opinion of Horvath (1898), who concluded that the insect described originally by Linnaeus as

P. spumarius was in reality Aphrophoraalni (which therefore becomes Aphrophora spumaria). Thus P. spumarius should be known as P. leucophthalmus (Linnaeus 1758) which is the next name in order of preference. American authors have accepted this, but the International Commission have recently decided to interpret the identity of Cicada (= Philaenus Stål 1854) spumaria Linnaeus 1758 as identical with Cicada leucophthalmus Linnaeus 1758, following a recommendation by Ossiannilsson (1957). Much of this confusion arises because of the occurrence of several colour varieties of P. spumarius which have in the past been described as distinct species. The naming of the colour varieties in the present study is according to the illustrations given by Halkka (1962), in order that data on their frequency may be comparable with his.

The two species of Neophilaenus discussed have in the past been referred to the genera Cicada De Geer, Philaenus (Stål 1864) and Ptyelus Flor, before the erection of the genus Neophilaenus by Haupt in 1905.

2. CHECK LIST OF MOOR HOUSE AUCHENORRHYNCHA

The species are named and arranged according to the check list of China (1950, 1951).

SUPERFAMILY CICADOIDEA

FAMILY CERCOPIDAE

Philaenus Stål 1864

1. spumarius (Linnaeus 1758)

Neophilaenus Haupt 1905

2. lineatus (Linnaeus 1758)
3. exclamationis (Thunberg 1784)

FAMILY CICADELLIDAE

Ulopa Fallén 1814

4. reticulata (Fabricius 1794)

Tettigella China and Fennah 1945

5. viridis (Linnaeus 1758)

Oncopsis Burmeister 1837

6. tristis (Zetterstedt 1840)

Aphrodes Curtis 1831

7. bifasciatus (Linnaeus 1758)

Deltocephalus Burmeister 1838

8. pulicaris (Fallén 1803)

Arocephalus Ribaut 1946

9. punctum (Flor 1861)

Jassargus Zachvatkin 1934

10. pseudocellaris (Flor 1861)

Diplocolenus Ribaut 1946

11. abdominalis (Fabricius 1803)

Psammotettix Haupt 1929

12. striatus (Linnaeus 1758)

Scleroracus Van Duzee 1894

13. sp. (female only)

Euscellis Brullé 183214. obsoletus (Kirschbaum 1868)Streptanus Ribaut 194215. sordidus (Zetterstedt 1828)16. marginatus (Kirschbaum 1858)Macustus Ribaut 194217. grisescens (Zetterstedt 1820)Cicadula Zetterstedt 183818. quadrinotata (Fabricius 1794)19. intermedia (Boheman 1845)20. frontalis (Herrich - Schaeffer
1835)Macrosteles Fieber 186621. sexnotatus (Fallén 1806)Cicadella Dumeril 180622. notata (Curtis 1837)23. urticae (Fabricius 1803)24. aurata (Linnaeus 1758)Dikraneura Hardy, J. 185025. sp. (female only)

FAMILY DELPHACIDAE

Megamelus Fieber 186626. notula (Germar 1830)Kelisia Fieber 186627. vittipennis (Sahlberg, J. 1867)

Conomelus Fieber 186628. anceps (Germar 1821)Calligypona Sahlberg, J. 187129. discolor (Boheman 1847)30. pellucida (Fabricius 1794)31. brevipennis (Boheman 1847)Criomorpus Curtis 183132. sp. (damaged)

3. AUTECOLOGY OF THE MOOR HOUSE AUCHENORRHYNCHA

FAMILY CERCOPIDAE

1. Philaenus spumarius

Present only along the lower fringe of the paddock area. Nymphs from early June to late August and adults from August to September. Seven colour varieties of the adults have been taken at Moor House.

2. Neophilaenus lineatus

Common on Juncus and Nardus areas up to 2,700 feet. Nymphs from late May to late July. Adults from July to October.

3. Neophilaenus exclamationis

Common on Festuca / Agrostis grassland only. Distinguished from the previous species by its smaller size and the presence of an " ! " mark along the costal margin of the elytra. Nymphs from May to July, adults from July to October.

FAMILY CICADELLIDAE

4. Ulopa reticulata

A hardy species found on, and around the roots of Calluna. Nymphs and adults are found throughout the year at Moor House.

5. Tettigella viridis

Only taken on the west side of the Reserve at altitudes below 1,300 feet on Middle Tongue. The species is easily taken by sweeping Juncus effusus in September (nymphs and adults) and October (adults). The dark variety suffusa is common.

6. Oncopsis tristis

Only one specimen has been taken on birch in Green Hole. These trees were introduced to the Reserve in 1954. It is the only arboreal species which has been taken on the Reserve.

7. Aphrodes bifasciatus

Taken sparingly on Festuca /Agrostis grassland in August and September. Rarely taken by sweeping although it is not uncommon in vacuum samples and therefore probably inhabits vegetation very near to the ground surface. Although not taken higher than 1,850 feet at Moor House, specimens have been collected by the writer at 2,700 feet on Blencathra (English Lake District). The species exhibits marked sexual dimorphism; only the males having distinctive markings on the elytra.

8. Deltocephalus pulicaris

Fairly common on Festuca / Agrostis grassland in August and commonly taken from the fine leaved grasses under bracken on Middle Tongue.

9. Arocephalus punctum

Very common on Deschampsia in Green Hole in August.

10. Jassargus pseudocellaris

Fairly common on Nardus in August and September and has been taken rarely on Deschampsia, Juncus squarrosus and on the fine grass under bracken on Middle Tongue.

11. Diplocolenus abdominalis

Common on Holcus, Nardus and Juncus squarrosus from early July to late October. One of the most abundant Cicadellidae at Moor House. Most specimens are sub-macropterous.

12. Psammotettix striatus

Very common on Festuca / Agrostis grassland from late July to October.

13. Scleroracrus sp.

A single female referable to this genus has been taken by sweeping Calluna in July on Knock Fell. It has not been possible to determine

whether the specimen is S. striatulus or S. russeolus, because females of these two species are indistinguishable.

14. Euscelis obsoletus

Fairly common on Juncus effusus in August and September. A specimen carrying the cyst of a dryinid (Hymenoptera) parasite was taken in October 1960.

15. Streptanus sordidus

Common in long, damp grass (Green Hole and Paddock) and also on Nardus from late August to October.

16. Streptanus marginatus

Overwinters as a late instar nymph and adults appear in the population in June on mixed moor. Brachypterous.

17. Macustus grisescens

Common on Juncus effusus in wet flushes from June to August.

18. Cicadula quadrinotata

Fairly common on Nardus and in valley bog in August and September. In both cases it is probably associated with Carex species.

19. Cicadula intermedia

Common on Carex rostrata growing in stagnant pools and also taken on Juncus effusus. Nymphs from mid-July to early August. Adults

August to October.

20. Cicadula frontalis

Fairly common on Juncus effusus on Middle Tongue up to about 1,200 feet. August and September.

21. Macrosteles sexnotatus

Very common on Juncus squarrosus and Nardus in August and September. Also taken in valley bog and on Juncus effusus and may even extend on to the mixed moor. Nymphs in July and August.

22. Cicadella notata

Taken sparingly on the Festuca / Agrostis hummocks in August.

23. Cicadella urticae

Extremely abundant on Urtica dioica in August.

24. Cicadella aurata

Taken rarely on Urtica in company with C. urticae.

25. Dikraneura sp.

Rare on marshy areas in Green Hole and on Middle Tongue, in September.

FAMILY DELPHACIDAE

26. Megamelus notula

On Carex rostrata and Juncus effusus in very damp places.

Adults from June to September.

27. Kelisia vittipennis

On Juncus effusus up to about 1,200 feet on Middle Tongue in September. Specimens taken were macropterous, and with the exception of some Calligypona pellucida from the paddock, were the only macropterous Delphacidae found on the Reserve.

28. Conomelus anceps

Very common on Juncus squarrosus where densities of over 1,000 nymphs / m² have been recorded in mid-June and over 50 adults / m² in early September. The most abundant delphacid at Moor House.

29. Calligypona discolor

Taken sparingly on Juncus squarrosus in July.

30. Calligypona pellucida

Common in the paddock, Green Hole and on Nardus and Juncus squarrosus, in August. Several specimens stylopised. All brachypterous with the exception of those from the paddock which were macropterous. Overwinters as the nymph.

31. Calligypona brevipennis

Uncommon on Juncus effusus below about 1,200 feet on Middle Tongue in August.

32. Criomorphus sp.

Only one specimen taken on Juncus effusus in August.

4. PARASITES OF MOOR HOUSE AUCHENORRHYNCHA

The recorded parasites of Homoptera (e.g. Perkins 1905) are usually easily observed because they often result in the development of large cysts on the body of the host. Examination of 1,011 specimens of N. exclamationis and 178 of N. lineatus showed no external signs of parasitism. Many were also dissected but no parasites were found. Similarly, 292 Psammotettix striatus and 190 Macrosteles sexnotatus had no external sign of parasitism. There are some species of Cicadellidae which do have parasite cysts at Moor House, however. Dryinid cysts, which are usually inserted between the prothoracic sternite and the head of the host, have been observed in Cicadula quadrinotata (in one female host), Diplocolenus abdominalis (in one male), Euscelis obsoletus (in one female) and Jassargus pseudocellaris (in one female). Such records are rare, however. Amongst the Delphacidae, 692 Conomelus anceps examined included only one parasitized specimen, but stylopedicel individuals of Calligypona pellucida have been found. From the descriptions of Hassan (1939), a male strepsipteran preserved in the act of emerging from the puparium

in the abdomen of a castrated Calligypona pellucida has been identified as Elenchus tenuicornis (Kirby 1815).

Parasites were thus extremely rare or absent in each of the species for which population counts have been made, although present in small numbers in several of the other species of Auchenorrhyncha at Moor House. These were not collected in sufficient numbers for reliable estimates to be made of the percentage parasitised.

5. AFFINITIES OF THE MOOR HOUSE AUCHENORRHYNCHA

Cragg (1961) has pointed out that the study of whole groups of the Moor House fauna has emphasized the importance of the Scandinavian and sub-arctic element in the fauna. Thus Cherrett (1961) describes the spider fauna as similar to Iceland (sub-arctic) whilst Coulson (1959) and Hale (in Cragg 1961) describe the Tipulidae and Collembola respectively as comparable with the upland fauna of northern Scandinavia.

The most obvious characteristic of the Auchenorrhyncha at Moor House is the extreme paucity of species. Although 340 species are listed by China (1950) for Britain, only 32 have been taken on the Reserve, and of these, nine are only taken rarely. By far the greatest area of the Reserve is covered by mixed moor and yet only three species have been taken on this vegetation type.

An examination of *Catalogus Insectorum Sueciae VIII* (Ossiannilsson 1948) has shown a close comparison between the Cercopidae and Cicadellidae of Moor House and northern Sweden. There

are 27 Cercopidae and Cicadellidae recorded from an inland elevated area at 65°N in Sweden known as Åsele Lappmark. Only 11 of these do not occur at Moor House and 6 of these do not occur in Britain. Of the remaining 5, four are only taken on bushes and trees (the trees at Moor House have only been planted since 1954) and the other is rare in Britain. The cercopid species are the same in the two areas. Thus excluding the tree living species, some 70 per cent of the Åsele Lappmark species occur at Moor House. This agrees with Cragg's general comparison of the area with the sub-arctic.

IV. SAMPLING TECHNIQUES

1. QUANTITATIVE SAMPLING OF CERCOPID NYMPHS

a) INTRODUCTION

Methods described in the literature for estimating the densities of Cercopidae, are restricted to species of economic importance.

Four principal methods have been used, viz:

- 1) Estimations of percentage infested stems.
- 2) " " spittle masses per unit area.
- 3) " " number of nymphs per stem.
- 4) " " number of nymphs per unit area.

Chamberlin and Medler (1950) and Ahmed et al (1952), in their studies of Philaenus spumarius, have used the percentage of infested stems of the host plants as an index of the population density. The former authors point out the disadvantages of this method and suggest that the number of infested stems times the average number of nymphs per infested stem would be a better measure. Pickles (1934) in his study of the sugar-cane froghopper (Tomaspis saccharina Dist.) used a variant of this second method in which he recorded the mean number of nymphs from the sugar-cane stools. Although these methods allow rough comparisons of population densities to be made, they do not give an accurate estimate of the number of nymphs occurring per unit area. Marshall and Gyrisco (1951) attempted to do this in a study of P. spumarius by examining three areas one yard square, chosen at random, and recording the number of spittle masses. Weaver and

King (1954) point out an error in this method caused by the tendency of nymphs to aggregate within spittle masses. This they attribute to overcrowding in high infestations. It will later be shown, however, (section VI) that this habit occurs even in low density populations in the species examined. These methods were therefore rejected in the present study in favour of the fourth possibility, the estimation of numbers of nymphs per unit area. Wilson and Davies (1953) counted nymphs in random foot square areas but give no indication of their methods.

Because of the relatively sessile nature of the nymphs and their habit of making themselves conspicuous by production of spittle, a quadrat system of sampling was employed in the present study. This was feasible because the vegetation on the sites sampled did not exceed 30 cm. in height and was usually much less.

b) PRELIMINARY SAMPLING

When spittles were first observed at the beginning of the 1961 season (on May 15), a number of randomly placed quadrats were thrown to determine the approximate population density, so that a practical quadrat size could be established. As a result of this, a 1/20 metre square quadrat was decided upon because a much bigger quadrat would be difficult to search efficiently, and a much smaller quadrat would have to be thrown a very large number of times in order to give a good estimate of the numbers present. It was estimated that 40 quadrats 1/20 metre square provided the best balance between accuracy

on the one hand, and economy of labour on the other.

The sampling at first took the form of a count of all spittles lying within quadrats which were positioned simply by a random throw. The spittles could not, however, be removed without destroying a part of the population under study and so a practice was made of collecting 50 spittles for laboratory examination from an area adjacent to that being sampled, so that the spittle:nymph ratio could be determined and the instars identified.

A check was made to see if there was any bias in such a method towards collecting only the most obvious spittles, which often contain the later instars. Table 7 compares the instar composition of a "random" sample collected by taking the first 50 spittles found, and a sample collected by throwing quadrats and removing all the spittles so enclosed, until a total of 50 was reached.

TABLE 7. COMPARISON OF THE INSTAR COMPOSITION OF QUADRAT SAMPLES AND RANDOM SAMPLES.

	Quadrats	"Random"	Total
1st Instars	31	19	50
2nd Instars	21	31	52
Total	52	50	102

$$\chi^2 = 3.94 \text{ with one degree of freedom, } P < 0.05$$

There is an obvious bias in the "random" method of collection towards taking a disproportionate number of later nymphs.

After such preliminary sampling it was decided to construct a grid system to facilitate sampling and allow quadrats to be denuded of spittles after they had been surveyed.

c) GRID SAMPLING

On each of the sites to be sampled, a grid system of contiguous quadrats (Macfadyen 1957) was pegged out so that at a rate of 40 quadrats (1/20 metre square) on each sampling date, the grid would be ample for the whole nymphal season. Thus on the Juncus site grid, over 1,000 quadrats were available. Each quadrat was denoted by a four unit reference as in Fig. 2. The extreme upper left quadrat would thus be named A_1a_1 . The quadrats were randomly selected by drawing referenced cards out of a container. By this means no quadrat was sampled twice, and the withdrawn cards acted as a check on those quadrats already sampled.

The exact position of a quadrat on the grid was located by placing canes in position to complete two sides of one of the major squares (e.g. A_1). Notches on the canes allowed exact placing of a 1/20 metre square wire quadrat on one of the minor squares of the grid (e.g. a_1). See Plate 3.

With the quadrat in position, a systematic search was made for all the spittles within it and as these were found they were removed and placed in numbered tubes - one for each quadrat. Although some spittles were easily seen, others were only found by careful searching. Only nymphs which were not feeding and had left their

FIG. 2 THE LAYOUT OF THE SAMPLE GRIDS

Reference pegs were placed at two corners
of each of the major squares, which enclose
16 quadrats, each $1/20$ metre square.

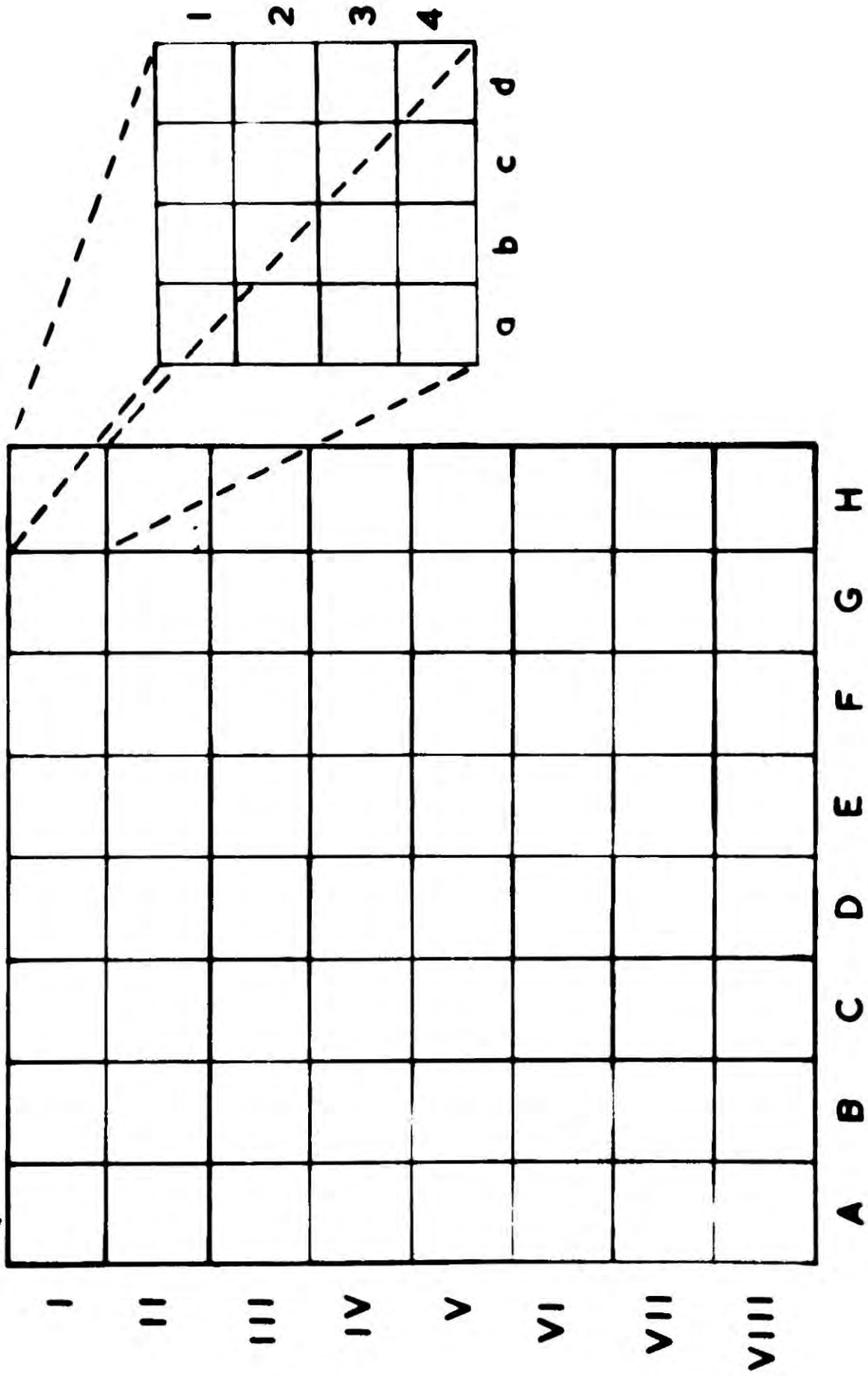

spittle would, however, be missed in the count, and these represent a very small part of the total present (see later).

The numbers of spittles per quadrat were recorded in the field, but the numbers of nymphs per quadrat were examined in the laboratory where preliminary separation into instars could be made according to the characters described by Garman (1921). All the nymphs collected in this way were preserved for future study.

In 1961, the Juncus site was sampled in this way usually every three days, whilst the Nardus site was sampled at approximately six day intervals. In 1962, however, the introduction of sampling of the Limestone Grassland and the smaller populations made it necessary to sample on approximately every five days on each site.

d) ERRORS IN THE GRID SAMPLING

i. Destruction of spittles by the observer.

Repeated movements of an observer on a grid may destroy spittles and carry nymphs out of the study area. This was minimized by examining the quadrats in order of position on the grid and not in the order in which they were drawn.

Two tests were carried out to ascertain the amount of destruction of the spittles in this way :

The number of spittles per square metre was examined on an undisturbed area immediately adjacent to the grid, for comparison with the numbers on the grid. This test was repeated on three occasions during the nymphal season and the results are shown in Table 8.

TABLE 8. COMPARISON OF DENSITIES OF SPITTLES ON THE SAMPLING GRID AND ON AN ADJACENT UNDISTURBED AREA

Date	A	B	A - B
	No./m ² on grid + S.E.	No./m ² off grid + S.E.	S.E. of difference
21 June 61.	40.0 ± 5.6	38.0 ± 6.0	+ 2.0 ± 8.2
3 July 61.	32.0 ± 5.0	34.0 ± 7.6	- 2.0 ± 9.2
18 July 61.	13.0 ± 3.0	16.0 ± 4.6	- 3.0 ± 5.4

The numbers per metre square on the grid are not significantly different from those on the undisturbed area.

An area containing a known number of mapped spittles was systematically trampled ten times. The number of spittles remaining was then recorded. In all, 58 spittles were mapped and after the trampling 52 remained (10% lost). This probably represents a higher error than is in fact the case, because there is no evidence that the six nymphs were killed or removed from the study area. They may simply have been brushed out of the spittle into the vegetation and temporarily lost until they formed new spittle. Errors introduced by movement of the observer are therefore small.

ii. Migrating nymphs or very small spittles.

Possible errors introduced by nymphs being missed in the count were estimated by re-examining quadrats on the two days after they had been denuded in the course of the sampling. In all, 40 quadrats were re-examined and these had initially yielded 79 nymphs when first

examined. A further 7 nymphs were found on the re-examination, representing a possible 9 per cent error in the original sample (Table 9). It is not possible to say whether this error is due to nymphs which were present in the quadrats but were overlooked, or nymphs which had migrated in to the quadrats from adjacent ones.

TABLE 9. ESTIMATION OF SAMPLING ERROR BY RE-EXAMINATION OF QUADRATS

Dates (1961)	No. of quadrats re-examined	No. of nymphs at re-exam- ination	No. of nymphs in original sample
18-20 June	20	4	40
20-23 June	10	2	26
30 June - 2 July	10	1	13
Totals	40	7	79

Error = 9%

iii. Relative efficiency of sampling instars.

From the second instar onwards, N. lineatus produces a considerable quantity of spittle which would be difficult to overlook in the search of the quadrats. It is therefore felt that the error due to failure to find second, third, fourth and fifth instars is very small. (See also sub-section d)(above). First instars, on the other hand, often produce very small quantities of spittle which appear as little more than drops of liquid in the leaf axils of the host. This may easily

be overlooked especially at the base of Juncus squarrosus rosettes, even in a careful search.

On 15 May 1962, 20 quadrats were denuded of instar one nymphs and yielded seven specimens. Then on 18 and 25 May, these quadrats were re-examined and a further 6 instar one nymphs were found. Similarly, 10 quadrats which had yielded 3 instar one individuals on 25 May, gave a further 4 nymphs when re-examined on 29 May. Those found on re-examination could be either nymphs which were present on 25 May but not observed, or nymphs which had hatched after that date. If the former, they would represent a 50 per cent error in the initial sampling, but if the latter, they would represent a continuation of the hatch of such a magnitude as to approximately double the population density by 29 May. If due to inefficiency in sampling instar one, this apparent doubling of the population density would not occur until instar two was being sampled (from 4 June onwards). This was in fact the case, and the apparent population density in 1962 approximately doubled as instar two appeared in the population. It is therefore assumed that the first premise is correct and due to the very small amount of spittle produced, instar one was sampled with approximately only 50 per cent efficiency.

Similarly an examination of the raw data from the Juncus and Nardus sites in 1961 showed a peak in total numbers corresponding with the peak of second instar occurrence (Fig. 15). The proportion of first instars in the population does not rise sufficiently to allow an explanation of this in terms of a further hatch. It is therefore most

likely to be due to an increase in efficiency of sampling as the second instars appear. If it is assumed that only 50 per cent of the first instars are found and the data corrected accordingly, the discrepancy in the population curve is largely removed.

In the absence of other evidence, it has been decided to assume only 50 per cent sampling efficiency of first instar nymphs and the data has been corrected accordingly. Population estimates prior to instar two must therefore be viewed with caution as it is recognised that the figure of 50 per cent is only an approximation.

Further evidence for the validity of this assumption is discussed in section VI. A direct means of checking the efficiency of sampling instar one is not available, but if the figure of 50 per cent is accepted, and the appropriate survival rate calculated using this assumption, this survival rate can be checked by an independent method. This has been done in section VI, and the result suggests that the assumption of 50 per cent efficiency is a reasonable one.

e) EFFECT OF SAMPLING ON THE NEXT YEAR'S POPULATION

The sampling method involved the removal and preservation of nymphs from the study area. It is therefore important to estimate the effect of this on the succeeding generation.

In the whole of the 1961 sampling season, some 1,500 nymphs and 50 adults were removed from the Juncus site. The natural mortality of the nymphs has been calculated (section VI), so that it can be estimated that only 800 of the nymphs removed would have become adult.

Therefore approximately 850 potential adults were removed. The density of adults on the whole site was about $10/m^2$ and the site has a total area of about 500 square metres. Therefore the total population on the Juncus sampling site was 5,000 adults. The 850 potential adults removed thus represent about 17 per cent of the population.

f) ESTIMATION OF POPULATION DENSITY BY PERCENTAGE ABSENCE

If individuals of a species are distributed at random in a population, then the number of quadrats which will contain none, one, two, three etc. individuals can be obtained from the theoretical Poisson distribution. The proportion of quadrats containing no individuals is e^{-m} where m is the mean density per quadrat and e is the exponential. Therefore the percentage absence is $100e^{-m}$.

Svedberg (1922) showed that the logarithm of this expression has a linear relationship to mean density, and this is so even if the individuals in the population are not exactly randomly distributed. (It is simply the slope of the line which is affected) (Blackman 1942). It is therefore possible to use the percentage absence method of estimating populations even if the animals are not randomly distributed.

Methods of sampling cercopid nymphs have already been discussed. In the economic studies in progress in North America, it is usually only necessary to rapidly compare several sites which have for example, been differentially treated with insecticides. It was therefore thought desirable to test the percentage absence method of estimating densities

FIG. 3 THE RELATIONSHIP BETWEEN THE LOGARITHM OF THE PERCENTAGE ABSENCE, AND THE SPITTLE DENSITY ON THE JUNCUS SITE IN 1961.

The regression ($y = 1.982 - 0.0186x$) of the points is shown, together with its confidence limits (broken lines).

REGRESSION OF SPITTLES / M² & % ABSENCE

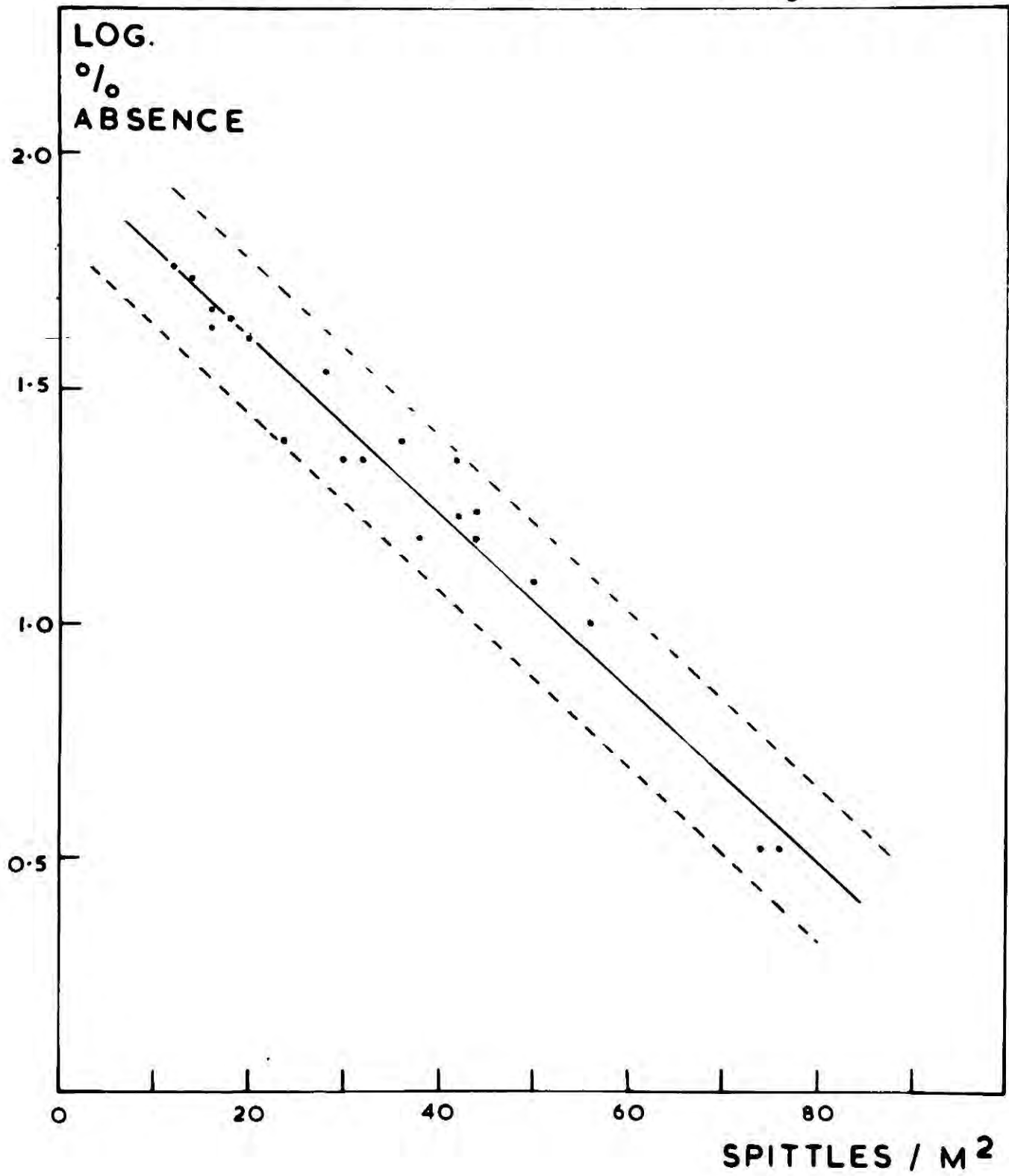

of cercopid nymphs, because it is a rapid (and therefore economical) method.

In Fig. 3 the logarithm of the percentage of empty quadrats found on each date on the Juncus site in 1961 is plotted against the number of spittles per square metre calculated from the mean number of spittles per quadrat. The relationship is linear even though the points have a fair amount of scatter. The continuous line is the calculated regression on these points ($y = 1.982 - 0.0186x$).

To test whether the use of such a regression line would give an adequate estimate of the population compared with that obtained by the much more laborious method of counting the number of spittles per quadrat, numbers per metre square computed from the regression line are compared in Table 10 with those obtained from the count of spittles in each quadrat. The computed figure lies outside the observed figure with its standard error in only two cases (marked *). Thus estimation of population density from a previously calculated regression will usually give an estimate which falls within the limits assessed by quadrat counts. As a further test of the method, the regression line from the 1961 Juncus data was used to estimate the population size of the Nardus site in 1961. The observed and computed values are compared in Table 11. Two of the computed values err considerably but the rest are similar.

It may be concluded that where the cercopid infestations of several similar areas are to be compared, a regression line of percentage absence and number per metre square computed for one site,

TABLE 10. ESTIMATE OF POPULATION DENSITY FROM PERCENTAGE ABSENCE AND COMPARISON WITH ESTIMATE FROM DIRECT COUNTS.

THE JUNCUS SITE 1961

Date	Log of percentage absence	No. spittles /m ² from regression	No. spittles /m ² from counts
May 17	1.00	53	56 ± 7.8
22	0.52	78	74 ± 5.6
25	0.52	78	76 ± 8.0
28	1.23	41	42 ± 6.6
June 1	1.24	40	44 ± 5.4
8	1.09	48	50 ± 5.3
12	1.18	43	44 ± 5.2
15	1.35	34 *	42 ± 6.6
18	1.18	43	38 ± 5.3
21	1.35	34	32 ± 4.1
23	1.39	32	36 ± 4.6
27	1.35	34	30 ± 3.7
30	1.54	24	28 ± 4.3
July 3	1.39	32 *	24 ± 3.2
6	1.63	19	16 ± 2.8
9	1.74	13	14 ± 2.9
12	1.67	17	16 ± 2.4
18	1.76	12	12 ± 2.3
21	1.65	18	18 ± 3.5

* Indicates cases where the computed figure lies outside the observed figure with its standard error.

may be utilised with considerable confidence to estimate the population densities on other sites. The method has the virtue of speed and is of value where quick comparisons are necessary.

It is, of course, necessary to select a quadrat size such that a reasonable number of empty quadrats may be expected. If this optimum quadrat size differs from site to site, the original regression can still be used because there is a relationship between quadrat size and frequency (Greig-Smith 1957):

$$\log_e \frac{100 - F_1}{100 - F_2} = a_2 - a_1$$

Where F_1 = frequency at quadrat size a_1
 F_2 = frequency at quadrat size a_2

TABLE 11. ESTIMATE OF POPULATION DENSITY FROM PERCENTAGE ABSENCE AND COMPARISON WITH ESTIMATE FROM DIRECT COUNTS.

THE NARDUS SITE 1961

Date	Log of percentage absence	No. spittles /m ² from regression	No. spittles /m ² from counts
June 1	1.09	48	42 ± 6.7
7	0.69	70	72 ± 8.6
14	1.00	53	54 ± 7.0
20	1.39	32 *	42 ± 7.2
27	1.44	29	28 ± 4.1
July 2	1.69	16 *	24 ± 6.3
9	1.51	25	24 ± 3.8
14	1.74	13	17 ± 5.4

* Indicates cases where the computed figure lies outside the observed figure with its standard error.

2. SAMPLING OF JASSIDAE, DELPHACIDAE AND ADULT CERCOPIIDAE

a) SWEEP NET SAMPLING

The sampling of insects which are capable of flight or rapid movement presents special problems. Sweep netting has been widely used and may be of considerable value for comparing the insect populations of two similar vegetational sites or for sampling the same site at different times. Marshall and Gyrisco (1951) and Wilson and Davies (1953) used the method for sampling adult Philaenus spumarius, although it cannot give an absolute measure of the numbers of insects present as was required for the present study.

Much has been written about the suitability of net sampling for the collection of quantitative samples. Even though the method may be standardized in order to provide comparative information for a succession of samples in the same, or similar areas (e.g. Kontkanen 1950), the effects of weather on the sampling cannot be disregarded (Hughes 1955, De Long 1932). Both these authors point out the marked effect of wind speed and temperature fluctuations within the vegetation, on sampling efficiency.

De Long criticizes sweep net sampling in vegetation of different heights because in the low vegetation the proximity of the ground makes sweeping difficult, whilst tall plants do not easily yield representative samples. In the present study the vegetation sampled was sufficiently short for the following criticism to be valid also:

If a sweep net 36 cms in diameter is brushed through vegetation 6 cms high, it will sample approximately one and a half times the area covered in vegetation 3 cms high.

With these criticisms in mind, it was decided to abandon the sweep net for detailed sampling from which mortality estimates were required, although it was used for purposes of general collection and for comparing different areas on the Limestone Grassland (cases where vacuum sampling would have been too laborious). In these cases, a nylon net 36 cm in diameter and with a 70 cm handle was used. The Homoptera were picked out of the net with an aspirator and after killing in ethyl acetate vapour, were either pinned or preserved in 75 per cent alcohol.

b) SUCTION SAMPLING

Linnavuori (1952) was of the opinion that "The sweep method is the only possible means of taking quantitative leafhopper samples". However, an alternative technique for sampling vegetational sites has since been developed by several workers. A portable electric (or hand driven) suction pump which draws the animals into a nylon collecting bag has been used by Kennard and Spencer (1955), Dietrich et al (1960), and Southwood and Pleasance (1962). Remane (1958) used the method to sample Homoptera - Auchenorrhyncha and his device was driven by a 500cc. petrol motor. The electric pumps described by these authors have the limitation of running on a mains supply and are therefore not suitable for use at Moor House or other areas far from a suitable power supply.

FIG. 4 SECTIONAL DRAWING OF THE VACUUM EXTRACTOR.

FIG. 4

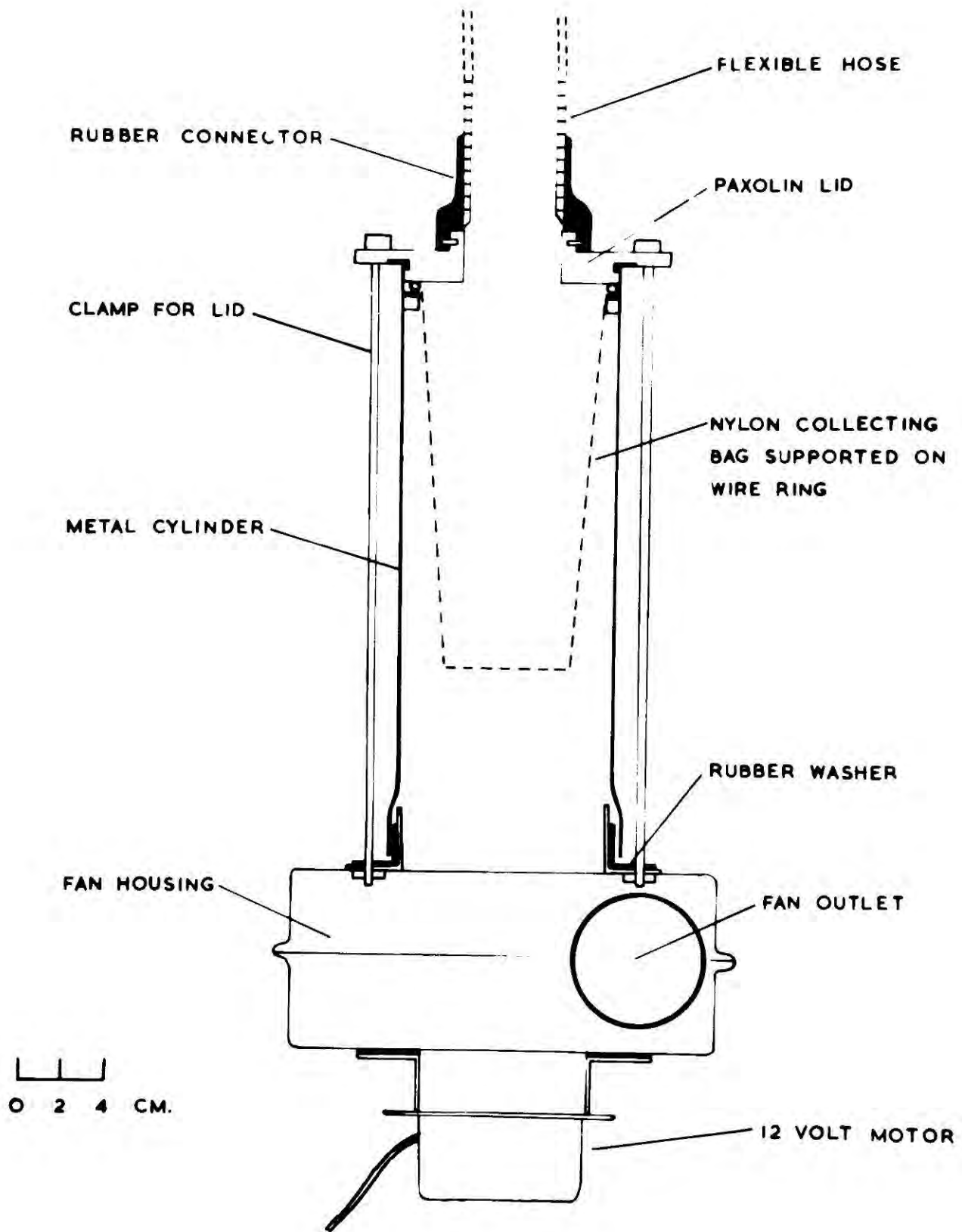

SECTIONAL DRAWING OF VACUUM EXTRACTOR

PLATE 4. THE SUCTION SAMPLER.

On the left is the 12 volt battery mounted on a pack frame. The hose from the vacuum is resting across the cylinder ($1/10 \text{ m}^2$) used to delimit the sample area.



A modified form of the machine described by Johnson, Southwood and Entwistle (1957) was constructed for the present study, which could operate from a 12 volt battery and so was completely mobile. The apparatus (Fig. 4), is described in Appendix 1.

1. Operation of the Apparatus. (Plate 4).

Samples were taken by systematically drawing the nozzle through vegetation delimited by a cylinder covering a known area (either $1/10 \text{ m}^2$ or $1/20 \text{ m}^2$), placed quickly down in a random fashion and pushed well into the vegetation and soil. The cylinder was high enough to prevent Homoptera from escaping.

After sampling, the nylon collecting bag contained the animals plus a considerable amount of detritus (dead grass etc.). The whole of this was transferred to screw-top glass jars of the same diameter as the top of the collecting bag. Twenty such samples were taken on each sampling date. The samples were examined in the laboratory within an hour or two of collection. The whole of the contents of each jar were transferred to a high-sided white tray and as the debris was sorted with a seeker, the Homoptera present were picked out with an aspirator. Being active, they were quite easy to see, and repeated sorting of several samples showed that the number overlooked was negligible.

Nymphal and adult Cicadellidae and Delphacidae and adult Cercopidae were sampled by this technique. They were either pinned or preserved in 75 per cent alcohol.

TABLE 12. EFFICIENCY OF SUCTION SAMPLER

A on Juncus squarrosus

Sampling regime	No. of marked Homoptera	No. recaptured
2:1:1	8	8 (4:1:3)
2:1:1	7	6
2:1:1	5	4
4:1:1:1	8	7 (4:1:1:1)
1:1:1:1	7	6 (2:3:1:0)
1:1:1	7	4
1:1:1	4	2

B on Limestone Grassland

	Sampling regime	No. of marked Homoptera	No. recaptured
Hummocks	2:1	10	9
	2:1	10	7
Hollows	2:1	10	9
	2:1	10	9

e.g. 2:1:1 = two minutes extraction followed by one minute to empty collecting bag. Then two extractions followed by one minute each, separated by one minute.

ii. Efficiency of the Apparatus.

Homoptera were marked with a quick drying cellulose paint, placed in a cylinder on the vegetation and allowed to return to their normal resting or feeding positions on the plants. They were then sampled according to different regimes as follows: (Tables 12 - 13).

On the basis of these tests, the 2:1:1 regime was adopted for the Juncus site, and a 2:1 regime for the Limestone site. The average extraction efficiency for the two sites was almost 90 per cent.

TABLE 13. SUMMARY OF RECOVERIES BY SUCTION SAMPLER

	No. of marked Homoptera	No. recaptured
<u>J. squarrosus</u> tests 1, 2 & 3	20	18
Limestone Grassland	40	34
Totals	60	52
Percentage recaptured		87

PLATE 5. THE THERMISTOR APPARATUS.

The cable runs from the bridge unit on the left to a mounted F type thermistor. The height of the probe in the vegetation can be adjusted by sliding it up and down the vertical brass rod.



V. THE MICROCLIMATES IN THE VEGETATION OF THE SAMPLE SITES

1. INTRODUCTION

Waterhouse (1955), Broadbent (1950) and others have demonstrated the existence of marked gradients of temperature and humidity amongst vegetation. Both these authors were working on relatively tall vegetation in lowland conditions, and so an attempt has been made to study the occurrence of such gradients on high altitude sites and to compare the different vegetation types upon which Auchenorrhyncha are found at Moor House. Because of the high incidence of strong winds (at least 34 days with gale in 1961, and 42 in 1962) which have a marked effect even on the air layers near to the ground, (e.g. a wind speed of 4 m.p.h. was recorded at 3 cm. on the limestone grassland area on 28 August 1961) large gradients of temperature of the type described by Waterhouse are not often encountered. Marked differences between different vegetation types can, however, be shown. The apparatus used is described in Appendix 1 and is shown in Plate 5.

2. COMPARISON OF JUNCUS AND LIMESTONE GRASSLAND SITES

Because readings could not be taken continuously, it is only possible to illustrate the differences between these two sites by quoting examples of data collected on the two areas.

Table 14 shows the humidity conditions at 11.30 hours on 24 August 1961 amongst Juncus squarrosus and Festuca/Agrostis only 2 metres apart. (See Plate 7). Readings were taken as simultaneously as possible.

TABLE 14. THE HUMIDITY AMONGST JUNCUS AND FESTUCA - AGROSTIS

Habitat	Height above ground surface (cm)	Humidity (Saturation deficit in mm. of mercury).
Juncus	10	4.7
	3	3.4
Festuca/Agrostis	10	8.9
	2	7.6

The humidity amongst the leaves and stalks of Juncus is markedly higher than amongst the adjacent Festuca/Agrostis. Although in this case the Juncus and Festuca/Agrostis areas were distinct, it is also possible to demonstrate clear humidity differences in Juncus squarrosus rosettes and Festuca axils only a few centimetres apart. Each pair of Juncus and Festuca readings in Table 15 were taken within 10 - 15 cm. of each other on 6 June, 1962. At the time the readings were taken (14.00 to 15.00 hours), the screen saturation deficit was 11.8 mm. Hg. and there had been an average of 14.2 hours of sunshine over the previous three days, with maximum screen temperatures of 16.7 - 17.8°C. There had been no rain for the previous six days, and only 0.22 inches over the previous eleven days.

The humidity at the base of the Juncus rosettes was markedly higher than at the axils of the Festuca. The effect of this on the hatching of cercopid eggs will be discussed later.

GRADIENTS IN VEGETATION

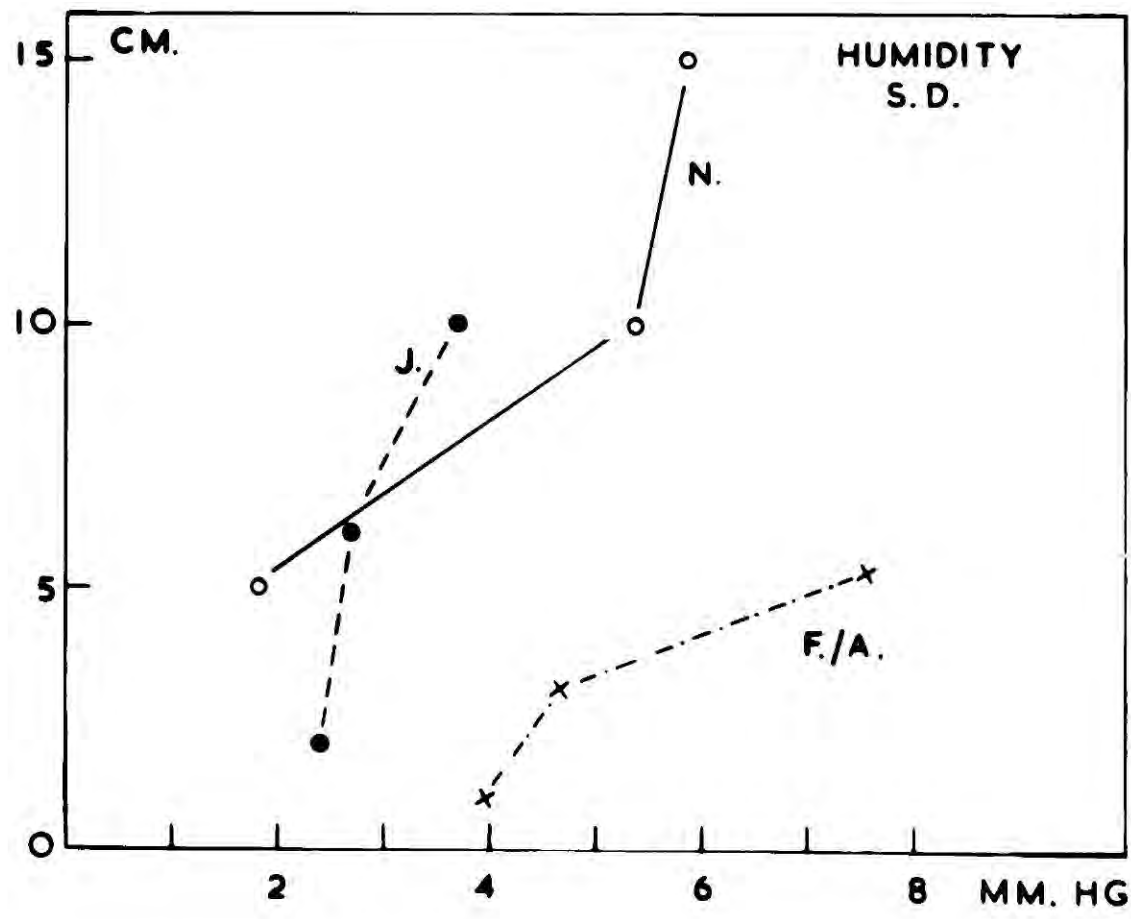
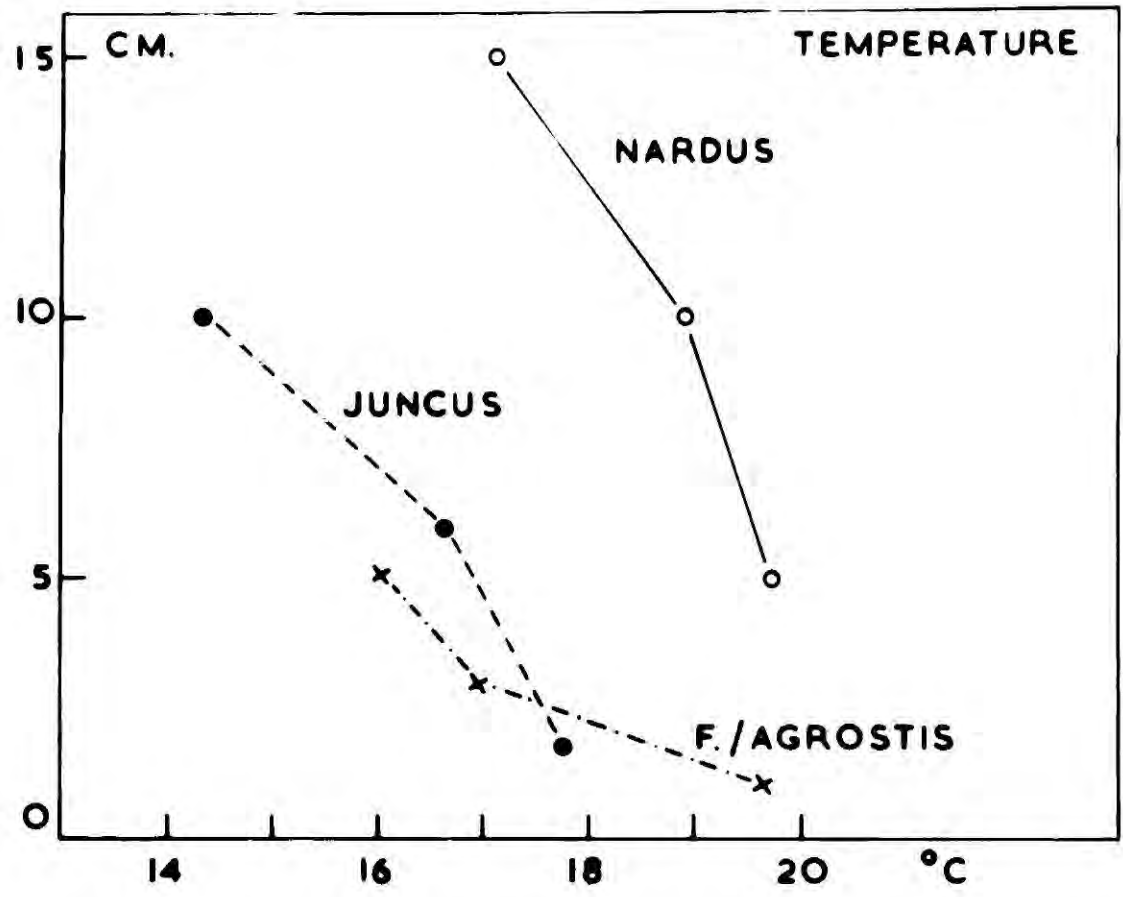

TABLE 15. SATURATION DEFICIT IN JUNCUS AND FESTUCA, 6 JUNE 1962.

Locations	Saturation Deficit (mm. Hg.), mean of three readings	
	<u>Juncus</u>	<u>Festuca</u>
A	10.1	18.9
B	12.8	13.4
C	10.6	16.2
D	8.4	16.6
E	5.5	12.8
Mean \pm S.E.	9.6 \pm 0.7	14.7 \pm 0.7

Fig. 6 represents similar gradients of humidity on adjacent Juncus, Nardus and limestone grassland sites measured on 11 July 1962 at 15.30 hours. The limestone grassland (Festuca/Agrostis) is less humid than the Nardus which is in turn less humid than the Juncus. The corresponding temperature gradients for these three sites are shown in Fig. 5 and although the gradients cover approximately the same range in each vegetation type (about 4⁰C.), the temperature is lower in the Juncus than in the Nardus or Festuca/Agrostis.

These are simply examples of occasions when distinctly measurable gradients of temperature and humidity were recorded. By repeating such recordings under different macroclimatic conditions it has been found that measurable temperature gradients are only established under conditions of low wind speed (less than 10 m.p.h. at a 50 feet anemograph), and with the sun unobscured by cloud. The latter is most important because repeated observations made on days during the Homoptera season

PLATE 6. HUMMOCKS AND HOLLOWES ON THE LIMESTONE
GRASSLAND SITE.

The upstanding blocks of limestone, separated by grikes, are clearly visible. The differences in the vegetation can also be seen; that on the hummocks being taller.

PLATE 7. JUNCTION OF JUNCUS SQUARROSUS AND
FESTUCA/AGROSTIS.

The sharp distinction between Juncus (on the left), and Festuca is shown. This site was used for comparison of gradients in the two vegetation types, and also for the sampling of N. lineatus and N. exclamatoris nymphs, described in Section VII.



when the sun was periodically obscured by cloud showed that the temperature gradient was quickly lost when the sun was obscured, but re-established in conditions of insolation. An analysis of the meteorological data during the months when *Auchenorrhyncha* are present at Moor House (May to September), has shown that the required wind speed and insolation conditions only occurred on 30 days (1961) and 25 days (1962), out of a total of 150 days. Marked temperature gradients are only likely to be established on these occasions. Humidity gradients, on the other hand, are accentuated by high wind speeds and are almost always present in vegetation at Moor House.

3. COMPARISON OF HUMMOCKS AND HOLLOWES ON LIMESTONE GRASSLAND. (PLATE 6)

The physiographic and floristic differences between the hummocks and hollows on the limestone grassland have already been discussed. These give rise to the development of different temperature and humidity gradients. On days on which measureable gradients were established (e.g. 15 August and 2 September 1961), the hummock vegetation was found to be less humid than that in the hollows (e.g. Mean saturation deficit on hummocks 6 mm. Hg., in hollows 3.8 mm. Hg. at 14.00 hours on 15 August 1961). The readings are reproduced in Table 16. Temperature gradients were also different in the two habitats (e.g. Fig. 7). The vertical gradient is much steeper in the hollows than in the taller vegetation of the hummocks. This probably results from a difference in the positions of the "outer active surfaces" (Geiger 1959) of the two vegetation types. The

**FIG. 7 TEMPERATURE GRADIENTS IN HUMMOCK AND HOLLOW
VEGETATION ON THE LIMESTONE GRASSLAND SITE.**

The readings were taken at 12.00 hours on
2 September, 1961 when the screen readings
were as follows;

Wet bulb = 11.6°C . Dry bulb = 17.7°C

S.D. = 11.8 mm. Hg.

FIG. 7

TEMPERATURE GRADIENTS IN *F. AGROSTIS*

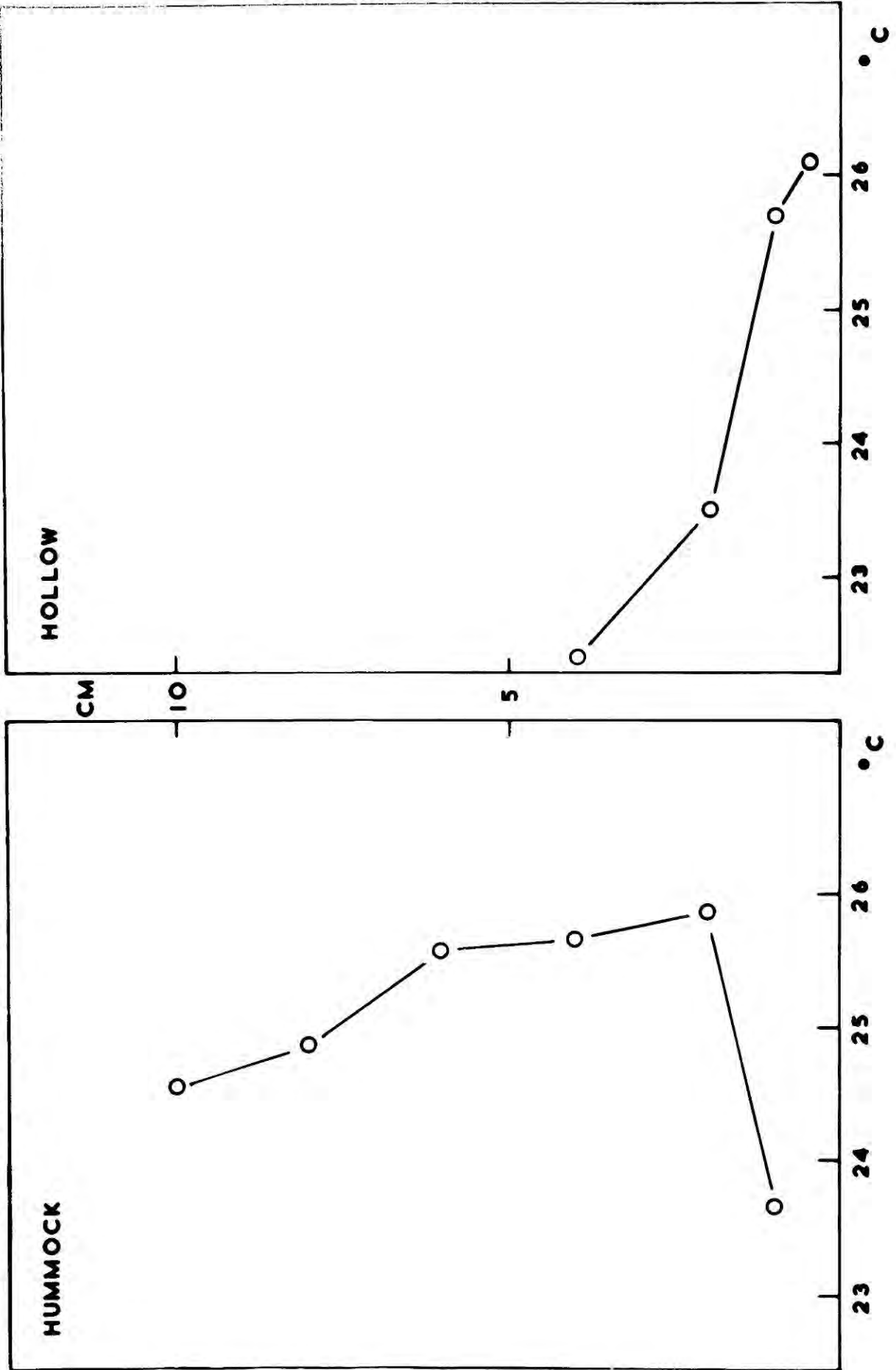

vegetation in the hollows is too short for any appreciable fall off in insolation, so that the gradient depends largely on conductive heating from the ground surface and thus temperatures are highest near to the surface and fall off away from it. On the hummocks, however, the vegetation is taller and denser, and incoming radiation will be mostly absorbed before reaching the ground surface. The highest temperatures are therefore found just above the ground surface, where the vegetation increases in density but the strength of incident radiation has not fallen off appreciably.

TABLE 16. SATURATION DEFICITS IN HUMMOCK AND HOLLOW VEGETATION
(14.00 hours on 15 August 1961)

	Dry bulb temp. °C	Wet bulb temp. °C	Saturation deficit (mm. Hg.)
Hummocks	18.0	14.8	6.4
	17.0	13.8	6.2
	18.2	14.9	6.7
Mean			6.4
Hollows	17.2	15.7	2.9
	18.7	17.0	3.9
	19.5	17.4	4.5
Mean			3.8

4. THE MICROCLIMATE OF CERCOPID SPITTLE.

The presence of foam or spittle on many plants in spring and early summer has attracted the attention of naturalists for centuries. Theories ranging from its production by the cuckoo (attributed to St. Isidore of Seville), to the natural exudation of the plants themselves (Bock, 16th Century) or when punctured by Homoptera (Fabre 1900), have been accepted until recent times. It was, however, pointed out by Blankaart (1690) that the fluid came from the anus of the insect, and the mechanism of its production has now been described by such authors as Sulc (1911), Gahan (1918) and Cecil (1930).

The role of cercopid spittle as a protector from desiccation has often been discussed in the literature (e.g. Weaver and King 1954) and is no doubt important. The relatively immobile nature of the nymphs when so enclosed means that the build up of high temperatures in the vegetation is not readily counteracted by vertical migration into a cooler part of the gradient such as can be made by adult Cercopidae or Cicadellidae and Delphacidae (see later).

Under conditions producing a marked gradient of temperature, recordings were made of the temperatures inside and outside spittle masses. In all cases measured, the temperature within the spittle was less than that of the air surrounding it. To illustrate this point, some readings taken in the laboratory field, Durham on 8 June 1962 are recorded in Table 17.

TABLE 17. THE TEMPERATURES INSIDE AND OUTSIDE SPITTLE IN THE LABORATORY FIELD, DURHAM.

Temperature outside spittle °C	Temperature inside spittle °C	Difference °C
27.3	26.8	- 0.5
28.9	27.0	- 1.9
23.1	22.5	- 0.6
22.0	20.7	- 1.3
24.5	24.1	- 0.4
24.4	23.6	- 0.8
23.0	21.3	- 1.7
22.6	21.7	- 0.9

This may be expected purely on the grounds that evaporation from the surface of the spittle would cause cooling.

Spittle size:-

The relationship of spittle size to its height from the ground was examined on Juncus squarrosus at Moor House and the laboratory field, Durham. Since spittles are roughly of a constant shape, the maximum width was used as an index of its volume. This was correlated with the height of the spittle above the ground surface. In the laboratory field 30 spittles showed a negative correlation of size and height ($r = - 0.78$), and this was also the case on the Juncus (for 40 spittles, $r = - 0.88$). The data is reproduced in Figs. 8 and 9.

**FIGS. 8 and 9 THE RELATIONSHIP BETWEEN SPITTLE WIDTH
AND ITS HEIGHT ON THE HOST PLANT.**

FIG. 8 In the laboratory field, Durham

$$(y = 11.99 - 0.257x)$$

FIG. 9 On Juncus squarrosus at Moor House

$$(y = 15.3 - 1.12x)$$

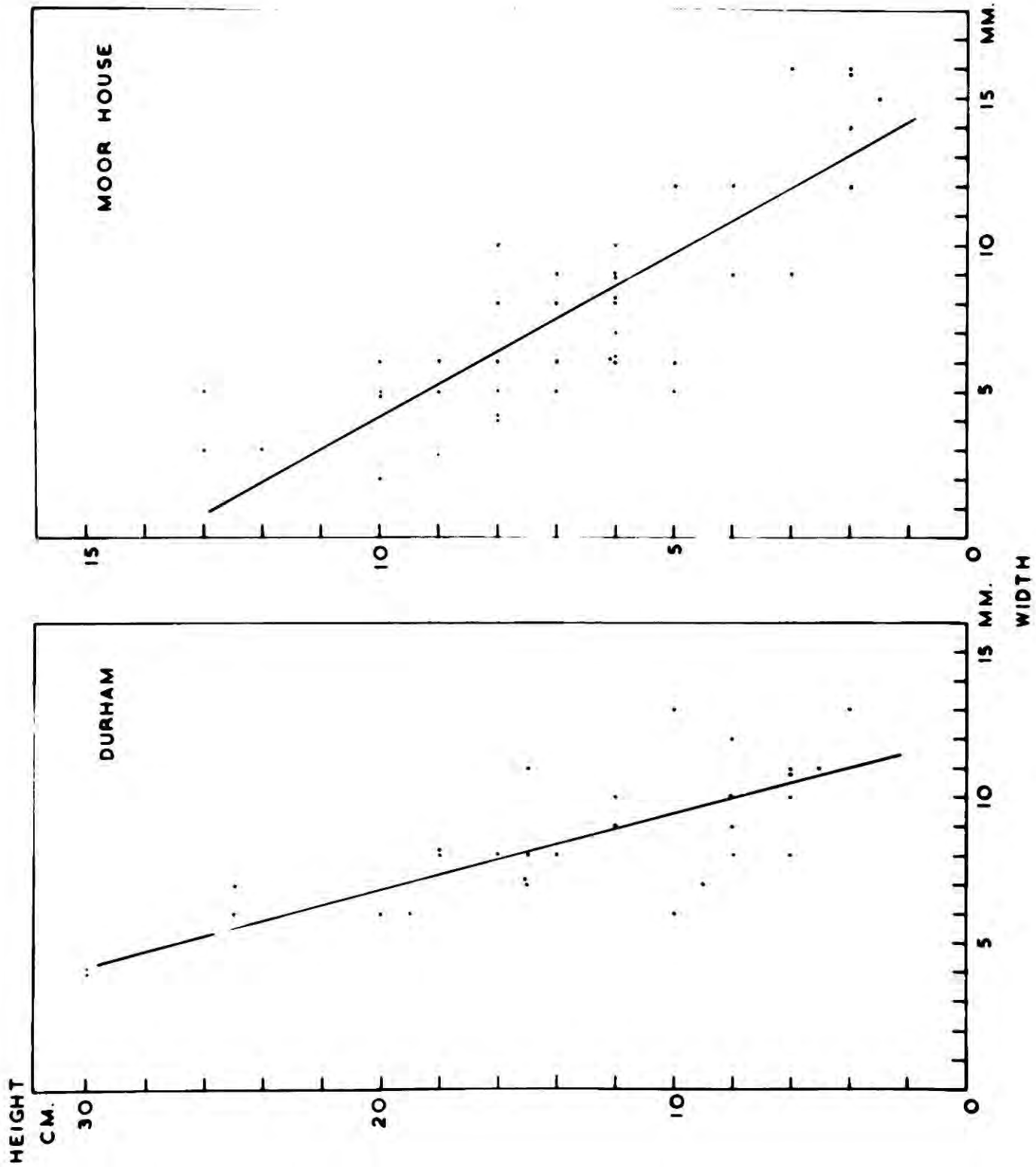

The production of spittle is a bi-product of feeding and so it may be expected that the nymphs will be unable to control the size of their spittle to any great extent. This was tested experimentally in the laboratory. Replicates of two experiments were set up :

- i. A portion of turf was cut and placed on a gauze in a desiccator containing water up to the level of the gauze. This was sealed until a high humidity (saturation) was established, and then 5 final instar nymphs were introduced at various heights in the vegetation in each of three such containers. To ensure that the nymphs should feed at the positions at which they were placed on the host plants, the desiccator was covered to exclude light. (It has been found that in daylight, nymphs placed on a plant will move down towards the ground surface before commencing feeding. In darkness, however, they do not move before feeding. Thus nymphs in the field surrounded by a metal cylinder with a glass lid moved down the host before feeding, but did not move if the lid was opaque. This movement was therefore a reaction to light and not to disturbance of the vegetation by wind).
- ii. A similar experiment was set up in which the desiccators contained a little water in the base, but calcium chloride was placed above the vegetation. This had the effect of producing a gradient of humidity ranging from 100 per cent at the water surface to 35 per cent above the vegetation. Five final instar nymphs were introduced into each of three such desiccators.

After 10 hours, the resultant spittle sizes and their heights in the vegetation were recorded (Table 18). Not all the nymphs successfully established and produced spittle.

TABLE 18. SPITTLE SIZES AND HEIGHTS IN EXPERIMENTAL CONDITIONS.

No. Gradient. Humidity 100% throughout		Gradient Humidity 35 - 100%	
Height on host plant cm.	Width mm.	Height on host plant cm.	Width mm.
2	8	2	9
4	9	5	8
6	7	6	7
6	7	7	6
7	9	7	5
7	10	7	4
8	7	8	5
8	8	8	6
10	8	9	4
11	9	9	3
		9	3
		10	3

The data in Table 18 is graphed in Fig. 10, and it can be seen that in the vegetation which had 100 per cent relative humidity throughout,

**FIG. 10 THE RELATIONSHIP BETWEEN SPITTLE WIDTH AND
ITS HEIGHT ON THE HOST PLANT, IN EXPERIMENTAL
LABORATORY CULTURES**

a) In a saturated atmosphere

$$(y = 7.96 + 0.035x)$$

b) In a humidity gradient of 35 - 100

per cent R.H. ($y = 11.75 - 0.89x$).

FIG. 10

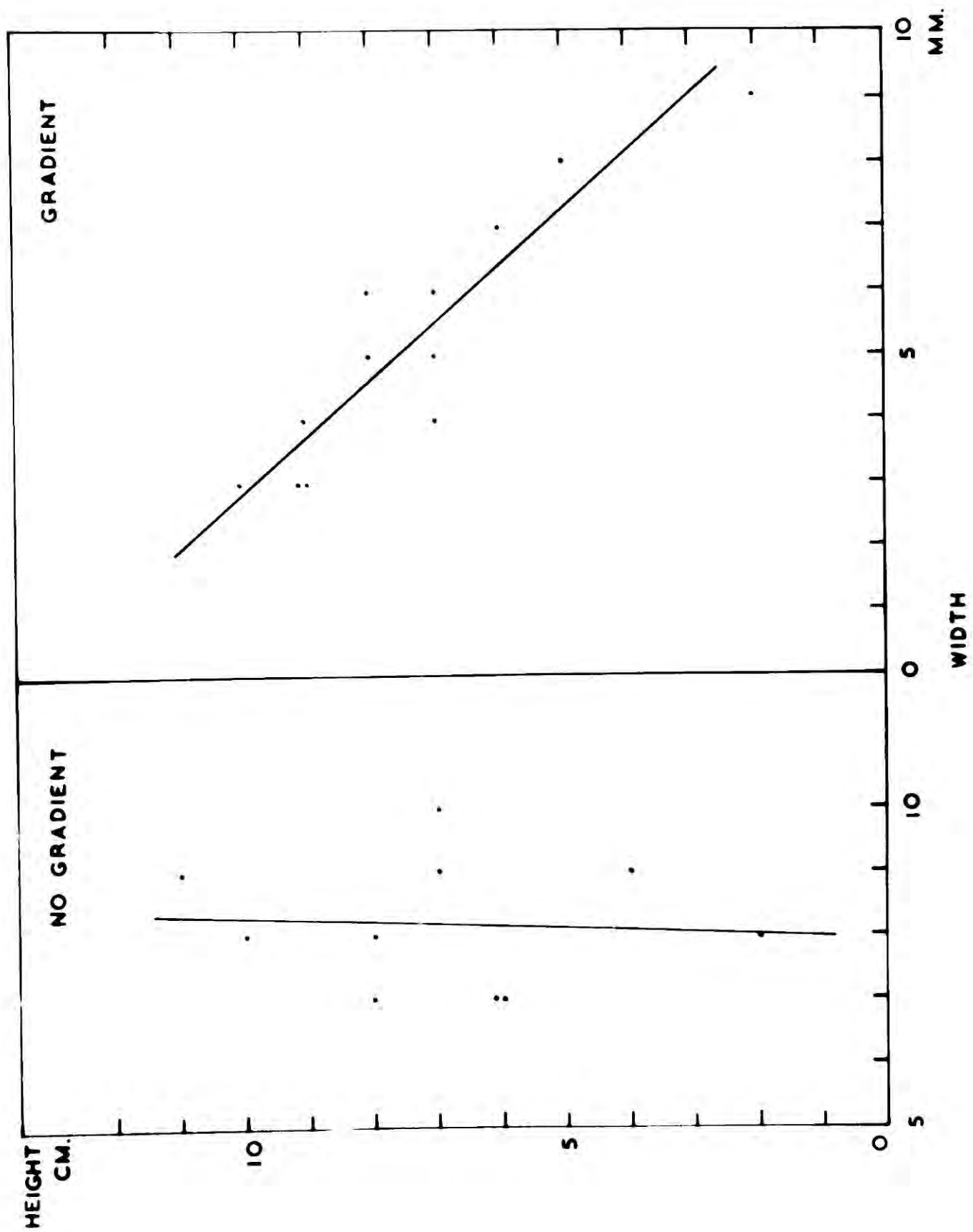

the size of the spittle is not correlated with its height on the plant ($r = + 0.08$ with 8 degrees of freedom). That is to say, whether or not the nymph is feeding near to the base of the plant or high on the leaves or stem, the spittle production is the same, presumably because the food intake is the same. In a steep humidity gradient, however, spittles near to the base of the plants (in a humid atmosphere) are larger than those high on the plants (which are evaporating much more rapidly). There is thus a high negative correlation between spittle height and spittle size ($r = - 0.95$ with 10 degrees of freedom). The volumes of the spittles (computed from the width assuming that the spittle is spherical) vary by as much as a factor of 25 in such a sharp gradient.

Rates of evaporation were compared in a second experiment in which spittles of equal volumes from which the nymphs had been removed, were placed (on their host plant) in a desiccated atmosphere (R.H. 20%) or in a saturated atmosphere. Those in the desiccated atmosphere were all completely evaporated within 4 hours whilst those in the saturated atmosphere persisted for 30 hours (when the experiment was concluded).

The following hypothesis for the function of cercopid spittle as an insulator from temperature fluctuations is suggested :

The higher humidity near to the ground surface allows less evaporation of the spittle and since the rate of production is independent of the height of the spittle in the vegetation, more will accumulate than would higher in the vegetation. But Fig. 5 shows

that the temperature is also higher nearer to the ground (a typical incoming radiation-type gradient). The greater quantity of spittle near to the ground acts as a more efficient insulator so that the temperature depressing effect of the spittle is greatest near to the ground surface where the temperatures are highest. It is suggested that the relatively immobile nymph is protected in this way from high temperatures which may develop near to the ground during daytime in-coming radiation. Only if the insulating properties of the spittle prove inadequate will the nymph have to leave its spittle and re-establish itself at a greater height (and thus a lower temperature) in the vegetation. The less mobile cercopid nymph has therefore less need to move up and down its host plant than have the more active Delphacidae and Cicadellidae.

This hypothesis was tested by field measurements. Figs 11 and 12 summarise data collected on 30 August 1961 to show the type of temperature and humidity gradients present in a stand of Nardus. Both are of the types already described. At the same time, instar five spittles at three heights in the vegetation were studied and these are shown digrammatically in Fig. 12 with the temperature differences inside and outside the spittles. The spittles closest to the ground surface are the largest, and have the greatest insulating effect. Thus although cooling from evaporation will be lower near to the ground surface, this is more than counteracted by the insulating effect of the larger spittles.

FIG. 11 TEMPERATURE GRADIENT IN NARDUS

At 14.00 hours on 30 August, 1961.

FIG. 12 HUMIDITY GRADIENT IN NARDUS

At 14.00 hours on 30 August, 1961.

Spittle sizes at different heights are shown diagrammatically and the temperature difference between the centre of the spittle and the surrounding air is given alongside each one.

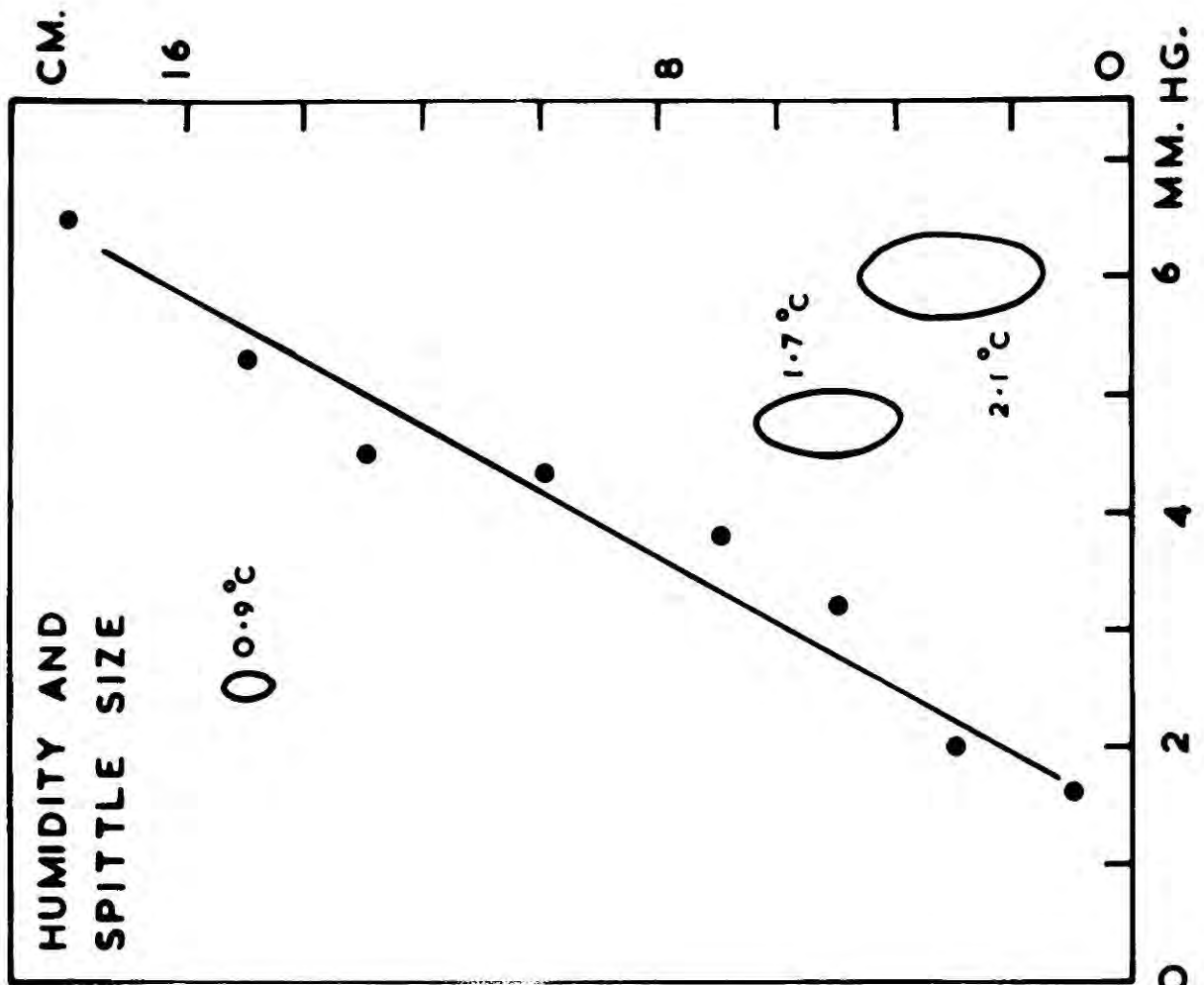
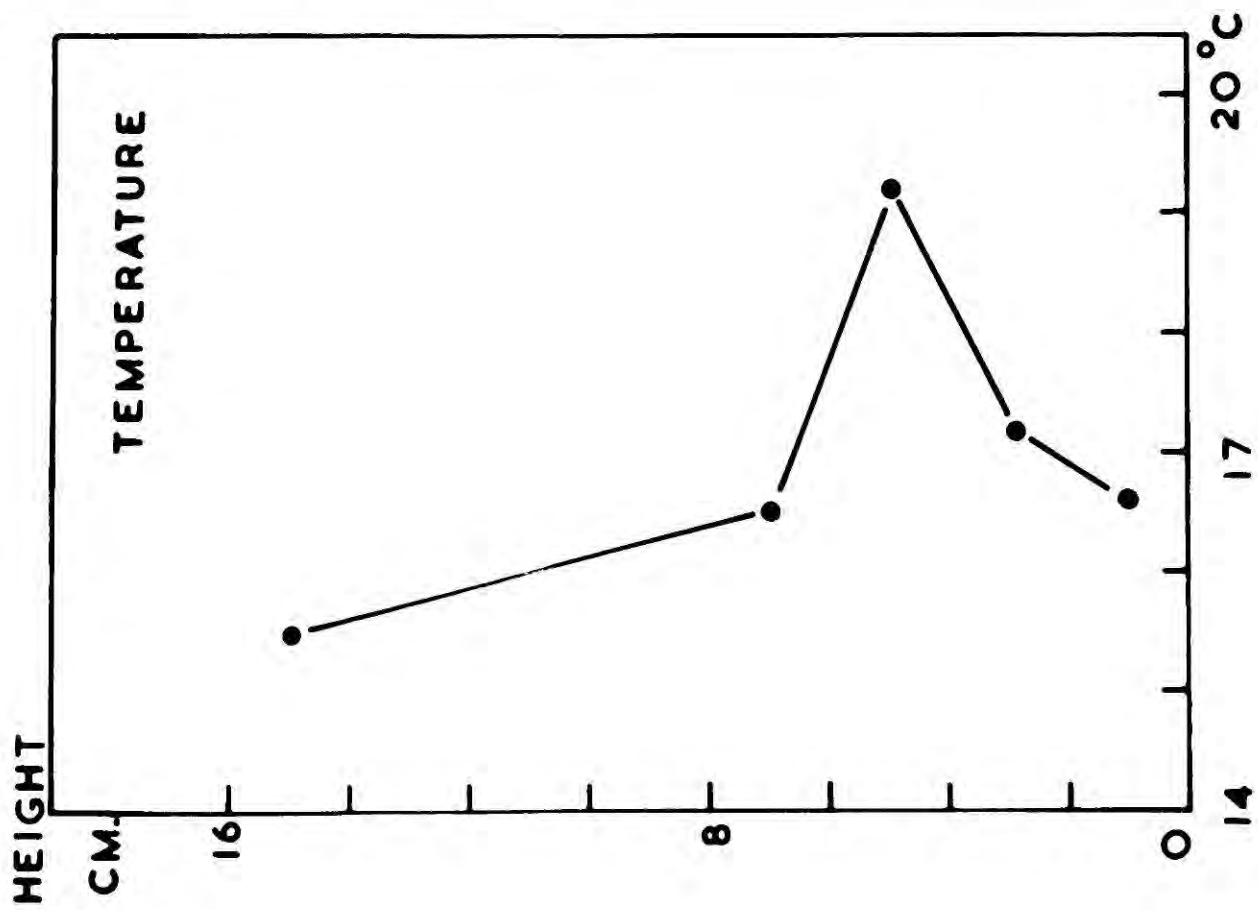

5. THE EFFECT OF A HIGH TEMPERATURE GRADIENT ON AUCHENORRHYNCHA OTHER THAN NYMPHAL CERCOPIDAE.

The development of marked gradients of temperature and humidity has been discussed. It has been shown that the effects of these on nymphal Cercopidae is minimised by the presence of their protective spittle. In August 1962, sampling was carried out on the limestone grassland hummocks to determine what effect such gradients had on the vertical distribution of other Auchenorrhyncha without protective spittle. Vacuum sampling was used but each sample was divided into two. The upper half of the vegetation was sampled first, and then the whole of the vegetation. Thus the first sample removed Auchenorrhyncha from high on the grass, and the second sample removed those remaining close to the ground surface.

On 3 August, cloud (total sunshine 0.3 hours) and a strong wind (mean 15.8 m.p.h.) made conditions unfavourable for the development of a temperature gradient on the limestone grassland. Under these conditions, the upper half of the vegetation contained 14 ± 3.0 Auchenorrhyncha per square metre, and the lower half contained 18 ± 4.5 per square metre. On 8 August, conditions were favourable for the establishment of a marked temperature gradient of the type shown in Fig. 7. Sampling the upper part of the vegetation only, yielded 20 ± 8 Auchenorrhyncha per square metre, whilst the vegetation close to the ground surface yielded none. Thus when temperature gradients are absent, the Auchenorrhyncha are distributed throughout the vegetation, but if the temperature close to the ground surface rises as a gradient is established, they move into cooler (i.e. higher) vegetation.

VI. THE BIOLOGY OF NEOPHILAENUS LINEATUS

A. THE NYMPHAL INSTARS

1. INTRODUCTION

Neophilaenus lineatus (Linnaeus 1758) is the commonest species of cercopid at Moor House and occurs from May to September (nymphs from May to July) on areas of damp grassland or rushes. (Plate 9). Large areas of the Reserve on the fell slopes and in the stream valleys are characterized by these vegetation types and so representative sampling areas on Juncus squarrosus, Nardus stricta and an altitudinal transect were selected and have been described in Section II.

In common with other British Cercopidae, N. lineatus overwinters in the egg stage and has one generation per year. The general features of its life history have been described by Osborn (1916) and Garman (1921) but the present study has revealed some inadequacies in their work. In particular, it will be shown that the species has five and not four nymphal instars as described by Garman. In spite of the economic importance of certain Cercopidae in North America, population studies have been largely confined to comparisons of areas treated and untreated with insecticides, rather than estimates of absolute density at different stages in the life history. This has been done in the present study and the mortality on different vegetation types and at different stages in the life history compared. Particular attention has been paid to the nymphs' relations with their host plants and to their dispersion characteristics on the

sampling sites. The effect of altitude on the time of hatching and the rate of development is discussed.

2. DETERMINATION OF INSTARS

During the 1961 field season, N. lineatus nymphs collected were rapidly sorted into instars according to the descriptions given by Garman (1921). This appears to be the only description available in the literature and recognises four instars, which are characterised by the colour of the head and prothorax. The size range which he quotes for his instar two is suspiciously large and during the sorting of Moor House material it was noticed that the nymphs fitting the description of this instar covered a greater size range than would be expected. Measurements were later made therefore of several nymphal characters to confirm the number of instars. The measurements were of head width (across the eyes), first tibia length and wing bud length. Nymphs were randomly selected until a total of 50 individuals in each size group had been measured. Frequency distribution histograms of each of the characters measured showed five distinct peaks (Fig. 13). The second and third peaks of these histograms are composed of nymphs answering to the description of Garman's instar two. It is likely that Garman failed to distinguish between these two instars because his measurements were of the body length of specimens preserved in alcohol - a very variable character in soft bodied nymphs.

FIG. 13 **FREQUENCY DISTRIBUTION HISTOGRAMS OF THE
NYMPHAL INSTARS OF N. LINEATUS.**

a) Width of head capsule.

b) Length of first tibia.

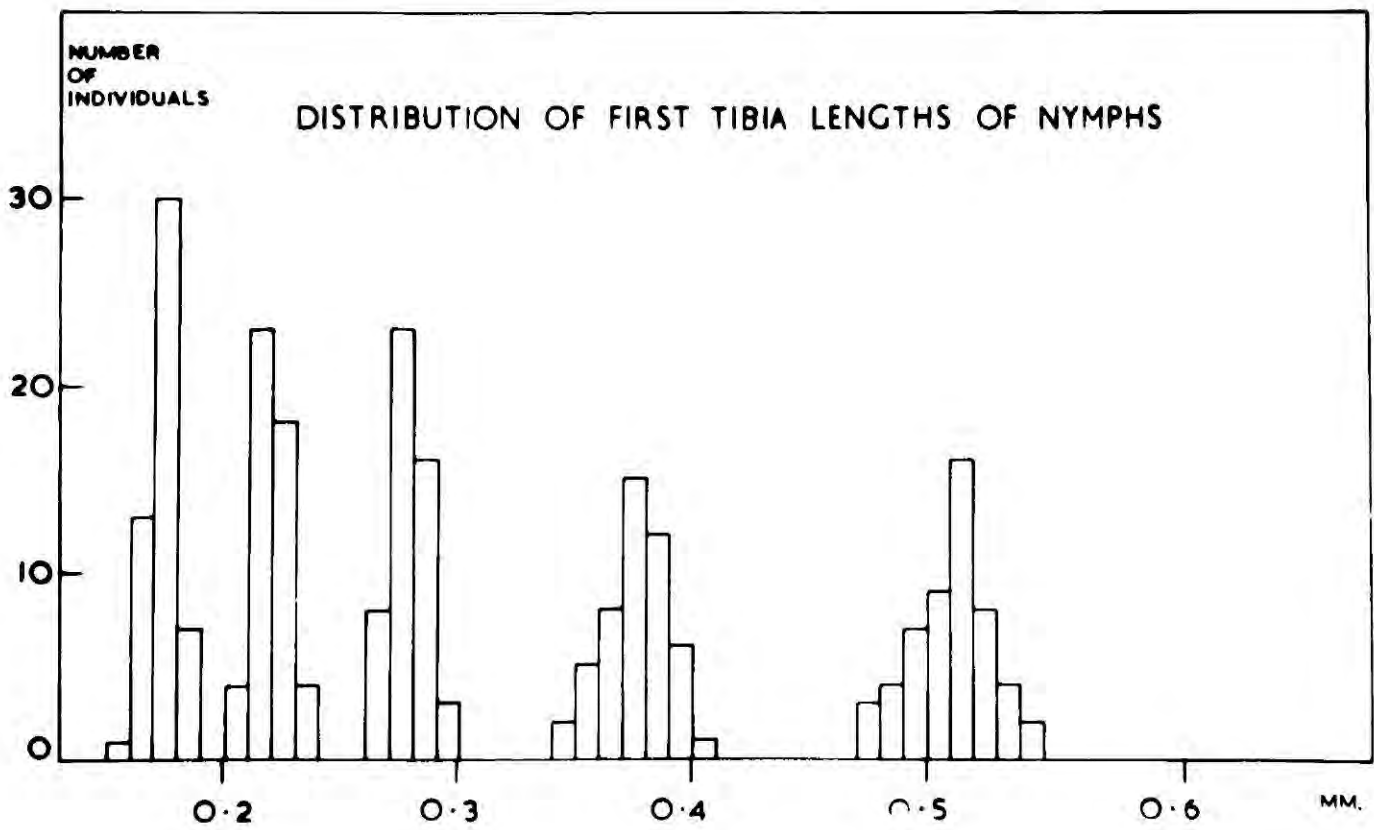
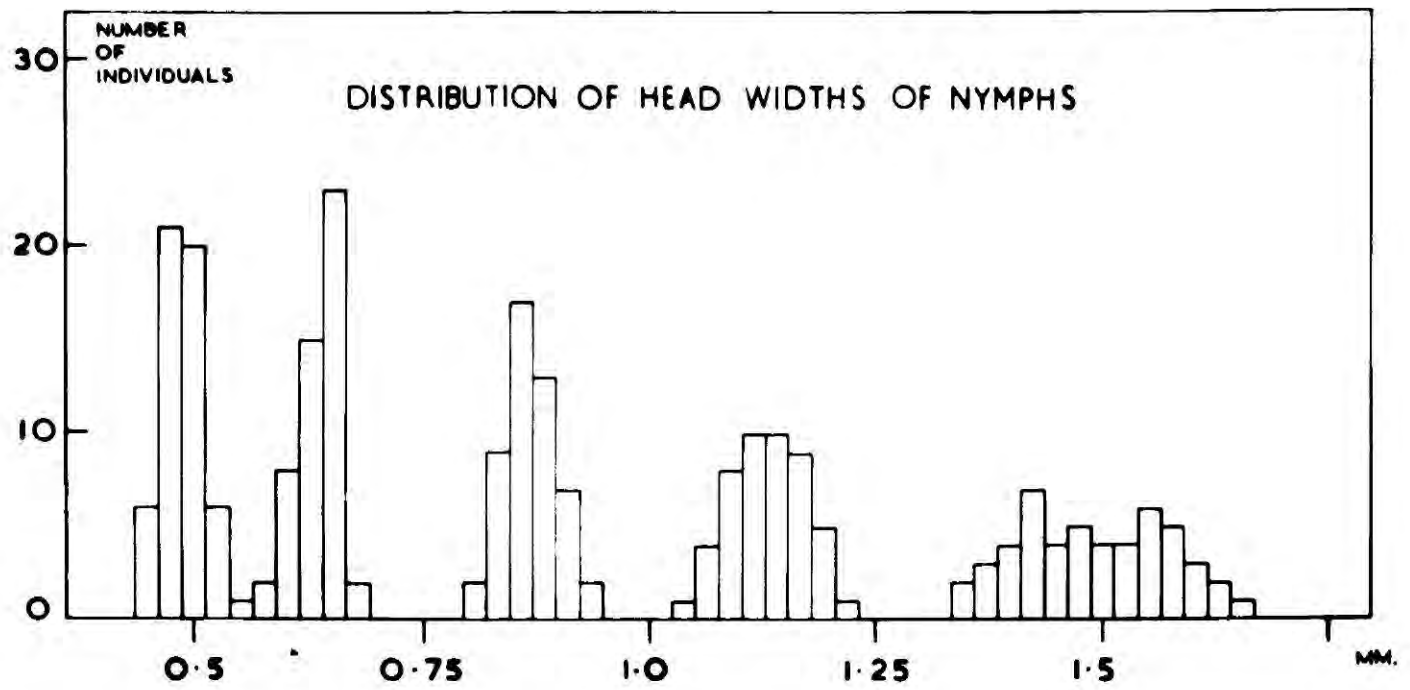

It was first pointed by Dyar (1890) that the relative increase in width of the head of lepidopterous larvae remains practically constant from one instar to the next. Since then, the same has been found to be true for linear measurements of many cuticular structures (e.g. Duarte 1939).

TABLE 19. HEAD WIDTHS OF *N. LINEATUS* FROM MOOR HOUSE

Instar	1	2	3	4	5
Number measured	54	50	50	48	50
Observed mean head width (μ) and S.D.	470 \pm 23	620 \pm 24	850 \pm 29	1120 \pm 41	1480 \pm 81
Rate of increase	1.31	1.37	1.30	1.32	(Mean 1.33)

TABLE 20. HEAD WIDTHS OF *N. LINEATUS* FROM LABORATORY FIELD DURHAM

Instar	1	2	3	4	5
Number measured	31	30	30	30	30
Observed mean head width (μ) and S.D.	470 \pm 23	640 \pm 29	880 \pm 32	1200 \pm 67	1560 \pm 50
Rate of increase	1.34	1.38	1.36	1.30	(Mean 1.35)

TABLE 21. DIFFERENCE AND STANDARD ERROR BETWEEN MEAN HEAD WIDTHS OF *N. LINEATUS* AT MOOR HOUSE AND DURHAM

Instar	1	2	3	4	5
Difference in means(μ)	0	20	30	80	80
	\pm	\pm	\pm	\pm	\pm
Standard error of difference	0	6.3	7.1	13.6	14.6

Insects which obey Dyar's law therefore show a geometrical size increase at each moult. The logarithms of the means of a series of measurements of a character such as head width when plotted for each instar should therefore show a straight line relationship. Actually this progression is rarely exactly regular unless account is taken of the different durations of the instars. (Richards 1949).

The ratios of the mean head widths from one instar to the next are shown in Table 19 and these are sufficiently regular in *N. lineatus* for an almost straight line relationship when plotted logarithmically. (Fig. 14). The fact that this line is almost straight indicates that it is unlikely that another instar exists between the five postulated for this species. The existence of five instars in *N. lineatus* has also been shown by examination of the exuviae of each instar which can often be found in the spittle.

FIG. 14 **LOGARITHMS OF THE MEAN AND STANDARD
DEVIATION OF THE HEAD CAPSULE WIDTHS
OF THE NYMPHS OF N. LINEATUS.**

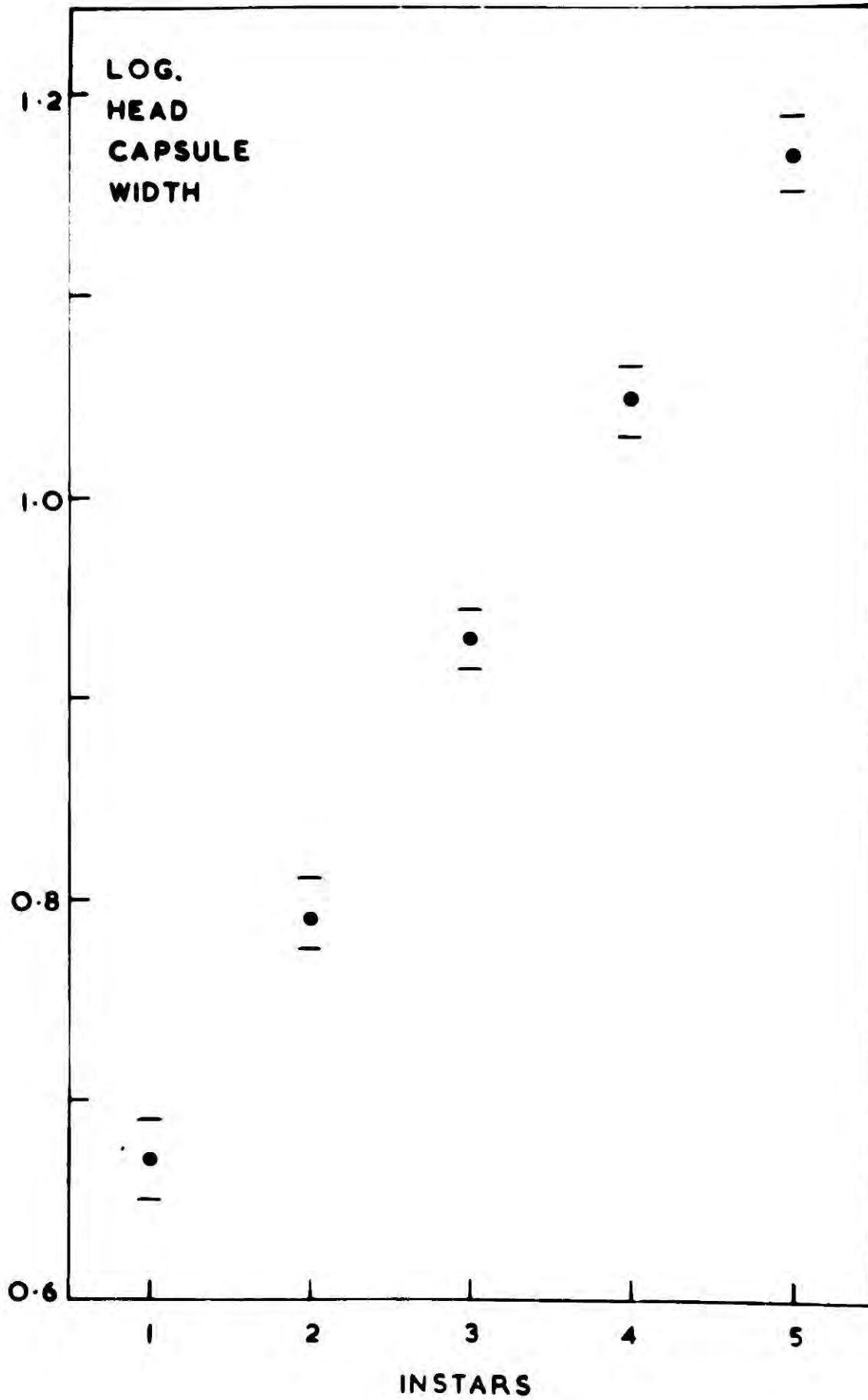
LOGARITHMS OF HEAD WIDTHS OF *N. LINEATUS*
NYMPHS

In the only other cercopid for which data are available in the literature, Philaenus spumarius, measurements have shown the existence of five instars, not four as originally suspected (Weaver and King 1954).

Measurements have also been made of 30 individuals in each instar from collections of N. lineatus made in the grounds of the Durham Colleges' laboratories in 1962. (Table 20). The rates of increase were slightly higher than in the 1961 Moor House nymphs and the resulting differences in head widths are significant from instar 2 onwards (Table 21).

3. DESCRIPTIONS OF THE INSTARS

INSTAR 1.

Head, pro-, meso- and metathorax and limbs dark.

Abdomen yellow with distinct red spots on the ventro-lateral aspects of segments 4-6.

Wing buds one and two with little overlap and approximately the same size.

Antennae club-shaped.

Mean head capsule width 0.47 ± 0.023 mm.

INSTAR 2.

Head, limbs and prothorax lighter. Meso- and metathorax darker.

Abdomen still with distinct red spots.

First wing bud approximately 1.5 times the length of the visible part of wing bud two (some overlap).

Antennae club-shaped.

Mean head capsule width 0.62 ± 0.024 mm.

INSTAR 3.

Prothorax markedly lighter than head and limbs, but latter lighter than in instar two. Meso- and metathorax dark. Abdomen less yellow and red spots only slightly visible on segments 4 and 5.

Antennae becoming elongated.

First wing bud 2 times the length of the visible part of bud 2.

Mean head capsule width 0.85 ± 0.029 mm.

INSTAR 4.

Prothorax as pale as the abdomen. Meso- and metathorax dark.

Abdominal red spots still faintly visible. Last abdominal segment and edges of the sternites darker.

First wing bud greater than five times the length of the visible part of wing bud 2.

Antennae markedly elongate.

Mean head capsule width 1.12 ± 0.041 mm.

INSTAR 5.

More or less unicolorous yellow to brown. Abdominal red spots lost.

First wing bud almost completely covering wing bud two.

Antennae with long terminal arista.

Mean head capsule width 1.48 ± 0.081 mm.

It has been found possible to separate the instars of N.
lineatus using one set of morphological characters; the shape,
size and colour of the wing buds.

4. DURATION OF INSTARS

a) IN THE FIELD

Two methods have been used to calculate the instar durations
from field data.

i. The numbers of each instar per square metre have been recorded
at regular intervals and have been plotted to produce a series of
distribution curves for each instar (Fig. 15). The median value of
each curve was then calculated and the time lapse between one median
and the next is an estimate of the duration of the appropriate instar.
The results are shown in Table 23.

ii. A second method for estimating the duration of insect stadia
from field data is to plot each instar as a percentage of the total
instars in a collection, and measure the time between the peak of
successive curves (e.g. Weaver and King, 1954). The method is
subject to considerable error unless large collections have been
made on each sampling date. Instead of producing a separate curve
for each instar, it is possible to combine the data to produce one
curve from which the instar durations may be estimated (Gabbutt 1959).

FIG. 15 **THE DENSITY OF THE TOTAL POPULATION, AND
OF EACH OF THE NYMPHAL INSTARS OF N.
LINEATUS ON THE JUNCUS SITE IN 1961.**

**The standard errors of the total population
estimates are indicated. The numbered
vertical lines represent the median of each
of the instar distribution curves.**

FIG. 15

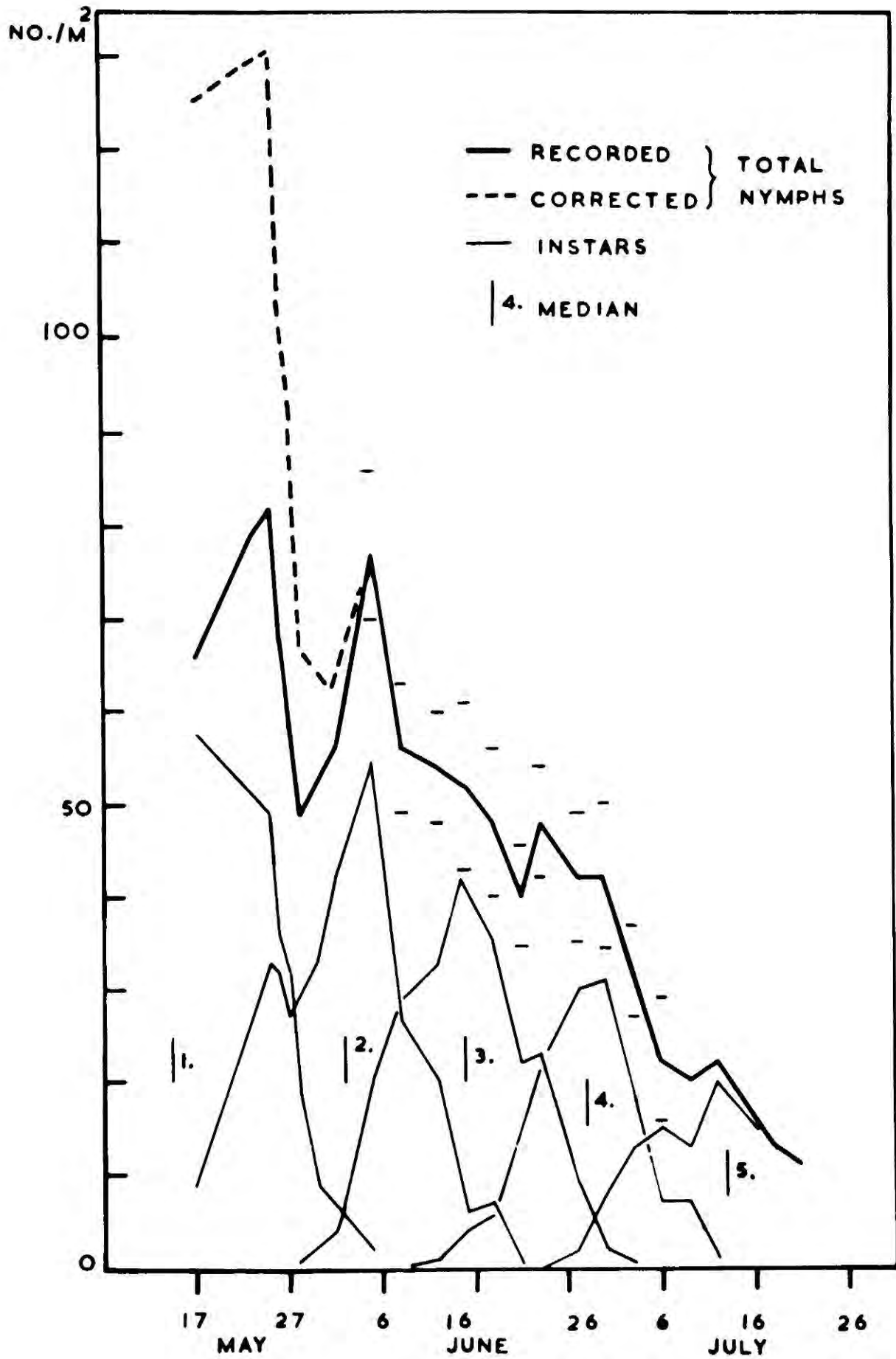

TABLE 22. PERCENTAGE INSTAR COMPOSITION AND MEAN HEAD WIDTHS OF THE 1961 JUNCUS POPULATION

Date	Percentage Instars					Mean Head Width of population (μ).	Total Number of nymphs in sample.
	1	2	3	4	5		
May 17	94	6				480	58
22	77	23				510	53
25	75	25				510	52
28	57	42	1			540	58
June 1	24	69	7			600	101
5	5	70	25			670	154
8	6	43	50	1		730	113
12		38	61	2		770	106
15		13	80	7		840	104
18		16	72	12		850	97
21		4	57	39		950	79
23		3	50	47		970	94
27		1	22	71	6	1080	85
30			6	75	19	1170	83
July 3			2	56	42	1260	64
6				32	68	1360	44
9				34	66	1350	41
12				7	93	1450	43
18				4	96	1460	26
Mean Head width of instars (μ)	470	620	850	1120	1480		

FIG. 16 **GRAPH TO SHOW THE DURATION OF INSTARS OF
N. LINEATUS ON THE JUNCUS SITE IN 1961**

Each point represents the mean head width of the population on a particular sampling date. The horizontal lines are the mean head widths of instars two to five, projected onto this curve.

FIG. 16

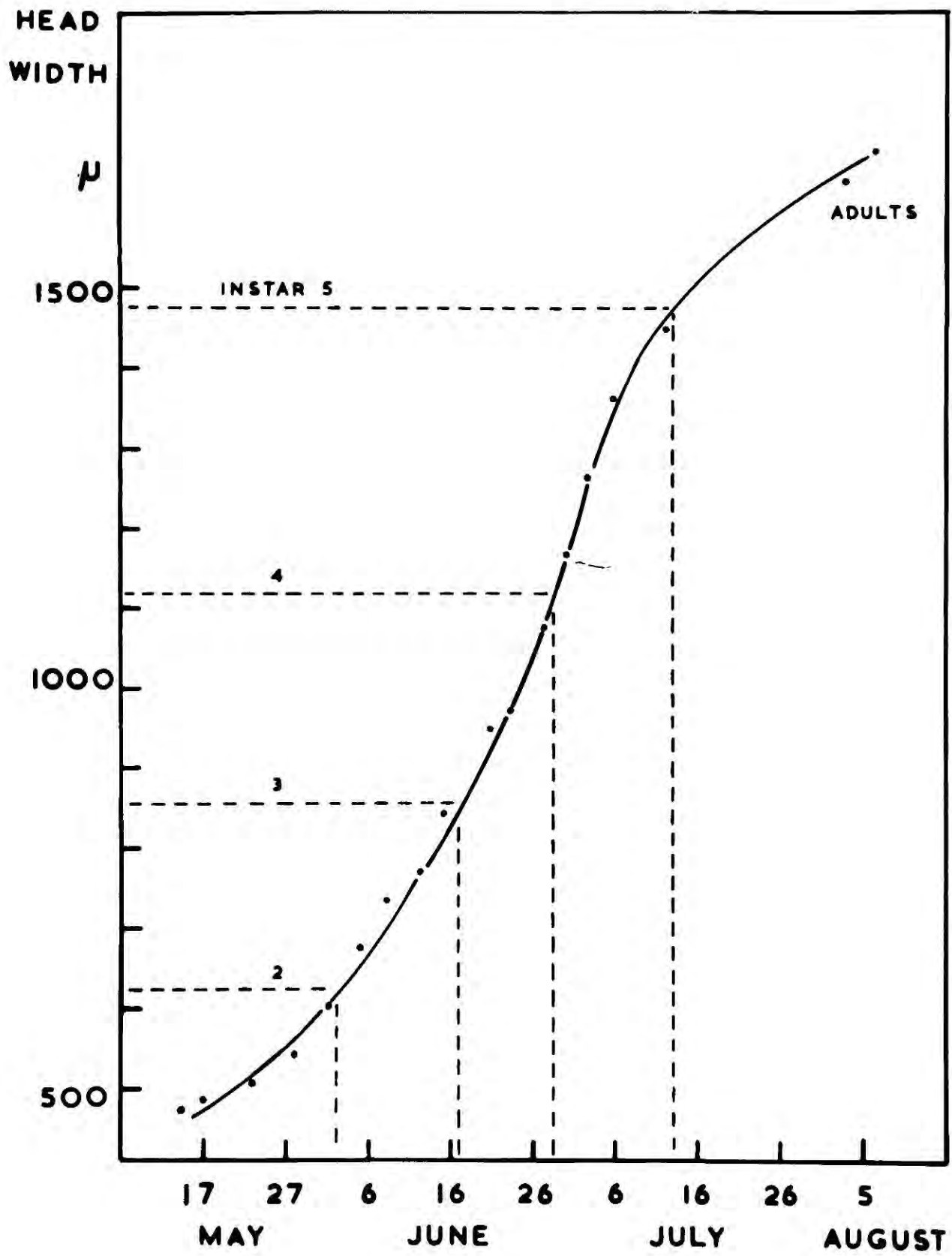

The procedure is as follows:

For each of the sampling dates during the season, a mean head width of all nymphs collected was determined (Table 22). If these are plotted against time, a sigmoid curve results (Fig. 16). The mean head width for a particular collection date depends on the proportions of instars present. Changes in this mean will reflect the growth taking place in the population and so interpolation of the values of mean head widths of successive instars will show the time lapse between those instars. This is so in the case of instars two to five because the effect of the "tails" of the distribution curves of the preceding and succeeding instars tend to compensate each other (see Fig. 15), so that the mean head width of the population is the same as the appropriate instar mean. There is, however, a danger in interpolating the instar one mean head width to estimate the duration of instar one. In this case, the time at which the mean head width equals that of instar one will be when there are only instar one individuals present and no eggs remaining to hatch, (because the number of 'instar nought' individuals (i.e. eggs) which would compensate for the presence of instar two cannot be estimated). Therefore the method has not been used for instar one, but estimates for the other instars are given in Table 23.

TABLE 23. DURATION OF INSTARS OF *N. LINEATUS* AT MOOR HOUSE IN 1961 (DAYS)

INSTAR	1	2	3	4	5
From growth curves:					
a) Head widths		15	12	15	15
b) Tibia length		14	13	15	
c) Wing bud		15	13	18	
From distribution curves	19	14	13	15	

b) THE EFFECT OF TEMPERATURE ON THE DURATION OF INSTAR ONE

i. In the laboratory.

Although laboratory facilities at Moor House are limited, it was possible to rear N. lineatus nymphs up to the second instar by removing squares of Juncus squarrosus turf from the field, and setting them up in the laboratory in polythene containers in which a high humidity was maintained. Five nymphs were successfully reared at different mean temperatures and the number of days spent in instar one are recorded in Table 24.

TABLE 24. THE DURATION OF INSTAR ONE OF N. LINEATUS, IN THE LABORATORY

Mean temperature °C.	Duration (Days $\pm \frac{1}{2}$).
12.5	8
10.8	10
10.6	10
10.6	12
6.8	15

ii. In the field.

An estimate for the duration of instar one in 1961 has already been made (19 days). In 1962, the earliest hatching date was observed (15 May). Second instars had appeared in the population by 1 June, giving an estimate for the duration of instar one of 17 days. In 1963,

FIG. 17 **THE EFFECT OF TEMPERATURE ON THE DURATION
OF INSTAR ONE OF N. LINEATUS**

**Open points are field records and closed
points are from laboratory data.**

($y = 16.23 - 0.521x$).

FIG. 17

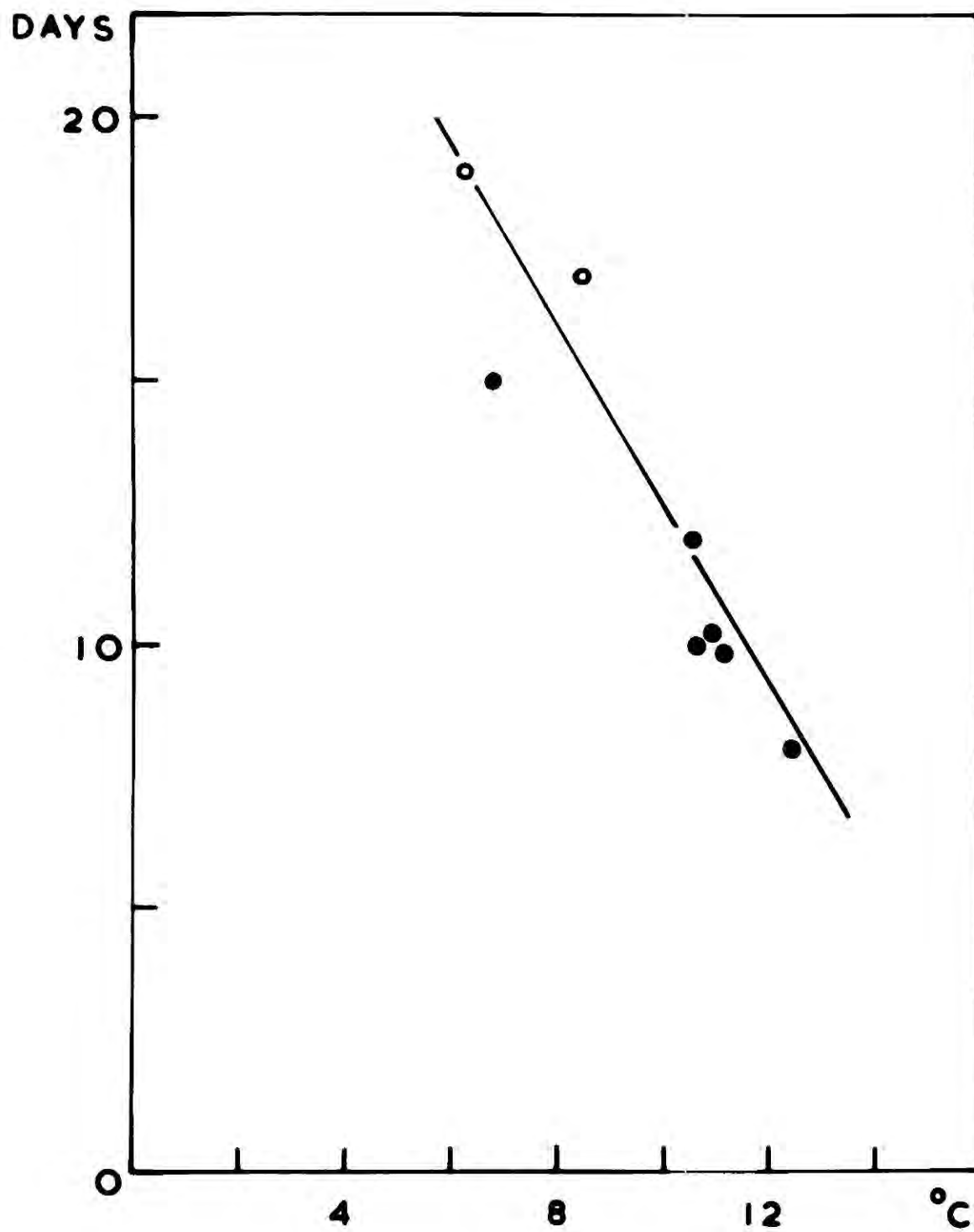

it was possible to obtain a direct estimate of the duration of instar one in the field, because the population was so small that individual nymphs could be labelled on hatching, and their development followed. This was done for 40 nymphs, and the mean duration of instar one was found to be 10 ± 1 days.

These field estimates vary considerably from year to year, because the screen temperatures during the development time of instar one were different. They are recorded in Table 25, and the laboratory and field data has been grouped in Fig. 17 to produce a graph showing the effect of temperature on the duration of instar one. The relationship is approximately linear.

TABLE 25. THE EFFECT OF TEMPERATURE ON THE DURATION OF INSTAR ONE IN THE FIELD

	Mean screen temperature °C	Duration (days)
1961	6.3	19
1962	8.5	17
1963	11.1	10

5. DENSITIES AND COMPOSITIONS OF THE *N. LINEATUS* POPULATIONS

In Tables 26 to 29, the numbers per metre square of each instar are given for both sampling sites in each year, together with the overall densities of animals present with their standard errors. The densities marked * are those to which a correction factor has been

applied assuming only 50% efficiency of sampling instar one.

(See section IV). The corresponding standard errors are bracketed because they have not been corrected.

The Juncus and Nardus populations were both considerably smaller in 1962 than in 1961. In 1963, the populations were even smaller and the Juncus site had only approximately one nymph per square metre at a time corresponding with peak occurrence of instar two (cf. $80/m^2$ in 1961 and $13/m^2$ in 1962). Decreases in the population density were not confined to these two sites. A Juncus area at Nether Hearth (see map) was sampled in 1961 and again in 1963 at a comparable stage in the life history. Numbers per square metre were 26 ± 4 and 2 ± 1 respectively. Similarly, two sampling sites at Dorth Gill (off the Reserve) which had yielded 13 ± 2 and 23 ± 4 nymphs in 1961, had only 4 ± 0.8 and 1.5 ± 0.5 nymphs per metre square respectively, at a comparable time in 1963. A subjective estimate of the numbers of nymphs on the Middle Tongue transect (on the west side of the Reserve) also showed the population density in 1963 to be much less than in 1962. Similar reductions in population densities will later be shown to have occurred in other species of Auchenorrhyncha studied at Moor House.

TABLE 26. THE DENSITY AND COMPOSITION OF THE *N. LINEATUS* POPULATION ON THE JUNCUS SITE IN 1961.

Date	Instar					Adults		Total + per m ² -	Standard Error
	1	2	3	4	5	♂♂	♀♀		
May 17	116*	9						125*	
22	122*	18						140*	
25	123*	20						143*	
27	80*	17						97*	
June 1	26*	38	5					69*	
5	4*	56	20					80*	7.6
8	2*	25	29	1				57	7.0
12		20	33	1				54	6.8
15		7	42	4				53	9.8
18		7	35	6				48	7.8
21		2	22	15				39	5.6
23		1	24	22				47	6.6
27		1	9	30	2			42	7.8
30			3	31	8			42	8.0
July 3			1	18	13			32	5.0
6				7	15			22	4.4
9				7	13			20	4.4
12				2	20			22	5.2
18				1	12			13	3.0
21					10	1		11	3.2
31					4	4	3	11	3.6
Aug. 3					2	6	3	11	3.6
7						2	2	4	1.3
15						3	1	4	1.1
23						1	2	3	1.2
29						1	1	2	0.9
Sept 6						1	0.5	1.5	0.7
11						1	0.5	1.5	0.7

TABLE 27. THE DENSITY AND COMPOSITION OF THE *N. LINEATUS* POPULATION ON THE JUNCUS SITE IN 1962

Date	Instar					Total per m ² ±	Standard Error
	1	2	3	4	5		
May 15	10*					10*	(1.2)
29	14*					14*	(1.6)
June 1	12*					12*	(1.4)
4	12*	1				13*	(1.4)
13	4*	8	1			13*	(1.8)
20		5	5			10	2.1
26		1	6	1		8	1.8
July 3			2	4		6	1.3
12				3	2	5	1.2
19				2	2	4	1.3
25					3	3	1.0
Aug. 1					2	2	0.5

TABLE 28. THE DENSITY AND COMPOSITION OF THE *N. LINEATUS* POPULATION ON THE NARDUS SITE IN 1961

Date	Instar					Total per m ² ±	Standard Error
	1	2	3	4	5		
June 1	48*	30				78*	(8.4)
7	10*	52	25	1		88*	(12.0)
14	4*	17	29	2		52*	(6.8)
20	1*	11	29	8		49*	(8.8)
27		2	7	16	2	27	4.6
July 2			3	19	2	24	5.8
9			1	12	15	28	5.4
14			1	3	16	20	7.8

TABLE 29. THE DENSITY AND COMPOSITION OF THE *N. LINEATUS* POPULATION ON THE NARDUS SITE IN 1962

Date	Instar					Total per m ² ±	Standard Error
	1	2	3	4	5		
May 29	10*					10*	(1.9)
1	12*					12*	(2.1)
7	10*	3				13*	(1.7)
14	8*	10				18*	(3.2)
21	4*	5	6			15*	(2.2)
28		2	5	3		10	2.1
July 4		1	4	4		9	1.7
11			2	3	1	6	1.1
18			1	2	1	4	0.9
24				1	2	3	0.9
Aug 1					2	2	0.8

6. HOST PLANTS OF NYMPHS AT MOOR HOUSE

In addition to the three main host plants already listed (Juncus squarrosus, Festuca ovina and Nardus stricta), records have been made at Moor House of N. lineatus nymphs feeding (i.e. producing spittle) on the following plants at Moor House :

Juncus effusus

Carex spp.

Trichophorum caespitosum

Deschampsia caespitosa

Holcus lanatus

Agrostis tenuis

The record of Trichophorum caespitosum is particularly interesting because Pearsall (1950) points out that records of insects feeding on this species are extremely rare. Spittles of N. lineatus nymphs are by no means rare on this plant at Moor House. Eriophorum angustifolium is the only common herb on the reserve (with the exception of Calluna vulgaris) on which spittles have not been observed. Few insects are known to feed on this plant.

B. THE SPATIAL DISTRIBUTION OF NYMPHS, AND THEIR MORTALITY.

1. INTRODUCTION.

Although large scale patterns of distribution of animals are readily detectable qualitatively (for instance the occurrence of one species of Homoptera on Limestone Grassland but not on Mixed Moor), the more exact detection of non-randomness within small areas requires a quantitative method.

Animal species are subject to a large number of variable environmental factors which together with the biology of the species influence its distribution. The interactions of such factors are many and complex, but in a small enough area of study, it may be expected that many of the factors will be constant in their effect. It may therefore be possible to detect the existence of one or more important factors if they have a disproportionate effect on the local distribution of the species. As Greig-Smith (1957) has pointed out, because most environmental factors do not have random effect, departure from randomness of distribution of a species indicates that one or few factors are influencing its distribution.

The features of the spatial distribution of the nymphs of N. lineatus were studied in order to examine the applicability of this statement to the present problem.

2. STATISTICAL TREATMENT OF THE DATA

The data used to determine the numbers of nymphs present in the field were in the form of groups of randomly distributed sampling units. If the nymphs were distributed randomly in these sample units, the data for each date would be in the form of a Poisson series, providing the number of individuals of the species in the quadrats is low relative to the possible number that could occur.

It is a property of the Poisson series that the variance of the samples should be equal to their mean. Blackman (1942) therefore used the ratio of the variance to the mean as a measure of dispersion:-

$$\frac{S^2}{\bar{x}} \quad \text{or} \quad \sum \frac{(x-\bar{x})^2}{\bar{x}(n-1)} \quad \begin{array}{l} \text{Where } x = \text{number per sample.} \\ \bar{x} = \text{mean number per} \\ \text{sample.} \\ n = \text{number of samples.} \\ S^2 = \text{variance.} \end{array}$$

Departures from unity in this ratio will indicate the presence of regular distribution or aggregation in the population. Aggregations will be indicated by ^aratio greater than unity and regular distribution by a ratio less than unity.

Blackman considered that the departure from unity of the variance : mean ratio in an expected Poisson distribution was significant at the 5 per cent level of probability if the value was greater or less than unity by two standard errors. The standard error is equal to :

$$= \sqrt{\frac{2N}{(N-1)}} \quad \text{Where } N = \text{the number of samples.}$$

It has since been shown by Bartlett (in Greig-Smith 1952a), however, that a more correct value of the standard error is :

$$\sqrt{\frac{2}{N-1}}$$

This equation is used in the present work although for a reasonably large number of samples, there is little difference between the two estimates.

A great deal of confusion has arisen about the terms over - and under - dispersal and they are thus best avoided. In this account the term "aggregation" will be used to signify the tendency of individuals to be clumped, and the variance:mean ratio method of testing this will be referred to as the "coefficient of dispersion" or V/M , although it is recognised that these are not ideal terms.

It may be mentioned that there are several other ways of demonstrating non-randomness in a population, but the one employed and described above seems adequate for the present purpose. It has, however, been criticised on the grounds that it is dependent on the size of the sample used (Skellam, 1952). This is a criticism which may be levelled at all the methods of showing non-randomness in a population. It simply means that the ratio is not an absolute measure of the amount of aggregation, but indicates its presence and allows comparison of different sets of samples of the same quadrat size.

The variance:mean ratio is also incapable of demonstrating certain types of non-randomness; for instance, a situation in which a generally

regular distribution has occasional groups of individuals. This is an uncommon type of distribution in nature, where the most frequent type of non-randomness produces an excess of empty quadrats and quadrats with high numbers of individuals. The test is sensitive to this kind of distribution.

3. THE VARIANCE : MEAN RATIO

The coefficients of dispersion have been calculated for four populations of N. lineatus on each of the sampling dates. In each case, the coefficient was calculated for the total number of nymphs present and also for the total number of spittle-masses present. Tables 30 to 33 list the data for the Juncus and Nardus populations in 1961 and 1962, together with the relevant number of nymphs per spittle (see later).

Forty quadrats were examined on each sampling date so that from Bartlett's equation, the variance:mean ratio departs significantly from unity if it exceeds 1.45 or falls below 0.55. The figures which exceed this value are underlined in the tables. None fell below 0.55.

Although this test of non-randomness has been applied to several animal population studies (e.g. Glasgow, 1939), it has rarely been correlated with the life history studies of the animals themselves. Salt and Hollick (1946) in their study of wireworms, were able to calculate the coefficient of dispersion for different "stages" (defined by arbitrary measurement) in the life history. They found

FIG. 18 DENSITIES OF INSTARS, AND THE COEFFICIENT OF DISPERSION OF *N. LINEATUS* NYMPHS ON THE JUNCUS SITE IN 1961.

The horizontal line marks the point at which the coefficient of dispersion (V/M) differs significantly from unity.

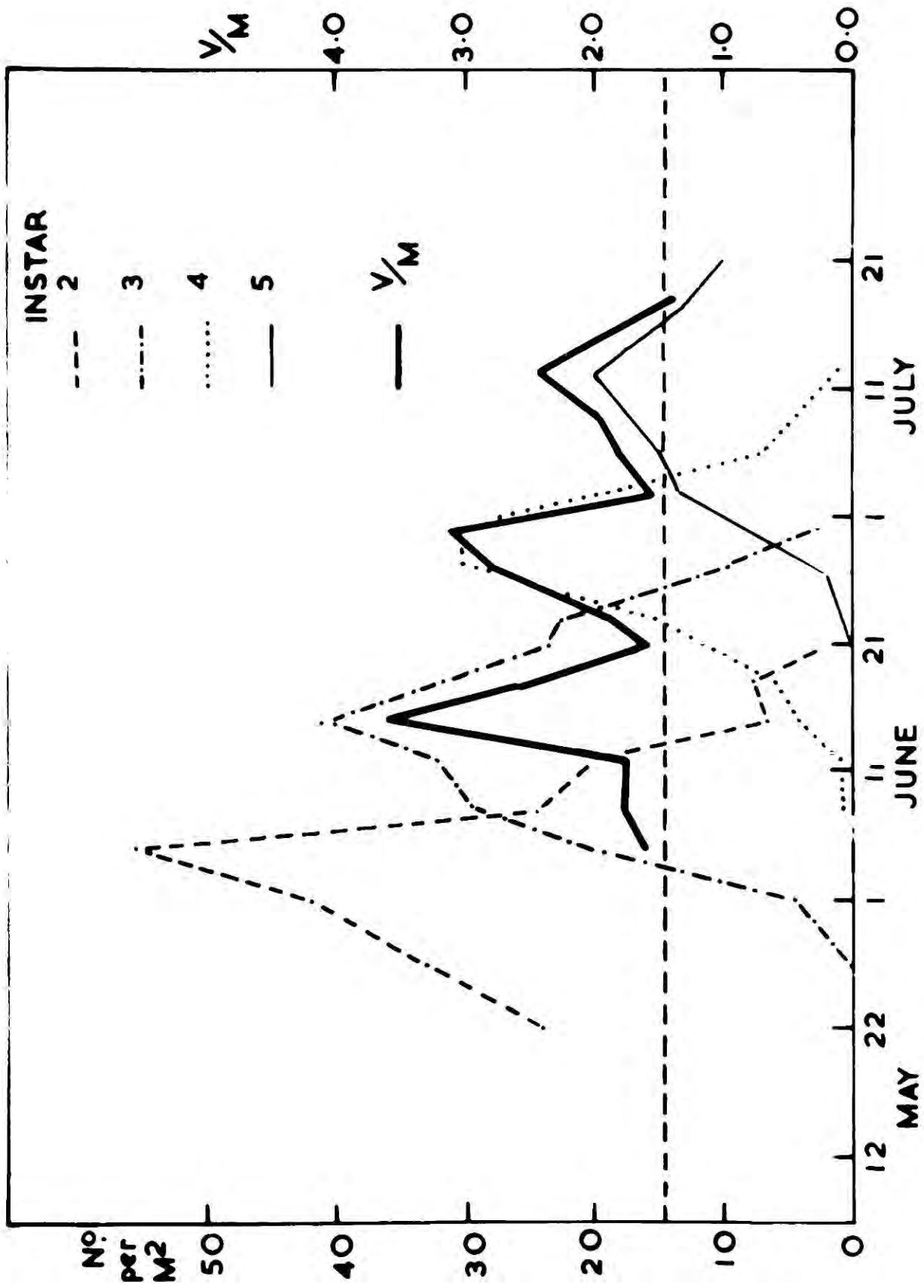

N. LINEATUS ON JUNCUS SITE 1961

FIG. 18A THE COEFFICIENTS OF DISPERSION OF NYMPHS AND SPITTLES OF N. LINEATUS ON THE JUNCUS SITE IN 1961.

The nymphs are represented by the solid line, and the spittles by the broken line. The horizontal line marks the point at which the coefficient of dispersion (V/M) differs significantly from unity. The vertical arrows indicate the peak occurrence of the instars.

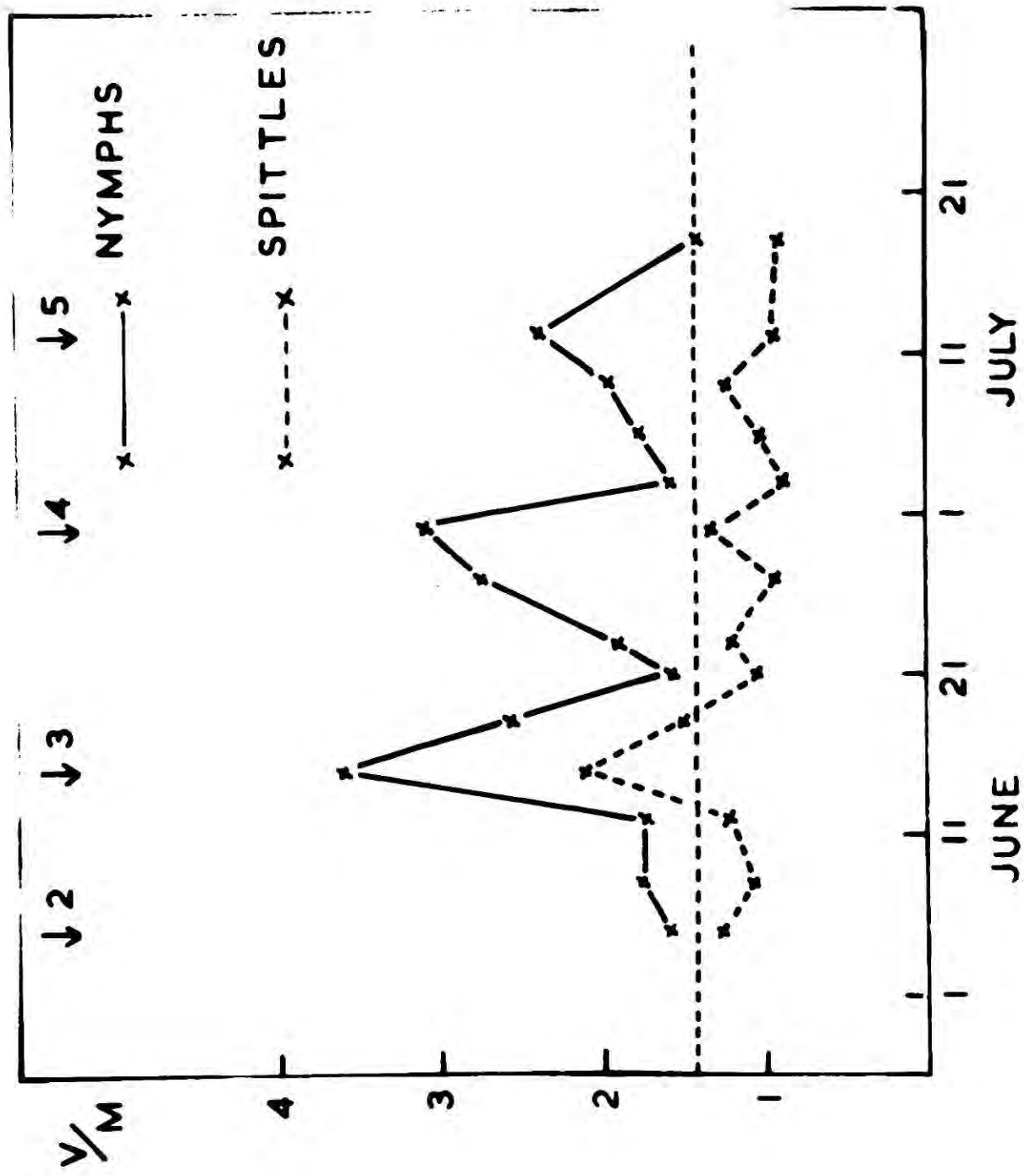

N.LINEATUS ON JUNCUS SITE 1961

that the coefficient was high in small (i.e. young larvae) and became progressively smaller in larger (older) larvae. They concluded that the larvae are gathered together in groups when they are young (because the adults lay eggs in batches) and seem gradually to disperse and to reach a random distribution when they are older.

Female cercopids usually lay eggs in batches, rather than singly, cementing them in clumps in the axils of grass leaves, so it might be expected that they would show similar distribution patterns to the wireworms. This is not the case.

4. VARIATIONS IN THE COEFFICIENT OF DISPERSION OF THE NYMPHS

a) THE JUNCUS SITE

The coefficient of dispersion of the nymphs on the Juncus site throughout their development period, is presented graphically in Fig. 18. The horizontal line marks the point at which V/M differs significantly from unity. The numbers per square metre of each instar present during the nymphal season (with the exception of instar 1) have also been indicated. The thick line represents the coefficient of dispersion of the total numbers of nymphs present. (i.e. in its calculation, no account was taken of the instar composition of the population). In spite of this, it fluctuates with the peaks of instar occurrence, and bears no relation to the total numbers of nymphs present, which diminish throughout the season as shown in Fig. 15. Clapham (1936) has shown that V/M tends to increase with the mean without any real change in the distribution.

TABLE 30. COEFFICIENTS OF DISPERSION AND NUMBER OF NYMPHS PER SPITTLE ON JUNCUS SITE 1961.

Date	Variance of nymphs	Mean of nymphs	V/M of nymphs	Nymphs per spittle	Variance of spittles	Mean of spittles	V/M of spittles
June 5	6.3	3.9	<u>1.56</u>	1.15	4.3	3.4	1.26
8	4.9	2.8	<u>1.75</u>	1.15	2.8	2.5	1.13
12	4.7	2.7	<u>1.74</u>	1.20	2.7	2.2	1.22
15	9.7	2.6	<u>3.74</u>	1.24	4.5	2.1	<u>2.12</u>
18	6.1	2.4	<u>2.54</u>	1.28	2.9	1.9	<u>1.51</u>
21	3.2	2.0	<u>1.60</u>	1.25	1.7	1.6	1.06
23	4.6	2.4	<u>1.92</u>	1.34	2.2	1.8	1.22
27	5.9	2.1	<u>2.80</u>	1.46	1.4	1.5	0.95
30	6.6	2.1	<u>3.14</u>	1.51	1.9	1.4	1.34
July 3	2.5	1.6	<u>1.56</u>	1.39	1.1	1.2	0.88
6	2.0	1.1	<u>1.82</u>	1.33	0.8	0.8	1.03
9	2.0	1.0	<u>2.00</u>	1.46	0.9	0.7	1.26
12	2.7	1.1	<u>2.45</u>	1.43	0.8	0.8	0.95
18	0.9	0.65	1.38	1.18	0.6	0.6	0.93

Coefficients of dispersion showing significant aggregation are underlined.

TABLE 31. COEFFICIENTS OF DISPERSION AND NUMBER OF NYMPHS PER SPITTLE ON JUNCUS SITE 1962.

Date	Variance of nymphs	Mean of nymphs	V/M of nymphs	Nymphs per spittle	Variance of spittles	Mean of spittles	V/M of spittles
May 15	0.61	0.47	1.29	1.12	0.51	0.43	1.18
29	0.84	0.70	1.20	1.11	0.65	0.63	1.04
June 1	0.86	0.63	1.37	1.25	0.51	0.50	1.03
4	0.76	0.75	1.01	1.11	0.58	0.68	0.86
13	1.26	1.15	1.10	1.02	1.19	1.13	1.05
20	1.77	1.00	<u>1.77</u>	1.15	1.05	0.85	1.24
26	1.37	0.75	<u>1.83</u>	1.36	0.56	0.55	1.02
July 3	0.76	0.58	1.31	1.05	0.41	0.48	0.85
12	0.61	0.43	1.42	1.19	0.33	0.33	1.00
19	0.51	0.45	1.13	1.07	0.35	0.40	0.88
25	0.46	0.28	<u>1.64</u>	1.22	0.28	0.23	1.22

Coefficients of dispersion showing significant aggregation are underlined.

FIG. 19 THE COEFFICIENTS OF DISPERSION OF NYMPHS
AND SPITTLES OF *N. LINEATUS* ON THE JUNCUS
SITE IN 1962.

Key as for Fig. 18A.

FIG. 19

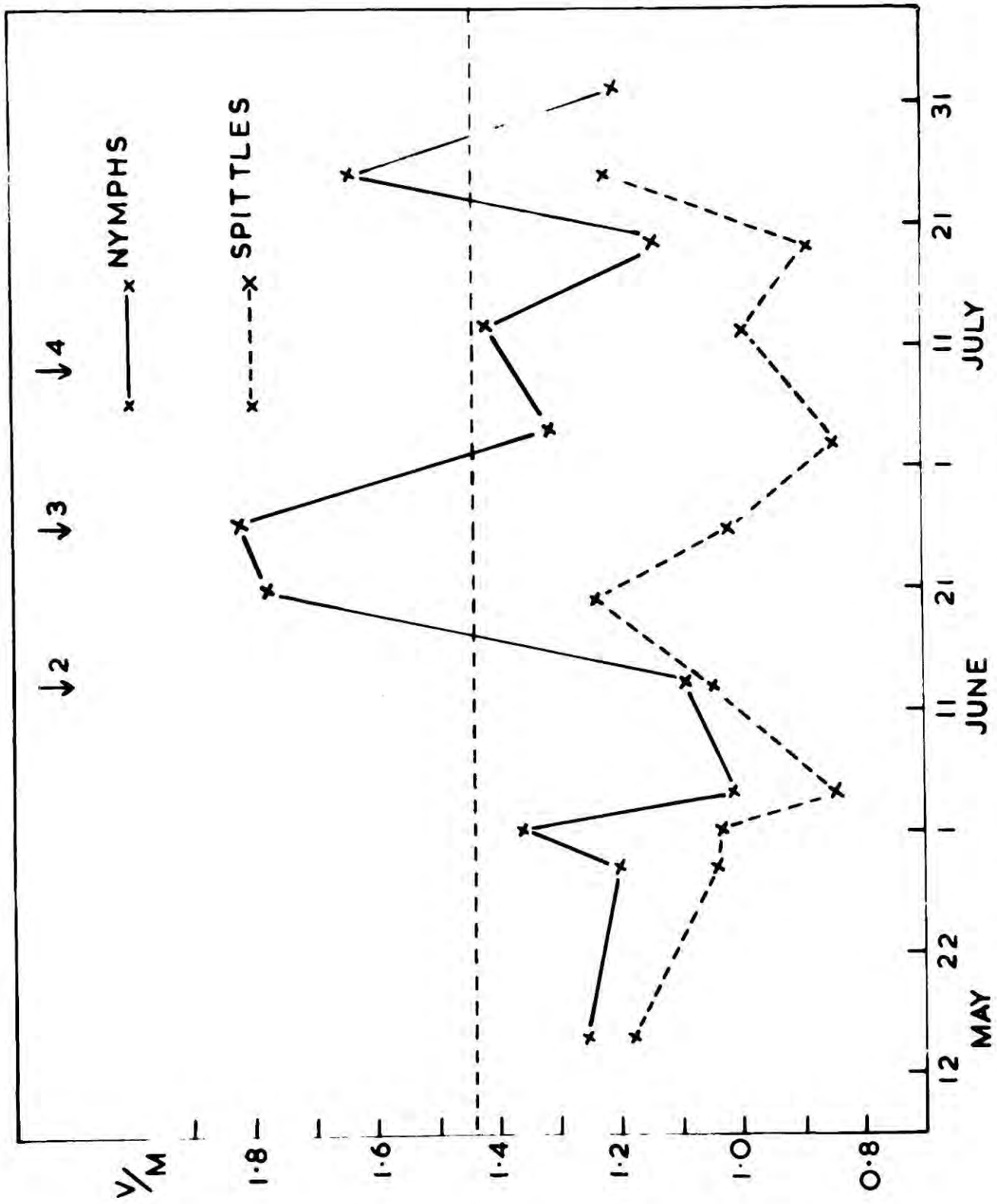

N. LINEATUS ON JUNCUS SITE 1962

It might be expected that the coefficient of dispersion would decrease as the total number of nymphs diminishes, or as any initial aggregation, due to the habit of laying eggs in batches, breaks down as the later instars disperse. It will later be shown (section VII) that such a decrease in V/M with the mean does occur in another cercopid studied (N. exclamationis), probably for one of the above reasons. The same general trend seems to be present on the Juncus and Nardus sites and is evident in the fact that the peaks of the coefficient of dispersion curves tend to be lower as the population densities diminish. This cannot account for the fluctuations in V/M corresponding with the peaks of instar occurrence.

There is no evidence of significant aggregation on 5 June when the 2nd instars are at maximum occurrence, but the peaks of instars 3, 4 and 5 all correspond with a high variance:mean ratio.

In 1962, the same situation was found on the Juncus site (Fig.19) even though the population density was only about one fifth of the previous seasons numbers. In this graph, the coefficient of dispersion of the nymphs is shown by the solid line, and the peaks of occurrences of the instars are indicated by the numbered arrows. As in 1961, there is no evidence of aggregation associated with the second instar, but only with the later ones.

b) THE NARDUS SITE

Corresponding data from the Nardus site show similar variations in the coefficient of dispersion in both years, although in this

TABLE 32. COEFFICIENTS OF DISPERSION AND NUMBERS OF NYMPHS PER SPITTLE ON NARDUS SITE 1961.

Date	Variance of nymphs	Mean of nymphs	V/M of nymphs	Nymphs per spittle	Variance of spittles	Mean of spittles	V/M of spittles
June 1	7.2	2.3	<u>3.13</u>	1.09	4.5	2.1	<u>2.14</u>
7	15.0	4.4	<u>3.41</u>	1.14	7.6	3.6	<u>2.11</u>
14	4.6	2.5	<u>1.84</u>	0.93	4.9	2.7	<u>1.81</u>
20	7.6	2.4	<u>3.17</u>	1.16	5.4	2.1	<u>2.57</u>
27	2.1	1.4	<u>1.55</u>	0.96	1.8	1.4	1.29
July 2	3.6	1.2	<u>3.00</u>	0.98	4.0	1.2	<u>3.34</u>
9	2.9	1.4	<u>2.07</u>	1.14	1.5	1.2	1.18
14	3.2	1.0	<u>3.15</u>	1.18	1.5	0.9	<u>1.76</u>

Coefficients of dispersion showing significant aggregation are underlined.

TABLE 33. COEFFICIENTS OF DISPERSION AND NUMBERS OF NYMPHS PER SPITTLE ON NARDUS SITE 1962.

Date	Variance of nymphs	Mean of nymphs	V/M of nymphs	Nymphs per spittle	Variance of spittles	Mean of spittles	V/M of spittles
June 1	1.35	0.60	<u>2.30</u>	1.06	1.15	0.57	<u>2.02</u>
7	1.19	0.70	<u>1.70</u>	1.12	0.86	0.63	1.37
13	4.35	1.40	<u>3.11</u>	1.06	3.40	1.33	<u>2.56</u>
21	2.01	1.20	<u>1.68</u>	0.96	2.14	1.25	<u>1.71</u>
27	1.92	1.00	<u>1.92</u>	0.91	2.00	1.13	<u>1.77</u>
July 4	1.17	0.90	1.30	1.10	1.49	1.00	<u>1.49</u>
11	0.66	0.48	1.40	0.95	0.56	0.48	1.17
18	0.38	0.32	1.19	0.93	0.34	0.35	0.97
24	0.58	0.33	<u>1.76</u>	0.92	0.44	0.35	1.26
Aug. 1	0.33	0.23	1.43	1.00	0.33	0.23	<u>1.45</u>

Coefficients of dispersion showing significant aggregation are underlined.

FIG. 20 **THE COEFFICIENTS OF DISPERSION OF NYMPHS
AND SPITTLES OF N. LINEATUS ON THE NARDUS
SITE IN 1961.**

Key as for Fig. 18A.

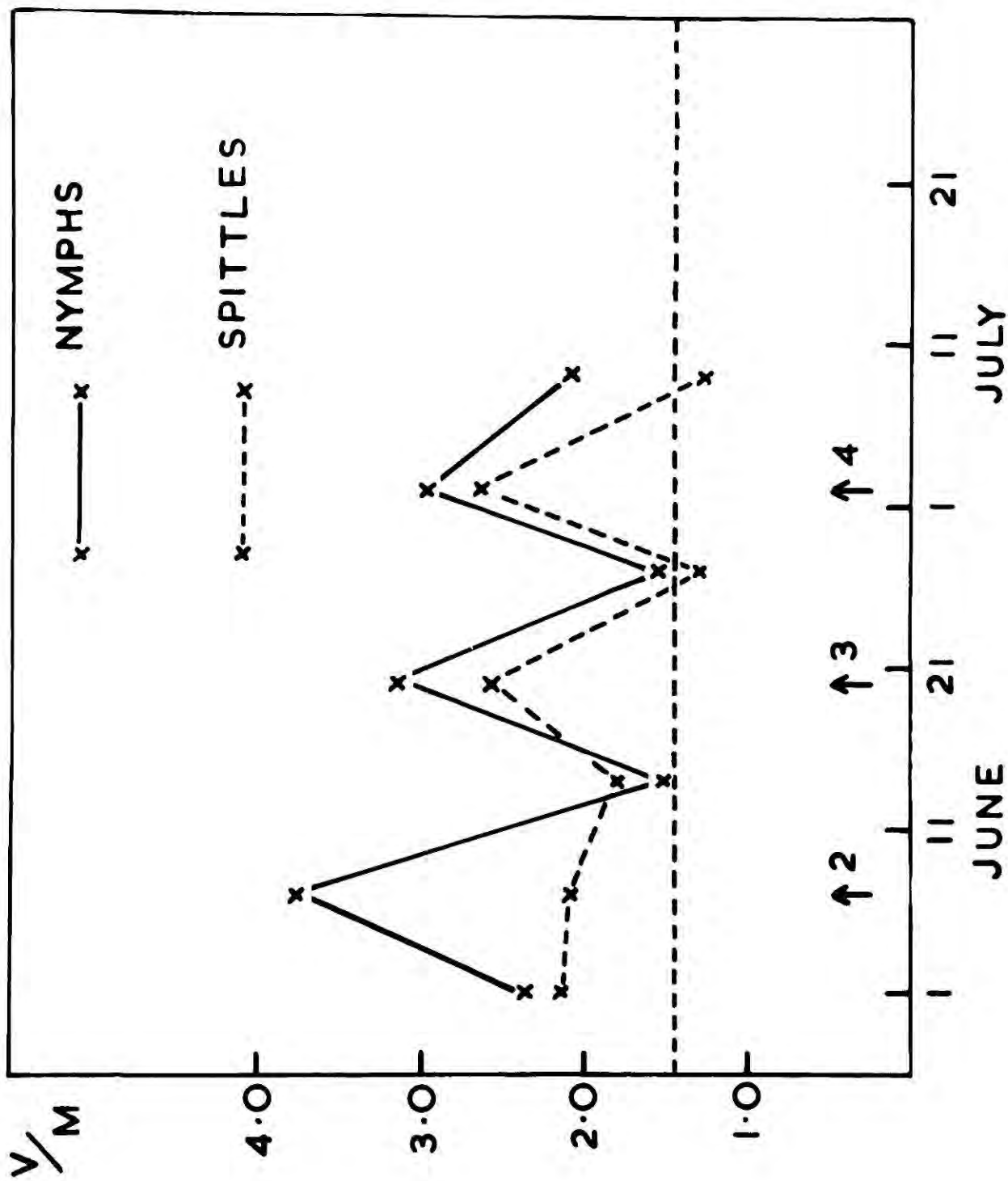

N. LINEATUS ON NARDUS SITE 1961

**FIG. 21 THE COEFFICIENT OF DISPERSION OF NYMPHS
AND SPITTLES OF N. LINEATUS ON THE NARDUS
SITE IN 1962.**

Key as for Fig. 18A.

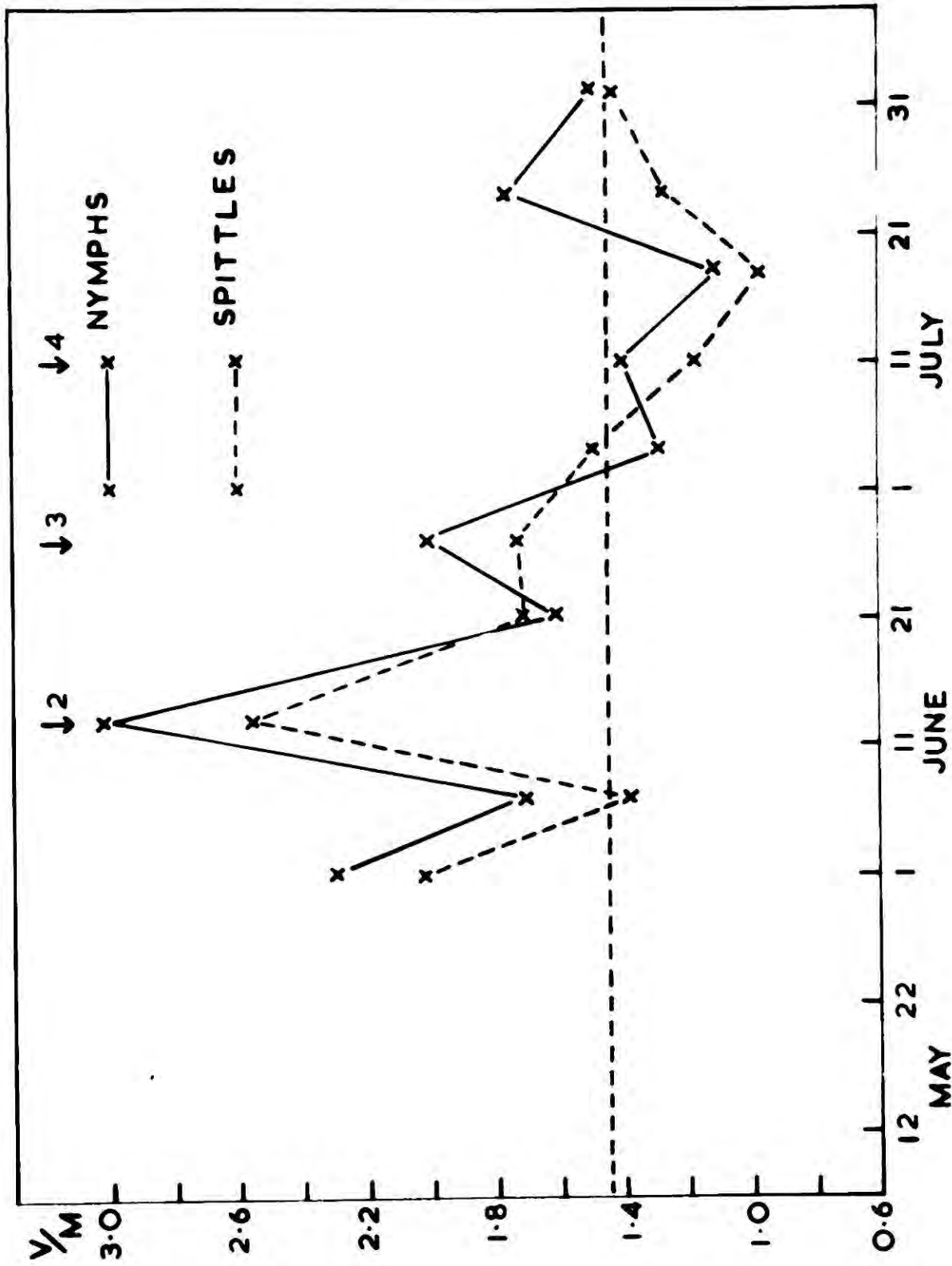

N. LINEATUS ON NARDUS SITE 1962

case there is a peak corresponding with the second instar, as well as with the later ones (Figs. 20 and 21). The population density on the Nardus site in 1962 was also only about 20 per cent of the 1961 numbers.

The actual values of the coefficients on the two sites are not comparable in the two years because the quadrat size was doubled in 1962 to facilitate sampling a low density population. This is not important, however, as the interest in the data rests on the nature of the fluctuations (which do bear comparison) and not on their finite size.

5. VARIATIONS IN THE COEFFICIENTS OF DISPERSION OF THE SPITTLES

Tables 30 to 33 show that in addition to the variation in the coefficients of dispersion of nymphs, their spittle masses also show differences in the variance:mean ratios. When plotted on the same graph as the nymphal data, however, certain discrepancies are apparent:-

a) THE JUNCUS SITE (Figs. 18A, 19).

Whilst the nymphs (solid lines) on the Juncus site show highly significant aggregation at the peaks of instars 3, 4 and 5, the spittles (dotted lines) are aggregated on only two sampling dates in 1961 (associated with the peaks of instar three), and are never significantly aggregated in 1962.

In both graphs therefore, the two coefficient of dispersion lines are widely separated because the aggregation of nymphs is not due solely to the aggregation of the spittles on their host plants. This is in contrast to the situation on the Nardus site.

b) THE NARDUS SITE (Figs. 20, 21).

In 1961 on the Nardus site, the two coefficients of dispersion (nymphs and spittles) are similar (with the exception of one point at 7 June - caused by the fact that on this sampling date, an unusually large number of empty spittles were found). There is therefore very little difference in the degrees of aggregation of the nymphs and spittles. A similar correspondence is seen in the 1962 Nardus data.

6. THE SPITTLE/NYMPH RATIO.

The nymphs on the Juncus site show a greater degree of aggregation than do the spittles because some spittles contain more than one nymph. Whereas the number of nymphs in each spittle did not differ markedly from unity in the Nardus population in either year (it fluctuated between 0.9 and 1.10), in the Juncus population it reached as high as 1.5 animals per spittle. This is a mean of the spittles sampled from each quadrat - in fact, one spittle contained five individuals. The level of aggregation of nymphs in spittles does not remain constant, (Figs. 22, 24) but it rose at the same time as the percentage of nymphs found on Juncus squarrosus increased (Figs. 23, 25), and those

FIG. 22 **THE NUMBERS OF NYMPHS OF N. LINEATUS
PER SPITTLE ON THE JUNCUS SITE IN 1961.**

FIG. 23 **THE PERCENTAGE OF NYMPHS OF N. LINEATUS
OCCURRING ON JUNCUS SQUARROSUS IN 1961,
AND THE OCCURRENCE OF INSTARS FOUR AND
FIVE.**

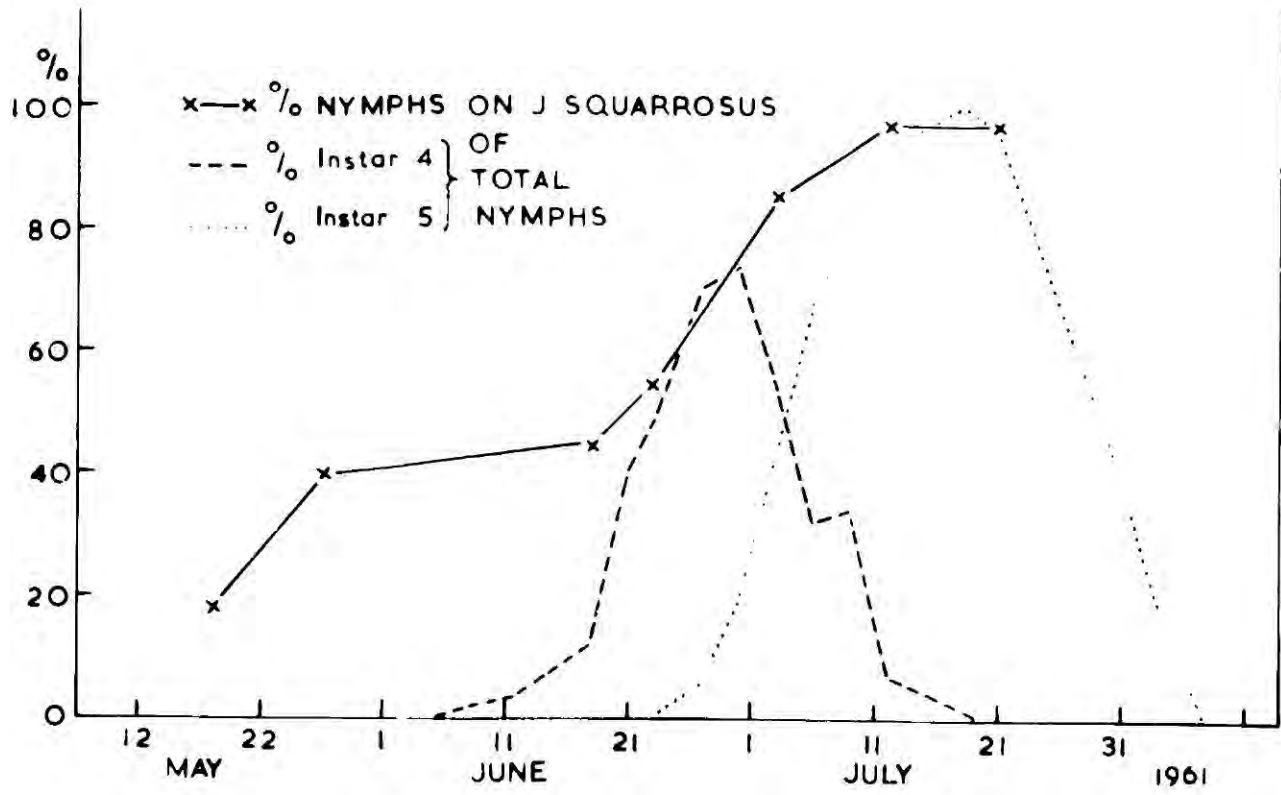
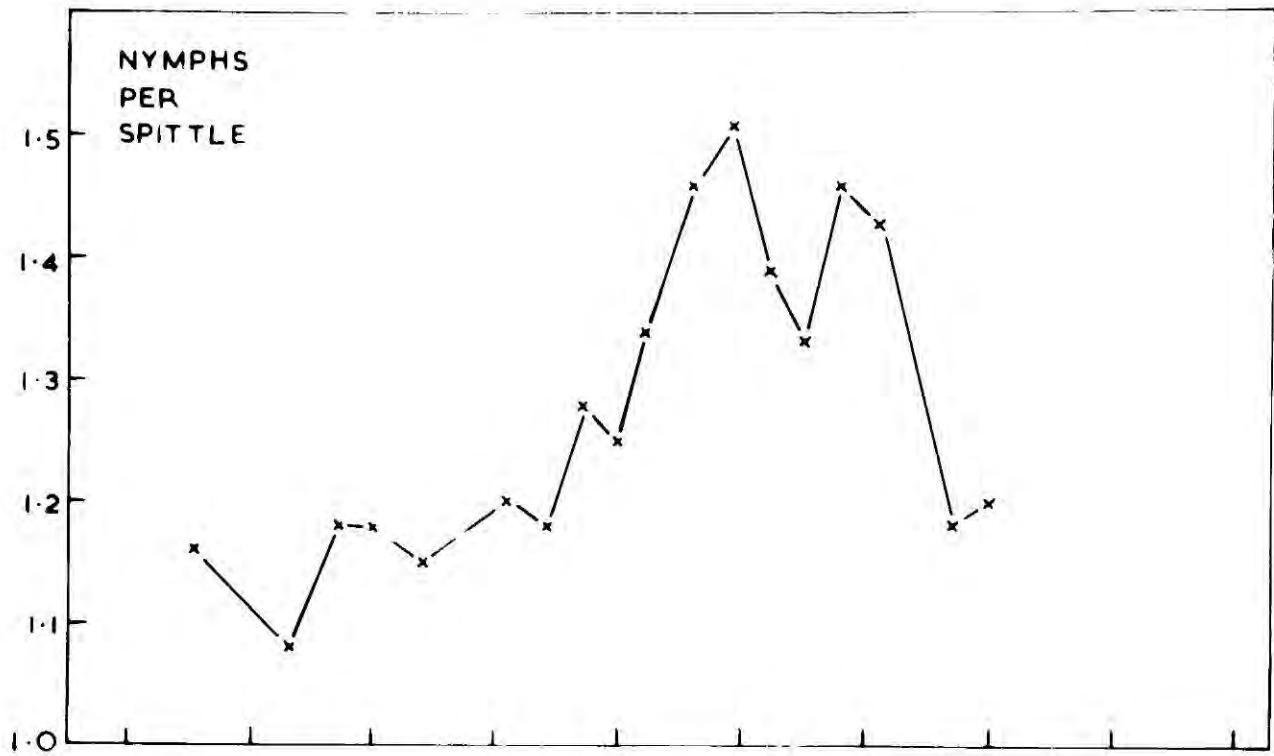
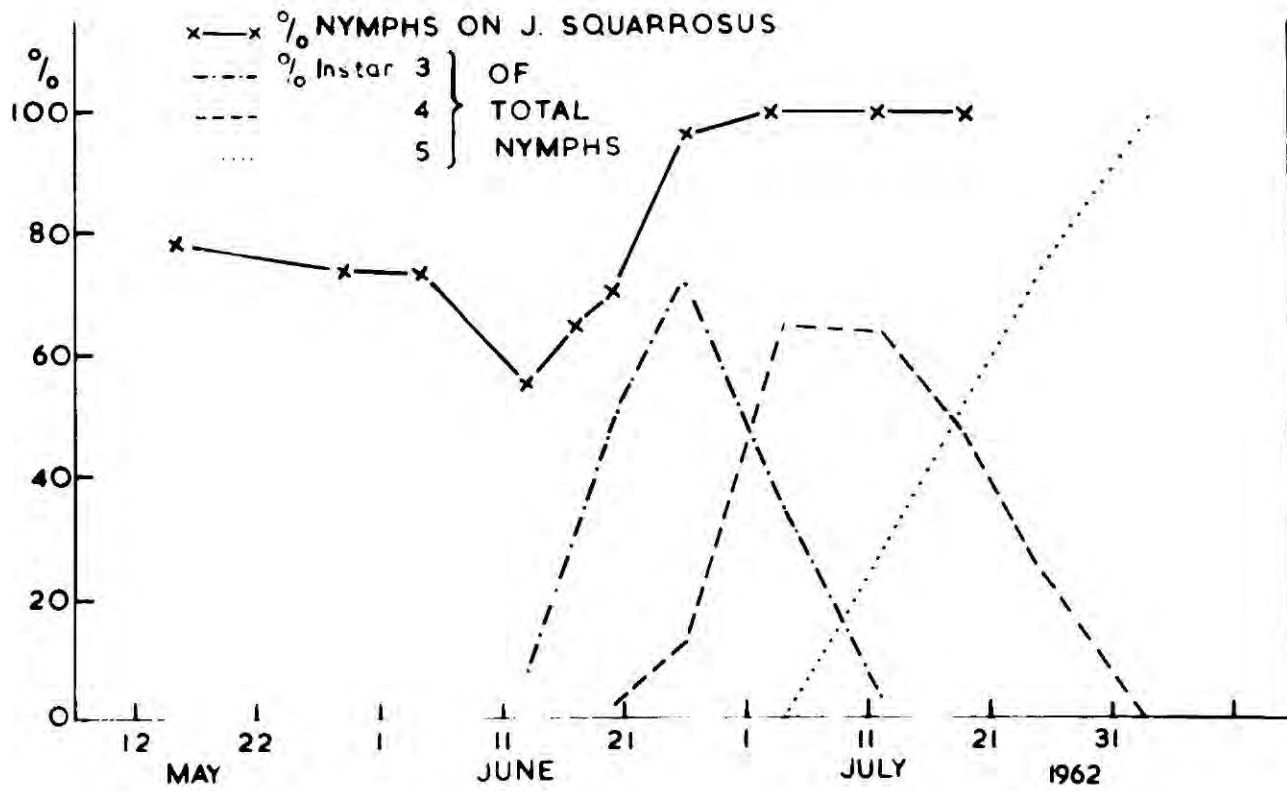
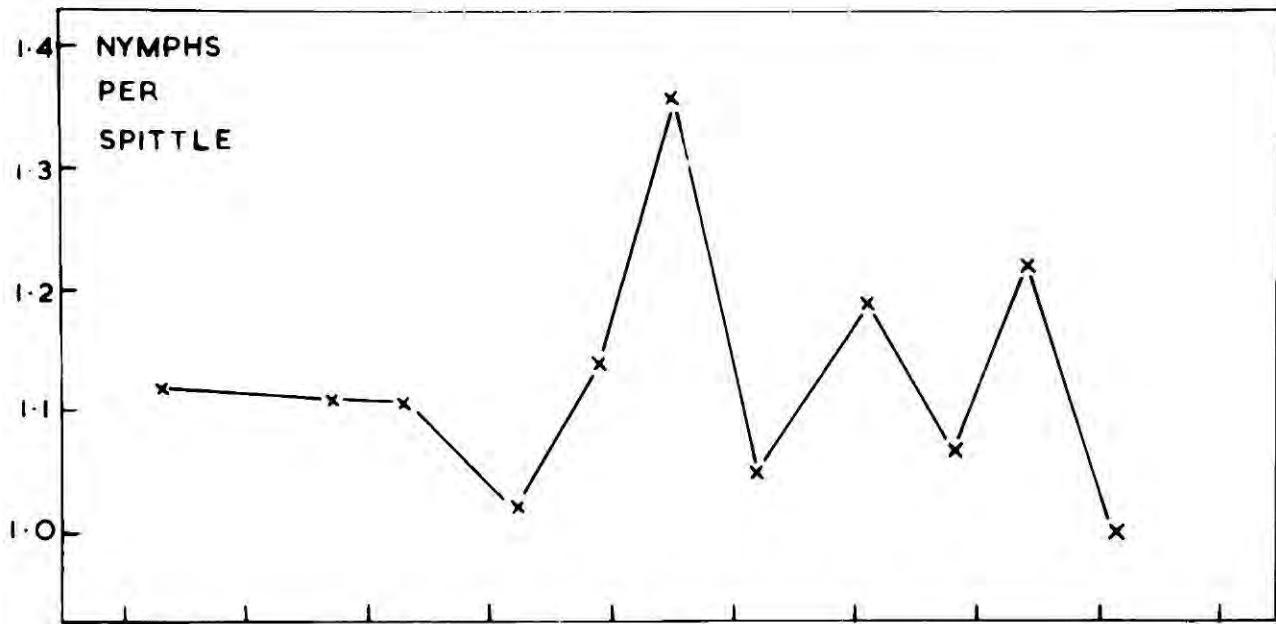

FIG. 24 **THE NUMBER OF NYMPHS OF N. LINEATUS
PER SPITTLE ON THE JUNCUS SITE IN
1962.**

FIG. 25 **THE PERCENTAGE OF NYMPHS OF N. LINEATUS
OCCURRING ON JUNCUS SQUARROSUS IN 1962,
AND THE OCCURRENCE OF INSTARS THREE,
FOUR AND FIVE.**



on Festuca decreased. These two plants are the only important hosts of N. lineatus on the Juncus site at Moor House. It will be shown later that this increase in percentage on Juncus is due to a move of nymphs from Festuca to Juncus, and to a greater mortality of those nymphs which remain on Festuca.

a) THE SITUATION IN 1961 (Figs. 22, 23).

In 1961, the peaks in Spittle/nymph ratio and percentage of nymphs on Juncus corresponded with the time that the numbers of instar 4 in the population increased. Having reached its maximum, the spittle/nymph ratio fluctuated with the instar composition as did the coefficient of dispersion.

b) THE SITUATION IN 1962 (Figs. 24, 25).

In 1962, the rise in spittle/nymph ratio again corresponded with the rise in percentage of nymphs on Juncus squarrosus, and again it fluctuated with the instar composition after reaching its maximum. The rise in this year, however, corresponded with the 3rd, not the 4th instar.

The graphs (Figs. 24, 25) differ from those for 1961 in that both the percentage of nymphs on Juncus and the spittle/nymph ratio have quite high values at the beginning of the season (instar 1). They then fall during instar 2 and begin to rise again in instar 3. Thus although the 1961 population had a high percentage of instar 1 nymphs on Festuca (60 - 80 per cent), in 1962 there were more instar

1 nymphs on Juncus than on Festuca. These figures probably represent the hatching distribution. It has been shown that cercopid eggs require a high temperature and a high humidity for hatching to occur (Weaver and King, 1954). The temperatures of late May and early June were sufficient in both 1961 and 1962 to initiate hatching, and in 1961, both the Festuca and Juncus were sufficiently moist for hatching and feeding of instar one. In 1962, on the other hand, late May and early June was an exceptionally dry period and the humidity at the base of the Juncus rosettes was markedly higher than at the axils of the Festuca (See Table 15). Therefore it is unlikely that eggs laid on the Festuca would hatch, or that first instars would find sufficient nutriment in the parched Festuca plants. The percentage of first instars on Juncus was therefore higher than in the previous year. When the dry spell was broken, eggs were able to hatch, and nymphs were able to feed on the now moistened Festuca, causing a decrease in the percentage of nymphs occurring on Juncus. The relatively impoverished Festuca (as a result of the lack of rain) could presumably only support instars one and two (for one of the reasons advanced in the next section) and so the increase in the percentage of nymphs on Juncus occurred earlier (instar three) than in 1961, when the Festuca was much more luxuriant.

The differences between the coefficients of dispersion of the nymphs and spittles on the Juncus site is due to the presence of more than one nymph in some of the spittles. This is a phenomenon which is associated with the Juncus site and not the Nardus site. Moreover,

it only occurs on the Juncus site when a high proportion of the nymphs are feeding on Juncus squarrosus rather than Festuca (normally the later instars only). In the event of an early instar occurring on Juncus, (e.g. the first instar in 1962), the tendency to aggregate within spittles is present, and is reflected in a small peak in the coefficient of dispersion corresponding with instar one (Fig. 19).

Spittles proved to be surprisingly durable in heavy rain and there was no correlation between the increase in the spittle/nymph ratio and heavy rainfall, which might have been expected to wash spittles together. In spite of the stated views of Weaver and King (1954), and Everly (1959), that aggregation of Philaenus spumarius nymphs within spittles is associated with high population densities, no evidence of this was found in Neophilaenus lineatus at Moor House. The correlation coefficient of the spittle/nymph ratio and the density of nymphs was negative ($r = - 0.45$ with 12 degrees of freedom, $P > 0.1$). A similar analysis carried out on Everly's original data showed only a moderately positive correlation ($r = + 0.57$ with 14 degrees of freedom, $P < 0.02$), so that their views may be an oversimplification.

7. THE NATURE OF THE INCREASE IN PERCENTAGE OF NYMPHS ON JUNCUS

An increase in the percentage of nymphs occurring on Juncus rather than Festuca could be due either to a positive move from one host to the other, or to a differential mortality on the two hosts.

From the 1961 data, 60 per cent of the nymphs were on Festuca on 27 May, whereas less than 20 per cent were on Festuca on 1 July. On 27 May there were 66 nymphs per square metre and by 1 July this had been reduced to 39 (about 40 per cent mortality). This could just be accounted for on the basis of differential mortality if it all occurred to nymphs on Festuca. This is unlikely. Similarly, in 1962, the fall in percentage of nymphs on Festuca from 55 per cent on 13 June to 0 per cent on 3 July could be accounted for solely on the basis of a fall in numbers of from 11.5 per square metre to 5.0 (52 per cent mortality). Both these conclusions would, however, require the assumption of almost 100 per cent survival of the nymphs on Juncus squarrosus. Two experiments were devised to investigate this situation :

i. The marking of nymphs.

On 15 June 1962, 46 spittles were marked with plant labels and the hosts on which they occurred were recorded. The spittles were then re-visited at intervals of a few days and change of host or mortality was recorded. The information is summarized in Table 34.

TABLE 34. THE SURVIVAL OF LABELLED NYMPHS ON THE JUNCUS SITE, 1962

	Number recorded on 15 June	Number on same host on 12 July	Number dead by 12 July	% dead	Number moved to Juncus by 12 July	% moved to Juncus
Juncus	31	20	11	35	0	0
Festuca	15	0	10	66	5	33

The total mortality in this period cannot therefore be accounted for solely by deaths of nymphs on Festuca, because the density^{of} nymphs on Juncus dropped markedly, even though some of the nymphs actively changed hosts from Festuca to Juncus.

ii. Experimental populations.

An experiment in which instar 3 nymphs were restricted to either Festuca or Juncus was set up. This experiment will be discussed at greater length in the section on nymphal mortality (sub-section II) but it is sufficient to note that the mortality was significantly higher on Festuca than on Juncus, although there was a considerable mortality in both cases.

It seems likely that the increase in percentage of nymphs on Juncus squarrosus is due to a combination of two factors: Nymphs which do not move from Festuca in the third or fourth instar are unlikely to survive, but some of those which do move, will succeed in re-establishing themselves on Juncus.

8. REASONS FOR THE MOVE FROM FESTUCA TO JUNCUS.

It seems unlikely that there is a phyto-chemical change in host preference in different instars, because each instar has been found to occur on a variety of different hosts, and has therefore no strict host preference. It is suggested that the more favourable^{nature} of Juncus as a host for later stages is due principally to an increase in the size of the mouthpart stylets, which makes it impossible for them to

be inserted into the very fine leaves of Festuca. The nymphs would thus have to move onto larger hosts (Juncus) or die. Nuorteva (1952) has shown a correlation between the size of leafhoppers and the tissues which they suck. Perhaps it is significant that adults of a closely related species of cercopid, Neophilaenus exclamationis which can complete its life cycle on Festuca at Moor House, have smaller mouth parts than those of the 4th instar of N. lineatus (the instar at which the move onto Juncus usually occurs). Measurements of the stylet lengths of the two species are recorded in Table 35.

Nardus stricta is intermediate in size between Festuca and Juncus squarrosus, and N. lineatus can complete its life cycle on this host.

TABLE 35. MEAN AND STANDARD DEVIATIONS OF STYLET LENGTHS

	Instar of <u>N. lineatus</u>					Adult
	1	2	3	4	5	<u>N. exclamationis</u>
Mean stylet length (mm.)	0.25	0.38	0.44	0.55	0.66	0.54
	\pm	\pm	\pm	\pm	\pm	\pm
	0.015	0.016	0.014	0.020	0.019	0.016

9. CONCLUSIONS

The plants on which the nymphs occur are themselves aggregated with respect to the sample size used (e.g. Juncus squarrosus had a mean of 3.4 rosettes per quadrat and a variance of 7.3 in 1962). This is also the case on the Nardus site because Nardus is usually

aggregated due to its rhizomatous method of spread (Chadwick 1960). The aggregations of nymphs and spittles in 1961 and 1962 on this site are probably due to this reason. The fluctuations in the degrees of aggregation as measured by the coefficient of dispersion must, however, be due to the movement of nymphs (since the host plants remain stationary). They cannot be due simply to a change in density, because although mortality could account for changes in the coefficient in one direction, it could not conceivably account for fluctuations of the type recorded.

The aggregations of instar three nymphs in 1961 on Nardus will be broken down as they moult to instar four, if each instar has different feeding preferences (either different hosts or feeding sites on the same hosts). Thus the nymphs causing the aggregation would move to another feeding site after moulting and begin to cause a second, independent aggregation. This will lead to a high coefficient of dispersion again (the condition at the next peak) when all the nymphs have moulted to instar four, and moved. During the move, nymphs will tend to be more randomly distributed and V/M will have a lower value.

Independent aggregations of the instars are traceable in the sampling data. Table 36 shows the variance and mean of instars four and five on the Juncus site 1961, treated independently. Each instar shows an independent build up in the coefficient of dispersion corresponding with the peaks in Fig. 18 (calculated from total numbers

TABLE 36. COEFFICIENTS OF DISPERSION OF INSTARS FOUR AND FIVE

JUNCUS SITE 1961.

Date	Variance of nymphs	Mean of nymphs	V/M of nymphs
INSTAR FOUR			
June 18	0.32	0.30	1.06
21	1.36	0.78	<u>1.74</u>
23	1.96	1.10	<u>1.78</u>
27	2.77	1.50	<u>1.85</u>
30	3.33	1.60	<u>2.08</u>
July 3	1.53	0.90	<u>1.70</u>
6	0.39	0.35	1.11
9	0.28	0.35	0.81
INSTAR FIVE			
June 27	0.16	0.13	1.23
30	0.76	0.40	<u>1.90</u>
July 3	0.89	0.68	1.31
6	1.22	0.75	<u>1.63</u>
9	1.35	0.68	<u>1.99</u>
12	2.67	1.00	<u>2.67</u>
18	0.75	0.63	1.19

Coefficients of dispersion showing significant aggregation
are underlined.

of nymphs). Independent behaviour of separate instars is therefore sufficiently well marked to be apparent in statistical examination of the total numbers of nymphs.

It is the nymphs which move and not their spittles (these are left behind and a new one formed). Nevertheless, if each nymph which moves re-establishes its own spittle, the coefficient of dispersion of the nymphs and spittles will correspond as they did on the Nardus site in both years. But if the host is a particularly favourable one (e.g. Juncus squarrosus by comparison with Festuca and Nardus, it is possible for more than one nymph to feed at the same place. It has been suggested that there is a definite physiological advantage in this because the concentration of proteinaceous substances and carbohydrates in plants is increased in the vicinity of Homoptera feeding punctures (Tanada and Holdaway 1954; Kloft 1957, 1960a). Old lesions are also known to attract Homoptera (Nuorteva 1962). Weaver and King (1954) are of the opinion that the tendency of nymphs of Philaenus spumarius to aggregate within spittle masses is a characteristic of high infestations. It is not simply a question of overcrowding in the present case, however, because it occurred in 1962 when the population was only approximately one fifth of the density of the 1961 populations.

Aggregations of this type, for whatever reason, are seen on Juncus squarrosus where there is a tendency for nymphs to aggregate within spittles. In such a case, the coefficient of dispersion of the spittles does not correspond with that for the nymphs. The

nymphs show the usual fluctuations in the coefficient to correspond with the instars, but the spittle fluctuations are much less pronounced. Presumably the aggregations of nymphs within spittles is of advantage (see above) to the nymphs but it can only occur on sufficiently nutritive hosts. On the sites studied at Moor House, it seems that only Juncus squarrosus fulfils these requirements and is normally only utilised by the later instars.

It has been argued (Greig-Smith 1957) that the use of Poisson distributions to account for discrepancies in field data "result either in a statement of the obvious, viz. that a species is tending to occur in compact clumps of several individuals, or in definition of the pattern of distribution in terms of constants to which no precise biological meaning can be attached". Whilst both these criticisms may be valid when one is considering the distribution of plants (about which Greig-Smith is writing), it is not necessarily a statement of the obvious to show that animals are occurring in clumps rather than randomly distributed. It was certainly not possible in the present study to see this with the naked eye. True, the pattern of distribution has here been described in terms of constants but it is because these constants vary from one sampling date to another (unlike the situation in a plant population) that it is possible to draw conclusions of biological meaning. In this instance it has been possible to show different behaviour patterns on different hosts, and a postulated movement of nymphs after moulting. The importance of this last conclusion will be discussed in the section on nymphal mortality.

10. NYMPHAL MORTALITY ON THE SAMPLING AREAS.

a) INTRODUCTION

In view of the protective properties ascribed to their enveloping spittle, it might be supposed that the mortality rate during the nymphal stage of a cercopid would be low. Despite the economic importance of Philaenus spumarius in North America, the literature contains few systematic studies of this mortality. Wilson and Davies (1953b) made population counts of this species every ten days over a period of one month prior to the appearance of adults and recorded a 90 per cent survival rate. It seems likely, however, that this figure does not include first instar mortality.

In the present study it has been possible (because of the very low population density in 1962) to compare the mortality of N. lineatus nymphs in populations of greatly differing density. Comparisons have also been made of the same species on different vegetation types but under the same macroclimatic conditions.

b) METHODS AND RESULTS

The method of Richards and Waloff (1954) for estimating the mortality in a population in which the instars overlap, assumes that the mortality, after the population has reached its peak numbers, remains approximately steady. The logarithm of the population occurring on each day when plotted against time will thus be a straight line. Dempster (1956) has shown that in many

FIG. 26 THE PERCENTAGE SURVIVAL OF NYMPHS OF
N. LINEATUS ON THE JUNCUS AND NARDUS
SITES IN 1961 AND 1962, PLOTTED ON A
LOGARITHMIC SCALE.

FIG. 26

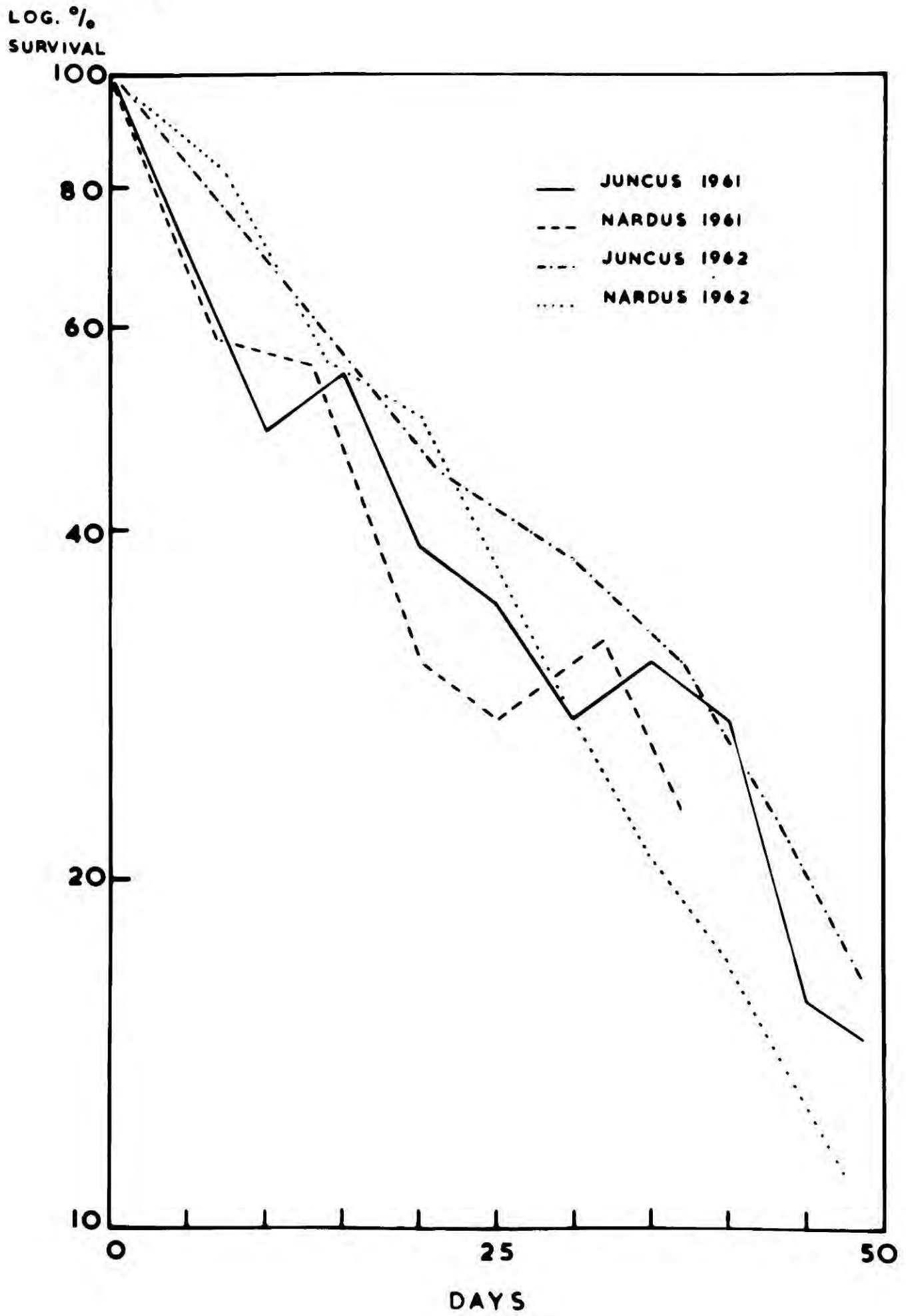

insect populations there is a differential mortality in the instars so that this relationship is not a straight line.

Logarithmic plots of each of the N. lineatus populations are shown in Fig. 26 where they have been converted so as to commence on day 0 with a peak population of 100 individuals per metre square. The mortality rates can then be compared for each site and each year. The survival rates are similar on each of the sites in both years, and the mortality appears fairly constant throughout the nymphal development period.

A criticism of this method is that although it demonstrates the mortality of the whole population, a different mortality rate in any one instar may not be very obvious. For example if instar four has a higher mortality than the population average, but instars three and five have lower mortalities, the result will be a smoothing of the logarithmic plot, which demonstrates neither the low mortality in instars three and five, nor the higher mortality in instar four. To determine whether or not differential mortality occurs, the data have been analysed in two ways :

i. Richards (1940) pointed out that the numbers of each instar found in a series of systematic samples, should correspond to the time spent in that instar; any deviation from this represents the magnitude of mortality in that stage. From the curves in Fig. 15 the numbers of each instar present on every fifth day have been estimated and are recorded in Table 37. Row A in the table gives the total numbers of each stage, and data on the duration of each

TABLE 37. JUNCUS SITE POPULATION 1961 - NUMBERS ON EVERY FIFTH DAY AND SURVIVAL ESTIMATES BY RICHARDS' METHOD.

Date	Instar	1	2	3	4	5	totals	
April	27	10					10	
May	2	30					30	
	7	50					50	
	12	75					75	
	17	116	9				125	
	22	122	18				140	
	27	80	17				97	
June	1	26	38	5			69	
	6	4	48	23			75	
	11		22	32	1		55	
	16		6	39	4		49	
	21		2	22	15		39	
	26			13	28	2	43	
July	1			2	27	10	39	
	6				7	15	22	
	11				3	17	20	
	16				1	15	16	
	21					10	10	
	26					8	8	
	31					4	4	
Row A.		513	160	136	86	81	976	Totals
B.		19	14	13	15	15	76	Instar durations (days)
C.		244	180	167	193	193		Proportions expected
D.		513	378	351	406	406		Ditto with 513 first instars
E.		.42	.89	.54	.90		.20	Survival rate/ Instar

stage (from Table 23) from row B. It is therefore possible to calculate the expected proportions of each instar if there was no mortality (rows C + D), and so the discrepancies between the numbers in rows A and D give a measure of the survival rate (row E) in each instar.

ii. A graphical alternative to this method was also used for comparison. The areas under the curves in Fig. 15 are a function of the total numbers of animals in any particular instar and the time spent in that instar. In Table 38 this data is shown together with resulting estimates of survival rates from one instar to the next.

c) DISCUSSION

The resulting estimates of survival calculated by these methods are of the percentage of nymphs surviving from the peak of one instar to the peak of the next. They have been re-expressed in Table 38A in terms of percentage survival per day, so that they may be compared from instar to instar.

1961 data. In the Juncus site population in 1961, the highest survival rate was that between instars two and three. The lowest survival rate was between instars three and four. It has been shown (sub-section 6) that in 1961, an increase in percentage of nymphs on Juncus squarrosus rather than Festuca occurred between instars three and four. Moreover, if the nymphs did not make this move, they would die. It is suggested that this is the reason for the low survival rate at this stage in the life history.

TABLE 38. ESTIMATES OF SURVIVAL RATE OF *N. LINEATUS* NYMPHS, FROM AREA OF POPULATION CURVES

	Instar	1	2	3	4	5	Total
JUNCUS SITE 1961							
Area		5125	1788	1402	900	732	
Duration (days)		19	14	13	15	15	
Numbers		270	127	108	60	49	
Survival from one instar to the next			.47	.85	.55	.82	.18
JUNCUS 1962			.53	.64	.69	.84	.20
NARDUS 1961				.59	.66	.82	.32
NARDUS 1962				.53	.66	.75	.26

TABLE 38A ESTIMATES OF SURVIVAL RATE PER DAY BETWEEN INSTARS OF *N. LINEATUS*, EXPRESSED AS PERCENTAGES

	Instar	1	2	3	4	5	Average
JUNCUS 1961		96.2	98.9	95.5	98.6		97.3
JUNCUS 1962		96.2	95.7	96.7	98.9		96.3
NARDUS 1961			96.2	96.8	99.4		97.5
NARDUS 1962			93.9	98.5	99.1		97.2

Fig. 18 shows that instar two in 1961, showed no significant aggregation. The postulated movement of nymphs, giving rise to the aggregation at the peak of instar three, would require fewer nymphs to leave their spittles than if they had been aggregated at instar two. Thus fewer nymphs might be expected to be at risk of predation or desiccation when moving, and the survival rate is correspondingly higher.

On the Nardus site, on the other hand, there is complete break down of one aggregation and formation of an independent one. This requires that more nymphs must abandon their spittle and the survival rate is lower. Similarly, the fact that nymphs do not change hosts between instars three and four is reflected in the higher survival rate of nymphs on the Nardus site than the Juncus, in both years.

It could be argued that the reason for the apparent high survival rate of instar two on the Juncus site is because instar two is not sampled as efficiently as instar three. This may be true, but it does not affect the comparisons made with the Nardus site and the conclusions drawn from these comparisons. It is unlikely that instar two is sampled more efficiently on the Nardus than on the Juncus, since spittles are much more easily seen on Juncus than on Nardus. If the behaviour of all the instars are comparable, it might be expected that there would be a steady increase in the survival rate as the nymphs became larger, more mobile and less liable to desiccation. This is found to be the

case on the Nardus site in 1961 when all the instars show the same pattern of dispersal (Fig. 20).

1962 data. It has been shown that the change of hosts on the Juncus site occurred one instar earlier in 1962, than in 1961. The change began in instar two but was not completed until instar four. Correspondingly, the survival rate per day was low between instars two and three and between instars three and four.

It has already been pointed out that the population density in 1961 was about five times that in 1962. Although the proximate cause of mortality may be the necessity to leave the spittle, the ultimate cause is probably a climatic effect such as desiccation, or predation. If the former, the risk to nymphs in a small population would not be less than to those in a larger population. If predation is the ultimate factor, however, the risk could conceivably vary with the population density. From Table 38 it is clear that the survival rate was ^{not} appreciably different in a low density population.

It has already been pointed out that both the estimate of numbers of instar one nymphs present and the estimate of their duration, may be subject to error. It was therefore thought necessary to obtain an independent estimate of the mortality between instars one and two, because both these parameters had been used to calculate the survival estimates shown in Table 38. An opportunity to do this was presented in 1963 when the population was so low that it was possible to label and follow the fate of 40 newly hatched

instar one individuals. Eleven of these died at or before moulting to instar two and a further 7 which successfully moulted did not establish themselves on the host plant and died. (In two instances the desiccated bodies were found). The survival rate was thus 0.55 (cf. an estimated .47 on the Juncus site in 1961, and .53 in 1962). It was also observed that 7 of the 22 successfully established instar two nymphs had migrated to new feeding positions on the same host species.

In Part VII, the nymphal mortality in a species of cercopid which does not have to change host plants is discussed.

Only one predator of N. lineatus has been observed. The stomach contents of 30 specimens of the common frog (Rana temporaria) were examined immediately after they had been observed to feed on the sample sites. Although the stomachs were often dilated with other invertebrates (particularly molluscs), only one specimen of N. lineatus was found (a second instar nymph).

11. NYMPHAL MORTALITY IN EXPERIMENTAL POPULATIONS

To compare the mortality of later instar nymphs when restricted to either Juncus squarrosus or Festuca, a series of experimental populations were established. Areas containing only one or other of the host plants were delimited by aluminium cylinders covering $1/10\text{m}^2$ and 35 cm high (Plate 8). Cylinders on both hosts were within a few yards of each other.

PLATE 8. CYLINDERS USED TO ESTABLISH EXPERIMENTAL
 POPULATIONS OF *N. LINEATUS* NYMPHS.

Each cylinder encloses $1/10 \text{ m}^2$ of vegetation.

PLATE 9. A *N. LINEATUS* SPITTLE ON *JUNCUS SQUARROSUS*.

This is a common site for the spittle - near the base
of the rosette. The spittle is 14 mm. long.



Four of these were set up on each host plant, and ten third instar nymphs were introduced into each, so that forty nymphs were successfully established (i.e. spittle was produced) on each host. In order to avoid any preference by the nymphs for either host, they were transferred from Nardus to the cylinders.

The populations were examined at six or seven day intervals, and the numbers surviving are recorded in Table 39.

TABLE 39. SURVIVAL OF NYMPHS OF *N. LINEATUS* IN EXPERIMENTAL POPULATIONS ON *JUNCUS* AND *FESTUCA*

Days	0	7	13	20	27	35
Number surviving on <i>Juncus</i>	40	28	24	18	16	12
Survival rate on <i>Juncus</i>	.70	.60	.45	.40	.30	
Number surviving on <i>Festuca</i>	40	19	13	4	4	3
Survival rate on <i>Festuca</i>	.48	.33	.10	.10	.08	

Thus the nymphs confined to *Juncus* show a significantly higher survival rate after 35 days ($\chi^2 = 8.21$ with one degree of freedom, $P < .01$), than those confined to *Festuca*. When this experiment was set up, the nymphs were all in instar three. A parallel experiment was therefore carried out to compare the survival rates of instars one and two confined to *Juncus* and *Festuca* respectively. Early instars of *N. lineatus* occur and feed on either *Juncus* or *Festuca*.

It is only in the later instars that the move onto Juncus only occurs. It would therefore be expected that in an experimental population where nymphs are confined to one or other of these hosts, there would be little difference in the survival rate of early instars on the two hosts.

On 3 June 1963, 31 instar one or two individuals were confined to Festuca hosts, and 27 were confined to Juncus hosts. Fourteen of the nymphs on Festuca and 12 of those on Juncus survived to moult to instar three.

There is thus no significant difference ($\chi^2 = 0.44$ with 1 degree of freedom, $P > 0.1$) between the survival rates of instars one and two on Juncus and Festuca.

C. THE ADULT

1. SEX RATIO

Instar 5 nymphs of N. lineatus can be sexed with care, using the descriptions of genitalia development by Metcalfe (1932) for P. spumarius. In all, 317 instar⁵ nymphs were sexed and the results are shown in Table 40, together with the corresponding figures for adults collected.

TABLE 40. SEX RATIOS OF NYMPHS AND ADULTS OF N. LINEATUS

	Number of males	Number of females	Total	Percentage males
Instar 5	153	164	317	48
Adults	87	91	178	49

In neither case does the ratio differ significantly from equality of the sexes.

Although not significant, there is a suggestion that males complete their development to the adult stage more rapidly than do females, so that 78 nymphs sexed from the first 12 days of occurrence of instar 5 showed a predominance of males (53% males), whilst 71 from the last 12 days showed a predominance of females (44% males).

2. MORTALITY (Fig. 27).

Since the sex ratio of instar 5 nymphs is the same as that for

FIG. 27 THE PERCENTAGE SURVIVAL OF NYMPHS AND
ADULTS OF *N. LINEATUS* ON THE JUNCUS
SITE IN 1961, PLOTTED ON A LOGARITHMIC
SCALE.

FIG. 27

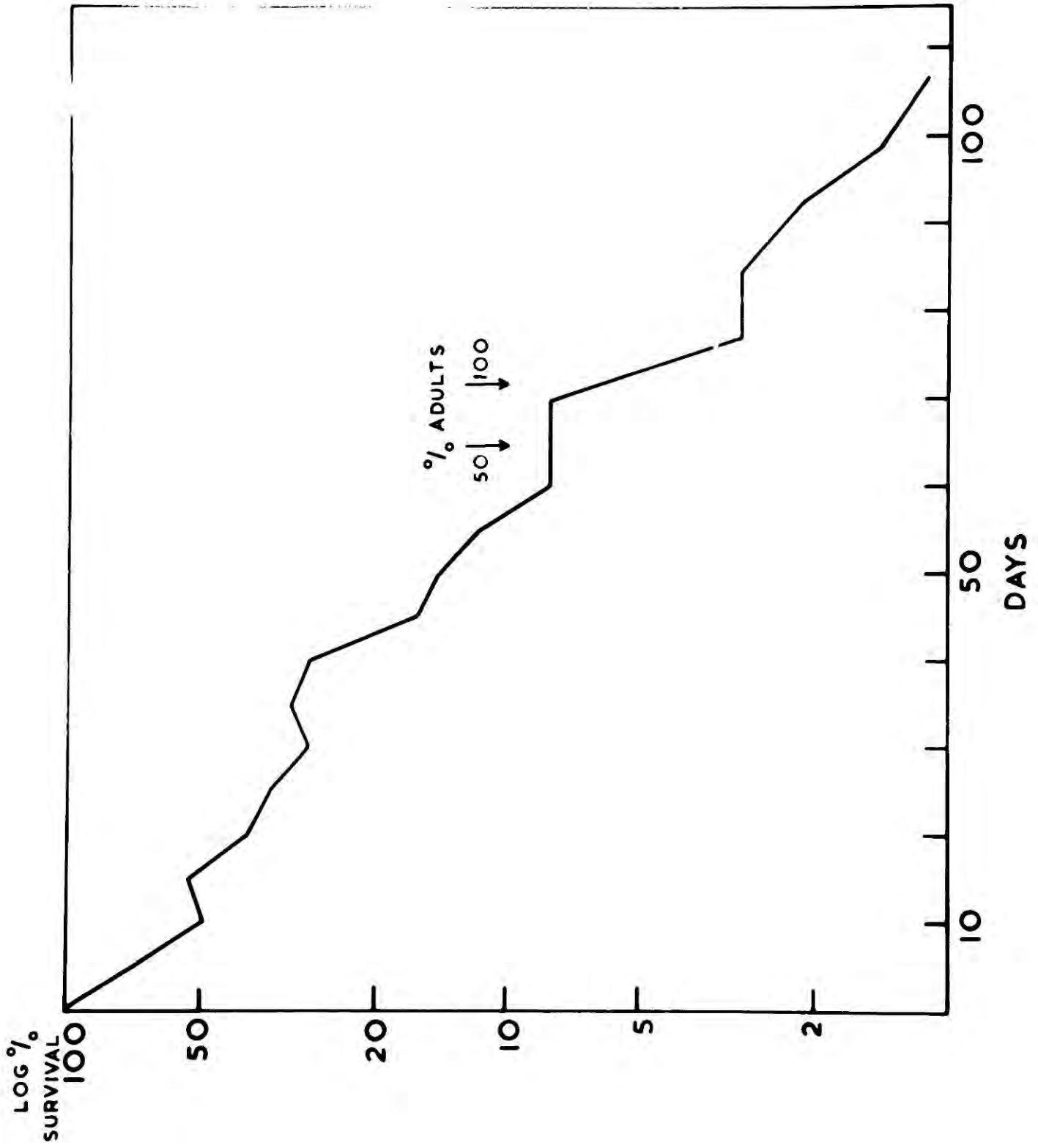

adults, it may be assumed that the mortality of adult males is not significantly different from that of females. Females do, however, tend to persist longer than males at the end of the season. Thus in October of 1961 and 1962, 12 females were taken and only 3 males. The numbers of adults per square metre sampled by the vacuum technique on the Juncus site in 1961 are recorded in Table 26. After the appearance of adults in the population the decline in numbers is not gradual, but suffers a catastrophic reduction between 3 and 7 August. This may be attributed to extremely heavy rain (2.17 inches), falling within a few hours on the night of 3 August. This was sufficient to flood parts of the sampling area, and several dead adults, which had presumably been drowned, were found on the next day. It will be shown that a large proportion of the adult mortality in N. exclamatoris also appears to be attributable to severe climatic factors. At the time of oviposition (see later) there were therefore only about two females per square metre surviving.

3. COPULATION

The earliest date at which copulation in N. lineatus has been observed at Moor House was 22 August 1962, although a mating pair was taken in the laboratory field, Durham on 6 August. These are approximately 20 and 30 days respectively after the first appearance of adults. Copulating pairs were taken until the middle of September at Moor House, and until the end of August at Durham.

In each case, the time interval between copulation being first and last observed was about 20 days.

During copulation, the male lies slightly obliquely across the dorsal surface of the female and remains in this position by hooking the claws of the prothoracic limb over the edge of the costa of the female's elytra, which is slotted just above the origin of the vein. After mounting, the female may carry the passive male about in this position but both become passive after about 10 minutes and rhythmical movements of the genitalia proceed for up to two hours before separation.

4. OVARY DEVELOPMENT

Boring (1913), in her study of the chromosomes of Philaenus spumarius, showed that oogenesis is a delayed process, whilst Robertson and Gibbs (1937) showed that the mechanism of spermatogenesis and release of the sperms in the spermatheca of the female is designed so that delayed fertilisation can take place. Well developed eggs are therefore not found in the females of this species until about half way through the adult life (Weaver 1959). If this is also the case in N. lineatus, problems are raised as to how the adult females are able to mature eggs and oviposit, since their period of life is considerably curtailed at high altitudes. Dissections were accordingly made in order to study the ovary condition of N. lineatus, from instar 5 onwards. Measurements were made of the maximum length of the developing ova. It is possible to find very rudimentary ovaries

with visible ova in instar 4, and in instar 5 the ova have reached a mean length of 0.21 mm (14) - (the figures in brackets indicate the number of individuals dissected). Such females had between 7 and 10 developing ova in each ovary, there being one developing ovum in each ovariole. This agrees with the observations of Holmgren (1899).

Adult females dissected during the two weeks after the first appearance of adults had a mean of 16 developing ova in the two ovaries, with a mean length of 0.28 mm (12). Three to four weeks after the first emergence of adults (i.e. when copulation was first recorded) the mean ova length was 1.12 mm (19). Fully developed ova (i.e. the maximum length reached in the body cavity of the adult) measured 1.21 mm (10) and this increased to 1.25 (4 ova measured) when deposited. At copulation therefore, the ova were almost fully developed, and the maximum length was reached in females dissected during the time when copulating pairs were taken. Females taken in copulation have also been dissected and fully developed ova were found in the body cavity. Ova are therefore probably fully developed at copulation in N. lineatus. In females dissected at the time when the ova in the body cavity were mature, there was no indication that a second batch of eggs was developing, and the ovaries appeared degenerate. This agrees with the statement by Holmgren (1899) that each ovariole in N. lineatus produces only one egg. It would be possible to determine whether more than one batch of eggs can be produced, by culturing specimens. This has been attempted without success, similar difficulty having been experienced by other workers (e.g. Halkka 1962).

5. OVIPOSITION

Oviposition was actually observed in the field at the beginning of September in 1961 and 1962 (i.e. during the time when copulating pairs were taken), and a female mated on 4 September 1962 and then caged on Juncus squarrosus and Festuca had oviposited (on Festuca) seven days later. Oviposition was not actually observed in this case and the seven days is a maximum period. Thus, the egg laying takes place about 4 weeks after the emergence of the adult. There are thus only a few days between fertilisation and oviposition in N. lineatus. It is suggested that this may be a significant factor in the ability of the species to complete its life cycle over a wide altitudinal range in the Pennines.

6. THE EGG

It has only been possible to find eggs of N. lineatus in the field by caging fertilised, gravid females on a small area and carefully searching the vegetation after oviposition has taken place. They were found to be deposited in groups of up to four eggs cemented into the axils of Festuca by a hard, white substance. The eggs are of a cream colour when laid, turning light brown with age.

7. HATCHING

Weaver and King (1954) are of the opinion that overwintering diapause in eggs of P. spumarius is broken by exposure to low temperatures. Development then proceeds when certain conditions of temperature and humidity are fulfilled. Thus, eggs of this species

only show high hatching success if exposed to humidities of 90 per cent or more and 10°C , after a period of cold stimulation. Imms (1929) gives a similar humidity figure for the sugar cane frog-hopper (Tomaspis saccharina). It has been observed that hatches of N. lineatus and P. spumarius occur at the same time in the same habitats. Hatching conditions are therefore comparable in the two species. Because of the impossibility of collecting large numbers of eggs for experimental purposes, hatching data in the present study is restricted to information on field conditions at the time of hatching.

Eggs of N. lineatus may be induced to hatch as early as March by bringing cut turf containing eggs into the laboratory, and maintaining it at high humidity and temperature. The optimum temperature conditions for hatching in the field were investigated as follows:

It is assumed that there is a threshold temperature at which development starts, and that the cumulative effect of temperatures above this threshold will induce hatching when the eggs have been exposed for a certain number of degree-days. These conditions should be the same in each of the three years studied.

Arbitrary threshold screen temperatures were selected (from $40-48^{\circ}\text{F}$; $4.4-9.0^{\circ}\text{C}$. in one degree Fahrenheit intervals) and the number of degree-days on which these thresholds were exceeded in the field prior to the hatch were calculated for each of the years. Table 41 shows that the threshold of 45°F (7.2°C) gives approximately the same number of degree-days in excess of this threshold in each

year. (The figures in the table are based on degrees Fahrenheit because the original meteorological data was expressed in this way). The eggs can only be considered to have been exposed to the same temperature conditions if account is taken of this threshold. None of the other threshold values selected would cause the eggs to be exposed to the same pre-hatching conditions in each of the three years. About 7.0°C is therefore taken to be the most reasonable approximation to the threshold temperature for development.

TABLE 41. DEGREE-DAYS FROM A SERIES OF ARBITRARY HATCHING TEMPERATURES

Threshold screen	$^{\circ}\text{C}$	4.4	5.0	5.6	6.1	6.7	7.2	7.8	8.3	8.9
temperatures	$^{\circ}\text{F}$	40.0	41.0	42.0	43.0	44.0	45.0	46.0	47.0	48.0
Degree	1961	941	821	739	697	568	<u>328</u>	238	192	145
days	1962	974	934	729	645	473	<u>341</u>	341	203	109
	1963	1,125	1,045	799	547	418	<u>330</u>	240	148	148

8. EGG MORTALITY

Elsewhere in this section it has been shown that there were only two adult females per square metre at the time of oviposition in 1961, and that these could only have produced a maximum of 16 eggs each. Therefore there could not have been more than 32 eggs deposited per square metre and overwintering on the Juncus site. Recruitment of

instar one individuals to the 1962 Juncus site population was approximately 20 nymphs per square metre. Therefore egg mortality was a maximum of 35 per cent.

D. THE EFFECT OF ALTITUDE ON N. LINEATUS

1. INTRODUCTION

Most of the present work has been concerned with a species of cercopid occurring at a particular part of its altitudinal range (viz. at about 1,800 feet). N. lineatus is not strictly a montane species, however, and so it has been possible to compare the Moor House studies with data collected over a considerable part of the animal's altitudinal range. Particularly in the case of a phytophagous insect, the distribution of host plants is obviously an important factor in determining its range. The insects chosen in the present study were therefore selected because one of the important host plants, Juncus squarrosus was dominant or very common over the whole altitudinal range. N. lineatus feeds on the leaves and stems of its host plants. Pearsall (1950) showed that although altitude affects seed production and flowering of Juncus squarrosus, the vegetative growth is little affected. It therefore seems reasonable to assume that the altitudinal zonation of N. lineatus will not be affected directly by the distribution or condition of Juncus squarrosus on the transects studied. Pearsall (loc. cit.) is of the opinion that temperature largely controls altitudinal zonation, and he cites examples of upland organisms in which the rate of development is retarded at higher altitudes.

Sampling was carried out briefly in 1961, and in more detail in 1962 to compare the percentage instar composition (and hence the age

composition of the population) at different altitudes. The two transects studied have been described in section II.

Juncus squarrosus is only commonly found down to the upper limit of cultivation. The comparative samples taken at the lower end of the range (in the laboratory grounds, Durham) were therefore from a different vegetation type.

2. DORTH GILL TRANSECT 1961

On 16 June, 1961, nymphs of N. Lineatus were sampled at six stations on a transect rising from 1,500 to 2,000 feet (The transect is described in section II). Samples were taken at approximately one hundred foot intervals by throwing quadrats to estimate the density and percentage instar composition at each station. The vegetation was predominantly Juncus squarrosus over the whole transect. Twenty quadrats ($1/5 \text{ m}^2$) were thrown at each of the stations and the results are presented in Table 42. In this table, instars two and three are grouped because they could not be separated when the count was made.

TABLE 42. NUMBERS AND COMPOSITION OF THE DORTH GILL SAMPLES, 16 JUNE 1961

Station (altitude in feet)	Number per metre square	Percentage Instars			
		1	2 & 3	4	5
1,500	4 \pm 0.95	0	73	27	0
1,600	13 \pm 2.1	0	87	13	0
1,700	26 \pm 4.0	0	84	16	0
1,800	23 \pm 3.7	0	93	7	0
1,900	7 \pm 1.1	0	89	11	0
2,000	2 \pm 0.75	25	75	0	0

This data suggests that as altitude increases, the percentage of early instars on any date increases.

Samples were also taken in 1961 at a number of altitudes above 1,800 feet, the highest being at 2,700 feet on the south-west slopes of Cross Fell. This was the highest point at which N. lineatus has been taken. Table 43 shows the results of these samples.

TABLE 43. DATES OF OCCURRENCE OF CERTAIN INSTAR COMPOSITIONS OF POPULATIONS AT DIFFERENT ALTITUDES

	Date (1961)	Altitude (Feet)
100 per cent instar five.	20 July	1,800
	18 July	1,850
	22 August	2,400
	10 September	2,700
20 per cent instar four, 80 per cent instar five.	11 July	1,850
	31 August	2,700

Adults were absent in the cases shown. Similar instar compositions are seen to occur on progressively later dates as altitude increases. Thus whilst adults appeared in the population at 1,800 feet on 21 July 1961, they had not appeared at 2,700 feet on 13 August, and only one was taken after repeated sweeping on 10 September. On the Dorth Gill transect, adults were present in considerable numbers at

the lower stations (1,500 - 1,600 feet altitude) on 20 July 1961. How far these facts are due to differences in the hatching dates, and how far they are due to retardation of development after hatching, cannot be ascertained from the 1961 data.

If a series of collections are made at different dates during the nymphal part of the life history, and a comparison made of the instar composition of the population at each altitudinal station and on each date, delays due to retardation of development at high altitudes can be distinguished from delays due to differences in hatching dates. Thus if a comparison of two stations on a date near the beginning of the nymphal season shows a difference in instar composition corresponding to x days, and a comparison of the same two stations at a later date shows a difference of $x + y$ days, it is likely that both factors are responsible for the delayed development at higher altitudes. If the difference remains constant, however, it is the hatching date along which is affected by altitude. The data in Table 44 (discussed later) fits the former case. Both factors are the result of lower temperatures at higher altitudes (Table 4).

3. MIDDLE TONGUE TRANSECT 1962

In view of the rather small altitudinal range of the Dorth Gill transect, it was decided in 1962 to sample seven stations at approximately 250 feet intervals up a transect extending from 1,250 to 2,750 feet, on a part of the west side of the reserve known as Middle Tongue (See section II).

Fifty spittles were collected at random at each of the stations and taken to the laboratory for instar identification. The percentages of instars found at each station are recorded in Table 44.

TABLE 44. INSTAR COMPOSITION OF *N. LINEATUS* ON THE MIDDLE TONGUE TRANSECT, 1962.

50 individuals collected at each station on each date.

Date	Station	Altitude (Feet)	Percentage Instars					Callow adults
			1	2	3	4	5	
27 June	1	1,250	0	0	24	76	0	0
	2	1,500	0	8	43	49	0	0
	3	1,750	0	11	81	8	0	0
	4	2,000	0	32	68	0	0	0
	5	2,250	38	24	38	0	0	0
10 July	1	1,250	0	0	2	51	47	0
	2	1,500	0	0	0	73	27	0
	3	1,750	0	2	4	81	13	0
	4	2,000	0	1	58	41	0	0
	5	2,250	0	25	60	15	0	0
26 July	1	1,250	0	0	0	6	88	6
	2	1,500	0	0	0	0	98	2
	3	1,750	0	0	0	17	83	0
	4	2,000	0	0	0	54	46	0
	5	2,250	0	0	5	60	35	0

It is clear that later instars are found much earlier at the lower end of the transect than at the upper part.

In order to separate the effect of differences in hatching date and retardation of development, the ~~data~~ information in this table has been used to calculate the figures in Table 45. In addition to the detailed Moor House sampling at 1,800 feet and the Middle Tongue transect data, a population of N. lineatus at 70 feet O.D. was studied in Durham. In Table 45, the number of days difference between the dates at which each of the populations studied had the same instar composition (and was thus at approximately the same stage in development), are compared. Taking the Middle Tongue sample as a standard in each case, the Durham and Moor House populations are compared with this by indicating an earlier date with a negative sign and a later date with a positive sign. In the final column of the table, the difference between the Durham and Moor House populations is shown (calculated from the previous two columns of the table). This acts as a check on the accuracy of the delay estimates because if the estimates are reasonable, then the final column should show approximately the same delay for the same date, even though the figure is arrived at from different sources. This is seen to be the case.

Two conclusions may be drawn from this table : The number of days difference increases as altitude increases (the conclusion already drawn from the Dorth Gill data) and the differences also increase as the season progresses. Thus although there were only nine days difference between Station 1 Middle Tongue and Durham on 27 June, this had increased to 17 days by 10 July and 22 days by 26 July.

TABLE 45. COMPARISON OF DURHAM AND MOOR HOUSE POPULATIONS OF
N. LINEATUS WITH THE MIDDLE TONGUE TRANSECT 1962.

Middle Tongue Stations	Date	Durham - days difference from Middle Tongue	Moor House - days difference from Middle Tongue	Calculated difference between Moor House & Durham (days)
1	27 June	- 9	+ 9	18
	10 July	- 17	+ 7	24
	26 July	- 2 2 ⁵	+ 6	31
2	27 June	- 14	+ 5	19
	10 July	- 19	+ 3	22
	26 July	- 24	+ 6	30
3	27 June	- 19	- 1	18
	10 July	- 22	0	22
	26 July	- 28	- 2	30
4	27 June	- 21	- 4	17
	10 July	- 30	- 10	20
	26 July	- 38	- 10	28
5	27 June	- 24	- 7	17
	10 July	- 33	- 12	21
	26 July	- 40	- 12	28

The altitudes of the Middle Tongue stations are recorded in Table 44.

It may therefore be concluded that as altitude increases :

1. The hatch of N. lineatus is progressively delayed.
2. Development is progressively retarded.

Both these points are illustrated by the week by week comparison of the Durham and Moor House populations in 1962 (Table 46). The sampling dates do not correspond exactly and so the number of days from May 12 are listed in both cases for ease of comparison.

TABLE 46. COMPARISON OF DURHAM AND MOOR HOUSE POPULATIONS OF *N. LINEATUS*, 1962.

LABORATORY FIELD, DURHAM					JUNCUS SITE, MOOR HOUSE						
Date	Days from 12 May	Percentage Instars	Instars	Date	Days from 12 May	Percentage Instars	Instars	Date	Days from 12 May	Percentage Instars	Instars
May 12	0	100									
14	2	93	7								
22	10	63	37								
28	16	20	78	2	17	100					
June 2	20	2	57	38	19	96	4				
8	26		19	65	25	64	36				
16	34		3	37	31	20	72	8			
23	41			26	38		49	49	2		
July 2	51		3	97	52	40	60				
					61	8	64	28			
					68		47	53			
					74		25	75			
					82			100			

Adults appeared between 2 and 7 July

Adults appeared between 1 and 4 August

VII. THE BIOLOGY OF NEOPHILAENUS EXCLAMATIONIS

1. INTRODUCTION

Apart from taxonomic descriptions and some habitat references, no literature on N. exclamationis has been found. The species is a common one on limestone grassland areas at Moor House and is described by Edwards (1896) as being locally abundant on low plants in dry places. Adults are easily distinguished from N. lineatus by their smaller size and the presence of a white "!" mark along the costa of the elytra. The amount of spittle produced by nymphs of this species is less than is produced by N. lineatus, but the nymphs themselves are not easily distinguished. Because of these factors, the presence of N. exclamationis at Moor House was not suspected until adults were taken by sweeping on 2 August 1961. Data on the nymphs of this species are thus restricted to the 1962 season when a grid was set up on the Festuca/Agrostis grassland and a similar study made to that on N. lineatus. The object of the study was to provide information on the life cycle of the species for comparison with N. lineatus, and to investigate the nature of its distribution on the host plants and the related mortality of the nymphs. The techniques used for the study of N. lineatus were therefore applied, and comparable data on the duration and number has been collected, together with estimates of the survival rate in each instar. Spittles of this species are only found by carefully teasing apart the vegetation, because the

nymphs feed at the base of the Festuca plants and only produce small quantities of spittle.

2. THE DISTRIBUTION OF NEOPHILAENUS LINEATUS AND N. EXCLAMATIONIS

The life histories of N. lineatus and N. exclamationis are contemporaneous with each other and similar in many respects. It may therefore be expected that they will be in competition.

N. lineatus nymphs were not found on the limestone grassland sampling grid and N. exclamationis nymphs were not found on the Juncus or Nardus grids. On the banks of Rough Sike (see Plate 7), mineral soil is overlaid by a layer of peat slipping down from the mixed moor above and an extremely abrupt change from a limestone grassland vegetation to moor edge Juncus squarrosus is present. On 5 and 6 July 1962 cercopid nymphs were collected from 15 cm on either side of this junction to see if there was any overlap of habitat and possible competition between the two species during the nymphal stages. A total of 15 nymphs in instars 3, 4 and 5 were collected on the Festuca/Agrostis side of the junction. The specimens included 13 N. exclamationis which were found on Festuca, and one N. lineatus found on a Carex. The other specimen could not be identified with certainty because the measurement of head width (used to separate the species) was in the area of overlap between the two species (Tables 19 and 47). Twelve nymphs in instars 3, 4 and 5 collected on the Juncus side of the boundary were found to be 10 N. lineatus and 2 N. exclamationis. The latter were found on the

Festuca between the Juncus rosettes. Thus, even along a vegetational boundary 30 cms wide, there is little overlap of the two species and no evidence of competition between them now, although their different distributions may be a result of competition in the past.

In spite of the difficulty of separating the nymphs of the two species without detailed measurements, it may be reasonably assumed that specimens collected on Juncus or Nardus will be N. lineatus and those collected on Festuca/Agrostis will be N. exclamationis. Both species can pass part of their life history on Festuca, but the relatively sessile nature of N. lineatus nymphs and their need in the later instars to feed on Juncus squarrosus means that they cannot occur on the limestone grassland in the early instars and then move on to Juncus in the later ones. The tendency of adult N. exclamationis to occur on the dryer hummocks rather than the more humid hollows of the limestone grassland (see later) suggests that they are not likely to stray on to the more ^{humid} Juncus areas (section V), to oviposit on the Festuca between the Juncus rosettes. This could ensure that the nymphs of N. exclamationis do not compete with early instars of N. lineatus on this Festuca.

3. THE NYMPHS

a) DETERMINATION OF INSTARS

Following the method described for N. lineatus, head capsule widths of the N. exclamationis nymphs were measured and the results, which fell into five size groupings, are expressed in Table 47.

TABLE 47. HEAD WIDTHS OF NEOPHILAENUS EXCLAMATIONIS.

	Instar	1	2	3	4	5
Observed mean head width (μ) and S.D.		420 ± 18	560 ± 16	730 ± 30	970 ± 79	1250 ± 60
Rate of increase		1.32	1.30	1.33	1.29	(Mean 1.31)

If these figures are compared with those for N. lineatus in Table 19, it is seen that the N. exclamationis nymphs are consistently smaller. There is, however, a slight overlap of large N. exclamationis and small N. lineatus nymphs in each instar. Thus head width measurements are not an absolutely reliable method of identifying nymphs of the two species. Moreover, there do not appear to be any morphological differences apparent before the adult stage, except that nymphs of N. exclamationis, whilst showing the same markings as N. lineatus nymphs, are generally paler in colour.

b) DURATION OF INSTARS IN THE FIELD

The durations of the instars in the field in 1962 were estimated and are compared with the estimates for N. lineatus in 1962 (Table 48).

TABLE 48. DURATION OF INSTARS OF N. LINEATUS AND N. EXCLAMATIONIS 1962

	INSTAR	1	2	3	4	5	Total
N. lineatus		16	10	12	15	15	68 days
N. exclamationis		17	9	11	13	11	61 days

Under similar macro-climatic conditions, N. exclamationis completes development to the adult more quickly than does N. lineatus.

c) DISTRIBUTION OF THE NYMPHS

N. exclamationis occurs exclusively on Festuca on the limestone grassland site, over which there is an almost continuous cover of this grass. Also, the Festuca is a small plant, so that even if the nymphs change feeding positions on the host in each instar, it would involve very little movement. The coefficient of dispersion of the nymphs has been calculated from instar two onwards (data during the first instar are not comparable because the sample size was changed). In contrast to the situation of N. lineatus on the Nardus and Juncus sites, the coefficient does not show fluctuations corresponding to the peaks of occurrence of the instars (Table 49).

TABLE 49. THE COEFFICIENT OF DISPERSION OF NYMPHS OF N. EXCLAMATIONIS ON EACH SAMPLING DATE FROM INSTAR TWO ONWARDS, IN 1962.

Date	Variance	Mean	V/M
June 14	2.32	1.23	<u>1.88</u>
20	3.14	1.63	<u>1.93</u>
28	2.16	1.30	<u>1.66</u>
July 5	1.44	0.97	<u>1.48</u>
12	1.00	0.68	<u>1.47</u>
20	0.72	0.56	1.29
27	0.30	0.28	1.07

Coefficients of dispersion showing significant aggregations are underlined.

The changes in V/M ratio can be accounted for on the basis of mortality (if the coefficient of dispersion varies with the mean - Clapham 1936), or by random movement away from an initial aggregation. Exuviae of earlier instars were commonly found in spittles (e.g. exuviae were found in the spittles of 48 per cent of the 58 second instars collected, and many must have been missed because of their very delicate nature). It seems likely therefore, that there is little random movement, and that the changes in V/M are a result of mortality. They are not comparable with the fluctuations shown to occur in the coefficient of dispersion of N. lineatus nymphs. Also in contrast to N. lineatus on the Juncus site, nymphs of N. exclamationis have not been found to aggregate within spittles. These two factors have been suggested as causes of mortality in N. lineatus. The survival of N. exclamationis nymphs has therefore been studied, because if some of the mortality of N. lineatus nymphs is a result of the need to leave the protective spittle, it may be expected that the survival rate in a species which can complete its life cycle on the same host plant will be higher.

d) MORTALITY OF THE NYMPHS

Estimates of the survival rates of the instars of N. exclamationis have been calculated according to the method employed for N. lineatus nymphs, and are listed in Table 50. There is little difference in the survival rate in each instar and they are higher than those recorded for N. lineatus during those instarsⁱⁿ which nymphs leave the spittle and search for new feeding sites (Tables 38 and 38A).

TABLE 50. SURVIVAL RATES OF NYMPHS OF *N. EXCLAMATIONIS*, 1962
DETERMINED FROM AREA OF POPULATION CURVES

INSTAR	1	2	3	4	5	Total
Area (arbitrary numbers)	5150	1417	1408	1300	834	
Duration (days)	17	9	11	13	11	
Numbers	302	157	128	100	76	
Survival from one instar to next	.52	.81	.78	.76		.25
Survival per day	.975	.976	.977	.979		.977 (average)

3. THE ADULT

a) DISTRIBUTION

It has been pointed out that the limestone grassland at Moor House is partly made up of a series of hummocks and hollows (Section II). The former are much better drained than the latter and support a denser vegetational cover, which differs somewhat in species content from the hollows. Both hummocks and hollows, however, support Festuca and Agrostis grassland, but the denser cover on the hummocks gives rise to a different environment than in the hollows, by affecting the micro-climate (Section II). Thus a relatively small area of grassland which is all on limestone has two quite different micro-habitats. With this in mind, adults of *N. exclamationis* were sampled by sweep netting on the hummocks and hollows. The data are summarized in Table 51.

TABLE 51. DENSITIES OF *N. EXCLAMATIONIS* ON THE HUMMOCKS AND HOLLOWES OF THE LIMESTONE GRASSLAND IN 1961

Date		Number of <i>N. exclamationis</i> per 50 sweeps			In hollows		
		Males	Females	Total	Males	Females	Total
Aug.	6 a)	55	44	99	9	9	18
	b)	50	56	106	10	9	19
	17	22	24	46	11	13	24
	23	14	28	42	10	12	22
Sept.	1	24	16	40	6	8	14
	6	16	22	38	1	4	5
	12	12	4	16	4	8	12
	29	5	7	12	1	2	3
Oct.	16	7	8	15	0	4	4
	23	5	10	15	1	1	2
Totals		210	219	429	53	70	123

Care was taken to standardise the sweeping as much as possible, but even so the error discussed in Section IV must apply here. Even if allowance is made for this error, on every date during the season the density of adult *N. exclamationis* on the hummocks exceeded that in the hollows. The denser vegetation of the hummocks (although the grass species present are the same) may account for this, but the drier nature of the hummocks may also be important, because *N. exclamationis* is described by Kontkanen (1950) as "a species of

the drier biotopes" and by Ossianilsson (1946-47) as common on dry grassland.

It is not possible to estimate the absolute density of a population with the sweep-net method of sampling, and so an estimate of the numbers of N. exclamatoris present was made with the vacuum sampling technique. The latter method is too laborious to use for all the sampling. On 17 August 1961, the densities of N. exclamatoris on the hummocks and hollows were 47 ± 9 and 12 ± 4 per metre square respectively.

b) MORTALITY

In spite of criticisms of the sweep net method of sampling, some indication of the mortality of N. exclamatoris adults can be obtained from the data recorded in Table 51. This is possible because the samples were taken on the same vegetation using a standard procedure, and involve only one species. The main variable is the weather, but as far as possible the samples were taken under similar conditions of insolation and with the vegetation dry. The hummock data only is used, because the numbers in the hollows were small.

The numbers of adult N. exclamatoris taken in the net did not steadily decline through the adult season. Between 6 and 17 August, and 6 and 12 September, there are two marked drops in the population which together account for 80 per cent of the adult mortality. In August 1961, the minimum screen temperature at Moor House went below

freezing on only one date (the 12th). Table 51 shows that a catastrophic fall in numbers of adult N. exclamatoris occurred between 6 and 17 August. The grass minimum temperature on this occasion (the 12th) was -4.2°C - the lowest recorded in August. Similarly, the fall in numbers between 6 and 12 September, corresponded with the lowest grass minimum recorded in that month; -3.2°C . on 8 September. Although these correspondences are not sufficient to show a correlation, there seems no other reasonable explanation for such heavy adult mortality in a restricted period of time, other than severe climatic effects.

The importance of these catastrophes depends on whether or not they occur before oviposition has begun. Oviposition was, in fact, first observed in 1961 on 1 September, and dissection of females showed that eggs are fully developed about three weeks after emergence (which occurs about the first week in August). Copulation was first observed on 17 August in 1961.

The largest fall in numbers occurred before any females could have oviposited (i.e. only one to two weeks after adults were first observed), and the second period of high mortality also occurred before many females would have oviposited. Since the time of these high mortalities appears to be entirely fortuitous, it follows that the number of eggs successfully laid to contribute to the next year's population is also fortuitous. Female N. exclamatoris do not mature more than one egg in each of 20 ovarioles, so that each ovipositing female can only contribute a maximum of 20 eggs.

Whether or not such catastrophies occur before or after oviposition will greatly influence the maximum size of the following year's population.

It is possible to make a comparison of the size of the adult population of N. exclamationis on the limestone grassland in 1961 and 1962, even though no estimate of nymphal density was made in 1961. If a comparison is made of the peak number of adults taken in the sweep net in the two years, the 1961 population had a peak of 106 adults per 50 sweeps, and the peak in 1962 was 32 per 50 sweeps. This represents a decrease of 70 per cent. The previously noted fall in numbers of N. lineatus is also found in N. exclamationis.

VIII. STUDIES ON PHILAENUS SPUMARIUS

1. INTRODUCTION

The common cercopid in Europe and eastern North America is Philaenus spumarius, which commonly attacks meadow plants and garden species of herbs, although it will survive on nearly any succulent foliage. The correct name of this species has been in some doubt, and it has often been called P. leucophthalmus in the literature. The position has, however, been discussed in section III, and the name spumarius adopted here.

It has already been mentioned that P. spumarius occurs in only very small numbers on the Reserve. Because of the usual absence of cultivated land over about 1,500 feet in England, this species is rarely met with at higher altitudes, where it is replaced by members of the genus Neophilaenus. Its occurrence at approximately 1,850 feet at Moor House is therefore exceptional, and attributable to the existence of a cultivated area of grassland in the form of a paddock on the west side of the house. Although this area supports many possible hosts, the species is restricted to a narrow belt of sheltered vegetation a yard or two wide along the wall of the area. This paddock has been manured for several decades and the hay crop used as forage for horses. It contains many lowland species of grasses and herbs which may have been brought to Moor House as additional forage and become established. It seems likely that P. spumarius was introduced in this way because the Moor House population is isolated from other

populations by some miles of wind-swept moor and by 400 feet of altitude. Although P. spumarius is not a moorland species, its presence at this altitude is not without interest, especially since it provides an example of an isolated population. This is important because the species displays several colour varieties, which appear to occur in relatively fixed proportions in populations studied in other countries. No data exists for the proportions of these varieties in Britain and work on the species at Moor House has been confined to this problem, and the comparison of the population with others in the north of England.

2. HOST PLANTS AT MOOR HOUSE

P. spumarius nymphs have been observed to feed on the following hosts in the paddock :

Rumex acetosa	Ranunculus repens
Plantago lanceolata	Geum rivale
Caltha palustris	Stellaria graminea
Alchemilla glabra	Primula veris
Conopodium majus	Veronica chamaedrys
Achillea millefolium	Anthriscus sylvestris
Urtica dioica	

Although this list is extensive, the total number of P. spumarius in the paddock was very small. In spite of the fact that suitable hosts were present throughout the 2 acre area, the species was

restricted to a narrow band running beside the 5 feet high wall at the lower edge of the paddock. There are two possible reasons for this :

i. Each year in July and August the paddock is cut and harvested, leaving only a narrow band of upstanding vegetation along the wall. Even before this harvesting, however, there were no spittles at a greater distance than some three or four yards from the wall, in spite of the fact that adults of P. spumarius are capable of considerable migratory movement (e.g. Evans and Lanham 1960). Moreover, no adults were taken in the centre of the area, even though they were fairly abundant at the fringe (e.g. 23 per 100 sweeps). The stubble area left in the centre of the paddock would provide ovipositing sites, yet is not utilised.

ii. It would therefore seem that P. spumarius is only able to survive at high altitudes where suitable hosts are present and where shelter is available. In contrast, the two species of Neophilaenus present at Moor House require little shelter and less succulent hosts.

3. COLOUR VARIETIES

Collections of adult P. spumarius from the paddock area were made with a sweep net in the summers of 1961 and 1962. Since it was intended to compare the frequencies of the colour varieties with those in non-isolated lowland populations, it was found necessary to make collections in certain lowland localities, because no data exists

on the occurrence of the varieties in Britain. Populations sampled were in the laboratory field, Durham, on the west coast at Ainsdale, Lancashire, and on the east coast at Holy Island, Northumberland. The relative proportions of the varieties are shown in Table 52. Because of the small numbers involved, those varieties other than populi, typica and trilineata have been grouped and are listed in the Table as "others". The proportions of the Moor House varieties have been compared with those from elsewhere by computation of χ^2 values.

TABLE 52. PROPORTIONS OF COLOUR VARIETIES OF *P. SPUMARIUS* IN A GENERAL COLLECTION AND AT MOOR HOUSE.

Variety	populi	typica	trilineata	"others"	Total
General collection	86 (24)	149 (41)	103 (28)	27 (7)	365
Moor House	25 (32)	40 (51)	4 (5)	9 (12)	78
χ^2	2.94	3.30	17.5	2.08	
P	> 0.05	> 0.05	< 0.001	> 0.05	

Figures in brackets are percentages of the total. The χ^2 test compares the proportions in the general collection and at Moor House.

The Moor House population has a significantly lower proportion of the variety trilineata than was present in the general collection, but other varieties did not differ significantly. The relative proportions of the varieties do not differ significantly in 1961 and 1962 at Moor House (χ^2 never greater than 2.72 with one degree of freedom). An interesting feature of the Moor House collection was the capture of a male specimen of the variety lateralis. Halkka (1962) had 201 specimens of this variety; all females, and he lays stress on the statement that males of this variety do not occur.

Although no previous records of the proportions of colour varieties have been made in Britain, Halkka (loc.cit.) has published data from Finland. The present writer has also sampled a population at Tvarminne in south west Finland, in 1963, and the data is recorded in Table 53 where it is compared with Halkka's findings. Comparison of the present writer's specimens with those of Halkka has shown that they have been demarcated in the same way. The data from Finland has been grouped for comparison with Table 52.

TABLE 53. PROPORTIONS OF COLOUR VARIETIES OF P. SPUMARIUS IN FINLAND

Figures in brackets are percentages of the total.

Variety	populi	typica	trilineata	"others"	Total
Halkka	88 (0.9)	8,806 (85.5)	442 (4.3)	968 (9.3)	10,304
Whittaker	39 (2.2)	1,567 (87.4)	21 (1.2)	165 (9.2)	1,792

The proportion of trilineata at Moor House compares with that in Finland, but it is much more abundant in lowland samples from Britain. The variety populi is commoner in both the general collection and at Moor House, than it is in Finland.

The biological significance of these observations cannot be ascertained without further investigation.

IX. POPULATION STUDIES ON OTHER AUCHENORRHYNCHA

1. INTRODUCTION

Cercopidae are unique amongst the Auchenorrhyncha in that for a considerable part of their life history they are surrounded by a protective envelope of spittle. The other Auchenorrhyncha at Moor House have no such protection, although they do have the advantage of mobility, even in the nymphal stages. Thus even early instars of cicadellids and delphacids can move about actively on their host plants. Very few of the species of Auchenorrhyncha at Moor House occur in large enough numbers for quantitative sampling to be practicable. There is one species of cicadellid which occurs together with a delphacid on the Juncus site in sufficient numbers for both to be quantitatively sampled. This site was also being sampled with the vacuum extractor to determine the number of adult N. lineatus present and it was therefore possible to sample Macrosteles sexnotatus (Cicadellidae), and Conomelus anceps (Delphacidae) at the same time, during the 1961 and 1962 seasons. Both species hatched at the beginning of June (after overwintering as eggs), and persisted as adults until into October. The aim of the sampling was to determine whether species of Auchenorrhyncha which do not have a protective spittle for the nymphs, have a higher nymphal mortality than those which do, and to compare population densities and mortality rates in the two years.

2. THE POPULATION DENSITY OF MACROSTELES SEXNOTATUS.

Nymphs of this species are easily distinguished from those of other Cicadellidae found on the Juncus site, by the presence of distinctive head markings reminiscent of those of the adult. The apex of the crown has a dark triangular area separated from the rest of the crown by a white line. The fuscous disc of the crown has a darker rounded mark on either side of the mid line, which latter is white and continues forwards to bisect the dark triangular area. Table 54. lists the mean head widths of each of the five nymphal instars.

TABLE 54. HEAD WIDTHS OF MACROSTELES SEXNOTATUS NYMPHS

Instar	1	2	3	4	5
Mean head width (μ)	38	47	59	72	89
and S.D.	\pm	\pm	\pm	\pm	\pm
	1.9	1.4	2.3	3.6	4.9
Rate of increase	1.24	1.24	1.22	1.25	(Mean = 1.24)

It has not proved possible to separate the instars easily on morphological features and so no attempt has been made to determine the proportions of instars present in the population on each sampling date, and hence the mortality in each instar. From the measurements made to determine the number of instars, it is possible to say, that instars one and two were present on 5 June 1961, instars two and three on 14 June, instars four and five on 18th July, and instar five

FIG. 28 **LOGARITHMIC PLOT OF THE DENSITIES OF
MACROSTELES SEXNOTATUS IN 1961 AND
1962.**

FIG. 28

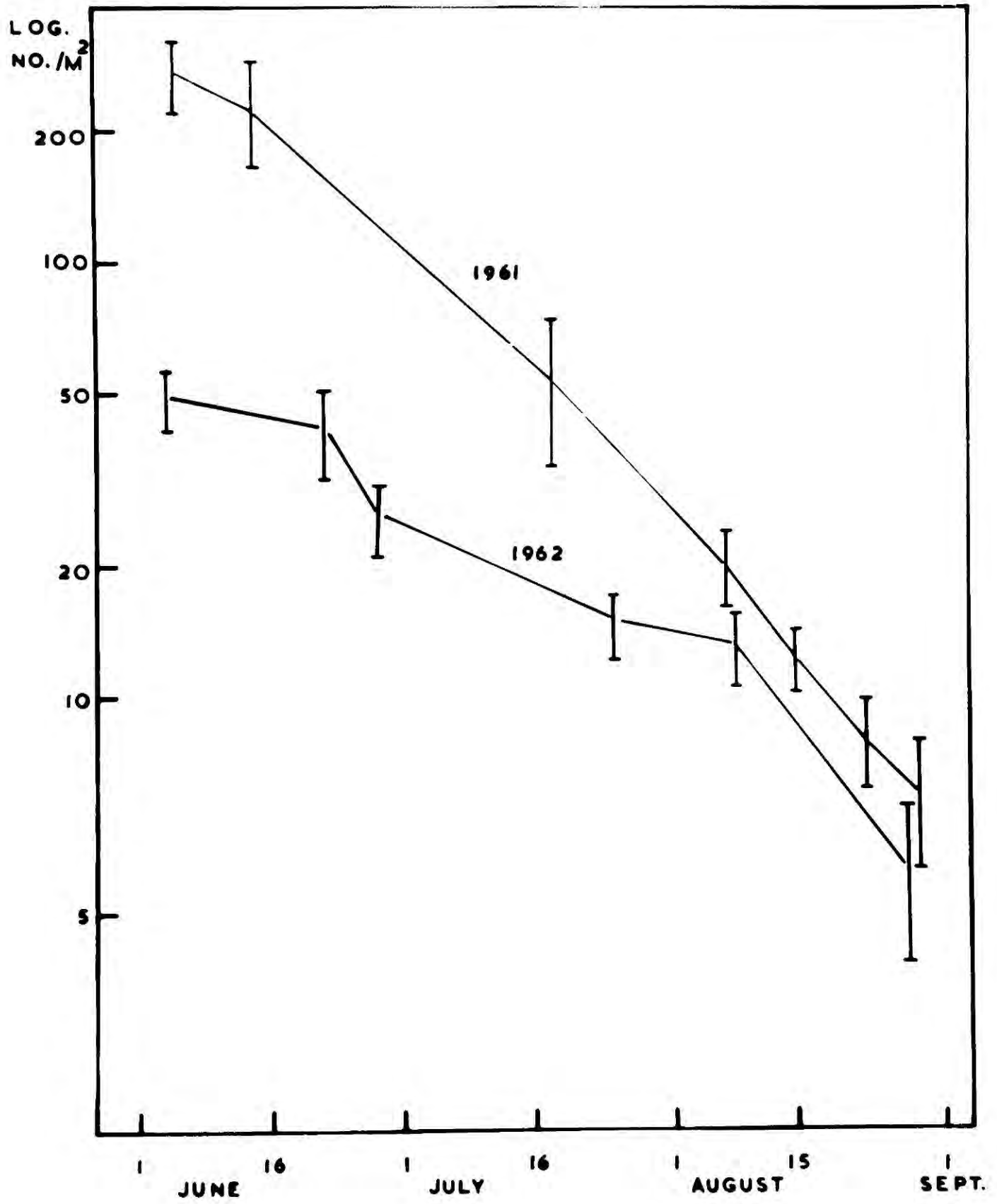

on 7 August. Adults first appeared in the population on 18 July.

The overall mortality of the population has been studied in 1961 and 1962 and the total numbers found on the sampling dates are recorded in Table 55. and shown graphically in Fig. 28. This shows that the mortality remains fairly constant in each of the instars. If 272 nymphs per square metre is taken as the population peak (on 5 June 1961), then when 50 per cent of the population has become adult (on about 1 August) the overall survival rate has been a maximum of only 0.12 over 56 days. In 1962, on the other hand, when the initial population density was only one fifth of that in 1961, the corresponding survival rate was approximately 0.27 over 52 days. The survival rate of adults, however, was similar in the two years (Fig. 28). There is insufficient data to discuss this point, although it may be an example of density-dependent mortality. If so, the mechanism allows wide fluctuations in numbers of M. sexnotata, because the initial 272 ± 54 per metre square in 1961, which fell to 49 ± 8 per square metre in 1962, fell again to 21 ± 5 in 1963, in common with the decreases in population densities in the species of Cercopidae so far discussed. Similarly, a second cicadellid (Psammotettix striatus) sampled on the limestone grass-land area had a maximum density in 1961 of 48 ± 6 per square metre, and only 28 ± 4 per square metre in 1962.

3. THE POPULATION DENSITY OF CONOMELUS ANCEPS.

The general features of the life cycle of this species of delphacid have been noted by Hassan (1939). He describes five

TABLE 55. POPULATION DENSITIES OF *M. SEXNOTATUS* AND *C. ANCEPS*,
ON THE JUNCUS SITE IN 1961 AND 1962.

Date	Number / metre square and S.E.	
	<i>M. sexnotatus</i>	<i>C. anceps</i>
1961		
June 5	272 \pm 54	700 \pm 132
14	225 \pm 64	1060 \pm 64
July 18	54 \pm 20	570 \pm 76
Aug. 7	20 \pm 3.8	221 \pm 29
15	12 \pm 2.5	175 \pm 24
23	8 \pm 2.0	85 \pm 15
29	6 \pm 2.0	61 \pm 12
Sept 6	4.5 \pm 1.7	47 \pm 8.3
11	4.5 \pm 1.5	53 \pm 6.9
1962		
June 4	49 \pm 8	7 \pm 3
22	42 \pm 10	94 \pm 22
28	26 \pm 4.7	-
July 25	14 \pm 3.4	26 \pm 7.7
Aug. 8	13 \pm 2.5	18 \pm 4.8
28	4 \pm 1.6	6 \pm 2.7
1963		
June 7	21 \pm 5.1	0
14	14 \pm 7.9	3.5 \pm 0.4

FIG. 29 **LOGARITHMIC PLOT OF THE DENSITIES OF
CONOMELUS ANCEPS IN 1961 AND 1962.**

FIG. 29

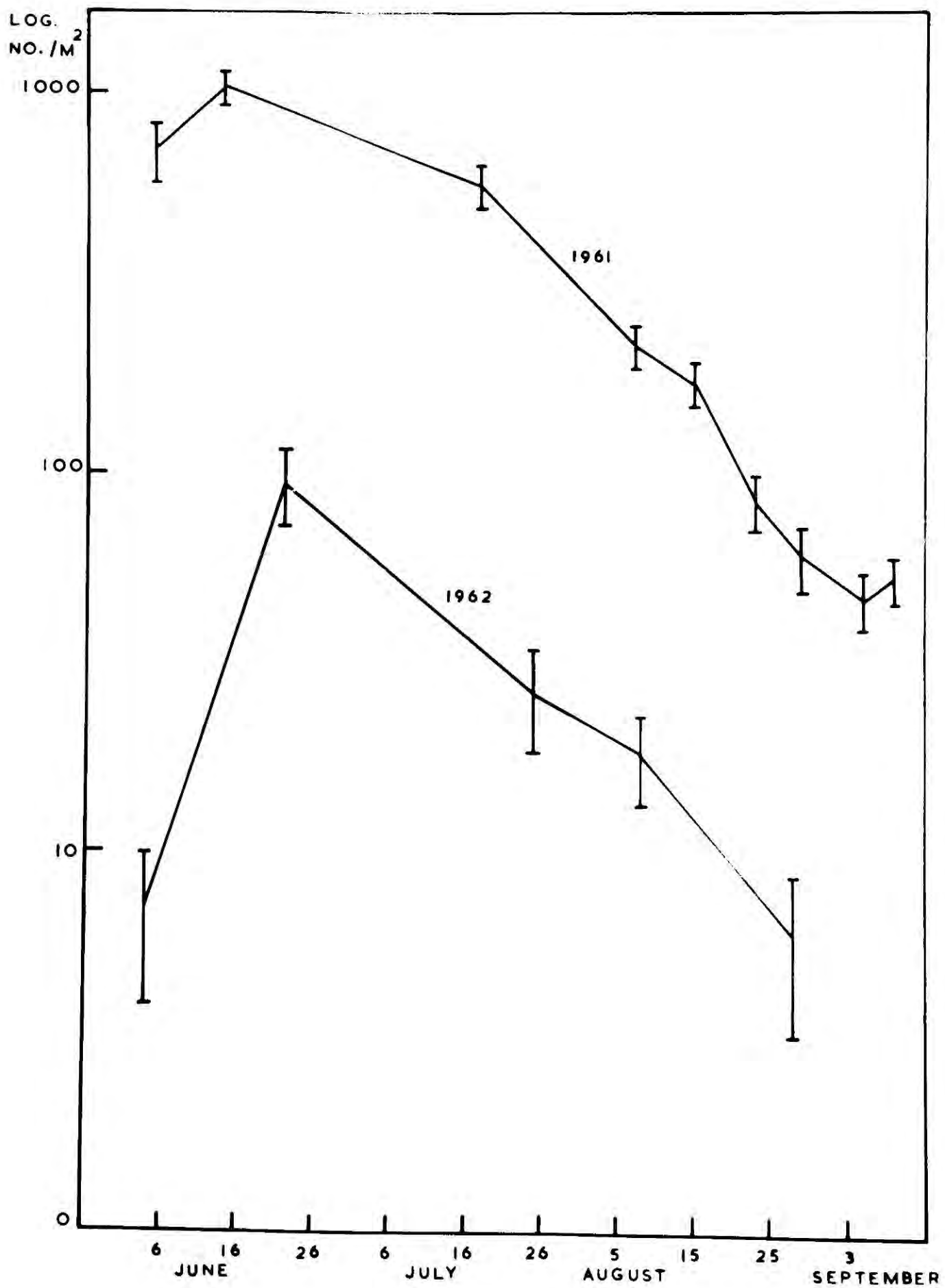

nymphal instars (in common with all the species of Auchenorrhyncha studied in the present account) and lists their occurrence (at the Imperial College Field Station, Slough, Bucks.), as being from the middle of May to the beginning of September, adults appearing in early July and continuing until late October. The species overwinters in the egg stage. At Moor House, nymphs were first observed in early June, but did not become adults until early August. These persisted in small numbers until October, so that the life cycle of the species at Moor House is only slightly different from that in lowland southern England. The population was sampled in two consecutive years (Table 55). In 1961, the peak population recorded was 1060 ± 128 nymphs per square metre but in 1962, this had fallen to 94 ± 22 . Fig. 29 shows that the survival rate was comparable in the two years (about 6 per cent up to the time of 50 per cent occurrence of adults i.e. over 70 and 67 days, respectively).

In 1963, the population on the Juncus site was too small to sample accurately. The maximum density occurred on 14 June, when there were 3.5 ± 0.4 nymphs per metre square.

4. COMPARISON OF THE MORTALITY IN THE NYMPHAL STAGES OF THE CERCOPIDAE, CICADELLIDAE AND DELPHACIDAE STUDIED.

The duration of the nymphal stages in N. lineatus, N. exclamatoris, Macrosteles sexnotatus and Conomelus anceps is approximately the same. It is therefore reasonable to compare their mortalities over the same time scale. The mortalities have been compared by constructing logarithmic plots of the M. sexnotatus and

C. anceps populations to compare with Fig. 26, and fitting regressions to the curves to estimate the average mortality over 50 days from the population peaks. The results are shown in Table 56.

TABLE 56. THE MORTALITY OF THE NYMPHAL STAGES OF ALL THE SPECIES STUDIED EXPRESSED AS A PERCENTAGE OVER FIFTY DAYS.

Species	Percentage mortality over 50 days	
	1961	1962
<u>N. exclamatoris</u>	-	85
<u>N. lineatus</u>		
a) on <u>Juncus</u>	85	82
b) on <u>Nardus</u>	88	86
<u>M. sexnotatus</u>	86	70
<u>C. anceps</u>	77	83

The densities of all the populations studied were much lower in 1962 than in 1961, but the nymphal mortalities were comparable in the two years, except in the case of M. sexnotatus. The mortality of the species without spittle (M. sexnotatus and C. anceps) is not markedly different in 1961 and 1962 respectively, from that of the species of Cercopidae studied, although M. sexnotatus had a slightly lower mortality in 1962 than the Cercopidae, and the mortality of C. anceps was slightly lower in 1961.

X. GENERAL DISCUSSION

In the following discussion, the present work is considered from two main aspects; the function of cercopid spittle, and the population dynamics of the species studied.

1. THE FUNCTION OF CERCOPID SPITTLE

Although the common names of "cuckoo-spit" or "crachat de grenouille" are still widely applied to the foam or spittle produced by many nymphal Cercopidae, it has long been recognised that the fluid is voided from the anus of the insect, and the mechanism of its production is no longer in any doubt (Sulc 1911, Gahan 1918 and Cecil 1930). It is now considered that the liquid is an anal exudate of similar composition to the juices of the host plant, but containing less sugar and amino acids because these have been utilised for nutriment (Wilson and Dorsey, 1958). This liquid appears at the anus shortly after the insect begins feeding (head downwards). When the nymph becomes partially submerged, bubbles are blown into the liquid from an "air-canal" formed by extensions of the abdominal tergites. These form an enclosed space under the abdomen into which air is drawn from outside the spittle. This air is then blown into the liquid, and the bubbles so formed are stabilised by a substance secreted by the Malpighian tubules (Licent 1912), or the abdominal glands of Batelli (Guilbeau 1908). Sulc (1911) claims that the waxy secretion of the glands of Batelli is acted upon by intestinal enzymes to produce a substance which stabilises the foam. Thus the foam is

not simply a bi-product of feeding, but is actively blown into froth and stabilised in order to produce a micro-environment.

The ability to remain in one position on the host plant is likely to be a great advantage to an insect which feeds by inserting mouth parts into the host. It would reduce the number of occasions on which a suitable feeding site has to be selected and the mouthparts inserted. Reference has been made elsewhere in this account to the work of Kloft (1960) and others, who have shown that after a time, the concentration of proteinaceous substances and carbohydrates is increased in the vicinity of the feeding punctures. Continued feeding at the same site may therefore be a physiological advantage.

Remaining stationary on vegetation would necessitate protection from predators or parasites, and from the effects of unfavourable microclimatic conditions such as the danger of desiccation. These two functions have been attributed to the spittle by several authors (e.g. Buckton 1890). Neither appear to have been examined critically, and the survival value of the spittle has not been demonstrated.

The foam will serve as protection from predators only if they do not associate its presence with that of the nymph. If such an association occurs, the foam will be a disadvantage, because it is much more easily seen than the nymph itself. There are several references to birds having been observed to take nymphs from spittles (e.g. Kalmbach 1919, 1940, Brindley 1934, Nolan 1956, Macklin 1958), but with one exception, these are records of isolated incidents.

Brindley (loc. cit) quotes Fincher who had observed house sparrows which "deliberately pecked them (P. spumarius nymphs) out of the "cuckoo-spit" and took a good beakful on each occasion". In spite of these instances, there is no evidence that birds systematically and commonly act as predators of cercopid nymphs. Although the meadow pipit (Anthus pratensis) is a common bird at Moor House, it has not been observed to take nymphs from spittle during the present study, and Coulson (pers. comm.), who has studied its feeding at Moor House, has no records of this. Other possible predators of the nymphs are uncommon on the sample sites studied, with the exception of spiders and the common frog (Rana temporaria). With regard to the former, Cherrett (1961) lists common food of the spiders at Moor House, but only discusses the Orb-Web builders. He did not find Cercopidae in their webs. He states that a lycosid, Lycosa pullata is common on Juncus squarrosus areas, but goes on to suggest that these wolf spiders may hunt by waiting for prey to come into their immediate vicinity. If this is so, they are unlikely to be important predators of cercopid nymphs. Thirty frogs have been collected whilst feeding on the sample sites, and dissected. Examination of the stomach contents revealed only one second instar nymph of N. lineatus, although the stomachs were often full of other invertebrates, especially slugs. There was no evidence that this nymph was taken from the spittle. In view of the wide occurrence of spittle, and its conspicuousness, it seems likely that records of

predation would be much more frequent than these if the spittle was not acting as a protective device. A considerable part of the nymphal mortality of N. lineatus at Moor House has not been explained. Whether or not this is due to predation, is impossible to say, although it may be that a proportion of the spittles are eaten or trampled by sheep grazing on the area. Sheep tend to eat only the tips of Juncus squarrosus, and thus leave intact the base of the rosettes, where spittles are usually found. Nevertheless, they may constitute an important mortality factor to early instars of N. lineatus and to N. exclamationis, occurring on Festuca.

Records of parasites of Cercopidae are even more scarce in the literature. No parasites have been found in nymphs, although Kontkanen (1950) described the occurrence of two specimens of P. spumarius adults in his samples, parasitised by dryinid larvae. He does not state how many specimens were examined, but as it is a very common insect, it seems likely that this represents a very low level of parasitisation. None of the specimens examined from Moor House showed signs of parasitism, although a small number of parasitised Cicadellidae were found. Dryinid parasites of such Auchenorrhyncha are common (Kontkanen, 1950, gives a figure of 62 per cent parasitisation of leafhoppers in July). The occurrence of parasites in Cercopidae is therefore negligible compared with other Auchenorrhyncha, and this suggests that the spittle is an efficient protective device against, for example, Dryinidae, which lay eggs in Homopterous nymphs.

The function of spittle as a microclimate protecting the nymph from desiccation is more easily verified. Buckton (1890) states that "the soft-bodied larvae live pretty secure from their enemies under this spume, and comparatively they are unaffected by the droughts of summer". Nymphs removed from their spittle do not survive long, and Weaver and King (1954) observed that newly hatched nymphs died quickly if unable to produce spittle. Many invertebrates are unable to survive in conditions of low humidity, and this may restrict their occurrence to moist environments. Thus woodlice and millipedes avoid desiccation by remaining moist, if not all of the time in a damp or humid environment (Cloudsley - Thompson 1962). For insects feeding on the succulent part of plants, such restrictions are impossible unless they are root feeders, such as the terrestrial larvae of the Tipulidae. The provision of a humid microclimate is therefore of the utmost importance to the soft bodied cercopid nymphs which feed on the aerial parts of their ~~main~~ hosts. Most insects which are so restricted, take advantage of existing microclimate conditions. Thus Nørgaard (1951) showed that Pirata piraticus could only survive in a Sphagnum bog if it took advantage of the temperature and humidity conditions of the stalk layer. N. lineatus, on the other hand, actively produces its own micro-environment and therefore avoids similar restriction.

Examples of regulation of the microclimate are relatively rare in insects, and are usually directed towards the production of favourable temperature conditions. Thus honey bees are known to regulate the temperature of their hives, and the army ant (Eciton sp.) controls

the temperature of its "nest" (formed by the ants own bodies clustered together), by the activities of the workers (Schneirla et. al. 1954). The production of a humid microclimate by Cercopidae has the disadvantage of making them less mobile than, for example, Cicadellidae, and therefore more susceptible to changes in the temperature of the environment. The presence of marked temperature gradients in the vegetation at Moor House has been demonstrated (for example, 4 Centigrade degrees in 5 cm.). The suggested cooling (by evaporation) and temperature buffering effects of the spittle may therefore be important in allowing the nymph to remain stationary on its host, at least through a greater range of external temperature than in the case of other Auchenorrhyncha. If as much vertical movement was necessary as seems to occur in other Auchenorrhyncha, any protective properties of the spittle would be useless, as the nymph would be continually evacuating it.

In the present study it has been found that the survival of nymphs protected by spittle is no greater than that of nymphs of other Auchenorrhyncha. In a sub-arctic climate it seems likely that the possible disadvantages of immobility, such as availability to predators and the necessity to change host plants, are only just counteracted by the advantages conferred upon the nymph by possessing a spittle. Cercopidae are in general not as numerous in the Palaeartic region as other Auchenorrhyncha, and in fact, only a few genera penetrate this region. It may be therefore, that the evolution of the spittle was in response to conditions of low humidity and high temperatures where the function of the spittle as a microclimate may be of

considerable survival value. A parallel study carried out in such conditions would elucidate this point.

To conclude that the spittle is of no survival value at Moor House, because the survival rate of nymphs with spittle is no higher than those without, would be erroneous, since it has not been possible to evaluate all other mortality factors. To compare the survival of a species of cercopid (N. exclamationis) which does not vacate its spittle, with one which does (N. lineatus), does not indicate the survival value of the spittle. It is, however, reasonable to conclude that because the survival of nymphs of N. lineatus is less (by as much as 3 per cent per day) in the instars in which a change of host occurs, (no matter in which instar this does take place), that the nymph is less likely to survive when searching for a new host plant, and thus not surrounded by spittle. Whether this is due to predation or desiccation cannot easily be determined, except that desiccated bodies of nymphs have been found during this move.

The present study therefore indicates that the spittle is of some survival value to the nymph at Moor House by enabling it to avoid parasites, if not predators, and unfavourable climatic conditions encountered whilst remaining stationary on the host during feeding. These advantages are not sufficient at Moor House to give the Cercopidae a significantly higher survival rate than other Auchenorrhyncha.

2. POPULATION DYNAMICS

Since the pioneer study by Howard and Fiske (1911) in which the

concept of density dependent mortality was first introduced, a great body of literature has accumulated on the factors limiting populations of animals. Most of this literature has been divided into what may conveniently be called the Andrewartha and Birch, or the Nicholson schools.

From his study of Austroicetes cruciata, and a consideration of the fluctuations recorded in various other insect populations, Birch (1957) concludes that "the fluctuations of weather in relation to spatial patchiness of the animal's environment, can regulate numbers in the sense of preventing unlimited increase and of avoiding the certainty, though not the possibility, of extinction!" The conclusions of Klomp (1962) are in contradiction to this statement. Basing his argument on theoretical considerations, he concludes that the action of factors which will "effect the destruction of a greater proportionate number of individuals as the insect in question increases in abundance" (Howard and Fiske, 1911) is essential for the regulation of the density of animal populations. This is essentially a re-statement of the opinions of Nicholson (1954), who has demonstrated the action of density dependent factors regulating artificially established populations of blowflies (Lucilia cuprina). From these, and other data, he concludes that "any species automatically adjusts its density in different places, and in the same place at different times, in relation to the prevailing environmental conditions, and it maintains a state of stability under all conditions which are not inherently intolerable". Klomp (loc. cit.) concludes that "the

regulation of the density of animal populations by density independent weather factors as such is clearly an impossibility".

On the face of it, these basic theories are in contradiction, but as Varley (1963) has pointed out, they are not irreconcilable because their difference is largely one of definition. A useful approach is that of Morris (1959) in which he considers the factors affecting the abundance of a species to be of two types. There will be those factors which are causing a relatively constant mortality from year to year and are thus making little contribution to the population variation. Secondly, there are factors which are causing a variable mortality and are thus largely responsible for the changes in the population. He introduces the term "Key-factor" for these latter. In Birch's example of Austroicetes, the weather may be described as a Key-factor since it is largely responsible for the changes in the population. Such a factor is not density dependent and cannot, according to Klomp, be a stabilising influence on the population. It does not therefore "regulate" the population density, as Birch claims, but is simply responsible for "changes" of the type described by Morris. This point has been made by Varley (1963). Any density dependent mechanism must be distinct from this Key-factor, although it may operate in consequence of population changes brought about by it. Thus Nicholson, in his Lucilia experiment, introduced a Key-factor by removing varying populations of adults from the cultures. He found that the remaining adults laid proportionately more eggs because competition for food was lessened and proportionately more adults obtained sufficient nutriment for the development of eggs.

Similarly, he found that if food was limiting to the larvae, increased destruction of emerging adults led to an increased daily emergence of adults because there was reduced larval competition for food, resulting from fewer eggs having been laid. Thus there was compensation for the effect of the Key-factor, and this compensation was related to the population density. It may be argued that some such regulating factor operated also in the case of Austroicetes to hold the populations at a level about which fluctuations due to Key-factors occurred, although local extinction of the species occurred at the edge of the range (Birch 1957). It may be mentioned here that the term "population" is being used in the present account in the sense in which it was defined by Richards (1961) : "all those individuals of a species whose lives are sufficiently integrated to have an influence on one another".

It has been suggested that part of the difference in population densities of N. lineatus and N. exclamationis in 1961 and 1962 at Moor House was due to the catastrophic effect of climatic factors acting on adults prior to oviposition. Similar reductions in density from year to year were recorded in each of the species studied. Unfavourable climatic conditions may be considered as a Key-factor in Morris's sense in that they are partially responsible for the observed changes in population density from year to year. Uvarov (1931) has said that "any temporary deviations of the climatic factors, however slight they may be, affect the percentage of survival, either directly or indirectly (through natural enemies and food plants) and thus influence abundance". Morris's other class of factors seem to operate

during the nymphal stages of development since mortality remained constant, at any rate during the two years studied. Thus the average survival per day of N. lineatus on the Juncus site was 97.3 per cent in 1961, and 96.3 per cent in 1962, although the maximum densities recorded in the two years were 143 and 14 nymphs per square metre, respectively. Similarly, on the Nardus site, the average survival per day was 97.5 per cent in 1961, and 97.2 per cent in 1962. The mortality during the nymphal stages was, therefore apparently independent of the population density. It is hard to see how the catastrophic effect of climate could act in a density dependent manner, or, if it is acting in the same way as the artificial predation in Nicholson's experiment, how it is compensated for in other stages of the life cycle. It has already been mentioned that predation and parasitism do not appear to be very important at Moor House, and Cragg (1961) has stated that predation by itself appears to have a negligible effect on the numbers of dominant moorland insects. Kontkanen (1950) is of the opinion from his studies of the parasites of Auchenorrhyncha that the species living in wet biotopes have a much lower incidence of parasitism than those in dry ones. There was no evidence that the Auchenorrhyncha at Moor House approached a state of being limited by food requirements.

These facts raise the important question discussed by Reynoldson (1957) of whether density dependent factors are operative in a favourable environment where the population is likely to increase beyond a point where some requisite is in short supply, but do not

operate in a population which is in an unfavourable environment and does not increase to such a point. Much the same point was made by Crombie (1947) when he said of the physical environment that "it may adversely affect the competitors, but not their food, living space, etc., so that the ratio of population to resources remains low. This occurs in unfavourable habitats..." Many authors have to some degree or other, subscribed to this view. Nørgaard (1956) attributed population fluctuations of Theridion saxatile to destructive weather conditions which seemed to act independently of the population size. Richards (1961) states that "at the extreme edge of the range of a species, chance will play an increasing part in control". This general view has been challenged, however, by Huffaker (1956), who subscribes to the view that "those advocates of density dependent actions are wrong who have argued that climate controls populations near to the limits of distributions, while density dependent actions determine events near the centre".

In his review of population studies at Moor House, Cragg (1961) doubts whether regulation of numbers is of any significance in such a harsh environment where the extinction of local populations is of frequent occurrence. It may be that under such conditions, there is no mechanism to prevent the chance extinction of a local population, but density dependent factors begin to operate if the population is allowed, by chance, to increase to a point where its members are in competition for some requisite. That is, if the environment becomes temporarily favourable. Extinction of local populations is a fairly common occurrence at Moor House. For

example, it was shown to occur at the edge of the range of Coleophora alticollela Zell. by Jordan (1962), and within the range of Tipula subnodicornis Zett. by Coulson (1962). In northern England, the altitude which N. lineatus is able to reach is determined by the time of year at which favourable development conditions commence, and the duration of the favourable season. Individuals of N. lineatus at 2,700 feet had laid eggs in 1960 since August and September were mild enough to enable the adult females to survive until after copulation and oviposition. The nymphs hatching from these eggs did not complete their development in 1961 because the favourable season was much shorter. The upper range of the species was therefore reduced to 2,500 feet. This is an example of an insect whose altitudinal range is limited in northern England by climatic factors, but it simply represents an "edge" effect which merely depresses the range of the species. N. lineatus occurring on the Juncus site may constitute a slightly different case because it is felt that they may, according to Richard's definition, be termed a population since the site is surrounded by unfavourable habitats which limit immigration or emigration because adult N. lineatus are unable to fly. It is suggested that after the unfavourable periods which have been recorded in this work, the local population is in danger of becoming extinct unless it survives in favourable "pockets" created by any heterogeneity of the area. A succession of years with more favourable conditions would then be necessary to increase the density level to a point where regulating mechanisms may operate again. The present study provides no evidence that such regulating mechanisms were

operative even in 1961, when the highest population density was recorded. Further detailed studies, particularly of fecundity would be necessary to demonstrate this conclusively.

It seems likely that non-density dependent factors are responsible for a major part of the changes in population density from year to year. Failure to show a compensatory mechanism at some other stage of the life cycle does not, however, preclude its presence. Low population densities in 1962 and 1963 made impossible the detailed studies necessary to elucidate this problem.

SUMMARY

1. A study of the Homoptera - Auchenorrhyncha of the Moor House National Nature Reserve, Westmorland was made from 1961 to 1963. Particular attention was paid to the Cercopidae.
2. No previous records of the Auchenorrhyncha of the Reserve have been made, and in the present study, 32 species were collected. Notes on the taxonomy and autecology of the species are given.
3. A method of quadrat sampling allowing estimation of numbers of nymphs and spittles per unit area is described for the spittle-producing nymphs of the Cercopidae. Adult Cercopidae and other Auchenorrhyncha were collected quantitatively by means of a portable vacuum extractor, and qualitatively by a sweep net.
4. The microclimates of the various vegetation types sampled are described. The conditions necessary for the development of gradients of temperature are shown to occur on only about 25 days during the months (June to September) when Auchenorrhyncha are present at Moor House. Saturation Deficit differences of 4 mm. Hg. and temperature gradients of 4 Centigrade degrees were recorded within a vertical distance of 5 cm.
5. It is shown that the size of the spittle produced by cercopid nymphs is largely dependent on its position with respect to the humidity gradient; larger spittles being found nearer to the ground surface. It is suggested that cercopid spittle

buffers fluctuations in the temperature of the environment, and cools the nymph under conditions of high temperature and low humidity.

6. Vertical movements in the vegetation are made by *Auchenorrhyncha* without spittle, in order to avoid high temperatures.
7. The existence of five (not as previously thought, four) instars is shown in nymphs of *N. lineatus*, a cercopid occurring on *Juncus squarrosus* and *Nardus* areas.
8. The durations of these instars are shown to range from 19 days (instar one) to 13 days (instar 3) under the 1961 climatic conditions. It is also shown by laboratory experiments and field data that the duration of instars varies inversely with temperature.
9. The spatial distribution of *N. lineatus* is described, and it is shown that nymphs on *Juncus* and *Nardus* show fluctuations in the degree of aggregation, which correspond with the peak occurrence of the instars. It is concluded that the nymphs change feeding sites after moulting.
10. A change of host species is demonstrated on the *Juncus* site studied, from *Festuca* in the early instars, to *Juncus squarrosus* in the later ones. Aggregations of nymphs within spittles occurred on *Juncus* hosts whether the population density was relatively high (c.45/m² in 1961) or low (c.10/m² in 1962). It is suggested that increase in size

of the mouth-parts may be the reason for the change of host.

11. The mortality of nymphs is demonstrated to be 3 per cent per day higher in those instars in which the change of host occurs. The overall nymphal mortality is comparable (about 85 per cent) on each of the sample sites in each year, irrespective of the population density.
12. Early instars of N. lineatus have a comparable survival rate when experimentally confined on either Festuca or Juncus, but later instars have a 30 per cent higher survival rate on Juncus than on Festuca.
13. The sex ratio of adult N. lineatus does not differ significantly from equality.
14. A catastrophic reduction in the density of adult N. lineatus in 1961 is attributed to the flooding of the sample site.
15. Copulation in N. lineatus is described and shown to occur between 20 and 30 days after the first appearance of adults in the population.
16. Maturation of eggs is described and it is shown that probably only one batch of up to 20 eggs is matured. Eggs are mature when copulation takes place, and oviposition occurs shortly afterwards.
17. N. lineatus overwinters in the egg stage, and 7.0°C. is shown to be the threshold temperature for egg development.
18. Egg mortality is estimated to be a maximum of 35 per cent.
19. The hatch of N. lineatus is progressively delayed, and

- development is progressively retarded at higher altitudes.
20. A second species of cercopid, N. exclamationis, occurring on limestone grassland, has five nymphal instars. Development to the adult was completed in seven days less in 1961, than in the case of N. lineatus.
 21. Very little movement of nymphs of N. exclamationis was found, and their survival rates were comparable in each instar (about 98 per cent per day), and higher than that recorded for those instars of N. lineatus which change host plants.
 22. The limestone grassland area has a series of hummocks and hollows caused by upstanding blocks of limestone. The density of adult N. exclamationis was found to be three times as high on the hummocks than in the hollows, and it is suggested that this is a result of the different vegetation and micro-climates of the two habitats.
 23. Catastrophic reductions in the densities of adult N. exclamationis accounting for 80 per cent of the adult mortality are attributed to frosts.
 24. A comparison of the occurrence of polymorphic colour forms of a third cercopid, Philaenus spumarius is made with lowland populations in Britain, and a population in Finland. The Moor House population has a significantly lower proportion of one of the varieties (trilineata), than in lowland Britain, but compares in this respect with the Finnish population.

25. In 1961 the peak population density of Macrosteles sexnotatus (Cicadellidae) was 272 per metre square. The peak in 1962 was 49 per metre square, and was 21 per metre square in 1963.
26. In 1961 the peak population density of Conomelus anceps (Delphacidae) was 1060 per metre square. The peak in 1962 was 94 per metre square and was 3.5 per metre square in 1963.
27. Nymphal mortality rates in both species in each year did not differ markedly from those of the Cercopidae studied.
28. The function of cercopid spittle as a protector from predators, parasites and unfavourable climatic conditions is examined. It is concluded that the spittle is of some survival value at Moor House by enabling the nymph to avoid parasites, if not predators, and unfavourable climatic conditions encountered whilst remaining stationary on the host during feeding. These advantages are not sufficient to give the Cercopidae a significantly higher survival rate than other Auchenorrhyncha at Moor House.
29. Non-density dependent factors are thought to be responsible for a major part of the changes in population density from year to year. A compensatory mechanism at other stages of the life history has not been demonstrated. Local extinction at the edge of the range is a result of climatic factors. It is considered that a succession of years with more favourable conditions would be necessary to allow the density of a discrete population (on the Juncus site) to increase to a level where regulating mechanisms may occur.

REFERENCES

- Ahmed, D. D. et. al. 1952. Tests for control of meadow spittlebugs in Ohio. *J. econ. Ent.* 45 : 417-420
- Benson, R. B. 1950. An Introduction to the Natural History of British Sawflies (Hymenoptera, Symphyta). *Trans. Soc. Brit. Ent.* 10(2) : 45-142
- Birch, L. C. 1957. The Role of Weather in Determining the Distribution and Abundance of Animals. *Cold Spr. Harb. Symp. quant. Biol.* 22 : 203-215
- Blackman, G. E. 1942. Statistical and ecological studies in the distribution of species in plant communities. I. Dispersion as a factor in the study of changes in plant populations. *Ann. Bot. Lond.* 22(VI) : 351-370
- *Blankaart, S. 1690. Schouburg der Repsen Wormen Maden en vliegende Dierkens. 178 pp. Leipsig.
- *Bock (sixteenth century) in Gruner, M. 1901. Biologische Untersuchungen an Schaumcikaden. Inaugural dissertation. Berlin.
- Boring, A. M. 1913. The chromosomes of the Cercopidae. *Biol. Bull., Wood's Hole.* 24 : 133-146
- Bowden, B. N. 1958. The Radiation error of Air Temperature Measurement by Stantel Type F. thermistors and simple methods to reduce it. *J. Ecol.* 46 : 143-148

- Brinck, P. 1949. Studies on Swedish stoneflies. Opusc. Ent. Suppl., 11 : 250 pp.
- Brindley, M. D. 1934. Sparrows feeding young on "Cuckoo - spit" (Homoptera, Cercopidae). Proc. R. ent. Soc. Lond. 2 : 69.
- Brinkhurst, R. O. 1959. Alary polymorphism in the Gerroidea (Hemiptera - Heteroptera). J. Anim. Ecol. 28 : 211-230
- Broadbent, L. 1950. The Microclimate of the Potato Crop. Quart. J. R. met. Soc. 76 : 439-454
- Buckton, G. B. 1890. Monograph of the British Cicadae, or Tettigiidae. 211 pp. London
- Cecil, R. 1930. The alimentary canal of Philaenus leucophthalmus L. Ohio J. Sci. 30 : 120-130
- Chadwick, M. J. 1960. Biological flora of the British Isles : Nardus stricta. J. Ecol. 48 : 255-267
- Chamberlain, T. R. and J. T. Medler 1950. A comparison of methods for estimating populations of spittlebug nymphs in alfalfa. J. econ. Ent. 43 : 731-732
- Cherrett, J. M. 1961. Ecological research on Spiders associated with Moorlands. Thesis : Durham University Library.
- China, W. E. 1950. A check list of the British Hemiptera - Homoptera Auchenorrhynca. Ent. mon. Mag. 86 : 243-51.

- China, W. E. 1951. Corrections to the check list of the British Hemiptera - Homoptera. Ent. mon. Mag. 87 : 280
- Clapham, A. R. 1936. Over Dispersion in Grassland Communities and the use of Statistical Methods in Plant Ecology. J. Ecol. 24 : 232-251
- Cloudesley - Thompson, J. L. 1962. Microclimates and the Distribution of Terrestrial Arthropods. Ann. Rev. Ent. 7 : 199-222
- Conway, V. M. 1955. The Moor House National Nature Reserve, Westmorland. Handb. Soc. Prom. Nat. Res. 1-7
- Coulson, J. C. 1959. Observations on the Tipulidae (Diptera) of the Moor House Reserve. Trans R. ent. Soc. Lond. 3 : 157-74
- Coulson, J. C. 1962. The biology of Tipula subnodicornis Zetterstedt with comparative observations on Tipula paludosa Meigen. J. Anim. Ecol. 31 : 1-21.
- Cragg, J. B. 1961. Some aspects of the ecology of Moorland Animals. J. Anim. Ecol. 30 : 205-234
- Crombie, A. C. 1947. Interspecific Competition. J. Anim. Ecol. 16 : 44-73
- De Long, D. M. 1932. Some problems encountered in the estimation of insect populations by the sweeping method. Ann. ent. Soc. Amer. 25 : 15-17

- Dempster, J. P. 1956. The Estimation of the Number of Individuals entering each stage during the development of one generation of an Insect Population. *J. Anim. Ecol.* 25 : 1-5
- Dietrick, L. J. et. al. 1960. A new method for sampling Arthropods using a suction collecting machine and modified Berlese funnel separator. *J. econ. Ent.* 52 : 1085-1091
- Duarte, A. J. 1939. Problems of growth of the African migratory locust. *Bull. ent. Res.* 29 : 425-456
- Dyar, H. G. 1890. The number of moults of Lepidopterous larvae. *Psyche, Camb. Mass.* 5 : 420-422
- Edwards, J. 1896. The Hemiptera - Homoptera of the British Islands. 271 pp. London
- *Ekblom, T. 1941. Untersuchungen uber der Flugpolymorphismus der Gerris asper. *Notul. ent., Helsingf.* 21 : 49-64
- Evans, F. C. and Lanham, V. N. 1960. Distortion of the Pyramid of Numbers in a Grassland Insect Community. *Science* 131 : 1531-2
- Everly, R. T. 1959. Evaluation of Population Estimates and the rate of loss of forage for the Meadow Spittlebug, Philaenus leucophthalmus. *Proc. Ind. Acad. Sci.* 68 : 171-185.
- *Fabre, J. H. 1900. La Cicadelle ecumeuse. *Souvenirs entomologiques. (Septieme Series)* : 239-54

- Gabbutt, P. D. 1959. The Bionomics of the Wood Cricket,
Nemobius sylvestris (Orthoptera ; Gryllidae)
J. Anim. Ecol. 28 : 15-42
- Gahan, C. J. 1918. Method of formation of "Cuckoo spit" by
Philaenus spumarius. Proc. ent. Soc. Lond. 1918 :
153 - 5
- Garman, P. 1921. The grass-feeding frog-hopper or spittlebug.
Bull. Conn. agric. Exp. Sta. 230 : 327-334
- Geiger, R. 1959. "Das Klima der bodennahen Luftschicht"
(Die Wissenschaft, Braunschweig, 1927. 2nd Edn. 1942)
Translation of 2nd Edn. revised by the author
entitled "The Climate Near the Ground".
Harvard University Press, 1951
- Glasgow, J. P. 1939. A population study of subterranean soil
Collembola. J. Anim. Ecol. 8 : 323-353
- Greig-Smith, P. 1952a. The use of random and contiguous
quadrats in the study of the structure of plant
communities. Ann. Bot., Lond. N.S. 16 : 293-316
- Greig-Smith, P. 1957. Quantitative Plant Ecology, London.
- Guilbeau, B. H. 1908. The origin and formation of the froth
in spittle-insects. Amer. Nat. 42 : 783-798
- Halkka, O. 1962. Polymorphism in Populations of Philaenus
spumarius close to equilibrium. Ann. Acad. Sci.
fenn. A IV, 59 : 1-22

- Hassan, A. I. 1939. The Biology of some British Delphacidae (Homopt.) and their parasites, with special reference to the Strepsiptera. Trans. R. ent. Soc. Lond. 89 : 345-84
- Hömgren, N. 1899. Beiträge zur Kenntniss der weiblichen Geschlechtsorgane der Cicadarien. Zool. Jahrb. System. 12 : 403-410
- *Horvath, G. 1898. Remarques Synonymiques sur les Hemipteres Palaearctiques. Rev. Ent., Caen. 17 : 275-81
- Hovanitz, W. 1941. Parallel ecogenotypical color variation in butterflies. Ecology 22(3) : 259-284
- Howard, L. O. and Fiske, W. F., 1911. The importation into the United States of the parasites of the gypsy moth and the brown tail moth. Bull. U.S. Bur. Ent., 91 : 312 pp.
- Huffaker, C. B. 1956. The Concept of Balance in Nature. Int. Congr. Ent. X. : 625-636
- Hughes, R. D. 1955. The influence of the prevailing weather on the numbers of Meromyza variegata Meigen (Diptera Chloropidae) caught with a sweep net. J. Anim. Ecol. 24 : 324-35
- Hynes, H. B. N. 1941. The taxonomy and ecology of the nymphs of British Plecoptera with notes on the adults and eggs. Trans. R. ent. Soc. Lond. 91 : 459-556

- Hynes, H. B. N. 1955. Biological notes on some East African aquatic Heteroptera. Proc. R. ent. Soc. Lond.
30 : 43-54
- Imms, A. D. 1921. The Froghopper problem in Trinidad.
Nature 124 : 558-9
- Johnson, C. G., Southwood, T. R. E. and Entwistle, H. M. 1957.
A new Method of Extracting Arthropods and Molluscs from grassland and herbage with a suction apparatus.
Bull. ent. Res. I 48 : 211-218
- Johnson, G. A. L. and K. C. Dunham 1963. The Geology of Moor House. Monographs of the Nature Conservancy Number Two. H.M.S.O.
- Jordan, A. M. 1962. Coleophora alticolella Bell. (Lepidoptera) and its food plant Juncus squarrosus L. in the northern Pennines. J. Anim. Ecol. 31 : 293-304
- *Jordan, K. H. C. 1943. Flugopolymorphismus in Gerris odontogaster. Arb. morph. taxon. Ent. Berl.
10 : 157-63
- *Kalmbach, E. R. 1919. The crow recorded as a predator of Homoptera. Bull U.S. Dep. Agric. 621 : 1-32
- *Kalmbach, E. R. 1940. The sparrow recorded as a predator of Homoptera. Tech. Bull. U.S. Dep. Agric. 711 : 1-66
- Kennard, W. C. and J. L. Spencer 1955. A mechanical insect collector with high maneuverability. J. econ. Ent.
48 : 478-79

- Kloft, W. 1957. Further investigations concerning the inter-relationship between the condition of Abies alba and infestation by Adelges piceae typica and A. nusslini schneideri. Z. angew. Ent. 41 : 438-442
- Kloft, W. 1960a. Wechselwirkungen zwischen pflanzensaugenden Insekten und den von ihnen besogenen Pflanzengeweben. Z. angew. Ent. 45 : 337-381 and 46 : 42-70
- Klomp. H. 1962. The influence of climate and weather on the mean density level, the fluctuations and the regulation of animal populations. Arch. neerl. Zool. 15 : 68-109
- Kontkanen, P. 1950. Notes on the parasites of leafhoppers in North Karelia. Ann. ent. fenn. 16 : 101-109
- Kontkanen, P. 1950. Quantitative and seasonal studies on the leafhopper fauna of the field stratum on open areas in North Karelia. Ann. Zool. Soc. fenn. 13(8) : 1-91
- Lake, J. V. 1956. The temperature profile above bare soil on clear nights. Quart. J. R. met. Soc. 82 : 187-197
- Le Quesne, J. 1960. Royal Entomological Society of London. Handbooks for the identification of British Insects Vol. II pt. 3 Hemiptera, Fulgoromorpha. pp. 68
London

- Licent, P. E. 1912. Recherches d'anatomie et de physiologie comparees sur le tube digestif des Homopteres superieurs. Cellule. 28(1) : 5-161
- Lindberg, H. 1929. Vingdimorphism in nos Hemiptera Heteroptera. 18 Scand. Naturalists Congr. (Copenhagen)
- Linnavuori, R. 1952. Studies on the ecology and phenology of the leafhoppers (Homoptera) of Raisio (S.W. Finland). Ann. zool. Soc. fenn. 14 : 1-32
- Macfadyen, A. 1957. Animal ecology, Aims and Methods. Pitman, London
- Macklin, P. R. 1958. Spittle insects as food of the red-winged blackbird. Auk 75 (1) : 225
- Manley, G. 1936. The climate of the northern Pennines; the coldest part of England. Quart. J. R. met. Soc. 62 : 103-15
- Manley, G. 1942. Meteorological observations on Dun Fell, a mountain station in northern England. Quart. J. R. met. Soc. 68 : 151
- Manley, G. 1943. Further climatological averages for the northern Pennines, with a note on topographical effects. Quart. J. R. met. Soc. 69 : 251-261
- Marshall, D. S. and Gyrisco, G. G. 1951. Control of the meadow spittlebug on forage crops. J. econ. Ent. 44 : 289-293.

- Metcalfe, M. E. 1932. Notes on the structure and development of the reproductive organs in Philaenus spumarius (L). *Quart. J. micro. Sci.* 75 : 467-481
- Morris, R. F. 1959. Single factor analysis in population dynamics. *Ecology* 40 : 580-8
- Nicholson, A. J. 1954. Compensatory reactions of populations to stresses, and their evolutionary significance. *Austr. J. zool.* 2 : 1-8
- Nolan, V. 1956. Spittle insects as food of the Prairie Warbler. *Auk* 73(4) : 557
- Nørgaard, E. 1951. On the ecology of two Lycosid spiders (Pirata piraticus and Lycosa pullata) from a Danish Sphagnum bog. *Oikos* 3 : 1-21
- Nørgaard, E. 1956. The environment and behaviour of Theridion saxatile. *Oikos* 7 : 159-192
- Nuorteva, P. 1952. Die Nahrungspflanzenwahl der Insekten im Lichte von Untersuchungen an Zikaden. *Ann. Acad. Sci. fenn. A IV*, 19 : 1-90
- Nuorteva, P. 1962. Studies on the causes of the Phytopathogenicity of Calligypona pellucida (F) (Hom. Araeopidae). *Ann. zool. Soc. fenn.* 23 : 1-58.
- Osborn, H. 1916. Studies of life histories of froghoppers of Maine. *Bull. Me agric. Exp. Sta.* 254 : 265-288
- Ossiannilsson, F. 1946-47. 7 Halvvingar. Hemiptera. Stritar Homoptera Auchenorrhyncha. *Svensk Insektfauna. Entomologiska Foreningen I Stockholm* 36 : 1-150

- Ossiannilsson, F. 1948. Catalogus Insectorum Sueciae. VIII.
Hemiptera Homoptera Auchenorrhyncha (Cicadina).
Opusc. Ent. 13 : 1-25
- Ossiannilsson, F. 1957. The lectotype of Cicada spumaria
L., 1758. Opusc. Ent. 22 : 66
- Pearsall, W. H. 1950. Mountains and Moorlands. Collins,
London
- Penman, H. L. and I. Long 1949. A portable Thermistor Bridge
for Micro-meteorology among growing crops.
J. sci. Instrum. 26 : 77-80
- Perkins, R. C. L. 1905. Leaf-hoppers and their natural
enemies. Bull. Hawaii. Sug. Ass. ent. Ser.
I(4) : 123-157
- Pickles, A. 1934. Entomological contributions to the study
of the sugar-cane froghopper. Reprint of Pickles
1933a. Trop. Agriculture, Trin. 10 : 222-233
- Powell, R. W. 1936. The use of Thermocouples for Psychrometric
Purposes. Proc. phys. Soc. Lond. 48 : 406-414
- *Remane, R. 1958. Die Besiedlung von Grunlandflachen verschiedener
Herkunft durch Wangen und Zikaden im Weser - Ems -
Gebiet. Z. angew. Ent. 42 : 353-400
- Reynoldson, T. B. 1957. Population fluctuations in Urceolaria
mitra (Peritricha) and Enchytraeus albidus
(Oligochaeta) and their bearing on Regulation.
Cold Spr. Harb. Symp. quant. Biol. 22 : 313-324

- Ribaut, H. 1952. Faune de France 57. Homopteres
Auchenorrhynques. II (Jassidae). pp. 474 Paris.
- Richards, O. W. 1940. Larval mortality in Pieris rapae.
J. Anim. Ecol. 9 : 243-288
- Richards, O. W. 1949. The relation between measurements
of the successive instars of insects. Proc. R.
ent. Soc. Lond., (A), 24 : 8-10
- Richards, O. W. 1961. The Theoretical and Practical Study
of Natural Insect Populations. Ann. rev. Ent.
6 : 147-162
- Richards, O. W. and N. Waloff 1954. Studies on the biology
and population dynamics of British Grasshoppers.
Anti-locust Bull. 17 : 182 pp.
- Robertson, A. and A. J. Gibbs 1937. Spermatogenesis and
fertilisation in Philaenus spumarius Fallen.
J. trop. Med. (Hyg.) 40 : 257-262
- Salt, G. and F. S. J. Hollick 1946. Studies on Wireworm
Populations II. Spatial Distribution.
J. exp. Biol. 23 : 1-46
- *Schneirla, et. al. 1954. The bivouac or temporary nest as
an adaptive factor in certain terrestrial species
of army ants. Ecol. Monogr. 24 : 269-96
- Skellam, J. G. 1952. Studies of statistical ecology. I
Spatial pattern. Biometrika, 39 : 346-362

- Southwood, T. R. E. and Pleasance, H. J. 1962. A hand-operated suction apparatus for the extraction of Arthropods from grassland and similar habitats, with notes on other models. Bull. ent. Res. I. 53 : 125-128
- Sulc, K. 1911. Respiration, trachaensystem und Schaumproduction der Schaumcicaden Larvae, Aphrophora, (Homoptera) Z. wiss. Zool. 99 : 147-188
- *Svedberg, T. 1922. Ett bidrag till de statistiska metodernas anvandning inom vaxtbiologien. Svensk. bot. Tidskr., 16 : 1-8
- *Tanada, Y. and F. G. Holdaway 1954. Feeding habits of the tomato bug, Cryptopeltis (Engytatus) modestus (Distant) with special reference to the feeding lesion on tomato. Techn. Bull. Univ. Hawaii Coll. Agric. 24 : 5-40
- *Teyrovsky, V. 1952. Water bugs of Jesnik. Sborn. prir. Spolec. Mor. Ostrave (Suppl.) 13 : 1-52
- Uvarov, B. P. 1931. Insects and Climate. Trans. R. ent. Soc. Lond. 79 : 1-247
- Varley, G. C. 1963. The interpretation of change and stability in insect populations. Presidential Address to the Fellows of The Royal Entomological Society of London. 6th Feb. 1963.

- Waterhouse, F. L. 1955. Microclimatological profiles in grass cover in relation to biological problems. Quart. J. R. met. Soc. 81 : 63-71
- Weaver, C. R. 1959. Egg development in Philaenus leucophthalmus. J. econ. Ent. 52(2) :240-242
- Weaver, C. R. and D. R. King 1954. Meadow Spittlebug. Bull. Ohio. agric. Exp. Sta. 741 : 1-99
- Wigglesworth, V. B. 1953. Principles of Insect Physiology. 554 pp. 5th Ed. London
- Wilson, M. C. and R. L. Davis 1953. Varietal tolerance of alfalfa to the meadow spittlebug. J. econ. Ent. 46 : 238-241
- Wilson, H. A. and Dorsey, C. K. 1958. Studies on the composition and microbiology of insect spittle. Ann. ent. Soc. Amer. 50(4) : 399-406

* original not consulted.

APPENDIX I.

APPARATUS.

1. THE SUCTION SAMPLER (Fig. 4).

The suction unit used is a Smith's F 350 centrifugal blower. When operating on a 12 volt supply the unit delivers 165 cubic feet/min. of free air. A 14 cm. metal cylinder was sealed with a rubber collar onto the intake flange of the unit. A "Tufnell" annulus with a rubber washer 1.5 cm. inside the mouth of the cylinder provides a rest for a metal ring to which is attached a nylon collecting bag. A "Tufnell" lid on the cylinder held in place by wing nuts, clamps this ring in place and air-seals the unit except for the intake through a flexible hose (Wolf No. 470), connected to the lid by a rubber connector. The rubber nozzle (No. 1693) supplied with the hose was cut down so as to have a diameter of 3.5 cm. The air speed at this nozzle was estimated to be about 40 m.p.h. - calculated by channeling the air through a Casella mica vane anaemometer (Type T 16300).

2. APPARATUS FOR RECORDING TEMPERATURES AND HUMIDITIES IN VEGETATION

a) THE RECORDING BRIDGE. (FIG. 30).

Because of the need for a very robust instrument capable of measuring temperature and humidity with reasonable accuracy in confined places, a system involving thermistors (manufactured by Standard Telephones and Cables Ltd.), was employed. These are preferable to

FIG. 30 THE THERMISTOR BRIDGE CIRCUIT

THERMISTOR BRIDGE CIRCUIT

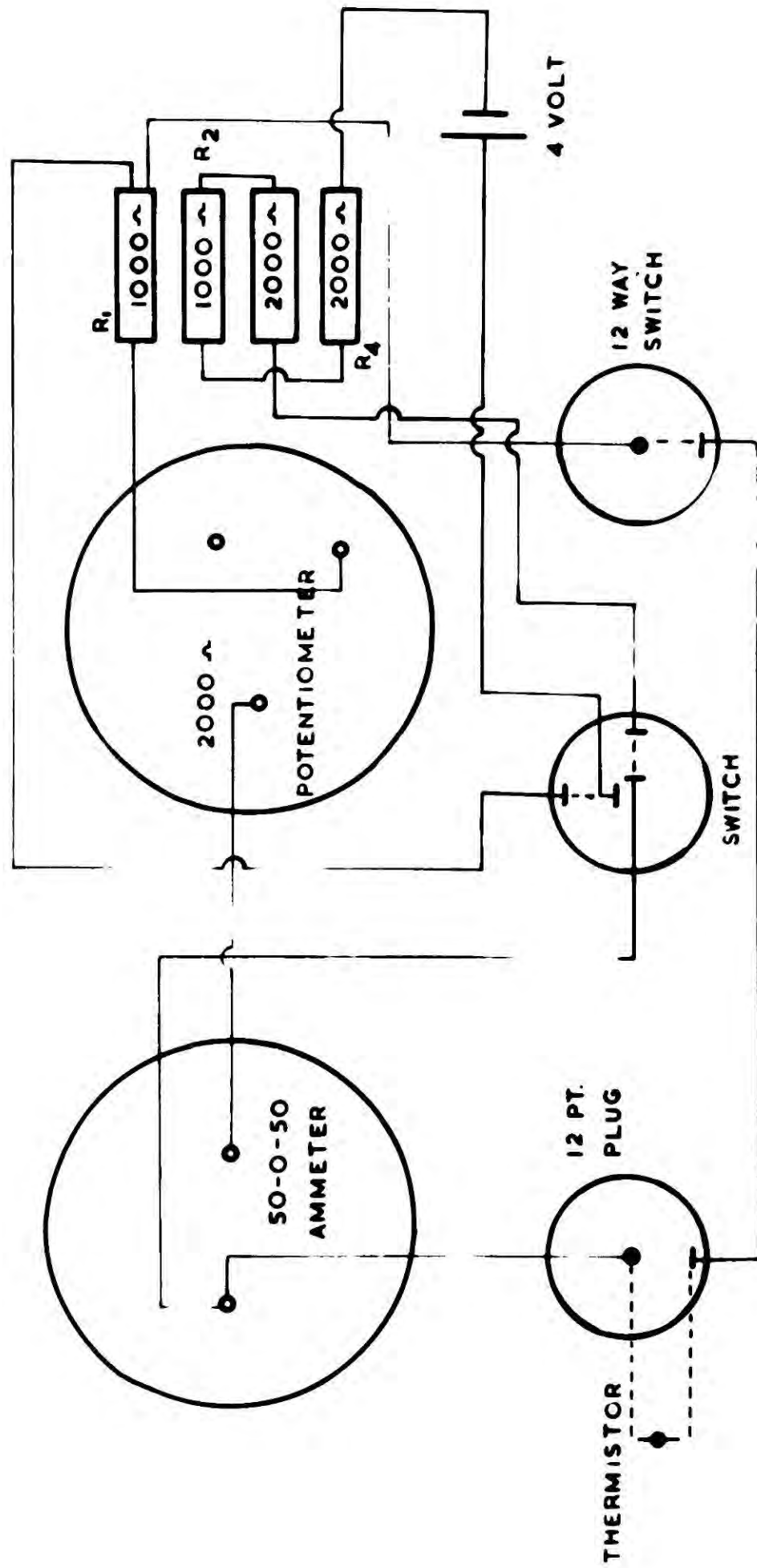

normal thermocouples because no amplification is necessary and so a simple bridge system of recording can be used.

The resistance changes in thermistors consequent upon changes in temperature are large (unlike resistance thermometers), and are easily measured by a bridge system which can be of strong construction suitable for use in the field. Such a bridge was constructed according to the circuit in Figure A1, which allows the use of thermistors with resistances of approximately 2,000 ohms at 20°C (Penman and Long 1949). In such a circuit, the thermistor is the unknown resistance and the bridge is arranged so that all four arms are approximately equal - the condition for maximum sensitivity. Low power dissipation in the thermistor is also a condition for maximum sensitivity, and so a low voltage battery (4 volts) is used in the circuit. The battery is placed in series with a 2,000 ohm resistor (R4) in order to reduce fluctuations as the thermistor resistance changes. Penman and Long found that with a similar arrangement, the bridge current of 0.75 mA was sufficiently small for heating of the element to be negligible.

As the resistance of the thermistor changes with response to the ambient temperature, the balance of the system is restored by changing the values of R_1 and R_2 which are constant in aggregate, but variable in ratio. The movement of the potentiometer needed to affect this restoration (i.e. restoring the micro-ammeter to the null position) is indicated on an arbitrary 360° scale and is a measure of the temperature if suitable calibration is made.

b) THE THERMISTOR TYPES AND THEIR USE

i. Temperature and humidity gradients in vegetation.

Penman and Long (1949) have used two thermistors mounted parallel to each other and about 1.5 cm. apart. One of these is dry and serves as the dry bulb part of a wet and dry bulb hygrometer; the other was kept moist by a wick running from a reservoir mounted adjacent to the two thermistors. The whole unit was thus rather bulky and subject to considerable effects from radiation which necessitated the use of a radiation screen, making the probe even bulkier. A similar probe was constructed for the present study with the idea of lessening its bulk in order to keep the disturbance of the microclimate to a minimum. The sensitive tips of the thermistors were placed as far away as possible from the mounting base and support tower by mounting the F type thermistors on glass rods 20 cm. long separated at their ends by a thin celluloid spacer. Such probe units could then be mounted on a slender brass rod pushed into the ground to serve as a support tower, so that disturbance of the microclimate was minimised. The bases of the probes were octal valve bases which could be plugged into valve mounts from which a multi-core cable ran to the recording apparatus (Plate 5).

Since the device was not to be used for continuous recording, the wick system for the wet bulb was considerably modified to reduce its bulk. A single thread of white cotton was wrapped several times around the constricted neck of the bead and secured to the thermistor

stem by means of a rubber collar. In several tests (in a constant temperature room) this was found to be as efficient as a standard hygrometer wick (Table A1) :

TABLE A1. COMPARISON OF MICRO-HYGROMETER WICKS ON A TYPE F THERMISTOR IN A CONSTANT TEMPERATURE ROOM.

S.T.C. Type F thermistor	Max. depression °C.	
	test 1.	test 2.
1. With muslin sleeve	9.3	-
2. With whirling hygrometer wick	9.0	6.4
3. With cotton wrapping only	9.2	6.3
4. Without a wick (bead moistened directly).	6.2	-

Tests were also made in a constant temperature room to determine the most efficient type of cotton wrapping (Table A2).

TABLE A2. COMPARISON OF TYPES OF COTTON WRAPPING ON A TYPE F THERMISTOR.

	Max. depression °C.
1. Three coils teased out over bead	8.0
2. Four " " " " "	8.0
3. Four coils around neck of bead (i.e. most of bead exposed).	7.3

It is therefore important to have the cotton teased out over the surface of the bead, although the number of coils is not so critical.

Such a wick can easily be moistened with a pipette, and will retain sufficient moisture for several readings to be taken. Any drying out of the wick immediately affects the stability of the bridge microammeter and so is easily detected and remedied.

After these tests had been carried out, a paper by Powell (1936) was seen in which cotton-wrapped thermocouples for micro-psychrometry were described. Here it was shown that very fine psychrometric elements have the advantages (apart from that of small size) of needing little ventilation to give maximum depression of the wet bulb, and of reaching equilibrium temperature in a few seconds. It is possible to use normal wet and dry bulb tables for calculating the relative humidity or saturation deficit.

It has been pointed^{out} (by Bowden (1958)) that errors due to the effects of direct radiation on the thermistor bead can be minimised by painting the sensitive tip of the thermistor white. White cotton was therefore used for the wrapping and both wet and dry thermistors were wrapped in the same way.

ii. Comparison of the Micro-hygrometer with an Assmann Psychrometer.

Tests were made under laboratory conditions to compare the micro-hygrometer with an aspirated Assmann psychrometer which is known to have an error of about one per cent. The micro-hygrometer probe was placed under the wet bulb funnel of the Assmann psychrometer so that both hygrometers were aspirated at approximately the same rate (3 to 4.5 m/sec.) for seven minutes. The readings were then taken at the same time by two observers (Table A3).

TABLE A3. COMPARISON OF THE MICRO-HYGROMETER WITH AN ASSMANN PSYCHROMETER

	Thermistors			Assmann		
	Wet	Dry	R.H. per cent	Wet	Dry	R.H. per cent
TEST 1						
°C	9.6	10.8	86	9.5	10.8	85
TEST 2						
°C	9.4	10.5	87	9.4	10.7	86
TEST 3						
°C	9.6	10.8	86	9.7	10.9	86
TEST 4						
°C	10.6	11.8	86	10.2	11.7	84

iii. Type P thermistor for spittle temperature measurements.

Type F thermistors are too bulky for temperature measurements within cercopid spittle, the spittle being considerably disturbed when they are inserted. Type P thermistors, however, are much smaller and can be inserted into spittle with a minimum of disturbance. The sensitive element consists of a small (maximum diameter 0.5 mm.) glass-glazed bead mounted between two cunife wires emerging from a lead glass probe. These are not designed for use in liquids, but coating with several layers of shellac has been found to have little

effect on the properties of the bead and effectively insulates the lead wires and cunife mounts, thus preventing shorting.

Thermistors of this type were mounted on a probe with a ball and socket device allowing the necessary mobility for easy insertion into spittle at various heights from the ground.

Lake (1956) used similar thermistors (S.T.C. type U) for measuring the temperature profile above bare soil. He found that radiation screens are not necessary with sensitive elements as small as P or U type thermistors.

c) CALIBRATION OF THERMISTORS

Thermistors are resistive elements with a large temperature coefficient. Over the range of temperatures usually encountered in the field ($0 - 35^{\circ}\text{C}$) the temperature/resistance characteristic of F and P type thermistors is almost a straight line. Although this characteristic varies from thermistor to thermistor, the slope of the line is always the same. This means that after an initial accurate calibration has been made and a graph plotted for each thermistor, spot checks are easily made.

The initial accurate calibrations were made by immersing the thermistors in a stirred thermostatically controlled water bath. The temperature was raised in approximately 5°C stages, allowed to stabilise and a reading made for each thermistor on the arbitrary potentiometer scale, after balancing the bridge (i.e. restoring the micro-ammeter to the null position).