

Durham E-Theses

*An investigation into the accuracy of industrial
measurements as practised by the engineering
industries in the Teesside area*

H. C. Ward

How to cite:

Ward, H. C. (1968) An investigation into the accuracy of industrial measurements as practised by the engineering industries in the Teesside area. Masters thesis, Durham University.

Use policy

The full-text may be used and/or reproduced, and given to third parties in any format or medium, without prior permission or charge, for personal research or study, educational, or not-for-profit purposes provided that:

- a full bibliographic reference is made to the original source
- a <https://etheses.durham.ac.uk/id/eprint/10435/> is made to the metadata record in Durham E-Theses
- the full-text is not changed in any way

The full-text must not be sold in any format or medium without the formal permission of the copyright holders.

Please consult the [full Durham E-Theses policy](#) for further details.

THE UNIVERSITY OF DURHAM

"AN INVESTIGATION INTO THE ACCURACY OF INDUSTRIAL
MEASUREMENTS AS PRACTISED BY THE ENGINEERING
INDUSTRIES IN THE TEESSIDE AREA"

by

H. C. WARD

C.G.I.A., C.Eng., F.I.Prod.E., A.M.I.Mech.E., A.M.I.Plant.E.

THESIS SUBMITTED FOR THE DEGREE OF M.Sc.

JULY, 1968

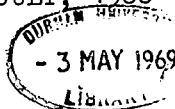

SUMMARY

October, 1966 was the starting date of "Quality and Reliability Year" for British Industry.

The author believes that, after the design stage, the greatest contribution to quality and reliability lies in being able to maintain close dimensional control during the manufacturing process.

This investigation was carried out with the intention of providing the engineering industries in the Teesside area with a realistic picture of the accuracy of engineering measurements carried out in the workshops and inspection departments of the respective individual firms.

The results follow the general pattern set by two similar investigations carried out by the National Physical Laboratory, (N.P.L.), some years ago, but indicate a wider spread of individual errors about the mean size, and correspondingly larger standard deviation.

It also indicates that very few firms in the area possess much more sophisticated equipment than micrometers, dial gauges, and slip gauges, and even these are, in the main, neglected and badly maintained. Optical instruments are almost non-existent.

The operatives estimation of their accuracy of measurement varies from the N.P.L. findings in that a number are more optimistic, but in general there is a wider and more uniform spread of opinion. The firm's assessments of their employees' capabilities also tend to be optimistic, and in some cases suggest

that they do not possess a great deal of knowledge about the ability of their workmen.

Another disturbing aspect is the comparison between standard deviation and the tolerances laid down in B.S. 1916, "Limits and Fits for Engineering". This shows that either the tolerances specified by the British Standard are unrealistic, or that industry in this area has difficulty in working to tolerances closer than I.T.7.

The investigation has shown that working conditions, and the training of operatives in principles of metrology, leave much to be desired, although the latter point appears to be being remedied since the investigation took place.

1.

C O N T E N T S

	Page Number
INTRODUCTION	2
EXPERIMENTAL PROCEDURE	24
RESULTS	
Section (1) INDUSTRIAL MEASUREMENTS OF SIZE ..	32
Section (2) MEASURING EQUIPMENT USED, DEGREE OF ACCURACY AND GENERAL CONDITION	41
Section (3) ESTIMATED ACCURACIES OF MEASUREMENT	50
Section (4) COMPARISON OF STANDARD DEVIATION TO B.S. 1916 "LIMITS & FITS FOR ENGINEERING"	54
Section (5) EQUATION FOR STANDARD DEVIATION	58
Section (6) WORKING CONDITIONS, TRAINING AND EXPERIENCE OF OPERATIVES	61
GENERAL COMMENTS	63
APPENDIX I .. ,. .	67
APPENDIX II	68
ACKNOWLEDGEMENTS	70

INTRODUCTION

It is probably fair comment to say that the main function of the engineering profession is essentially a practical one, involving the application of scientific principles, to practical situations.

On this basis, therefore, one can state that the profession of engineering is completely dependent upon measurements in order to carry out its proper function. This statement can be shown to be true if we imagine the situation where engineers were deprived of all measuring devices. Under these conditions they would be reduced to guesswork and speculation; no matter what theoretical principles and formulae were obtained by the use of mathematics, the derivation of the many constants necessary to apply them could only be obtained by experiment and measurement. I do not think that one can sum up the basis of the process of measurement any more aptly than did Lord Kelvin, almost a hundred years ago, who in the course of a lecture made the following remarks :-

"I often say that when you can measure what you are speaking about and express it in numbers you know something about it; but when you cannot measure it, when you cannot express it in numbers, your knowledge is of a meagre and unsatisfactory nature."

Since measurement is so essential to engineering, it is necessary for the engineer to know and understand the principles and practical limitations of each measuring device which he uses.

Many engineering failures have been caused by engineers placing too much confidence in instrument readings, without first verifying the accuracy of those readings.

Similarly many conclusions are formed on the basis of experimental work carried out in a laboratory, but it should be remembered that a laboratory experiment is no better than the measurements made during the experiment.

One should also appreciate that the limitations of instruments in practical situations, under conditions of vibration, dirt, heat, etc., may vary considerably from those which prevail under laboratory conditions.

Fundamental Principles of Measurement

This project is concerned exclusively with measurements. It is therefore considered right and proper that some space should be devoted to elaboration of the term "measurement".

A measurement may be defined as an "opinion" which has been formed by one or more observers about the relative size or intensity of something after observing a change in an instrument reading, or observing a direct change in the object itself. For the measurement to be accepted as being successful it is imperative that two different observers shall form the same opinion. A difference of opinion between observers as to the size of a change is one of the sources of error in experimental work.

Measurements may be divided into the following classifications:- primary, secondary and tertiary measurements.

A primary measurement is one that can be made by direct observation with no translation of the measured property into length. Examples of primary measurements are the matching of two lengths, such as the determination of the length of a bar with a ruler, and the matching of two colours.

It has been found that the most uniform agreement between different observers as to the size of measurement will be obtained when "sight" is used as the sense for observation. It is further agreed that better results are obtained when the measurement is transmitted in the form of a length, or a change in length. Measurement transmitted in the form of colour variation, light intensity variation, or by using any of the other senses, invariably results in rather poor agreement between different observers. For this reason most measurements are transmitted to the observer's brain in the form of a length change, usually by means of a pointer moving over a scale marked with arbitrary units of measurement at length intervals on the scale.

This leads to the conclusion that length measurements can be in two classifications; a primary measurement of the length of an object itself, and the travel of some indicator over a calibrated scale where the length units represent changes of almost any property. This latter type will be one portion of a typical secondary measurement.

Secondary measurements involve one translation. If the measured quantity is not directly observable, (e.g. gas pressure),

it is possible to utilise:-

- (1) a device which will translate pressure changes into length changes, and
- (2) a length scale which is calibrated into length units equivalent to known changes of pressure.

Thus in the case of a pressure gauge the primary signal (pressure) is transmitted to a transducer or translator, and the secondary signal (length) will then be transmitted to the observers eye.

Tertiary measurements are those involving two translations. A typical example is the measurement of the speed of change in position of a machine tool table by means of an electrical transducer. In this case movement of the table (the primary signal) is transmitted to the transducer which generates a voltage proportional to table speed. The first translation is therefore speed to voltage. The voltage, in turn, is transmitted by a pair of wires to a meter, i.e. a pointer moving over a scale. The second translation being voltage to length. This may be shown diagrammatically as follows:-

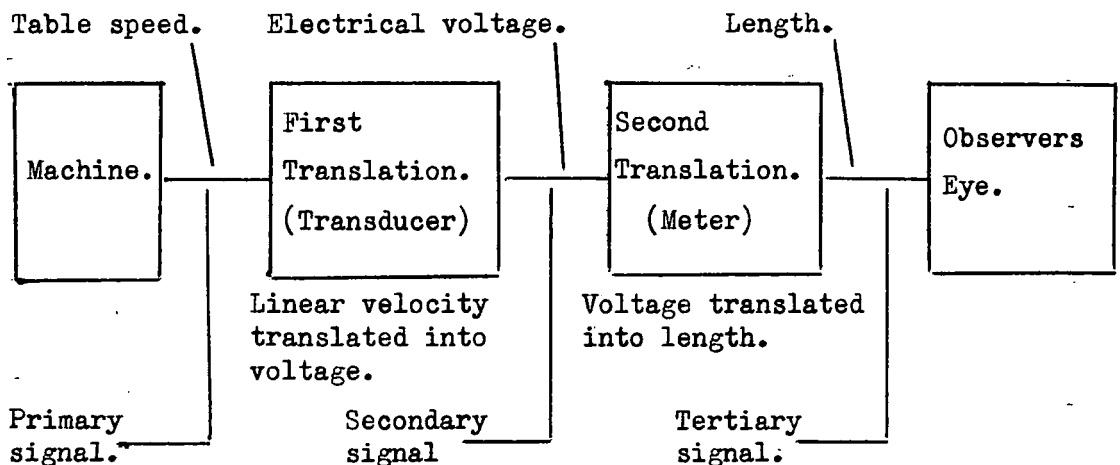

It will be obvious that there is more possibility of errors occurring in a tertiary system than in a secondary system.

However, if the secondary signal is electrical then there are two advantages which may outweigh the disadvantage of two translations:-

- (1) an electrical signal is easily transmitted over long distances, giving remote indication, and
- (2) it is possible to amplify electrical signals many times with very little distortion.

The subject of errors in measurement will be discussed in some length at a later stage in this report. However, it is appropriate at this point to introduce the topic briefly.

In general, errors may be classified into four types:-

- (1) Observation errors, made by the observer when reading a scale and pointer, or measuring a length.
- (2) Translation errors, present when an instrument does not translate with complete fidelity.
- (3) Signal transmission errors, such as a drop in voltage along the wires between transducer and meter.
- (4) Instrument location errors, such as placing a thermometer in direct sunlight.

Observation errors may be pure carelessness on the part of the observer, may be due to parallax, improper lighting, vibration etc. Translation errors will always be present to some extent but may be compensated for by calibration of the measuring

instruments. Signal transmission errors may likewise be compensated for by calibration of the instrument system, while correct location of the instrument will do much to eliminate or reduce errors caused by draughts, sunlight, etc.

Historical Review of the Measurement of Length

When one considers the importance of being able to carry out accurate measurements, and in particular measurements of length, in this present day and age it is rather surprising to find that determined efforts to provide reliable standards and measuring instruments did not really get under way until the nineteenth century. A rather interesting point is made by Heinrich Harrar in his book "Seven Years in Tibet". Commenting on conditions of life in Tibet as late as the 1940's, he writes: "As the metric system is here totally unknown, people measure by the length of arm, which approximately corresponds to our old ell!"

Very little information appears to be available regarding the units of length used in past times. However it would appear that ancient units of measurement are of three kinds:-

- (1) The units based on a definition.
- (2) The units represented by a concrete and well defined object.
- (3) The units which refer to standards specially designed for this purpose.

To my knowledge the oldest unit of length belongs to the first category and originated in China during the reign of Emperor Hoang-lin about 3000 B.C. This unit was based on a kind

of tuning flute whose length was equal to 90 corn grains placed end to end. This length was divided into nine equal parts, each part being called an "inch".

An agricultural product has frequently been used as the basis of measuring magnitude. In Bohemia it was decreed that four grains of barley corn placed side by side are equal to one transversal finger, and ten transversal fingers are equal to a span; in England, Edward I ordained that "three barley corns, dry and round, make an inch".

The use of the length of limbs, or parts of limbs was also a popular method of specifying measurements of length in early Egyptian and Sumerian times. The main unit used was the "cubit", which was based on the length of the forearm from the elbow to the tip of the middle finger.

Smaller units were based on the lengths of parts of the hand and foot. The distance between one finger and the next, taken at the base of the fingers, was known as one digit, and four digits = one palm (approximately three modern inches).

However, these natural units suffered from the disadvantage that they varied from person to person, and as civilisation developed attempts were made to standardise their lengths. The oldest standards of this type were known as standard cubit rods, sub-divided into smaller units. It is probable that one of the oldest of these standards is the "Egyptian Grey Basalt Cubit" which dates from the year 2600 B.C. In comparison with present day systems its length is 520 mm and is divided into seven parts

each part being one palm.

A great many other standards, dating from different epochs, have been found which vary considerably in their dimensions. Many of these originate in Egypt, but there is evidence to show that many others can be attributed to the Sumerians, Assyrians, Greeks, Romans, Chinese and Indians. A comparison of some of these old master lengths is shown below.

OLD MASTER LENGTHS

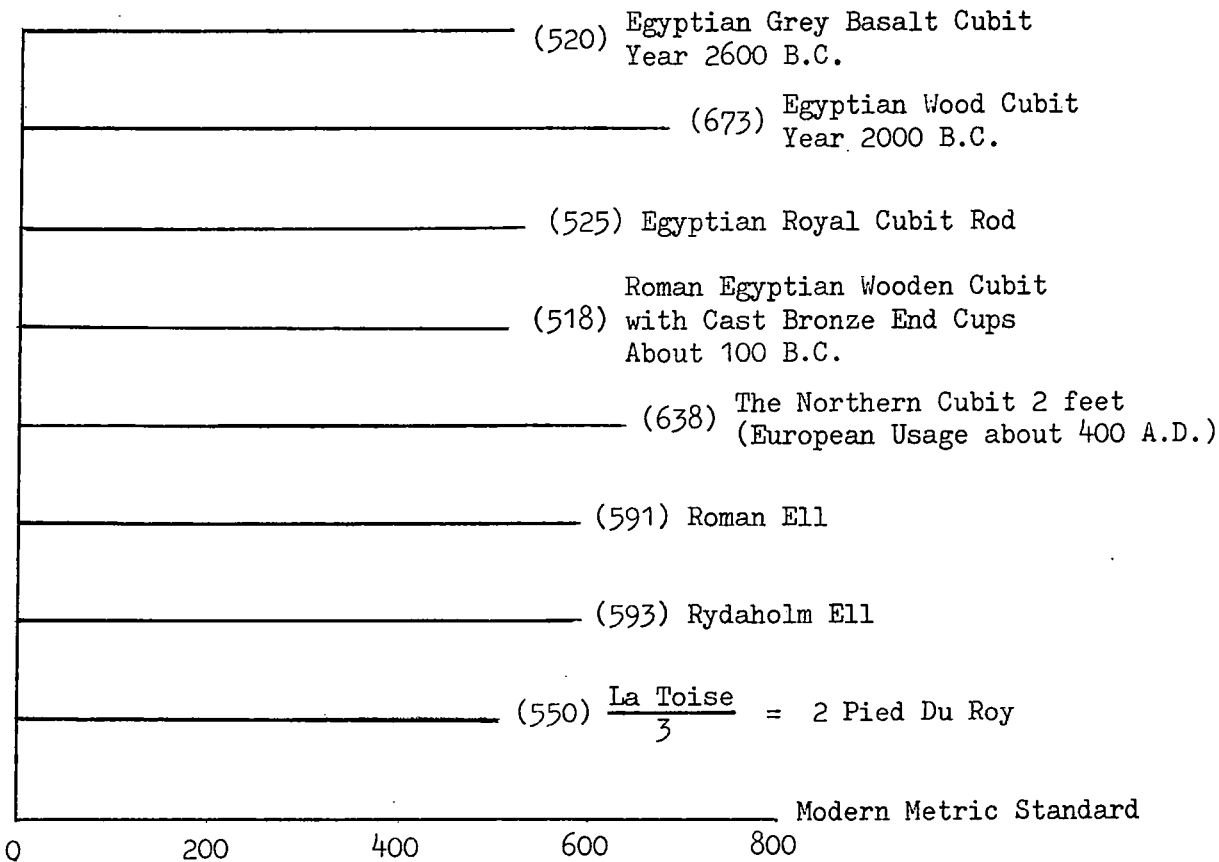

Early English units were, like many other civilisations, based on the length of human limbs. Unfortunately different districts based their units on some local personage, therefore the units would possess different values in the various parts of the country.

It would appear that the first material standard used in this country was the "Ulna", introduced by Edward I in 1305 A.D. This was an iron bar and its length was designated as "the standard yard". The legal definition given was "that three grains of barley, dry and round, make an inch, twelve inches make a foot, three feet make one ulna".

This standard was an end standard, i.e. the length was specified as the distance between the parallel end faces, as were the later standards introduced by Henry VII (1497) and Elizabeth I (1598).

The first line standard was introduced by John Bird in 1760, and was similar to the present standard in that it consisted of a bronze bar in which were set two gold plugs. The length being defined as the distance between two fine dots, one on each plug. In point of fact this standard was only legalised in 1824, and was destroyed by fire ten years later. This led to the construction of the true line standard, legally adopted in 1856, then known as the Imperial Standard Yard, and now known as the United Kingdom Primary Standard of the Yard.

The Metric Standard

The French also suffered from a chaotic situation arising from the use of a number of different standards of length. However, it was not until 1760 that any real attempt at rationalisation was made. At this time Talleyrand made his unique proposal that there should be an examination into the possibility of deriving a universal measuring system which would be acceptable to all people of the world. He also suggested that the new unit should be based on the length of a pendulum beating the seconds. Examination of this proposal was carried out by the "Academie des Sciences", who unfortunately decided that the unit of length should be related to some portion of the earth's surface. The practical standard arising from this was in the form of a platinum end standard called the "metre des archives" and was adopted in 1799.

The reasons for stating that the decision taken was unfortunate arise from :-

- (1) in practise the geographical definition was found to be inconvenient, and
- (2) had the decision been taken to adopt Talleyrand's suggestion, i.e. the length of a pendulum beating seconds, as the standard, then it was likely that the proposal would have been accepted by Britain and the United States, thus creating an international standard and sparing us from the misery of nearly two hundred years of confusion in units of length.

Following an international commission in 1870 an international standard of length based on the metre des archives was created. This was a line standard of platinum-iridium and was adopted at the international conference of 1889.

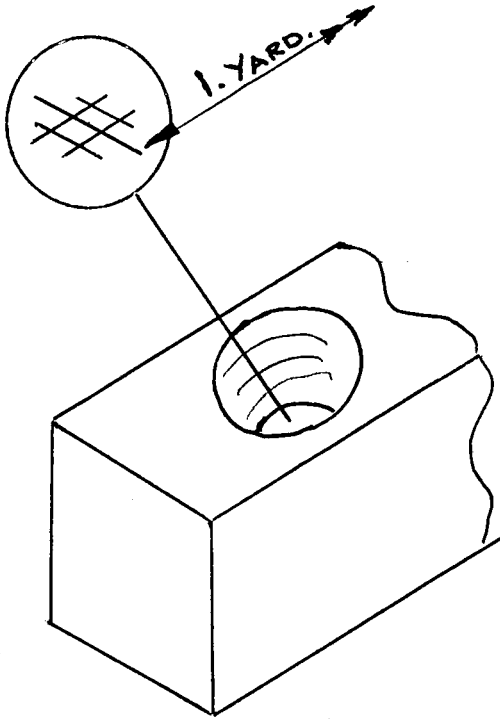

Imperial Standard Yard.

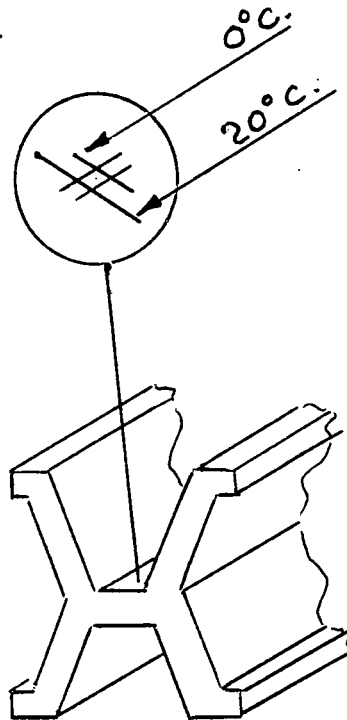

International Prototype Metre.

American Standards

The United States were also experiencing trouble in the setting up of a primary length standard. In 1832 an unofficial line standard defined the yard as "the distance between the 27th and 63rd inch graduation on a brass scale made by Edward Troughton".

In 1857 it was supplanted by two copies of the Imperial Standard Yard, and in 1893 an order was issued which defined the U.S. yard in terms of the metre.

International Developments

The use of the wavelength of light as a natural standard of length was first suggested in 1829 by the French Physicist, J. Babinet.

However, it was not until 1892-93 that Michelson and Benoit, at the International Bureau of Weights and Measures, made the first direct measurement of the metre in terms of the wavelength of the Cadmium red radiation.

Several measurements have been made since, in various parts of the world, with remarkable consistency in their results.

In 1960 the General Conference of the International Committee of Weights and Measures adopted a suggestion that the metre should be re-defined as "1,650,763.73 times the vacuum wavelength of the orange-red radiation of krypton 86."

Prior to this it had been shown that the Imperial Standard Yard bar was unstable, and was in fact shrinking by about 1 micro-inch per year. As a result, for all scientific and technological purposes,

the conversion factor relating the yard and metric systems was frozen at 1 metre = 39.370147 inches, thus for all practical purposes the metre has been the standard since that date.

There was also a serious difference between the British and U.S. yard. The U.S. yard being based on the metre in the ratio of 36:39.370000 as against the British ratio of 36:39.370147. A difference of 3.7 micro inches. In July, 1959 standardising laboratories of both countries agreed to work on a new international value of the yard, 0.9144 metre.

It is now unlikely that further major changes in the definition of length standards will be introduced for some considerable time, and we can therefore expect international interchangeability to become a commonplace engineering occurrence.

Instruments for the Measurement of Length

If a length can be seen by an observer, it can be measured directly. In this connection we speak of a length, or a change in length, as the distance between two reference points. The smallest length change which can be seen by the unaided eye is approximately $\frac{1}{200}$ inch, assuming perfect eyesight, good lighting and the right distance from the object under observation.

However, it would probably be fairer to say a change of length of $\frac{1}{100}$ inch is a more reasonable figure from the practical point of view.

Therefore in order to make length measurements to an accuracy better than the sensitivity of the human eye ($\pm .005$ inch),

it will be necessary to amplify the length changes before they are observed by the eye.

The amplification may be done by several methods, e.g. optical magnification, simple magnifying glass or lens system, a vernier scale, a lever system or screw thread. More complex systems may involve making a tertiary length measurement by means of a strain gauge of the electrical resistance type. There are so many different types of length measuring devices available that no attempt will be made to describe them. What is probably more relevant is short review of the development of precision measuring methods.

There were few developments of this kind prior to the Eighteenth century, although Pierre Vernier (1580 - 1673) invented the device bearing his name, and in 1638 Gascoigne produced the first micrometer. However both of these had severe limitations due to the inability to produce accurate scales and screw threads. Bird was reputed to be using 90 inch and 23 inch scales fitted with verniers, which were readable to 0.001 inch, in 1750. However, their use must have been severely restricted for it is often quoted that in 1760 the English engineer Richard Reynolds made great propaganda of the fact that he produced a 28 inch diameter cylinder "to such a degree of roundness as to make the longest way across less than the thickness of my little finger greater than the shortest way; which was a matter of much pleasure to me, as being the best we so far had any knowledge of."

The invention of the linear ruling engine by Ramsden in 1775 made possible the marking of accurate scales quickly and this led to the introduction of the vernier for general workshop use.

A major advance in the production of micrometers was made by Watt in 1772. This instrument had a screw pitch of about 19 turns per inch, and there were 51 divisions on the fractional dial, each division representing 0.001 inch.

In 1805 Maudslay used his superior screw-cutting lathe to produce a bench micrometer with flat parallel ends and a 100 t.p.i. micrometer screw. This instrument could be read to the nearest 0.0001 inch.

Probably due to the nature of the work being carried out at that time (individual hand fitting of engineering mechanisms), little advantage was taken of these developments. In fact a common north country expression implied that the required fit between a shaft and bearing was reached when the fitter could just place the peak of his cloth cap between the two parts.

With the need for interchangeability becoming more urgent, around the mid-nineteenth century, Eli Whitney introduced his system of using a master gauge for each critical dimension. This unfortunately restricted interchangeability between parts solely to those produced in the factory holding the master gauge. To overcome this difficulty Joseph Whitworth introduced a system of end bars, with flat parallel faces. These were blocks extending from 1 in. to 12 in. by 1 in. increments, and 12 in. to 36 in. in 6 in. increments. These were used in conjunction with a measuring

machine to compare the relative sizes of the workpiece and end standard. Whitworth also introduced standard plug and ring gauges of nominal size.

This was a progressive period for measuring instruments development. In France, Palmer produced the forerunner of the modern hand micrometer, a more improved version being manufactured by the American firm of Browne and Sharp in 1885. This firm also introduced the vernier calliper in 1851.

Americans also originated the manufacture of dial gauges about 1890, credit being given to the watch-making industry for the basic idea.

In 1896 C. E. Johansson set up a business to manufacture sets of "slip gauges". These blocks were invaluable for the modern mass production of interchangeable parts, although it was not until the outbreak of World War I that they were fully appreciated. Due to the difficulties in importation the N.P.L. developed a method of manufacturing slips to the accuracy required thus leading to their manufacture in this country.

The N.P.L. also developed a set of length bars made in nominal sizes up to 36 in.

The use of end gauges in industry brought with it another difficulty. That of quick, efficient and accurate means of comparing the workpiece and slip gauges, and also the comparison of slip gauge to standards.

Considerable effort was now made in this direction, and probably the most important contributions were made by E. M. Eden and F. H. Rolt, who produced the now well known Eden-Rolt millionth comparator, and A. J. C. Brookes, who developed the Brookes level comparator.

Although the availability of modern workshop instruments capable of measuring length differences of as little as ten millionths of an inch is now taken for granted, it should be appreciated that the work which made these instruments possible was first started by these pioneers only fifty years ago.

The Accuracy of Measurements of Length

In view of the many different types of measuring instruments, along with their varying degrees of precision, one would expect that there would be no problems in measuring accurately the length of commonplace engineering components.

It is therefore surprising to find the number of times that two mating parts, made in the same factory, do not assemble together with the degree of fit which the designer intended. Small wonder then if mating components made in different factories are even worse.

What then are the possible causes of errors or variations in measurements of length?

Firstly, it should be appreciated that every measuring instrument possesses inherent errors which are independent of the conditions under which the measurement is being made, and of the

workpiece being measured, and also of the operator carrying out the measurement. This inherent error may be made up of two components, one a systematic error, the other a random error.

A systematic error is one which is a permanent feature of the instrument and will always show up with the same value at a particular point during the operation of the instrument. A typical example of this is an error of pitch along the length of a micrometer screw. Such errors can be measured and a curve of errors drawn, or alternatively a calibration chart prepared, for each instrument. Correction can therefore be applied as necessary.

Random errors however are not consistent in their occurrence and may be due to the presence of backlash in gears, friction in linkages and so on. In order to reduce these to a minimum it is necessary to take a number of readings of the same measurement, under the same conditions, and preferably by a number of persons. These results when plotted will usually be in the form of a Normal Distribution curve*. It is therefore possible to calculate the standard deviation and to assess the percentage of readings within certain limits about the mean size.

The error at any point over the range of the measuring instrument is determined by combining the systematic and random errors. The true size at any one point on a component is the size corresponding to the mean value of a number of readings on the instrument at that point, correction being made for the systematic error at that position.

* See Appendix I

In many cases it is not possible to use a correction curve or to carry out a large number of measurements. Under these conditions it is perhaps better to express the size measurements to within a certain limit of accuracy. Leinweber (Germany)⁽¹⁾ suggests a method of determining the measuring uncertainty which may be associated with any type of measurement.

A second point to consider is the influence of workshop conditions on the accuracy of measurement. In general these may be classified as follows:

Errors due to temperature,

Observational errors,

Influence of workpiece.

Although it is laid down, by international agreement, that the true size of a piece is the size obtained at the standard temperature of 20°C it is not strictly necessary for all measurements to be carried out at this temperature. The main conditions are that, when the workpiece and standard are of the same material, they are both at the same temperature. If they are of different materials then it is necessary to know their respective coefficients of expansion and to calculate the appropriate correction.

Temperature errors usually occur in one of the following ways:-

- (a) not allowing the workpiece to cool down after a machining operation,
- (b) measuring instruments left lying in strong sunlight or on top of heating appliances,
- (c) the workpiece being situated in a cold draught of air, possibly producing deformation,

- (d) excessive handling of either workpiece or standard.

Observational errors usually fall under one of the headings below:-

- (a) due to parallax,
- (b) scale divisions too small,
- (c) scale graduation lines and/or pointer too thick,
- (d) incorrect interpolation of the position of the pointer in relation to adjacent scale graduation line,
- (e) in-correct sense of feel,
- (f) downright carelessness.

In general good instrument design can do much to eliminate errors due to (a); (b), (c), and (e), while correct training and guidance can do much to reduce errors due to (d) and (f).

Under the third classification come errors due to deformation of the workpiece caused by the measuring pressure of the instrument used.

Two types of deformation are possible, general and local. General deformation may be produced when measuring thin called tubes with a vernier calliper. The amount of deformation will depend on the sense of feel of individual observers.

Local deformation occurs at the point of contact with the measuring tip or stylus. The amount of deformation in this case varies with the measuring force, the shape of the measuring face, and the relative form of the workpiece and setting standard.

Nickols and Oakley⁽²⁾ have carried out investigations at the N.P.L. on this source of error and recommendations governing size of radii of comparator anvils and the measuring force are incorporated in Part 2. of the I.S.O. System of Limits and Fits.

Looking back over the many investigations which have been directed towards increasing the accuracy of measurements of length it is noticeable that most of this work has been carried by individual firms dealing with specific problems, typical examples being the work carried out by T. P. Jolly for the English Electric Company and Professor N. N. Sawin for the Skoda Works, both dealing with measurement in the heavy engineering field.

A further noticeable fact is that most of this work was concerned only with, "Which measuring method or instrument is most accurate?", the quality of the observer being taken for granted.

The proposed extension, in 1952, of the system of limits and fits laid down in I.S.A. Bulletin 25, provided a first opportunity for all member countries to carry out work on a national scale to determine:-

- (1) the accuracy of measurement in the range 100 to 2030 mm.
- and
- (2) to note the methods of measurement commonly used, and to establish the best method for a particular size.

About five years later it was agreed that the part of I.S.A. Bulletin 25 covering the size range 0.5 mm to 125 mm should be

revised and accordingly member countries were asked to carry out similar investigations dealing with this size range.

In this country the work of both investigations was carried out by Mr. P. W. Harrison of the Standards Division, N.P.L. Two reports were published ⁽³⁾⁽⁴⁾ which in general set out the facts which were obtained but unfortunately did not, in the writer's opinion, state quite bluntly that for the most part the accuracy of measurements made in the engineering firms left much to be desired.

Following these investigations the N.P.L., in co-operation with the Institutions of Mechanical, Electrical and Production Engineers, arranged a two day conference in April, 1962 to discuss the problems of "The Accuracy of Industrial Measurement of Length and Diameter".

This was very well attended and the general theme was that much improvement was needed. Unfortunately, like many other good intentions, though some initial efforts were made to remedy the situation, certain areas of industry showed little interest in pursuing the topic, and in fact some firms never bothered to find out just how they were placed in the "accuracy league".

The writer believes that a similar state of affairs existed within the engineering industries situated in the Teesside area, and accordingly this project was started with the intention of showing the accuracy of engineering measurements of length in the area, and to make recommendations as to how improvements could be made, if this was found to be desirable.

EXPERIMENTAL PROCEDURE

The procedure adopted for this investigation was very similar to that used by the N.P.L. The main difference, however, is that whereas the N.P.L. investigations stopped after assessing the degree of accuracy which was being attained by industry, this investigation went further by attempting to analyse the reasons for the inaccuracies which were implied by the results obtained.

A set of test pieces was prepared to cover a suitable range of sizes, which could be submitted for measurement to the participating firms. In view of the wide diversity of engineering which was covered by the firms accepting the invitation to take part, it was felt that neither of the two ranges prepared by the N.P.L. was truly representative of typical work dimensions for this area. Accordingly the following nominal size of test pieces were selected.

External diameters: 0.04, 0.15, 0.4, 1.0, 2.5, 5.0, 10.0, 15.0 inches

Internal diameters: 0.15, 0.4, 1.0, 2.5, 5.0, 8.0, 13.0, inches

In view of the large amount of heavy engineering which is practiced in this area it was desirable that larger sizes up to approximately 75 inches should have been included. However, this was decided against for the following reasons,

- (1) the difficulty in getting these manufactured,
- (2) the difficulty of transporting them to the various firms, and
- (3) the difficulty in establishing their precise size using the existing equipment in the College.

Nevertheless it was felt that the above range of sizes provided a fair compromise between the extremities of work size produced by the different firms taking part.

Test pieces in the size range 0.04 in to 5.0 in external and 0.15 in to 5.0 in internal diameters were loaned to the College by the N.P.L., and consisted of test pieces from sets 1 and 3 used in their second investigation. Test pieces of 10.0 in external, combined with 8.0 in internal, and 15.0 in external combined with 13.0 in internal diameters, were manufactured locally.

In order to reduce the time required to complete the investigation two sets of test pieces were obtained.

All the test pieces were checked for degree of surface finish on a Model 3 Talysurf and Table 1. shows the values recorded.

TABLE 1. TYPICAL VALUES OF SURFACE FINISH

External Diameter (inches)	Surface finish in. C.L.A. micro-inches C.L.A.	Internal Diameter (inches)	Surface finish in. C.L.A. micro-inches C.L.A.
0.04	3	0.15	.
0.15	4	0.4	3
0.4	5	1.0	2
1.0	4	2.5	12
2.5	7	5.0	7
5.0	4	8.0	30
10.0	40	13.0	40
15.0	20		

All the test pieces were measured initially in the College Metrology Laboratory. Particular care was taken over this part of the investigation, it being realised that the whole success of the project depended upon the accuracy to which these measurements were made. The main source of worry was that of temperature control, the room not being air conditioned nor fitted with thermostatic control. However, from records which have been kept it was noticed that during the early spring the room temperature could be maintained at $68^{\circ}\text{F} \pm 2^{\circ}$ and that the rate of change of temperature did not exceed 1°F in a period of four hours. This was accepted as being satisfactory provided that the following conditions were also observed.

- (1) That all pieces would be taken into the laboratory at least twenty-four hours before any measurement was taken.
- (2) That all pieces would be correctly positioned on the measuring instrument and then allowed to stand for fifteen minutes before a first reading was taken. Two more readings were to be taken at further fifteen minute intervals, and the mean value of the three readings would be taken as the measured size.

Four instruments were selected for carrying out these initial measurements;

Societe Genevoise M.U.L. 300 Gauge Measuring Machine,

Societe Genevoise M.U. 214B Universal Measuring Machine,

O.M.T. Horizontal Comparator,

Sigma Superset Electrical Comparator.

Prior to measuring the pieces, tests were made to determine the degree of accuracy and repeatability which could be obtained under these conditions. Measurements were made on each of the above instruments using a C.E.J. 'Reference' set of slip gauges and a Matrix 'Reference' set of length bars, both of which had been calibrated at the N.P.L.

During these tests it was discovered that the O.M.T. instrument had a sticking plunger, and therefore this instrument was not used in the subsequent measurements. However, from the remaining three instruments each dimension could be checked by two separate methods thus giving confirmation of size. The exception to this was the very small internal diameter, which could only be measured on the Universal Measuring Machine. Some attempt was made to check the fit of cylindrical plugs into this diameter, and subsequently measure the plug. Unfortunately the human element crept into this to such an extent that three separate observers had variations greater than 0.001 between them.

Some out of roundness of the pieces was discovered at this stage and to reduce the possibility of errors from this source each piece was clearly marked at the diameter over which the measurements were to be taken.

During the initial measuring stage it was found that the locally manufactured workpieces, particularly the internal diameters, were appreciably tapered. In order not to delay the investigation it was at first decided that these pieces should be omitted completely. However, on second thoughts they were

distributed in the normal manner, instructions being given that all workpieces were to be measured at the mid-point of the machined surfaces. Some variation in the measurement of these pieces was inevitable but it was considered worthwhile to include these pieces if only to find the number of observers who would discover, and comment on, the amount of taper present.

The pieces were subsequently re-measured when half of the participating firms had carried out their observations, and again at the completion of all observations.

The estimated accuracy of the College measurements and the subsequent variation from the initial readings are shown in Table 2.

All participating firms were asked to take care in the handling of the work pieces and to avoid damage. In general this was very well done, but some local damage was observed on the larger test pieces, this no doubt accounting for the comparatively small variation in size on the second re-measurement. On a few occasions the test pieces were returned without a protective coat of oil.

Invitations to participate in the investigation were sent to approximately fifty firms. From these there were thirty-one acceptances and nine polite refusals. The remainder were obviously not interested.

All aspects of engineering received consideration when sending out the invitations, and the following list gives some

TABLE 2. ESTIMATED ACCURACY OF CONSTANTINE COLLEGE
MEASUREMENTS AND VARIATION IN MEASURED SIZES

External Diameter	Estimated accuracy of C.C.T. Measurements	Variation from measured sizes			
		First re-measurement		Second re-measurement	
		Set 1.	Set 3.	Set 1.	Set 3.
0.04	0.000 02	0.000 00	0.000 00	0.000 00	0.000 00
0.15	0.000 02	+0.000 01	+0.000 01	0.000 00	0.000 00
0.4	0.000 02	0.000 00	0.000 00	0.000 00	0.000 00
1.0	0.000 02	0.000 00	0.000 00	-0.000 04	-0.000 03
2.5	0.000 02	0.000 00	0.000 00	0.000 00	0.000 00
5.0	0.000 03	-0.000 04	-0.000 02	0.000 00	0.000 00
10.0	0.000 06	0.000 00	-0.000 01	-0.000 09	-0.000 06
15.0	0.000 08	-0.000 01	-0.000 01	-0.000 09	-0.000 04
Internal Diameter		Set 1.	Set 3.	Set 1.	Set 3.
0.15	0.000 04	0.000 00	0.000 00	0.000 00	0.000 00
0.4	0.000 02	-0.000 01	0.000 00	0.000 02	0.000 02
1.0	0.000 02	-0.000 02	0.000 00	0.000 01	0.000 01
2.5	0.000 02	-0.000 02	0.000 01	0.000 01	0.000 03
5.0	0.000 04	-0.000 01	0.000 02	-0.000 03	0.000 04
8.0	0.000 06	-0.000 02	0.000 01	0.000 05	0.000 08
13.0	0.000 08	0.000 02	0.000 02	0.000 08	0.000 07

idea of the diverse interests of the actual participants.

Chemical and Steel plant	Bearings
Marine Engineering	Car accessories
Machine tools	Electrical equipment
Gear manufacture	General engineering
Instruments	Heavy engineering
Turbines	

As with the N.P.L. investigations the information sought from the firms was:

- (1) The external and internal sizes of the work pieces supplied, Measurements to be made at the positions specified, and under their ordinary workshop conditions, by at least one machinist, and preferably by several.
- (2) Also, if possible, the external and internal diameters as obtained by one or more inspectors, under their usual conditions for inspection.
- (3) A description of the method used, and the make, type, and magnification of the measuring equipment used for each measurement.
- (4) The accuracy to which they would normally be prepared to quote their measurement of such work pieces.

Analysis of the results obtained showed that the problem of inaccuracy of measurement is far greater than was expected. It was therefore felt that a further study should be made to attempt to discover the source of these errors and thus show how they could be eliminated or reduced.

The firms who had participated were therefore approached with a request that facilities be given for the following programme to be carried out.

- (1) A check to be carried out on a representative sample of standards and inspection and shop floor measuring equipment. The checks to be carried out in the College laboratory and to the standard prescribed in the relevant British Standard Specification.
- (2) To obtain details of the training and experience of those who made the measurements; specific training in measurement being specially noted.
- (3) To obtain details of the conditions under which the measurements were taken, e.g. shop temperature, lighting, cleanliness etc.
- (4) To obtain the firms assessment of the estimated accuracy of each man's ability, as opposed to the man's own opinion.

Some twenty firms signified their willingness to co-operate in this further investigation. As this included a fair representation of the differing types of firm who had taken part in the original survey it was felt that this was sufficient to justify the carrying out of this programme, and that the results would give some guidance as to the source of errors.

RESULTSSECTION 1 Industrial Measurements of Size

Following the pattern set by the N.P.L. investigations all the results have been treated as confidential and are identified in this report by code letters.

On completion of the actual measuring of the test pieces all the results were tabulated and fed into an I.B.M. 1620 computer which was programmed to produce the following computations:-

- a) the difference between the industrial measurements and those made in the College,
- b) the algebraic mean error of the observations for each size of test piece,
- c) the value of the standard deviation about the mean line for each diameter.

From these results graphs were plotted (Fig. 1.) showing the differences in size, each letter denoting a firm, and the numerical suffixes the individual observers in each firm. All observations were plotted on these graphs in order that:-

- a) each observer can assess his own performance, and
- b) the collective efforts of each firm can be assessed.

In general these charts show similar properties to those derived in the N.P.L. investigations i.e. that external measurements tend to be better than internal measurements, although it is noticeable that on the larger sizes of test pieces this difference is almost negligible.

Examination of the results showed a number of errors so large as to suggest arithmetical errors. For this reason the computer programme for algebraic mean error and standard deviation was modified, to eliminate readings with,

- (a) errors above 0.007 inch
- (b) errors above 0.002 inch
- (c) errors above 0.001 inch
- (d) errors above 0.0007 inch
- (e) errors above 0.0005 inch

The algebraic mean errors have been plotted on graphs (Fig. 2) and these show similar trends to those obtained by the N.P.L. In order to gain a fair comparison the graphs which eliminate errors greater than 0.001 inch were superimposed on the same graphs from the N.P.L. report. These show clearly that whilst the inspection results are quite favourable, there is room for improvement on the workshop side.

The actual number of observations which were used to compile these graphs are given in Table 3 under the column headed "Code letter B", and tend to confirm the views expressed above.

It is also worth noting that in the N.P.L. report it is stated that the inclusion of errors greater than 0.001 inch would, in the worst case, have changed the mean value by 0.00009 inch.

Table 4 gives the respective mean values for all observations in this investigation and those with errors less than 0.001 inch. It can be seen that there is a radical difference between them, in most cases far more than the 0.00009 inch quoted in the N.P.L. report, but elimination of the obvious arithmetical errors produces results similar to the N.P.L. results.

Sizes	Mean Error All Results		Mean Error for observations in error by less than 0.001 inch	
	Inspection	Workshop	Inspection	Workshop
0.04	0.000473	0.0109751	0.000473	0.0001078
0.15	External	0.0307771	-0.0029095	0.0000072
	Internal	0.0001005	-0.0003263	-0.0000125
0.4	External	-0.0000292	0.0009485	0.0000238
	Internal	0.0001397	0.0012734	0.0000817
1.0	External	0.000009	0.0016132	0.0000964
	Internal	0.0000971	-0.0001592	0.0001278
2.5	External	-0.0004506	0.0016435	0.0001915
	Internal	0.0006312	0.0010518	0.0000687
5.0	External	-0.0032653	0.0036413	0.0001307
	Internal	0.0000897	0.0043153	0.0003024
8.0	Internal	-0.0018092	-0.000685	0.0001808
10.0	External	-0.000788	0.0031379	-0.0000211
13.0	Internal	-0.0003855	0.0502285	-0.0001367
15.0	External	-0.0073658	-0.0112360	0.0000136

TABLE 4.

Both of the previous N.P.L. investigations have shown that the distribution of errors about the algebraic mean may be considered to conform approximately to a normal Gaussian distribution and that it would be legitimate to calculate values of standard deviation on this basis. (See Appendix I)

Accordingly values of standard deviation have been calculated in a similar manner to that used by N.P.L. and these have been plotted and compared with the values derived by the N.P.L. Table 3 shows the number of observations used for each calculation. In the column "Code letter A" it has been assumed that all observations obtained in the N.P.L. investigations were used. The few extremely large arithmetical errors were taken out of the C.C.T. results in order to give a more balanced comparison at this stage. For all other graphs the degree of accuracy required was the same for both investigations.

Comparison of these results show that:-

- (1) In general the C.C.T. observations tend to be higher than those obtained by N.P.L.
- (2) Comparison of graphs compiled from the observations listed in "Code letter A" show that "Inspection" measurements are considerably more accurate than "Workshop" measurements.
- (3) External measurements are more accurate than internal measurements, particularly up to a size of 5 inches.
- (4) Once observations in error by more than 0.001 inch have been eliminated all graphs show very similar tendencies and there is far less difference between external and internal measurements.

However, coupled with this, it should be borne in mind that far more observations are eliminated from the internal measurements than the external ones, particularly with regard to "Workshop" measurements.

In view of the wide diversity of the type of manufacture carried out by these firms it was thought possible that the performance of the heavier engineering shops would be of such a nature as to have an unfair bias on what should be a creditable performance by the lighter and more precise engineering works. Accordingly the firms were than divided into two groups, one group, containing eleven firms, was classified as doing work requiring precision skills, while all other firms were classified as heavy or less precise engineering. The mean sizes and standard deviations for each group were calculated and again graphs were plotted. Rather surprisingly there was little difference in the performances of the two groups. The only definite statement the writer could make is that for sizes under 0.4 inch, both external and internal diameters, the precise group maintained a slightly smaller deviation. All other variations seemed to be completely random in character and certainly no apparent trend was noticeable.

As the graphs produced for this analysis serve no useful purpose they have not been included.

SECTION 2 Measuring Equipment Used, Degree of Accuracy and General Conditions

Comparison of the methods used to measure the test pieces, (Fig. 4) shows that very few firms appear to possess much more than a few micrometers, verniers and slip gauges.

The N.P.L. investigation showed that most external diameters were measured by inspectors using some form of vertical comparator and slip gauges.

Apparently very few inspectors in this investigation have this type of equipment available. This view is further confirmed when it is realised that under the heading of 'Vertical Comparator and Slip Gauges' was also included the number of people using dial gauges and slip gauges. Virtually all external measurements were made using a micrometer, a rather disturbing feature being the number of observations made without the individual observers calibrating the micrometer first.

As with the N.P.L. investigation it was found that a greater variety of methods was used for internal measurements. However, the use of a micrometer still finds greatest favour, particularly on the workshop measurements, although not to the same extent as with the external measurements.

An attempt was made to assess the relative merits of the various methods of measurement which were used.

Two methods were adopted,

- (a) A comparison of the arithmetic mean errors of the results obtained by each method, as in the N.P.L. investigation,

(b) a comparison of their standard deviations, about the mean size of the respective measurements.

In both cases a minimum of five readings for any particular method was needed to ensure inclusion.

The two methods gave somewhat conflicting views, but in general follow the pattern set by the N.P.L. investigations.

However it is felt that neither methods give a satisfactory assessment of measuring equipment and that the individuals taking the measurements are, by far, more unreliable than the equipment itself.

TABLE 5. RELATIVE ACCURACIES OF MEASURING TECHNIQUES

TABLE OF ERRORS - UNITS 0.0001 INCH

External 0.04 - 1.0 inch			External 2.5 - 15.0 inch		
Method	Mean	s. d.	Method	Mean	s. d.
1	.325	2.74	1	1.674	9.80
2	-.107	5.10	2	1.398	9.88
3	.664	1.35	3	- 3.7258	10.354
4	-.316	2.24	4	.5045	5.295
5	-.323	8.63	5	.426	7.34
6	.150	.358	6		
7			7	2.5045	16.96
8	.974	1.37	8		
9			9		
10			10		
			11		
			12	- 7.92	9.016
			13	-15.169	9.989

TABLE 5. continued.

Internal 0.15 - 1.0 inch			Internal 2.5 - 13.0 inch		
Method	Mean	s. d.	Method	Mean	s. d.
1	1.842	3.903	1	1.937	10.95
2			2	.93	5.73
3	-4.364	14.75	3	1.186	9.11
4	1.525	4.245	4	- .283	6.819
5	- .368	1.944	5		
6	.903	10.19	6	24.9	15.32
7			7	6.533	3.43
8			8		
9	-8.011	21.00	9	1 2.156	15.37
10	1.355	9.967	10		
11	.611	4.06	11		
12			12		
13			13	+ 4.883	4.57
14			14		
15			15		
16			16	- 7.168	5.72
17	.069	2.96	17		
18	1.065	1.58	18	.465	1.10
19	-9.58	14.97	19		
20	- .55	1.30	20		
21			21		
22			22		
23			23		
24	6.77	14.20	24		
25			25		

Measuring Techniques UsedExternal Measurements

- | | |
|------------------------------------------|----------------------------------------|
| 1. Micrometer, | 7. Vernier, |
| 2. Micrometer and Setting Discs or Bars, | 8. Horizontal Comparator, Slip Gauges, |
| 3. Micrometer and Slip Gauges, | 9. Measuring Machine, |
| 4. Vertical Comparator, Slip Gauges, | 10. Height Micrometer, |
| 5. Micrometer Set with Plug Gauges, | 11. Jig Borer and Slip Gauges, |
| 6. Bench Micrometer, | 12. Length Standards and Slip Gauges, |
| | 13. Vernier and Slip Gauges. |

Internal Measurements

- | | |
|----------------------------------------------|----------------------------------------------|
| 1. Inside Mic. Set with External Micrometer, | 12. Inside Mic. and Measuring Machine, |
| 2. Inside Mic. Set with Slip Gauges, | 13. Horizontal Comparator and Slip Gauges, |
| 3. Inside Micrometer, | 14. Jig Boring M/c. and Slip Gauges, |
| 4. Inside Mic. Set with Shop Standards, | 15. Dial Gauge, Slip Gauges, Height Mic., |
| 5. Taper gauges and outside Micrometer, | 16. Slip Gauges and Attachments, |
| 6. Inside Calipers and External Micrometer, | 17. Bore Comparator and Slip Gauges, |
| 7. Inside Mic. Set with Vernier, | 18. Bore Comparator and External Micrometer, |
| 8. Vernier Set with External Micrometer, | 19. Drill shank and External Micrometer, |
| 9. Vernier, | 20. Plug Gauge and External Micrometer, |
| 10. Telescopic Gauge and External Mic., | 21. Plug Gauge, Comparator, Slip Gauges, |
| 11. Ball Gauge and External Micrometer, | 22. Plug Gauge, |
| | 23. Drill Shank, |
| | 24. Projector. |

In connection with the second phase of the investigation a number of measuring instruments were examined in the College Metrology Laboratory. In each case the standard, for determining whether an instrument was serviceable or not, was the specification laid down in the relevant British Standard.

Although the writer would have preferred to have checked every instrument which had been used during the measuring programme the results which have been obtained appear to be fairly representative of the measuring equipment which he has seen during his visits to the different firms.

The type of equipment which was received for test included the following:-

External and internal micrometers,
vernier calipers,
slip gauges, and
bore comparators.

The overall picture can be obtained by summarising the results as follows:-

External micrometers

20% fully serviceable,

80% with zero setting errors, these almost invariably being 'plus' errors, indicating that in general the ratchet has not been used for setting purposes. The range of setting errors extends from -0.00015 to +0.0006 inch. Of all the micrometers 40% were unserviceable due to thread errors, broken ratchets, twisted frames and threads too tight to allow easy turning of the thimble.

In view of the setting errors it was remarkable to find that all of the setting bars and discs submitted were serviceable.

Internal micrometers

33% fully serviceable,

67% with zero setting errors ranging from -0.0008 to $+0.0020$ inch.

Of the total 50% were unserviceable due to thread errors.

All of the extension bars were checked with the micrometer set at the zero position. Of these 14% were within limits, the remainder varied over a range of -0.0012 to $+0.0019$ inch.

Vernier calipers

25% fully serviceable,

75% unserviceable, all due to 'spring' jaws.

Slip gauges

Only six sets of 81 piece - inspection grade slip gauges were checked. In only one set was every piece within the limits laid down by B.S. 888. However, to be fair, one other set had two pieces which were just outside the lower limit using comparators for these measurements; it is possible that an interferometer would have shown them to be inside the limit. Of the remaining sets one had 16 pieces, another 22 pieces, and a third 25 pieces below the lower limit.

The final set was a very old one and every piece was well outside the lower limit. In fact the 1.000 inch slip was -0.000287 inch.

Bore comparators

Only two instruments of this type were checked, one being

serviceable and the other unserviceable. This does not give any reliable indication of general conditions, but did bring out another interesting point. The serviceable instrument was much older and much more used than the other one was, and this emphasises the fact that instruments which are handled correctly will stay reliable over a longer period of time than items that are mishandled or misused.

As a conclusion to this section of the report it is also worth mentioning that, in conjunction with this survey, one well known firm carried out a full survey of its measuring equipment. The following is an extract from the report which was submitted to the Works Director:

"The following are a few observations made during this measuring equipment survey.

1. Tools in general are returned to the stores and put away in a dirty or untidy condition.
2. An up-to-date stock list of measuring equipment does not exist.
3. Delicate instruments such as micrometers and combination sets etc., may be sharing a box with a handful of steel swarf.
4. Large verniers and micrometers just lie about (near machines) adjacent to cutting tools, spanners etc., unprotected.
An 18 inch to 24 inch micrometer will be found at a machine in one bay, its protective box found at a machine in another bay.

5. A large quantity of micrometers are not returned to the stores often enough for checking.
6. A number of micrometers require ratchets and lock nuts.
7. Some of the larger outside micrometers have make up pieces missing, making the instrument unserviceable for certain sizes.
8. Identification numbers of micrometers are marked on different parts of micrometer body making checking difficult.
9. Identification numbers are very faint, a magnifying glass is sometimes required.
10. A number of inside micrometers are kept permanently on certain machines.
11. There are six sets of 8 inch to 33 inch M & W inside, micrometers which are still in the makers wrappings locked in a cupboard in tool stores, and have never been used.
12. A quantity of 8 inch to 33 inch and 8 inch to 28 inch insides are badly worn, i.e. loose threads and should be replaced. Johansson are a more stable and easier to maintain micrometers.
13. Quite a proportion of micrometer boxes are broken and offer little protection.
14. Some operators are holding as many as a dozen micrometers at one time.
15. One set of slip gauges are badly marked due to corrosion, the sizes are not clear enough to read.

16. Combination sets and optical protractors require attention.
17. Booking in and out of tools leaves much to be desired, i.e. too much paper work involved.

SECTION 3 Estimated Accuracies of Measurement

The information supplied by the observers regarding the estimated accuracy of measurement is shown in Fig. 5. One of the disturbing features about this section is the high proportion of observers who did not volunteer any information on this aspect. This amounts to some 10% - 20% of 'Inspection' observers and up to 40% of 'Workshop' observers.

Of those who did volunteer information, the trend follows that set by the N.P.L. investigation, i.e. a tendency to be optimistic about the accuracy of their measurements. Nevertheless the spread about the limits laid down on the charts appears to be much more even than was obtained on the N.P.L. investigation, thus showing a little more conservatism.

It may also be recalled that earlier mention was made of the fact that the larger test pieces had some taper on the measuring faces. It is interesting to note that, of all the observers who took part in the investigation, the following number only noted this on the return forms.

Test piece	Number of Observers Noting	Amount of Taper on Piece
8 in internal	15	.002 inch
13 in internal	14	.0025 inch
10 in external	1	.003 inch
15 in external	2	.0001 inch

In connection with the second phase, i.e. attempting to discover the causes of the inaccuracies which occur, one of the requests made to the firms was that asking for the managers to give their assessment of the accuracy to which they would expect their employees to be able to work. The response to this request was as disappointing as the response from the observers themselves. Assessments were given for only forty-one observers, out of a total participating number of one hundred and fifty-two.

For convenience four grades of degree of accuracy of work were laid down and each allocated a code letter. These grades were:-

- Grade (a) work with a tolerance up to and including 0.0005 inch,
- (b) work with a tolerance up to and including 0.001 inch,
- (c) work with a tolerance up to and including 0.002 inch,
- (d) work with a tolerance up to and including 0.005 inch.

The actual performance of each of these forty-one observers was then compared with the assessment assigned to them. In this case the criterion which determined whether the observer justified his assessment or not was that his measured size for each test piece should not be in error by more than \pm half of the tolerance grade to which his ability was related. It was appreciated that in practice a man working to a specified tolerance should have a measuring ability much higher than that allowed in this instance. Nevertheless, in view of the fact that most of these observers were machine tool operatives, it was felt that short of asking these people actually to manufacture parts to the tolerance stipulated this was the only fair method of assessment possible.

The assessment of the shop managers and the number of operatives who justified this assessment are shown in Table 6.

TABLE 6. ASSESSMENT AND ABILITY OF OPERATIVES

Nominal Work Size		Grade (a)		Grade (b)		Grade (c)		Grade (d)		TOTALS		
		No. of Operatives in grade	No. achieving grade	"	"	"	"	"	"	No. of operatives graded	No. achieving grade	Assessed % Correctly
0.04 in	External	33	29	8	8	-	-	-	-	41	37	90
	Internal	-	-	-	-	-	-	-	-	-	-	-
0.15 in	External	33	27	8	7	-	-	-	-	41	34	83
	Internal	23	19	2	2	-	-	-	-	25	21	84
0.4 in	External	33	26	8	6	-	-	-	-	41	34	83
	Internal	23	18	2	2	-	-	-	-	25	20	80
1.0 in	External	33	12	8	7	-	-	-	-	41	19	46.5
	Internal	26	14	2	2	-	-	-	-	28	16	57
2.5 in	External	33	17	8	7	-	-	-	-	41	24	58.5
	Internal	23	11	8	1	-	-	-	-	31	12	38.5
5.0 in	External	30	11	7	6	4	3	-	-	41	20	49
	Internal	22	10	14	4	5	4	-	-	41	18	44
10.0 in 8.0 in	External	24	14	12	2	5	3	-	-	41	19	46.5
	Internal	20	6	15	1	6	6	-	-	41	13	32
15.0 in 13.0 in	External	17	6	18	6	6	4	-	-	41	16	39
	Internal	13	4	22	8	6	2	-	-	41	14	34

From the results shown in this table it can be assumed that,

- (a) the employers are not fully conversant with the skills and abilities of their employees, and
- (b) that there appear to be no systems of testing of employees' abilities either on entering the firms or at periodic intervals.

SECTION 4 Comparison of Standard Deviation to B.S. 1916
"Limits and Fits for Engineering"

One of the major questions which keeps arising in the production departments is, "Can we produce work to the limits laid down?"

In an attempt to give some guidance on this matter a comparison was made between the standard deviation of the industrial errors, and the tolerances stipulated by B.S. 1916 "Limits and Fits for Engineering" for Tolerance Grades 6., 7. and 8.

When one compares errors in measurement with allowable tolerance it is as well to realise that :-

- (a) It is generally accepted that the error of measurement should not exceed 10% of the tolerance.
- (b) When considering a Gaussian distribution approximately 68% only of all the readings lie inside the limits of ± 1 .s.d. and that approximately 95% lie inside the limits ± 2 .s.d.

Thus if we wish to take into account all of the observations used to derive a particular value of standard deviation we must accept that the spread of errors of measurement will extend over 4.s.d.

Table 7 shows that 4.s.d. commonly exceeds the value of tolerance specified for grades I.T. 6., 7. and 8., i.e. errors in measurement account for all the tolerance and nothing is left for production.

Therefore, it appears more practical to compare 2.s.d. with the tolerance, and, if we accept (a) above, that 2.s.d. expressed as a percentage of the tolerance may be taken as a measure of the adequacy of the results.

Under these conditions Table 7 clearly shows the inadequacy of the industrial measurements, if we accept that the recommendations of B.S. 1916 are realistic.

This table was prepared using information obtained from all of the firms who took part in the survey. A further table was prepared in which the value of 2.s.d., taken from the results obtained by the 'precision' graded firms only, was compared to the requirements of B.S. 1916, I.T.6., I.T.7., and I.T.8. These are shown in Table 8, and again emphasise the conclusion which was made in Section 1 of the results, i.e. that these results are slightly better for the smaller diameters, but are no better, and in some cases worse, than the overall picture for the larger diameters.

NOMINAL SIZE	INSPECTION		TOLERANCE					WORKSHOP		TOLERANCE						
	4 s.d.	2 s.d.	I.T.6.	%	I.T.7.	%	I.T.8.	%	4 s.d.	2 s.d.	I.T.6.	%	I.T.7.	%	I.T.8.	%
0.04	.44	.22	.25	88	.40	62	.60	37	.52	.26	.25	104	.40	65	.60	43
	-	-	-	-	-	-	-	-	-	-	-	-	-	-	-	-
0.15	.48	.24	.30	80	.50	48	.70	34	.68	.34	.30	113	.50	68	.70	48
	.80	.40	133	133	80	80	57	57	.80	.40	.40	133	.50	80	80	57
0.4	.48	.24	.40	60	.70	34	1.0	24	.60	.30	.40	75	.70	40	1.0	30
	.68	.34	85	85	48.5	48.5	34	34	.88	.44	.40	110	.80	59	1.0	44
1.0	.64	.32	.50	64	.80	40	1.2	27	.68	.34	.50	68	.80	42	1.2	28
	.76	.38	76	76	47	47	32	32	1.0	.50	.50	100	.80	62	1.2	42
2.5	.84	.42	.70	60	1.2	31	1.8	23	.76	.38	.70	59	1.2	32	1.8	21
	1.08	.56	80	80	42	42	31	31	1.04	.52	.70	74	1.2	43	1.8	29
5.0	.88	.44	1.0	44	1.6	27	2.5	17	1.00	.50	1.0	50	1.6	31	2.5	20
	1.00	.50	50	50	31	31	20	20	1.12	.56	1.0	56	1.6	35	2.5	22
8.0	.80	.40	1.2	33	1.8	22	2.8	14	1.12	.56	1.2	48	1.8	34	2.8	20
	1.08	.54	1.2	45	2.0	27	3.0	18	1.04	.52	1.2	43	2.0	26	3.0	17
13.0	1.04	.52	1.4	37	2.2	24	3.5	15	.96	.48	1.4	34	2.2	14	3.5	14
	1.04	.52	1.4	37	2.2	24	3.5	15	.96	.48	1.4	34	2.2	14	3.5	14

TABLE 7. Comparison of Standard Deviation to B.S. 1916. (using number of observations listed under Code Letter D, Table 3) Units - 001 in.

	Precision Firms Inspection		Tolerance						Precision Firms Workshop		Tolerance					
	2.s.d.		I.T.6.	%	I.T.7.	%	I.T.8.	%	2.s.d.		I.T.6.	%	I.T.7.	%	I.T.8.	%
0.04 in	External	.2	.25	80	.40	50	.60	33	.26	.25	104	.40	65	.60	43	
	Internal	-							-							
0.15	External	.17	.30	57	.50	34	.70	24	.28	.30	93	.50	50	.70	40	
	Internal	.32		106		64		46	.40		133		80		57	
0.4	External	.24	.40	60	.70	34	1.0	24	.30	.40	75	.70	40	1.0	30	
	Internal	.30		75		43		30	.44		110		59		44	
1.0	External	.30	.50	60	.80	37	1.2	25	.30	.50	60	.80	37	1.2	25	
	Internal	.40		80		50		33	.58		116		72		48	
2.5	External	.50	.70	72	1.2	42	1.8	28	.44	.70	63	1.2	37	1.8	27	
	Internal	.52		74		43		29	.58		83		48		32	
5.0	External	.46	1.0	46	1.6	29	2.5	18	.50	1.0	50	1.6	31	2.5	20	
	Internal	.42		42		26		17	.54		54		34		21	
10.0	External	.54	1.2	45	2.0	27	3.0	18	.56	1.2	47	2.0	28	3.0	19	
	Internal	.40		33	1.8	22	2.8	14	.38		32	1.8	21	2.8	14	
15.0	External	.42	1.4	30	2.2	19	3.5	12	.36	1.4	26	2.2	16	3.5	10	
	Internal	.88		63	2.2	40	3.5	25	.72		51	2.2	33	3.5	21	

TABLE 8. Comparison of Standard Deviation to B.S. 1916. Precision firms results only; Units 0.001 in.

SECTION 5 Equation for Standard Deviation

In both N.P.L. investigations empirical equations were derived relating standard deviation and diameter of work piece. The experimental results of the two investigations appeared to link up reasonably well with the exception that those at 4 in in the first investigation were less accurate than those at 5 in in the second. This was explained as possibly due to the fact that the firms chosen for the second investigation were probably more used to, and better equipped for, work of this size than the firms who took part in the first one.

Nevertheless it was believed that all diameters from 0.02 in to 80 in could be represented by suitable equations. Accordingly the N.P.L. revised and prepared additional formulae to cover all groups within this size range, and these appear in Table 9 below.

TABLE 9. EQUATIONS FOR STANDARD DEVIATION : UNIT 0.001 IN

	Inspection	Workshop
External	$0.10 + 0.034d.$	$0.10 + 0.050d.$
Internal	$0.25 + 0.005d.$ up to 26 in Thereafter $-0.25 + 0.026 d.$	$0.25 + 0.021d.$

Diameter d. expressed in inches

It was felt desirable to check whether or not the results of this investigation conformed to these equations. Therefore

the lines corresponding to the equations were drawn (Figure 6) and on these were plotted the values of the standard deviations corresponding to the diameters of the test pieces as obtained in this investigation.

Examination of these graphs gives rise to the following conclusions.

Figure 6-1. In this case the values for this experiment lie almost directly on the line produced by the N.P.L. equation giving near perfect conformity for inspection measurements of external diameters.

Figure 6-2. This is probably the worst matching fit, but it is noticeable that on the smaller sizes, up to 5.0 in, the slope of the N.P.L. line lies close to the slope produced by the current values. The main difference lies on the larger sizes and this can be accounted for by the fact that the N.P.L. equation was derived from two sets of results. One from a size range of 0. - 5 in and the other from a size range of 4 in - 80 in. Also the N.P.L. investigations were carried out with a period of some years between them; and by firms which were nominally employed on work covered by each size range. This could therefore have the effect of showing the change of slope at around the 4 in - 5 in size.

Figure 6-3 and 6-4. Both show very similar slopes to those obtained from the empirical equations. As these equations are of the form $a + bx$ it would appear that, with

some modification to the constant 'a', the results of this investigation also conform to them.

It is possible therefore to express the opinion that, while the inaccuracies shown are slightly greater than those shown by the N.P.L. investigations, nevertheless the same general trend is shown.

SECTION 6 Working Conditions, Training and Experience of Operatives

Investigation into the conditions under which the measurements were taken revealed the following facts.

- (1) That only four firms possessed a standards room, or inspection room where the temperature was controlled, and ideal conditions existed.
- (2) The majority of measurements were taken in machine shops where large doors were being constantly opened and closed, thus creating draughts, along with temperature fluctuations of up to 20°F in 24 hours.
- (3) Most firms replied that the atmosphere was clean and free from dust, although in the writer's opinion quite a large number were far from it.
- (4) Many firms expressed the view that the equipment they possessed was not adequate from the purpose of the tests.
- (5) All of the firms allowed the operatives time in which to take the measurements, thus no person could claim that any errors found were due to not having sufficient time to do the job properly.

Enquiries as to the type of training and experience of the operatives showed:-

- (1) All participants had served their apprenticeships as fitters, turners, or occasionally tool makers.
- (2) Very few had been given special training or instruction in metrology. Up to the time this investigation was started

it would appear that only one or two firms had internal training schemes, or sent their employees on courses at local technical colleges. It was noticeable that these firms had better results than the others, although their number was so small that insufficient data was available to make a definite assessment.

- (3) The majority of people engaged on inspection duties were over forty years of age.

GENERAL COMMENTS

In any form of investigation such as this one, one must bear in mind that the conditions are somewhat false when compared to the normal working environment.

There is always the possibility that by giving an operative a set of special test pieces, and informing him that he is taking part in a survey into the accuracy of measurements he will produce results which are entirely out of character to his normal work.

For example the man who normally tends to say, "That is near enough" will no doubt take extra care with the test pieces, despite being asked to treat them as normal workpieces. Similarly a conscientious workman may become so nervous as to produce results which are much inferior to his normal practice.

Another comment which was made during the investigation was that the men were used to taking measurements with the job in the machine, and therefore they would get worse results than usual. Personally, the writer feels that having the job in the machine increases the risk of obtaining errors due to the inconvenience of reaching the part, the risk of dirt, or films of coolant being present, and above all the fact that if the measurement is being taken straight after machining the errors due to temperature will arise, although this last point should make no difference to the results in this case.

Nevertheless, it was pleasing to find the enthusiastic co-operation which was present throughout the survey and, to some extent, which has been carried on since the survey finished.

Since the results were first released to the firms over fifty inspectors have attended Constantine College on short, one week, courses on precision metrology and the demand is still not satisfied. It is also gratifying to note the number of requests for advice and assistance in problems of measurement which the writer has received from the local firms. Several firms have carried out surveys on their own measuring equipment and have become more accuracy conscious.

However, there are still a large number who are quite content to say, "It's near enough" and as yet have made no effort to improve the quality of their product. This is particularly annoying when it is appreciated that in many cases the cost involved would be negligible. It is still baffling to find the manufacturer who will spend £5,000 on a machine tool, and then refuse to spend £5 on a micrometer.

Nevertheless, the writer feels that this investigation has served its purpose, and in general has shown:-

- 1) That inaccuracies in measurement are prevalent in the Teesside engineering industries.
- 2) That many of the errors are shown to be the result of sheer carelessness e.g. errors of 1 in or more.
- 3) That many firms would have difficulty in producing interchangeable batches of work to the tolerance laid down in British Standard Specification 1916, particularly grades I.T.6. and I.T.7.
- 4) That most operatives are rather optimistic about the accuracy of their measurements.

- 5) That in some cases the employers have little knowledge of the capability of their operatives, tending to be too optimistic.
- 6) That there is a shortage of the more sophisticated types of measuring equipment in this area.
- 7) That what equipment there is tends to be sadly neglected, not checked at regular intervals, and rarely calibrated correctly.
- 8) That insufficient training is given to inspectors and operatives, particularly in the fundamental principles of metrology.
- 9) That in general the results obtained from the Teesside industries are remarkably similar to those obtained by the N.P.L. investigation.
- 10) That active co-operation between industry and the colleges is possible, to the mutual advantage of all concerned.

As a final comment I would like to throw out the suggestion that this investigation, along with the two previous N.P.L. investigations, leads to the hypothesis that the whole of the British engineering industry is in no better condition. It would, therefore, be of immense value if a number of similar, simultaneous investigations could be organised on a nation wide basis, co-ordinated by a body such as the N.P.L. Immediately following publication of the results a second Quality and Reliability Year, or something similar, should be organised using the results obtained as propoganda during the publicity drive.

Then, and only then I submit, will British engineering re-attain its leading position in the manufacture of products of high quality and reliability.

APPENDIX I

Reference has been made in the report to a normal Gaussian distribution. Such a distribution is illustrated in Fig. 7 and it has been found to represent approximately a great number of the frequency distributions in practice. It follows a mathematical formula and the area under the curve represents the total number of the measurements. The proportion of the total falling within vertical bands of various widths has been indicated: for example, if a particular diameter were measured by a large number of firms, sixty-eight per cent of their results would be expected to have a value differing from their algebraic mean by not more than the standard deviation of all their results.

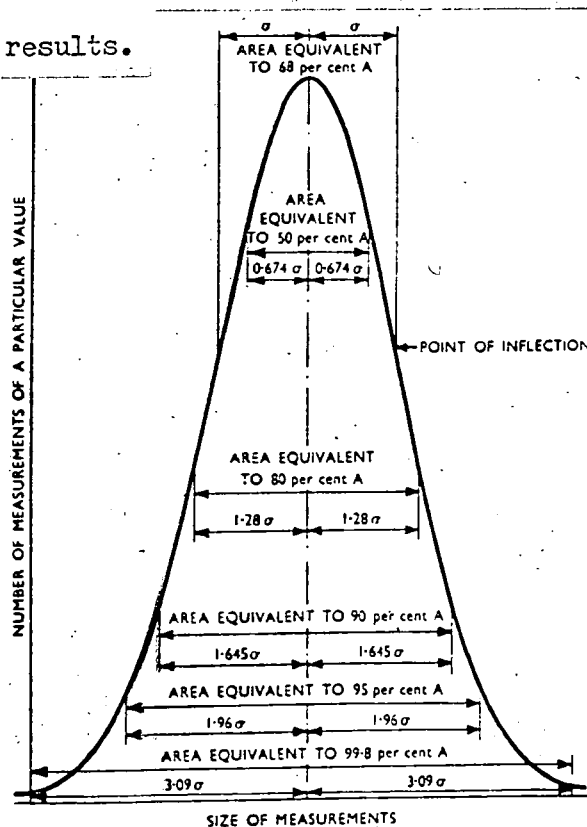

Fig. 7. Gaussian curve of distribution of industrial measurements
 σ , Standard deviation.

APPENDIX IIList of References Quoted

- 1) Leinweber, P. "Messunsicherheit (Measuring Uncertainty)"
 "TZ für praktische Metallbearbeitung, 1960,
 54, (7), 433.
- 2) Nickols, L.W. & Oakley, T.R.J. "The influence of measuring force,
 stylus radius and surface finish on the
 accuracy of measurement of workpieces on a
 comparator". Proc. Inst. Mech. Engrs.
 1961, 175 (3) 195.
- 3) Harrison, P.W. "An Investigation into the Accuracy of the
 Industrial Measurement of Sizes up to eighty
 inches" Proc. Inst. Mech. Engrs. 1955, 169,
 (47) 977.
- 4) Harrison, P.W. "Investigation into the Accuracy of Industrial
 Measurement of Sizes between 0.03 inches and
 5 inches". Proc. Inst. Mech. Engrs.
 1961, 175, 211.

Other Works Consulted in the Preparation of this Thesis

- Tornebohm, H. "The Units of Length Used Down Through the
 Centuries" Microtechnic, Vol. X, 4, 180.
- Barrel, H. "The Bases of Measurement", Proc. Inst.
 Prod. Engrs. 37, 1, 3.
- Nickols, L.W. "The Measurement of Length" Proc. Inst. Mech.
 Engrs. 1964, 7.

- Berriman, A.E. "Historical Metrology" J.M. Dent & Sons Ltd.
London 1953.
- Sawin, N.N. "Report on the Measurement of Large Work Pieces,
Measuring Equipment, System of Fits over
500 mm". Symposium on Engineering Dimensional
Metrology", N.P.L., H.M.S.O., London.
- Jolly, T.P. "Problems of Large Scale Measurement in the
Heavy Electrical Industry". Symposium on
"Engineering Dimensional Metrology", N.P.L.
H.M.S.O., London.
- Jolly, T.P. "The Problems relating to the Accuracy of
Measurement in the Heavy Electrical and
Mechanical Engineering Industries". Conference
on "The Accuracy of Industrial Measurement of
Length and Diameter" N.P.L., H.M.S.O., London.
- Moore, M.B. "Theory and Application of Mechanical Engineering
Measurements". D. Van Nostrand Co. Inc. London.

ACKNOWLEDGEMENTS

It is wished to thank all firms who have taken part in this investigation, and in particular thanks must go to the National Physical Laboratory for their assistance and the loan of most of the test pieces used in this investigation.

Acknowledgement is also made to the various members of the staff of Constantine College of Technology and to Professor G. R. Higginson of the University of Durham for their assistance in the preparation of this thesis.

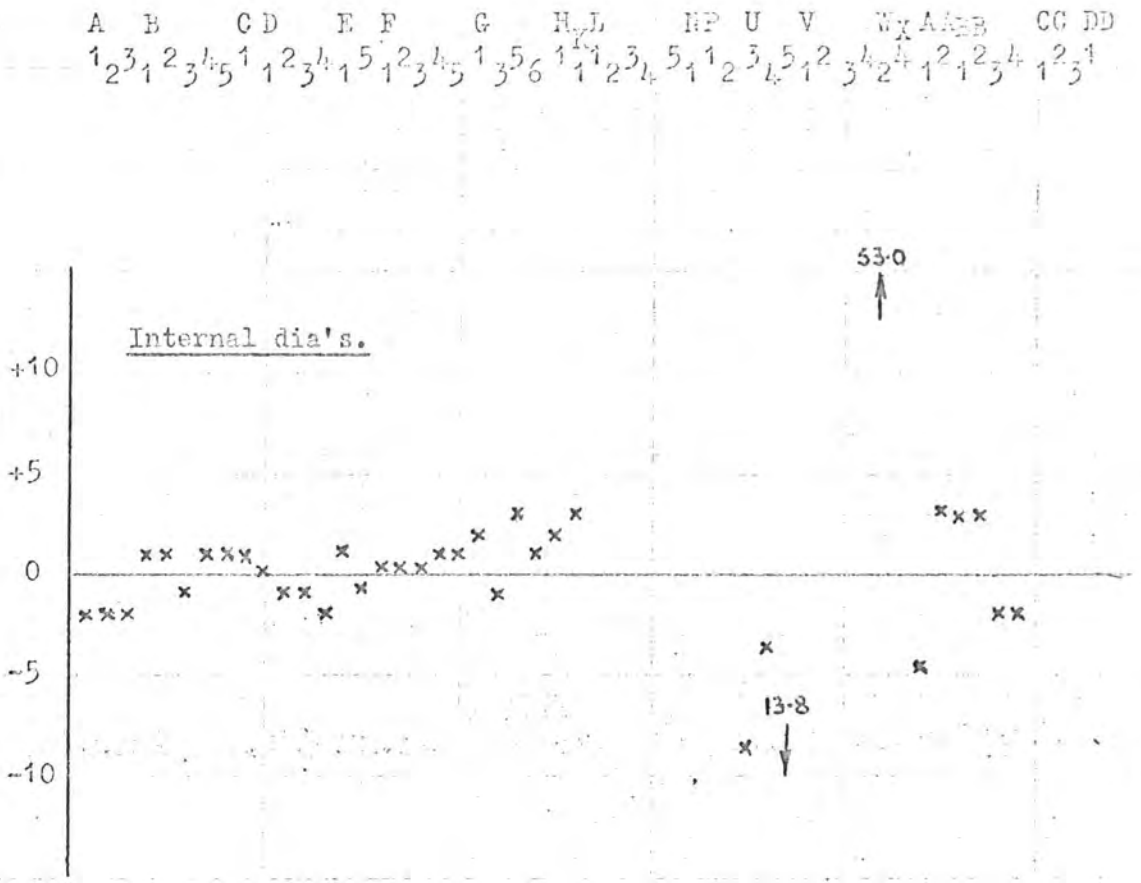
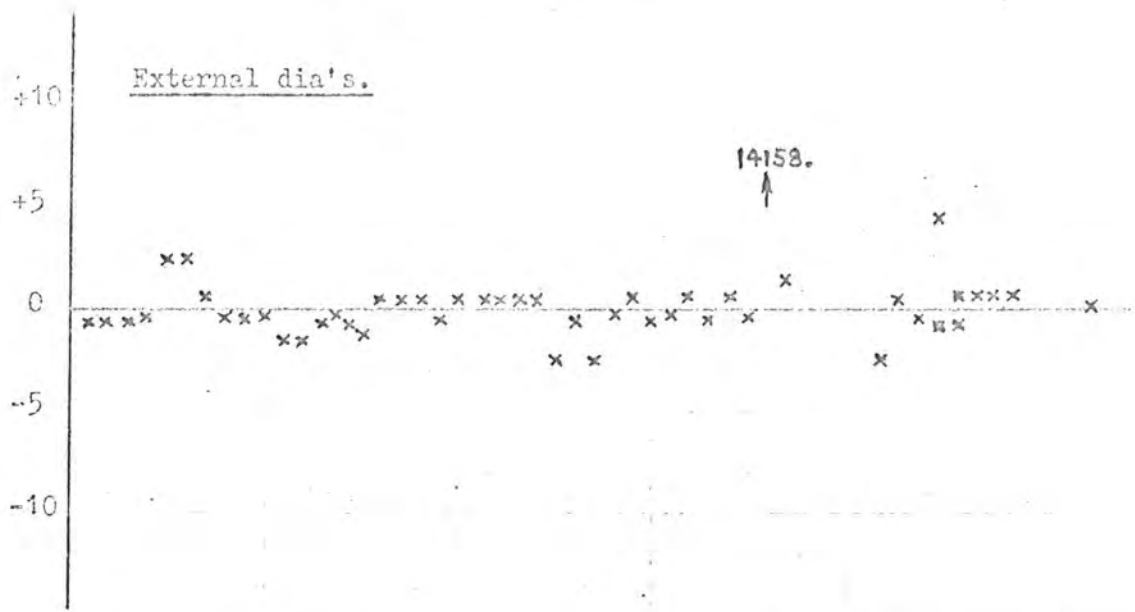
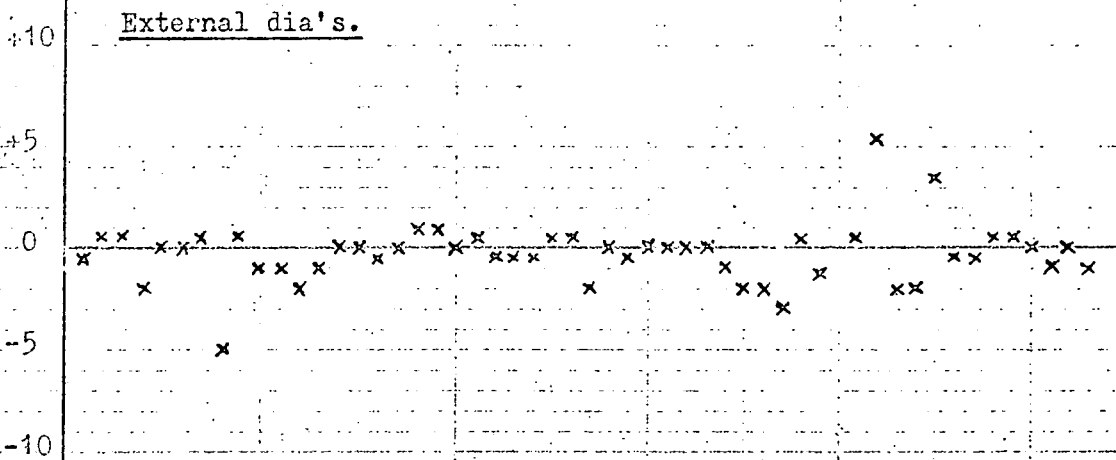

Fig.1. Difference between Industrial results & C.C.T. results.

(Units :- 0.0001 in)



A	B	CD	E	F	G	H ^K L	NP	U	V	WX	AA	BB	CC	DD
1	2	3	4	5	1	2	3	4	5	1	2	3	4	5
2	3	4	5	1	2	3	4	5	1	2	3	4	5	1

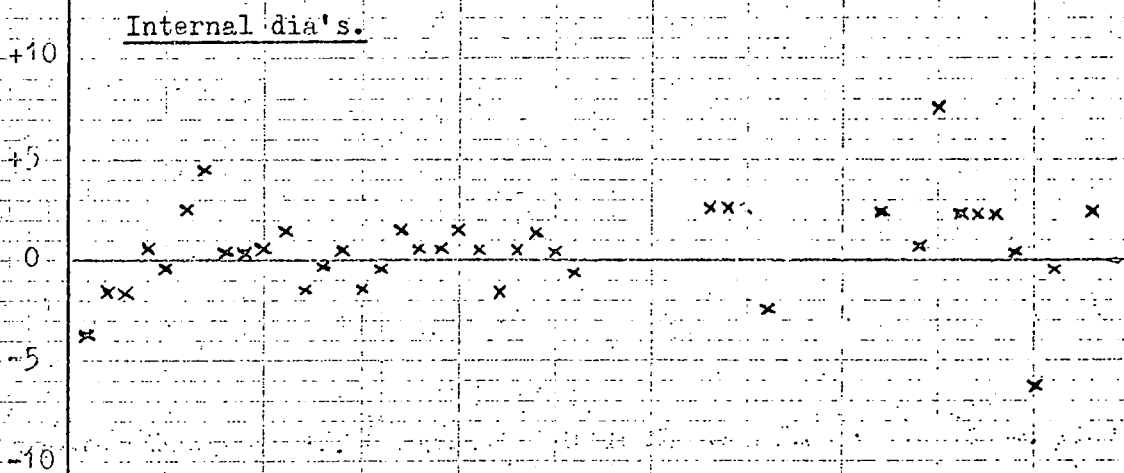

Fig.1. Difference between Industrial results & C.C.T. results.

(Units :- 0.0001-in)

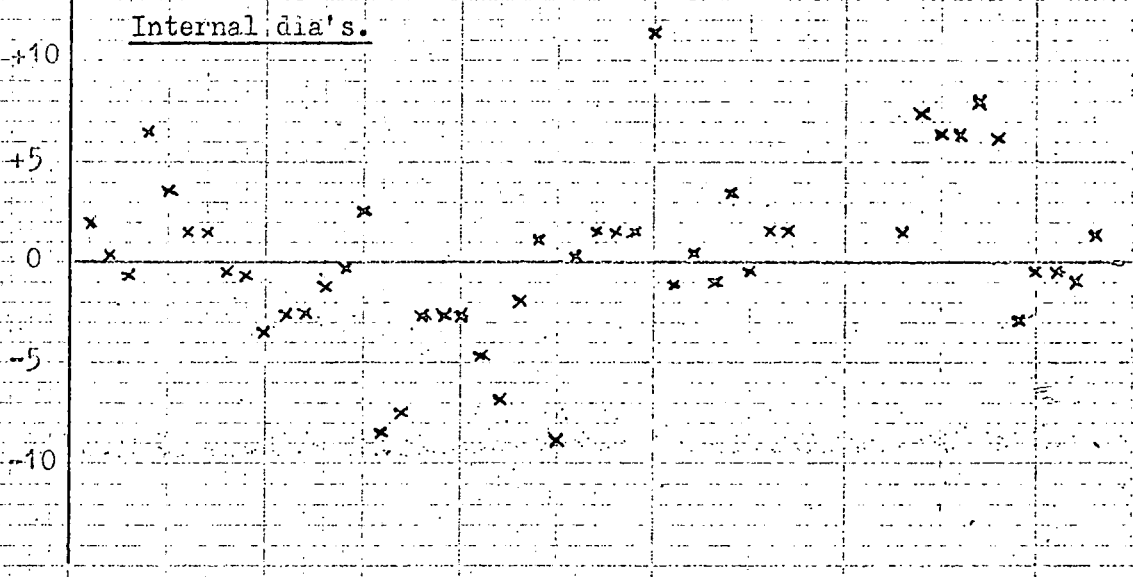
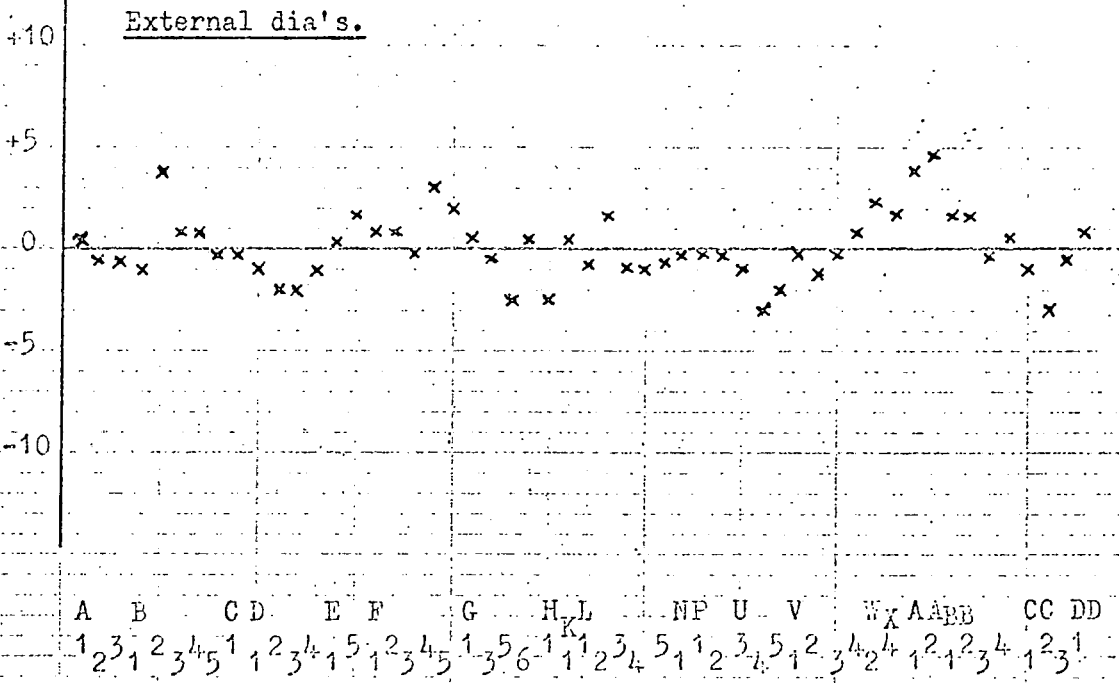

Fig.1. Difference between Industrial results & C.C.T. results.

(Units :- 0.0001 in)

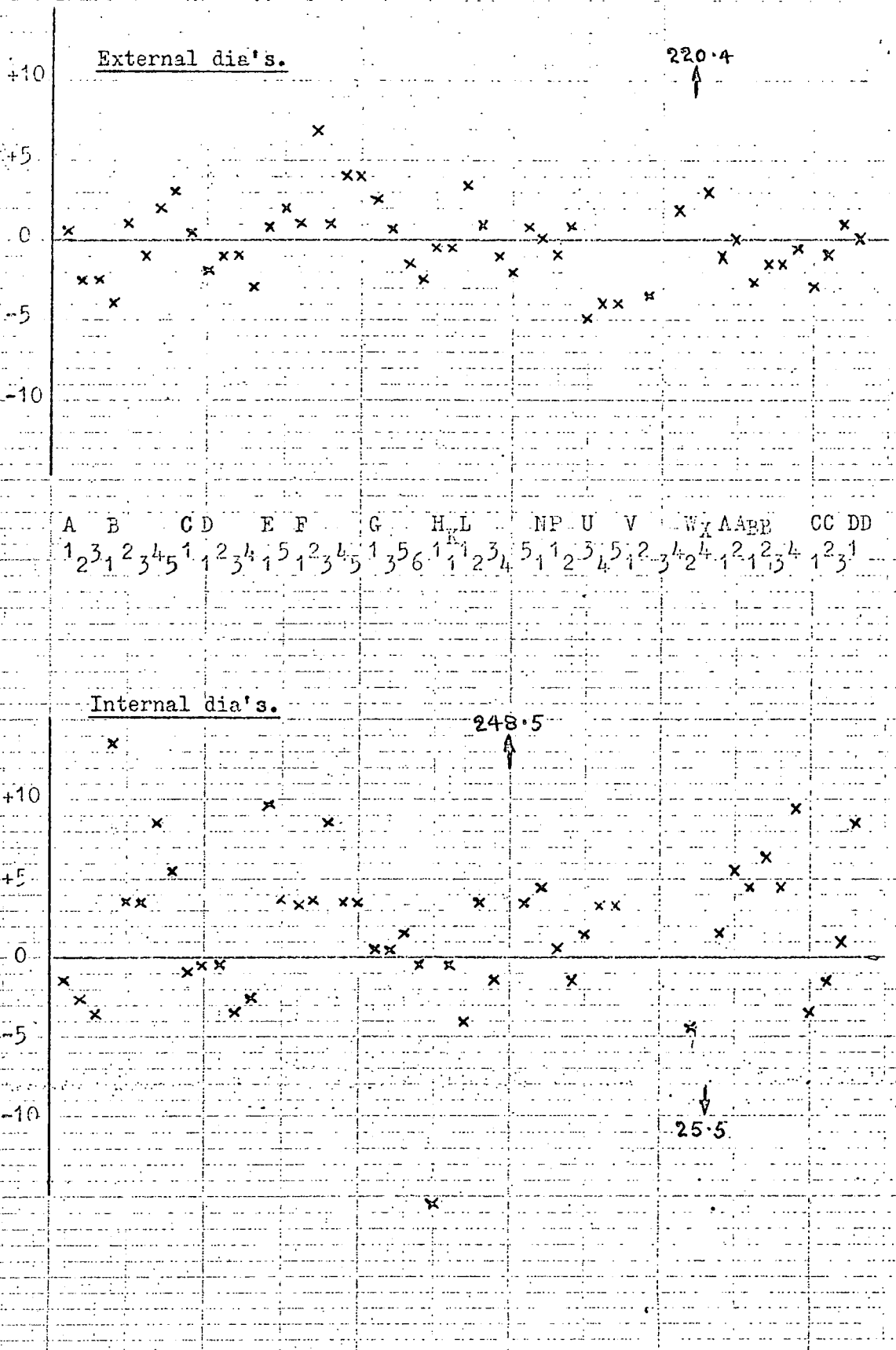
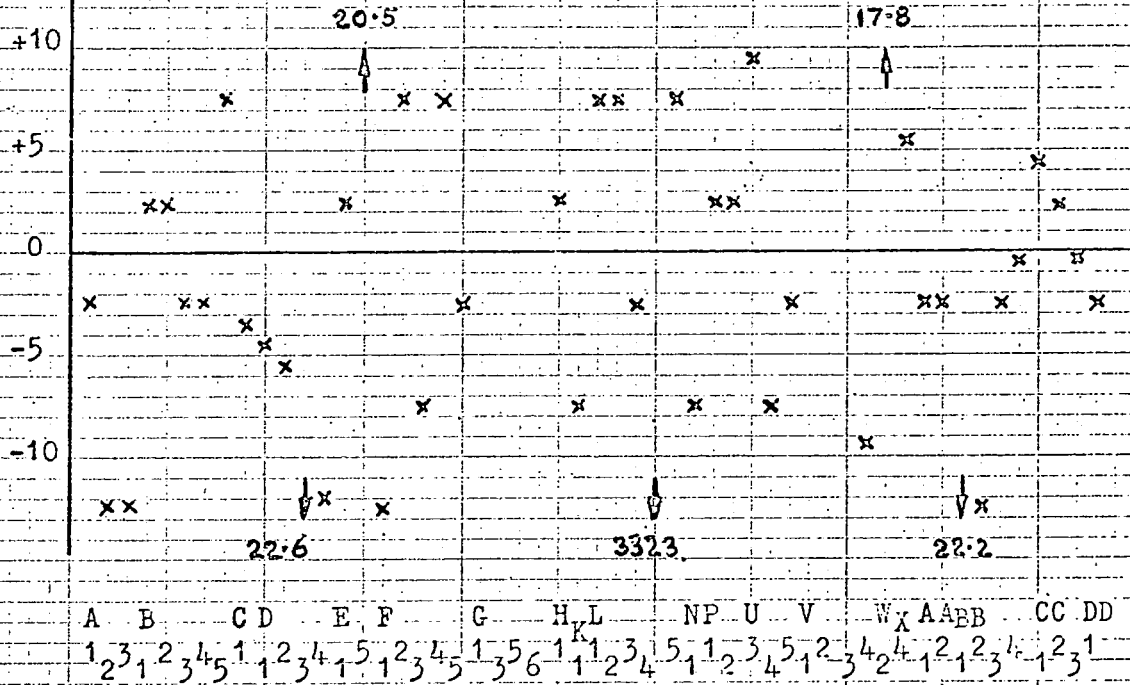

Fig.1. Difference between Industrial results & C.C.T. results.

(Units :- 0.0001 in)

INSPECTION

15.0 in. External dia.



13.0 in. Internal dia.

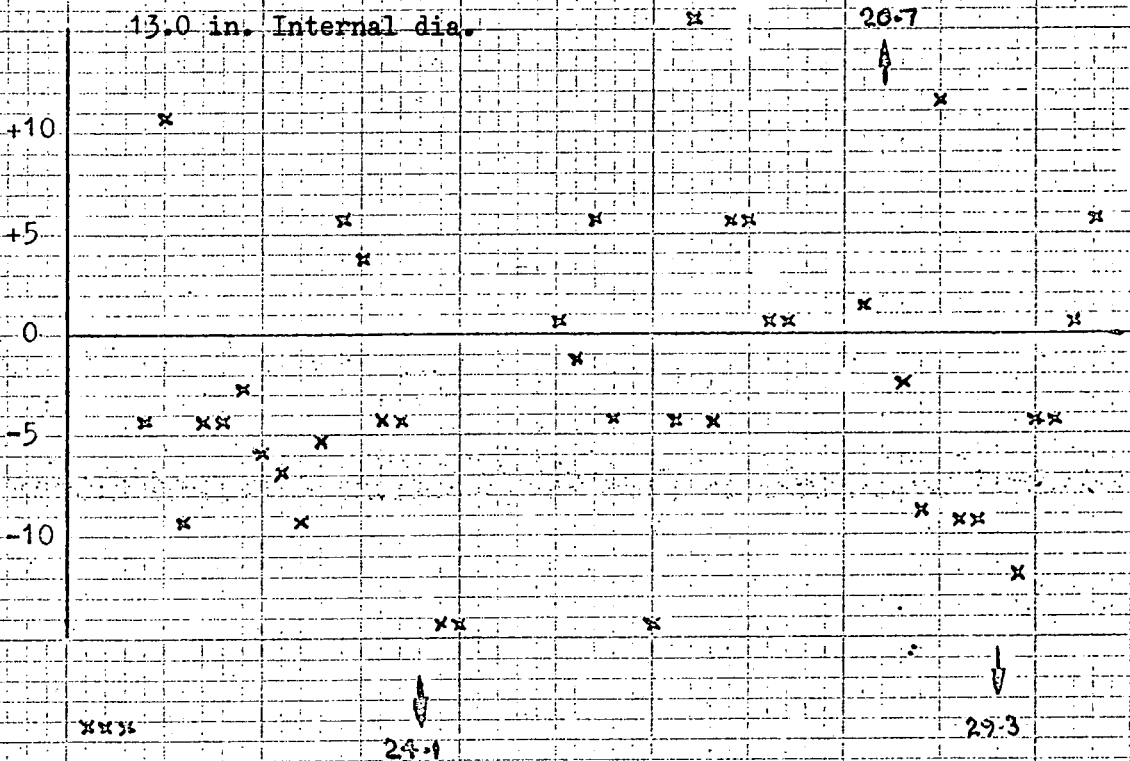

Fig.1. Difference between Industrial results & C.C.T. results.

(Units :- 0.0001 in)

External diameters

+10
+5
0
-5
-10

O.C.F. III.

19.4
A

3581.
A 3601.
x A

3554.
4797 A
A

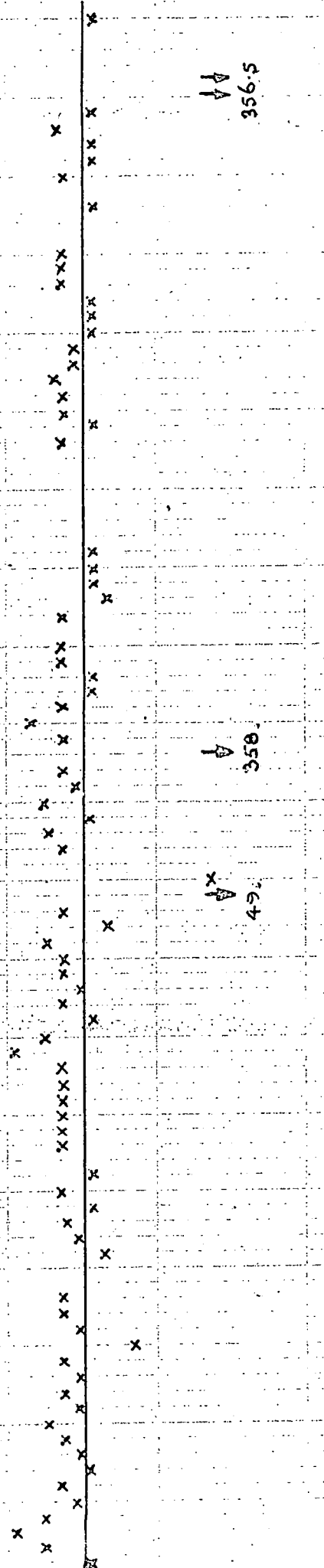

49.
A

358.
A

356.5
A A

Internal diameters not submitted

+15
+10
+5
0
-5
-10
-15

Fig: 1. Difference between Industrial results and C.C.T. results (Units :- 0.0001 in.)

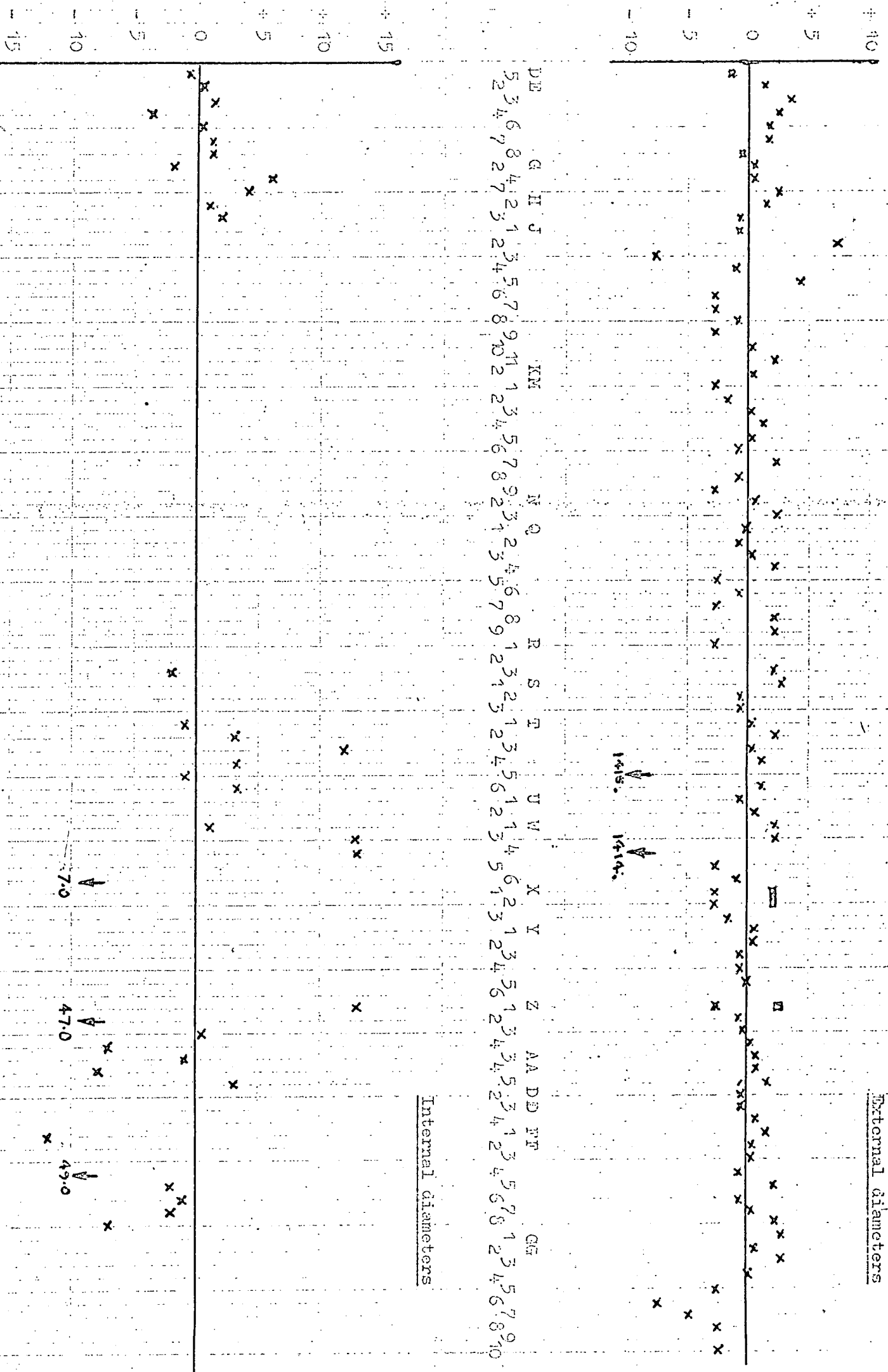
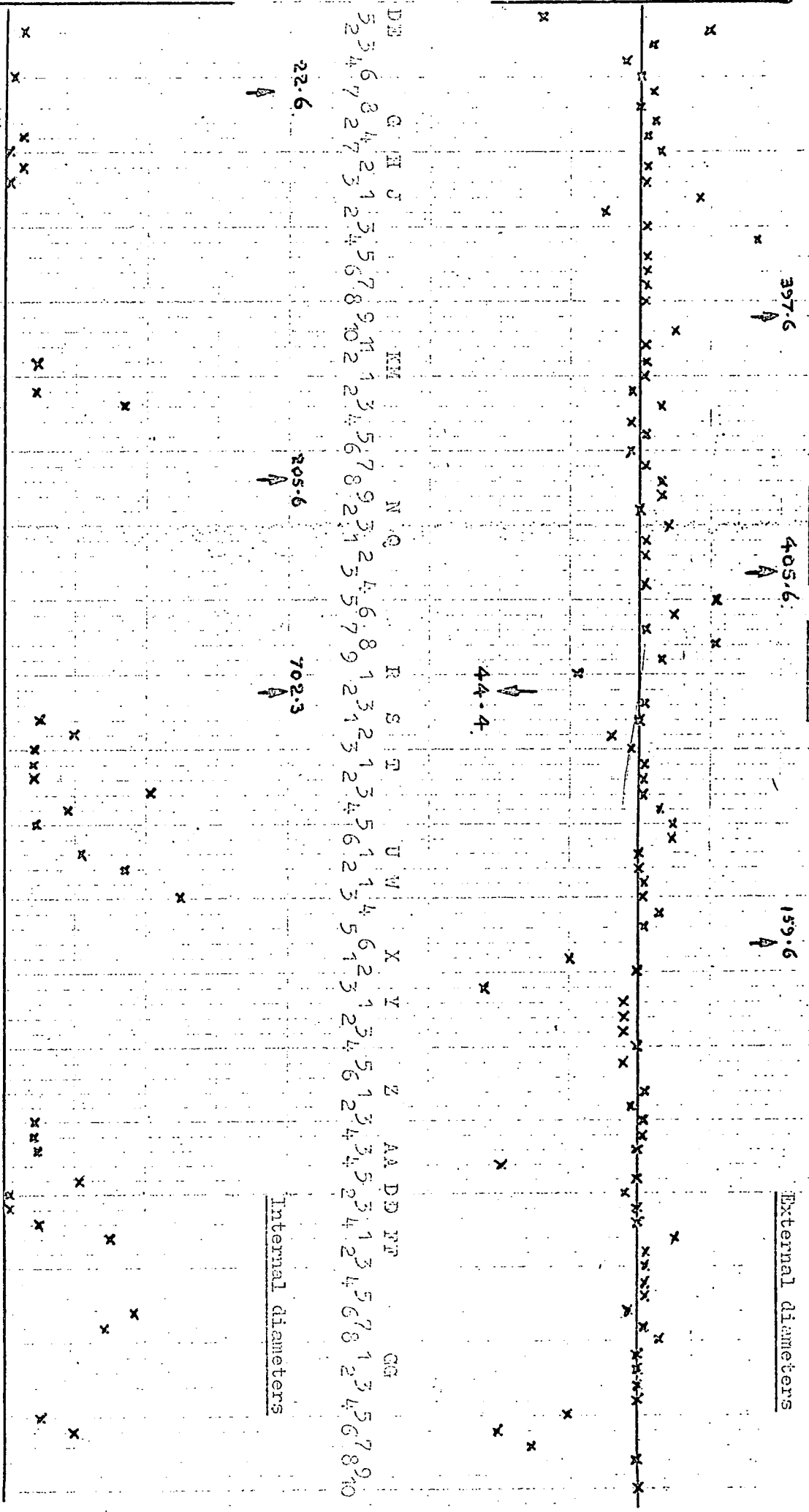

Fig. 1. Difference between Industrial results and C.C.P. results (Units :- 0.0001 in.)

+ 10
+ 5
0
- 5
- 10
- 15



External diameters

Internal diameters

DE G H J K L M N O P Q R S T U V W X Y Z AA DD TT GG
 5 3 4 6 7 8 2 1 2 3 4 5 6 7 8 9 10 1 2 3 4 5 6 7 8 9 10 1 2 3 4 5 6 7 8 9 10
 22.6 205.6 702.3 44.4 82.7 47.7 32.7 42.7

FIG. 1. Difference between industrial results and C.C.T. results (Units :- 0.0001 in.)

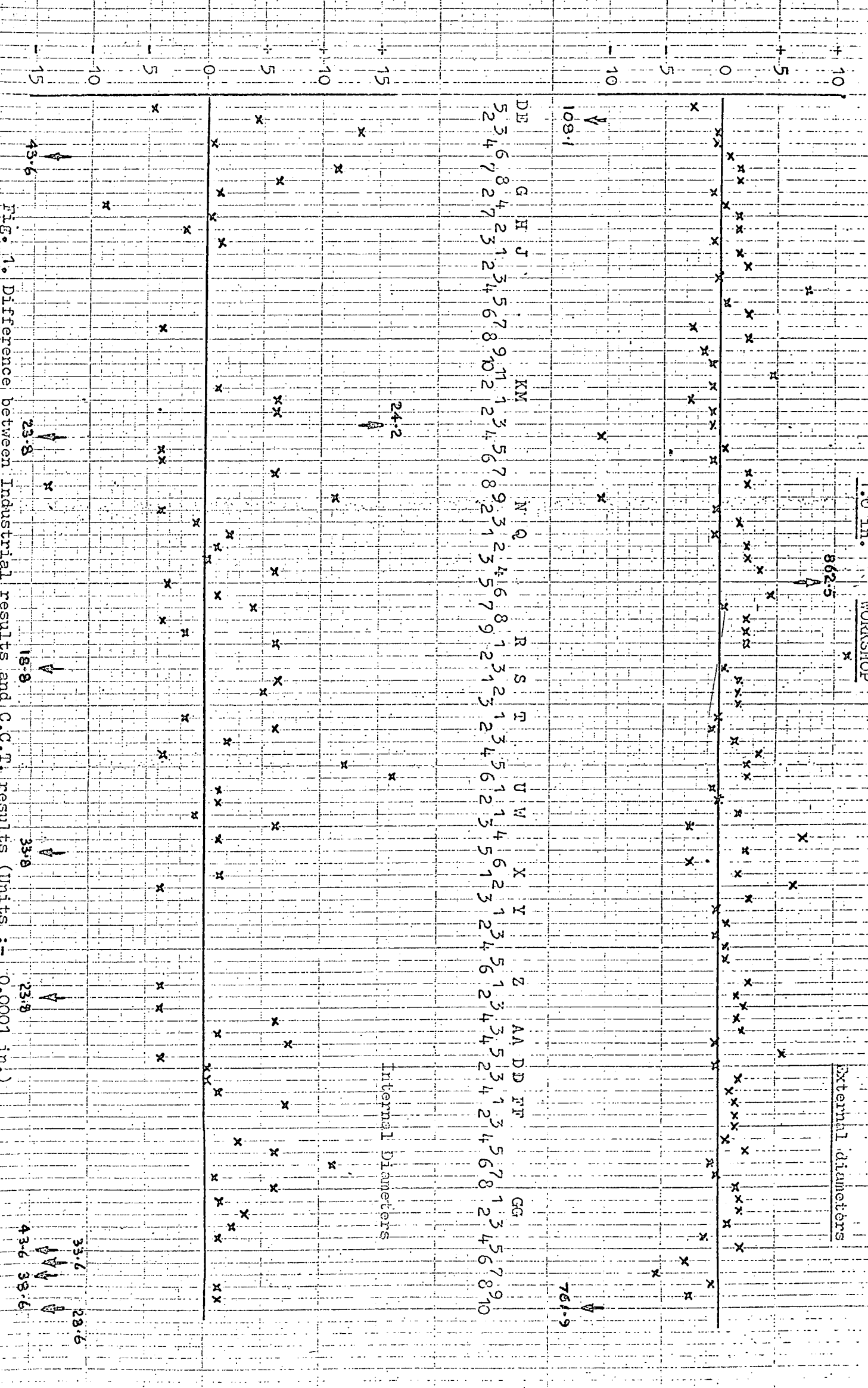

WONSHOP

862.5

External diameters

108.1

761.9

DE G H J KM N Q R S T U V X Y Z AA DD FF GG
 5 2 3 4 7 8 2 4 2 1 2 3 4 5 6 7 8 9 10 2 1 2 3 4 5 6 7 8 9 11 1 2 3 4 5 6 7 8 9 2 1 2 3 4 5 6 7 8 9 1 2 3 4 5 6 1 2 3 4 5 6 1 2 3 4 3 4 5 2 3 4 2 3 4 5 6 7 8 1 2 3 4 5 6 7 8 9 10

24.2

Internal diameters

-15
-10
-5
0
+5
+10
+15

43.6
23.8
18.8
33.8
23.8
33.6
28.6
43.6
33.6
33.6

Fig. 1. Difference between Industrial results and C.C.T. results (Units :- 0.0001 in.)

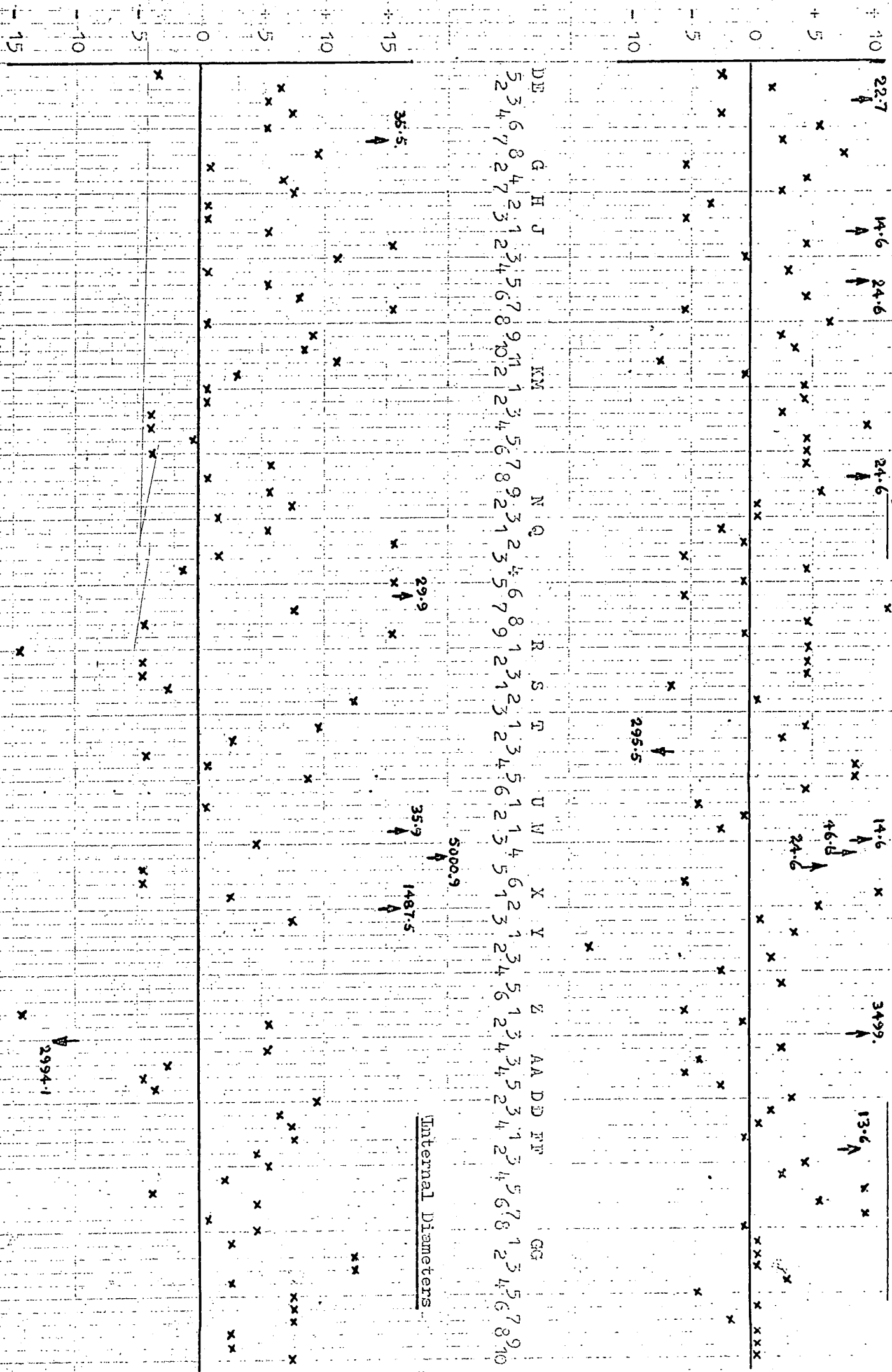

5.0 in. External Diameters

Internal Diameters

Fig. 1. Difference between Industrial results and C.C.T. results (Units :- 0.0001 in.)

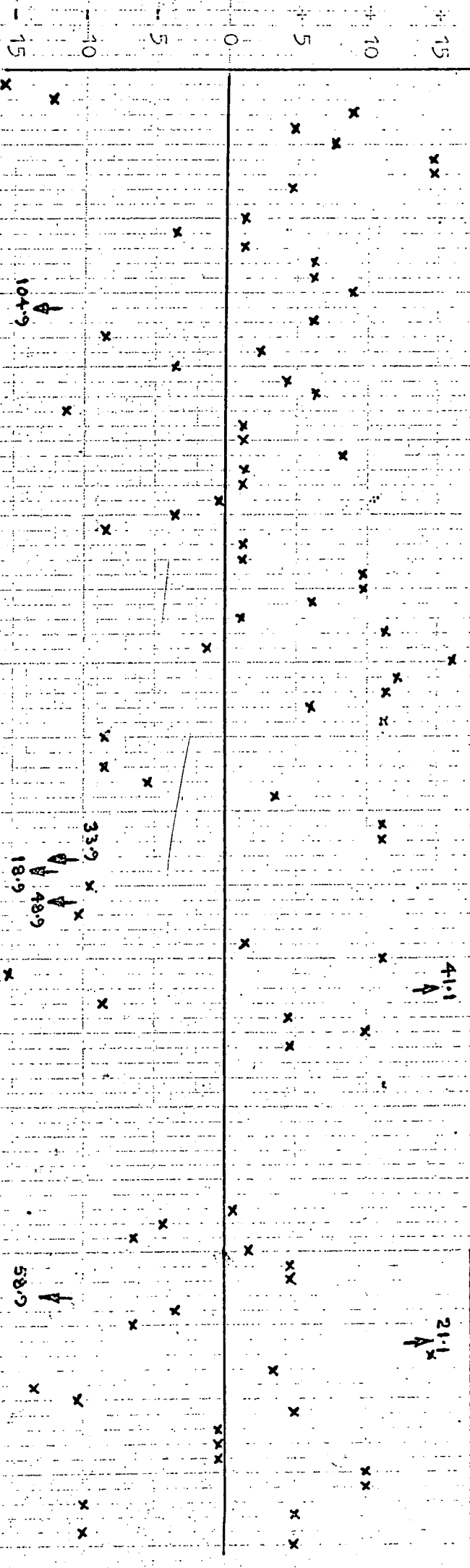
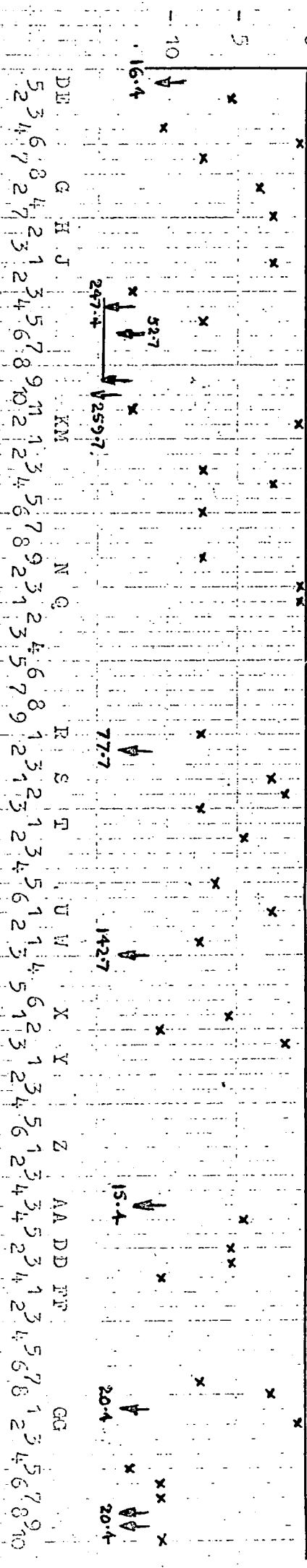
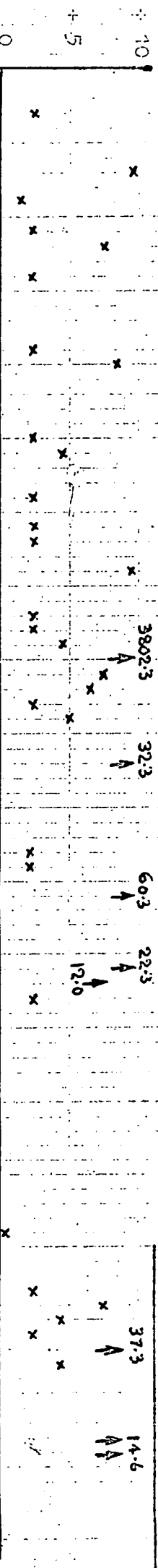
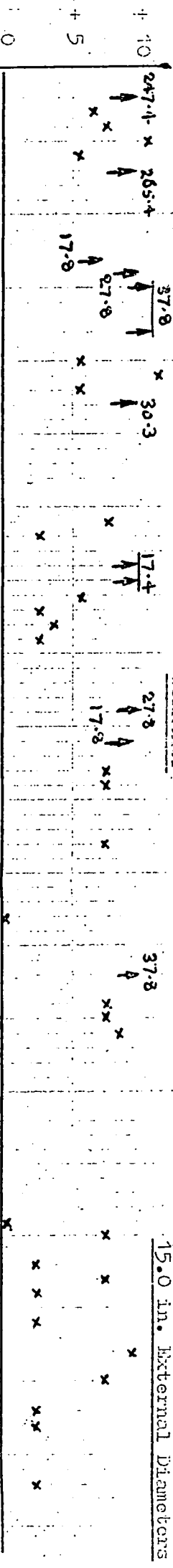

Fig. 1. Difference between Industrial Institute and CGC in diameters.



DE G H J KM N Q R S T U W X Y Z AA DD FF GG

5 2 3 4 5 6 7 8 9 10 11 12 13 14 15 16 17 18 19 20 21 22 23 24 25 26 27 28 29 30 31 32 33 34 35 36 37 38 39 40 41 42 43 44 45 46 47 48 49 50

13.0 in. Internal Diameters

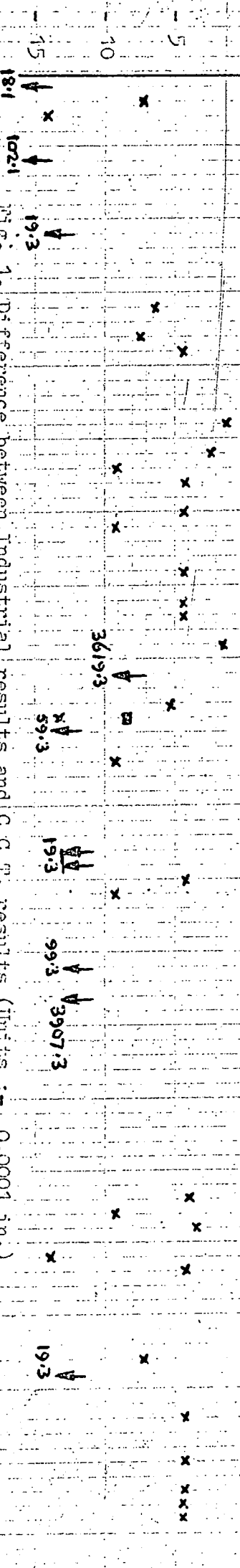
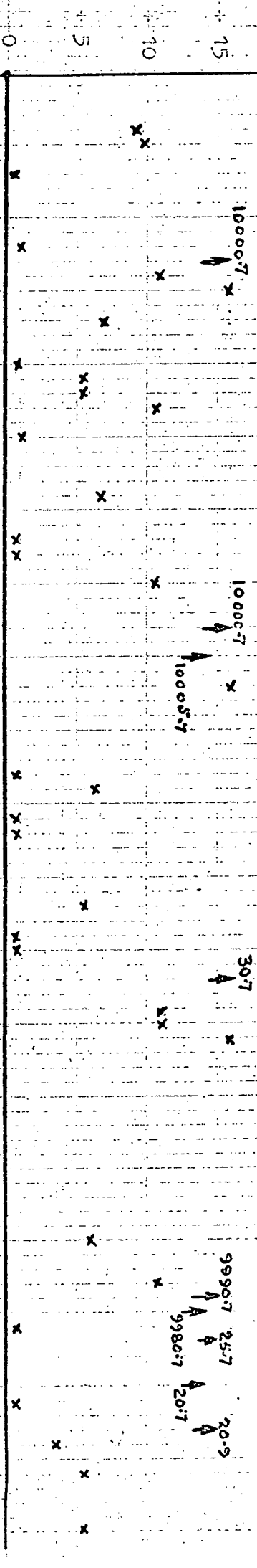

Difference between Industrial results and C.G.P. results (Units: - 0.0001 in.)

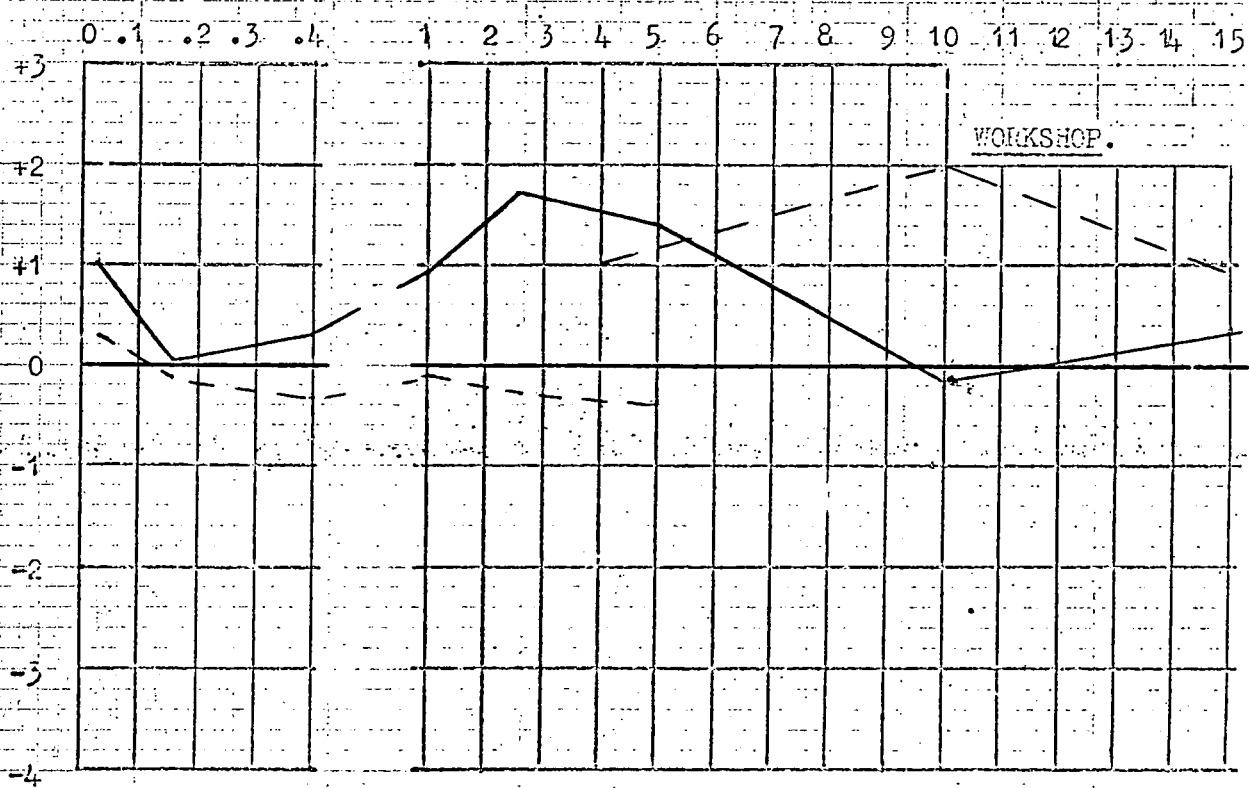
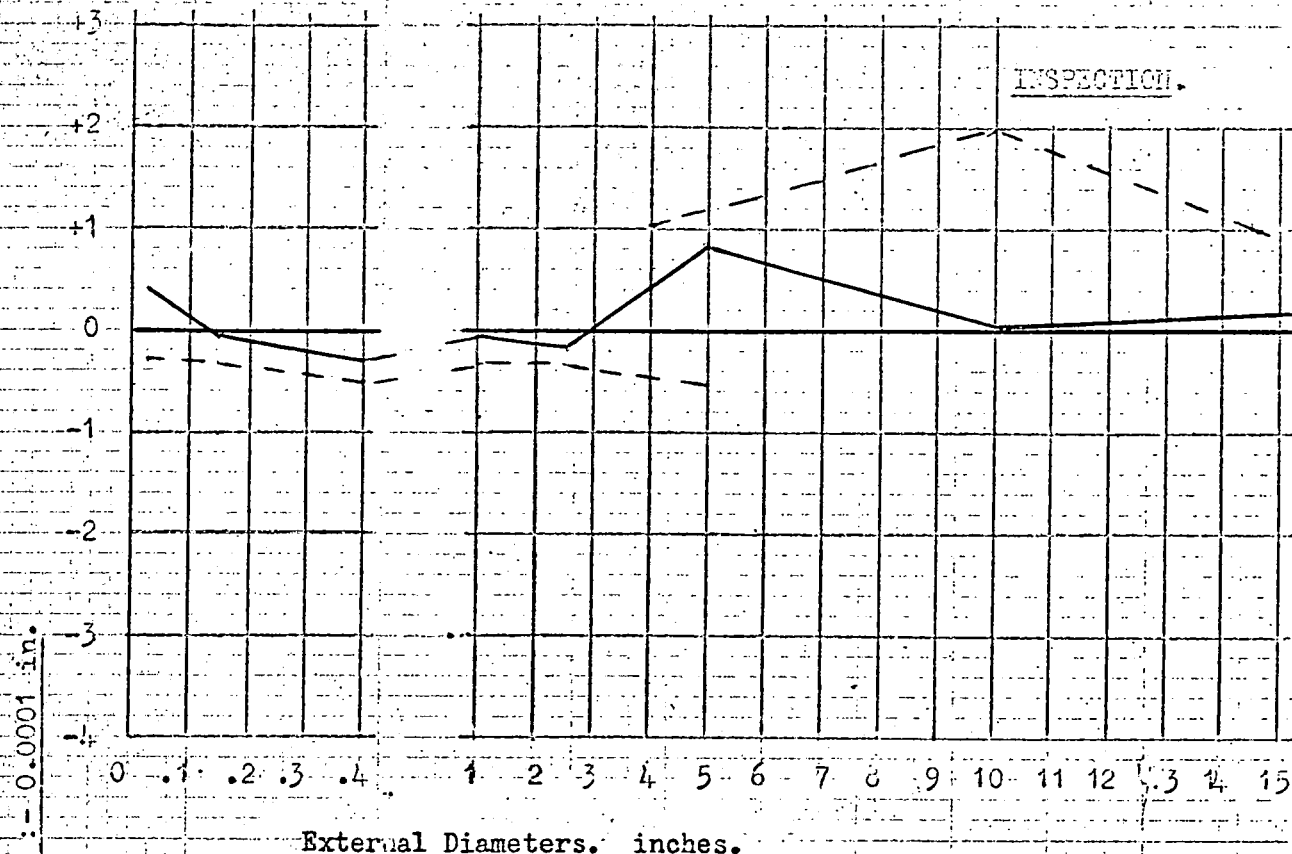

Fig. 2. Algebraic Mean of Industrial Errors.

C.C.T.

N.P.L.

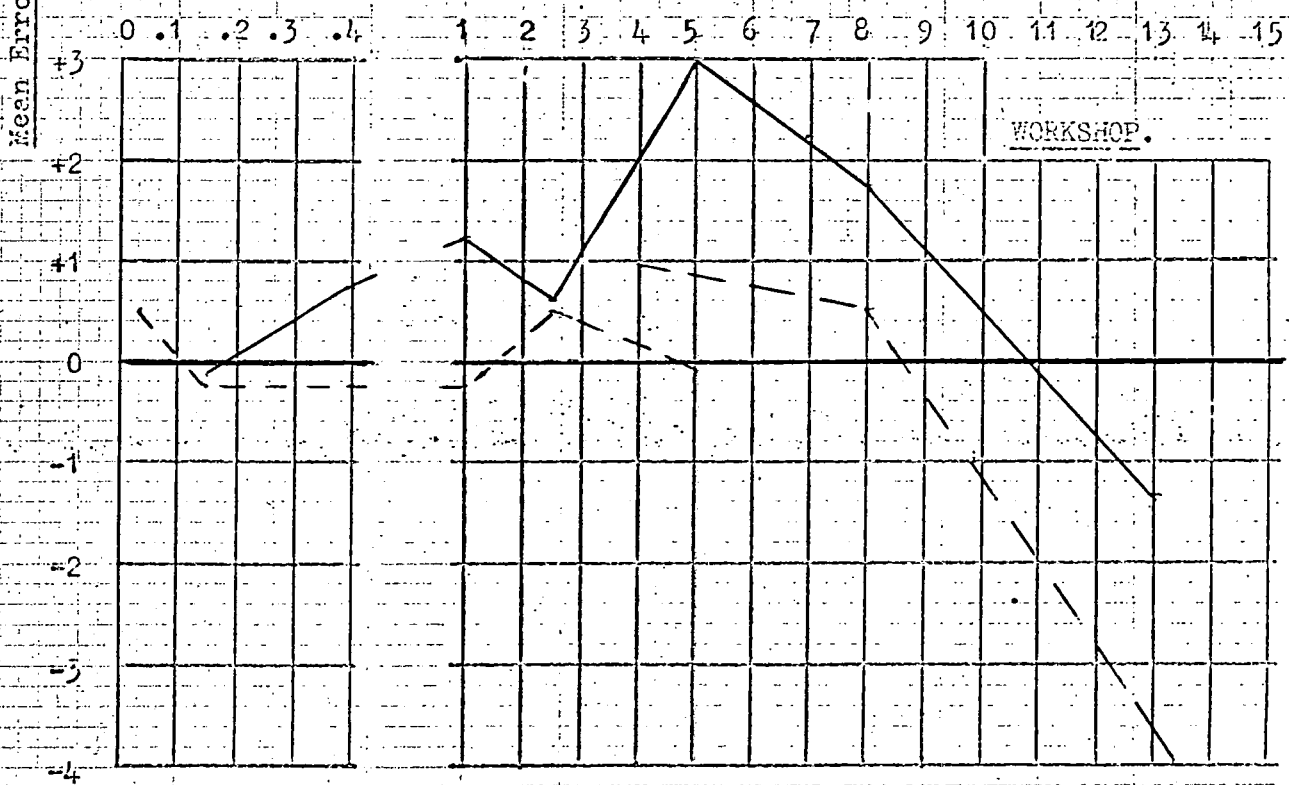
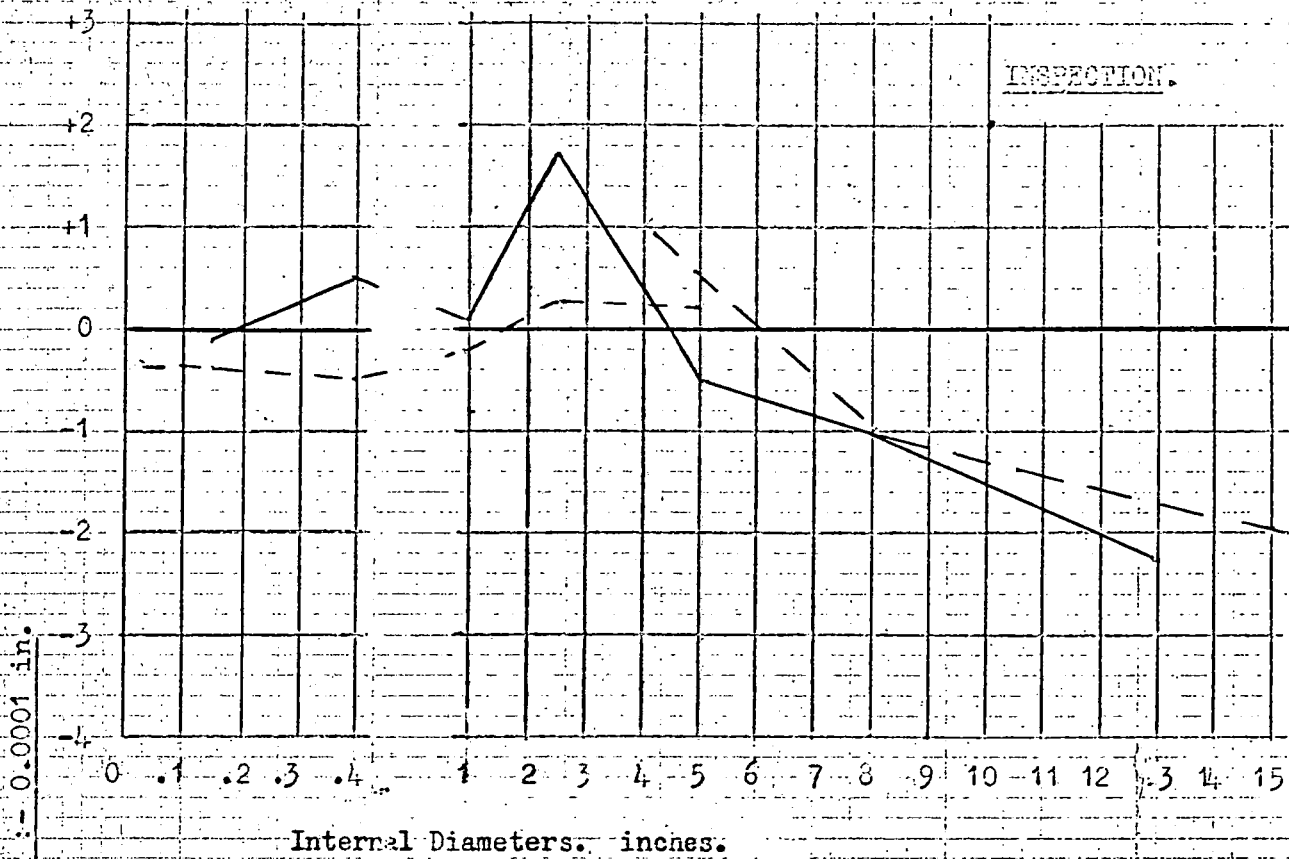

Fig. 2. Algebraic Mean of Industrial Errors. (ctd.)

External Diameters. Code letter (a).

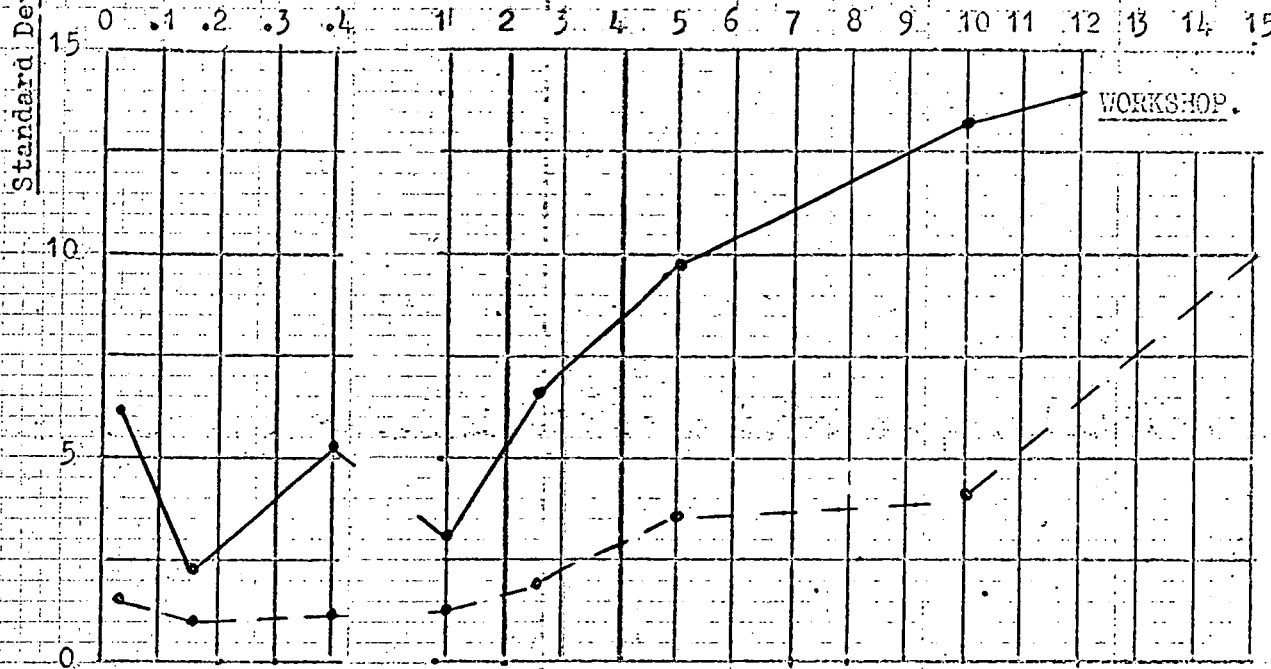
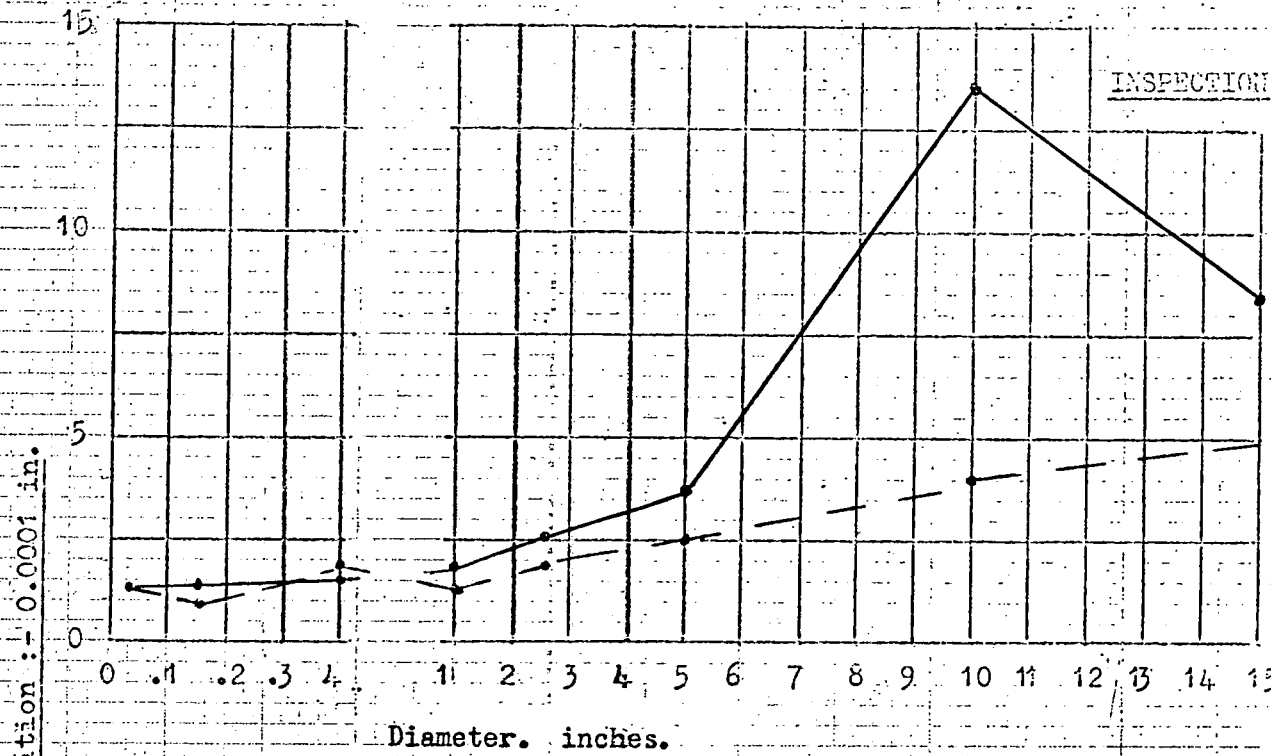

Fig. 3. Standard Deviation of Industrial Errors.

————— C.C.T.

————— N.P.L.

External Diameters. Code letter (b).

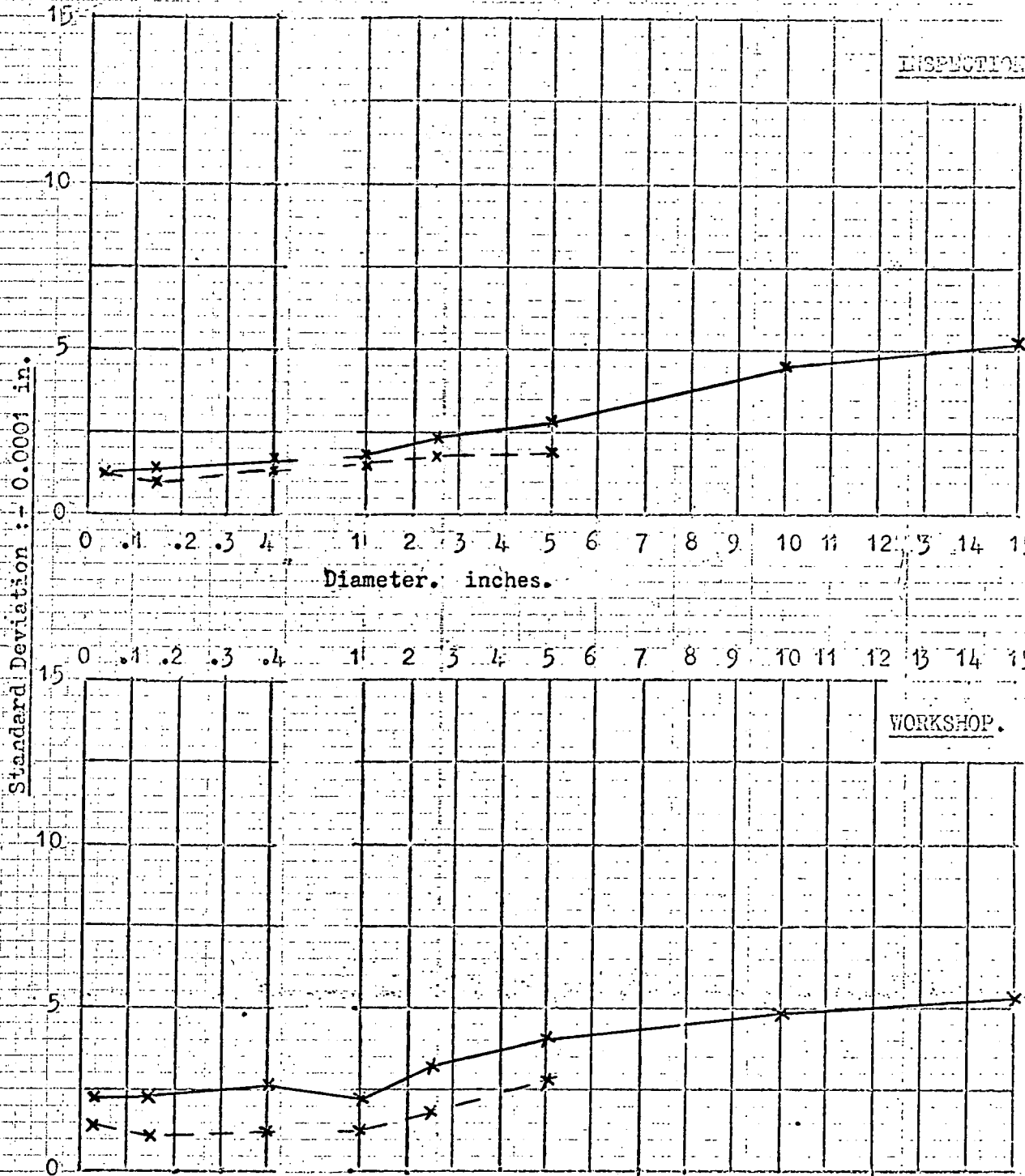

Fig. 3. Standard Deviation of Industrial Errors.

————— C.C.T.

- - - - - N.P.L.

Internal Diameters. Code letter (b).

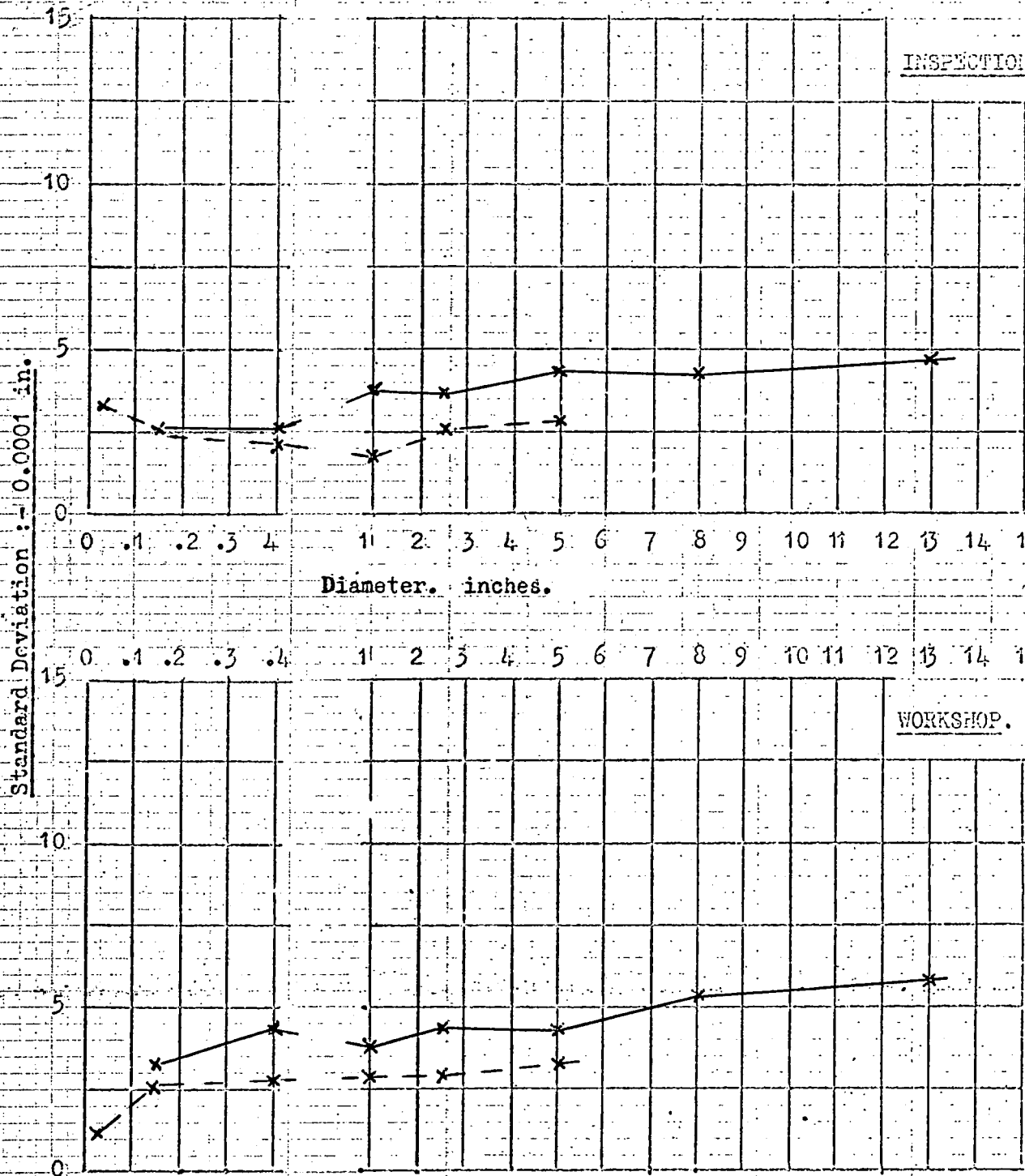

Fig.3. Standard Deviation of Industrial Errors.

———— C.C.T.

----- N.P.L.

External Diameters. Code letter (c).

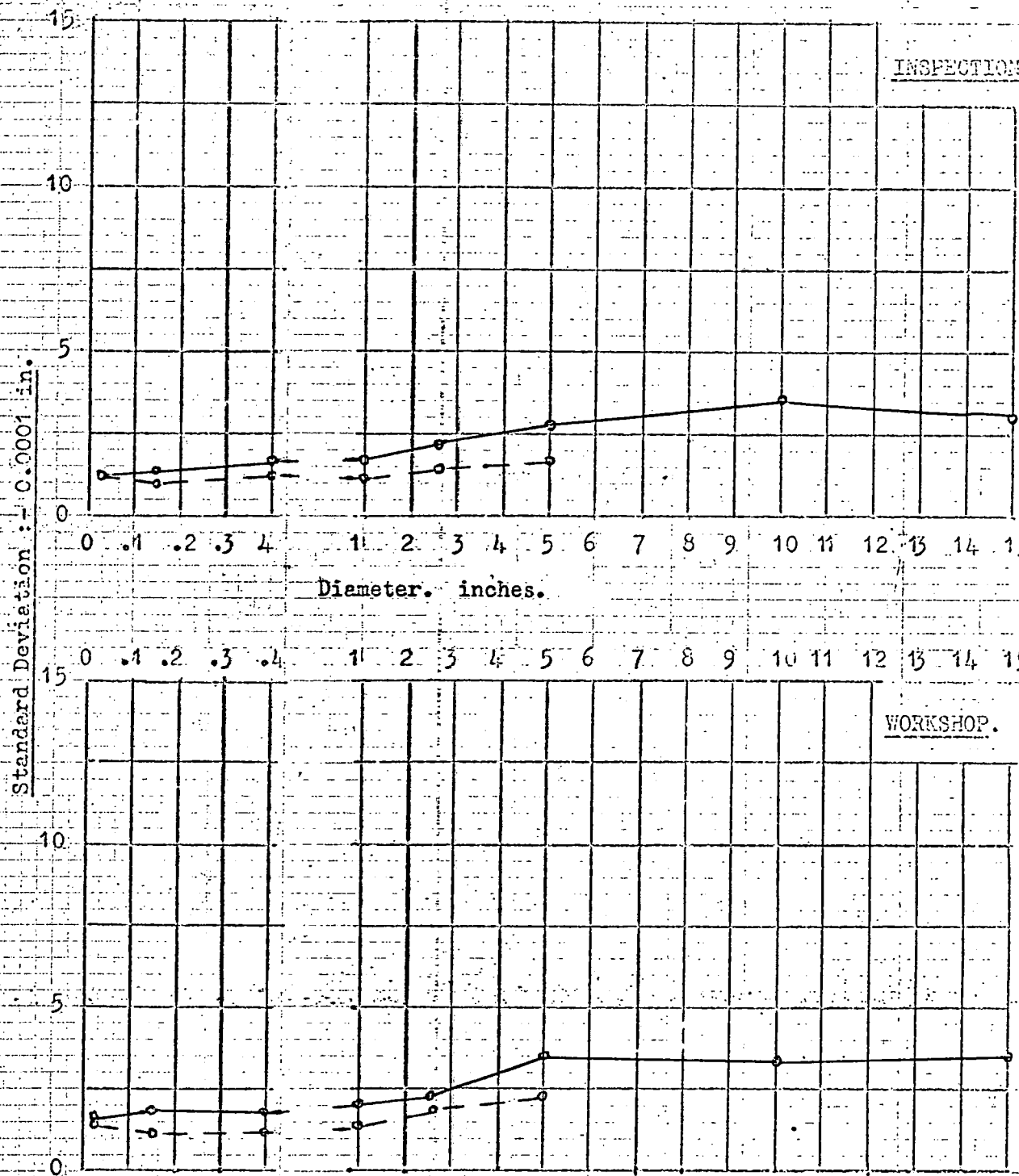

Fig. 3. Standard Deviation of Industrial Errors.

———— C.C.T.

- - - - - N.P.L.

Internal Diameters. Code letter (c).

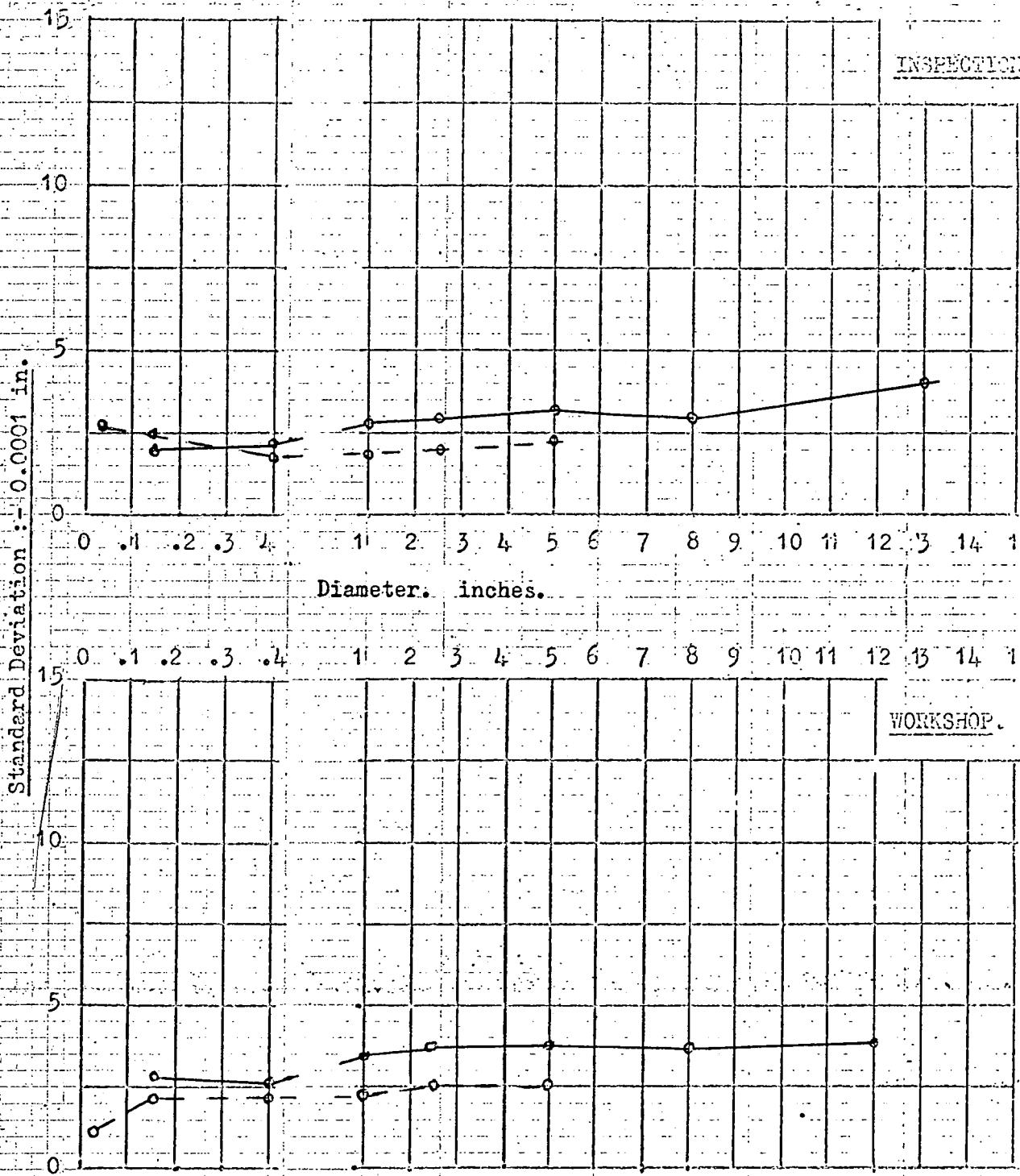

Fig. 3. Standard Deviation of Industrial Errors.

— C.C.T.

- - - N.P.L.

External Diameters. Code letter (d).

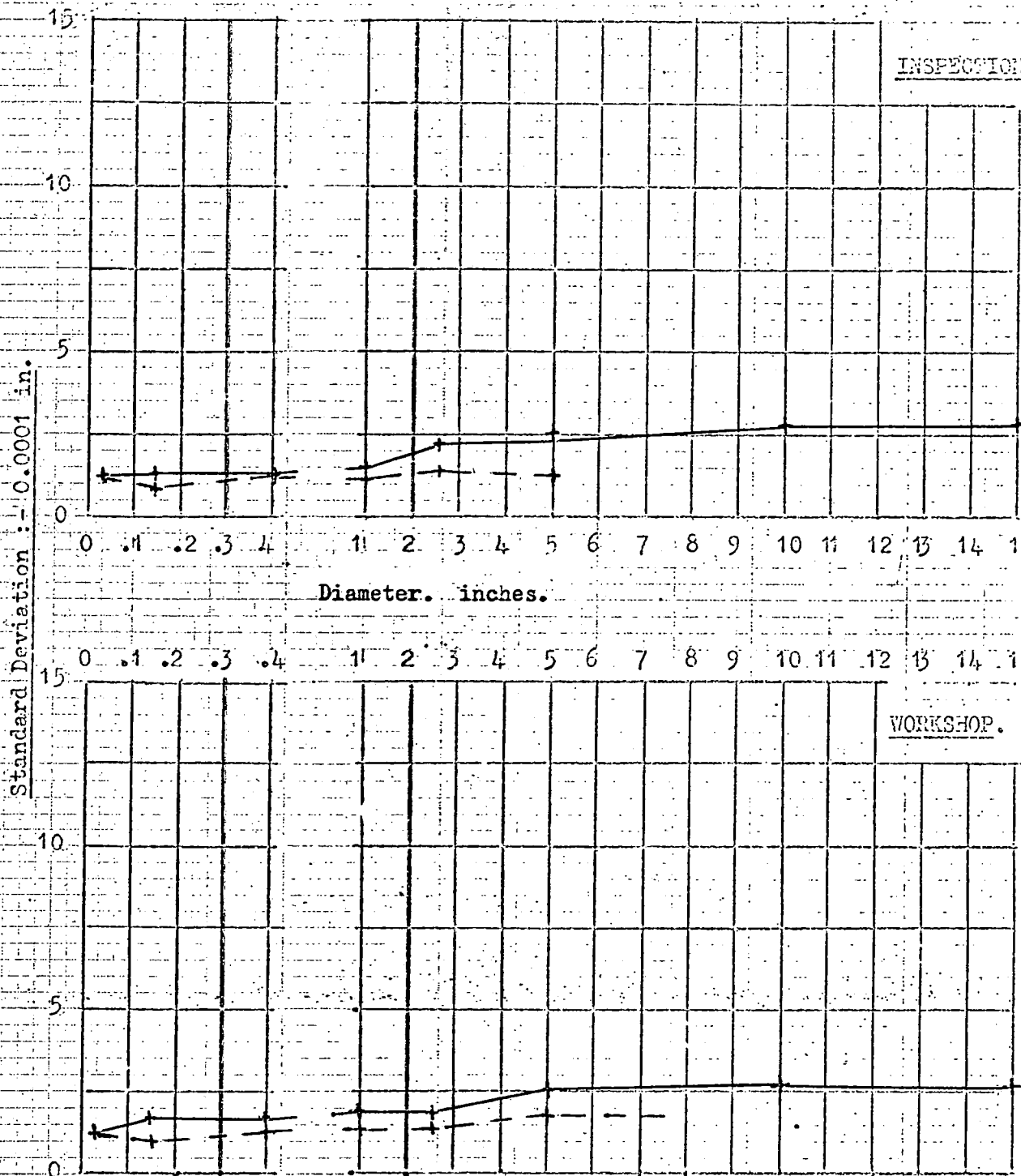

Fig. 3. Standard Deviation of Industrial Errors.

— C.C.T.

- - - N.P.L.

Internal Diameters. Code letter (d).

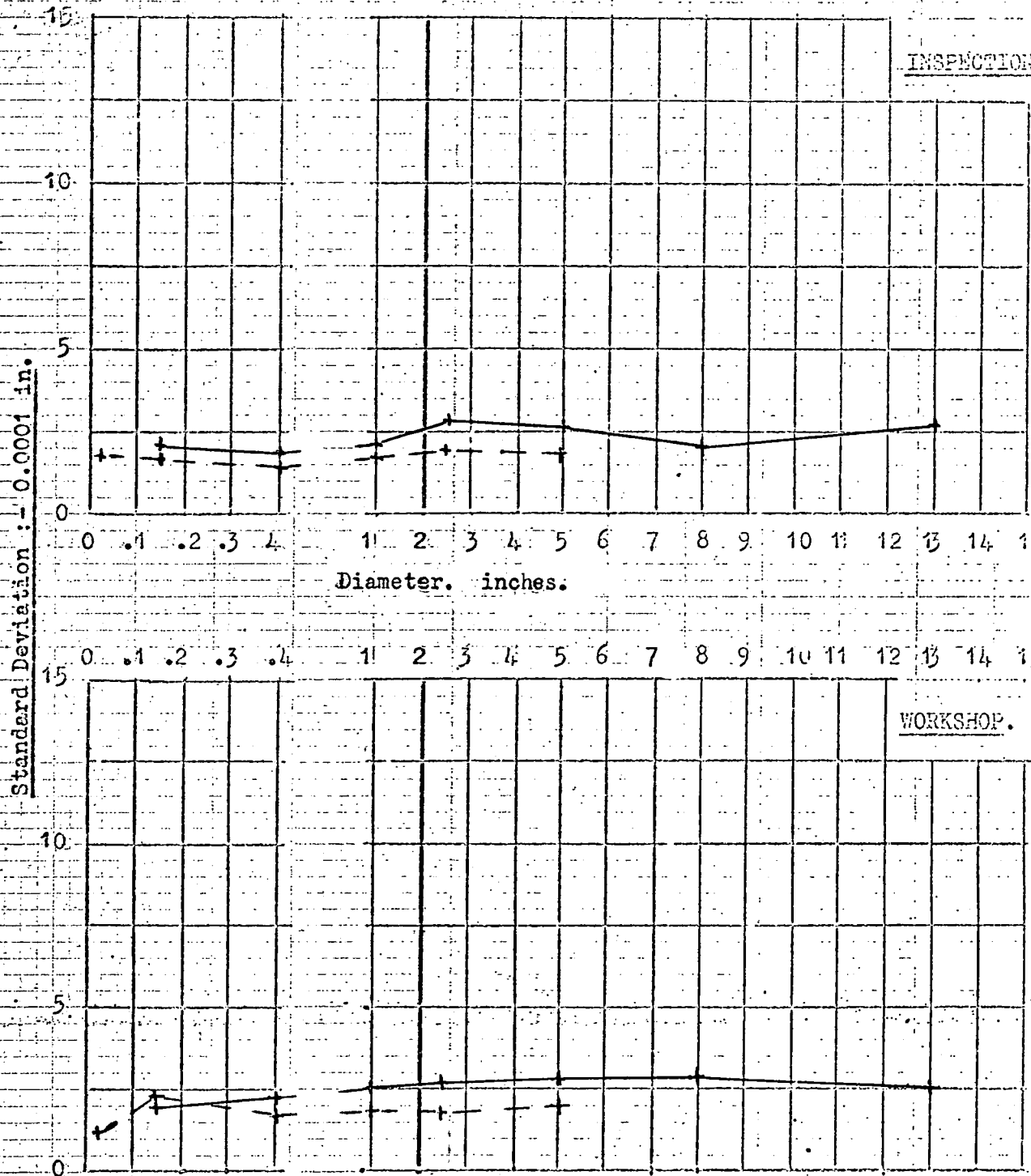

Fig. 3. Standard Deviation of Industrial Errors.

———— C.C.T.

----- N.P.L.

INTERNAL DIAMETERS.

INSPECTION.

WORKSHOP.

METHOD.	INSPECTION.						WORKSHOP.							
	0.15	0.4	1.0	2.5	5.0	8.0	13.0	0.15	0.4	1.0	2.5	5.0	8.0	13.0
Inside micrometer set with external micrometer.														
Inside micrometer set with slip gauges.														
Inside micrometer.														
Inside micrometer set with shop standards.														
Paper gauges & outside micrometer.														
Inside caliper & external micrometer.														
Inside micrometer set with vernier caliper.														
Vernier caliper set with external micrometer														
Vernier caliper.														
Telescopic gauge & external micrometer.														
Ball gauge & external micrometer.														
Inside micrometer & measuring machine.														
Horizontal comparator & slip gauges.														

Fig. 4. Continued.

METHOD.	INTERNAL DIAMETERS.													
	INSPECTION.					WORKSHOP.								
	0.15	0.4	1.0	2.5	5.0	8.0	13.0	0.15	0.4	1.0	2.5	5.0	8.0	13.0
Jig boring machine & slip gauges.														
Dial gauge, slip gauges & height micrometer.														
Slip gauges & attachments.														
Bore comparator & slip gauges,														
Bore comparator & external micrometer.														
Drill shank & external micrometer.														
Plug gauge & external micrometer.														
Plug gauge, comparator & slip gauges.														
Plug Gauge.														
Drill shank.														
Projector.														
Vernier caliper & slip gauges.														

Fig. 4. Continued.

Unit-11m.

Below
0.00002.

±.00002-41.

±.00004-61.

±.00061-81.

±.00081-110.

±.00011-16.

±.00016-21.

±.00021-31.

±.00031-51.

±.00051-110.

±.0011-16.

±.0016-21.

±.0021-51.

INSPECTION.
0.15 0.40 1.00 2.50 5.00 8.00 13.0

FOR SIDE.
0.15 0.40 1.00 2.50 5.00 8.00 13.0

INTERNAL DIAMETERS.

Fig. 5. cont'd.

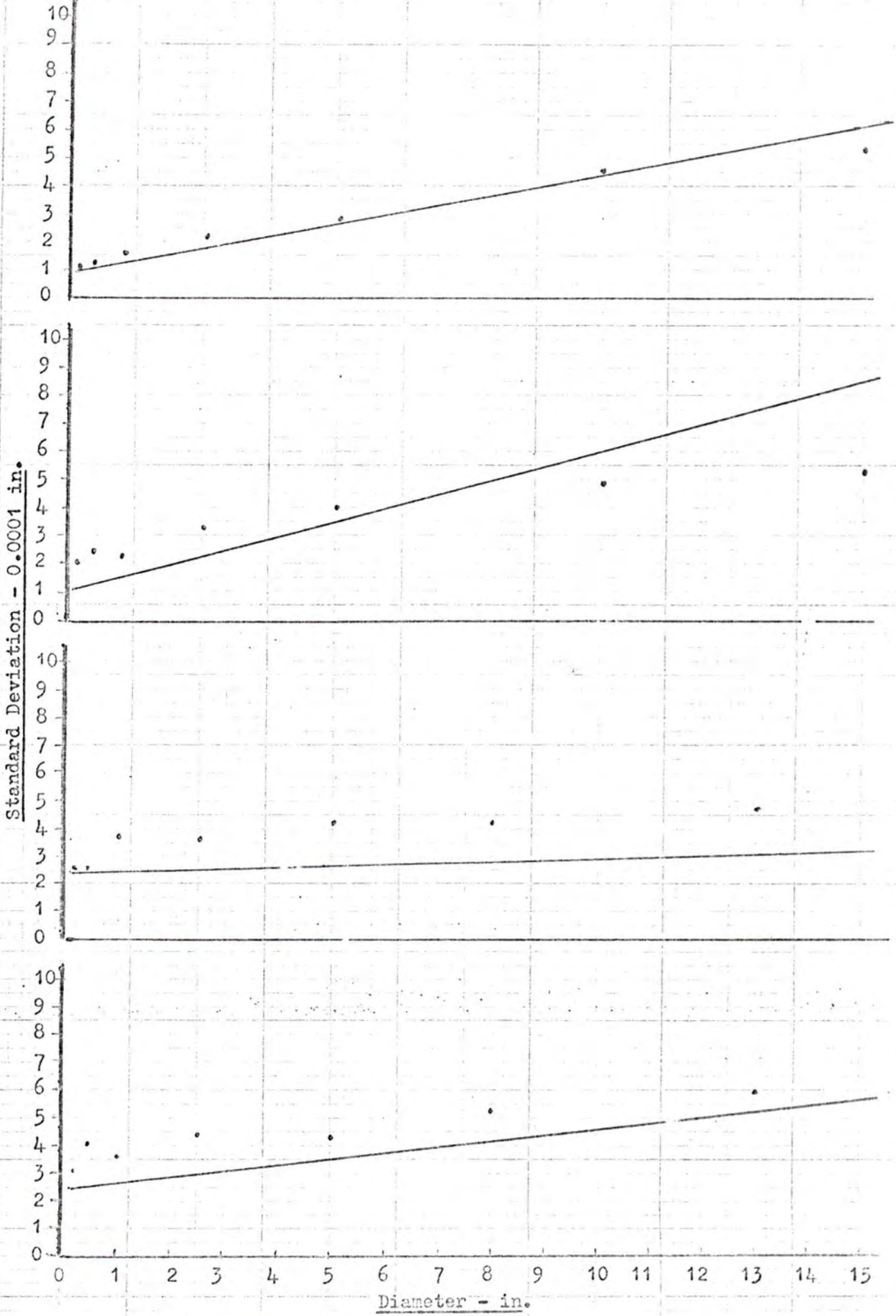

Fig. 6. Empirical Relationships between S.D. and Diameter.