

Durham E-Theses

Some ultrastructural and physiological studies of Phycomyces Sporangiohores

E. Hankinson

How to cite:

Hankinson, E. (1972) Some ultrastructural and physiological studies of *Phycomyces Sporangiohores*. Masters thesis, Durham University.

Use policy

The full-text may be used and/or reproduced, and given to third parties in any format or medium, without prior permission or charge, for personal research or study, educational, or not-for-profit purposes provided that:

- a full bibliographic reference is made to the original source
- a <https://etheses.durham.ac.uk/id/eprint/10414/> is made to the metadata record in Durham E-Theses
- the full-text is not changed in any way

The full-text must not be sold in any format or medium without the formal permission of the copyright holders.

Please consult the [full Durham E-Theses policy](#) for further details.

Some Ultrastructural and Physiological
Studies of Phycomyces Sporangiohores.

A thesis submitted by

E. Hankinson.

for the degree of Master of Science
in the University of Durham.

Department of Botany.
University of Durham.

June 1972.



C O N T E N T S

	page	
Section I	Aim of Study	1
Section II	Introduction	2
	(a) <u>Phycomyces</u> - a survey	2
	(b) Auxins and Tropic responses	4
	(c) History of Ultrastructural studies	4
Section III	Materials and Methods	7
	(a) Media and Growth vessels	7
	(b) Turntable for Geotropic Experiment and Growth Chamber for Phototropic Experiment	8
	(c) Sterilization, Inoculation and Growth Conditions	12
	(d) Spore-collection, Growth medium and culturing	13
	(e) Electron Microscopy - fixatives, resins, staining and fixing vessels	14
Section IV	Preparation of Materials for Electron Microscopy	17
	(a) Problems with fixation of <u>Phycomyces</u>	17
	(b) Dehydration	19
	(c) Embedding procedures investigated	20
	(d) Sectioning	26
Section V	Protoplasmic Streaming	27
	(a) Historical	27
	(b) Protoplasmic streaming in <u>Phycomyces</u>	30

	page
(c) Observations on Streaming in <u>Phycomyces</u>	30
(d) Organelle distribution and Streaming	36
(e) Electron microscopy	42
(f) Streaming and Secondary Wall Development	45
Section VI Geoperception in <u>Phycomyces</u> Sporangiophores	
(a) Historical	48
(b) Investigations for Sensory Apparatus	50
(c) Results of Light Microscope and Electron Microscope Examination	58
Section VII Photoreception in <u>Phycomyces</u>	71
(a) Historical	71
(b) The possible photoreceptor	73
(c) Electron microscope Investigations for the Photoreceptor	76
(d) Results of Investigations	77
Section VIII Sporangium Development and Spore Germination	
(a) Review of previous work on Sporangium Development	80
(b) Sporangium development	83
(c) Preparation of Material for Electron Microscopy	84
(d) Results of Electron Microscope Investigations	85
(e) Germination of Spores	103

A B S T R A C T

Although the Phycomyces sporangiophore has been the object of numerous physiological investigations little is known of its ultrastructure or of the changes that occur within it during growth and development. This is partly due to the failure of some workers to obtain satisfactory fixation of the sporangiophore for ultrastructural investigations.

Investigations were made for suitable fixation procedures which might help to elucidate the fine structure of the sporangiophore during growth and development. Using the fixation procedures developed, long microfilaments lying almost parallel to the long axis of the sporangiophore and closely associated with mitochondria were revealed. These microfilaments probably determine the path along which the mitochondria move and may account for the multistriate streaming of organelles as seen in the phase contrast microscope. Investigations for a discrete gravity receptor proved negative but did reveal an upward displacement of the large central vacuole concurrent with the development of a geotropic curvature. I was not able to find any organelle which might function as a photoreceptor.

The ultrastructural changes occurring during the development of the sporangium and germination of the spores are described.

Section I

Aim of Study.

Although Phycomyces blakesleeanus has been the object of numerous investigations and much is known about its physiology, biochemistry, genetics and habits, there remains several phenomena still unexplained, an explanation of which might be assisted if a more detailed knowledge of the fine structure were available.

It was the aim of this study:-

1. To investigate the possibilities of examining the vegetative structures of Phycomyces under the electron microscope. (Several attempts have been made but in all cases considerable difficulty has been experienced in the preparation of the material prior to examination.)
2. To determine if such phenomena as protoplasmic streaming, geoperception and photoperception of the sporangiophore had any basis in recognisable ultrastructural features associated with, and perhaps responsible for, the observed behaviour.
3. To investigate the development and maturation of the sporangia and the germination of the spores.

The investigation was, therefore, essentially a study by electron microscopy and much of the evidence appears in the electron micrographs.



Section II

Introduction.

IIa Phycomyces - A Survey

Phycomyces blakesleeanus belongs to the fungal class Zygomycetes, members of which are characterised by the production of non-motile vegetative spores lacking flagella on a mycelium that is almost completely without septa

The genus Phycomyces was first created in 1823 by Kunze who distinguished one species only - Phycomyces nitens. At the present time there are said to be three species (Benjamin & Hesselstine 1959) recognised within the genus although only two are known to be available. These are Phycomyces blakesleeanus (Burgeff 1925) and Phycomyces nitens. Burgeff separated the species on the basis of incompatibility. Although the two interacted sexually and formed zygosporangia which germinated to produce sporangia the spores were sterile.

The organism has been of biological interest almost since its discovery. Interest was first aroused by the large, erect, cylindrical, coenocytic sporangiophores which may grow to a height of 10 cm or more, and their striking phototropism, and later by the discovery of self incompatibility by Blakeslee (1904) and the requirement of Phycomyces for vitamin B₁ by Schopfer (1934) and Burgeff (1934).

Each sporangiophore bears a single spherical sporangium which may be up to five times the diameter of the supporting sporangiophore.

Many investigations have been made into the mechanism of sporangiophore growth of this fungus (Castle 1942, 1958, 1959) and particularly into the spiral growth so characteristic of the Stage IV sporangiophores. About 2-3 hours after the completion of sporangium development, growth in height of the sporangiophore, which ceases during sporangium formation, is resumed and within a few hours a steady growth of about 3 mm per hour is attained and may continue for several hours. Growth of the sporangiophore is limited to a growth zone which occupies the first 2-3 mm of the sporangiophore below

the base of the sporangium. Growth is not uniform throughout the zone, but reaches a maximum at about 0.3 mm below the sporangium swelling and declines to zero at the base, about 2 mm below the sporangium base (Castle 1958). During the growth of a mature sporangiophore - Stage IV (Castle 1942) the sporangium and each section of the growth zone rotates around the vertical axis, the rotational velocity being fastest for the sporangium and decreasing to zero at the base of the growing region. This rotation is at first anticlockwise (Z helix, Raelofsen 1959) but later changes to a clockwise direction (S helix, Raelofsen 1959)(Castle 1942). Growth within the zone can be considered to be a measure of the rate of synthesis of wall material and its intersusception between the previously existing microfibrils. It is believed by some workers that the spiral growth of the sporangiophore reflects the submicroscopic fibrillar anatomy of the sporangiophore wall (Hawker, 1965)

The sporangiophore is sensitive to light - a response first discovered and extensively studied by Blaauw in 1909, 1914, 1915 and 1918 (Bergman et al 1969) and to gravity, the most detailed study of which has been made by Dennison (1959). It has more recently been shown to respond to humidity changes and to an imposed stretching force. The sporangiophore also shows an avoidance response first reported by Elfving in 1881 and recently used in investigations on the habituation of the light growth response by Ortega and Gamow (1970). These various stimuli affect the rate of growth of the sporangiophore by producing either a tropic response or a temporary change in the rate of growth in the growth zone.

Below the growth zone of the sporangiophore and in the mycelial hyphae protoplasmic streaming can be readily observed by phase contrast or interference microscopy. In thin or old sporangiophores particles can be seen moving in opposite directions along a seemingly single strand of cytoplasm. The axes of these strands lie parallel to each other but often deviate by several degrees from the axis of the sporangiophore. This streaming was first described

by Oort and Raelofsen (1932) who believed it played some role in determining the spiral growth of the sporangiophore. Later studies by Pop (1938) produced conflicting evidence which led him to believe that there was no relationship between the two phenomena of streaming and spiral growth.

Iib. Auxins and Tropic Responses.

The sporangiophores of Phycomyces show three pronounced responses to external stimuli viz: a light growth response, a phototropic response and a gravitational response. So far as higher plants are concerned it is generally agreed that the growth responses to light are the result of the regulation of growth rates by auxins and similar regulators are considered to be the controlling influence of growth responses to gravity.

Banbury (1952) was unable to show any growth response to externally applied indolylacetic acid in concentrates of between 10 - 10,000 ug/ml. in the sporangiophores of Phycomyces, despite the evidence for the occurrence of this substance in fungi. He was, however, able to produce sharp curvatures in sporangiophores treated with griseoflavin paste containing 100 ug/ml. The response was the result of a change in direction of growth as a result of the application. Similar applications below the growth zone produced no apparent reaction. Despite the fact that griseoflavin is produced by several species of Penicillium and fulfills one of the criteria for a myco-auxin by its affect on the extension of chitin walled hyphae it has not been demonstrated in Phycomyces mycelium and it seemed reasonable to assume that it is not involved in the photo-responses of Phycomyces sporangiophores.

Iic. History of Ultra-Structural Studies.

Few investigators have attempted to elucidate the fine structure of this much studied fungus. The earliest ultrastructural investigation on Phycomyces was probably that of Raelofsen (1951) when he outlined the structure of the cell wall as understood from the results of experiments using double refraction and electron microscopy. This was followed in 1963 by the

results of the work of Preston on wall structure and cell growth in which he indicated that it seemed most probable that there exists a relationship between the arrangement of the chitin fibrils in the secondary cell wall, the spiral growth and the spiral streaming of the protoplasm of the Stage IV B sporangiophore.

Peat and Banbury (1967) reported on the fine structure of the growing region of the Stage I and Stage IV B sporangiophores. In this work they were able to show that in many respects the fungal hypha possessed most organelles in common with higher plants and animals - nuclei, mitochondria, vacuoles, lipid bodies, glycogen and some endoplasmic reticulum. In their micrographs the latter was comparatively sparse and unlike the condition commonly reported in higher plant and animal cells showed no obvious continuations with the membranes of the plasmalemma and nuclei. The micrographs published by Peat and Banbury showed some evidence of possible organelle distortion during preparation - nevertheless their findings agreed for the most part with those of earlier workers with fungal material and summarised in "Ultrastructure of Fungi", Bracker (1967) and "Fine Structure of Fungi", Hawker (1965).

However Peat and Banbury (1967) were not able to find any ultrastructural basis for the spiral streaming of the protoplasm or the striking tropic responses of the sporangiophore to light and gravity.

A new organelle not observed by Peat and Banbury is the autophagic vesicle (Thornton 1968). Such vesicles were reported by that author as occurring in large numbers below the nuclear zone of the Stage I sporangiophore where they were often seen to contain cytoplasmic constituents in various stages of disintegration. It was suggested that these vesicles, which start out as small cisternae, coalesce around the portion of the cytoplasm to be disposed of, so engulfing it, and finally discharge the degraded contents into the central vacuole. Having made their first appearance in the swollen hyphal primordia of very young sporangiophores, the vesicles were reported as persisting throughout the development of the sporangiophore, and to function after sporulation and maturation of the sporangium. (In view of the immense difficulty experienced by myself and other workers in obtaining satisfactory Gluteraldehyde post Osmium

tetroxide fixation of Phycomyces sporangiophores and my complete failure to observe comparable structures, although vesicles which coalesce with the central vacuole have been observed in material either similarly fixed and embedded in Methacrylate (Mohr & Cocking 1968), or fixed in potassium permanganate and embedded in Araldite, I remain somewhat unconvinced of the existence of autophagic vesicles).

Investigations of the fine structure of Phycomyces have been slow because of the inherent properties of the cuticle and cell wall which make preparation of the material for electron microscopical examination difficult; yet a knowledge of the ultrastructural features, particularly of the sporangiophore, might well assist in explaining some of the phenomena which are so characteristic of this fungus and which have so far remained inexplicable in terms of light microscope observations and sensory physiology.

When beginning investigations on the ultrastructure of Phycomyces blakesleeianus it was first essential to develop a technique of material preparation which would result in the minimum disruption in shape and distribution and structure of the constituent organelles of this extremely large cell.

SECTION III

MATERIALS AND METHODS.

Source of Strain

Phycomyces blakesleeenans plus and minus strains were obtained from C.B.S. Baarn and were the same as those used by Peat and Banbury (1967)

IIIa. Media and Growth Vessels

Culture medium. The fungus was grown on plates or solid slopes of 2% malt agar throughout the investigation.

The medium was made up as follows:-

Malt-Agar Medium

Malt extract	20.0 grammes
Distilled water	1000.0 cm ³
Agar	20.0 grammes

Two other media were tried at the beginning of the work but as the growth on these substrates was not as good as that on the 2% malt agar, they were abandoned. These media were a malt extract-glucose agar and a malt extract-glucose-peptone agar.

Malt extract-glucose agar

Malt extract	20.0 grammes
Glucose	20.0 grammes
Agar	20.0 grammes
Distilled water	1000.0 cm ³

Malt extract-glucose-peptone agar

Malt extract	20.0 grammes
Glucose	20.0 grammes
Peptone	0.5 grammes
Agar	20.0 grammes
Distilled Water	1000.0 cm ³

The growth was particularly poor on the malt extract-glucose-peptone medium, the fungus producing a sparse mycelium and a poor crop of sporangiophores.

Culture vessels.

(a) Petri dish cultures. For routine work the fungus was grown in sterile plastic petri-dishes, diameter 8.8 cm. These were kept in sterile glass petri dish tops, diameter 10.1 cm., and covered with sterile crystallizing dishes, diameter 9.0 cm. and height 4.6 cm., (fig 1).

(b) Oxoid cap cultures were used when cultures were to be centrifuged. Small oxoid caps, diameter 2.5 cm. height 2.5 cm, held about 12.5 ml. of culture medium. Eight culture vessels could be placed on a sterile glass petri-dish top, diameter 10.1 cm., and covered with a sterile crystallizing dish, diameter 9.0 cm. and height 4.6 cm., until growth of the sporangiophores was sufficient for use in the centrifuge. (figs. 2a and b)

(c) Protective caps. Before use, the oxoid cap cultures were covered with Morton Closure Caps, diameter 2.7 cm. and height 3.8 cm., (fig 3).

IIIb.1) Turntable for Geotropic Experiments

A turntable of tufnol, 38 cm. diameter and 3 cm. deep, was made to fit a slow speed M.S.E. centrifuge.

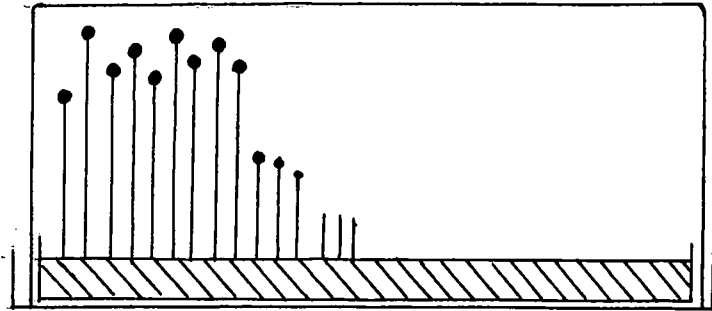

Fig 1. Culture vessel in which material used to investigate protoplasmic streaming and sporangium development was grown.

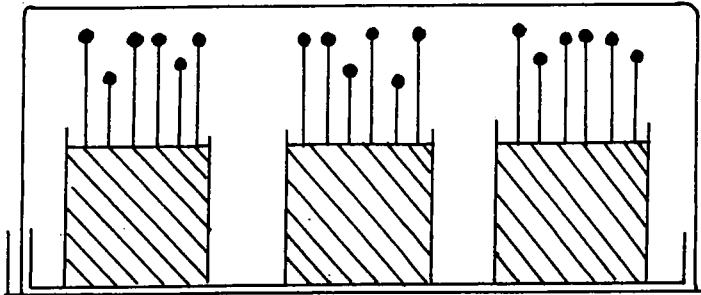

Fig 2a. Vessels in which material was grown for use in geotropic experiment.

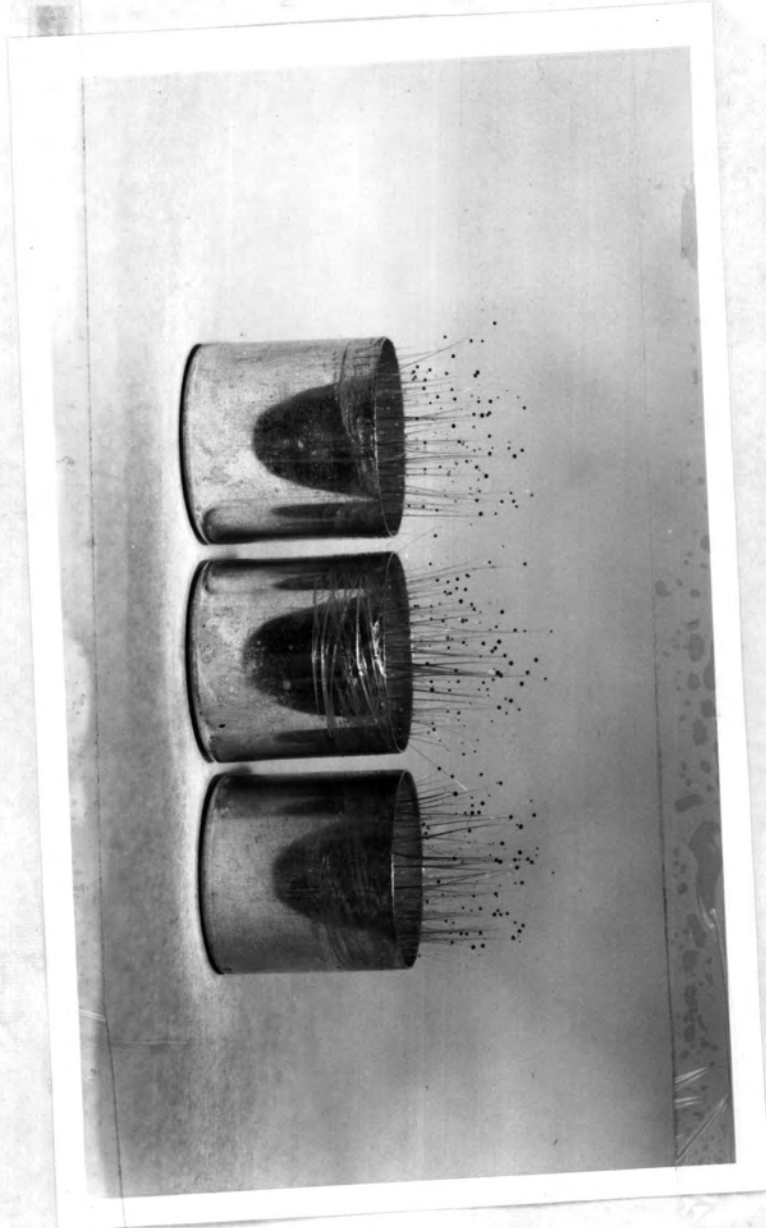

Fig 2b Culture vessels used on M.S.E. Centrifuge Turntable

BRADY UNIVERSITY
LIBRARY
31 OCT 1972
BRADY UNIVERSITY
LIBRARY

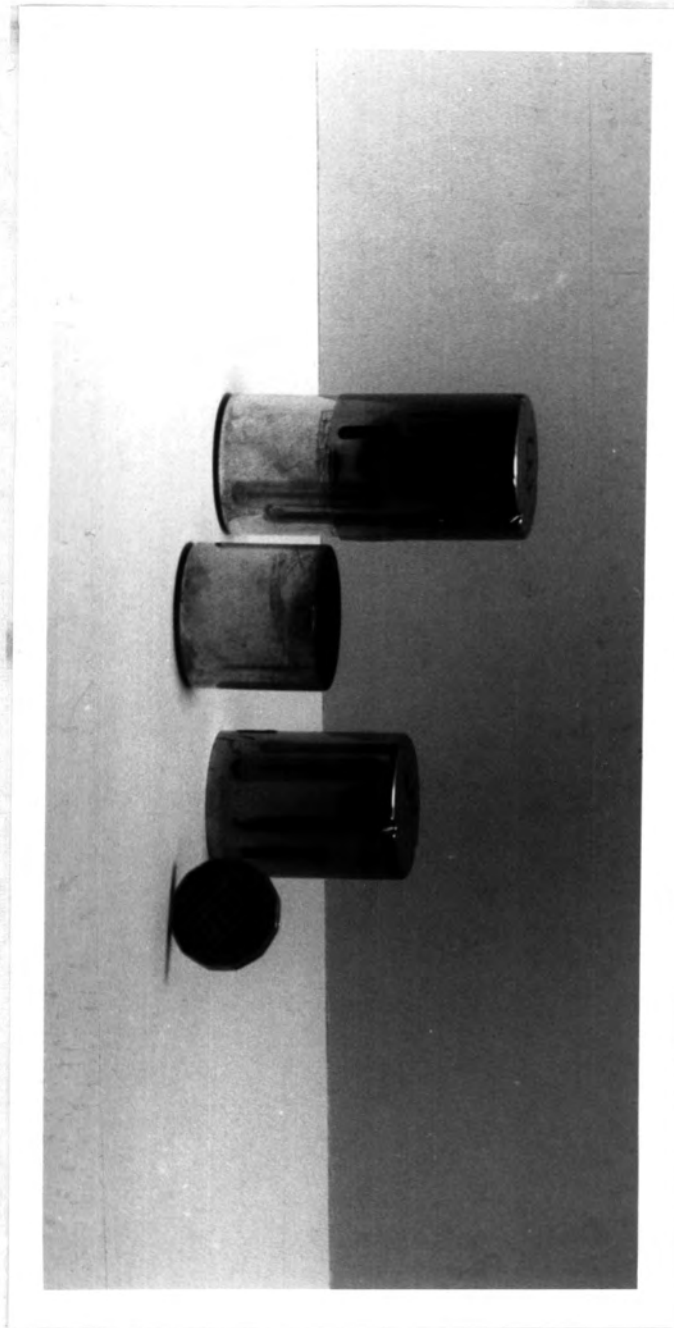

Fig 3 Culture vessel. and Morton Closure Cap

YERKES UNIVERSITY
CHICAGO
31 OCT 1972
SECTION
LIBRARY

This was bored with holes, 2.8 cm. in diameter and 2.2 cm. deep, into which the oxid cap cultures could be firmly fitted. The holes were with their centres 3.81 cm., 5.08 cm., 7.62 cm., 10.16 cm., 11.43 cm., and 15.24 cm. from the centre of rotation of the turntable (Fig. 4)

2) Growth Chamber for Phototropic Experiment

A box 51cm X 55cm X 55cm was made light proof by coating both the inside and outside with black paint. It was fitted with two 3 watt bulbs so that two opposite light beams each made an angle of approximately 45° with the centre of the chamber floor. The two beams were of closely matched intensity and when necessary the right beam could be cut off to produce asymmetrical illumination of vertical sporangiophores placed in the centre of the chamber floor. The front of the box was covered with black polythene sheeting.

IIIc. Sterilization and Inoculating procedure

The culture medium and vessels were sterilized by autoclaving at a pressure of 15 lb./sq.in. for 15 min. The culture medium was inoculated with mycelium from a 6-7 day old culture transferred by means of a sterile platinum loop. This produced an excellent crop of sporangia about four days after inoculation.

Growth conditions.

All cultures were kept at ambient room temperature - approximately 20°C . Cultures used in geotropic experiments were transferred to the dark at the appearance of the Stage I sporangiophores and kept there until several of the sporangiophores bearing mature sporangia were 2 cm. to 2.5 cm. tall.



Fig. 4 MSE centrifuge with turntable made to take
oxid cap. culture vessels.

Cultures used in phototropic experiments were subjected to continual illumination from a diffuse light at 60 cm. distance until several sporangiophores bearing mature sporangia were 2 cm. to 2.5 cm. tall.

IIIId. Collection of Spores

Spores were collected from 8-9 day old plate cultures as these produced the greatest number of viable spores. The plates were flooded with 3 cm³ of sterile distilled water drained and rinsed with another 3 cm³ of sterile distilled water. The concentrated spore suspension thus obtained was diluted to 10 cm³ final volume.

Medium for Germination of Spores.

The spores were germinated on a potato extract. 30 gm. potato were macerated in 5 cm³ of sterile distilled water. This was then made up to 25 cm³ by the addition of a further 20 cm³ of sterile distilled water. The pulp was shaken vigorously for several minutes to bring as much soluble material as possible into solution. The liquid was then decanted and finally filtered through normal grade Whatman filter paper to remove the insoluble starch grains. Finally 10 cm³ of this soluble extract were added to the spore suspension in a petri dish.

Culturing of Spores.

The spores were cultured in a thin film of potato extract at the bottom of a petri dish. This was incubated at 40°C for 15 minutes and

then kept at ambient room temperature. Spores taken from an 8-9 day old culture germinated in 5-6 hours.

IIIe. Electron Microscopy

1. Fixatives

(a) The most satisfactory general fixative was 2% KMnO_4 w/v (not buffered)

(b) A fixative composed of equal volumes of 4% Gluteraldehyde and 2% OsO_4 in 0.1 M cacodylate buffer gave the most satisfactory fixation of microfilaments.

Other fixatives were investigated and these are described in a section dealing with fixation

2. Resin

The only one which gave repeated satisfactory embedment of Phycomyces was TAAB Embedding Resin

This was prepared as follows:-

Resin 50 cm^3
 Dodecenylsuccinic anhydride (D.D.S.A.) 50 cm^3
 Tridimethylaminomethyl phenol
 (D.M.P./30) 0.01 cm^3 per 5 cm^3 of resin

3. Staining

The two stains most frequently used were

(a) Uranyl acetate - a 1% solution w/v made up in absolute alcohol

(b) Lead citrate - Rehold's

1.33 g $\text{Pb}(\text{NO}_3)_2$; 1.76 g Sodium citrate
 ($\text{Na}_3(\text{C}_6\text{H}_5\text{O}_7)2\text{H}_2\text{O}$) in 30 ml. water

This was shaken vigorously for 1 minute to complete conversion to lead citrate. After 30 min.

8.0 ml. of 1N. NaOH were added and the suspension diluted to 50 ml.

The sections were stained by floating them on drops of the above solution placed on wax surfaces. Potassium permanganate was used to stain some of the sections prepared from simultaneous gluteraldehyde/osmium tetroxide fixation and gave satisfactory results.

4. Vessels for fixation.

Rectangular troughs 3 in. by 1 in. by 1 in. made from microscope slides were used instead of vials for the fixation of the Stage IV B (fig. 5) sporangiophores. In these troughs the sporangiophores could be drawn down below the surface of the fixative by their base without causing deformation of the cell structure.

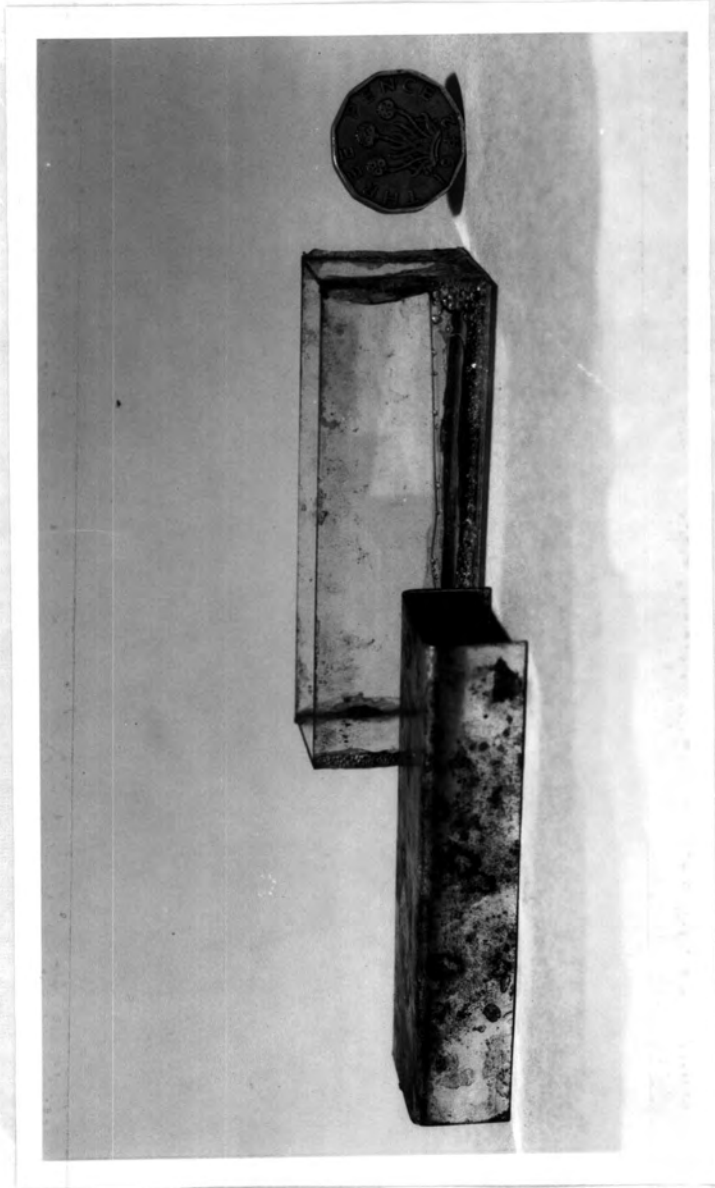

Fig 5 Trough used to prevent damage of the long
Sporangiophores during fixing

UNIVERSITY OF TORONTO
31 OCT 1972
LIBRARY

SECTION IVINVESTIGATIONS INTO THE PREPARATION OF PHYCOMYCES
FOR ELECTRON MICROSCOPYIVa. Problems pertaining to Phycomyces.

The presence of a chitinous wall surrounded by a waxy cuticle made the penetration of fixatives and embedding resin extremely difficult in all parts of the sporangiophore except the growing region and sporangiophore base. Fixatives penetrated these latter two regions fairly rapidly, but even so electron microscope examinations of these sections suggested that considerable distortion of the cell contents had occurred.

Fixation.

The following fixatives were tested on the Stage IV B sporangiophore and on sporangia (see Table I) at different stages of development. Only two fixatives were found to be satisfactory.

All fixations in gluteraldehyde were followed by post fixation in 2% aqueous OsO_4 w/v for a period of from 30 min to 2 hours at either 4°C or room temperature.

As a fixative for the sporangia, the 2% KMnO_4 w/v proved to be the most satisfactory and it was therefore decided to continue to make further studies of the development of the sporangia and germination of the spores using 2% KMnO_4 as the fixative. The periods of fixation however varied from 20 mins to 12 hours depending on the stage of development. It is recognised that using only one fixative, KMnO_4 , for work on sporangia places one

TABLE I

Fixative	Temperature	pH	Fixation period
4% Glutaraldehyde in 0.1M phosphate buffer	4°C	7.1	16 hours
" " " " " "	"	6.2	"
" " " " " "	Room temp.	4.5	"
" " containing 0.007M Calcium chloride	"	7.1	"
" " in 0.1M phosphate buffer	"	"	24 hours
" " plus 1% OsO ₄ v/v in 0.1 M phosphate buffer	"	"	12 hours
" " " " " "	"	"	40 mins.
" " " " " "	4°C	"	16 hours
2% " " 0.5M sucrose	"	6.2	"
3% " " in 0.1M phosphate buffer	"	"	"
5% " " " " " "	"	7.1	"
6% " " " " " "	"	"	"
6% " " " " " "	"	"	"
25% " " " " " "	"	"	20 hours
5% Acrolein in 0.1M phosphate buffer followed by 1% OsO ₄ w/v in 0.1M phosphate buffer	Room temp.	7.1	16 hours
1.25% Acrolein in 0.1M phosphate buffer	Room temp.	7.1	20 mins.
" " " " " "	"	"	30 mins.
50% aqueous dimethylsulphoxide (DMSO) containing 2% glutaraldehyde buffered with 0.02M S-collidine followed by OsO ₄ in veronal acetate buffer	"	"	1 hour
25% Dimethylsulphoxide plus 3.15% glutaraldehyde in 0.1M cacodylate buffer	"	"	2 hours
2% OsO ₄ w/v	"	7.4	"
2% KMnO ₄ w/v plus one part of detergent per 1000 parts of fixative	"	4.0	"
3.1% Glutaraldehyde plus 1% OsO ₄ in 0.1M phosphate buffer	"	7.0	"
1% OsO ₄	"	"	1 hour
	0°C	7.0	16 hours
	0°C	"	2 1/2 hours

at a specific disadvantage. Extra information may in general be obtained by comparing micrographs prepared from corresponding sections of material fixed by different procedures, and clear indication may be obtained concerning the destruction, or serious loss, or modification of particular components by one fixative, the same component being well preserved by another fixative. In this case however, potassium permanganate seemed to be the only fixative penetrating sufficiently to give acceptable preservation of a good proportion of the cytoplasmic components. Recognising the characteristic limitations of potassium permanganate preservation, one may still claim that some reliable information may nevertheless be obtained from a study restricted to this fixative.

Protoplasmic Streaming.

After preliminary trials it was decided to use the simultaneous gluteraldehyde, osmium tetroxide fixation with postosmication devised by Franks, Krien and Brown (1969) in further investigation of the fine structure of the mature regions of the sporangiophores.

Equal parts of ice cold 4% gluteraldehyde and 2% osmium tetroxide, both buffered with 0.1 M cacodylate to a pH 7.0, were mixed and used at once for fixation. The fixative vessel was kept in an ice bath throughout the fixation. One part of detergent per 1000 parts of fixative was added to the fixative to ensure the complete wetting of the cell walls and the complete submergence of the sporangiophores during the fixation period. The sporangiophores were fixed for one hour and then washed three times in 0.1 M cacodylate buffer for 30 minutes each, as suggested by Frank, Krien and Brown.

Washing was followed by postosmication in 1% OsO₄ in 0.1 M cacodylate buffer for 3 hours and further washing in 0.1 M cacodylate buffer for 30 minutes.

IVb. Dehydration.

During the earlier part of this study the following dehydration procedures were carried out at room temperature

Either

(1) 25%	50%	75%	and absolute alcohol	10 min.each
			Absolute alcohol, 2 changes	15 min.each
			Propylene oxide	15 min

or

(2) 25%	50%	75%	80%	90%	alcohol	10 min.each
					Absolute alcohol 2 changes	15 min.each
					Propylene oxide	15 min

These sequences caused considerable shrinkage of the highly vacuolated sporangiophores. The shrinkage was accompanied by apparent distortion of the cytoplasmic contents as seen under the light microscope. These effects were particularly noticeable at the 75% alcohol and propylene oxide stages of the dehydration procedure.

To minimise this distortion associated with long diffusion paths, the sporangiophores were cut into approximately 5 mm. lengths at the 25% alcohol stage. This procedure left an open ended unit into which substances could move freely. The 5 mm. lengths of sporangiophore were then passed through 25%, 50% 75% Absolute alcohol for 15 min. followed by a second period of 15 min. in Absolute alcohol.

Dehydration using the technique of Sitte (1962) (fig. 6) was attempted. In this technique the specimens lying in a small volume of water in a watch glass are placed on a perforated shelf in a small desiccator attached to a vacuum pump. Some alcohol and calcium chloride are placed at the bottom of the desiccator, and above the specimens is a small dish of calcium chloride.

The desiccator is evacuated until the alcohol starts to bubble vigorously and then the tap is closed. The water from the specimens slowly evaporates into the alcohol saturated atmosphere and is absorbed by the calcium chloride. It is replaced by alcohol from the atmosphere.

In my attempts the water evaporated from the specimens but its equivalent replacement by alcohol was not achieved, and the specimens showed signs of shrinkage and distortion.

IVc Embedding procedures attempted.

(1) Araldite. This resin proved entirely unsatisfactory with Phycomyces. Three embedding procedures being attempted.

(a) Conventional Method (Kay 1961, Mercer & Birbeck 1961). The material was transferred to propylene oxide for 15 minutes and then a 50/50 v/v mixture of propylene oxide and araldite in an open vessel. This was left overnight to allow the propylene oxide to evaporate so that the material would finally contain 100% araldite. Following penetration the sporangiophore lengths were then transferred to fresh 100% araldite plus 0.01 ml of accelerator per 5 ml of resin in the polymerization dishes. Polymerization was brought about by placing the resin containing the material

in a 40°C oven for 2 days and then a 60°C oven for a further 2 days.

Polymerized blocks were left to harden for a week before sectioning.

In all attempts the resin within the sporangiophore failed to harden suggesting lack of penetration of the 100% araldite plus accelerator.

(b) The method devised by Peat and Whitton - 1966.

This method attempted to achieve good penetration of the resin into difficult material over a short period of time.

Following dehydration the material was transferred into a series of mixtures of propylene oxide and araldite for a period of 1 hour in each case. The vessels were left open and the propylene oxide allowed to evaporate. The mixtures used were:

- | | | | | | | | | | | |
|-----|------|----------|----|-----------|-------|----|------|------|-------------|------|
| (a) | 20% | araldite | in | propylene | oxide | at | 60°C | for | 1 | hour |
| (b) | 50% | " | " | " | " | " | " | " | " | " |
| (c) | 70% | " | " | " | " | " | " | " | " | " |
| (d) | 100% | " | " | " | " | " | " | room | temperature | for |
| | | | | | | | | 24 | hours | |

This was followed by polymerization and hardening as before.

Again the procedure failed to give fully impregnated and hardened blocks. Although the method gave good results with Chlorogloea it has the disadvantage of producing a fluctuating concentration of araldite during impregnation.

(c) A long embedding procedure. This was attempted in the hope of achieving thorough penetration of the araldite plus accelerator. After dehydration the sporangiophore lengths were placed in a 50/50 v/v

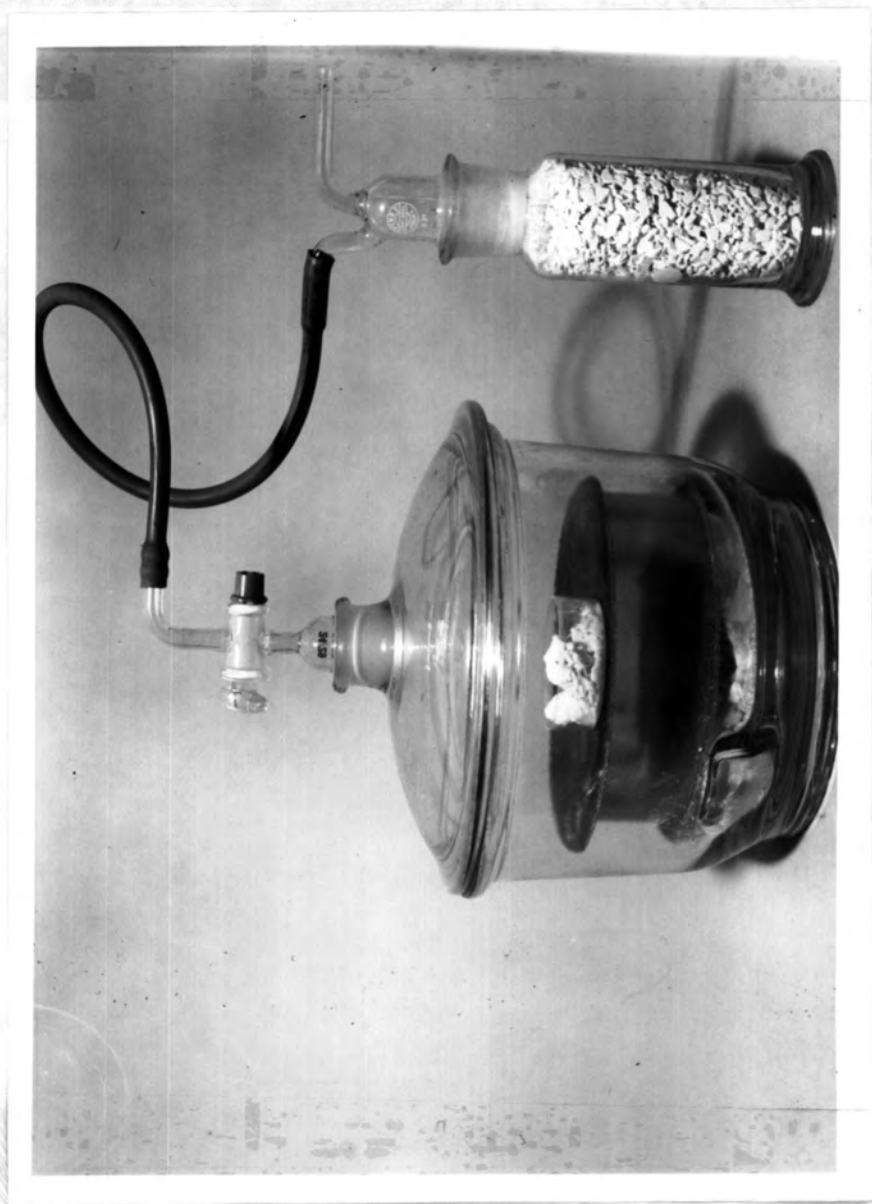

Fig 6 Dehydration Apparatus (Siffert 1962)

UNIVERSITY OF MICHIGAN
31 OCT 1972
PHYSICS LIBRARY

mixture of resin and propylene oxide for 16 hours. The caps were removed from the vials and the propylene oxide left to evaporate overnight. The material was then transferred to 100% araldite plus accelerator and left at room temperature for 2-3 days. The material was then transferred to fresh araldite plus accelerator and polymerized in a 40°C oven for 2 days followed by 2 days in a 60°C oven. The polymerized blocks were left to harden for a week before sectioning.

In almost all attempts the resin within the sporangiophores failed to harden indicating lack of penetration of the araldite plus accelerator (fig.7).
(2) Methacrylate Embedment. The methacrylate embedding procedure, for highly vacuolated and senescent cells, used by Mohr and Cocking (1968) was tried. This eliminated the need to use propylene oxide and the low viscosity of the methacrylate facilitated easy penetration.
Preparation of the Resin.

The resin was prepared by adding 3 parts styrene to 7 parts n butyl methacrylate v/v. The stabiliser of the n butyl methacrylate was removed with KOH. An equal volume of 5% KOH was added to the mixture in a separating funnel and the two thoroughly mixed and then left to separate. The brown KOH, containing the stabilizer from the n butyl methacrylate, was then run off. This procedure was repeated until the KOH layer remained clear indicating that the removal of the stabilizer was complete. The resin was then washed twice in distilled water to remove any trace of KOH. 2% benzoyl peroxide was added, together with an excess of CaCl₂, as a catalyst, to the resin. The resin was finally filtered to remove the CaCl₂. Mixtures prepared in this way could be kept for several weeks at 4°C.

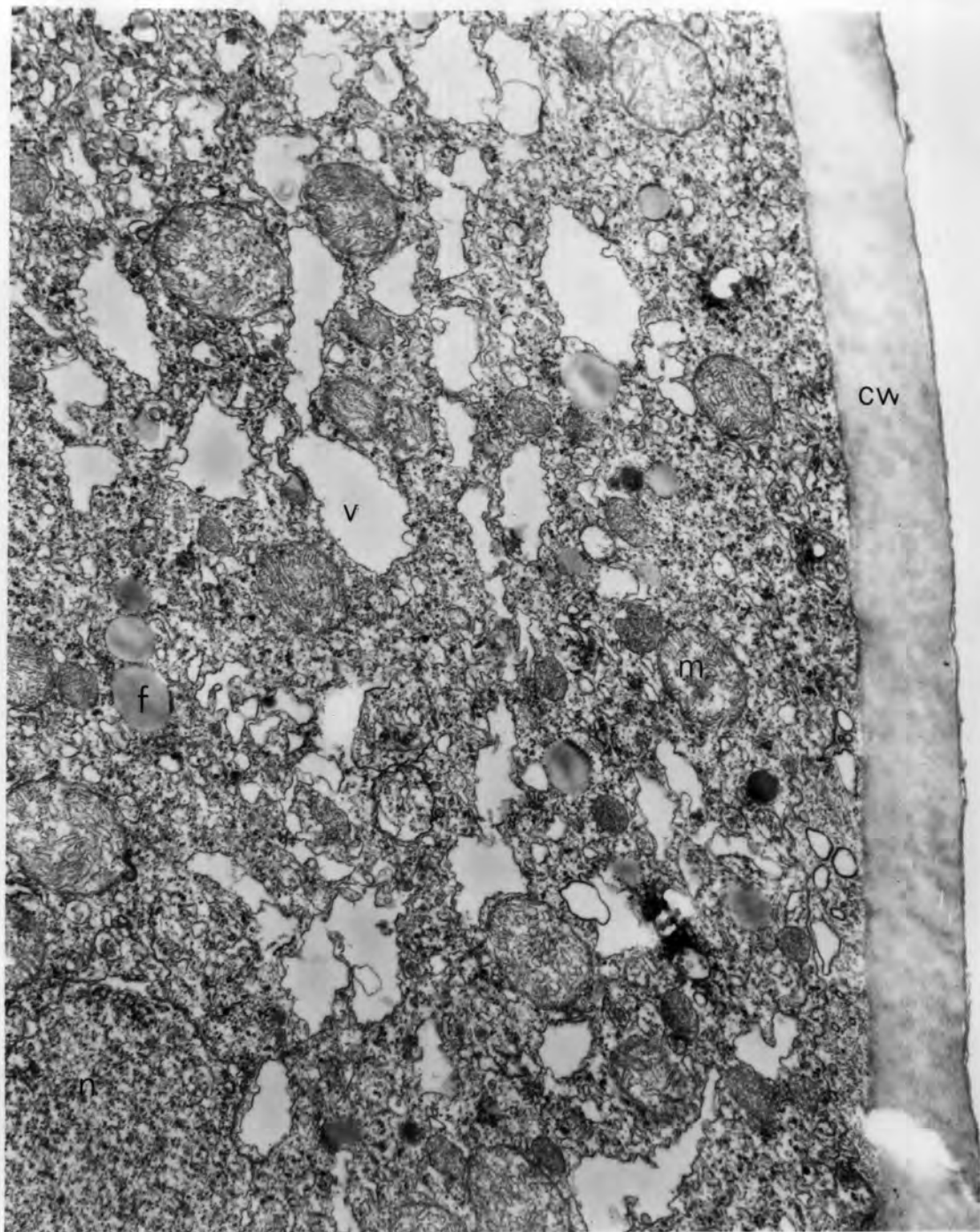

Fig. 7 . Transverse section through growing zone of Stage IV B sporangiophore. Gluteraldehyde fixation - Analdite Embedment . Results of this procedure were usuall poor.

Embedment.

The material which had previously been fixed and dehydrated in a graded series of alcohol was transferred to fresh resin and left at room temperature for 15-16 hours. It was then transferred to fresh resin for an hour before a final transfer to the resin in LKB BEEM plastic capsules. Polymerization was carried out at 40°C for 24 hours followed by 24 hours at 60°C.

Good penetration of the material was achieved and although the blocks were often soft, the material cut well. Electron microscope examination however indicated considerable disruption of the fine structure during polymerization. (fig 8b) The sections were not stable under the electron beam.

(3) Water soluble Durcupon

After fixation the material was washed for 15 minutes in two changes of distilled water. It was then passed through the following series of Durcupon concentrations:

25%	aqueous Durcupon	30 mins
50%	" "	30 "
70%	" "	30 "
90%	" "	30 "

This was followed by two changes of absolute Durcupon for 1 hour each. Finally the material was transferred to fresh Durcupon plus accelerator for 24 hours before polymerization at 40°C.

(4) Glycol Methacrylate (G.M.A.)

After fixation the material was washed in either distilled water or buffer solution. It was then passed through the following concentrations of

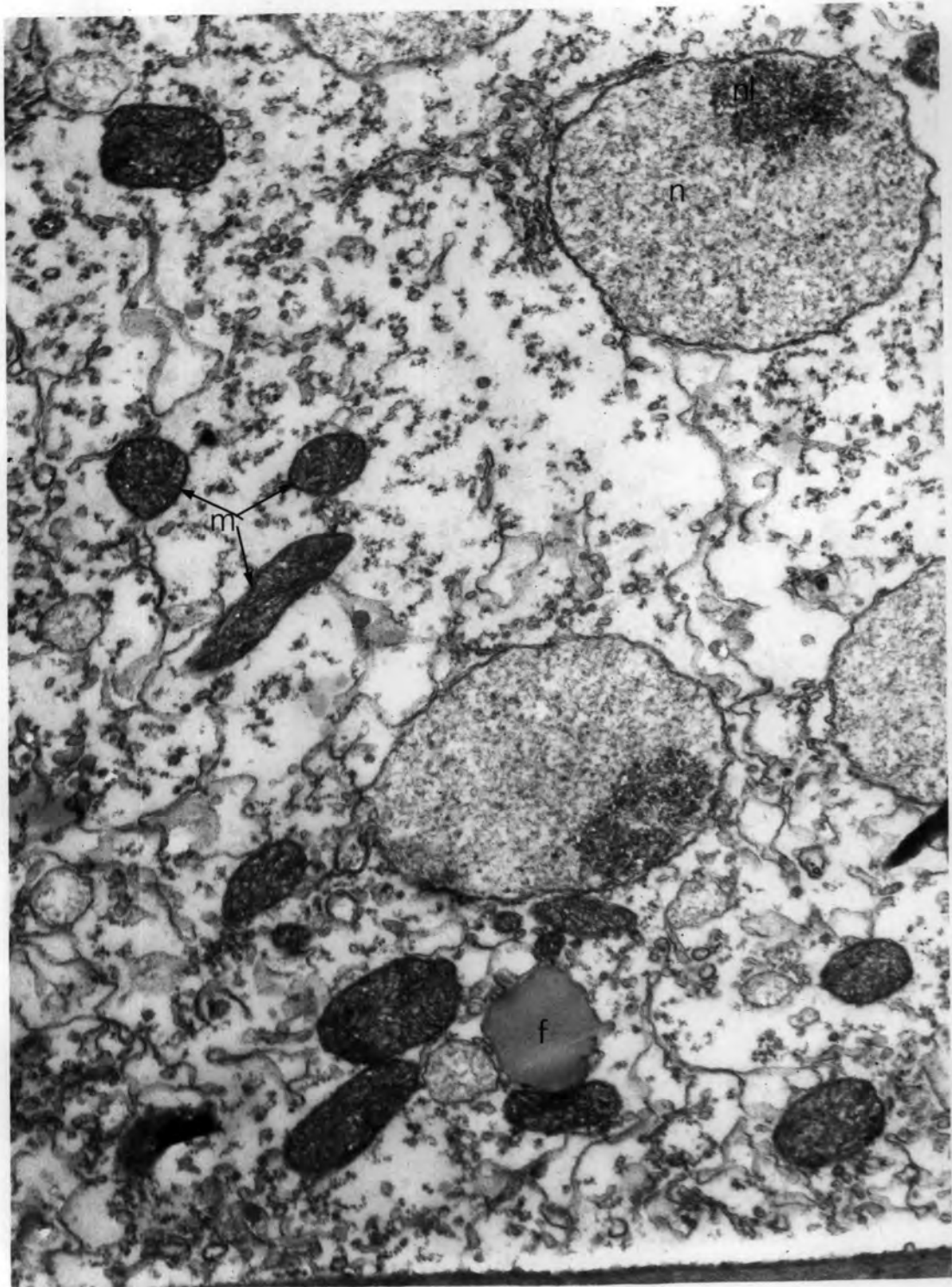

Fig. 8. Transverse section through growing zone of Stage IV B sporangiophore - Gluteraldehyde fixation, Methacrylate Embedment .

glycol methacrylate

30%	aqueous glycol methacrylate	30 mins
50%	" " "	30 mins
70%	" " "	30 mins
80%	" " "	30 mins
90%	" " "	30 mins
	Glycol methacrylate	2 hours

The material was then finally transferred to fresh glycol methacrylate and after 24 hours at room temperature polymerized at 40°C.

Material embedded in these two water soluble resins according to the procedure of Glauert and Glauert "Techniques in Electron Microscopy" (1961) proved impossible to section.

(5) TAAB Embedding Resin.

This proved to be the most satisfactory resin for the embedment of Phycomyces.

Preparation of the Resin.

Equal quantities of TAAB embedding resin and DDSA. v/v were thoroughly mixed together. 0.1 cm³ of the accelerator DMP per 5 cm³ of the resin were added to the embedding resin just before use. It was found that the best cutting blocks were obtained when the mixture had been made up at least one week before being used.

Embedding procedure.

Material that had been fixed and dehydrated in a graded series of alcohol was left overnight in a 50:50 resin/alcohol mixture. It was then transferred to freshly made up resin minus accelerator and left at 60°C for

2-3 days. This facilitated the penetration of the resin. The material was then transferred to fresh resin plus accelerator and left for 2 days at room temperature. It was then transferred to fresh resin plus accelerator in polymerization dishes and polymerized at 40°C for 2 days followed by 2 days at 60°C . This procedure gave good penetration and an even hardness of resin throughout the blocks. The blocks cut well and the sections were extremely stable under the electron beam. There was little evidence of polymerization damage.

IVd Sectioning.

Sections were cut on an L.K.B. ultramicrotome III using glass knives with a cutting angle of 45° . The sections were collected on T.A.A.B. 300 mesh grids coated with 2% formvar and stained with uranyl acetate for 20 minutes followed by a thorough washing in distilled water and a post staining with lead citrate (Reynolds) for 5 minutes. They were then given a final wash in distilled water before examination.

Electron Microscopy.

The sections were examined on an A.E.I 6B Transmission electron microscope at 60 kv magnification 1k to 60k and occasionally at higher magnifications.

Photography.

Photographs were taken on Ilford Special lantern Contrast plates which were developed in Autophen developer. The prints were made on Ilford Photographic Paper.

Section V.

PROTOPLASMIC STREAMING.

Va. Historical Background.

Protoplasmic streaming is a phenomenon that has been recorded for many organisms, both plant and animal. In plant material it was observed for the first time by Corti in 1774 (Kamiya 1959). According to Kamiya's review (1959) many later workers (Frank 1872, Dehnecke 1886, Keller 1890, Kretzshmar 1904) observing the streaming regarded it as an abnormal phenomenon occurring only when the cell was injured or subjected to environmental changes.

Hauptfleisch (1892) distinguished two classes of protoplasmic streaming:- a primary streaming which occurs in cells under normal and natural conditions and a secondary streaming which is established in cells the protoplasm of which has been in a quiescent state as a result of some physical or chemical stimulus. Velten (1872) thought that protoplasmic streaming was a common phenomenon appearing at a certain stage in the life of the protoplasm of the cell. Kamiya's review (1959) (Schorr 1935, Linderheim 1937, Pop 1938) suggests that it was not until the beginning of the 1930's that protoplasmic streaming was generally accepted as a naturally occurring process in intact cells

with an active metabolism.

The numerous modes of protoplasmic streaming and the vast literature of work dealing with this streaming were well summarised by Kamiya in his review entitled 'Protoplasmic Streaming' published in 1959. Streaming in most organisms is observed because of the rotation of granules. If it were not for the presence of these granules of varying kinds and size which serve as markers to indicate the flow it would be extremely difficult to recognise protoplasmic streaming within the cell. However one should not assume that the visible movement of these granules indicates precisely the flow of the groundplasm in which they are suspended, nor that it is only the granules themselves that actively move.

It has been suggested by Nagai & Rebhun (1966) after reviewing the work of Hoffman-Berling, Bettex-Galland & Luscher, Nakajima, Vorobyeva and Poglazov & Schmidt that there is possibly a common macro-molecular entity which may be the universal mechanochemical transducer involved in non muscular motility and that this is probably organised into some macro-molecular complex which is then repeated many times in some three dimensional pattern rather than being randomly dispersed. They suggest that the bundles of 50 $\overset{0}{\text{A}}$ microfilaments may be the direct mechanochemical transducer of streaming in the cytoplasm of Nitella.

Kavanau (1963), Kane (1962) working on mitotic apparatus, Ledbetter & Porter (1963) on meristematic cells and Roth (1964) on various protozoa have suggested that microtubes are the most probable elements involved in primitive mobility.

Wohlfarth-Bottermann (1964) found no microtubes in Physarum but filaments about 70 Å in diameter which he believed to be the basis of motility in this organism. This view has been strengthened by the findings in several protozoa, of similar filaments possibly involved in contraction and the presence in smooth muscle of filaments generally thought to be contractile.

Jahn & Bovee (1969) in their comprehensive review on protoplasmic movement within cells are of the opinion that there is sufficient evidence to indicate a basic biochemomechanical mechanism that powers protoplasmic movements in all kinds of cells, and that this exists within the cells as a sort of actomyosinoid protein. From this pool labile fibrils and gels are formed which interact and move in relation to one another, splitting ATP to produce the energy for the formation and interaction of the fibrils and gels and for their subsequent movement.

In those cells which show streaming along well defined tracks they postulate the formation of discrete actin fibrils or tubules along which such organelles as chloroplasts and mitochondria are carried by the motion of cytoplasmic microstructures

to which they are fixed. It is suggested that the organelles which possess both ATP and small quantities of actomyosin with ATPase activity may have a subsidiary self active role in their movements, especially the more abrupt ones.

Vb. Protoplasmic Streaming in Phycomyces Sporangiohores.

Pop (1938) describes the protoplasmic streaming in the sporangiohores of Phycomyces as occurring in two concentric tubes. A tubular ascent of the protoplasm takes place around a central sap vacuole towards the top of the sporangiohore growth zone where the protoplasm turns back in a tubular stream towards the sporangiohore base, flowing between the ascending stream and the sporangiohore wall. Pop states that he was unable to observe spiral streaming within the sporangiohore, it being nearly always parallel to the long axis of the cell.

Vc. Observations.

Sporangiohores of both the plus and minus strains of Phycomyces blakesleeanus were plucked from the mycelium by means of a pair of fine forceps applied at their bases. The procedure produced no damage to the cell and they could be observed for several hours under the phase contrast microscope.

The plucked sporangiohores were transferred to a drop of water on a microscope slide and covered with

a coverslip supported on two pieces of fine drawn-out glass tubing. Although hundreds of sporangiophores were examined in this way the tubular streaming of the protoplasm described by Pop (1938) was never observed.

In the Stage IV B sporangiophores of Phycomyces blakesleeanus the protoplasmic streaming appears as a well orientated and well organised phenomenon (Table II) when viewed under the phase contrast microscope. In these sporangiophores vigorous and characteristic multistriate streaming was always observed (Figs. 9a, b). At temperatures of about 20°C the velocity of movement, calculated by timing the movement of particles between two fixed points in the calibrated eye piece, was estimated as being 2.2u-3.6u/sec. (Table III). These calculations agree with those cited by Kamiya (1962). It was observed that the smaller particles - mitochondria etc., moved at a greater velocity than the larger ones i.e. nuclei. The various particles within any one microstream of cytoplasm could be seen moving in the same or opposite direction along the longitudinal axis of the sporangiophore. The particles were frequently seen to be deflected from their line of movement on meeting what can only be envisaged as an obstacle to progression. This deflection was usually followed by several similar abortive attempts to proceed before finally returning along the original path. Particles moving in the same direction within a cytoplasmic strand were often observed increasing their speed of movement as they moved along the

Table reflecting Spatial Organization of Protoplasmic Streams within the Sporangioophores

Height in cms.	Width in μ	\bar{x} Distance between protoplasmic streams	Average Distance
1.8 cms	1065 μ	15 μ , 14, 25, 22 μ	19 μ
1.8 cms	480 μ	42, 45, 50, 50 μ	46.75 μ
2.2 cms	300 μ	50, 58, 52, 91 μ	62.75 μ
3.7 cms	233 μ	85 μ , 100, 175 μ	120 μ
6.5 cms	337 μ	59 μ , 193, 209 μ	153.6 μ
7.0 cms	330 μ	88, 150, 170 μ	102.6 μ

* Distance measured at various points along the sporangioophore

TABLE III

Table to show Velocity of Organelles moving in a Protoplasmic Stream of Phycomyces blakesleeianus

Sporangioophore Streams	Time in sec. for Organelles to move across a distance of 40 μ	Average Time
Minus strain 1a	16, 16, 15, 17, 10, 16, 18, 21	16.38
1b	13, 10.5, 11, 13, 11.5, 15, 13	12.42
2a	20.5, 20, 17.5, 18, 17, 15.5, 19, 20	18.44
2b	12, 12.5, 11, 11, 10.5, 11, 13, 15	12.0
3a	12.5, 12, 12, 13, 14.5, 9.5, 10, 10.5	11.62
Plus strain 1a	11, 10, 16, 12, 11, 11.5, 10, 10	11.44
2a	10, 9.5, 10, 5, 11, 13, 5, 10	10.75
3a	12.5, 12, 13.5, 13, 12, 14, 12	12.71
		Chanel not particularly obvious
3b	11, 13, 14, 15, 13, 20, 14, 16	14.5
4a	10, 11, 12, 10, 10.5, 11, 13, 12	11.18

a- movement from base to apex of sporangioophore
 b- movement from apex to base of sporangioophore



Fig 9a Two sporangiophores showing protoplasmic streams X.100

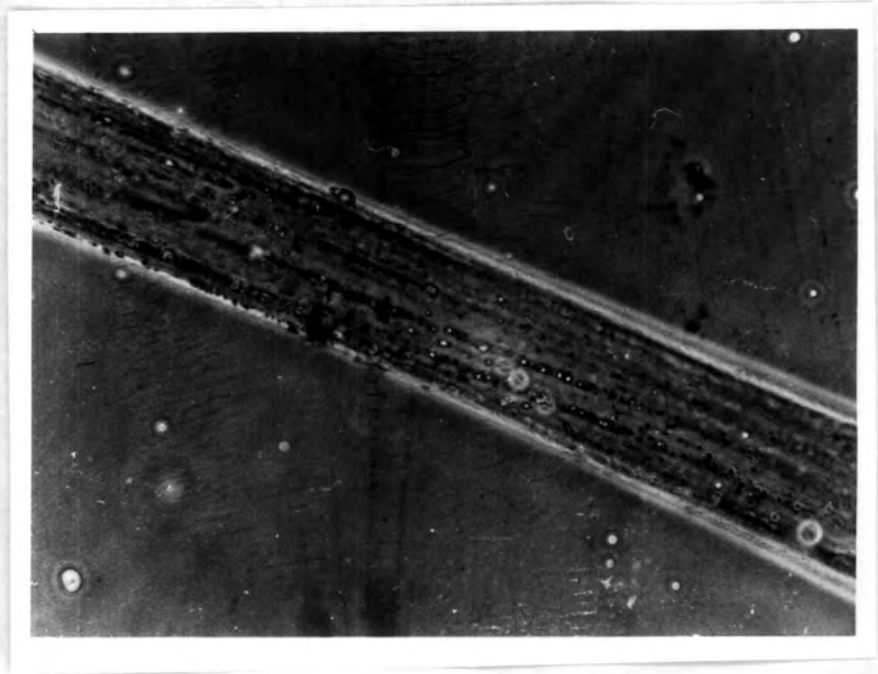

Fig 9b The Protoplasmic streams are almost parallel to the long axis of the sporangiophore X.100

strand so that they frequently passed each other as they progressed. In order to pass round a particle moving at a lower velocity a particle moving at a higher velocity often first collided with the obstacle particle, retraced its path over a short distance and then moved forward again on a slightly deviated path, moving back to its apparent original course after having negotiated the obstacle. The movement resembled in many ways the negotiating of an obstacle by many protozoan organisms.

When observed under a Leitz phase contrast microscope with an oil immersion lens the cytoplasmic strands were at times seen to exhibit a pulsating movement. (Figs. 9c, d).

All these features strongly suggested the existence within the cytoplasm of a structure, to which the particles were in some way elastically linked, which determined the general direction of flow. The variations in velocity however suggested that the particles move with their own localised impulse, although one cannot ignore a possible role of the ground cytoplasm in assisting movement in one direction.

These findings with the light microscope led me to believe that there might possibly be a system of microtubules or fibrils within the cytoplasm along which the organelles moved as a consequence of lasting or transient attachment. Movement of a structural system has been envisaged in terms of jet propulsion

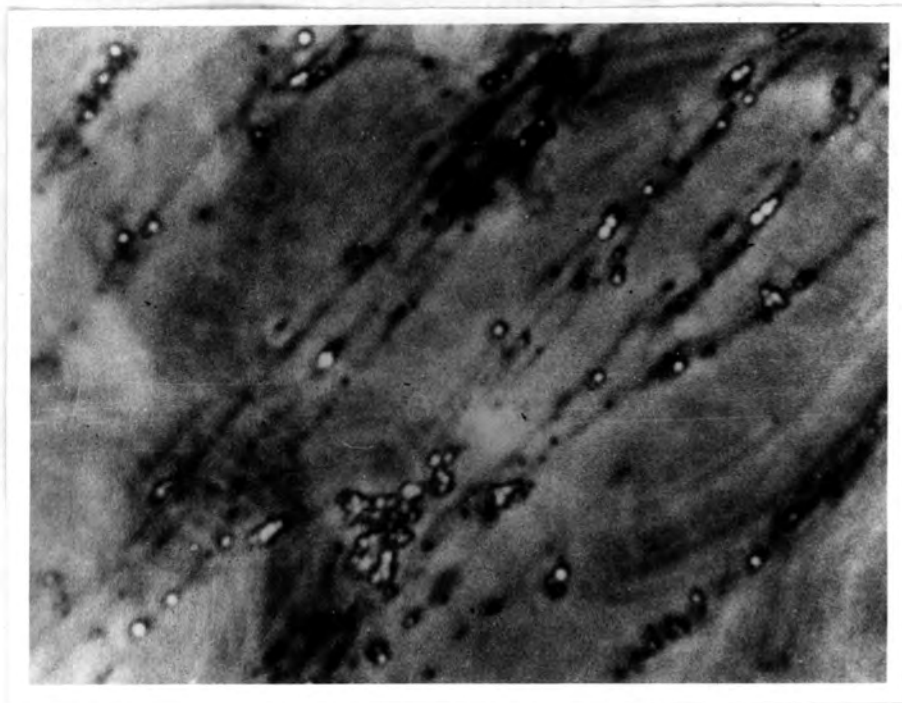

Fig 9c A 'vesicle' can be observed in two of the Protoplasmic streams. X 900

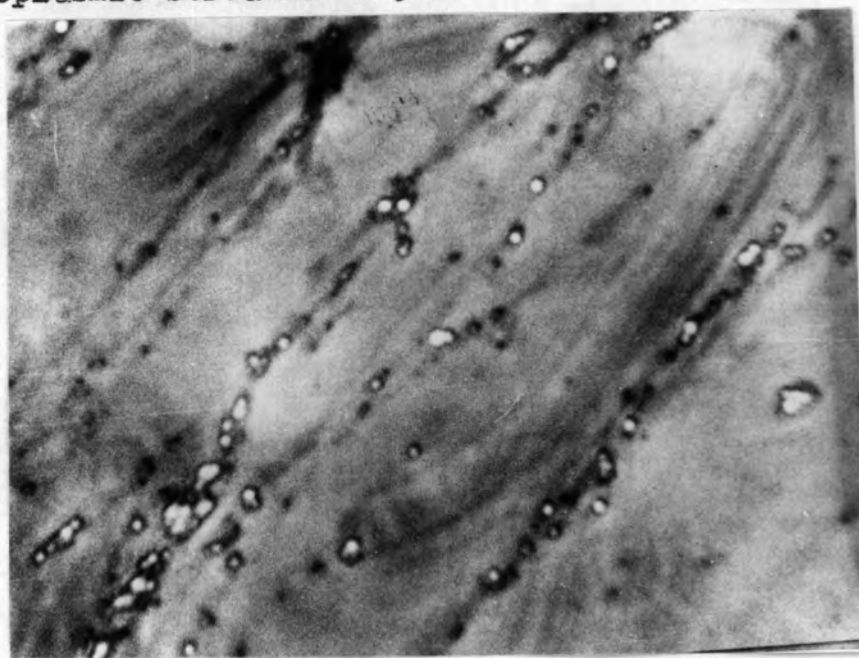

Fig 9d less than one second later the vesicles are no longer visible - such vesicles appeared to pass in wave like motion along the streams X.900



of fluid from microtubules (Kavanau 1963) and as previously stated as cycles of contraction and relaxation of fibrils.

Vd. Organelle Distribution in Relation to Protoplasmic Streaming.

An attempt was made using various staining techniques for the light microscope, to determine the nature of the organelles moving along the fine strands of protoplasm. Since most staining techniques involve pretreatment with fixatives that caused considerable distortion of the cytoplasmic contents of Phycomyces they did not always provide the desired information.

Materials and Method.

1. Nitroblue tetrazolium - Mitochondria

Living sporangiophores were placed in equal volumes of nitroblue tetrazolium (1 mg 1 mol.) and 0.05 M sodium succinate buffered to pH 7.1 with 0.05 M phosphate buffer. The sporangiophores were then kept at a temperature of 35°C for 20 mins. This was followed by thorough washing in distilled water and mounting in Zeiss water mountant W 15 n_D 1.515. The sporangiophores were examined immediately.

2. Janus Green - Supravital stain for Mitochondria

Living hyphae were placed in a solution of Janus Green 1/1,000 in distilled water on a microscope slide. They were then covered and examined immediately. This is a supravital stain for mitochondria and their

position in the living hyphae could thus be readily determined.

3. Feulgen's stain (Jones 1947) - Nuclei

Sporangiophores were fixed for 2 hours in Carnoy's B fixative (6 parts ethyl alcohol, 1 part glacial acetic acid and 3 parts chloroform). They were then rinsed for 20-30 mins in distilled water. The fixed material was then hydrolysed in N. hydrochloric acid for 5 mins at room temperature, followed by 5-7 mins at 70°C and a further 5 mins at room temperature. The sporangiophores were then removed from the acid, washed thoroughly, placed in distilled water for 5 mins and finally stained in Feulgen's reagent for 5-10 hours at room temperature. After staining the material was bleached in water containing sulphur dioxide for 30 secs to 5 mins. This was followed by rinsing in distilled water, dehydration, clearing and mounting in Euparal. Some sporangiophores were mounted immediately after rinsing in Zeiss water mountant.

Dehydration was carried out by placing the material for 5 mins in each of 20%, 30%, 50% and 70% alcohol and 10 mins in each of 85%, 95% and absolute alcohol. The sporangiophores were cleared by leaving them for 5 mins in 75/25%, 50/50% and 25/75% alcohol-xylene mixture and 100% xylene.

A few sporangiophores were counter stained with 10% Orange G in 70% alcohol. The counter staining was carried out at the 70% alcohol stage of dehydration

when they were transferred to the stain for 5 mins. Excess stain was removed in 70% alcohol before the material was dehydrated, cleared and mounted as above.

4. Sudan III - Fats

Living hyphae were placed on a microscope slide and flooded with Sudan III (0.1 gms Sudan III in 50 mls of 95% ethyl alcohol and 50 mls of glycerol). After 5 mins the Sudan III was drained away and the sporangiophores were mounted in equal parts of 95% ethyl alcohol and glycerol, covered and examined immediately.

5. Korson's Stain (Korson 1951)

Sporangiophores were fixed for 30 mins in a modified Carnoy's B fixative (2 parts ethyl alcohol, 3 parts chloroform and 1 part glacial acetic acid). They were then washed for 30 mins each in two changes of 85% alcohol and then brought down to water through 75%, 50% and 25% alcohol. The fixed material was then stained as follows:-

It was first placed in Korson's solution A (4% Orange G in distilled water) for 3-5 mins, washed in distilled water containing a drop of Korson's solution A. The material was then transferred to Korson's solution B (0.15% methyl green in distilled water) for 15 mins, drained and then transferred to Korson's solution C (one part 0.15% methyl green in distilled water and one part 0.1% toluidine blue in distilled water) for 5 mins. After staining the

material was taken through a graded series of n butyl alcohol and finally left overnight in fresh n butyl alcohol to complete destaining. This long period of destaining is essential for delicate and precise staining. Following destaining the material was then washed in xylol and mounted in Zeiss mountant or Euparal.

Results.

1. Nitroblue tetrazolium.

Aggregates of mitochondria appeared in the following locations:- (Fig.10) a-f)

- (a) From 0-1 mm below the sporangium of the Stage I and IV B sporangiophores.
- (b) From 0- $\frac{1}{2}$ or 1 mm up from the base of the Stage I and IV B sporangiophores.
- (c) In the storage vesicles of the mycelium.
- (d) At the points of branching of the mycelium.
- (e) In the columella.

2. Janus Green - Supravital stain: (Figs. g-h)

The results of this staining procedure again showed the presence of large numbers of mitochondria:-

- (a) below the sporangium of the Stage IV B sporangiophore.
- (b) at the base of the sporangiophore
- (c) in the storage vesicles of the mycelium and, in addition to the above locations, in the fine protoplasmic streams running along the long axis of each sporangiophore.

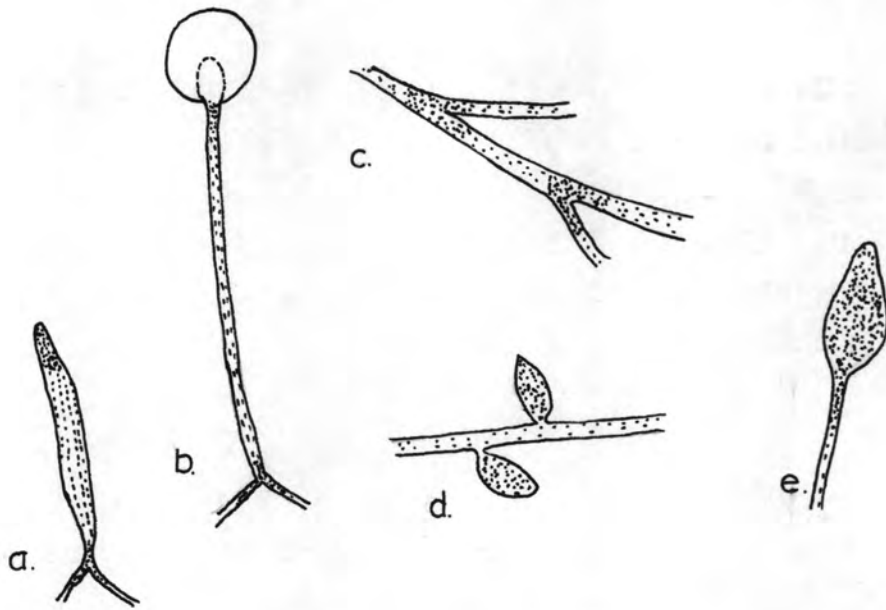

Fig.10a Results of staining with nitroblue - tetrazolium
 a) stage I sporangiophore, b) stage IVB sporangiophore
 c) branching of mycelium, d) reserve vesicles, e) columella
 after dehiscence of sporangium



Fig.10b Growth zone of sporangiophore stained with
 nitroblue - tetrazolium X 100

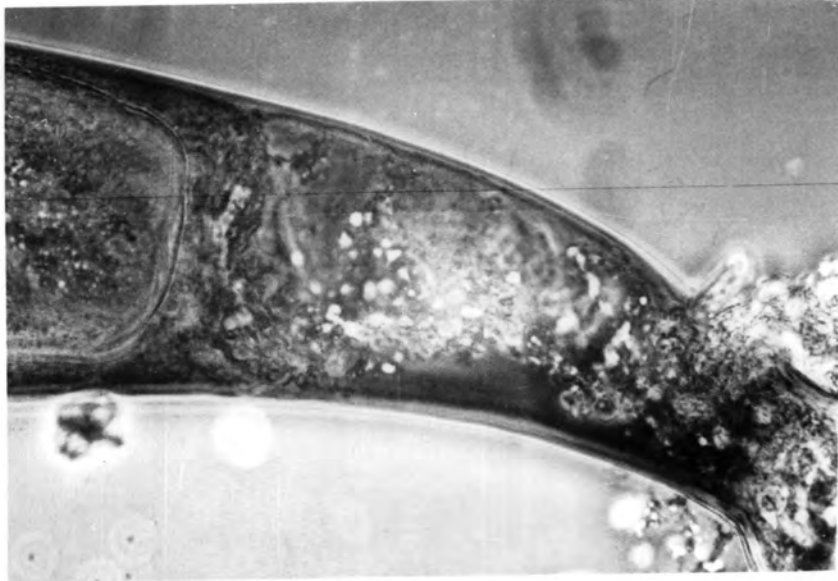

Fig 10c Sporangiophore base containing numerous mitochondria - nitroblue-tetrazolium stain X.200

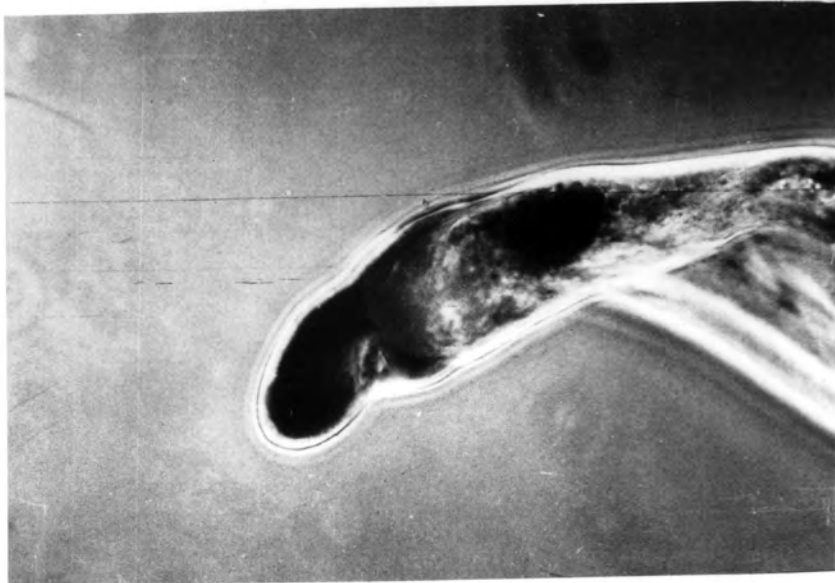

Fig 10d Apex stage I sporangiophore showing dense aggregation of mitochondria - nitroblue-tetrazolium stain X.100





Fig 10e Columella and growth zone of Sporangiophore
-nitroblue-tetrazolium stain X.100

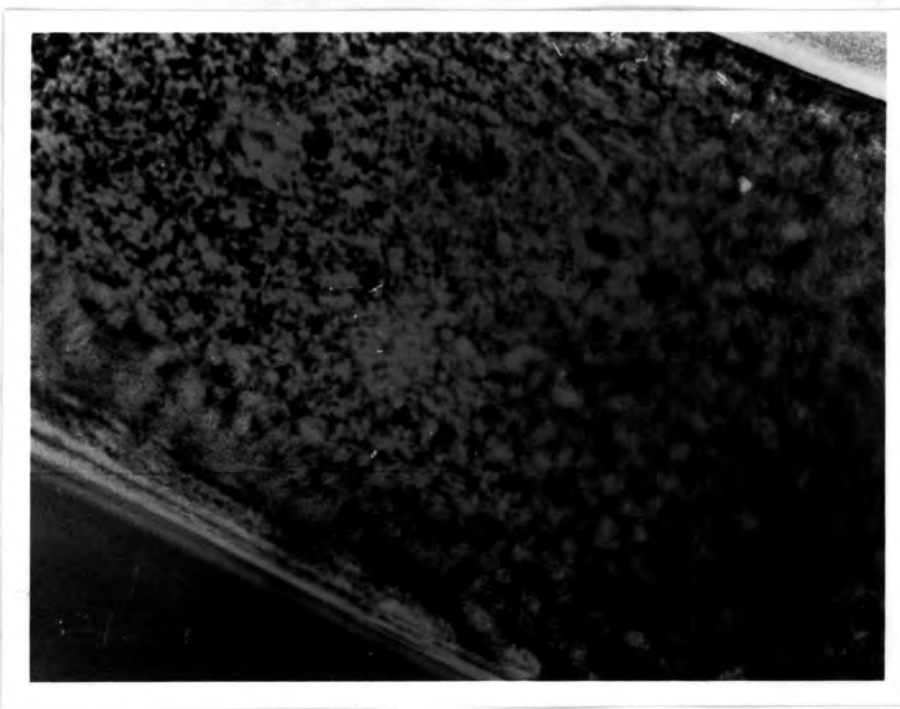

Fig 10f Part of Mature sporangiophore -nitroblue
-tetrazolium stain. Note absence of protoplasmic
streams. X.200



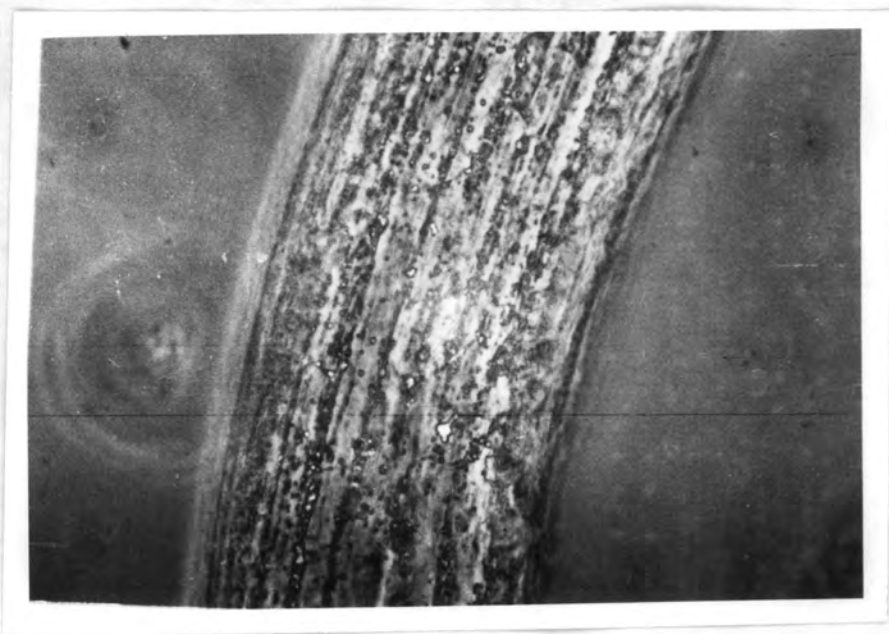

Fig 10g Part of sporangiophore showing protoplasmic streams - Supravital Janus Green stain X.200

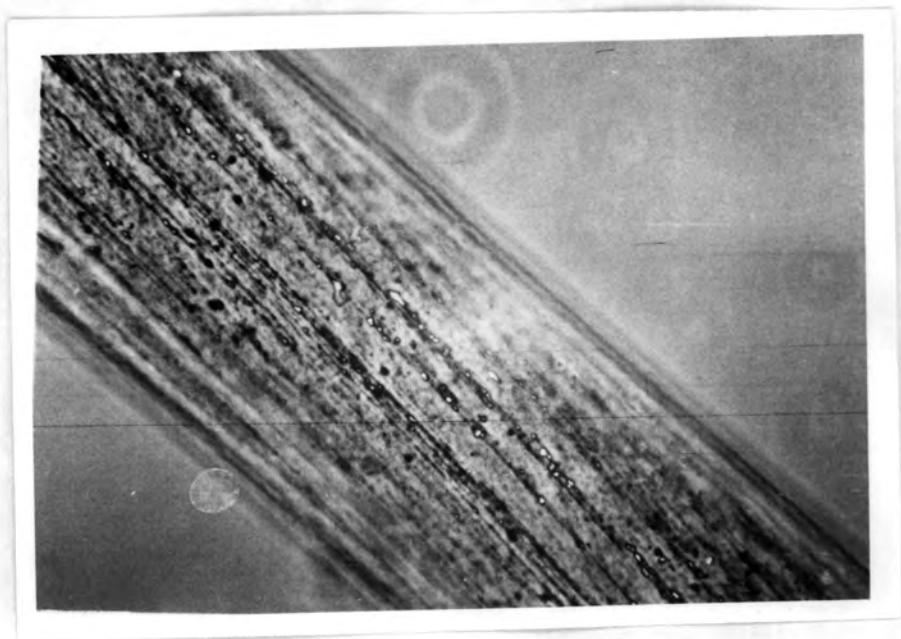

Fig 10h As Fig 10g - Note the dark staining indicating the presence of mitochondria in the protoplasmic streams. X.200



3. Feulgen's Stain.

Nuclei, located by means of the D.N.A. staining with Feulgen's stain, were present:-

(a) In large numbers in the Stage IV B sporangia.

Squashed sporangia showed these nuclei to be located in the spores which had stained deeply.

(b) In the sporangiophore where there was a fairly even distribution of nuclei along the whole length. Although the fixation procedure used prior to staining brought about some distortion of the linear arrangement of organelles and protoplasmic strands it was evident that the nuclei had a linear orientation together with the mitochondria along the length of the sporangiophore.

4. Sudan III.

Fats were apparent along the whole length of the sporangiophore. They appeared as droplets of varying size. An intense orange stain appeared in the Stage IV B sporangium and a deep yellow stain in the columella. In the latter there appeared a well defined peripheral region without stain. There was no evidence of a linear arrangement of the fat droplets.

5. Korson's Stain .

(a) In the terminal 1 mm of the sporangiophore there was an intense green staining indicating the presence of D.N.A. in large quantities.

(b) The sporangiophore itself was stained blue

indicating the presence of ribosomal R.N.A. , but scattered throughout this were areas of green staining indicating the presence of D.N.A. alongside the ribosomes.

(c) Considerable green staining also appeared in the sporangium.

(d) The peripheral region of the terminal 2 mm of the sporangiophore and also the region of the mycelium from which the sporangiophore originates stained a deep violet.

(e) The columella showed a blue staining together with considerable deep violet and a green staining at the base indicating the location of nuclei.

It was however impossible to detect any precise arrangement of organelles within the sporangiophore.

Ve. Electron Microscope Results.

In transverse and longitudinal sections of regions of the Stage IV B sporangiophore between 1 cm and 4 cm below the sporangium the cytoplasm forms a lining to the cell wall and surrounds an extensive vacuole. As the distance from the sporangium base increases the cytoplasmic layer becomes progressively thinner. At a distance of 4 cms or more as seen in Transverse section (Fig 11) the cytoplasmic layer is extremely variable in depth consisting of deep regions in which are embedded organelles such as nuclei and mitochondria separated by thin regions often devoid of organelles. This arrangements of the cytoplasm probably explains the appearance of the longitudinal cytoplasmic strands apparent in entire sporangiophores when viewed under

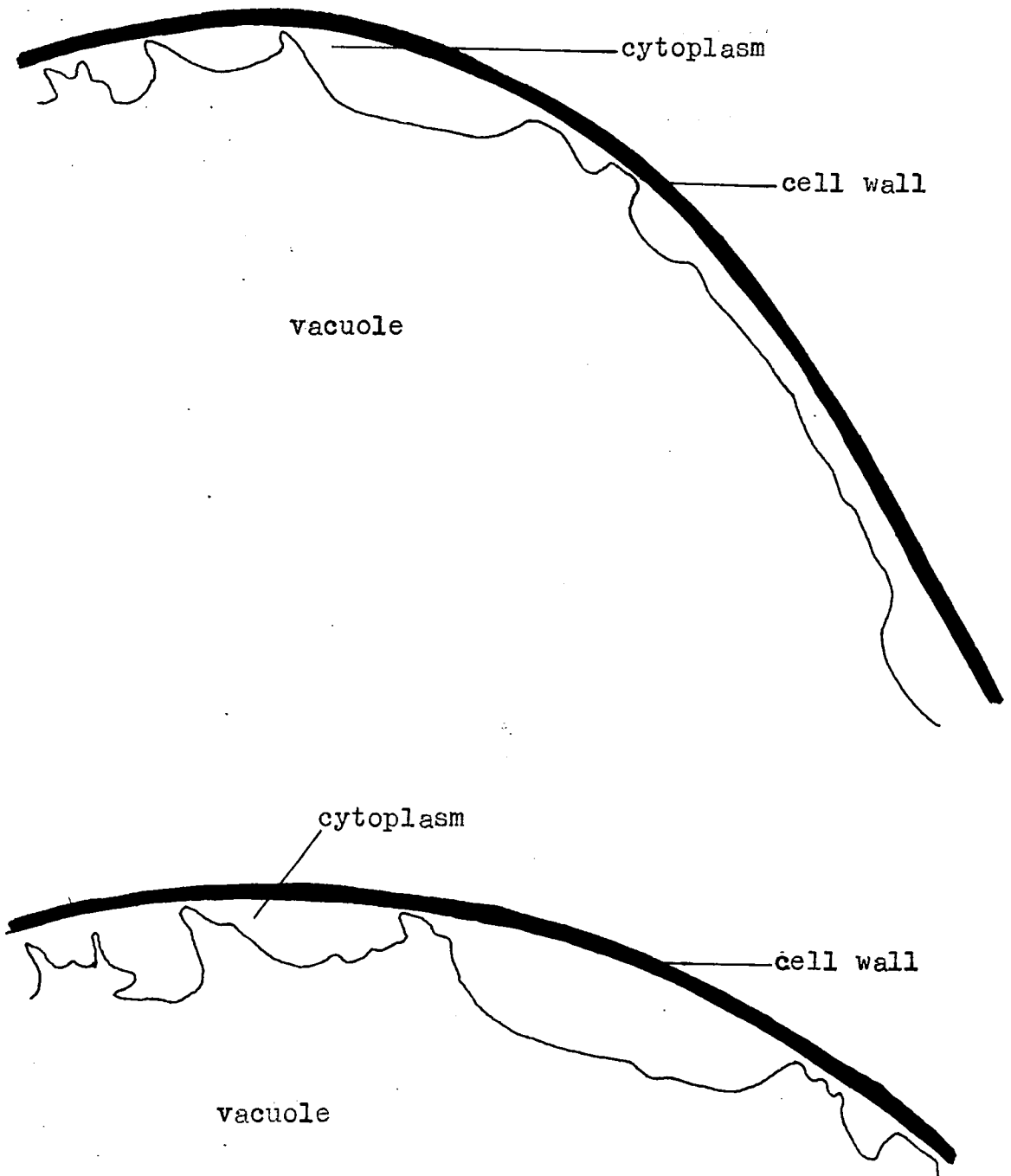

Fig.11 Transverse section of parts of stage IVB sporangio-phores of Phycomyces approximately 4 cm below the sporangium to show the variation in depth of cytoplasm - tracings from an electron microscope plate.

the light microscope.

In preliminary experiments I was unable to find any conclusive evidence of either microtubules or fibrils within the cytoplasm. Although several methods of fixation were used (see Table I, section IV a) nothing was observed which gave any evidence at all for the presence of microtubules. With the Gluteraldehyde-Osmium tetroxide fixative (Franke et al 1969) however many, and in some instances extremely long, microfilaments were observed (Figs. 12 and 13). In some instances mitochondria appeared to be attached to these microfilaments (Fig. 14). These microfilaments were 160 \AA in diameter and were only observed in longitudinal sections suggesting an orientation parallel, or approximately so, to the long axis of the sporangiophore. Microfilaments of similar dimensions were occasionally observed in material prepared by using gluteraldehyde fixative with post osmication (Fig. 15). They were not however so common or so long in this material.

The microfilaments observed in Phycomyces are very similar in diameter to those occurring in Physarum (Crawley 1966). Both are considerably larger in diameter than the microfilaments occurring in most other organisms. No structures corresponding to the 210 \AA microtubules described by Sabnis and Jacobs (1967) in Caulerpa were observed.

From the observations it seems reasonable to suppose that the orientation of the microfilaments

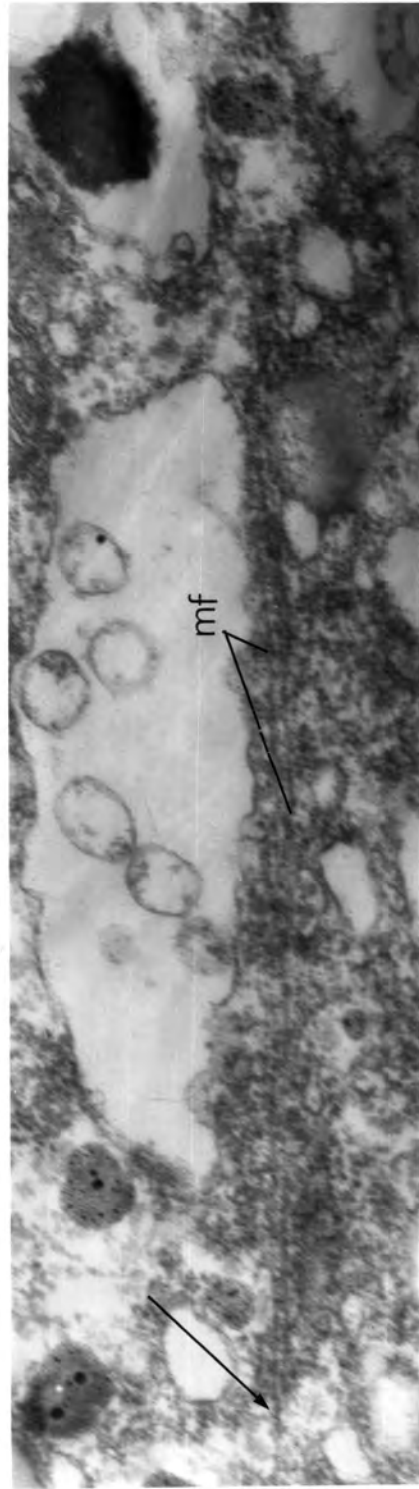

Fig 12

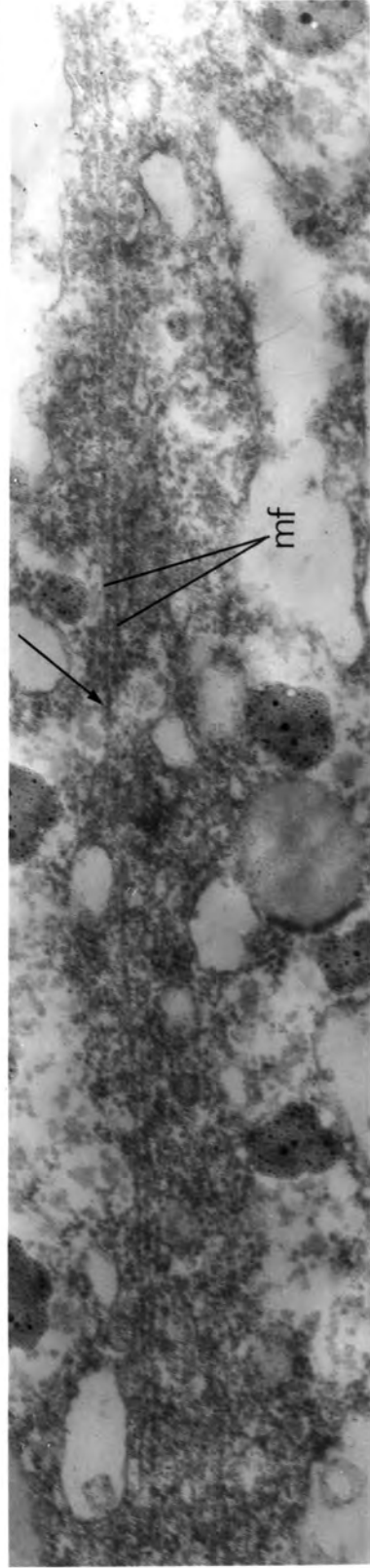

Fig 13.

Fig.12 and Fig.13. Long microfilaments running approximately parallel to the long axis of the sporangiophore. These filaments were over 8.5 μ in length. Arrows indicate point of overlap of two micrographs. Simultaneous gluteraldehyde - osmium tetroxide fixation. X 30,000

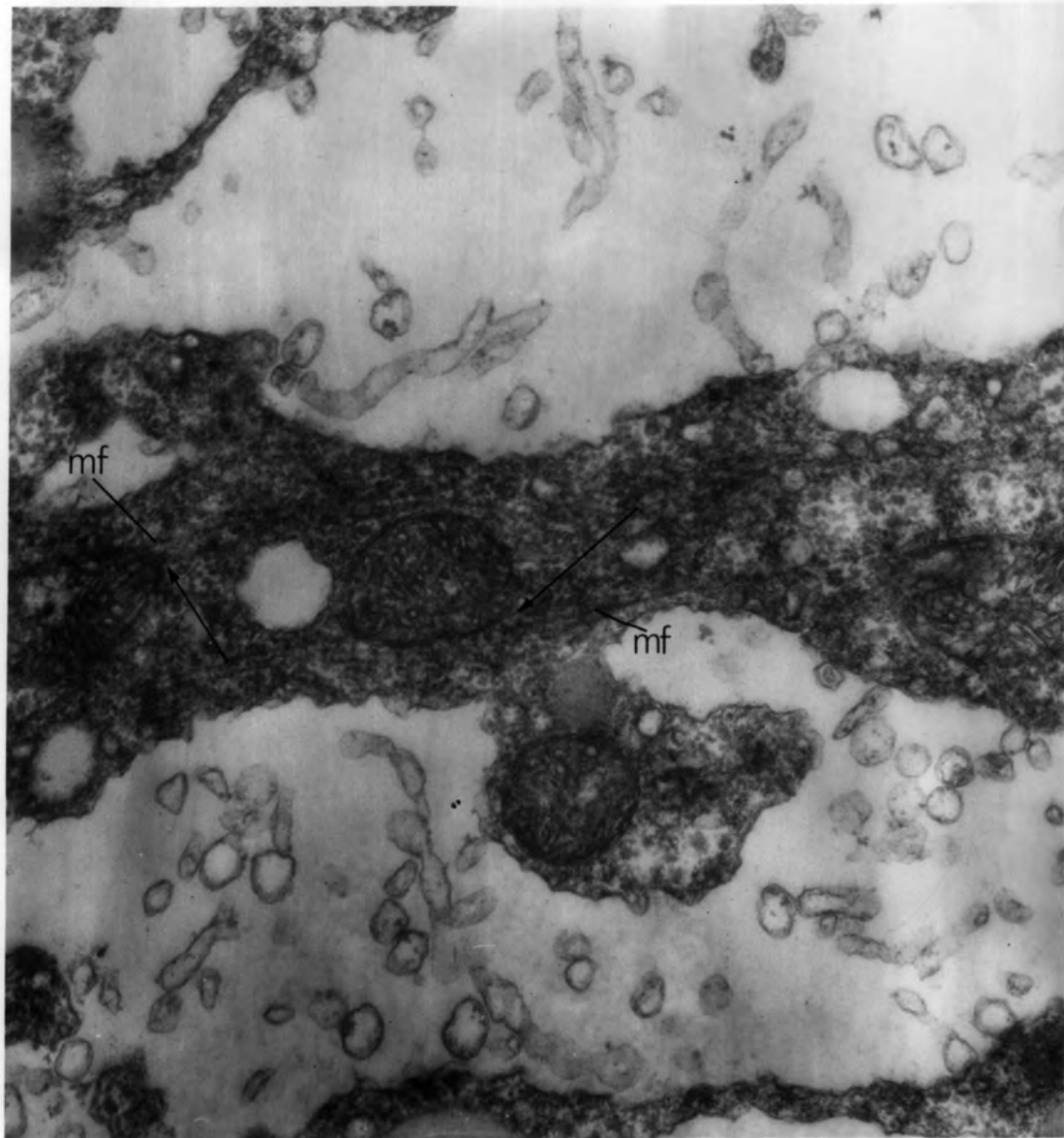

Fig. 14. Microfilaments with closely associated mitochondria. Arrow indicates an apparent link between a filament and a mitochondrion. Simultaneous Gluteraldehyde - Osmium tetroxide fixation. X 30,000

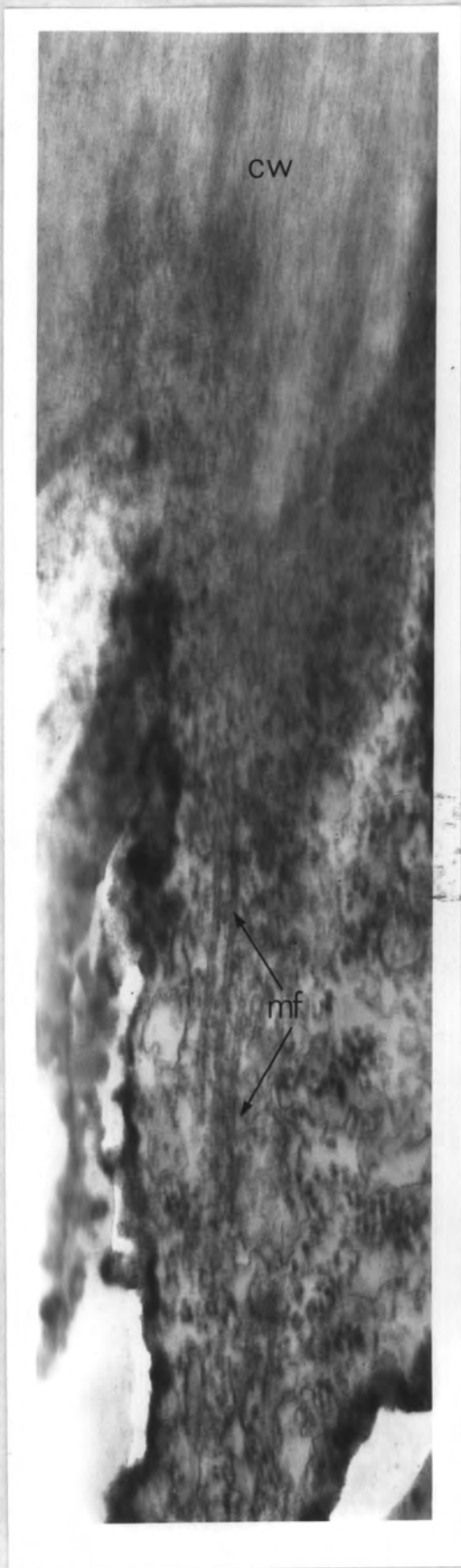

Fig 16.

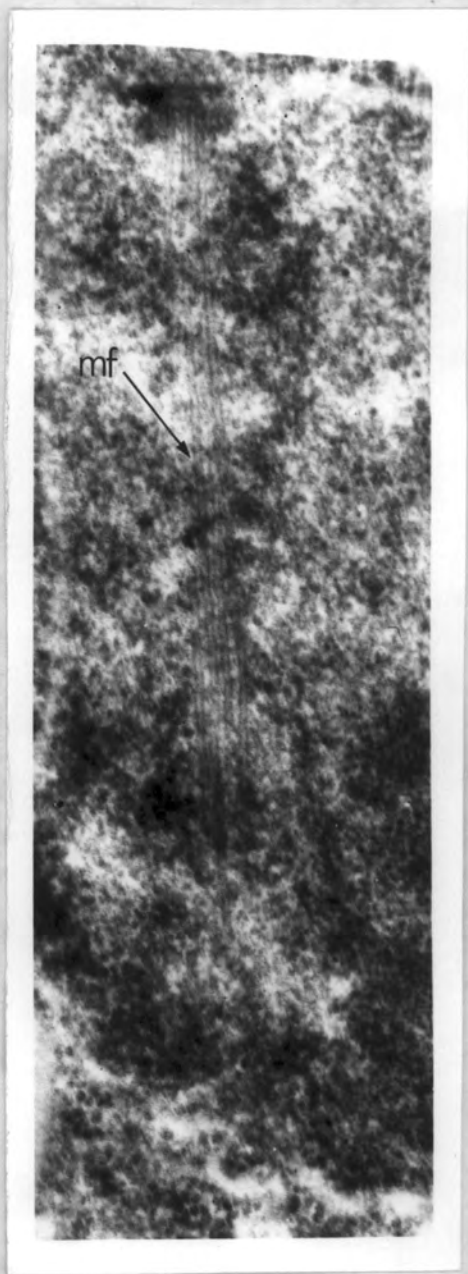

Fig 15.

Fig 15 Microfilament passing across
a nucleus - the double lines
suggest microtubules -
Gluteraldehyde fixation X 63,750

Fig 16 Microfilaments passing from
the cytoplasm into the cell wall
Their orientation is very close
to that of the chitin fibrils

X 60,000



parallel to the long axis of the sporangiophore determines the orientation of protoplasmic streaming. It is possible to envisage a system similar to that suggested by Jahn and Bovee (1969) existing within the sporangiophores of Phycomyces. The mitochondria, which are generally accepted as possessing ATP and ATPase activity, could provide some of the motive force required for their movement and be linked to the cytoplasmic microfilaments by temporary bonds. Such a system would explain why it is possible for moving organelles within a strand of cytoplasm to be able to pass each other and then to continue their forward movement on the same path but moving at different velocities.

This does not however explain the mechanism which determines when the organelles will move from base to apex or from apex to base of the sporangiophore. From the observed rates of movements of the organelles in the two opposing directions (see Table III) it seems unlikely, as was once suggested, (see Kamiya 1959) that the primary force develops from a turgor pressure at the base of the sporangiophore.

Vf. Protoplasmic Streaming in Relation to Secondary Wall Development.

It is believed by some investigators that the spiral flow of the cytoplasm might play some part in the deposition of the secondary chitin molecules into the primary wall structure laid down in the growing region of the sporangiophore. In oblique sections of

the Stage IV B sporangiophore taken from more than 2 cm below the sporangium the internal boundary of the wall was seen to be extremely irregular in form possessing numerous sharp inward projections. Passing from the cytoplasm into these projections of wall materials microfilaments could often be observed (Fig. 16). From the nature of the wall as seen in transverse, longitudinal and oblique sections a three dimensional model of the structure of the wall can be built up. (Fig. 17). It will possess numerous raised areas orientated with their long axes obliquely, at an angle in the region of 45° to the long axis of the sporangiophore. The position of the microfilaments seen passing into these raised areas indicates that they enter at an angle to the long axis of the sporangiophore closely approximating that of the secondary wall fibres, thus suggesting an orientation in a loose spiral within the cytoplasm. Such an orientation would also account for the appearance of the fibrils in the wall as seen in longitudinal sections.

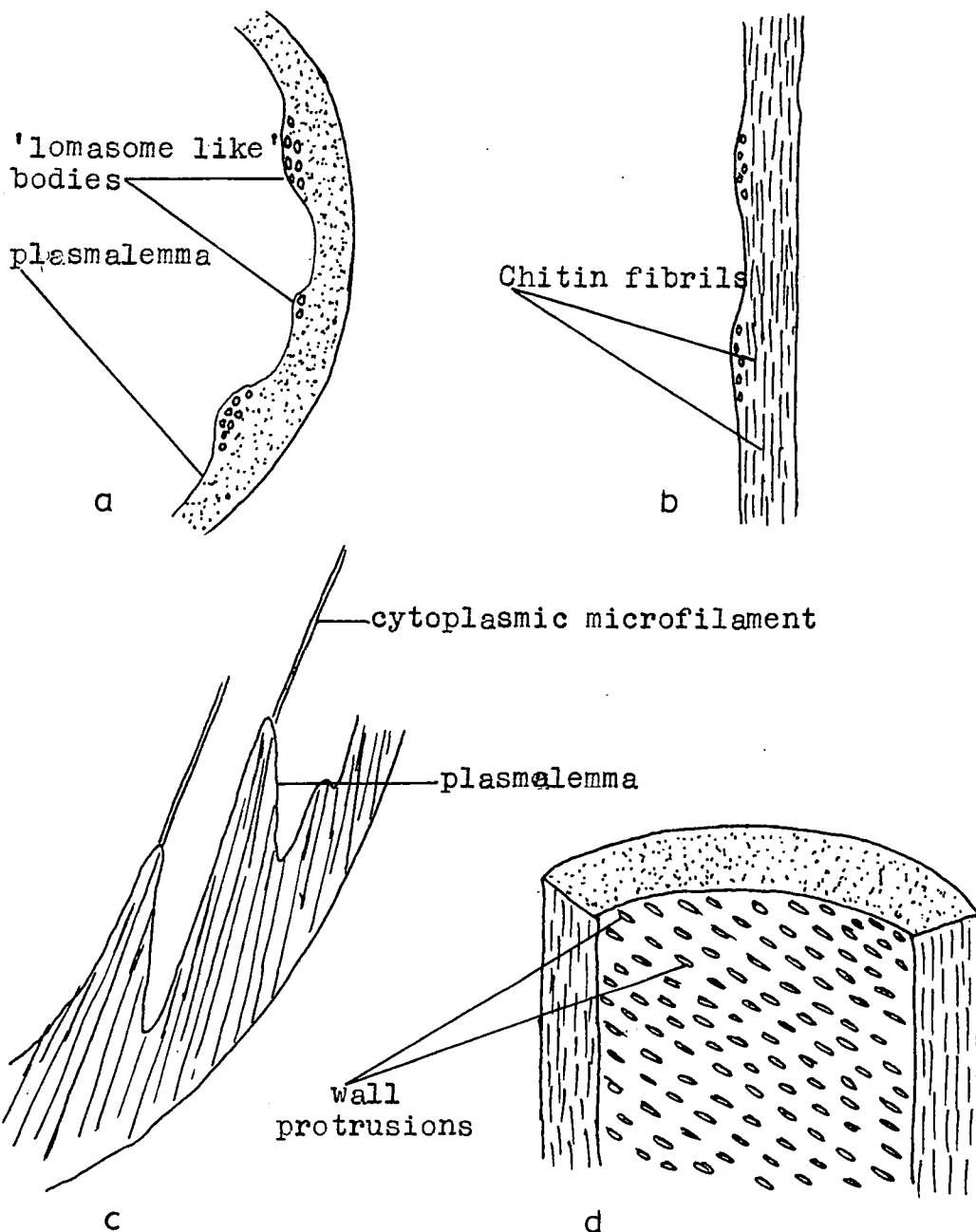

Fig 17 Diagrams to illustrate the appearance of the chitin fibrils in the wall of the growth zone *Phycomyces* sporangiophore a) transverse section - no fibrillar structure apparent, b) longitudinal section - short fibrils present c) oblique longitudinal section - long fibrils present - microfilament pass into wall from cytoplasm d) three dimensional plan of sporangiophore wall

Section VI

Geoperception in Phycomyces Sporangiohores

VIa Historical

When a sporangiophore of Phycomyces blakesleeanus is placed with its long axis in a horizontal plane, the growing region curves upwards until its direction of growth is vertical. It thus exhibits a negative geotropic response. The response begins after a variable latency of 30-180 mins in mature stage IV B sporangiophores. The bending rates for wild types may be as high as $0.3^{\circ}/\text{min}$ initially when the angle between gravity and the growth zone is 90° , but drops to about $0.17^{\circ}/\text{min}$ when the angle is 45° and about $0.08^{\circ}/\text{min}$ when the angle is 20° . Thus, starting from the horizontal, about 12 hours is required for the sporangiophore to reach the vertical (Dennison 1961).

Dennison also found that there is considerable variability in the latent period and in the initial bending speed. He suggested that this might reflect a variation in the growth rate or in the sensitivity to gravity, due to such factors as sporangiophore maturity, culture age, and possibly, humidity. However, one cannot overlook the possibility that two or more of these factors may be involved.

Further results of Dennison showed that when vertical sporangiophores are centrifuged about a

vertical axis at a Resultant Gravitational Force greater than 1.47 g the geotropic response is more rapid than with natural gravity, and continues until the direction of growth is parallel to the resultant of the gravitational and centrifugal vectors. Dennison found that at any specific angle the geotropic bending speed increased with increased centrifugal force in the range of 1-4.3g.

In addition to the response to steady gravitational force a transient response, occurring only after a change in centrifugal stimulus, also occurs in Phycomyces sporangiophores. This response has two phases. The first, occurring immediately upon changing the relative centrifugal force, is in the direction of the change of force and appears to be an elastic flexing under the changing imposed force. The second or active phase begins within two minutes after the beginning of the change in relative centrifugal force and lasts for about 5 mins. It represents an active growth response, and occurs in a sense opposite to the effect of the change in the flexing force. This transient response is superimposed on the relatively slow geotropic response elicited by steady gravitational stimulus.

Dennison was able to show that the transient response is due to the change in the external forces acting on the sporangiophore, and the resulting deformation of the growth zone, whereas the long term

response is not due to the deformation of the growing zone under external forces. When the sporangiophores were totally immersed in FC-43 (a fluorine-substituted hydrocarbon fluid of high relative density- 1.87) during the centrifugation, the transient geotropic response was reversed, but the long term geotropic response was substantially unaffected, despite the fact that the greater density of FC-43 would result in the externally acting forces being the reverse of those on sporangiophores centrifuged in air. He concluded that the long term response to a steady gravitational stimulus must be due to the actions of the stimulus on an internal sensory apparatus.

Investigation for Sensory Apparatus.

Sporangiophores of Phycomyces blakesleeanus grown on 2% malt agar under normal daily light variations were plucked from the mycelium when they were approximately 2 cm tall and prepared for electron microscopy. Transverse sections at 0.5 mm, 1 mm, 1.5 mm and 2 mm below the sporangium were examined under the electron microscope.

(1) Ultrastructure of the growth zone of the sporangiophore.

The ultrastructural features of the cytoplasm are the same at all levels in the growth zone. The sporangiophore is bounded by a cuticle which sometimes during the preparation of the material may become separated from the chitinous (Roelofsen 1951) cell wall which in the growth zone is approximately 2 μ m thick. From immediately below the sporangial swelling the columella wall extends downwards as an inner

lining within the sporangiophore wall for a distance of about 0.05 mm (Fig.18). In the terminal 0.5 mm of the growth zone small vacuoles coalesce (Figs.19 and 20) to form the large central vacuole which extends down to the sporangiophore base. Within this vacuole, and occasionally within the cytoplasm, crystals of various sizes and forms are found; they have been identified (Wolken 1969) as probably being a riboflavin protein complex (Fig.21).

These crystals bear a close resemblance to the intra mitochondrial crystals found in the epitheliomuscular cells of sexual and regenerating Hydra (Davis 1967) and to some of the macrocrystals found in the seeds of Fraxinus excelsior and Fraxinus americana (Villiers 1968). At high magnification crystal lattices could often be resolved. These appeared either as a regular system of parallel electron dense lines 130 Å apart with a repeating pattern of electron dense short side branches also of approximately 130 Å apart. In other sections, presumably cut in other planes, the lattice appeared more nearly as two sets of parallel lines intersecting at angles of 105° and 75°. Villiers suggests that the intranuclear crystals of Fraxinus represent storage protein for use in germination, and Davis also indicates that the intra mitochondrial crystals of Hydra may also be a storage product, although similar crystals were found by Oschman in Hydra viridis which had been starved for five days.

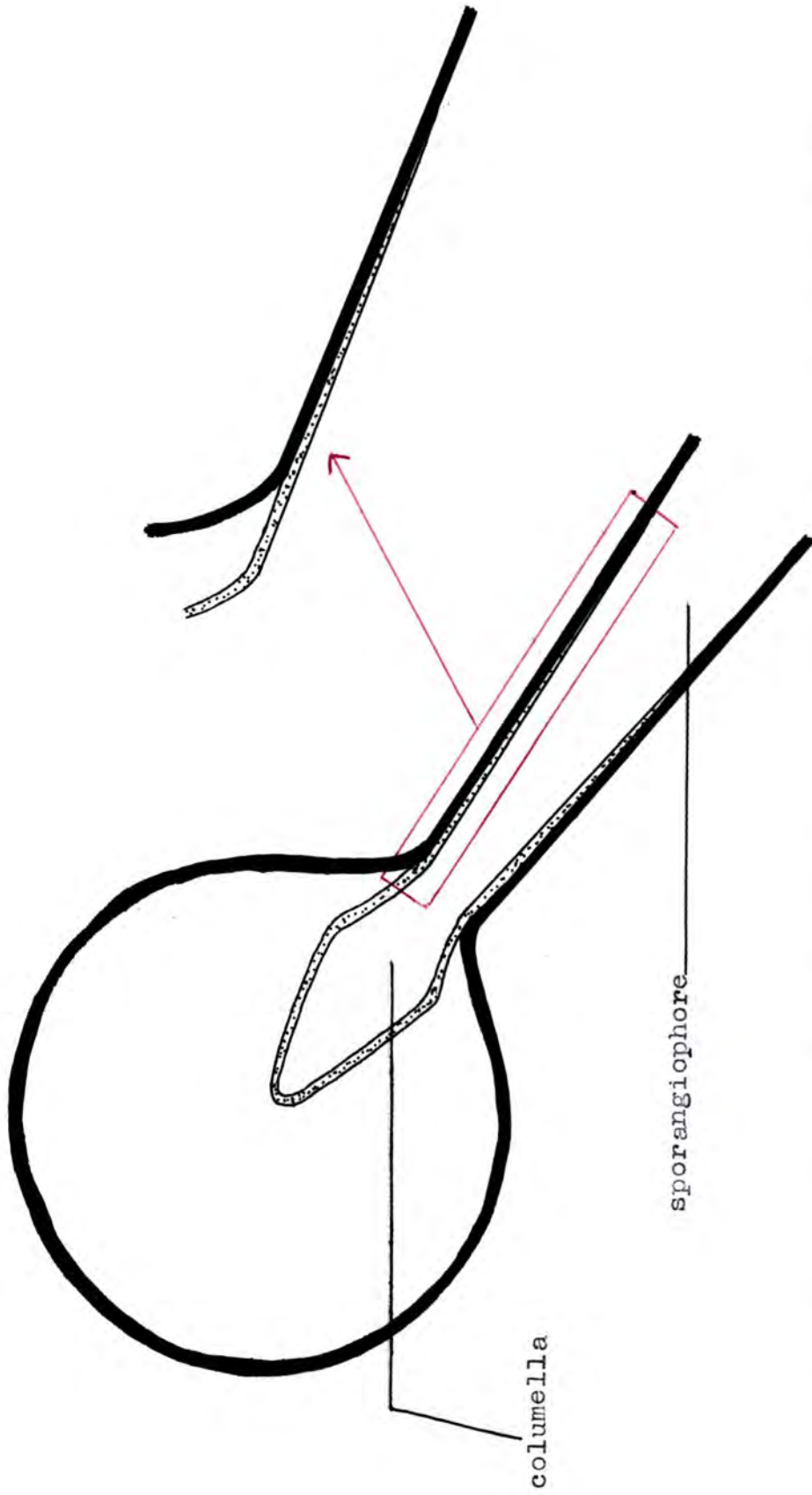

Fig.18. Longitudinal section of a mature sporangium to show the union of the columella wall with the wall of the sporangiophore

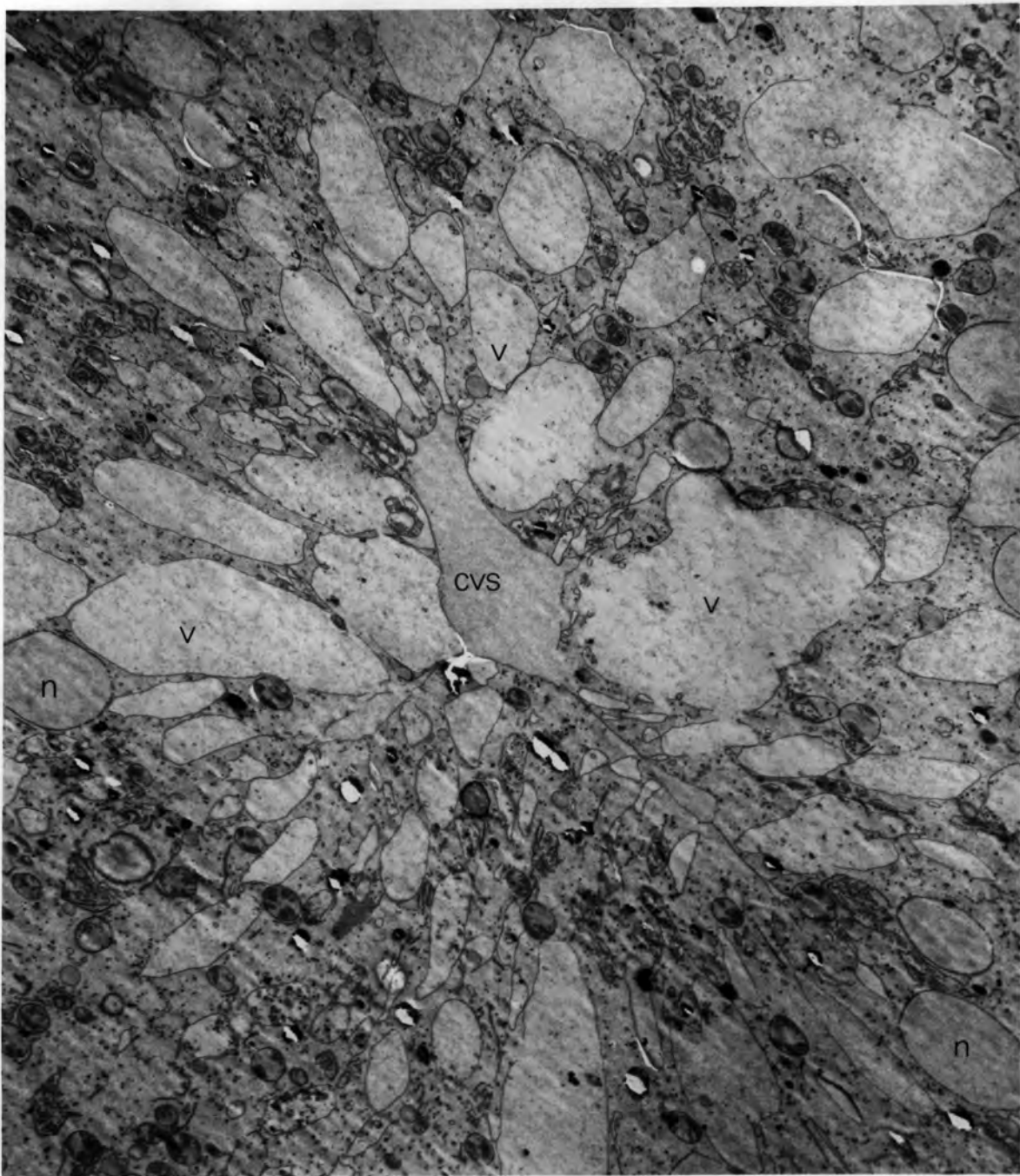

Fig. 19. Transverse section of the growth zone 0.5 mm below the sporangium of a Stage IV B sporangiophore showing numerous small vacuole and the central vacuole X 5,600.



Fig. 20. Central vacuole of sporangiophore 1 mm below the sporangium. The cytoplasm vacuoles are less numerous than in Fig. 19 X 6,800

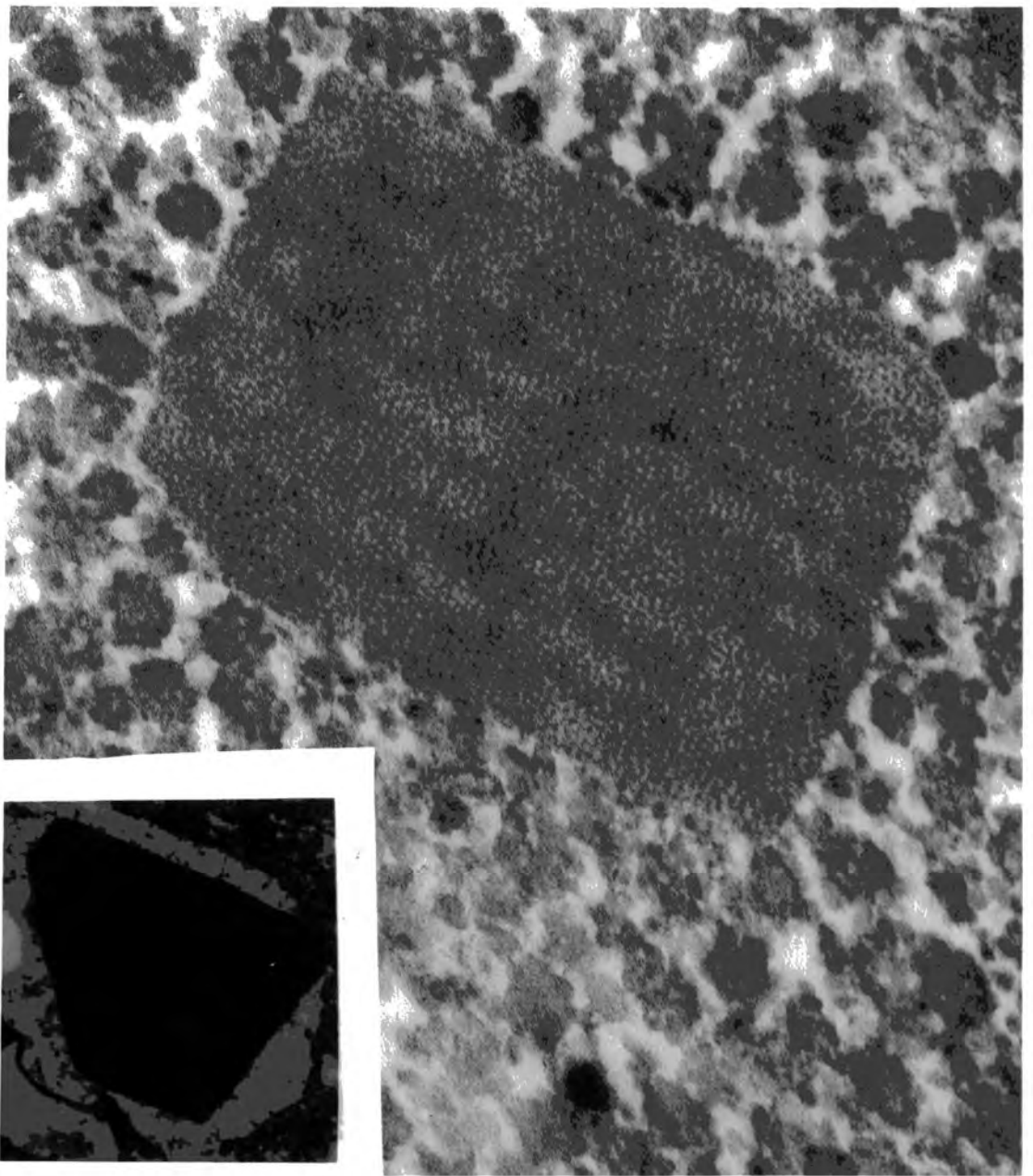

Fig. 21 Rhomoidal crystal in the cytoplasm. The crystal is approximately 1.07μ between the more widely separated vertices and 0.95μ between the other vertices. The crystal lattice is seen as intersecting electron dense lines.

X 115,000

Inset A vacuole crystal. Note the different profile. Gluteraldehyde fixation.

X 21,560

Their presence in relatively large numbers in the vacuole of the older parts of Phycomyces sporangiophores, which in the Stage IV B development have little need of storage material, might perhaps more satisfactorily be interpreted as a means by which waste materials are removed from the cytoplasm and deposited as harmless insoluble substances.

There is no organised distribution of cytoplasmic organelles within the growth zone. Mitochondria nuclei, glycogen granules, fat droplets bound with a crystalline layer of ferritin molecules forming a two dimensional pattern over the surface (Peat and Banbury 1968) (Fig.22), vesicles of several forms and layers of membrane have a random distribution (Fig.23).

Pockets of vesicles causing numerous invaginations of the plasmalemma are of frequent occurrence. These very much resemble the lemasomes originally described by Mohr and McAlear (1961)(Plate 24).

VIb (ii) Primary Gravity Receptor

The possibilities for a primary gravity receptor for the long term geotropic response were:-

1. The sedimentation of particles - this was not likely because of the rapid streaming of protoplasm within the sporangiophore which would tend to disturb any concentration gradient induced by gravity.
2. The shifting of the large central vacuole.
3. The redistribution of the vesicle system.

VIb (iii) Examination for the Primary Gravity Receptor

Petri dish and oxid cap cultures of Phycomyces blakesleeanus grown on 2% malt agar bearing Stage IV B

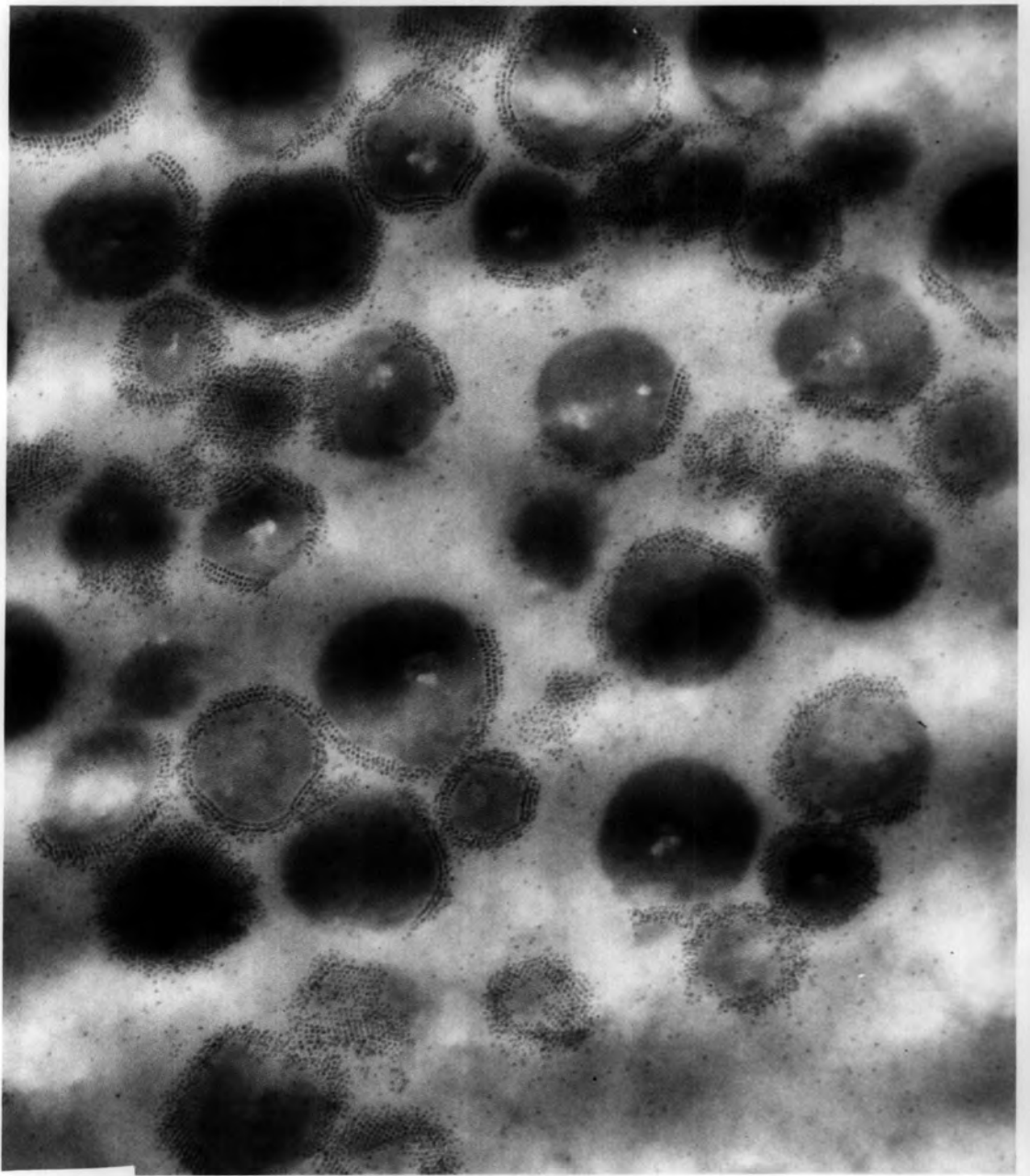

Fig. 22. Ferritin bound to lipid droplets in the cytoplasm of the growth zone of Stage IV B sporangiophore. Note the two dimensional crystalline pattern
Gluteraldehyde fixation. X 82,500

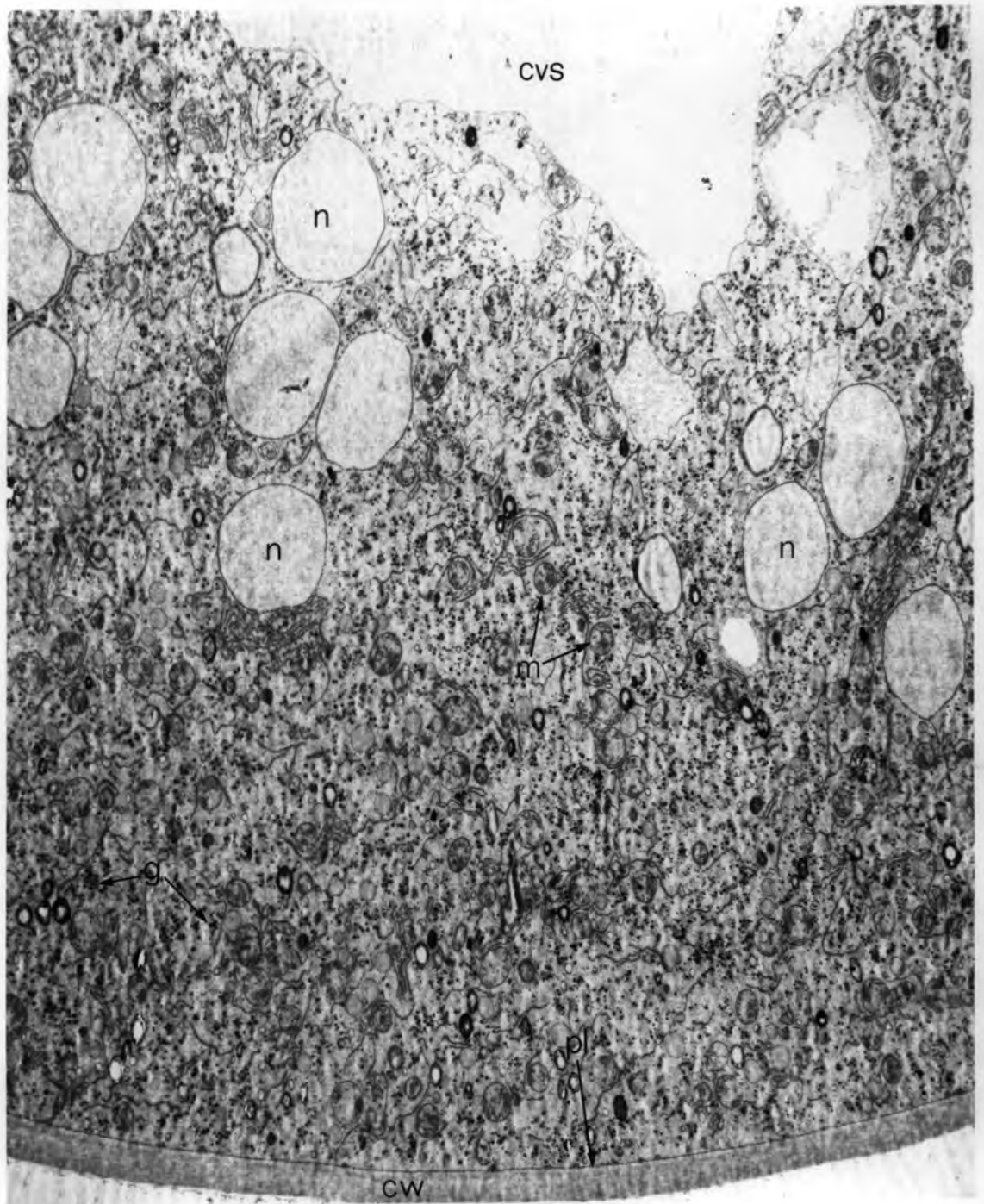

Fig. 23. Transverse section of growth zone of Stage IV B sporangiophore. KMnO_4 fixation. X 5,780

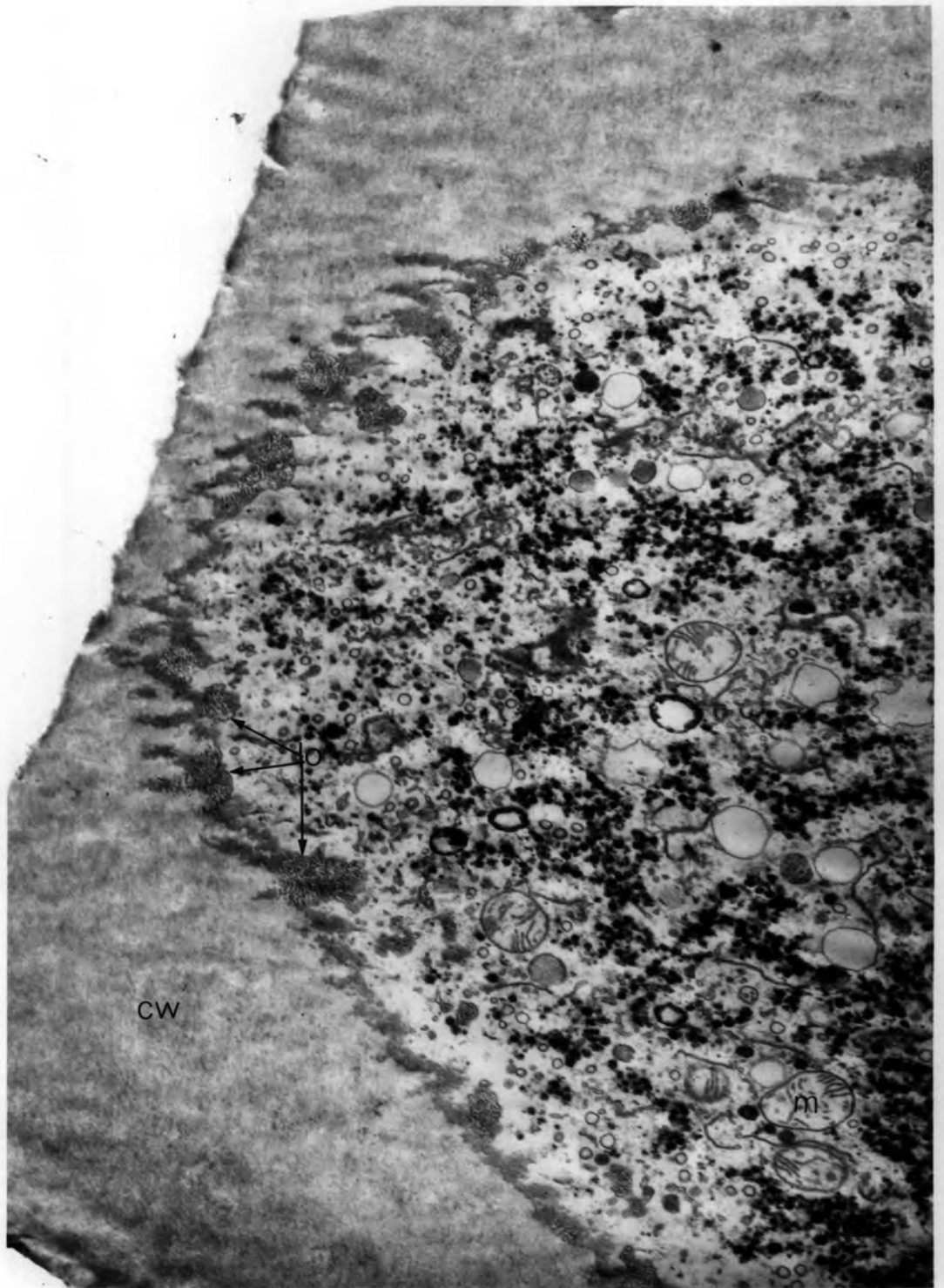

Fig. 24. Oblique section of growth zone of Stage IV B sporangiophore 0.5 mm below sporangium. Note the large number of 'lomasome-like' bodies associated with the plasmalemma and cell wall. KMnO_4 fixation. X 13,400

sporangiophores between 20-25 mm in height and standing vertically were treated as follows:-

All sporangiophores markedly less than, or greater than 20-25 mm in height were plucked from the cultures. Some petri-dish cultures to be used as controls were placed in the dark and left to continue vertical growth for a period of 2 hours.

Other petri dish cultures were placed in the dark and turned so that the sporangiophores were lying with them along the axes making an angle of approximately 90° to the force of gravity.

The oxid cap cultures were placed in the dark for 2 hours and then fitted with Morton closure caps to protect them from air currents during centrifugation. They were then placed on the centrifuge table in supporting cavities position 2 (Fig.25) i.e. 5.08 cm from centre of force and position 3 (Fig.25) i.e. 7.62 cm from centre of centrifugal force. The relative centrifugal forces at these positions were calculated as follows:-

$$\text{Centrifugal force} = \frac{M \times 4 \pi^2 \times N^2 \times R}{M \times g}$$

where M = mass; N = revolutions per second; R = radius and g = acceleration due to gravity = 980.6 cm/sec/sec and where:-

Position 2 (Fig. 25)

(a) When the disc was centrifuged at 200 R.P.M. the relative centrifugal force = 2.29 g.

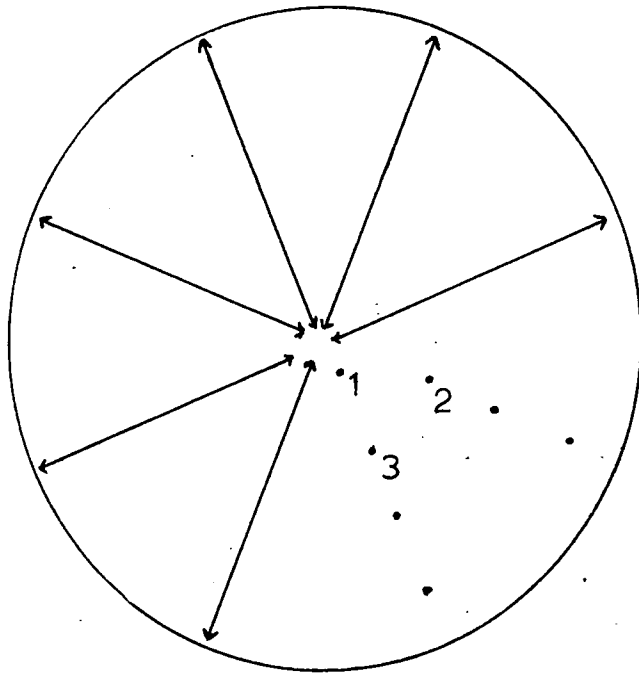

Fig. 25a. Surface view of centrifuge table to show relative positions of holes drilled to take the 'oxoid cap' cultures (shown on two radii only)

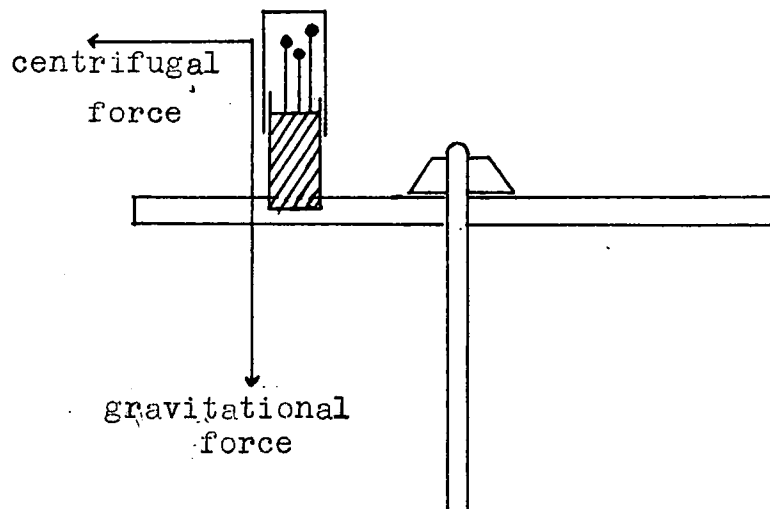

Fig. 25b. Side view of centrifugal table - only one culture tube is shown

(b) When the disc was centrifuged at 300 R.P.M. the relative centrifugal force = 5.13g.

Position 3 (Fig. 25)

When the disc was centrifuged at 200 R.P.M. the relative centrifugal force = 3.43g.

The sporangiophores were centrifuged at approximately

(a) 2.3 g for 30 mins

(b) 5.1 g for 15 mins

(c) 5.1 g for 30 mins

An absolute positioning of the sporangiophores relative to the axis of rotation was not possible because of the need to obtain sufficient material for electron microscopy. However all the sporangiophores used were positioned within a radius of 1 cm from the midpoint of the culture discs.

Preparation of Material for Electron Microscope examination.

The curvatures produced in the sporangiophores in response to gravitational and centrifugal stimulation remained throughout the subsequent preparation of the material for electron microscopy, and it was thus possible to make accurate orientation of the specimens to ensure that true transverse sections across the curvature were obtained during sectioning (fig. 26). The block was marked on the outer side of the curvature to enable immediate identification when the sections were examined under the microscope (Fig. 27).

Preparation of Thick Sections.

Sections 1 μ thick were transferred to microscope slides by means of film loops, dried onto the slides and

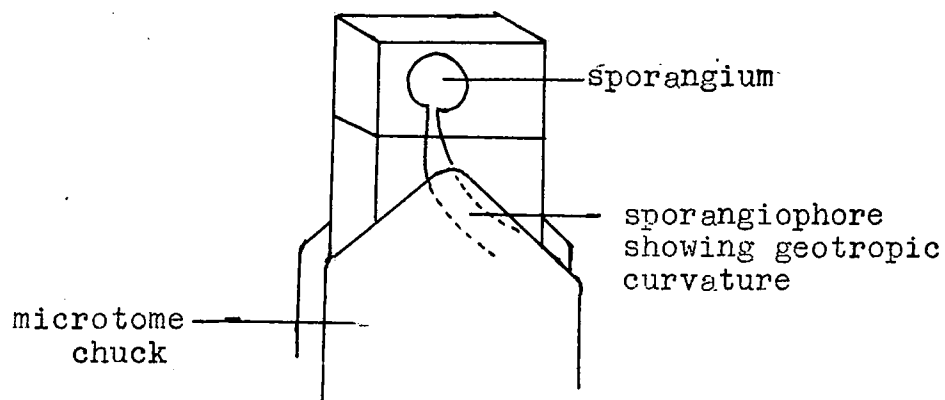

Fig. 26. Resin block in position in L.K.B. chuck ready for trimming

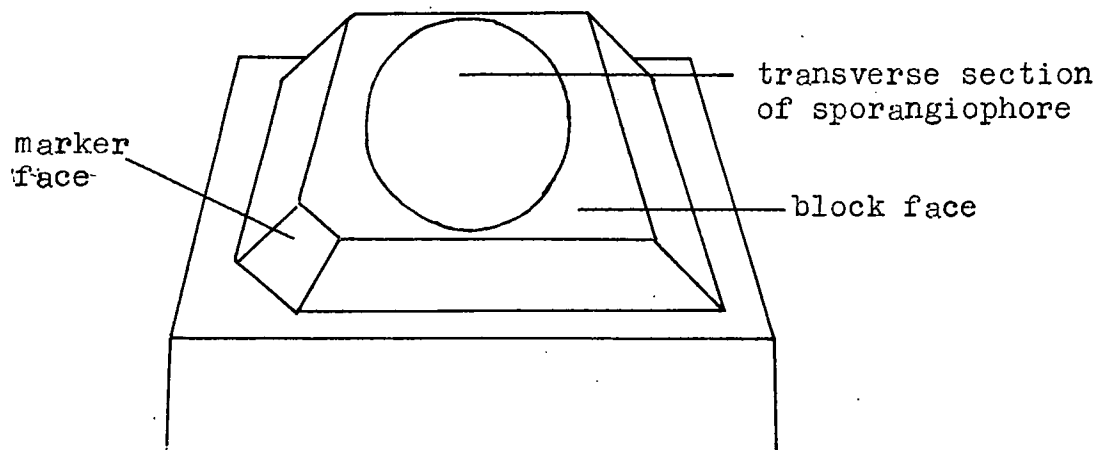

Fig. 27. Trimmed block ready for sectioning showing marker for outer edge of geotropic curvature in sporangiophore

then stained by warming in 1% Toluidine blue in borax for several minutes. Following staining, the sections were then rinsed under running water, air dried and mounted in Euparal

Vic Results.

After reaching the required centrifugal force by gentle acceleration for about 2 mins. the cultures experienced a steady force that was both centrifugal and gravitational in origin, resulting from the vectorial addition of a component originating from centrifugal acceleration and another from the gravitational pull.

N.B. The magnitudes of all gravitational force expressed as multiples of the acceleration due to gravity (980 cm/sec^2) to which the sporangiophores were subjected, were selected on the basis of Dennison's work (1961).

In the sporangiophores centrifuged at 5 g for 5 mins inward curvatures (Fig.28) in the growth zone of 35° to 37° from the vertical were measured and because of selection showed a remarkably uniform response. These were in agreement with Dennison's calculations of "transient" tropic bending speed of $5^\circ/\text{min}$ for the active phase of the transient growth response exhibited when the sporangiophores are subjected to a change in the centrifugal force. The direction of the curvature was related to the direction of change of the centrifugal force in that it was always opposite to it. Thus the direction of curvature was inward as the centrifugal force was raised from 1 g to 5 g.

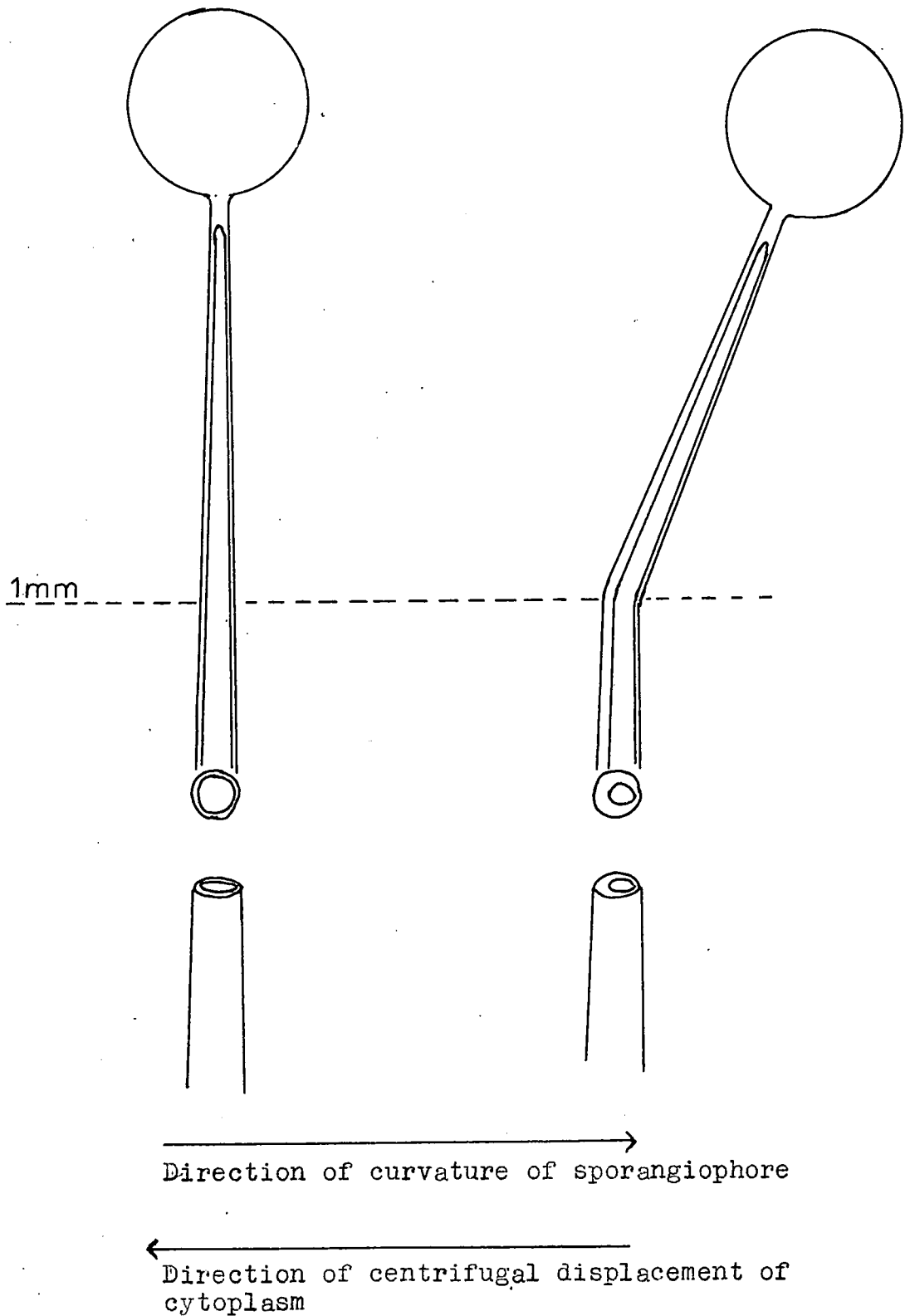

Fig. 28. Sporangiophore centrifuged at $5g$ for 5 mins produced an inward curvature of 35° to 37° from the vertical.

Results of Examination of thick sections.

The prepared sections were examined under a Baker phase contrast microscope at magnification of X 100 and X 400

Sporangiophores centrifuged for 5 mins at 5.1 g

Examination of thick sections showed a well pronounced asymmetry in the distribution of the cytoplasmic mass between 1.5 mm and 2.0 mm below the sporangium base. In this area there was approximately three times the depth of cytoplasm on the outside of the resultant curvature, as compared with that on the inside. (Fig.29). This asymmetry was presumably the result of an outward displacement of the cytoplasm and an opposite and corresponding inward movement of the less dense vacuole.

The occurrence of this asymmetry between 1.5 mm and 2.0 mm below the sporangium base closely corresponds with the region of the maximum curvature of the active phase of the transient response curve at 1.5 mm below the sporangium base reported by Dennison (1961). There was no asymmetry of the cytoplasm in those parts of the sporangiophore lying outside the growth zone where secondary wall material was being deposited. (Fig.30).

Results of Examination of ultrastructural features.

Thin sections were cut from the same areas as the thick sections. These, after staining were examined under the electron microscope and numerous micrographs covering the whole area of each section were taken at 2.5 k. From these micrographs, which

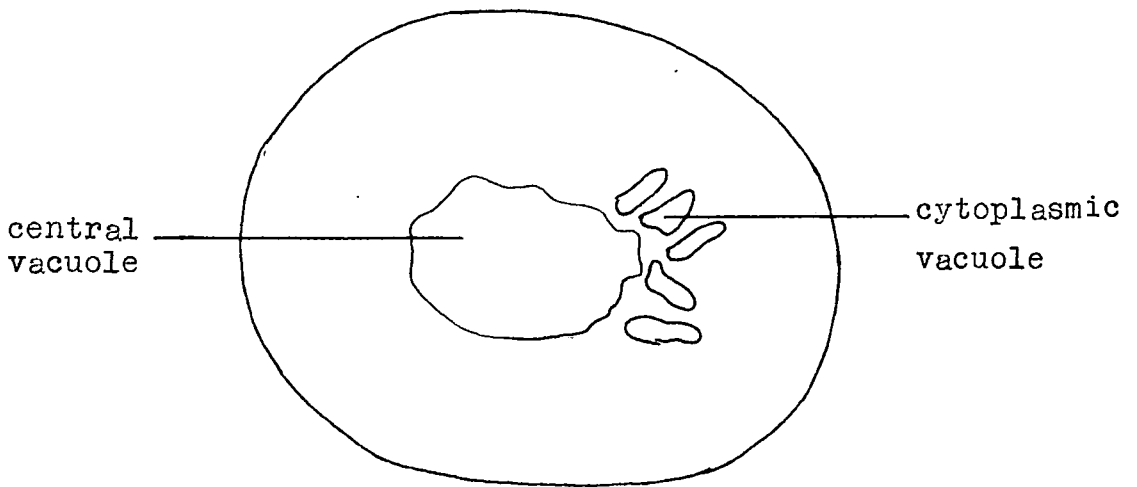

Fig. 29a Transverse section of a sporangiophore centrifugal at 5 g for 5 min. Section cut 1 mm below the base of the sporangium.

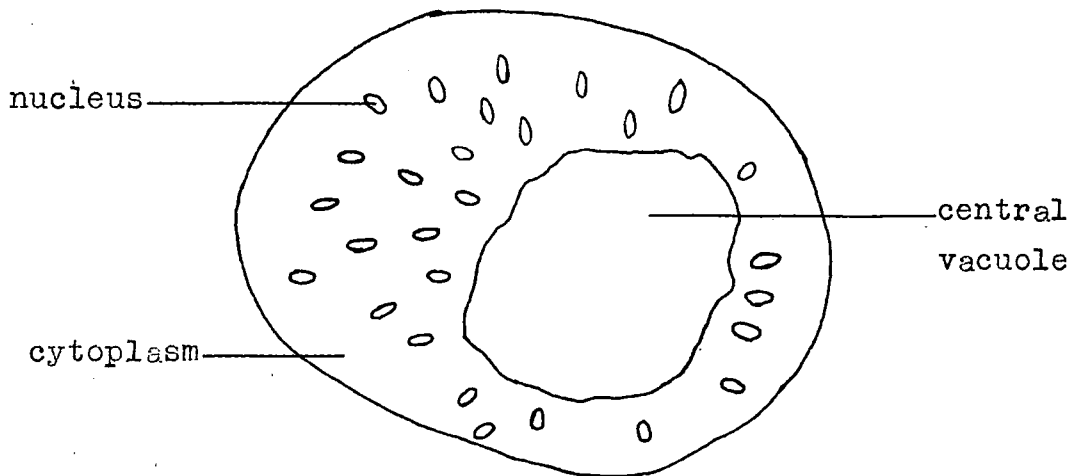

Fig. 29b Transverse section of same sporangiophore at 2 mm below the base of the sporangium. At this point there is a marked asymmetry of the cytoplasm. Camera lucida drawings

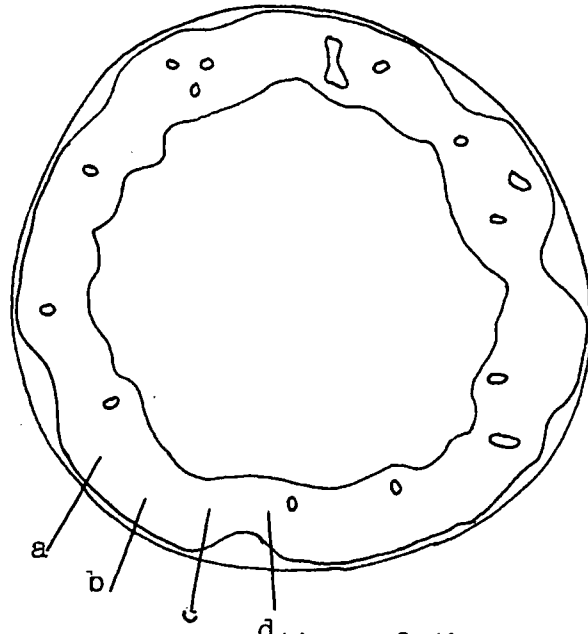

Fig. 30a. Transverse section of the same sporangiophore as Fig. 29 but taken 4 mm below the base of the sporangium. Note the absence of asymmetry of the cytoplasm. Camera lucida drawing.

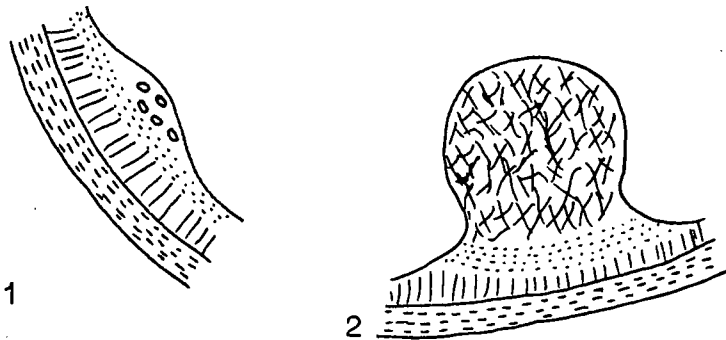

Fig. 30b. 1. Part of the sporangiophore similar to that between A-B, and 2. similar to that between C-D in Fig. 30a to show the deposition of secondary wall material between the primary wall and the plasmalemma. Drawings from electron micrographs such as Plates 34 and 35.

had at least 25% overlap in order to allow for spherical aberration, montages were prepared. These were examined carefully for organelle distribution. Examination of these montages taken at various levels within the growth zone of both the centrifuged material and that subjected to gravity, did not reveal any asymmetry of organelle distribution or any marked re-organization of organelles or inclusions. See Table IV for results.

VIc (i) Cytoplasmic Asymmetry in Centrifuged Sporangiohores

Dennison attributes the transient response to a mechanical distortion of the cell wall under the externally acting resultant force arising from the action of gravitational and/or centrifugal force on the relatively massive sporangium. He concludes that the resulting stretching or compression of the cell wall would stimulate or retard the rate of cell wall elongation. The transient response must however be a significant fraction of the total long term geotropic response.

It seems probable that the asymmetry of the cytoplasm that develops during the transient response might well be the triggering mechanism for the release of substances affecting the rate of cell wall growth on opposite sides of the sporangiohore, that results in the long term geotropic response, although it is not known whether any ultrastructural change can be recognized after brief stimulation by flexing, to produce a minimal transient response.

Distribution of Organelles in Normal and CentrifugedSporangiophores

Using a 5 cm square counts were made of the various organelles present in the cytoplasm on the inside and outside of the geotropic curvature.

TABLE IV A

Sporangiophore not subjected to Gravitational and Centrifugal Force. Samples taken at random.

Block 173a Section 5. Magnification 2.5K Diameter 180.8 μ

Number of Organelle in each 5 cm square

Micrograph No	1	2	3	4	5	6	7	8	9
<u>Organelle</u>									
Mitochondria	3	5	4	6	4	3	2	5	4
Nuclei	1	1	-	1	-	1	2	1	2
Fat droplets	6	4	4	1	3	1	4	4	3
Spherical vesicles	8	3	5	7	8	2	4	4	4
Small vacuoles 2.	-	3	4	1	3	3	4	4	1
Large vacuoles	-	-	-	-	-	-	-	-	-
E R	-	✓	✓	✓	✓	✓	✓	✓	✓

✓ = present; ✓✓ = abundant

Micrographs taken in sequence round tranverse section

TABLE IV B

Sporangiophore centrifuged for 5 g for 5 mins - Samples taken at random
Block 173d Section 5 Magnification 2.5k Diameter 6080μ

Organelle	Number of Organelles in each 5 cm square																
	Micrograph No -1	2a	2b	3	4	5	6a	6b	7a	7b	8	9	10	11a	11b	12a	12b
Mitochondria	4	4	4	5	4	3	3	6	3	2	5	10	7	6	6	9	8
Nuclei	1	-	1	-	-	-	1	1	-	1	-	-	-	-	-	-	2
Fat droplets	2	4	2	2	6	3	1	3	5	2	4	9	7	3	4	1	7
Spherical Vesicles	3	5	7	5	5	2	2	2	2	2	2	3	7	2	4	2	6
Small Vesicles	-	-	-	-	-	-	-	-	-	-	-	-	-	-	-	-	-
Large Vesicles	-	-	-	-	-	-	-	-	-	-	-	-	-	-	-	-	-
E R	✓	✓	✓	✓	✓	✓	✓	✓	-	✓	✓	✓	✓	✓	✓	✓	✓

Micrographs taken
on inside of
curvature

Micrographs taken
on outside of curvature

TABLE IV C

Counts taken from same section as Table B but from selected areas of the Cytoplasm on the outside of the Geotropic Curvature.

		Number of Organelles in each 5 cm sq.									
Micrograph No -		8		9		10		11		12	
<u>Outer Middle</u>	Mitochondria	5	3	9	4	5	5	5	7	10	6
	Nuclei	-	-	-	1	-	-	-	-	-	-
	Fat droplets	2	3	2	4	4	9	5	6	2	7
	Spherical vesicles	4	1	5	1	3	3	4	2	-	1
	Small vesicles	-	-	-	-	-	-	-	-	-	-
	Large vesicles	-	-	-	-	-	-	-	-	-	-
	E R	-	-	-	-	-	-	-	-	-	-
<u>Inner Middle</u>	Mitochondria	1	7	-	2	3	2	5	9	8	4
	Nuclei	1	-	-	1	-	1	-	-	-	1
	Fat droplets	6	1	5	2	8	4	5	6	3	9
	Spherical vesicles	1	2	1	2	4	2	5	1	13	4
	Small vesicles	-	-	-	-	-	-	-	-	-	-
	Large vesicles	-	-	-	-	-	-	-	-	-	-
<u>Inner</u>	Mitochondria	-	3	-	3	1		2	-	3	2
	Nuclei	1	-	-	-	-		1	1	-	2
	Fat droplets	-	3	-	2	-		5	4	1	-
	Spherical vesicles	-	1	-	3	-		-	3	1	1
	Small vesicles	-	-	-	-	-		-	-	-	-
	Large vesicles	-	-	-	-	-		-	-	2	-

TABLE IV D

Counts taken from same section as Table IV B
but from selected areas of the Cytoplasm on
the Inner side of the Geotropic Curvature.

Number of Organelles in Each 5 cm Square.

Middle layer	Micrograph No.	1	2	3	4
	Mitochondria	2	4	2	4
	Nuclei	1	-	1	1
	Fat droplets	3	5	5	4
		-	1	-	2
	Small vacuole	-	-	-	-
	Large "	-	-	-	-
	E R	✓	✓✓	✓	✓✓
Inner layer					
	Mitochondria	1	1	1	
	Nuclei	-	1	-	
	Fat droplets	-	2	6	
		-	-	-	
	Small	1	-	-	
	Large	-	-	-	
	E R	✓✓	✓	✓	

VIc (ii) Absence of Organelle Asymmetry

The absence of asymmetry of organelle distribution in sporangiophores subjected to gravitational and centrifugal forces are in agreement with the findings of Zalokar (as reported by Bergman et al) when he attempted the intra-cellular centrifugal separation of the organelles in the Stage I sporangiophore. Zalokar found that centrifugal forces of about 50,000 g were necessary to obtain separation of organelles from cytoplasmic connections.

It is therefore most unlikely that the mechanism of geoperception is based on differential sedimentation of organelles. The role of sedimentation, relative viscosities of organelles and inclusions in geoperception has been critically discussed by Audsø (1962)

VIc (iii) Lomasome Development

In Sporangiophores subjected to a steady force of either 1 g for 2 hours, 5 g for 30 mins or 2 g for 30 mins or more the asymmetry of the cytoplasm was not so well defined but did nevertheless exist.

In these sporangiophores however, particularly those centrifuged at 2 g for 30 mins or more there was found to be an extensive increase in the lomasome-like bodies on the outside of the resulting curvature (Fig.31) when compared with :-

- (a) the lomasome-like bodies of the vertically grown sporangiophore
- (b) the lomasome-like bodies on the inside of the curvature (Fig.32). Lomasome-like bodies were also present between the plasmalemma and sporangiophore

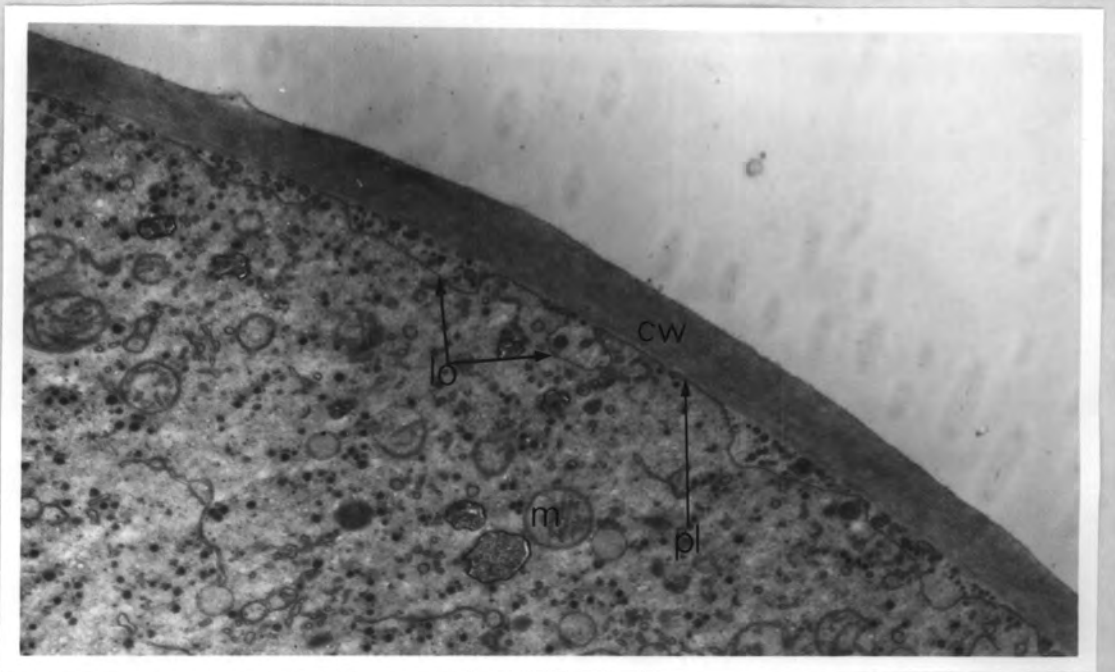

Fig. 31 Extensive development of lomasome like bodies between the cell wall and plasmalemma on the outside of the geotropic curvature

UNIVERSITY OF CHICAGO
31 OCT 1972
BOTANICAL LIBRARY

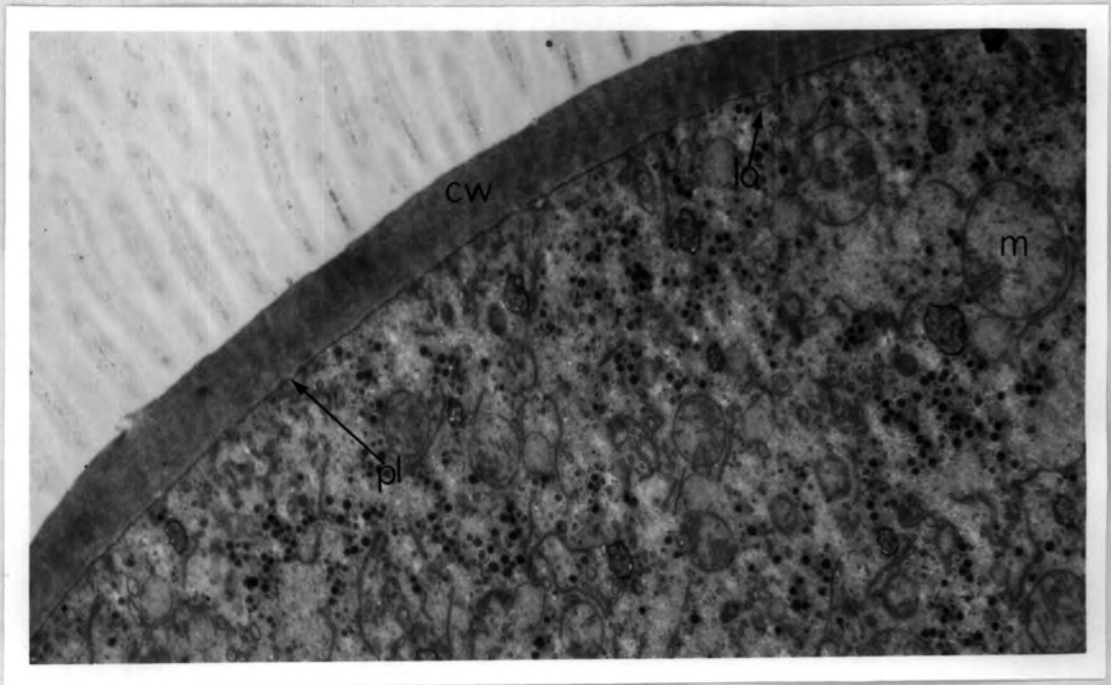

Fig. 32 'Lomasome-like' bodies between the cell wall and plasmalemma on the inside of the geotropic curvature

UNIVERSITY OF
 GUELPH
 31 OCT 1972
 SECTION
 LIBRARY

walls in those regions of the sporangiophore where secondary wall material was being deposited (Fig. 33). In these regions several extremely large plasmalemma invaginations were observed (Fig. 34.) Moore and McAlear suggested that these bodies might play some role in the building of cell walls.

Discussion

Autoradiographic studies (Barton 1968) however showed that in Chara species, which possessed lomasome-like bodies, when the cells are provided with tritiated glucose it is the Golgi apparatus in which the glucose appears before being extruded in the Golgi vesicles and taking up its final position in the cellulose fibres of the wall.

Despite Barton's findings and his suggestion that lomasomes are probably of no significance in wall synthesis, the presence of these lomasome-like bodies in regions of active hyphal wall growth, their apparent absence in non-growing regions and their extensive development close to the outer wall of the geotropic bend, where one would expect increased wall synthesis, strongly suggests that they play some role in wall synthesis of the sporangiophore of Phycomyces blakesleeianus and that they play some part in bringing about growth responses. Heath and Greenwood (1970) as a result of their investigations on Saprolegnia ferax and Dictyuchus also suggested that lomasomes and plasmalemmasomes may not be involved in wall synthesis. However the two organisms used by them were both oomycetes which like Chara possess a substantial proportion of cellulose in the cell wall. They may



Fig.33 Transverse section of a sporangiophore centrifuged at 5 g for 5 min, 4 mm below the sporangium. Note the development of secondary wall material and the presence of 'lomasome' like bodies. X 7,180

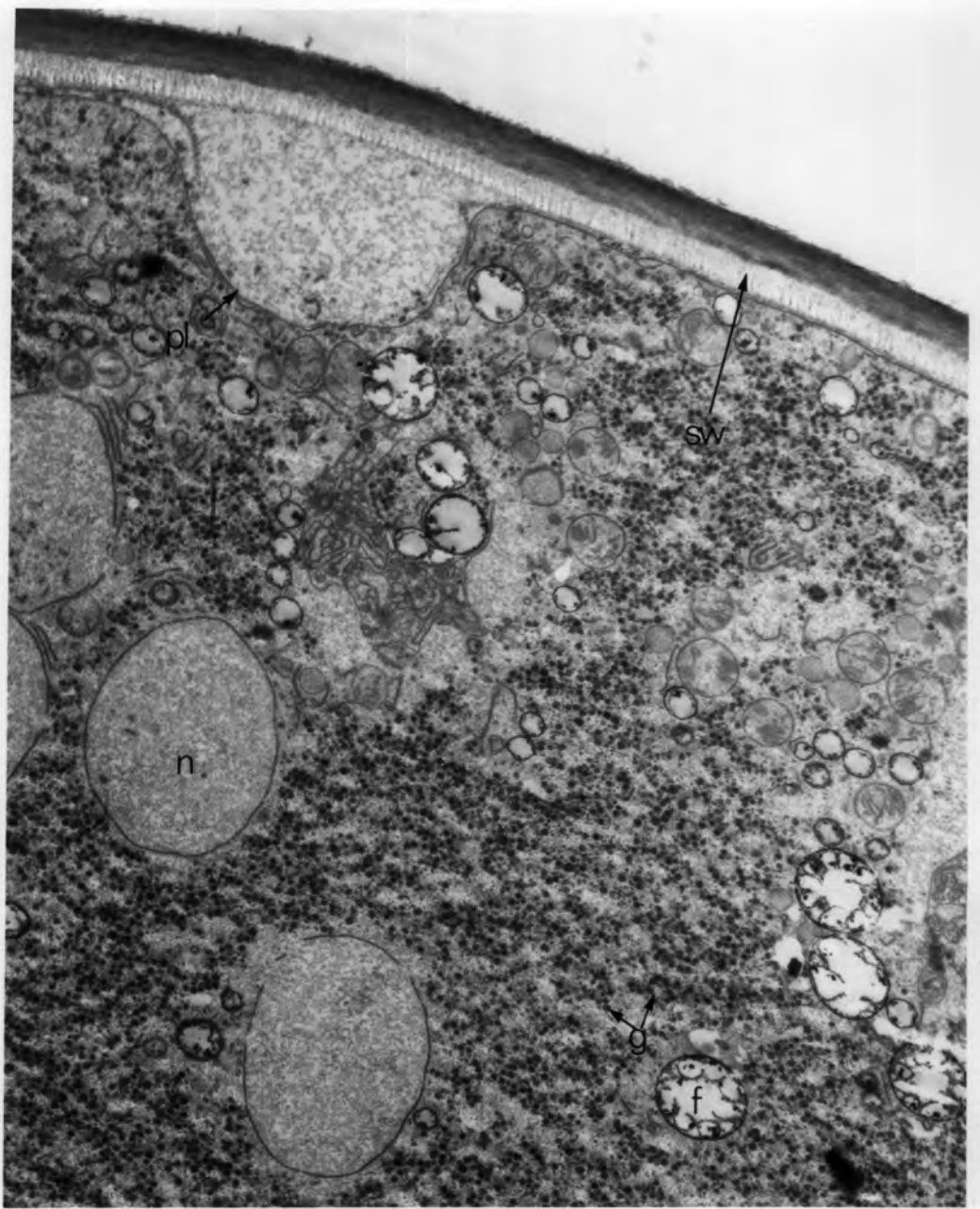

Fig. 34. Extensive invagination of plasmalemma in region of secondary wall development. Sporangiochore centrifuged at 5 g for 30 min. X 7,180

therefore possess a closer affinity to Uhara in their mechanism of wall synthesis than they do to most other fungi which, like Phycomyces, have cell walls containing a substantial proportion of chitin.

The electron microscope evidence so far obtained for the mechanism of cell wall growth in Phycomyces blakealeeanus is somewhat confusing. The presence of both microfilaments passing from the cytoplasm into the cell wall and 'lomasome-like' bodies between the cell wall and plasmalemma suggest the involvement of a two phase system leading to the final deposition of wall material and the associated spiral growth of the sporangiophore. Future autoradiographic studies may help to verify the precise mechanism of wall synthesis in Phycomyces sporangiophores.

Section VII

Photoreception in Phycomyces

VIIa. Historical.

The earliest investigations on the light growth responses of Phycomyces sporangiophores were made by Blaauw (1914) and later confirmed by Castle (1932), who observed among other things that there was a marked but transient increase in growth rate when sporangiophores were symmetrically illuminated from two or more sides. Blaauw (1918) developed a theory for the phototropic response of the Phycomyces sporangiophores. He interpreted the unequal growth that leads to a phototropic curvature as a result of an unequal light growth reaction in the proximal and distal sides of the unilaterally illuminated sporangiophore. He supposed that in the sporangiophores of Phycomyces there would be a tendency for light to focus on that side of the sporangiophore away from the source and this would consequently give a stronger positive light growth reaction on that side thus bringing about a positive phototropic curvature. Such a process would not increase the total amount of light received by the back wall but would only alter its spacial distribution. Castle (1933) assumed that the absorbing pigment was not located in or near the sporangiophore wall but was uniformly distributed throughout the protoplasm. He pointed out

that due to refraction, the average length of path traversed by the light in the back half of the sporangiophore is about 20% greater than that traversed in the front half. Therefore the nett absorption in the back half might well be in excess of that in the front half of the sporangiophore if the attenuation of intensity during traversal is slight.

According to Banbury (1959) Buder argued that Castle's assumption of a uniform absorption of light throughout the cytoplasm was an unlikely one. Allowing that the total influx of light reaching the back wall of the sporangiophore will not be greater than that striking the front wall, but in fact must be somewhat smaller, Buder argued that due to lens action photoreception would be concentrated in a narrow zone in the back wall resulting in a narrow concentrated growth reaction. This, Buder argued, would give the growth response in the back wall a mechanical advantage over the uniformly distributed one in the front wall.

However Delbrück and Reichardt (1956) point out that none of these theories account for the fact that the phototropic response must be extremely localised at the base of the growth zone, since without such localisation the spiral growth so characteristic of Phycomyces together with the tropic response would cause the growth zone to bend into a helix. Delbrück and Reichardt (1956) showed by means of stimulating short sections of the growth zone and measuring the growth response that there

was an independent response in each fraction of the growth zone. The full response of the totally stimulated growth zone was the sum total of the response of each component part of the zone. They were however unable to explain why the latent periods between the stimulation of the various zones and the responses are all alike if each stimulation produces its response at the base of the growth zone, although it is not impossible that stimulation leads to conduction of the stimulus to the base of the growth zone.

Banbury obtained results which supported the deduction of Delbrück and Reichardt that the tropic response is confined to the base of the growing zone. He obtained a phototropic curvature, in Stage I sporangiophores illuminated by a very narrow grazing pencil of light, which was in a plane almost perpendicular to the beam and at a distance of a millimetre or more behind the region of wall surface actually illuminated. There is thus a strong indication that there is a downward transmission of the stimulus although the experimental evidence is far from conclusive.

VIIb The Photoreceptor.

Numerous attempts have been made to identify the photoreceptor. Studies to find it have been based on the action spectra of the sporangiophores and, as a result of these, β -carotene, retinal attached to a protein, or a flavoprotein have been suggested as likely receptor pigments. These compounds

have light absorption spectra which closely resemble the action spectra of the phototropic curvature.

In vivo measurements through the growing zone of single sporangiophores show that β -carotene is the main absorbing pigment in the 400-500 nm region of the visible spectrum (Zankel, Burke & Delbrück 1967). Its absorption spectrum is very close to the action spectrum although displaced 5-10 nm to the red. There have, however, been several pigment mutant strains of Phycomyces discovered containing less than 1/1000th of the β -carotene possessed by the wild type which are still fully photosensitive (Meissner and Delbrück 1968). These findings indicate that the bulk of the β -carotene is not the effective pigment, but do not necessarily mean that it plays no part in photoreception. The mutant type sporangiophores have been estimated to possess about 10^{10} molecules of β -carotene per sporangiophore while the requirements for effective tropic responses have been estimated at about 3×10^9 molecules of receptor pigment per growth zone (Bergman et al 1969). It is thus still possible that some specialised form of β -carotene may play some part in photoreception.

Retinal as a receptor pigment is most unlikely since wild type sporangiophores contain very small quantities, between 10^9 and 10^{10} molecules per sporangiophore which is about 1/10,000th that of the β -carotene content. Attempts to find retinal protein complexes which liberate retinal on exposure to light have proved negative and no retinal was found in the β -carotene

mutant car 5 which shows a phototropic response (Bergman et al 1969).

Wolken (1969) obtained two distinctly different absorption spectra for the growing zone 0.1 to 3 mm below the base of the sporangium. One he found to be more characteristic of a carotene whilst the other was more characteristic of a flavin. When the absorption spectra were combined they reproduced very closely the action spectrum for the phototropic response. In the albino car 10 (-) which is deficient in carotenes, only the spectrum characteristic of 2 lumichrome or a reduced flavine was found. In both the wild type and albino car 10 (-) a c type cytochrome was isolated which if coupled with a flavin could permit a photo reversible oxidation - reduction system.

Wolken also observed birefringent crystals aligned in the growing zone in which the photoreceptor is believed to lie. Using microspectrophotometry he was able to show that the absorption peaks of these crystals were similar to those of riboflavin crystals and to the absorption spectra of the sporangiophore. These facts together with the isolation of a cytochrome suggested to Wolken a possible scheme which would provide a photo-reversible system such as from the oxidised yellow riboflavin via cytochrome and light to the reduced colourless form. He also suggests the possible conversion of riboflavin in light and acid pH to lumichrome. It therefore seemed to me well worth while to attempt to determine the frequency of occurrence and distribution of such crystals with the electron microscope.

As a result of his work Wolken strongly suggests that β -carotene does not appear to be the primary photoreceptor molecule although it or one of the other carotenes present in the sporangiophore most likely functions as an accessory pigment molecule.

Heuckel (1927) claimed to have observed a greater density of protoplasm on the far side of unilaterally illuminated sporangiophores, than on the near side in Mucor mucedo and in Pilobolus crystallinus. Banbury (1952) was not able to detect any asymmetry in opacity in living sporangiophores of Mucor mucedo or Phycomyces blakesleeanus during or immediately after unilateral illumination.

However, it was thought that small aggregates of photo-absorbing material might become arranged in the cytoplasm in a distribution that was determined by the light flux and that a small concentration gradient might have important consequences in modifying the light absorption.

VIIc. Electron Microscope Investigation for a possible Photoreceptor

Method.

Cultures were grown in 2% malt agar in diffuse light at ambient room temperature until the sporangiophores were in Stage IV B of development, approximately 2 - 2.5 cm tall and growing vertically.

They were then transferred to the growth chambers in a dark room. In the growth chamber the sporangiophores were illuminated by one 6 volt 3 watt bulb on each of two opposite walls positioned so that the incident light

from each bulb made an angle of approximately 45° with the growth zone. They were left for 30 mins to adapt to the reduced light conditions. At the end of this period one light was turned off so that the specimens were now receiving unilateral illumination of half the intensity of the original symmetrical bilateral illumination. Within 30 mins the sporangiophores had produced a positive phototropic curve that was visible to the naked eye.

Preparation of Material for Electron Microscopy.

Once a visible curvature had been produced the sporangiophores were immediately plucked from the culture and prepared for electron microscopy in the same way as were the sporangiophores subjected to gravitational/centrifugal force.

The specimens were orientated in the chuck and sections were cut between 1.5 and 2 mm below the sporangium and stained as in the preparation of material being examined for a primary gravity receptor. (Section VI b iii)

VIIId. Results of Examination of Material

Examination of the thin sections under the electron microscope did not show any asymmetry of the cytoplasm on the illuminated and non illuminated sides of the sporangiophore and did not confirm Heuckel's view (1927) that there was a difference in protoplasmic density on the near and far sides of a sporangiophore showing a phototropic curvature.

Estimates of the organelle distribution on the far and near sides of the phototropic curvature gave

no evidence of any significant reorganisation of particular organelles. (Fig.35)

The only appreciable difference was that between the glycogen content of sporangiophores grown under normal daylight conditions and those under investigation. In the latter the glycogen content was significantly less than that of sporangiophores grown in normal daylight as judged by the electron density after staining.

VIIe. Discussion.

In consequence of these findings it seems most unlikely that photoreception has its origin in the organelle distribution of the growth zone. Despite Wolken's findings it also seems most improbable that the crystals, identified by means of their absorption spectra as being either riboflavin or a closely related compound, found within the sporangiophore are associated with photoreception. These crystals, which vary considerably in their size and form, appear to have no specific location within the sporangiophore. They were occasionally found within the growth zone, in large numbers in the older mature cytoplasm many millimetres behind the growth zone, and also in the large central vacuole. ^(Fig 36) The alignment of these crystals in the vacuole of the growth zone, as reported by Wolken (1969) was not commonly observed in my material. His findings may have been significant for his strains or may have been a matter of chance; they are not valid for my strain which gave a strong phototropic response.

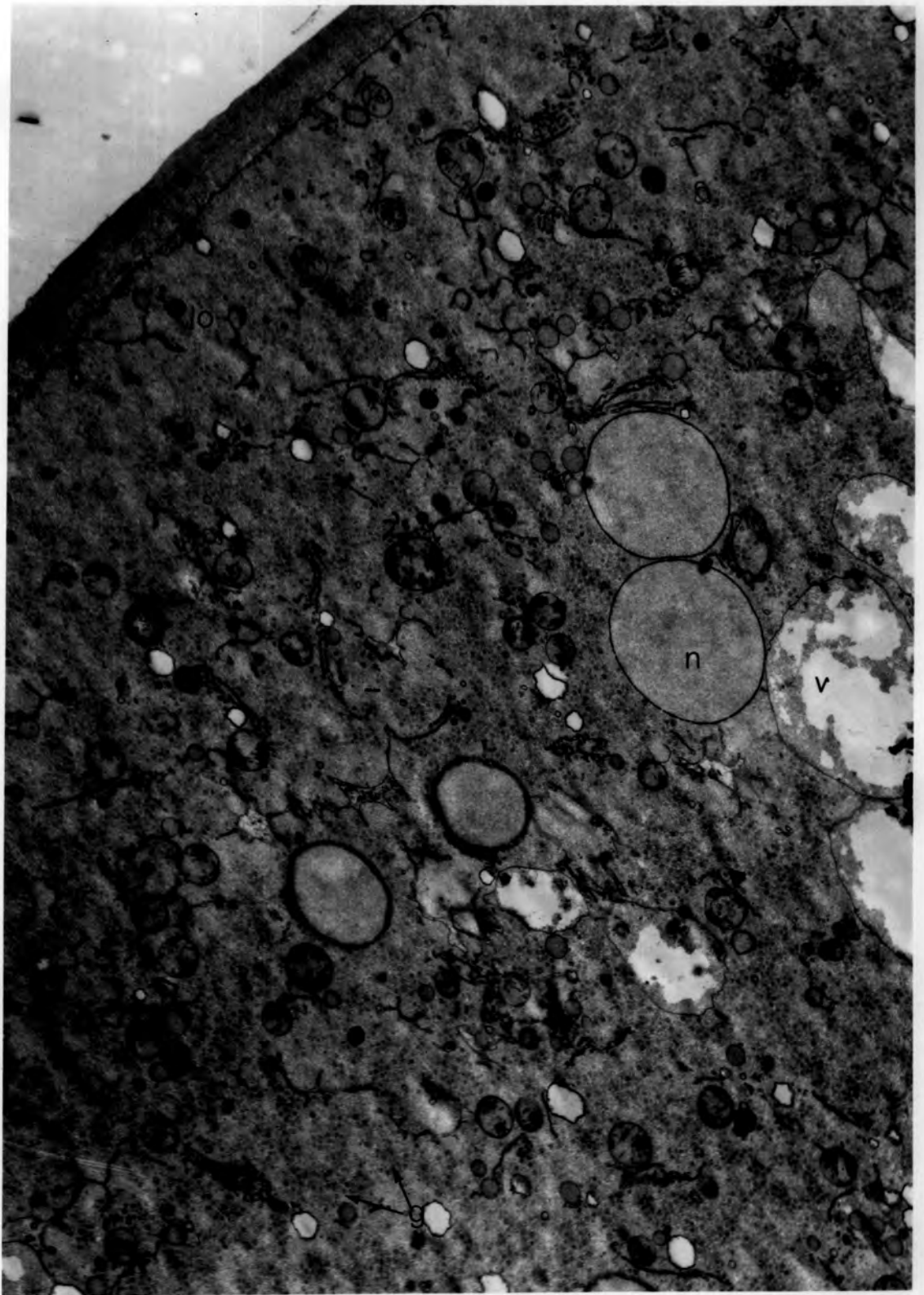

Fig.35. Transverse section of the growth zone of a sporangiophore unilaterally illuminated for 30 mins. Note the apparent absence of glycogen. X 7,500

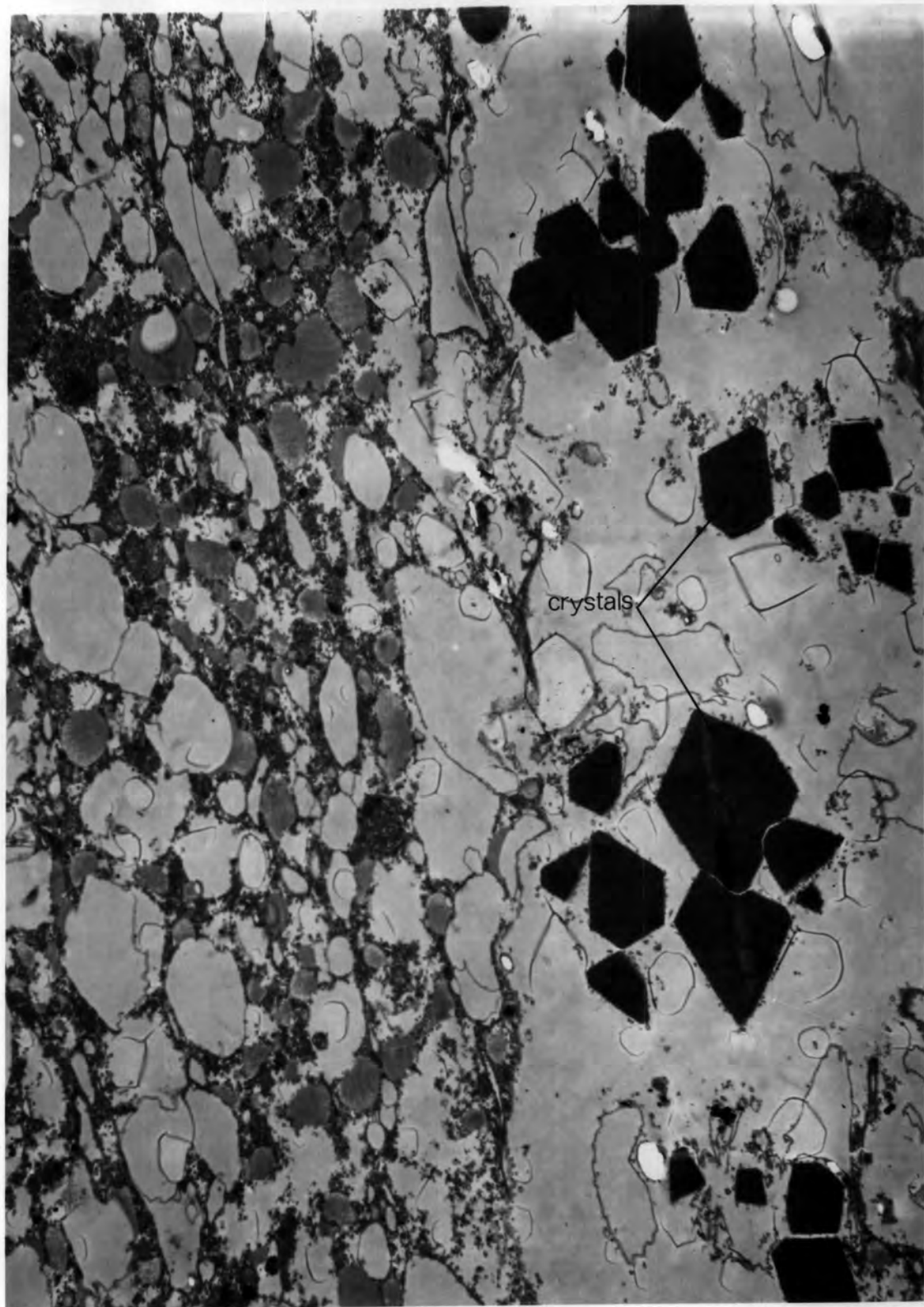

Fig.36. Crystals identified as riboflavin or closely related compound (Wolken 1969) in the vacuole of the mature region of a sporangiophore. Gluteraldehyde - Osmium fixation. X 6,250

This random distribution, especially within the vacuole, makes them far from suitable as photoreceptors.

The results of these preliminary experiments do not suggest that the photoreceptor of Phycomyces sporangiophores will be found in the macromolecular structure of the cytoplasm as revealed by electron microscopy.

Section VIII

Sporangium Development and Spore Germination

VIIIa. Review of Previous work on Sporangium Development

Columella formation

The earliest account that deals specifically with the formation of spores in the Mucorineae is that of Corda (1838)(as reported by Swingles 1903). He investigated the development of the Sporangium of Ascophora mucedo, now known as Rhizopus nigricans and gave us the first description of the method of columella and spore formation. He described the columella as "at first being slightly arched in the lower part of the sporangium and gradually pushing upwards into the sporogenous tissue". The spores he described as being formed in radiating rows from the columella. Although this method of columella formation was soon described as being "a matter of pure invention" on the part of Corda (Fresenius 1850-63) it was generally accepted and appeared frequently in the classical literature until well beyond the turn of the century.

According to Swingles an accurate and detailed description of the structure and development of a very large number of the Mucorineae was later covered in a series of papers by Van Tieghem (1873, 1875, 1876).

According to Schwarze, Brefeld (1872) studying Mucor mucedo described the columella as not being something

that is primarily flat and then becoming arched by increased pressure from below, but "has from the first instance an arched form which may subsequently and incidentally become modified". Similar descriptions of columella formation were made by several later workers (Leger 1896, Harper 1899, Swingles 1903 and Schwarze 1923).

Spore formation.

The method of spore formation in sporangia was studied by Pringsheim as early as 1859. It was however Van Teighem (1873, 1875, 1876), working on almost the entire group of zygomycetes, who first indicated that the spores may be formed by simultaneous division. He believed that the method of spore formation was the same in all genera producing a spherical sporangium. He observed that the sporogenous protoplasm of Sporadina separated itself into two very different substances. The spore-plasm which was always granular, condensed into small polyhedral portions which rounded off, secreted a cell wall and formed the spore, and the interspore-plasm which was always homogeneous and brilliant, and during spore formation dispersed itself so that it occupied all the spaces between spores and formed a layer between the outer spores and the sporangial wall.

Strasburger (1880) studying zoospore formation in Saprolegnia described spore formation as being simultaneous. "In den Zoosporangien der Saprolegnien wird, wie aus zahlreichen angaben bekannt, eine grosse Anzahl Schwarmsporen simultan aus dem gesamten Protoplasmatischen Inhalte des Sporangium gebildet" Similar accounts of simultaneous spore formation were given

by several other authors including Dangeard (1890) working with Synchytrium taraxaci, Cornu (1872) working with Olpidiopsis & Thaxter (1897) working with Syncephalastrum. (as reported by Schwarze 1923)

Schwarze (1923) however, claims, after studying cleavage in the sporangia of a number of fungi, that the evidence for simultaneous spore formation was far from adequate, but rather that there was an accumulation of evidence in support of the view that the process was a progressive one resulting from furrowing either from the periphery of the sporangia or from vacuoles within the spore-plasm.

Swingle (1903) made the first detailed study of spore formation in Phycomyces species, an account of which is given in a paper in which he compares the processes occurring in Phycomyces nitens with that occurring in Rhizopus nigricans. In this paper he gives a lucid account of the development of the cleavage vesicles, the zonation of the sporangial contents in the early stages of development, and the differentiation of the columella and spores, as seen in material prepared by using the mixtures of Flemming, Herman and Merkel as fixing fluids together with Flemming's triple stain. Swingle, however, claimed that the cleavage vesicles were present within the cytoplasm at the onset of sporangium development. He also claimed to have observed two layers in the sporangium wall from a comparatively early stage in development but only one layer in the wall of the sporangiophore. Another feature which Swingles describes in his paper, is the contraction of the spore-plasm during cleavage, a process he believes to be responsible for the enlargement of the cleavage vesicles and hence cleavage.

Numerous electron microscopical studies have to date been made on fungal material. Some of these have been concerned with spore germination. (Hawker and Abbott (1963) and Hawker and Hendy (1963), but only one detailed electron microscopical study of sporangium development has been made (Bracker 1966).

VIIIb. Sporangium Development in Phycomyces.

Two to three days after inoculation of a 2% malt agar plate with mycelium the culture is usually seen to possess sporangia in all stages of development. The developmental sequence can for convenience sake be divided into five stages (Fig.37)(Castle 1942 based on Errera).

Stages of Development.

Stage I. The Sporangiphore grows up from the mycelium as a simple tube tapering rather sharply at its apex, where it grows at a rate of 1-2 mm./hour. Unlike later stages the apex shows little, ~~if~~ any, rotation around the vertical axis.

Stage II. The onset of Stage II is influenced by a number of environmental factors which include the chemical composition of the medium and illumination. It represents a change in the morphology of the sporangiophore. The tip of the sporangiophore swells and a bright yellow sporangium is formed. During the enlargement of the sporangia, the sporangiophore does not lengthen or rotate.

Stage III. This is a period lasting for several hours during which there is neither sporangium enlargement nor sporangiophore growth.

Stage IVa. The sporangiophore resumes elongation and twists in an anticlockwise direction viewed from above.

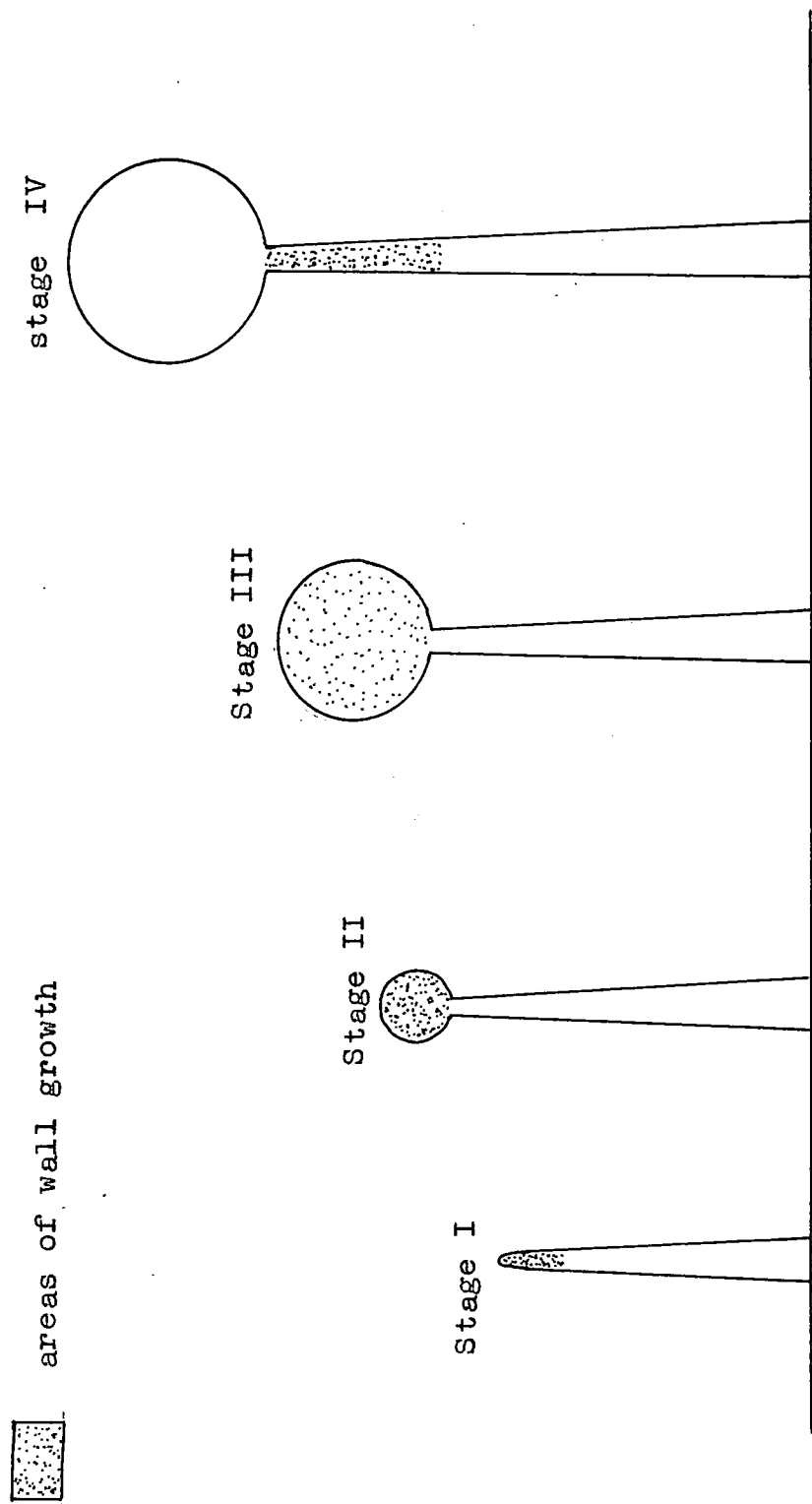

Fig. 37. Stages in development of the sporangium of *Phycomyces* (after Castle 1942)

The sporangium turns brown.

Stage IVb. About 90 minutes after the resumption of growth anticlockwise rotation slows down and is gradually replaced by rotation in a clockwise direction soon reaching a rate of one complete rotation in 30 minutes. The sporangiophore continues growth for many hours maintaining a steady rate, once attained, of about 3 mm per hour.

The apical zones of all stages of development were examined and during investigation very many sporangia were sectioned in several places.

VIIIc. Preparation of Phycomyces Sporangia for Electron Microscope Investigation.

Sporangiophores bearing sporangia at Stages 1-4 of development (Castle 1942) were plucked from the mycelium at the point of junction of the sporangiophores and mycelium. These were put in separate vials containing 2% KMnO_4 and one part per thousand of detergent. The material was left in the fixative for varying periods of time.

The fixation times were as follows:-

Stage I	1 hour
Stage II	2-4 hours
Stage III	5-6 hours
Stage IV	12 hours

These fixation periods were chosen after several trial attempts. Fixation using gluteraldehyde followed by post fixation with osmic acid was attempted but it gave extremely poor results.

After dehydration in a graded series of alcohols the Stage I sporangiophores and the sporangia were embedded in T.A.A,B. embedding resin.

Section of the order of 60nm in thickness were cut. After uranyl acetate and Reynold's lead citrate

staining these were examined and photographed on an A.E.I EM6B electron microscope.

VIIIId. Results.

(i) The Stage I apex.

The apical zone of the Stage I sporangiophore has been examined by Peat and Banbury (1967) and Thornton (1968). My findings were in general similar to theirs. At the growing tip is an area about 20 μm in length which is devoid of nuclei and possesses very few mitochondria, the latter only beginning to make their appearance at approximately 9.2 μm behind the apex. I was not able to confirm the findings of Peat and Banbury that these mitochondria differed markedly in the form of their cristae from those in other regions of the hyphae. The plasmalemma in this apical region is extremely irregular often showing extensive and much folded ingrowths passing deep into the cytoplasm. The cytoplasm within the first 9 μm contains numerous small pieces of membrane forming a variety of configurations within the ground plasm. The wall of the hyphal apex measured approximately 1.1 μm in thickness and was surrounded by an electron dense cuticle (Fig. 38).

This apical zone is followed by a region about 100 μm long which contains numerous nuclei which are so closely packed together as to be almost touching each other. These nuclei are often joined together by extensions of the nuclear membrane, and many of them appear to be in a state of division (Fig. 38a). Scattered mitochondria are found interspersed between the nuclei together with membrane bound "pockets" of granular cytoplasm.

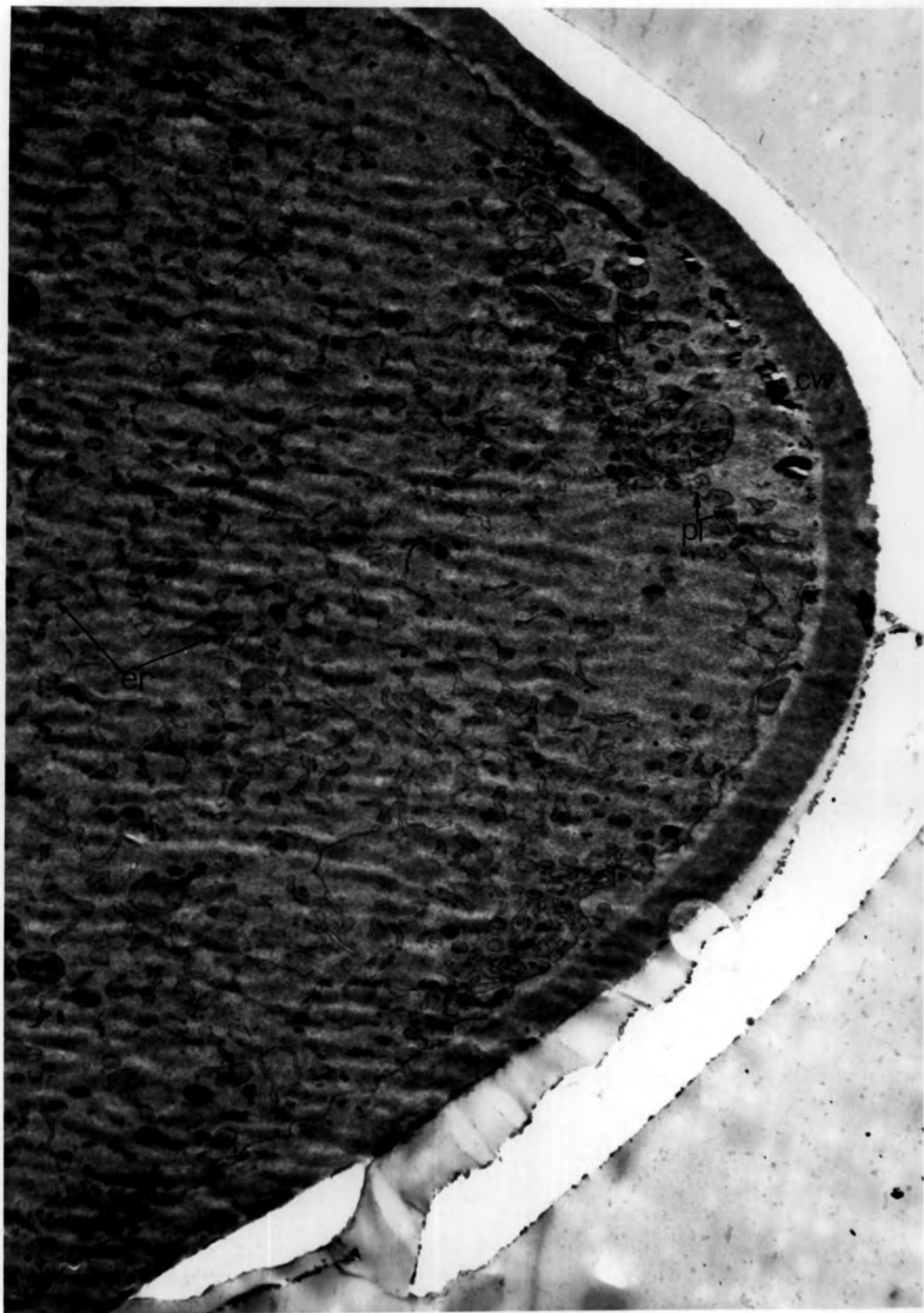
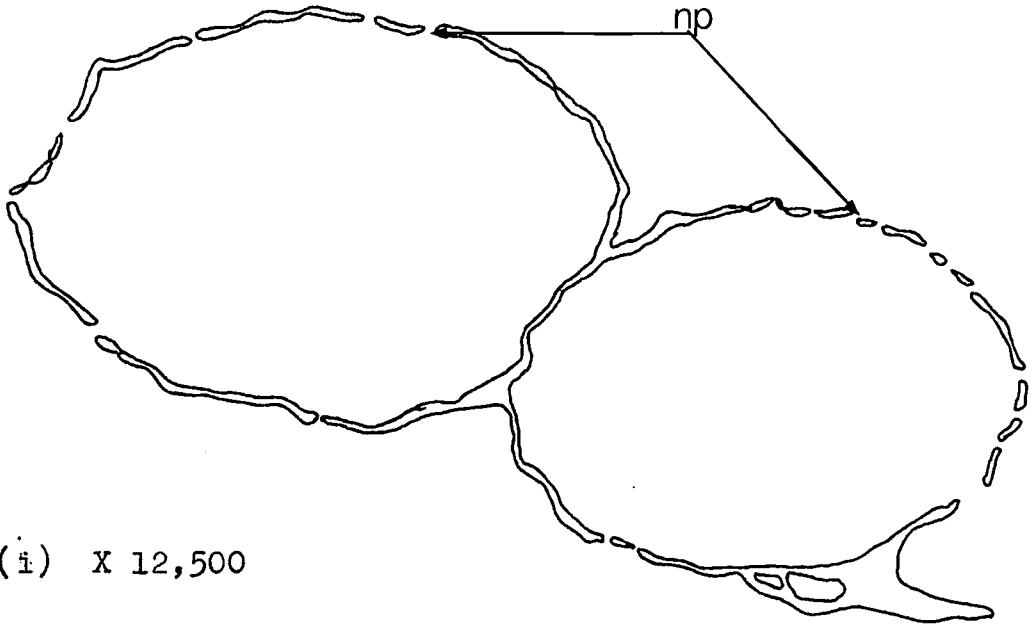
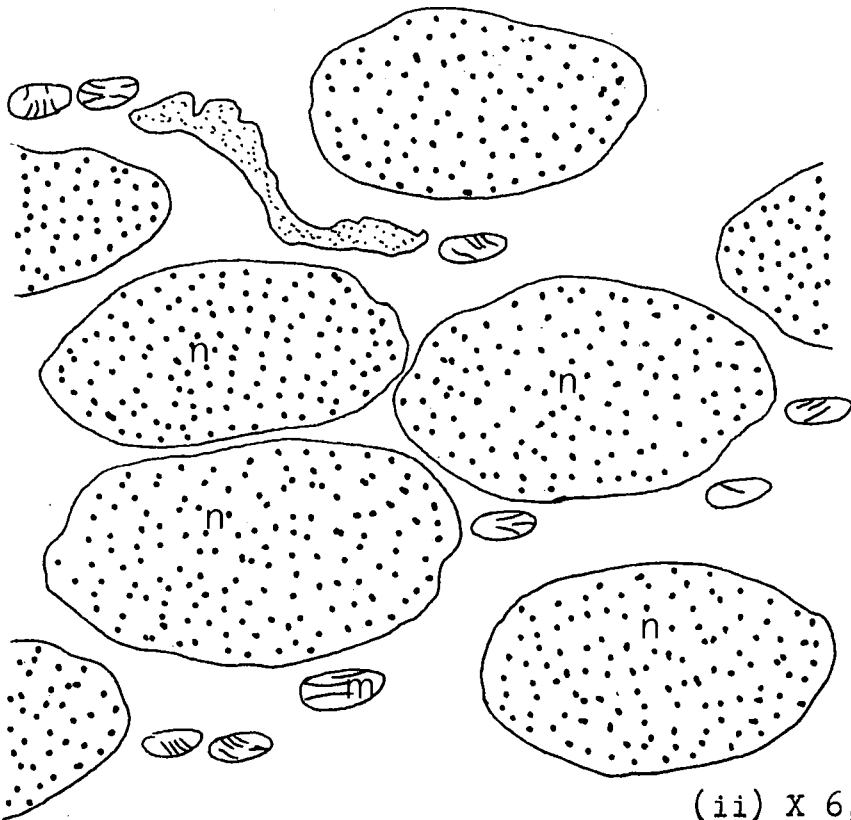

Fig. 38. Longitudinal section of a Stage I sporangiophore. tip. Note the extensive invagination of the plasmalemma and development of endoplasmic reticulum. X 87,250



(i) X 12,500



(ii) X 6,250

Drawings from electron micrographs to show,
 Fig. 38a (i) two nuclei with dividing membrane and
 (ii) close aggregation of nuclei, between 20 μ m
 and 100 μ m behind the apex of a Stage I
 sporangiophore

The cytoplasm surrounding this central core of nuclei and lying between it and the cell wall is almost devoid of nuclei, but contains numerous mitochondria, fat droplets and a concentration of glycogen granules. The plasmalemma in this region still possesses numerous invaginations surrounding vesicles between it and the cell wall.

About 100 μ m below the sporangiophore apex large vesicles, similar to those appearing during the cleavages of the Stage III sporangium and described later, are present. Further down the sporangiophore these enlarge and eventually coalesce to form the large central vacuole characteristic of the older parts of the sporangiophores.

Thornton (1968) attributes the formation of the central vacuole to the development of autophagic vesicles which he suggests originate by extension and pinching off of parts of the nuclear membranes. In support Thornton published micrographs showing vesicles containing mitochondria and other cell constituents in various stages of breakdown. I have not been able to obtain any corresponding micrographs with the exception of some of materials showing a considerable distortion of organelles indicating poor fixation. In all these instances the fixative was gluteraldehyde followed by osmium tetroxide, the fixative used by Thornton.

(ii) The Stage II apex.

Stage II begins with the enlargement of the apical zone. This continues until the terminal swelling is about three times the maximum diameter of the

sporangiophore and a bright yellow sporangium is formed. During this stage there is neither any elongation nor twisting of the sporangiophore.

The initial sporangium is bounded by a minutely sculptured sporangial wall which measures between 0.9 μm and 1.8 μm in thickness; it is thus very similar in dimension to that of the Stage I sporangiophore apex, a feature which suggests the intersusception of additional wall material between the existing wall constituents during the period of apical swelling. The sculpturing of the sporangium wall is a new feature not found in either the Stage I or later stages of sporangium development. There was no evidence with the techniques employed for the presence in this wall, or that of the Stage I sporangiophore, of a well defined microfibrillar structure such as is recognizable in the wall in other parts of the sporangiophore (Fig. 39). This does not however exclude the possibility of fibrillar material being present. The electron dense cuticle is still present.

The plasmalemma situated just within the wall showed numerous invaginations containing vesicles varying in size and number. These invaginations were similar to those described earlier and reported by several authors (Weisenach and Kessel 1965, Marchant, Peat and Banbury 1967, ~~Caro~~^{Caro}gne, Fielding and Byrde 1969 and Chet, Henis and Kisley 1969) as occurring in regions of wall synthesis in several fungi, and I see no reason to suppose anything other than their involvement in the maintenance of wall thickness during sporangial enlargement.

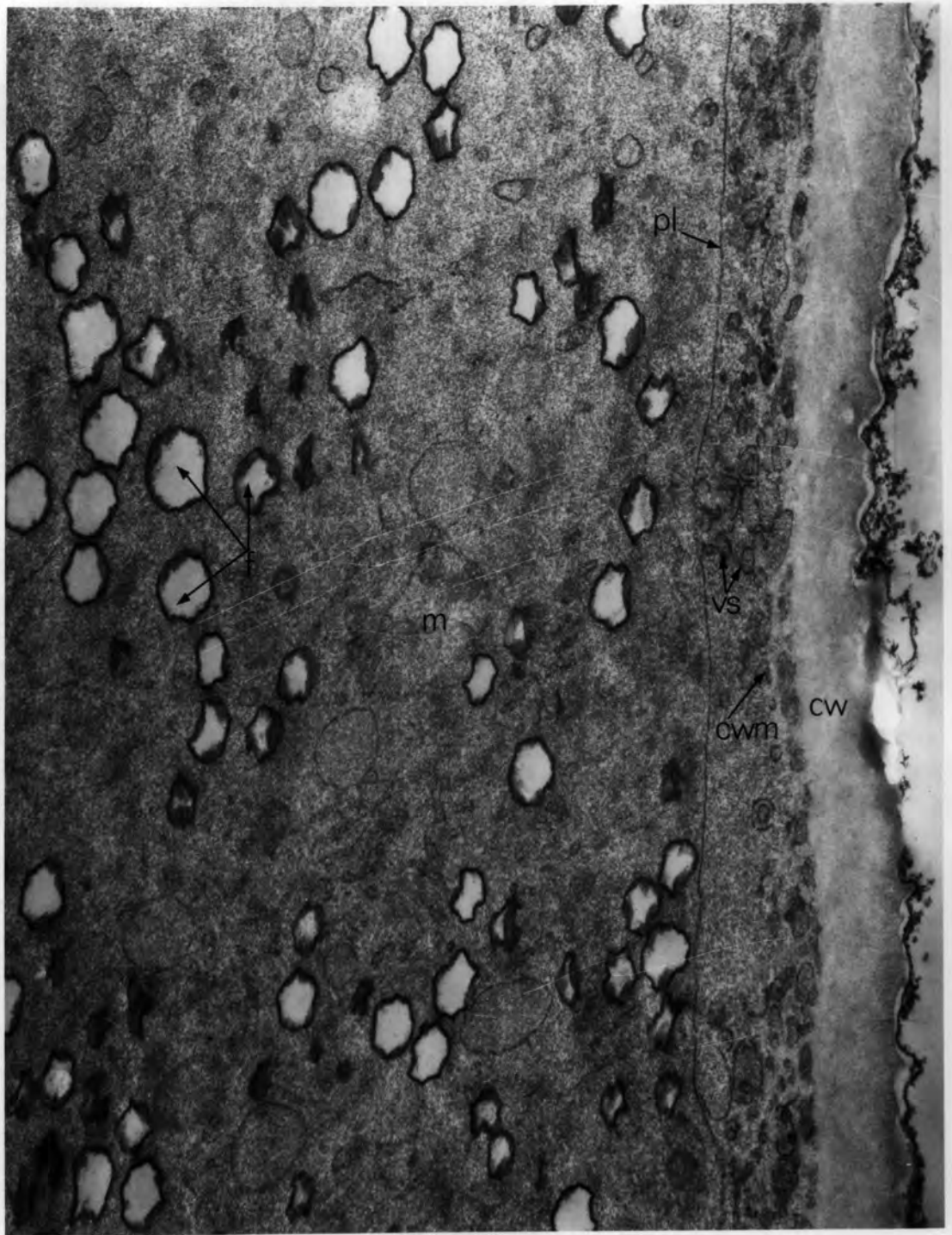

Fig.39. Part of the wall of a Stage II sporangium showing development of new wall material and the vesicles apparently associated with its deposition.

X 24,600

The cytoplasmic organelles of this initial sporangium when examined in longitudinal section exhibited a marked zonation forming three distinct areas (Fig. 39a).

Outer Zone.

Immediately within the spherical sporangial wall is a zone about 15 μm deep. The cytoplasm of this area is completely lacking nuclei but contains all the other organelles found within the Stage I sporangiophore. This zone itself was stratified into three layers. The outer and inner regions (A_1 and A_3 Fig. 40), of this zone each contained a well developed membrane system, numerous vesicles and ovoid bodies of low electron density internally but with an electron dense bounding layer. On the basis of their fixation these latter bodies are probably lipid globules consisting of a central core of saturated fats surrounded by unsaturated fats and phospholipids or alternatively the two forms of fat uniformly mixed with a reaction occurring at the surface.

The membranes forming the endoplasmic reticulum of the region appear to bud off vesicles at their extremities and in some instances the sections revealed chains of small vesicles comparable in length to the membranes themselves. In the A_3 region similar membranes were often grouped together to form structures showing some resemblance to the Golgi bodies of higher plants and the dictyosomes of Pythium debaryanum (Hawker and Abbott (1963)).

The vesicles.

In all the specimens examined the vesicles associated with the endoplasmic reticulum appear to be

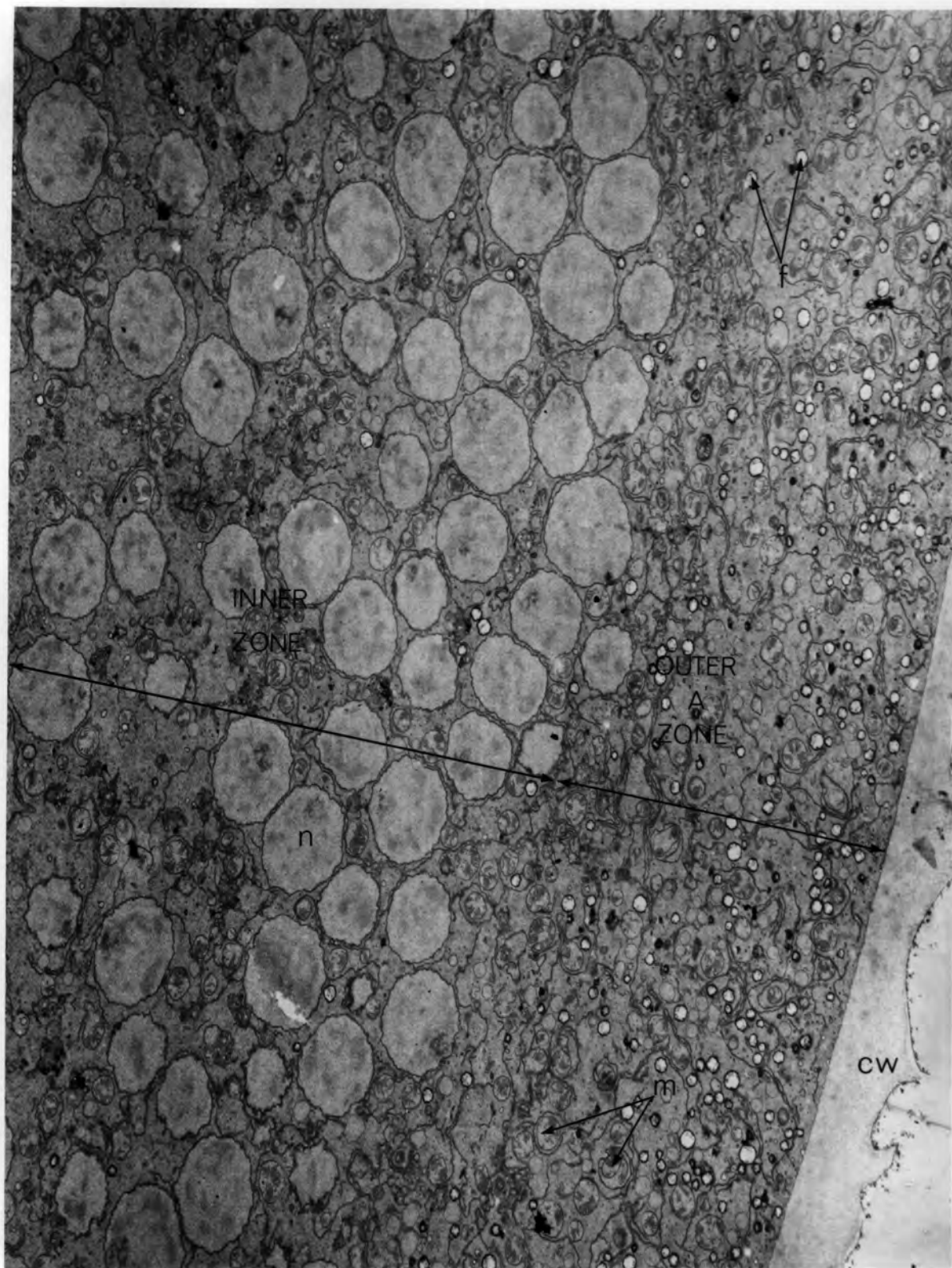

Fig. 39a. Section through the Stage II sporangium to show the organized distribution of organelles and the sculptured sporangium wall X 6400

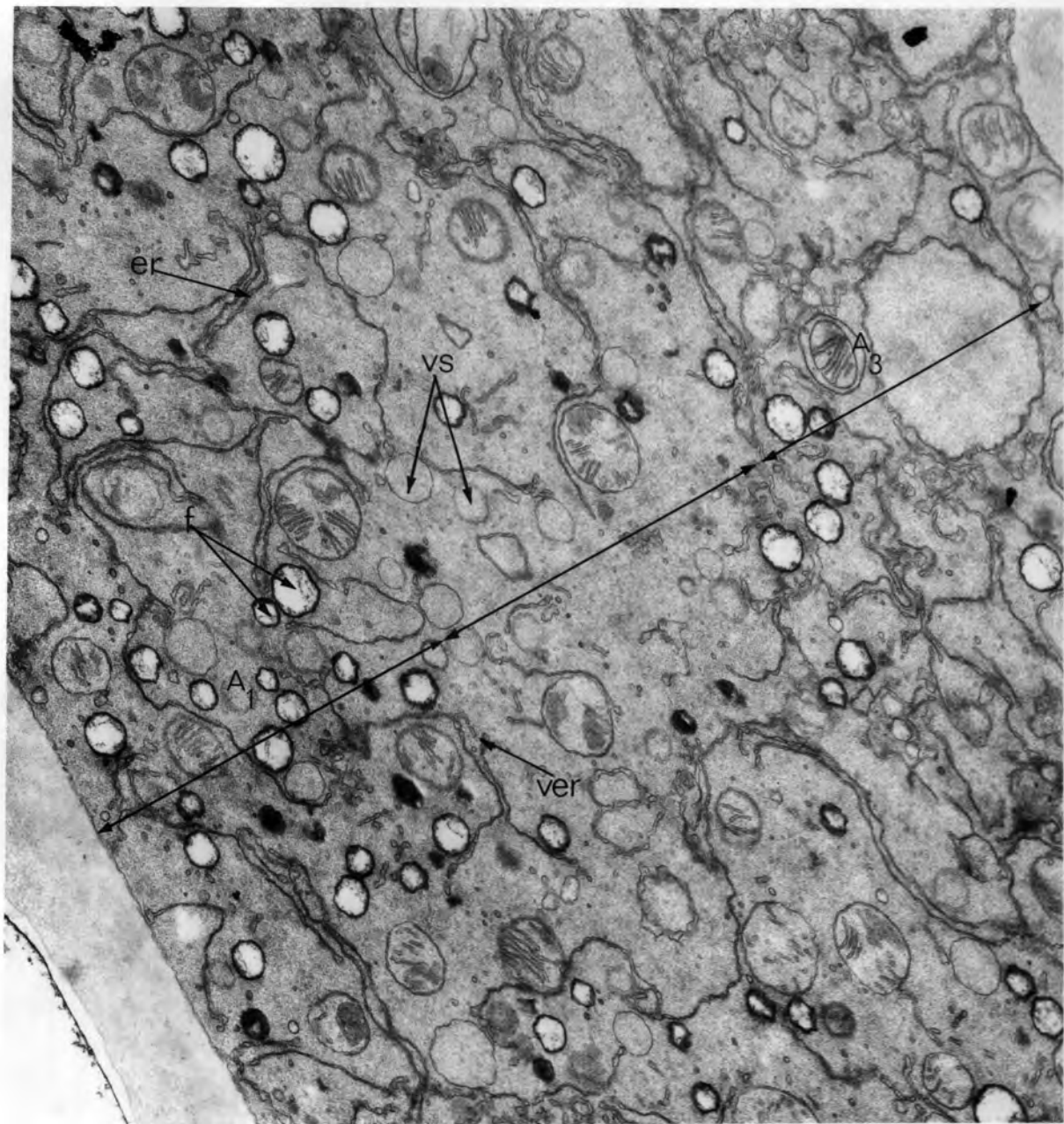

Fig. 40. The outer zone of the Stage II sporangium
X 15,900

of four types: microvesicles about 4-8 nm in diameter, spherical vesicles, pleomorphic vesicles and multivesicular bodies.

The microvesicles although common throughout this outer zone were particularly abundant just within the plasmalemma particularly in the older Stage II sporangia (Fig. 41.) In dimensions they were close to those vesicles found within the lomasome like bodies in various parts of the sporangiophores and developing sporangia. It is not improbable that these vesicles could be derived from the vesicular membranes, although one cannot totally exclude the possibility that they may represent either transverse or oblique sections of minute tubules, even though no clear evidence has been found for the existence of tubules of the appropriate dimensions within the developing sporangium. The spherical vesicles were the most conspicuous. They ranged in size from about 30 nm to 90 nm in diameter, the largest being about half the size of the largest mitochondria. These vesicles were bounded by a simple membrane and contained fine granular material very similar to the ground plasm.

The pleomorphic vesicles and multivesicular bodies were rarely found in the outer A_1 region but were numerous in the inner A_3 region. The pleomorphic vesicles appeared to be formed from swellings in isolated strands of the endoplasmic reticulum. They contained a small number of electron dense granules about 13 nm in diameter which sometimes appeared clumped together. The multivesicular bodies were less frequent than any of the other three kinds of vesicles. In form and dimension they were usually similar to the mitochondria.

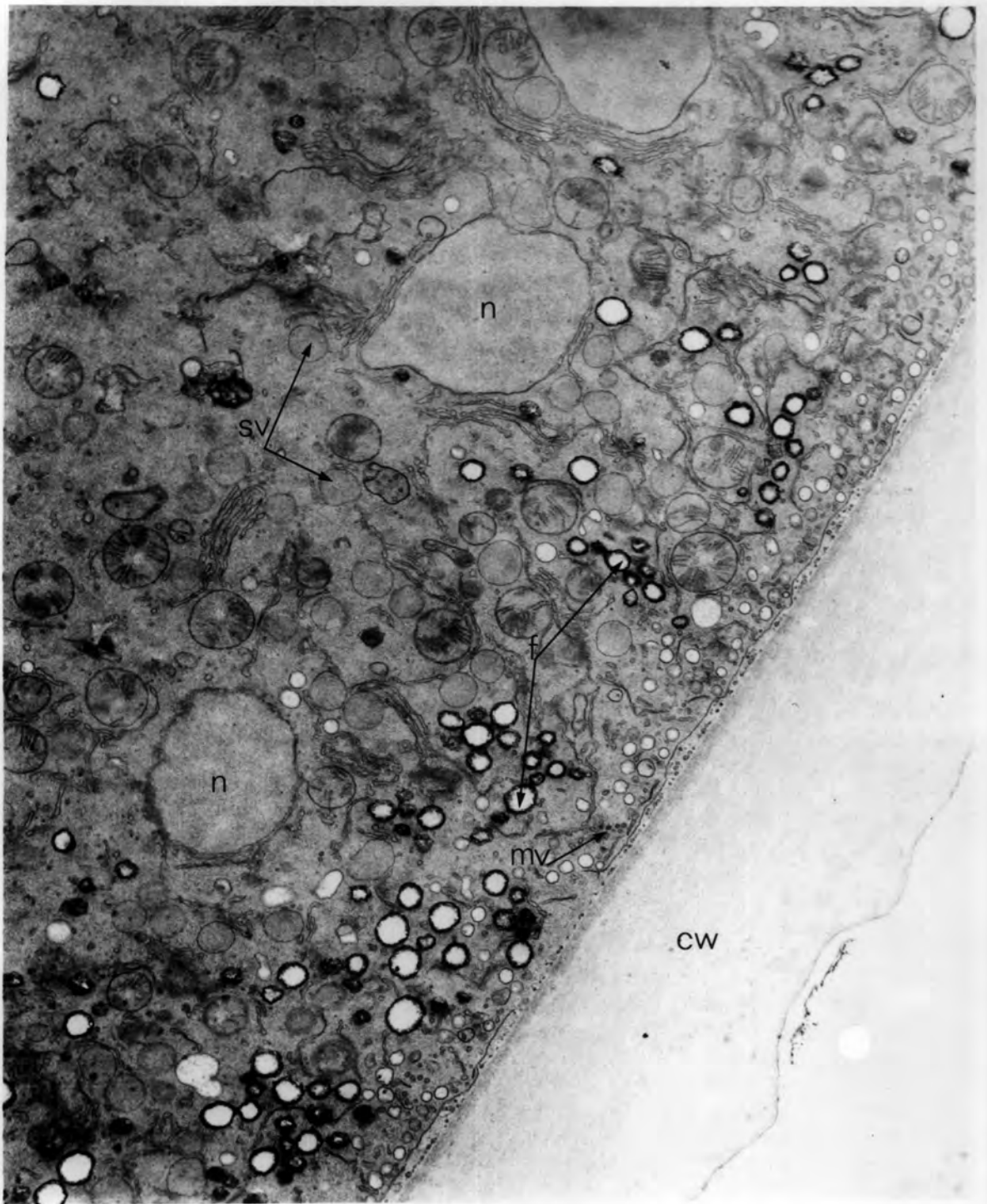

Fig. 41. Late Stage II sporangium showing numerous microvesicles just within the plasmalemma X 18,300

Each contained many small hollow vesicles. Some of them appeared, like the pleomorphic vesicles, to be formed by the distension of the isolated strands of endoplasmic reticulum. Cisternæ (Fig.42.) (Bracker 1967) of varying configurations and size were also found in this zone although they were not of frequent occurrence.

Inner Zone.

Situated within this outer zone is a crescent shaped zone approximately 8 µm-11 µm thick. It was formed by a close aggregation of nuclei (Fig.42.). The nuclei were about 2-7 µm in length and most possessed an electron dense body, lying asymmetrically, which was probably the nucleolus. Other irregular dense areas probably indicated the position of chromocentres. Each nucleus was bounded by a well defined nuclear envelope with many simple nuclear pores. Almost every nucleus was surrounded by at least one incomplete sheet of endoplasmic reticulum which often had interconnections with the nuclear envelopes. Often several nuclei were connected by means of these sheets of endoplasmic reticulum. The small areas remaining between the nuclei were occupied by either mitochondria or spherical vesicles or more frequently by a pleomorphic vesicle and occasionally a multi-vesicular body or cisterna (Fig.43.)

Central Zone.

The characteristic feature of the central zone was the membrane system. For the most part this appeared in the sections as stacks of membranes with vesicular swellings at their edges, and adjacent, presumably budded off, free vesicles. These stacks were not unlike

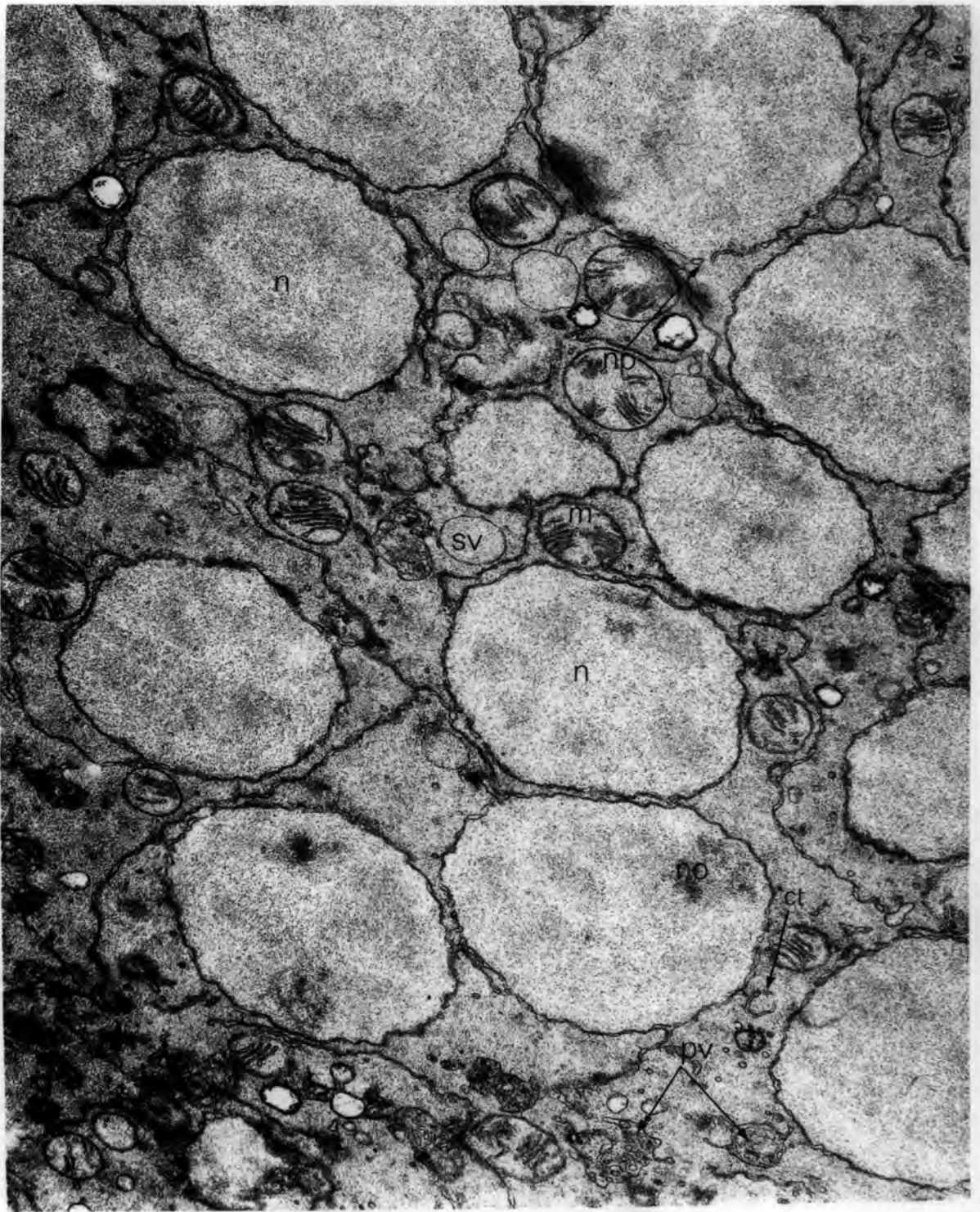

Fig. 42. Part of inner zone of the Stage II sporangium formed of closely aggregated nuclei. X 18,300

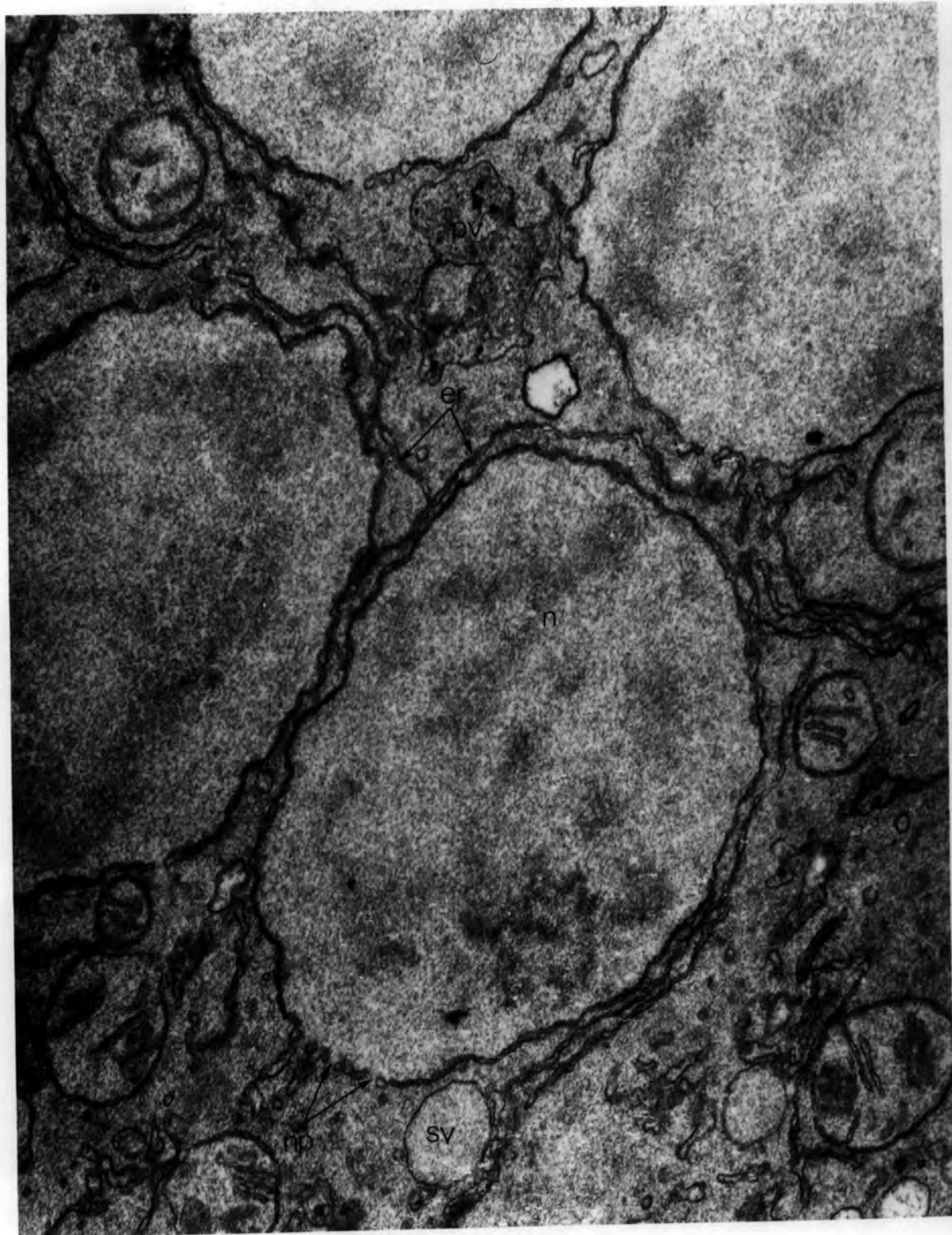

Fig. 43. Nuclei and associated endoplasmic reticulum
of the Stage II sporangium. X 36,600

the membrane stacks of the outer zone, although each group did contain many more membranes. Between the stacks lay isolated strands of endoplasmic reticulum, mitochondria and electron dense granules which were about 8 nm in diameter. Numerous large pleomorphic vesicles and microvesicles also occurred in this region. (Fig.44).

Situated at the boundary of the nuclear and central zones and laying about 3-5 μm apart were several groups of closely packed irregular shaped vesicles with thick electron dense bounding membranes. I have never found similar aggregations of vesicles anywhere else in Phycomyces. There was little evidence of glycogen granules in any of the three zones. Indeed, I have found little evidence of the presence of glycogen in the Stage I apex, although its presence has been reported by others (Thornton 1968); glycogen is however present in the older parts of the Stage I sporangiophore between the nucleated region and the vacuole.

VIIIId.(iii) Stage III sporangium.

This is the period during sporangium development when there is neither an increase in volume of the sporangium nor any elongation of the sporangiophore. It is a period of spore development within the fully extended sporangium, its termination is indicated by resumed activity in the growth zone of the sporangiophore and its subsequent elongation. During this phase the sporangium contents undergo division to produce the spore initials. At the completion of this phase, the sporangium contains numerous multinucleate spores.

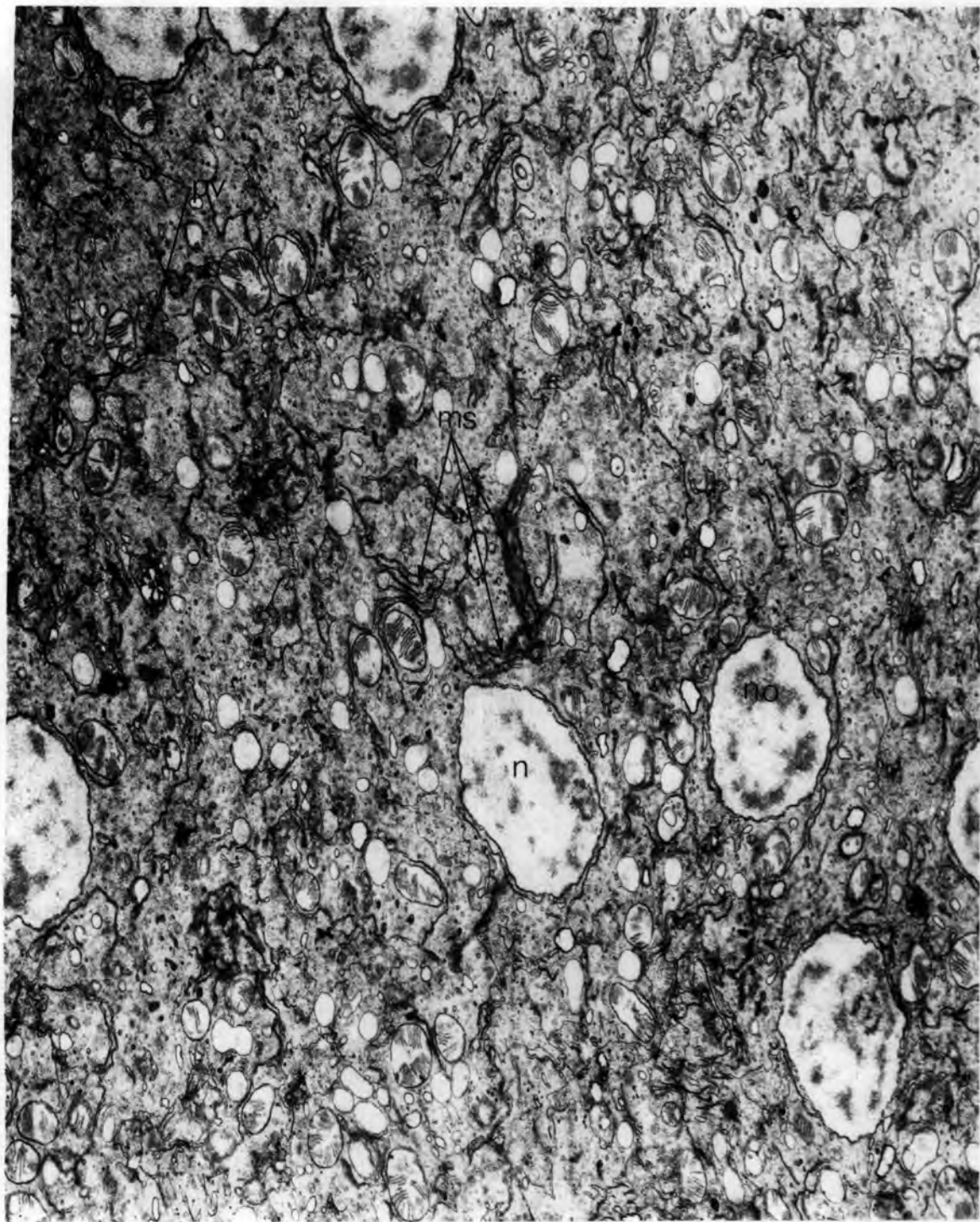

Fig. 44. Central zone of the Stage II sporangium.
Note the extensive development of the membrane
system. X 12,200

At the onset of cleavage, numerous small vesicles containing coarse granules become apparent (Fig.45); the origin of these vesicles is uncertain but since the pleomorphic vesicles and multivesicular bodies disappear at about this time, it seems not unlikely that the granular vesicles originate from one or other, or both, of these organelles.

On the micrographs closely associated with these cleavage vesicles an extensive development of folded endoplasmic reticulum can be seen. From this, straight membranes extend out into the surrounding ground plasma and sometimes serve to join together two or more cleavage vesicles. Some of the vesicles are, at the same time, joined to one or more nuclei by membranes which appear as extensive evaginations of the outer nuclear membrane (Fig.46).

By fusion of these initial cleavage vesicles a conspicuous system of large irregular shaped cleavage vesicles is produced. As they develop these enlarged vesicles continue to possess a coarse granular matrix containing many rod like bodies. They do however eventually lose their irregular form and the associated endoplasmic reticulum disappears, presumably by its incorporation into the bounding membranes of the vesicles.

During the phase of cleavage vesicle development, when the latter are extremely irregular in form, there appears to be present within the cytoplasm a second type of vesicle. These often appear to have a quite smooth bounding membrane, to be more or less elliptical in section, and to contain elliptical bodies enclosing:

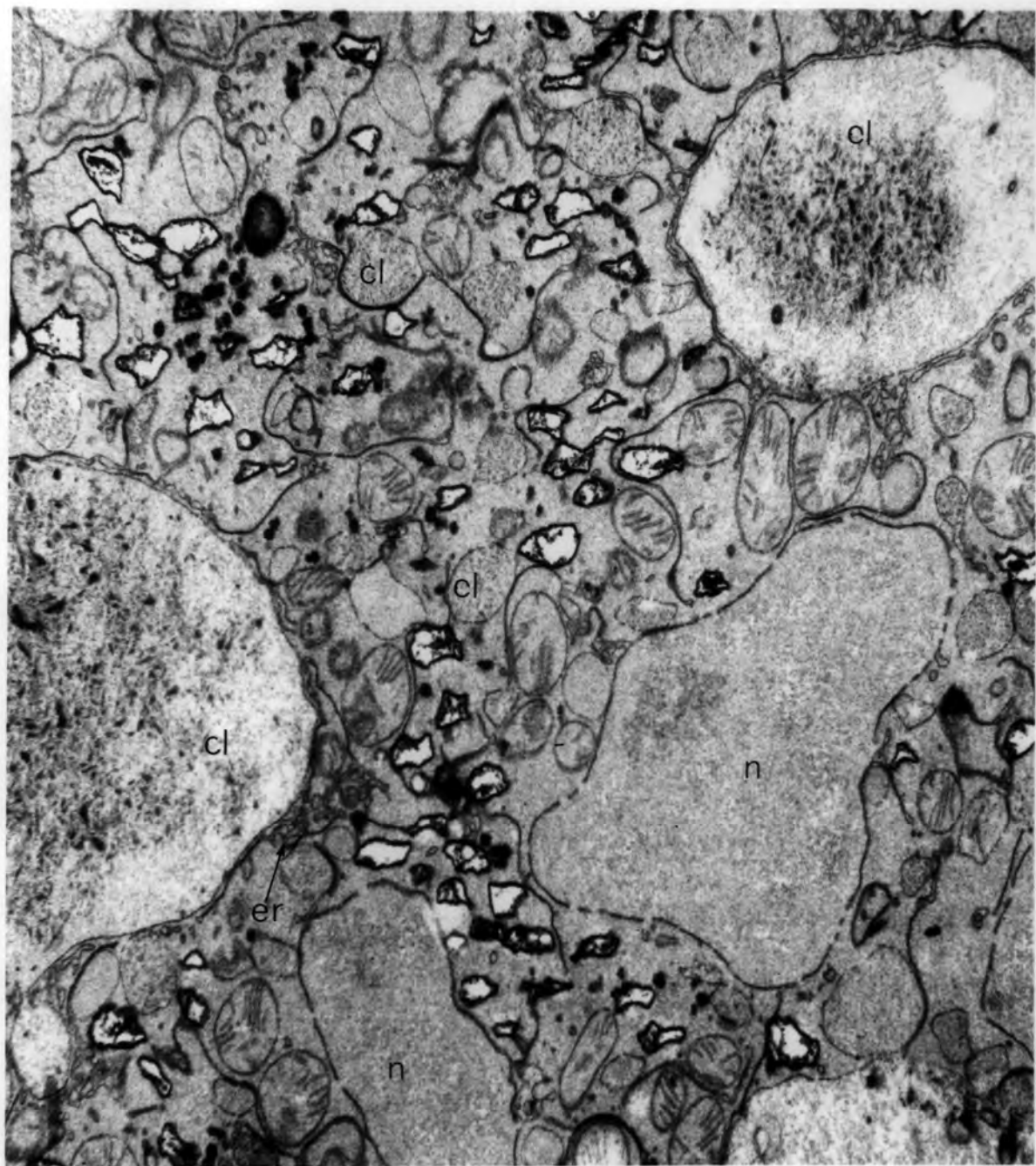

Fig. 45. The Stage III sporangium showing many small cleavage vesicles and two large cleavage vesicles. Note the presence of folded endoplasmic reticulum round the cleavage vesicles. X 16,900

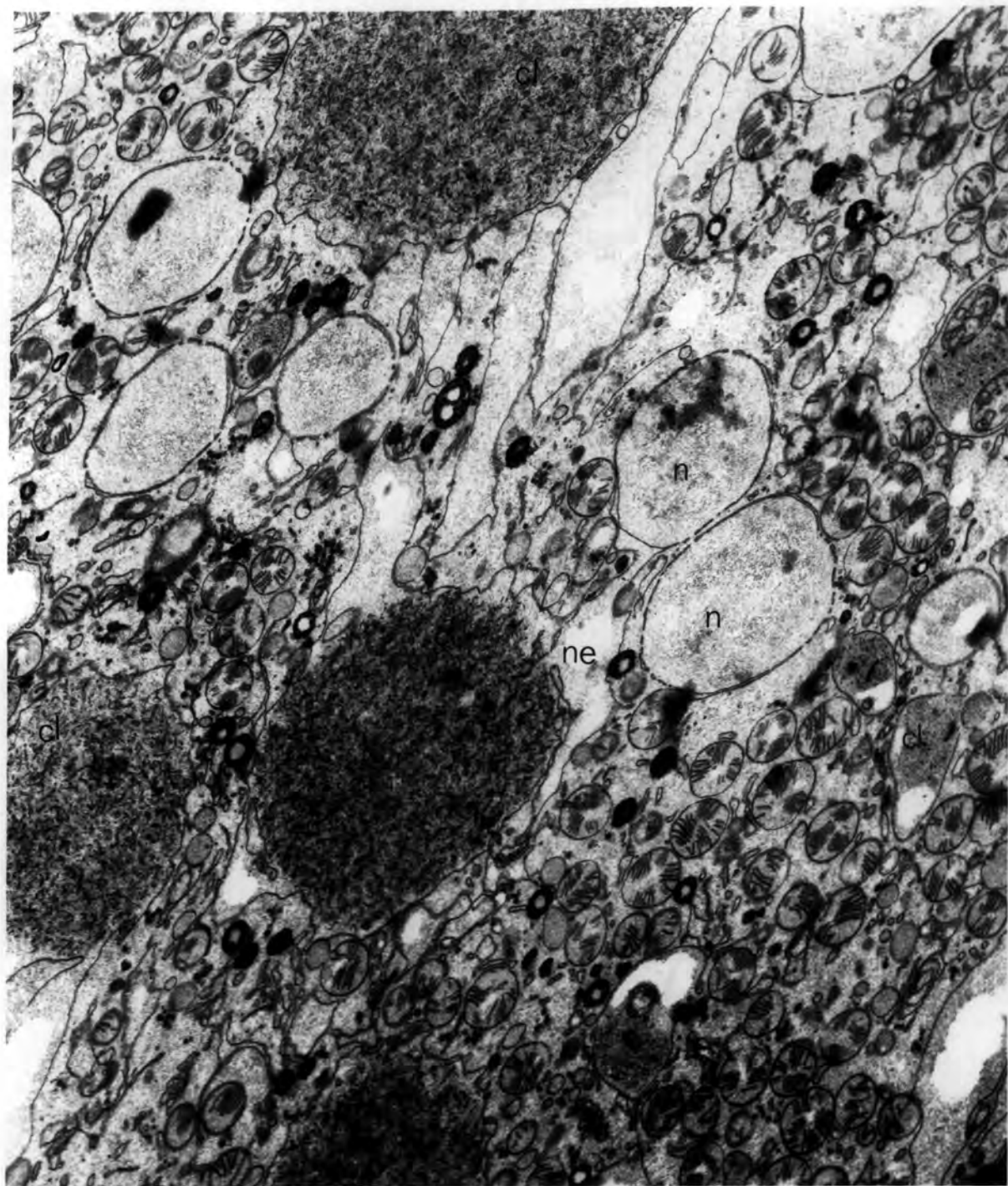

Fig. 46. Part of a Stage III sporangium showing the developing cleavage vesicles. The membrane of one vesicle is continuous with a nuclear membrane. X 11,875

various membrane configurations (Fig.47). These bodies were at first difficult to interpret, but examination of several sporangia in the initial stage and later stages of cleavage revealed no organelle from which they could have been derived, nor to which they could give rise. Re-examination of the micrographs containing both the irregular cleavage vesicles and the elliptical bodies leads me to suggest that the latter are not discrete organelles of the developing sporangial mass, but sections across the cleavage vesicles incorporating areas of groundplasm almost completely surrounded by two or more of the elongated fingerlike extensions of the cleavage vesicles (Fig.48).

During the development of the cleavage vesicles, fat droplets are the most conspicuous storage material, with small isolated areas of glycogen granules.

The interassociation of the cleavage vesicles, endoplasmic reticulum and nuclei is in some ways similar to the situation that exists in Gilbertella persicaria (Bracker 1966) and, as in the latter fungus, probably determines the directional growth of the cleavage vesicles and hence the boundaries of the initial spores. This predetermination of the cleavage planes will ensure that the resulting spore initials will each contain at least one nucleus.

As the cleavage vesicles enlarge (Fig.49) they eventually coalesce with each other and reach the plasma-membranes of the sporangium, with which the vesicle membrane coalesces (Fig.50), thus forming a membrane-bound network throughout the sporangium. The innermost cytoplasm of the sporangium during cleavage is isolated from the outer spore-forming cytoplasm by a crescent shaped series of vesicles (Fig. 51).

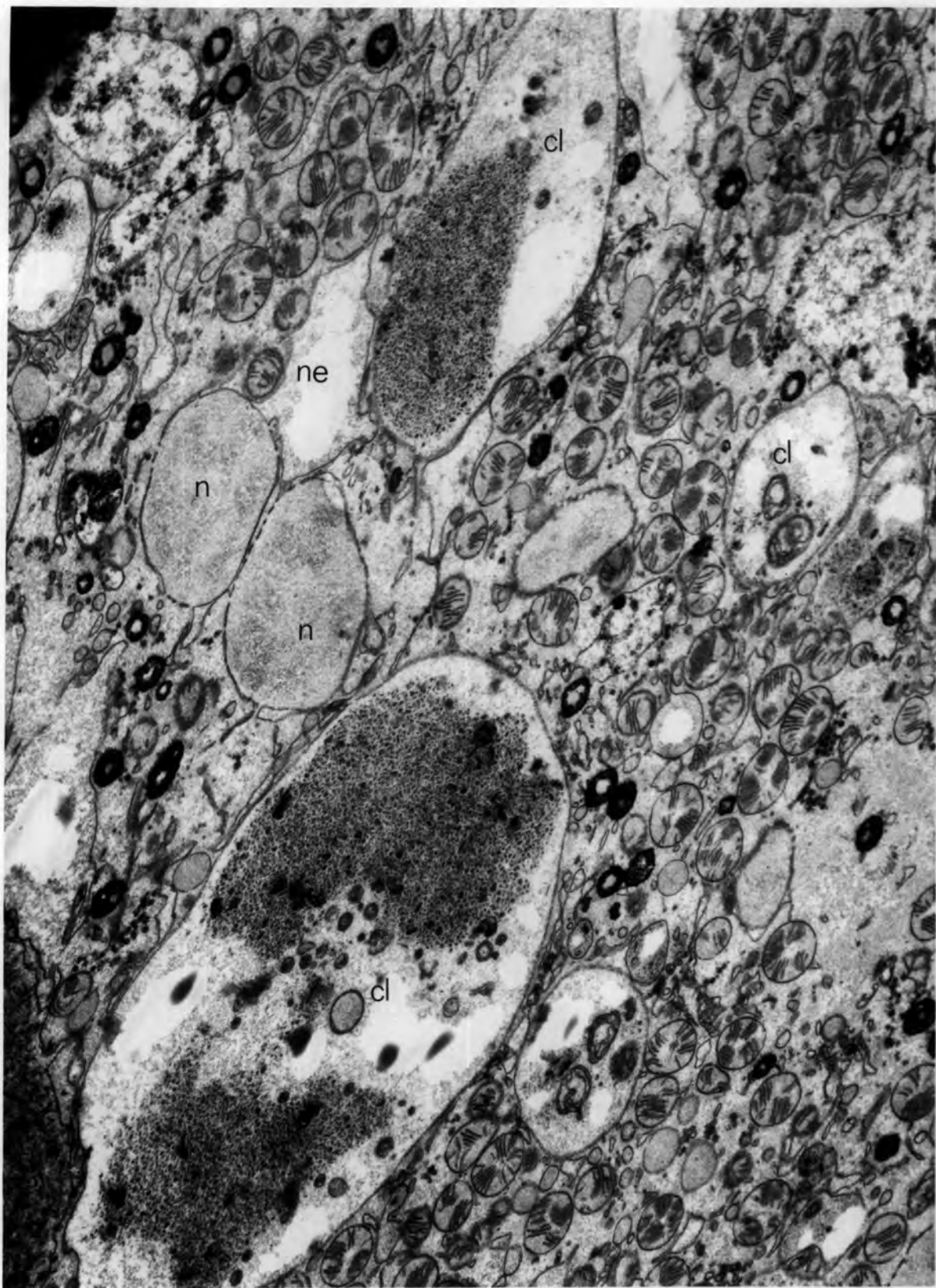

Fig. 47. Part of Stage III sporangium showing what appeared to be a second type of cleavage vesicles. X 12,800

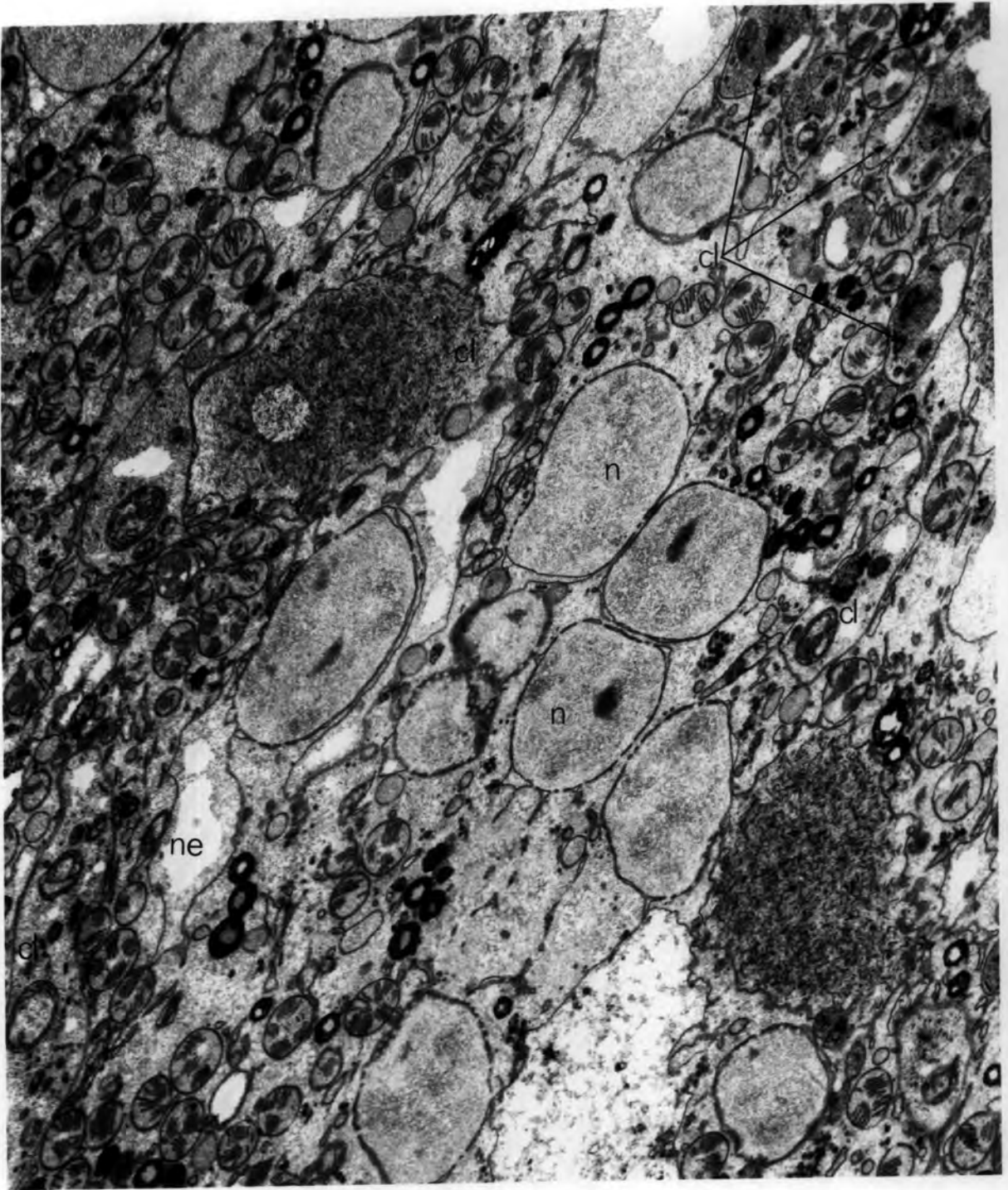

Fig.48. Part of Stage III sporangium showing two types of vesicles. X 11,875

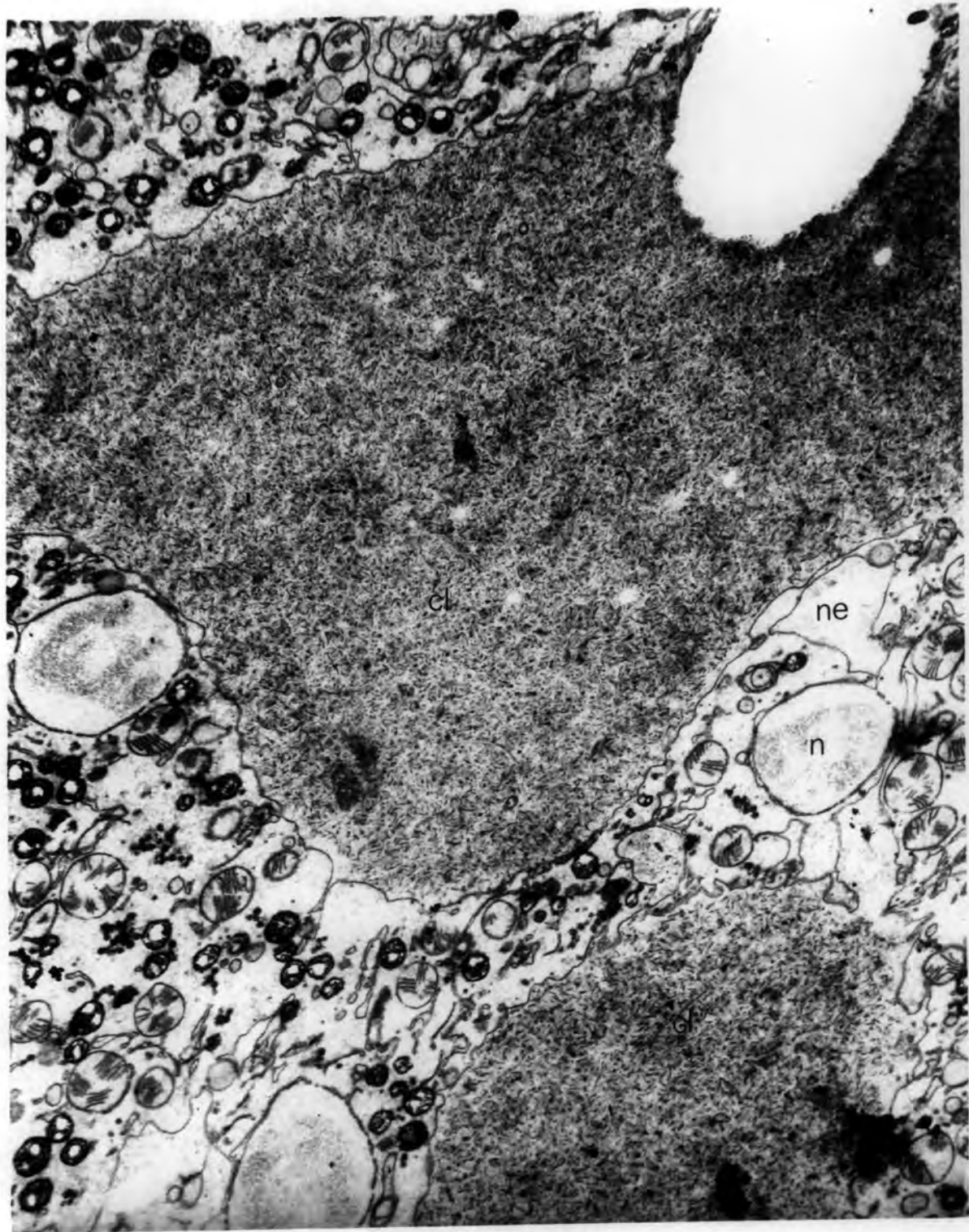

Fig.49. Two large cleavage vesicles. Note the evagination from the nucleus lying between the vesicles. X.11,875

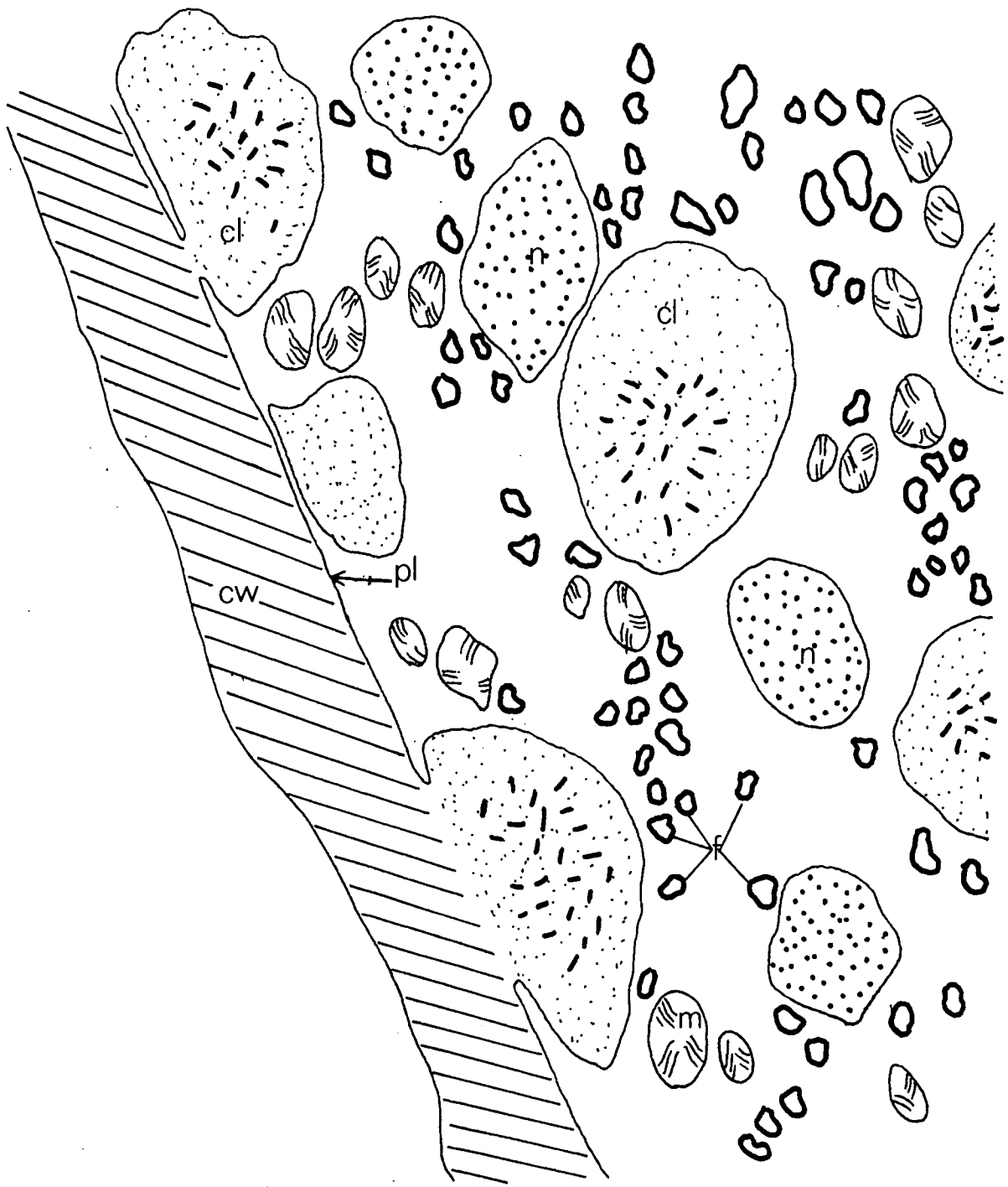

Fig.50. Drawing from an electron micrograph showing the fusion of two cleavage vesicles with the plasma-membrane of the sporangium. X 12,500



Fig.51. Drawing from an electron micrograph showing the fusion of the cleavage vesicles which isolate the columella from the sporangium contents. Note the accumulation of Glycogen in the columella.

X 12,500

These on coalescence form a dome shaped septum which fuses with the sporangium plasma membrane at the base of the sporangial swelling. The columella is thus formed.

VIIIId. (iv) Possible Mechanism of Cleavage Vesicle Enlargement.

The evidence from the electron micrographs would support Swingle's view that the cleavage vesicles are present at the onset of sporangium development. His view that the contraction of the sporeplasm is responsible for the enlargement of the cleavage vesicles must of necessity be at least partially correct since cleavage, brought about by the enlargement of the vesicles, is not accompanied by an increase in the total volume of the sporangium.

Examination of the micrographs of the sporangium during cleavage shows clearly a pronounced compacting of such organelles as nuclei and mitochondria (Fig.52) in the areas destined to be spores as the cleavage vesicles develop. There is not however any marked increase in the electron density of the ground plasm which might perhaps be expected if the sporeplasm was contracting.

The precise mechanism by which the sporeplasm contracts and the cleavage vesicles enlarge is difficult to envisage. The one which most readily presents itself is the osmotic withdrawal of water from the sporeplasm into the cleavage vesicle. For this to take place however, there must develop at the onset of cleavage a high osmotic potential within the cleavage vesicle with respect to the ground plasm. The osmotic difference between the cleavage vesicle content and the ground plasm must then be maintained until at least the time of completion of the process.

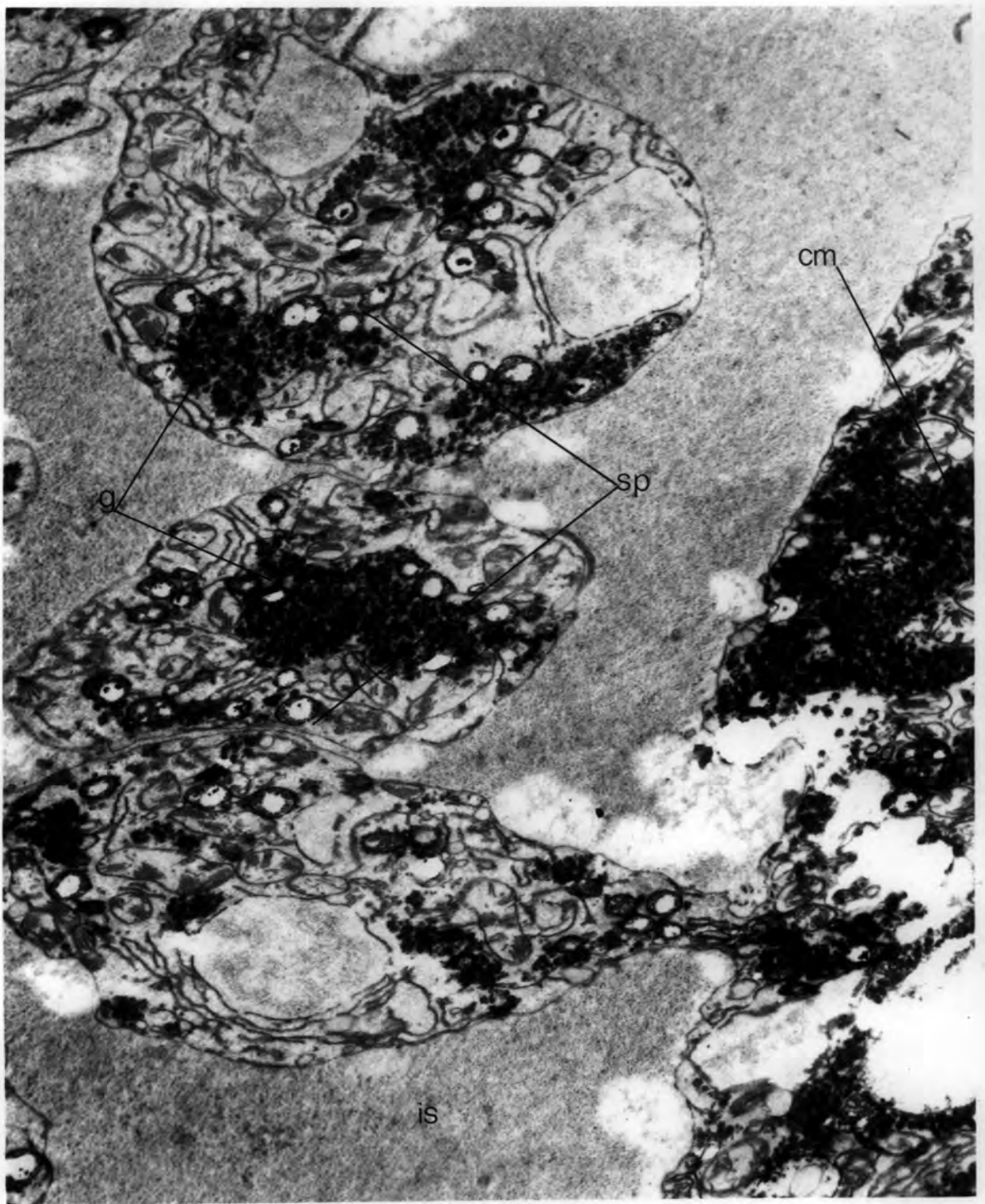

Fig.52. Part of columella and three newly formed spores from a late Stage III sporangium. Note the close aggregation of organelles and the appearance of glycogen. X 11,250

The development of such an osmotic difference between the two would imply a rather specialized activity on the part of the cleavage vesicle membrane.

VIIIId. (v) Sporangium Membranes.

The fusion between the sporangium plasma membrane and the cleavage membranes suggest that the two may possess a structural similarity which differs from the membrane structure of other organelles within the sporangium. Nevertheless, as suggested by Bracker (1967), this structural similarity cannot be the only factor governing the fusion of the membranes; if it were so, then one might expect to observe frequent and gross fusion between the organelles. It may be significant that fusion between the plasma membrane and the cleavage membranes has only been observed at late cleavage, suggesting the possible role of a time factor in triggering off a transient change in the membranes concerned, resulting in a temporary period of compatibility between them.

The whole sequence of events during cleavage strongly suggests the existence of not one critical stage as postulated by Bracker (1967) but a series of such stages resulting in several transient changes which culminate in cleavage.

VIIIId. (vi) The Newly Formed Spore.

When first formed the cytoplasm immediately within the columella membrane and the spores lying nearest to the columella are rich in glycogen. This appears as large dense aggregations of granules about 0.12 μm in diameter (Fig.52)

Each multi-nucleate spore contains several fat droplets, mitochondria and fragments of endoplasmic reticulum, and is bounded by an apparently incomplete membrane.

The interspore material remains coarsely granular, most of the granular material appearing as electron dense rod like bodies about 0.08 μm in length (Fig.53)

VIIId. (vii) Spore Maturation.

At the onset of maturation, the spore membrane loses its irregular form and become much smoother so that the spores appear spherical or elliptical in section. This change in shape could be attributed to an increase in turgor as the metabolically active spores absorb moisture from the interspore material, or to the interaction of an increased turgor and the laying down of an electron dense wall layer about 25 nm thick. In spores that are still irregular in form, pockets of small vesicles each about 45 nm in diameter have been observed in what might be considered as invaginations in the spore membrane (Fig.54). When first recognisable these vesicles appeared to arise in the interspore material that was originally the contents of the cleavage vesicles. I should like to suggest that these vesicles play some part in the deposition of the primary wall material which develops around the spores and is about 25 nm thick.

Spore Lomasomes.

Lomasome-like bodies were commonly observed in spores that had developed the primary wall layer (Fig.55) They appeared as groups of small vesicles lying between the invaginated membrane and the primary wall layer. Many spores contained up to seven or eight such bodies in one section. These lomasome-like bodies when seen in cross sections were either dome shaped (about 200 nm from apex to base x 480 nm along the base) or tubular (about 240 nm from apex to base x 140 nm along the base) in appearance. Similar bodies were rarely found in older

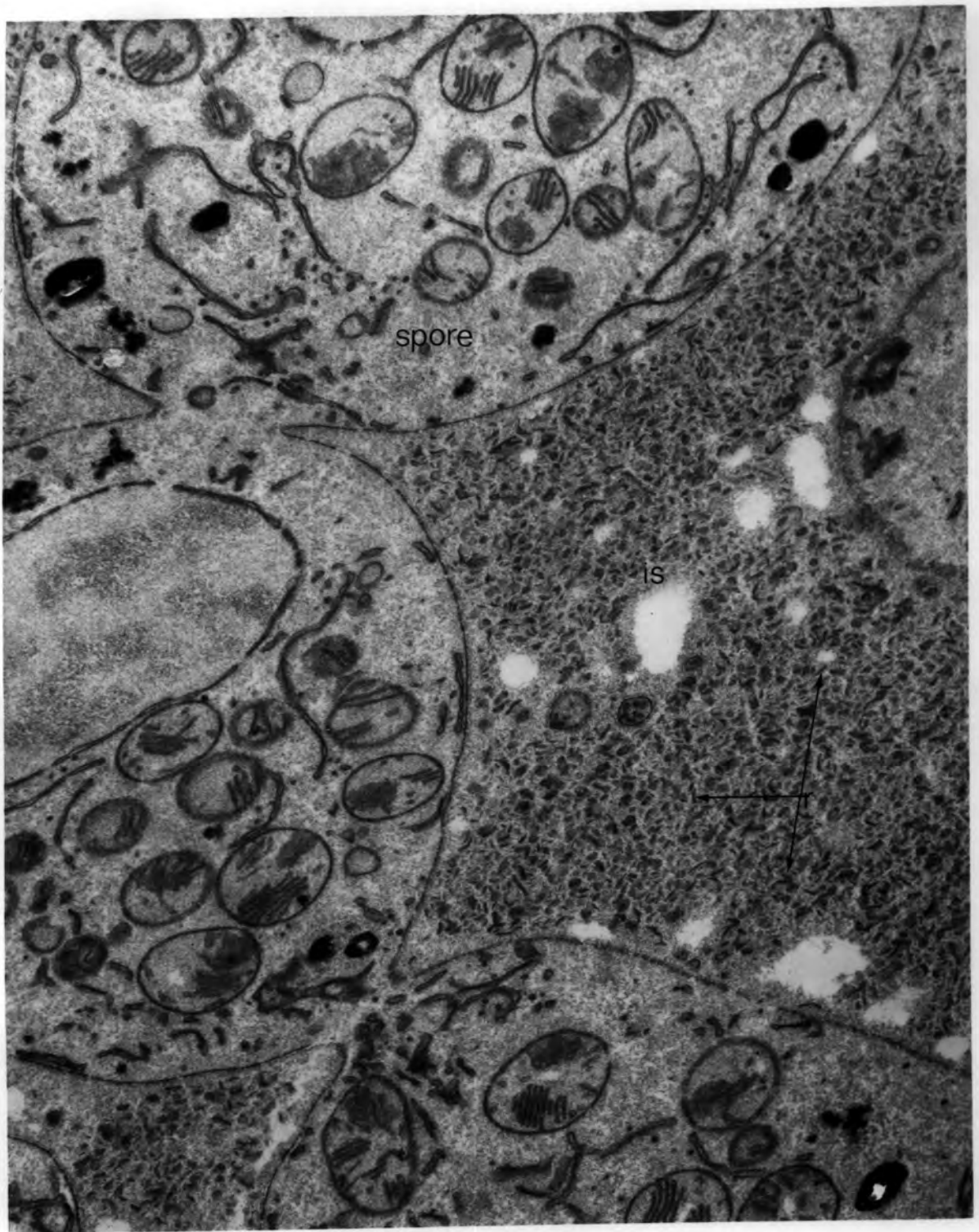

Fig.53. Parts of four newly formed spores surrounded by the interspore plasm, originally the contents of the cleavage vesicles, containing numerous rod shaped bodies.

X 18,750

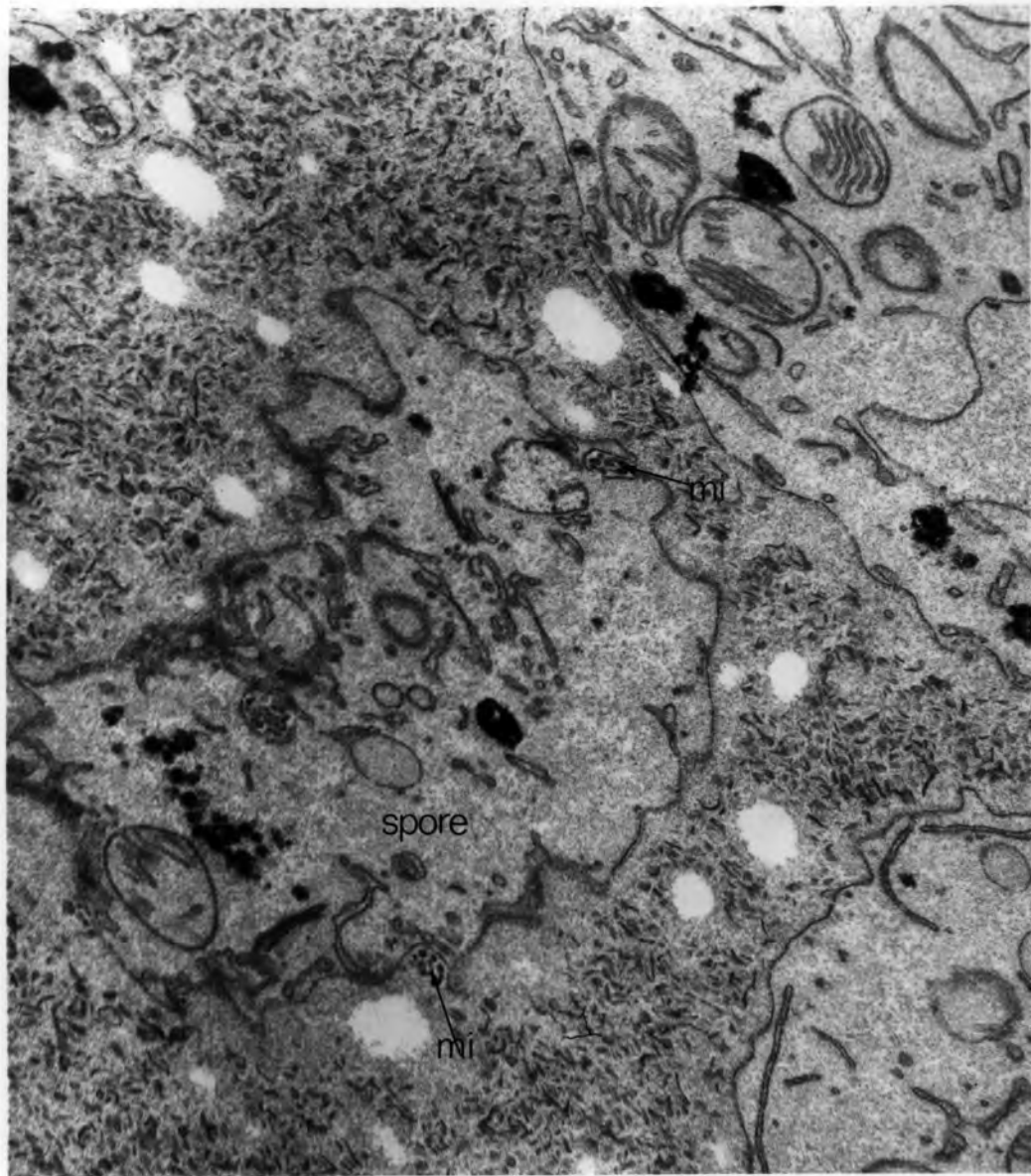

Fig.54. Newly formed spores showing invaginations of the spore membrane to form pockets containing vesicles. X 28,750

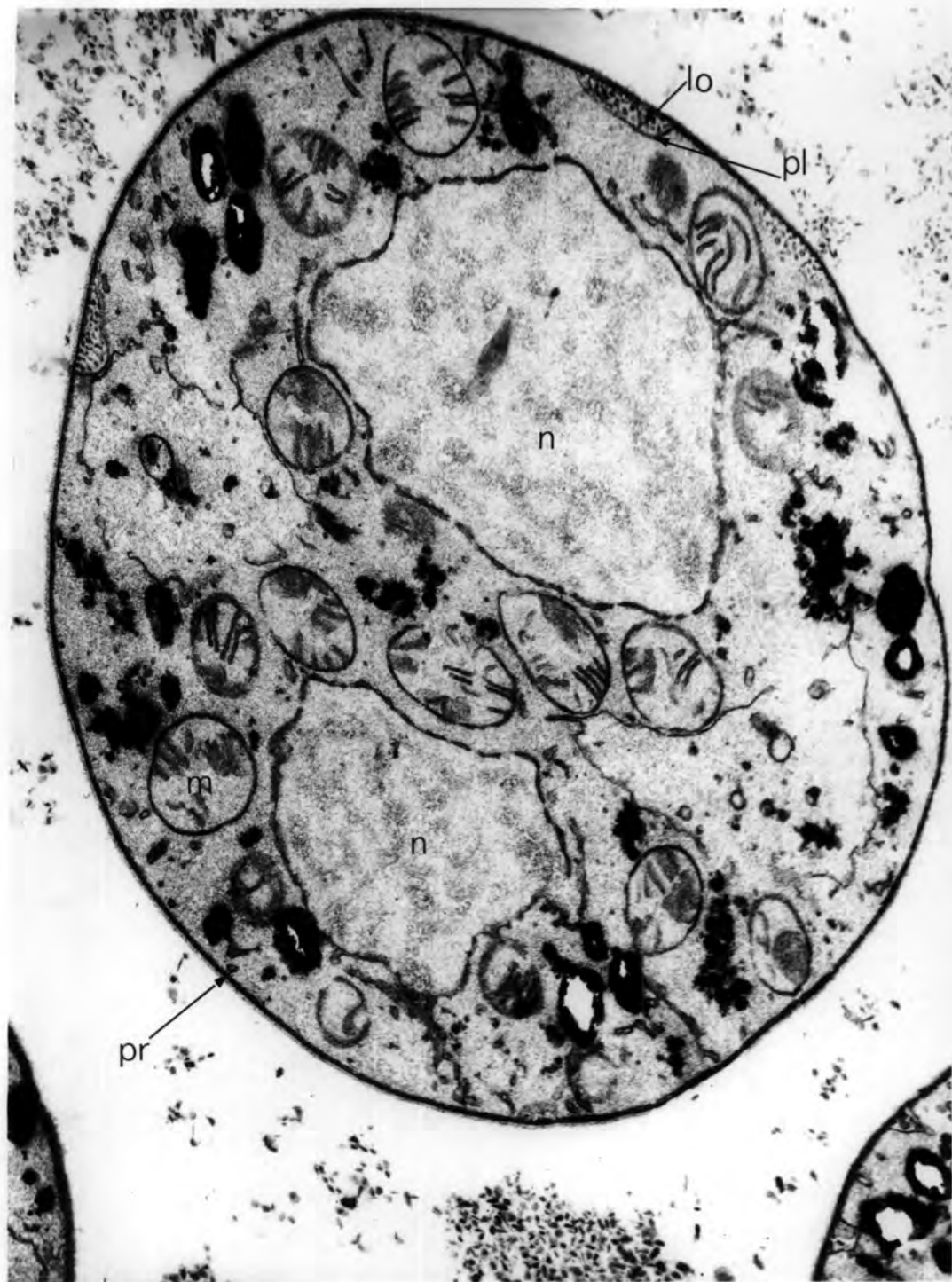

Fig.55. Spore with electron dense primary wall layer and lomasome-like body lying between the plasma-membrane and the wall layer. X 17,800

spores which had started to lay down secondary wall material.

Reticulate tubular wall systems.

As the spores continued their maturation, the lomasome-like bodies disappeared. Their place was then taken by a series of wall tubules of various configurations (Fig.56). Most appeared as extensive ingrowths of the plasmalemma, forming reticulate systems of various forms and dimensions. Some were globose while others were flattened with their long axis extending parallel to the spore wall. Several similar membrane-bound tubules, some resembling the multivesicular bodies reported by Marchant et al (1967), were found free within the cytoplasm of the spores. From examination of serial sections, it was found that these bodies were actually part of the extensive reticulate wall systems and were in fact linked at some point to the plasmalemma. These latter systems were more numerous in spores which had produced secondary walls, or at least contained some secondary wall material.

Storage Material.

The spore initials are generally rich in glycogen as are the spores at the primary wall stage of development. With the appearance of the reticulate tubular wall systems and the development of secondary wall material, the glycogen store within the spore diminishes and often disappears altogether. At the same time, large irregular-shaped vacuoles appear within the cytoplasm (Fig.56). In many instances the tubular systems are associated with those vacuoles at one or more points.

The large fat droplets are the only storage materials evident within the spores when they are fully matured.

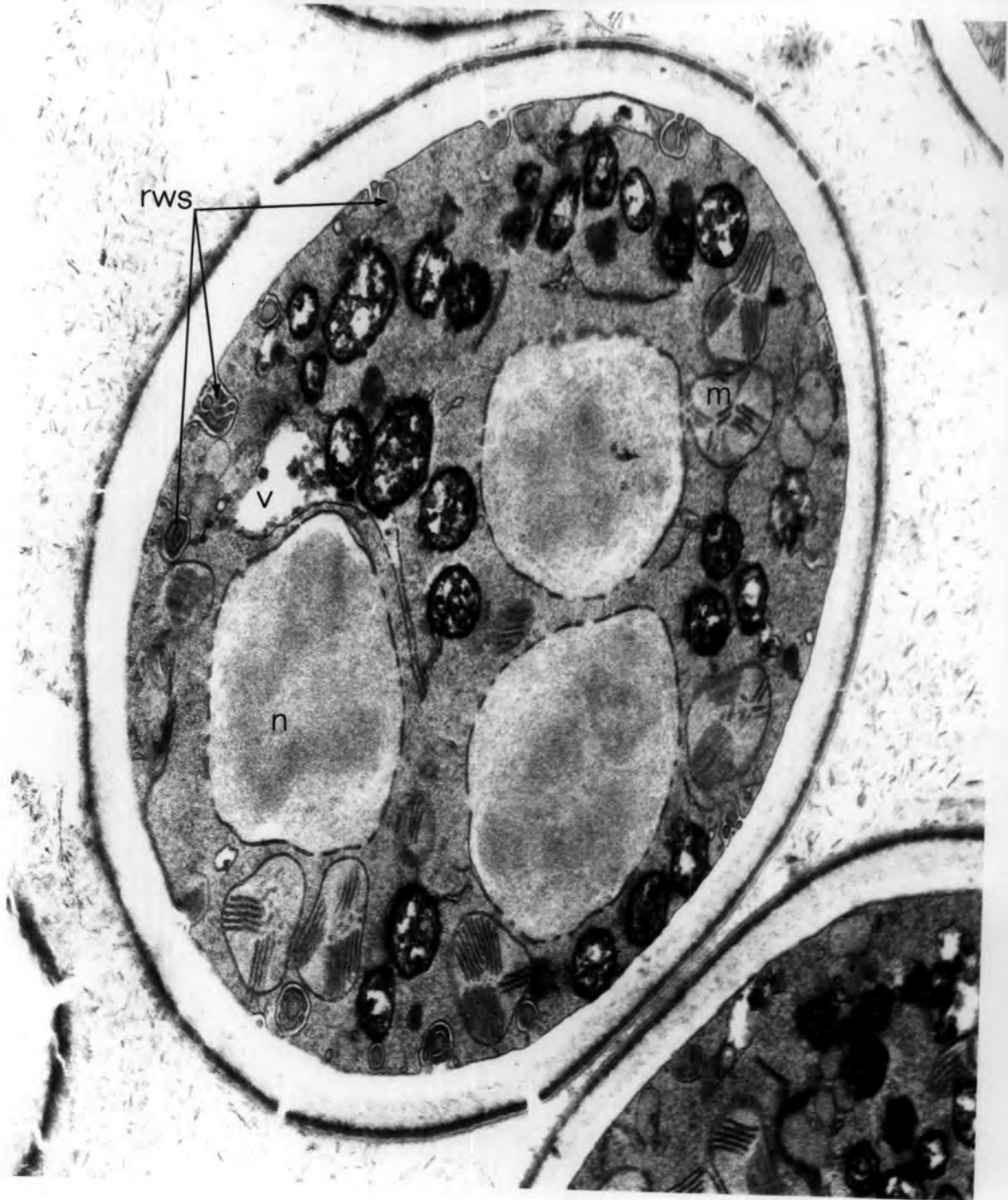

Fig.56. A spore at the late stage of maturation showing the reticulate wall systems. Note the absence of glycogen and the presence of a large irregular shaped vacuole.

X 23,120

The reticulate wall systems are similar to the bodies reported by Chet et al (1969) in hyphae of Sclerotium rolfsii and considered by them to be the vehicle by which wall material is elaborated. The disappearance of glycogen and some fat at the same time as the appearance of these systems and the initial development of the secondary wall layer suggests a relationship between the three phenomena. The relationship might well be the utilization of glycogen and some fat in the synthesis of the material of the secondary wall. The reticulate wall systems might represent a pumping or transport mechanism by which materials are transferred from the storage regions to the regions of wall synthesis. Such a system would of necessity depend upon the presence of a suitable enzyme systems. On the other hand, it might conceivably be that these systems are the actual sites of enzyme synthesis of wall components to which material is transferred by some other mechanism.

Marchant et al (1967) postulate the formation of primary and secondary wall layers in fungal hyphae by two distinct mechanisms. It may be that the involvement of two structurally distinguishable systems in the synthesis of a two layered wall is a characteristic feature of fungal wall synthesis.

The Mature Spore.

When fully mature the spores possess a two layered wall. The outer wall which was the first to be deposited is extremely electron dense and about 25 nm thick. The inner wall is not so electron dense, and is ~~slightly~~ thicker than the outer wall being about 14 μ m thick. Each mature spore contains several nuclei, numerous mitochondria, fragments of endoplasmic reticulum, usually some fat droplets and one or more vacuoles. In all

the mature spores examined the contents did not fully occupy the total volume within the spore wall, but this can probably be attributed to a degree of shrinkage during the preparation of the material.

VIIIId (viii) Sporangium Development.

Within the developing sporangium, cleavage of the sporangium contents always appeared to be total so that the spores were formed simultaneously. Nevertheless it was frequently observed that the inner spores, those closest to the columella appeared to mature far earlier than the outer spores, the former frequently having developed the secondary wall whilst the latter still only possessed the primary wall. (Fig. 57).

The Columella.

Simultaneous with spore wall development, wall material is deposited on the outside of the columella membrane thus forming a rigid barrier between the columella and the sporangium cavity. On completion the columella wall extends for some distance, about 0.05 mm down the sporangiophore wall, gradually decreasing in thickness until it finally coalesces with the sporangiophore wall.

On completion of development the area of the columella membrane is extensively increased by the development of irregular ingrowths of wall material which frequently branch and anastomose to form a complex network of wall material. The plasma membrane closely follows the contours of the wall material and cytoplasm is frequently found occupying the spaces between the framework. (Fig. 58).

Ingrowths of wall material have been reported by numerous authors as occurring in a wide variety of plant

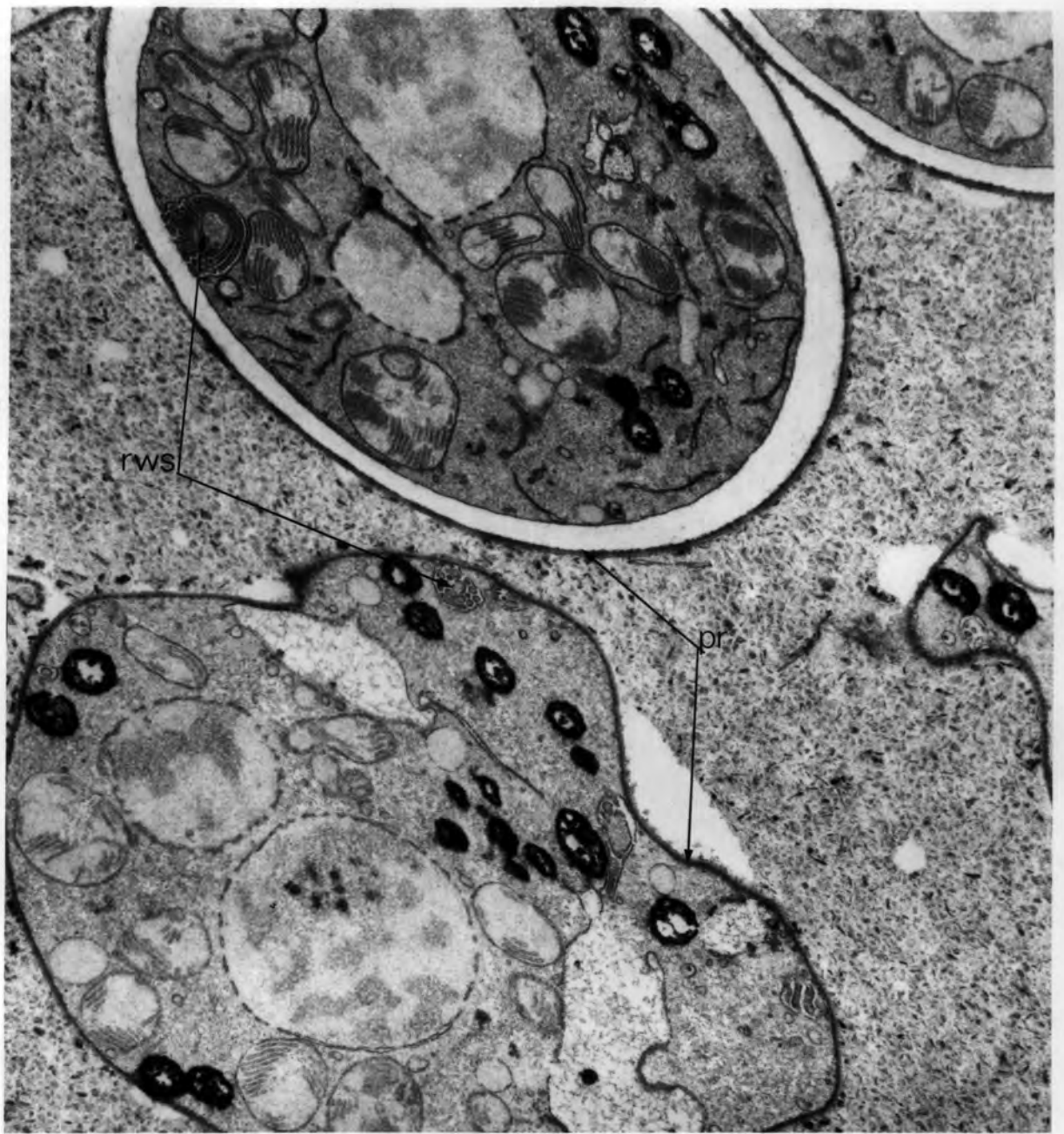

Fig. 57. Two spores at different stages of maturation.

Both contain at least one reticulate wall system. X 18,570

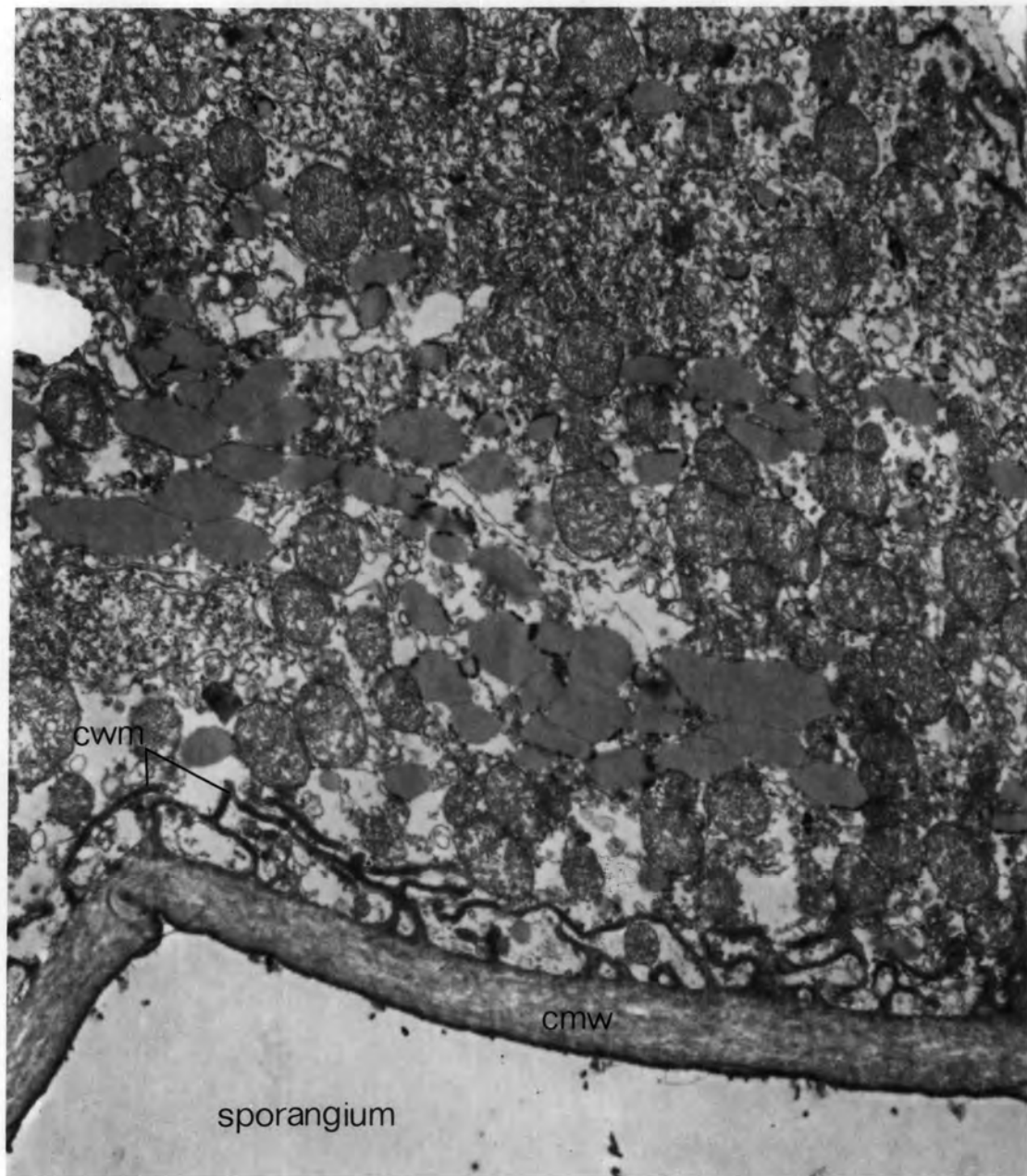

Fig. 58. Part of columella from within a Stage IV sporangium. There is an extensive development of wall material on the sporangiophore side of the columella septum. X 14,770

material including organs of several members of the Pteridophyta and Bryophyta and a few lichens. These findings have been reviewed by Gunning and Pate (1969) but in their paper entitled "Transfer Cells", they make no reference to the occurrence of such structures in fungi.

Transfer Cells (Gunning and Pate 1969) which are characterized by extensive wall ingrowths, are apparently restricted to areas where adverse surface area/volume relationships exist between adjacent cells forming part of a transport pathway, or to areas where the transported solutes are accompanied by a minimal flow of solvent. If the columella zone of the sporangiophore of Phycomyces is comparable in any way to transfer cells, then one has to postulate the transport of solutes across the columella membrane. Since these wall ingrowths only develop at a very late stage in sporangium development that is, when the spores are more or less fully developed, it is difficult to envisage any reason for the mass movement of solutes from the columella into the sporangium, since at this stage it is most unlikely that they will be incorporated into the sporeplasm. However, it is generally accepted that spore discharge in many fungi is dependent on either atmospheric or substrate water, and that osmotic forces are involved. This most likely, also applies to Phycomyces even though the final rupturing of the wall only results when contact is made. The development of the essential increase in turgor can only result from the build up of highly osmotic materials in the sporangium relative to the columella. It may therefore be that this extensive plasmalemma develops as

a means by which solutes can, by active membrane transport, be rapidly moved from the columella into the sporangial mass, where they will serve to maintain a concentration gradient leading to the build up of a turgor pressure sufficient to facilitate the eventual rupture of the sporangium wall.

In immature asci and in the immature active layer of Sphaerobolous spp. (Cochrane 1958) glycogen is abundant. Its disappearance at maturity has led to the suggestion that the uptake of water is mediated by enzymatic conversion of the osmotically inactive polysaccharides to osmotically active sugars, and that such a mechanism might be extended to cover all discharge mechanisms which depend on increasing turgor of cells.

Glycogen an abundant reserve in immature sporangia of Phycomyces as in asci and Sphaerobolus Spp. disappears at maturity. There is however, adequate evidence from the electron micrographs to support the view that the disappearance of glycogen from the spores of Phycomyces is the result of its involvement either directly or indirectly in the synthesis of spore wall material, and does not merely imply hydrolysis to produce a high concentration of osmotically active sugar that would facilitate the uptake of water.

In only one respect is this hypothesis at variance with the findings of Gunning and Pate on transfer cells in multicellular organisms. Transfer cells are restricted to situations where the flow of solvent is minimal to the flow of solutes. In Phycomyces I suggest that the activities of the large membrane area might, in fact, be responsible for initiating and maintaining a flow of solvent sufficient to bring about sporangium



dehiscence. Despite this fundamental difference I see no reason at this stage to discard this possible function of columella wall ingrowths.

It remains however, somewhat of a conjecture until such times as it is possible to investigate experimentally both the quantitative and qualitative solute content of the mature sporangium over a period beginning with the appearance of the columella wall ingrowths and ending just prior to sporangium dehiscence.

Another possible reason for the increased area of the columella plasmalemma might be the transport back into the sporangiophore of solutes remaining in the interspore material after the completion of spore formation. Such a mechanism would serve to prevent excessive loss of valuable nutrient materials which might otherwise occur during sporangium dehiscence. Although one cannot disregard the possibility of solute transport in this direction, it would seem highly improbable. As a result of cleavage the entire content of the sporangium becomes either incorporated within the spore or the columella. The remaining interspore material is the residue occurring within the cleavage vesicles themselves and it seems most improbable that these would possess valuable nutrients in quantities of economic importance to the mycelium.

Control of Wall Development.

The development of the wall ingrowths like that of the columella wall is in all events influenced by the unique morphological and physiological state that exists within the sporangium at the

termination of cleavage. Cross walls are not of common occurrence within the mycelium of Phycomyces and with a few exceptions are found only in this unique situation. It seems therefore not unreasonable to suppose that the stimulus initiating such an unusual event as the formation of the columella wall, might well also be responsible for the initiation of the development of the wall ingrowth.

It has been stated that in certain species e.g. Pisum, Impatiens, Sedum and Ligularia the frequency and intensity of wall ingrowths in transfer cells is influenced by the functions of the cell and its neighbours, and in others e.g. Vicia faba that their production is often synchronized with the onset of intensive transport (Gunning and Pate 1969) This being so, the development of ingrowths of the columella wall of Phycomyces might perhaps be regarded as another example of a modification in the evolutionary development of the wall membrane apparatus capable of facilitating a rapid short distance transport of materials to assist in the completion of maturation and dehiscence of the sporangium. There is however no data on which to base a theory of functional influence on the development of columella wall ingrowths. Nevertheless their presence might well have some significance.

VIIIe. Germination of the Spores.

The vegetative spores of Phycomyces, because of their low metabolic rate, may remain dormant for long periods of time when placed in an environment unsuitable for growth. Air dried spores placed in loosely stoppered tubes in a refrigerator have been kept viable for as long as four years (Bergman et al 1969) and lyophilized spores have been known to remain viable for as long as twenty three years

(Raper and Alexander 1945, Ellis and Robertson 1968 as reported by Bergman et al 1969).

Under suitable conditions the spores will germinate, although very few dormant spores will germinate immediately when provided with the materials required for growth. The most commonly used method of activating spores is heat shock.

VIIIe (i) Preparation of material for germination.

Spore suspensions were collected, incubated and germinated in the manner described previously in Section III.d. Eight to nine day old cultures of Phycomyces were usually used as the source of the spores and the spores usually produced from one to three germ tubes in about 5 hours after incubation.

Germination.

About one hour after incubation the spores begin to swell. The swelling was most pronounced at the ends of the long axis of the spore so that the latter gradually assumed a dumbbell shape, but as the swelling continued the spores become more globose. About 4-5 hours after incubation the spores were about twice their dimensions at the dormant state

4.1 μ x 7 μ m-dormant spore

8.2 μ x 11 μ m at the onset of germ tube emergence

As the swelling developed usually two vacuoles became apparent. These enlarged and coalesced at about the same time that the germ tube emerged. At this stage a single large vacuole occupied almost the whole of the spore volume.

VIIIe (ii) Electron Microscope Investigations.

Samples of spores were examined under the electron microscope at:-

- a) the end of 30 minutes after the initial incubation period
- b) the end of 2 hours after the initial incubation period
- c) on the emergence of the germ tube

Each sample was prepared for examination under the electron microscope in the manner previously described in Section III e.

Results.

The spores examined 30 mins after incubation were in ultrastructural detail similar to the dormant spores. At 2 hours after incubation, well formed vacuoles were apparent, the storage fat droplets had often completely disappeared, the cytoplasm was extremely dense and there was often a pronounced development of strands of endoplasmic reticulum. Just prior to the emergence of the germ tube the ultrastructural changes that had occurred within the swollen spore were for the most part changes in wall structure. The thin electron dense outer wall layer was still very much in evidence, but the inner wall layer appeared now in several places as a much more loosely bound structure than it did in the dormant spore; in some areas it had disappeared completely. Surrounding the cytoplasm a third layer of wall material, showing a fibrous nature in several places, was developing (Fig.59). At one or more points the plasma membrane was thrown into a series of irregular invaginations into the cytoplasm. In these areas the space thus formed between the plasma membrane and the third wall layer was occupied by a number of irregular shaped vesicles of varying sizes (Fig.60). At a later stage in the development the original spore walls completely disappeared from these areas, which were obviously destined to be the growing points of the germ tubes and subsequent first hyphae (Fig.61). The cytoplasm immediately behind the growing point was rich in mitochondria, which were often very much enlarged and elongated, small vesicles and pieces of endoplasmic reticulum, all features indicating an area of intense metabolic activity.

As a result of germination the spores of Phycomyces,

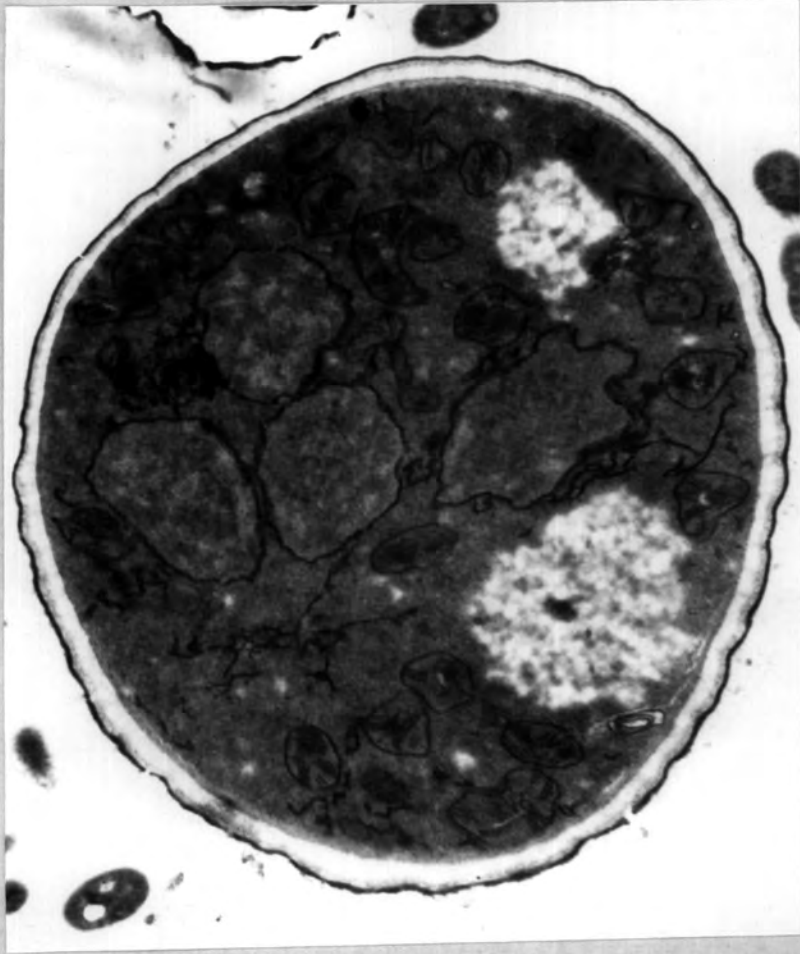

Fig.59. Spore 2 hours after incubation in potato extract at 20°C a third wall layer is just visible within the original spore wall. X 15,000
Fig.60. The emergence of the germ tube - the original spore wall has disappeared. Note the numerous, large mitochondria near the growing lip. X 15,000



Fig.
59.

Fig. 60.

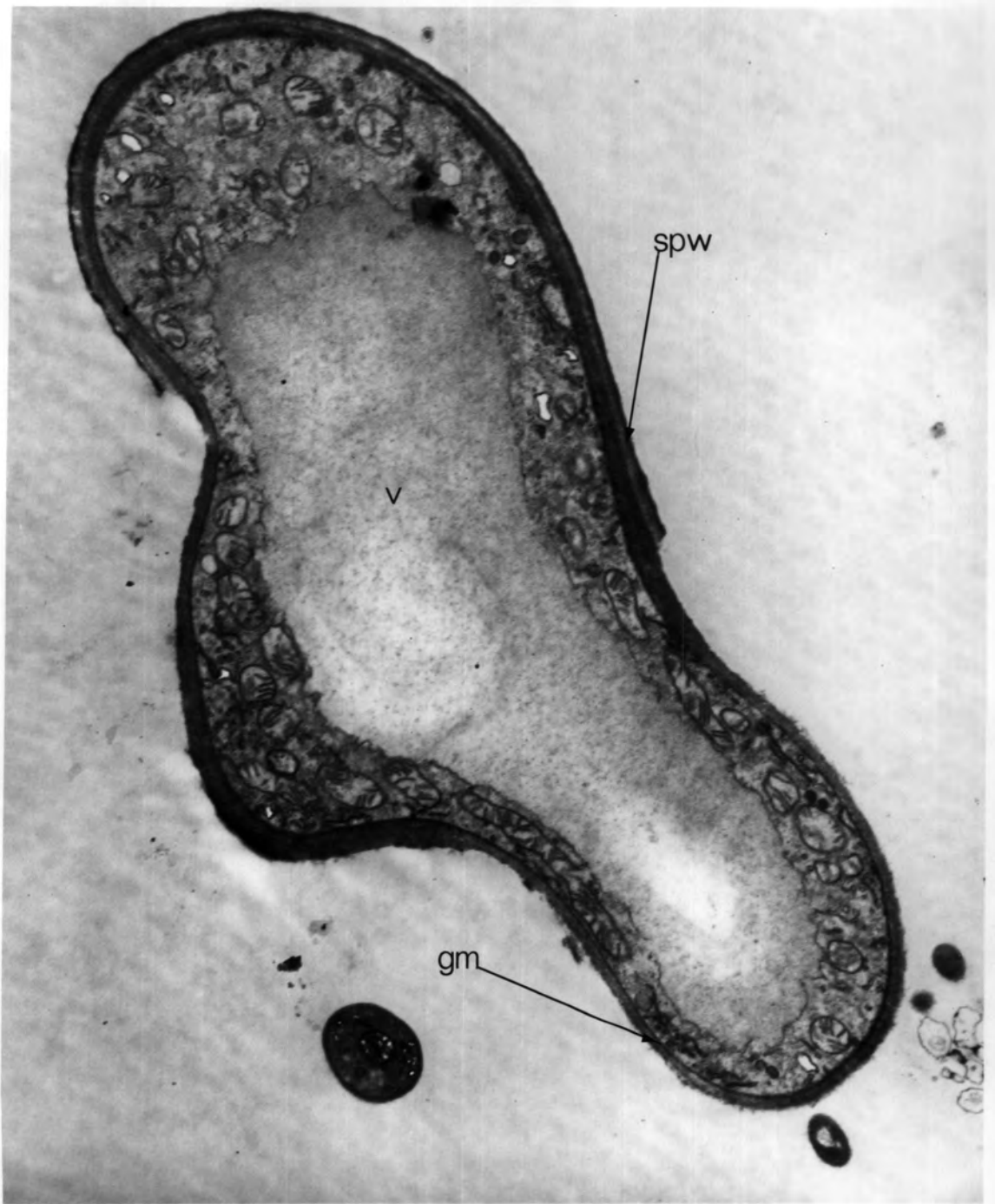

Fig. 61. Germinating spore five hours after
incubation.

X 11,560

like those of many germinating fungal spores, show a general increase in cell organelles. There is a rapid build up of endoplasmic reticulum and a marked increase in mitochondrial population. It could not however be claimed that the increase in mitochondrial population in the germinating spores is accompanied, as in the case of some spores, (Luck, 1963) by a reduction in mitochondrial size, since some of the largest mitochondria ever observed by me in Phycomyces occurred in the germinating spores. If the increase in mitochondrial population is obtained by the division of the existing mitochondria, this division must be accompanied by a rapid process of organelle enlargement. Since the development of the third wall layer within the spore, and the subsequent germ tube wall, is accompanied by the disappearance of the fat globules it would seem reasonable to suggest that the latter is in some way involved in the production of wall material. The chitin wall of Phycomyces has been shown to contain up to 25% of waxy or fatty compounds readily extracted by carbon tetrachloride (Kreger, 1954) so it may thus be that at least part of the fatty material within the cytoplasm of the spore is used strictly as a constituent of the wall material during wall synthesis.

Attempts were made to germinate spores in a medium containing tritiated glucose in the hope that it might be possible to learn something of the mechanism by which wall material is synthesised in Phycomyces spores. Unfortunately the spores constantly showed a very low uptake of the radioactive material so that these attempts proved unsuccessful, perhaps to some extent because the spores always contained wall constituents or their precursors in adequate supply in the storage materials. It is more likely,

since spores will not germinate unless a nutrient medium is supplied, that glucose is not normally taken up from the growth medium although it may be required for germination. The results of Ekundayo and Carlile (1964) and Ekundayo (1966) indicate that in Rhizopus glucose could be metabolised on the surface of the organism to bring about permeability changes necessary for cell extension. The uptake of water by the spores of Rhizopus arrhizus required the presence of glucose. The rate of water uptake per unit area of spore surface remained unchanged, as the volume of spore increased. These facts suggest that the process was an active one and not osmotic.

The glucose might be used to generate NADH_2 which could reduce the disulphide linkages in the protein component of the wall to sulphydryl groups, and so increase the plasticity of the wall.

The exact chemical composition of the wall of Phycomyces is still unknown (Bergman et al 1969); nevertheless the chitin fibrils, which are known to make up about 25% of the wall material, consist of polymers of 1-4 glucoside linkages, like cellulose; the glucose residues being N-acetylglucosamine instead of glucose. Work on the synthesis of chitin in certain crustacea has shown that it is glucosamine which is readily incorporated into the chitin fibrils.

Nevertheless even if the appropriate amino acids and nitrogen bases required for the synthesis of wall materials were not present in the growth medium provided it is difficult to explain the apparent absence of glucose uptake by the spores.

The results obtained suggest that the germinating spores and isolated hyphae possess sufficient reserves of

glucose or materials from which glucose can be derived to make them independent of the external medium.

Ville (iii) The Germ Tubes.

The young germ tubes (Fig.62) contain dense cytoplasm, a relatively high proportion of endoplasmic reticulum, and numerous mitochondria; also in transverse section several small electron dense bodies were apparent. The cytoplasm was bounded by a single wall layer about 13 nm thick. There was no evidence of this wall material ever having been surrounded by the cuticle commonly found in Phycomyces sporangiophores.

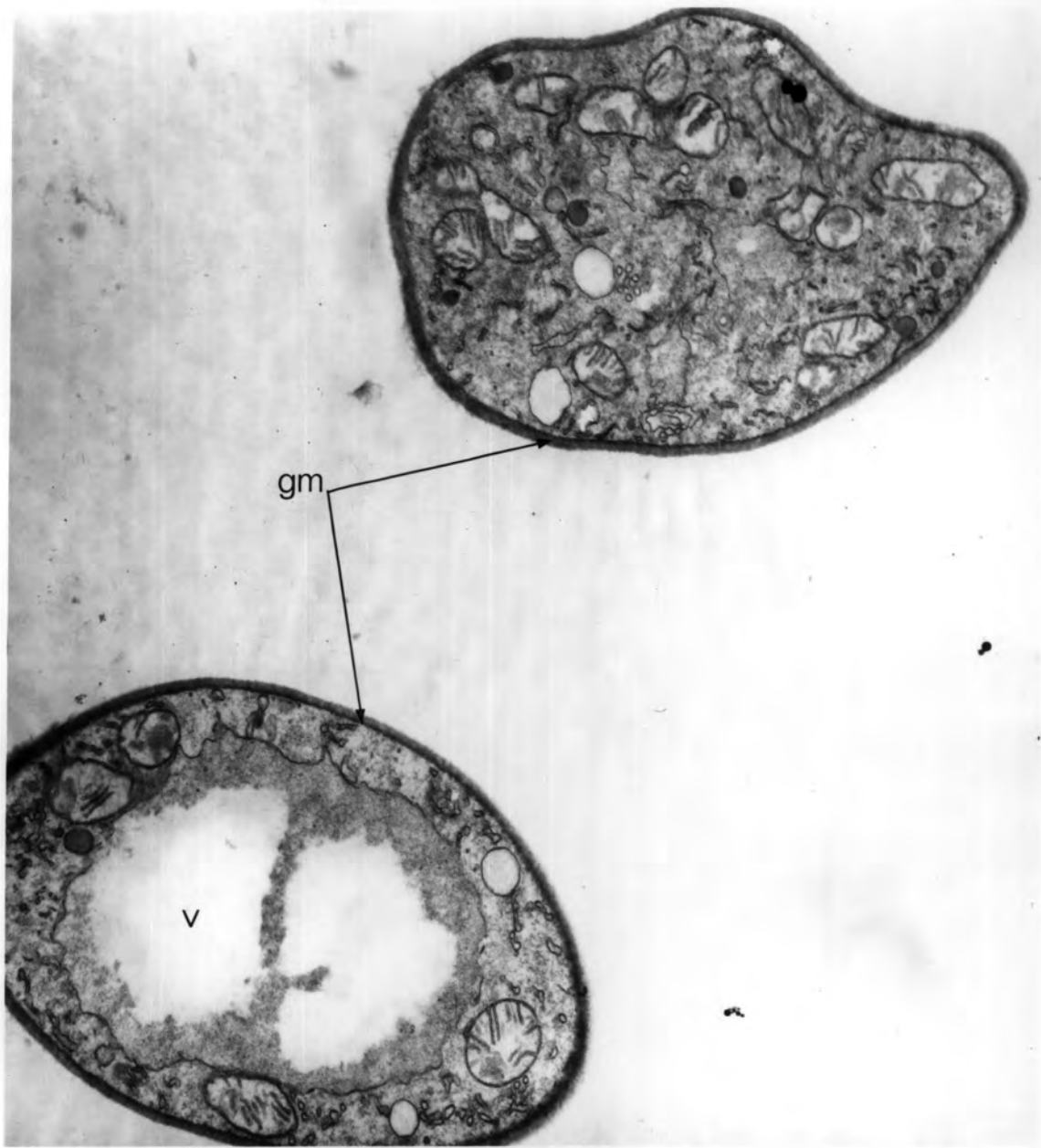

Fig. 62. Transverse sections of a very young and older germ tube. There is no indication of the presence of a cuticle.

X 15,460

Abbreviations.

cl - cleavage vesicle; cm - columella; ct - cisterna;
cmw, columella wall; cvs - central vacuole of
sporangiophore; cw - cell wall; cwm- cell wall material

er - endoplasmic reticulum;

f - fat droplet;

g - glycogen; gm - germ tube wall;

i - interspore material;

lo- lomasome like body;

m - mitochondrion; mf - microfilament; mi- membrane
invagination; mv - microvesicle; ms - membrane stack;

n - nucleus; ne- nuclear evagination; no - nucleolus;
np - nuclear pore;

pl- plasmalemma; pr - primary wall layer; pv-pleomorphic
vesicle

r - rod like body; rws - reticulate wall system;

sp - spore mass; spw - spore wall; sw - secondary wall
layer; sv - spherical vesicle;

v - vacuole; ver - vesicle of endoplasmic reticulum;
vs - vesicle;

BIBLIOGRAPHY.

- AUDUS, L.J., The Mechanism of the perception of gravity, by plants. Sympos. Soc. Experiment. Biol 16, 197-226 1962
- BANBURY, G.H., Physiological Studies in the Mucorales. Journal of Experimental Botany. 3, 77-94 1952
- BANBURY, G.H., Phototropism of lower plants. Encyclopedia of Plant Physiology. Springer-Verlag. Berlin xvii/i 530-578 1959
- BARTON, R., Autoradiographic Studies on wall formation in Chara. Planta (Berl.) 82, 302-306 1968
- BENJAMIN, C.R., & HESSELTINE, C.W., Studies on the genus Phycomyces. Mycologia 51, 751-771 1959
- BERGMAN, K., et al., Phycomyces. Bacteriological Reviews 33. 1., 99-157 1969
- BLAAUW, A.H., Licht und wachstum I. Zeitschrift Botan 6, 641-703 1914
- BLAAUW, A.H., Licht und wachstum III. (Die Erklärung des Phototropismus) Mededeelingen Landbouwhoogeschool Wageningen 15, 89-204 1918
- BLAKESLEE, A.F., Sexual reproduction in the Mucorineae Am. Acad. Arts. Sci. 40 205-319 1904
- BRACKER, C.E., Ultrastructural aspects of sporangiospore formation in Gilbertella persicaria. In "The Fungus spore." Proc. Sym. Colston Res. Soc., 18th Bristol, England. (Madelin, N.F., Ed. Butterworths, London) 39-60 1966
- BRACKER, C.E., Ultrastructure of Fungi. Ann. Rev. Phytopathol 55, 343-367 1967

- BUCKLEY, P.M., SJAHOLM, V.E., and SOMMER, N.F., Electron Microscopy of Botrytis cinerea conidia. Journal of Bacteriology 91, 2037-2044 1966
- BURGEFF, H., Uber arten und artkreuzung in der gattung Phycomyces. Kunze. Flora 118-119, 40-46 1925
- BURGEFF, H., Pflanzliche avitaminose und ihre behebung durch vitaminzufuhr. Ber. Deut. Botan. Ges. 52 384-390 1934
- CALOGNE, F.D., FEILDING, A.H., & BYRDE, R.J.W., Multivesicular bodies in Sclerotinia functigena and their possible relation to extracellular enzyme secretion. Journal of General Microbiology. 55, 177-184 1969
- CASTLE, E.S., Dark adaptation and the dark growth response of Phycomyces. Journal of General Physiology 16, 75-88 1932
- CASTLE, E.S., The refractive indices of whole cells. The physical basis of the positive phototropism of Phycomyces. Journal of General Physiology 17, 41-62 1933
- CASTLE, E.S., Spiral growth and the reversal of spiraling in Phycomyces and their bearing on primary wall structure. American Journal of Botany 29, 664-672 1942
- CASTLE, E.S., The topography of tip growth in a plant cell. Journal of General Physiology 41, 913-926 1958
- CASTLE, E.S., Growth distribution in the light growth response of Phycomyces. Journal of General Physiology 42, 697-702 1959
- CHET, I., HENIS, Y., & KISLEV, N., Ultrastructure of sclerotia and hyphae of Sclerotium rolfsii (Sacc). Journal of General Microbiology 57, 143-147 1969
- CRAWLEY, J.C.W. , Fine structure and cytoplasmic streaming in Physarum polycephalum. Journal of the Royal Microscopical Society 85, pt III, 313-322 1966
- COCHRANE, V.W., The physiology of fungi. John Wiley and Sons, N.Y. 1958

- DAVIS, L.E., Intramitochondrial crystals in Hydra. Journal of Ultrastructural Research 21, 125-133 1967
- DELBRÜCK, M., & REICHARDT, W., Systems analysis for the light growth reaction of Phycomyces. In "Cellular mechanisms in differentiation and growth". Ed. Runich, D., Princeton University Press 3-44 1956
- DENNISON, D.S., Tropic responses of Phycomyces sporangiophores to gravitational and centrifugal stimuli. Journal of General Physiology. 45, 23-38 1961
- EKUNDAYO, J.A., & CARLILE, M.J., The germination of sporangiospore of Rhizopus arrhizus; Spore swelling and germ tube emergence. Journal of General Microbiology 35, 261-269 1964
- EKUNDAYO, J.A., Further studies on germination of sporangiospores of Rhizopus arrhizus. Journal of General Microbiology 42, 283-291 1966
- FRANKE, W.W., KRIENS, S., & BROWN M.R., Jr. Simultaneous gluteraldehyde-osmium tetroxide fixation with postosmication. Histochemie. 19, 162-164 1969
- GLAUERT, A.M., & GLAUERT, R.H., Araldite as an embedding medium for electron microscopy. Journal of Biophysics, Biochemistry and Cytology 4, 115 1958
- GUNNING, B.E.S., and PATE, J.S., "Transfer Cells" Plant cells with wall ingrowths specialized in relation to short distance transport of solutes - their occurrence, structure and development. Protoplasma 68, 107-133 1969
- HARPER, R.A., Cell division in sporangia and asci. Annals of Botany 13, 467-525 1899
- HAWKER, L.E., Fine structure of fungi as revealed by electron microscopy. Biological Reviews 40, 52-92 1965
- HAWKER, L.E., and ABBOTT, P.McV., An electron microscope study of maturation and germination of sporangiospores of two species of Rhizopus. Journal of General Microbiology 32, 295-298 1963
- HAWKER, L.E. and HENDY, R.J., An electron microscope study of germination of conidia of Botrytis cinerea. Journal of General Microbiology 62, 129-137 1963
- HAWKER, L.E., and ABBOTT, P.McV., Fine structure of the young vegetative hyphae of Pythium debaryanum. Journal of General Microbiology 31, 491-494 1963

- HEATH, I.B., and GREENWOOD, A.D., Structure and Formation of lomasomes. *Journal of General Microbiology* 62, 129-137 1970
- HEUCKEL, A., Le phototropisme des Mucorini. *Bull. Inst. Rech. biol. St. Biol. Univ. Perm.* 5, 307-310 1927
- ISAAC, P.K., Cytoplasmic streaming in filamentous fungi. *Canadian Journal of Botany* 42, 787-792 1964
- JAHN, T.L., and BOVEE, E.C., Protoplasmic movements within cells. *Physiological Reviews* 49, 793-862 1969
- JONES, R.C., The feulgen reaction as a cytological technique with Allomyces arbuscula. *Mycologia* 34, 109-112 1947
- KAMIYA, N., Protoplasmic streaming. *Protoplasmatologia*. viii/3/a Springer-Verlag Wein. 1959
- KANE, R.E., The mitotic apparatus - Fine structure of the isolated unit. *Journal of Cell Biology* 15, 279-287 1962
- KORSON, R., A differential stain for nucleic acid. *Stain Technology* 26, 265-270 1951
- KAVANAU, J.L., Protoplasmic streaming as a process of jet propulsion. *Developmental Biology* 7, 22-37 1963
- KAY, D., (edt) *Techniques in electron microscopy*. Blackwell Scientific Publications Ltd., Oxford 65-67 1961
- KREGER, D.R., Observations on cell wall of yeasts and some other fungi by X-ray diffraction and solubility tests. *Biochem. Biophys. Acta* 13, 1-9 1954
- LEDBETTER, M.C., and PORTER, K.R., A 'microtubule' in plant cell fine structure. *Journal of Cell Biology* 19, 239-250 1963
- LUCK, D.J.L., Formation of mitochondria in Neurospora crassa quantitative radioautographic study. *Journal of Cell Biology* 16, 483-499 1963
- LUFT, J.H., Permanganate - a new fixative for electron microscopy. *Journal of Biophysics, Biochemistry and Cytology* 2, 799-801 1957
- MARCHANT, R., PEAT, A., and BANBURY, G.H., The ultrastructural basis of hyphal growth. *New Phytologist* 66, 623-629 1967

- MEISSNER, G., and DELBRÜCK, M., Carotenes and retinal in Phycomyces mutants. Plant Physiology 43, 1279-1283 1968
- MERCER and BIRBECK. Electron Microscopy. Blackwell Scientific Publications. 1961
- MOHR, W.P., and COCKING, E.C., A method of preparing highly vacuolated, senescent or damaged plant tissue for ultrastructural study. Journal of Ultrastructural Research 21, 171-181 1968
- MOORE, R.T., and McALEAR, J.H., Fine structure of mycota. V Lomasomes-previously uncharacterized hyphal structures. Mycologia 53, 194-200 1961
- NAGAI, R., and REBHUN, L.I., Cytoplasmic microfilaments in streaming Nitella cells. Journal of Ultrastructural Research 14, 571-589 1966
- OORT, A.J.P., and ROELOFSEN, P.A., Spiralwachstum wandbau und plasmaströmung bei Phycomyces. Koninkl. Ned. Akad. Wetenschap. Proc. 35, 898-908 1932
- ORTEGA, J.K.E., and GAMOW, R.I., Phycomyces: habituation of the light growth response. Science 168, 1374-1375 1970
- PEAT, A., and BANBURY, G.H., Ultrastructure, protoplasmic streaming, growth and tropisms of Phycomyces sporangiophores. New Phytologist 66, 475-484 1967
- PEAT, A., and BANBURY, G.H., Occurrence of ferritin-like particles in a fungus. Planta 79, 268-270 1968
- PEAT, A., and WHITTON, B. A., Environmental effects on the structure of the blue-green alga Chlorogloea fritschii Archive für Mikrobiologie 57, 155-180 1967
- POP, L.J.J., Protoplasmic streaming in relation to spiral growth in Phycomyces. Proceeds of the Med. Akad. Wet. 41 ii, 661-672 1938
- ROELOFSEN, P.A., Cell wall structure in the growth zone of Phycomyces sporangiophores. II Double refraction and electron microscopy. Biochem. Biophys. Acta. 6, 357-373 1951
- ROELOFSEN, P.A., The plant cell wall. Encyclopedia of plant anatomy III (4) 298-305 Berlin 1959

- ROTH, L.E., Primitive motile systems in cell biology
p.527 Eds. Allen, R.D., and Kamiya, N., Academic
Press New York, 1964
- SABNIS, D.D., and JACOBS, W.P., Cytoplasmic streaming
and microtubules in the coenocytic marine alga
Caulerpa prolifera. Journal of Cell Science 2,
465-472 1967
- SCHOPFER, W.H., Versuch über die Wirkung von reinen
kristallisierten vitamin B auf Phycomyces Ber. Deut.
Botan. Ges. 52, 308-312 1934
- SCHWAB, D.W., JANNEY, A.H., and SCOLA, J., Preservation
of fine structure in yeast by fixation in dimethyl
sulfoxide - acrolein - gluteraldehyde solution.
Stain technology. 45; 4 143-147 1970
- SCHWARZE, C.A., The method of cleavage in sporangia of
certain fungi. Mycologia 14, 143-172 1922
- SITTE, P., Einfaches verfahren zur stufenlosen gewebe-
entwässerung für die electronenmikroskopische
präparation. Die Naturwissenschaften 17, 402-403
1962
- STRASBURGER, E., Zellbildung und Zelltheilung 3rd ed. 1880
- SWINGLE, D.B., Formation of the spores in the sporangia
of Rhizopus nigricans and of Phycomyces nitens. U.S.
Department of Agriculture Bulletin 37, 5-40 1903
- THORNTON, R.M., The fine structure of Phycomyces. I
Autophagic vesicles. Journal of Ultrastructural
Research 21, 269-280 1968
- THORNTON, R.M., The fine structure of Phycomyces. II
Organization of the stage I sporangiophore apex.
Protoplasma 66, 269-285 1968
- VILLIERS, T.A., Intranuclear crystals in plant embryo
cells. Planta (Berl) 78, 11-16 1968
- WILSENACH, R., and KESSEL, M., The role of lomasomes in wall
formation in Penicillium vermiculatum. Journal of
General Microbiology. 40, 401-404 1965

WOHLFARTH-BOTTERMANN, K.E., Differentiation of the ground cytoplasm and their significance for the generation of motive force of amoeboid movement. In "Primitive motile systems in Cell Biology." Eds Allen, R.D., and Kamiya, N., Academic Press New York. 79 1964

WOLKEN, J.J., Microspectrophotometry and the photoreceptor of Phycomyces I. Journal of Cell Biology 43, 353-360 1969

ZANKEL, K.L., BURKE, P.V., and DELBRÜCK, M., Absorption and screening in Phycomyces. Journal of General Physiology. 50, 1893-1906 1967

A C K N O W L E D G M E N T

I wish to thank Mr. G. H. Banbury for his help and encouragement throughout this work.

I would also like to thank Mr. A. Cobb and Mr. R. Swinhoe for their assistance with the photography.

