

Durham E-Theses

A learning programme in geography

Elizabeth Sheperd

How to cite:

Sheperd, Elizabeth (1971) A learning programme in geography. Masters thesis, Durham University.

Use policy

The full-text may be used and/or reproduced, and given to third parties in any format or medium, without prior permission or charge, for personal research or study, educational, or not-for-profit purposes provided that:

- a full bibliographic reference is made to the original source
- a <https://etheses.durham.ac.uk/id/eprint/10378/> is made to the metadata record in Durham E-Theses
- the full-text is not changed in any way

The full-text must not be sold in any format or medium without the formal permission of the copyright holders.

Please consult the [full Durham E-Theses policy](#) for further details.

ABSTRACT

A learning programme, on the topic of glaciation, is written for pupils of above average intelligence for use in the school situation. The learning programme is linear in style with overt response. It consists of 144 frames divided into five sections. Pupils work at their own pace within the lesson period.

First year pupils in a Senior (13+-18+) High School assisted in programme development. Four revisions were found to be necessary before the learning programme was considered to be satisfactory (Gain Ratio of 1.2). Revisions were based on the pupils' post-test performance and the frame response error rate. The final version of the programme produced a Gain Ratio of 1.38. Overall frame response errors were 5.8% and key frame response errors 6.92%.

The map interpretation section of the programme did not reach an acceptable level of success. The pupils concerned may have lacked the necessary basic map reading skills.

The Gain Ratio for the whole programme after a period of one month is 0.87.

Programme evaluation followed with a teaching methods experiment. The learning which resulted from the use of ~~the~~ three different teaching methods was analysed. The teaching methods employed were (1) learning programme only; (2) learning programme plus discussion; and (3) normal method. A comparison of the results obtained from the three

groups for (i) post-test gains;
(ii) retention gains (5 weeks later);
(iii) G.C.E. theory and (iv) G.C.E. map interpretation
(9 weeks later) all yielded results of no significant
difference. The learning programme was as effective as the
other teaching methods and required less time.

It is suggested that the type of O.S. map
interpretation used in the learning programme may be
too difficult for pupils in the 13+ - 14+ age group.

Elizabeth SHEPHERD

M.Ed. Thesis to be presented to the University of Durham

September 1971.

The writing, validation and evaluation of a learning
programme in Geography for prospective 'O' level
candidates.

ACKNOWLEDGEMENTS

My thanks are due to:

The Ordnance Survey for permission to use map extract
No. 226/82.

Aerofilms Ltd. for permission to use three aerial
photographs.

The Headmistress of St. Mary's High School for permission
to experiment with the learning programme in the school.

The third form pupils for their enthusiastic involvement.

My colleagues for their criticisms and suggestions.

Mrs. B. G. Fraser B.Sc., Ph.D., for advice on programme
construction.

Mr. C. S. Blake B.Sc. for comments arising from his
article presented to the NCPL in 1966.

My tutor, Mr. B. B. Hartop M.A., for his patience,
encouragement and stimulating comment.

<u>CONTENTS</u>	page
Acknowledgements	
Contents	1
Appendices	1
List of Tables	3
List Figures	5
Introduction	6
Chapter 1 The Problem.	9
Chapter 2 Programmed Learning - Its Characteristics and Development	10
Chapter 3 Relevant Literature	18
Chapter 4 Programme Construction I - Analysis	30
Chapter 5 Programme Construction II - Synthesis	50
Chapter 6 Validation	73
Chapter 7 Programme Evaluation I - The Experiment	101
Chapter 8 Programme Evaluation II - Statement and Discussion of Results	113
Summary and Conclusions	123
Bibliography	127
 <u>Appendices</u>	
(i) G.C.E.'O' Level questions on glaciation 1963-70	136
(ii) Learning Programme Section Tests	138
(iii) The learning programme	143
(iv) Questionnaire	144
(v) Learning programme - First Version	145

	Page
(vi) Learning programme - Second Version	150
(vii) Field Test 1 Post-Test Analysis and Frame Response Error Rates	157
(viii) Learning Programme - Third Version	161
(ix) Analysis and Recording of Programme Structure - Sections 2 - 5	163
(x) Field Test 2 Post-Test and Retention Test Analysis	168
(xi) Final Validation Test Data	175
(xii) Tests used in the Comparative Experiment	181
(xiii) Criterion Test Results used in the Comparative Experiment	183

LIST OF TABLES

	Page
3.1 The Results of 112 Studies comparing Programmed with Conventional Instruction	27
3.2 Results of Comparative Studies carried out in Schools	27
4.1 Stages in Programme Development	30
4.2 Teaching Point and Task Analysis	43
5.1 Sectional Content of the Learning Programme	53
5.2 Teaching Point Arrangement within Programme Sections	54
6.01 Field Test 1 - Pre-test Scores	80
6.02 Field Test 2 - Post-Test Scores	80
6.03 Field Test 1 - Post-Test Analysis for Section 2	81
6.04 Field Test 1 - Frame response error % scores - Section 2	82
6.05 Field Test 1 - Mean Programme Working Times	83
6.06 Field Test 2 - Pre-Test Scores	84
6.07 Field Test 2 - Post Test Scores	84
6.08 Field Test 2 - Summary of Teaching Point Success as indicated by Post-Test Results	85
6.09 Field Test 2 - Reversals	86
6.10 Field Test 2 - Retention Test Scores	87
6.11 Field Test 2 - Summary of Teaching Point Success as indicated by the Retention Test	87
6.12 Field Test 2 - Programme Working Time	88
6.13 Final Validation - Pre-Test Scores	92
6.14 Final Validation - Post Test Scores	92

	Page
6.15 Final Validation - Frame Response Errors	93
6.16 Final Validation - Gain Ratios for 4 Sections only	94
6.17 Final Validation - Frame Response Errors (4 Sections)	94
6.18 Final Validation - Retention Test Scores	95
6.19 Final Validation - Programme Working Time	95
6.20 Questionnaire - Order of Preference for Geography	97
7.1 Time-Table for Experimental Groups	105
7.2 Absentees from Experimental Groups	107
7.3 Experimental Design - Teaching Methods and Tests	108
8.01 Analysis of Variance - General Intelligence	113
8.02 Analysis of Variance - Pre-Test Scores	114
8.03 Comparison of Pre- and Post-Test Results within each Teaching Group	115
8.04 Post-Test Gains for the three Teaching Groups	115
8.05 Analysis of Variance - Post Test Gains	116
8.06 Mean Post-Test Gain Scores for two Ability Grades in three Teaching Groups	116
8.07 A Comparison of Gain Scores for two Ability Grades in three Teaching Groups	117
8.08 Analysis of Variance - Retention Test Gains	118
8.09 Analysis of Variance - G.C.E. glaciation theory	119
8.10 Analysis of Variance - G.C.E. map interpretation	119

LIST OF FIGURES

	Page
4.1 Programme Construction Task Analysis	31
5.1 The three Components of a Frame	56
5.2 Analysis and Recording of Programme Structure	71
6.1 Learning Programme Validation Procedure	77

INTRODUCTION

As this century progresses the demand for education at all levels gathers momentum. This trend became evident, in the first instance, in the industrial nations but has spread to the underdeveloped areas of the world. In an industrial nation, such as Britain, this change of outlook results from two main causes. Firstly, a much wider section of society has become aware of the right of all to equal opportunities and education is seen as the main instrument in achieving this expectation. Secondly, the increasing complexity of modern life in the Space Age results in the demand for large numbers of highly-skilled men and women. Human resources which are not developed and utilized to the full are a loss to the country as a whole, as well as to the individuals concerned.

An increase in educational opportunity was facilitated, in Britain, by the Butler Act of 1944, which aimed at providing 'secondary education for all', followed later by Robbins' (1963) insistence that 'courses of higher education should be available for all who are qualified by ability and attainment to pursue them and who wish to do so'.

The number of pupils electing to remain in full time education, in this country, increases each year. By 1980 it is estimated that the number of extra school

children will be in the region of 3 million¹. In order to maintain the present staffing ratio an additional 170,000 teachers will be required by 1980. Because education requires a great deal of expensive labour there is an increasing need for teaching methods to be reviewed in order to make the most efficient use of all resources available. At the same time new teaching methods, techniques and materials must be developed and assessed so that standards of education already achieved can be maintained and improved. The developments in educational technology which are taking place at the present time will permit a more effective use of manpower. Programmed learning is one of the recent developments in this field.

The main objective of this exercise is to develop an efficient piece of instructional material in the form of a learning programme and to demonstrate its effectiveness. The learning programme illustrates the fact that this particular type of content material can be programmed and that when the programme is used by pupils it is as effective as some other instructional methods which are in current use. Evidence will also be given which suggests that programmed learning often requires less student time and effort to produce the same results.

1 Paper by Professor Maurice Preston

'Manpower and Resources 1966-80' presented to a National Conference at University of Sussex. May 1966.

This particular learning programme is concerned mainly with verbal, visual and diagrammatic skills because these seemed appropriate to the subject matter. However, many subjects can be programmed, using a wide variety of audio, visual and motor skills and materials. Programmed learning is much more than a collection of teaching aids; it is the efficient assembly of various teaching materials.

As a result of developments in programmed learning in the last 10 years teachers will increasingly present their knowledge in a more scientific objective way. Much more time will be spent isolating aims, writing and ordering learning sequences and evaluating results. This more systematic approach to the problem of teaching should produce better results as well as a more efficient employment of time and resources.

Programmed learning in the early stages of its development, was feared by some because it was thought that it would replace the teacher, Others thought that it had arrived at an opportune moment, at a time when the demand for teachers was outstripping supply, a time when the number of students and the syllabus content were growing much faster than the number of teachers and the aids available to them.

Chapter 1

THE PROBLEM

This study is concerned with the development of a new learning programme and attempts to ascertain its usefulness in the field of education. This estimate of value is investigated in two ways; firstly by attempting to assess the amount of learning which occurs as a direct result of its application and secondly by comparing its performance with other methods of teaching the same content material.

Initially an attempt is made to write a learning programme which is suitable for secondary school pupils preparing for the 'O' Level examination in Geography and the programme is to include the requirements of this examination on the topic of glaciation in the physical geography section. The learning programme is planned and written in the light of current theory and practice in programming.

Once written it is subjected to trial by students who are preparing for the 'O' Level geography examination. The initial learning programme is revised until the performance of these representative students suggests that an acceptable level of learning has occurred - this is the validation process.

Finally the learning programme is subjected to an evaluation procedure in that its performance is compared with other accepted teaching methods in a detailed empirical investigation.

Chapter 2

PROGRAMMED LEARNING - ITS CHARACTERISTICS AND DEVELOPMENT.

What is programmed learning?

Programmed learning is a method of teaching which has developed considerably over the last 10 years. The learning programme is a planned sequence of instructional material which the learner works through at his own pace. The material is arranged in small steps which require a frequent active response from the learner. Immediate knowledge of the accuracy of the response is an integral part of the process. The learning material was at first presented in book form or as a sheet in a teaching machine.

The preparation of the instructional material requires the learning objectives to be formulated in behavioural terms. This permits the learning programme to be tested by student performance and revised until the desired results are achieved.

At first learning programmes relied mainly on verbal presentation but many new programmes employ visual, tactile and auditory stimuli where more appropriate. Stones (1968) argues that in much secondary teaching entirely verbal programmes are inappropriate. He suggests that at these levels a programme must make use of integrated ancillary material. This is facilitated by developments in the availability and use of audio-visual aids, simulators and apparatus for teaching generally.

It is evident that programmed learning can also be presented in a much wider variety of forms. The programmed book, teaching machine, film, television and tape are all suitable media for presentation.

Programmed material is now more frequently integrated with other teaching techniques in the presentation of course material. In this way the appropriate teaching technique can be employed to accommodate a number of teaching aims and the variety of presentation assists motivation.

Characteristics of programmed learning.

A learning programme is a structured teaching instrument designed to produce specified changes in student behaviour. An outline is given at this point of a number of basic principles on which programmed learning is based. These principles have been developed and modified as a result of research findings.

1. Behavioural analysis The task to be performed is analysed into its component parts. Thus each stage is recognised and can be presented in a logical sequence.
2. Small steps The step size is usually quite small but the aim is to achieve the largest step size possible for an acceptable level of learning to result (Gilbert 1962, Markle 1963). Step size is governed by the difficulty of the content material and the age and ability of the students.
3. The pupil must actively participate at each stage and will learn as a result of the responses made.

4. Immediate knowledge of results As soon as a response is made correctness is ascertained. A correct answer promotes learning by (i) confirming the response, (ii) assisting in motivation.

5. Self-pacing The student works through the learning programme at his own speed. While this may assist the slow or quick learner in the classroom situation recent research on individual paced and group programming exercises shows that self-pacing is not essential for learning to occur.

6. Validation Does the learning programme work? The programme is tested and revisions are made on the basis of information obtained from the validation data until the process does work.

History and development of programming

Although the history of programming is now well known, it is necessary to trace the main developments in this field, in order to focus on the events which led to the present position and on the learning theory on which it is based.

The programmed learning method of instruction has been likened to the dialectic method used by Socrates and also to the tutorial system because of the question and answer technique in a one-to-one relationship of teacher and student. Here the answer to one question is often the basis for new questions and in this way new knowledge is selected and is built on to material which has already been mastered.

The instigation of the programming movement, however, owes much to events in the field of psychological research than to developments in pedagogy.

Pavlov's (1927) work on the conditioning of animals is of interest here. He demonstrated that a hungry dog could be conditioned to salivate at the sound of a bell by first associating food, which caused an instinctive salivation reaction, with a bell and later withdrawing the primary stimulus. A new stimulus could then be associated (paired) with the conditioned (learned) stimulus and so on. Programmers make use of this conditioning when they link new material with something which is already part of the learners repertoire and then withdrawing the familiar stimulus.

Thorndike (1911) contributed to our knowledge of the learning process with his 'Law of Effect' which states that successful actions are more likely to be repeated (learned) than those which are unsuccessful. The reward provided by success or satisfaction is said to reinforce the learner's behaviour. In programming terms the connection between the stimulus (programme) and the response (student behaviour) is strengthened only if some success or satisfaction follows the response.

In the early 1920's Pressey (1926) developed a machine for testing students who had been taught elsewhere. The student had to select an answer from a multiple-choice question. The correct answer to the question was followed by a new question.

Thus the student made an active response which was followed by immediate knowledge of results. Pressey discovered that, as well as facilitating marking, the device also produced a measurable increase in learning. Little interest was shown in the discovery at the time, however.

Skinner provided the current impetus to programmed learning by putting forward proposals based on his experiments with pigeons. Like Thorndike he found that behaviour which is reinforced is more likely to reoccur. He was able to shape the behaviour of animals by reinforcing desired behaviour immediately after it occurred - operant (instrumental) conditioning - and repeating the procedure often enough for the animals to retain the behaviour. By reinforcing at each stage he was able to build up patterns of behaviour.

Skinner (1954) points out the relevance of this experimental work to the modification and control of behaviour in education. He looked into teaching as a whole and put forward proposals based on laboratory experiments. Skinner's solution to the learning situation in the classroom was to write a teaching programme which the student would work through at his own pace. The teaching material would be presented in small steps within the capabilities of all. Each step would require a written response from the student, which would be followed by the desired response.

A correct answer would serve as reinforcement and the material was to be carefully written so that student error would be minimal.

Thus Skinner combined the techniques of shaping student behaviour with that of knowledge of results. His contribution was a learning programme which incorporated the following:-

- (i) instructional material which was presented in small steps - 'frames'
- (ii) each frame to be so constructed as to elicit an active response from the student, followed by
- (iii) the immediate knowledge of results
- (iv) each student to progress at his own rate.

Because each student works through all the frames, in sequence, this method of organizing learning material became known as linear programming.

At about the same time Crowder (1960) was developing an instructional device, which became known as branching (intrinsic) programming. Here larger sections of material are presented to the student than in a linear programme (2 or 3 paragraphs rather than 1 or 2 sentences) followed by a multiple - choice question. If a correct response is selected the student is directed to the next unit of information. An incorrect response results in the student being branched along a subsequence where the nature of the error is explained before a re-test.

A correct response at this stage results in direction back to the main route of the programme.

Skinner's linear programme developed as the result of a knowledge of the learning process obtained from psychological experiments, while Crowder was intent on improving his methods of teaching by improving communication with his engineering students. While differences do obviously exist between the two methods of programming outlined at this stage it is interesting to note that the chief characteristics of Skinner's method listed above are all present in Crowder's scheme as well.

After much controversy as to which is the best method of programming, the present trend is for programmers to use whichever method is the best for the task in hand. The finished product may make use of both techniques.

While accepting the principles underlying the Skinnerian approach to programming, Gilbert (1962) disagreed with the learning laboratory approach to the problem and formulated and developed his own prescription which he called Mathetics.

The mathetic method of programme construction can be applied to any subject but its emphasis on task simulation makes it particularly suitable for teaching skills where 'transfer of training' forms an essential part of the instruction.

One of the basis concepts of mathetics is to start with the most motivating task - this is frequently the last operation which completes the task to be learned. When this step is mastered it is followed by the step immediately preceding it and so on. In some programmes using this method the most difficult sequence is taught first. Few programmes have been written using this method, however.

Computer assisted instruction is the most recent development in this field but it is still in its infancy. Here information is stored in a computer and the machine selects the appropriate sequence for each student according to his performance.

To sum up, programmed learning is a new technology which combines the findings of psychological research with improved methods of testing and new industrial techniques of task analysis and data processing in an attempt to improve efficiency in the classroom.

Chapter 3

RELEVANT LITERATURE

Much research has been reported, both in the United States and in Britain, on a wide variety of topics on programmed learning at the primary, secondary and tertiary levels of education. As a result of the research many early theories have been refuted and the findings have led to rapid changes in programming technique. Particular note is taken here of work carried out with students at the secondary level.

First the selection of a programming method is considered along with the presentation of programmed material. This is followed by a survey of work on frame size, response type, reinforcement and pace. Finally evidence is presented of the effectiveness of the programmed learning method of instruction as compared with other instructional methods.

Linear v. Branching

One of the first problems investigated was whether the linear or branching programming technique was the better. Comparisons were difficult because many different versions of both types are possible for the same subject matter. Research with adults by Roe (1962), with high school students by Stolurow and Berberman (1962) and with secondary modern pupils by Herringshaw and Hunter (1964) showed that the two methods were equally effective.

What appears to be emerging in more recent work is that one type is better than the other under certain conditions rather than in all conditions. Larkin and Leith (1963) found that the linear programme was better than a branching programme with ten year olds on a test of recognition and recall in the below average ability range, while Larkin (1964) found no difference between methods with secondary modern fourteen year old pupils. Leith and Hope (1965) also found that in the lower age level the linear method was better for the less able students. Elley (1966) suggests that the linear method is better for teaching facts and the branching method for concepts.

Conclusions which can be drawn from the research are:-

- (i) linear programmes are good for all ages and are particularly good for teaching memorization and essentially factual material and unfamiliar material.
- (ii) branching programmes are best for a mental age of eleven and over and for teaching conceptual organisation and discrimination.
- (iii) branching programmes almost always take less time to work through.

It is now usual to use both methods in one programme according to the nature of the material to be presented.

Hartley (1964) found that a skip-linear programme, where the able student is able to bypass certain series of frames, was better than a linear programme when teaching twelve year old secondary modern pupils logarithms.

Machine v. Programmed Text

The use of learning programmes presented in a machine is inconvenient because of the cost of the machines, the limited number of programmes available for the machine and the storage space required for the machine. Have machines any advantage which would ~~outweigh~~^{outweigh} this inconvenience?

In eight experiments, using linear-constructed response programmes, reported by Goldstein and Gotkin (1962), no difference was recorded in student learning when comparing the two formats. Four out of five of these experiments showed a significant saving in time when books were used rather than machines. Morris (1965) teaching Latin at the secondary level, Robson and Austwick (1965) teaching algebra to below average ability secondary pupils and Leith and Eastment (1970) teaching probability to secondary modern pupils also found no difference in machine or text presentation. Wallis and Wicks (1964) using a multiple-choice programme reported one of the few findings in favour of the machine groups.

The claim is made that machines, unlike texts, are 'cheat proof' - they prevent the pupils from looking ahead at the confirmation before making a response. However, a number of researches give strong support to the view that looking ahead does not detract from learning. Widlake (1964), Leith (1966^a) and Leith and Ghuman (1967) all conclude that looking ahead makes no difference to the learning which takes place. Thus it appears that it is not necessary to prevent looking ahead. Since it is not necessary to make looking ahead difficult, confirmation of the correct response should be located in as convenient a position as possible.

Claims are also made that the machine enhances motivation. Little evidence is available to support this claim but Leith and Eastment (1970) suggest as a result of their work that with the lower ability groups the machine may assist as an attention-focusing device.

Step size

Programme writing involves the arrangement of the subject matter in small steps but the question is how small? The precise meaning of 'step' is not clearly defined in the literature. It may refer to the amount of teaching material within one frame or to the number of frames per unit of instructions.

Leith (1966b) points out that experiments which compare linear and branching programmes can be used to clarify difficulties with frame size.

Many of these experiments show clearly that material can be taught as effectively with a small number of large frames in the branching method as with a large number of frames in the linear method when maturity of reading and conceptualising ability has developed. Lewis and Gregson (1965) did not find that frame size affected learning from a linear programme.

Early programme writers stressed the need for small steps but teachers and subject specialists have criticised many early programmes because, in their view, teaching steps were too small and too numerous. Able students found these programmes too easy and lost interest. Several studies have been made into the question of the optimum number of frames per unit of instruction. Middleton (1964) prepared a 600 frame programme on spelling and a shorter 400 frame one with fewer frames in each sequence and found that the latter was more efficient. Leith and Burke (1967), repeating Middleton's experiment, found the programmes as efficient.

Morgan and Dubois (1965) found results less good when they reduced the review frames. Couson and Silberman (1960) had better results from the larger number of steps. This work suggests that while some programmes have just enough instructional material others have much redundant material in them. The latter may have too much explanation, practice and review. This poses a problem for the programme writer.

The initial programme drafts should be written with what is judged to be an insufficient or barely sufficient number of frames. During field testing it will become evident where additional assistance must be introduced. If too much material is included at the outset it is difficult to pinpoint redundancies.

Response made

According to Skinner it is necessary for the learner to respond to the stimulus given in each frame for learning to occur and that this response should be overt (written etc.). There have been several attempts to assess the need for the response in the linear programme and to compare the overt (doing) and covert (thinking) response. The evidence for the former is conflicting. Krumboltz (1964) and Buckland (1967) obtained a no difference result when comparing a written response programme with the same programme which had the response material included in the frames, both for immediate scores and at the retention stage. Goldbeck and Campbell (1962) found the reading group better at the retention stage while Krumboltz and Weisman (1962) found the written response group better at the retention stage.

Overt responses are helpful to the programmer when validating his programme but frequent overt responses reduce the rate of learning and may prove irksome, especially to the able student. Are they in fact essential?

There is evidence to suggest that overt responses are necessary when new material is being learned and for discrimination, while in the assimilation of concepts, classifying, contrasting and learning examples overt responses are not necessary and may even prove distracting.

Thus Leith and Burke (1967) found overt responding best for spelling with an 'A' stream secondary modern group - a task requiring little internal organisation. Leith and Eastment (1970) reported that overt responding was not superior for pupils with above average ability for a programme requiring conceptual learning. Leith and Ghuman (1967) found that the covert response was best when teaching co-ordinate geometry to sixteen year old pupils in a grammar school but the overt response was superior at thirteen years - perhaps as an attention holding device.

Re-inforcement

In Skinner's (1954) view the correct answer to each frame serves as reinforcement for the student and for this reason he suggested that the programme should be carefully written so that student error would be minimal. Experimental work has shown that positive re-inforcement is usually most successful but negative re-inforcement may be more effective than no re-inforcement at all.

Elley (1966) showed that avoiding errors was helpful to rote learning. Elley (1966) and Leith and Wisdom (1967) found no relationship between the number of errors and test performance. Leith and Clarke (1967) suggest that making and overcoming errors may sometimes help in learning.

Frequent re-inforcement may not be necessary. Three degrees of re-inforcement were provided by modifying the number of confirming answers by Berglund (1969) with a fourteen year old group. No statistical difference between the varying amounts of re-inforcement provided was obtained. It is possible that the more able or more highly motivated learners may need less re-inforcement than those of lower intelligence or those who are not interested.

Teaching method

Duncan and Hartley (1969) taught and tested under a variety of verbal and visual modes. The subjects who were asked to produce a maze in the form that they had studied it found the task significantly easier ($p < 0.001$) than did subjects who had to translate it into another form. This work suggests that programme writing should take account of the form of the criterion test as well as the content of the teaching objective during programme construction.

Own Pace

Initially programmers stressed the virtues of individual instruction and the speed of working programmed material varied widely. A number of studies have shown that this is not essential to learning and in fact paced work or group work can be beneficial. Austwick (1964) and Sawirig (1966) showed that pairs and groups working together could be as efficient. Moore (1967) reports a series of experiments with similar results. Kay et al (1968a) and Hope (1969) found that paced individuals worked quicker than they would have done at their own pace with the same results. Hartley (1968) concluded that there are conditions where learning under conditions of self-pacing may be less efficient than working with others and/or under some form of external pacing.

Programme v. Teacher

Immediate gains Convincing evidence that programmed instruction is effective for teaching has accumulated over the last decade. Kay (1968b) points out that in each experiment the programme or the teacher may be a particularly good example and thereby invalidate findings. He suggests, however, that the consideration of a large number of these experiments will overcome this chance element to some extent.

Hartley (1966) listed the results of the 112 studies (82 of these are American) comparing teachers and programmed instruction as shown in Table 3.1

Table 3.1 The Results of 112 Studies comparing Programmed with Conventional Instruction

Measure recorded	Number of studies	Programmed Instruction Group		
		significantly superior	not sign. different	sign. worse
Time taken	90	47	37	6
Test results	110	41	54	15
Re-test results	33	6	24	3

The results of experiments carried out in schools only are set out in Table 3.2

Table 3.2 Results of Comparative Studies carried out in Schools.

Measure recorded	Number of studies	Programmed Instruction Group		
		significantly superior	not sign. different	sign. worse
Time taken	37	13	23	1
Test results	49	16	22	11
Re-test results	19	1	17	1

More recent studies carried out by Daniel and Murdock (1968) and Leytham (1970) found in favour of programming. The conclusion would appear to be that programmed learning can teach as effectively or more effectively than the traditional lesson and in a shorter time.

In a similar comparative experiment Pikas (1967) found that the similarity between the test and the learning task was the decisive variable in performance differences. Roebuck (1970) found that programmed learning was superior to conventional instruction. He suggested, however, that the methods taught along significantly different lines and emphasised different concepts so that any observed differences in attainment were a function of the testing procedures used. The criterion test in his study was compiled by reference to the learning programme and the programmers test therefore was specifically set on this work. These studies illustrate the importance of the necessity for great care in test construction so that one method does not have an advantage over the other on this score.

Retention Tables 3.1 and 3.2 show that retention has also been studied in a number of cases and that usually the result has been one of no significant difference. Orr (1968) tested retention and reported no difference between the programme and the conventional lecture method of presentation after one day, one week and two weeks. Leytham (1970) found no difference after six months.

Course integration

Little work has been done on the use of programmed sections in a course rather than programming the whole course. A study on programme integration was carried out in the navy by Wallis et al (1966). Students taught by integrated procedures were far superior to those having conventional classroom instruction and these in turn superior to those taught by the programmed method without supervision.

In view of the literature it was decided to develop a linear programme. This programming method is suitable for all ages and appears particularly good for teaching essentially factual and unfamiliar material. The evidence suggests that overt responses will be most suitable for the new material to be learned and for the age group involved.

A programmed text is chosen for the method of presentation because it appears to be as efficient as machine presentation and the cost is less. Pupils will work individually but will be externally paced at the rate of one programme section per teaching period.

Chapter 4

PROGRAMME CONSTRUCTION I - ANALYSIS

The writing of a learning programme involves a number of specific tasks which can be conveniently grouped into the analysis of the instructional material; the synthesis of this material into a learning programme and programme development. The various procedures carried out in the construction of this programme have been grouped in this way and are set out in Table 4.1

Table 4.1Stages in Programme Development

I ANALYSIS	1. Preparation of Objectives and programme specification. 2. Preparation of Criterion Test. 3. Definition of pre-requisite knowledge and skills. 4. Selection of Teaching Points and Task Analysis.
II SYNTHESIS	5. Sequencing Instruction Material. 6. Writing the Frames 7. Frame Sequence Evaluation and Editing.
III DEVELOPMENTAL STAGE	8. Validation - an assessment of the learning programme based on student performance and subsequent revision until an acceptable level of attainment is reached.

At the outset a programme writing task analysis, Fig 4.1, was compiled which identifies, in sequence, the major tasks to be carried out. Various check and decision making points are indicated en route.

Figure 4.1 Programme Construction Task Analysis.

(After Callender 1969)

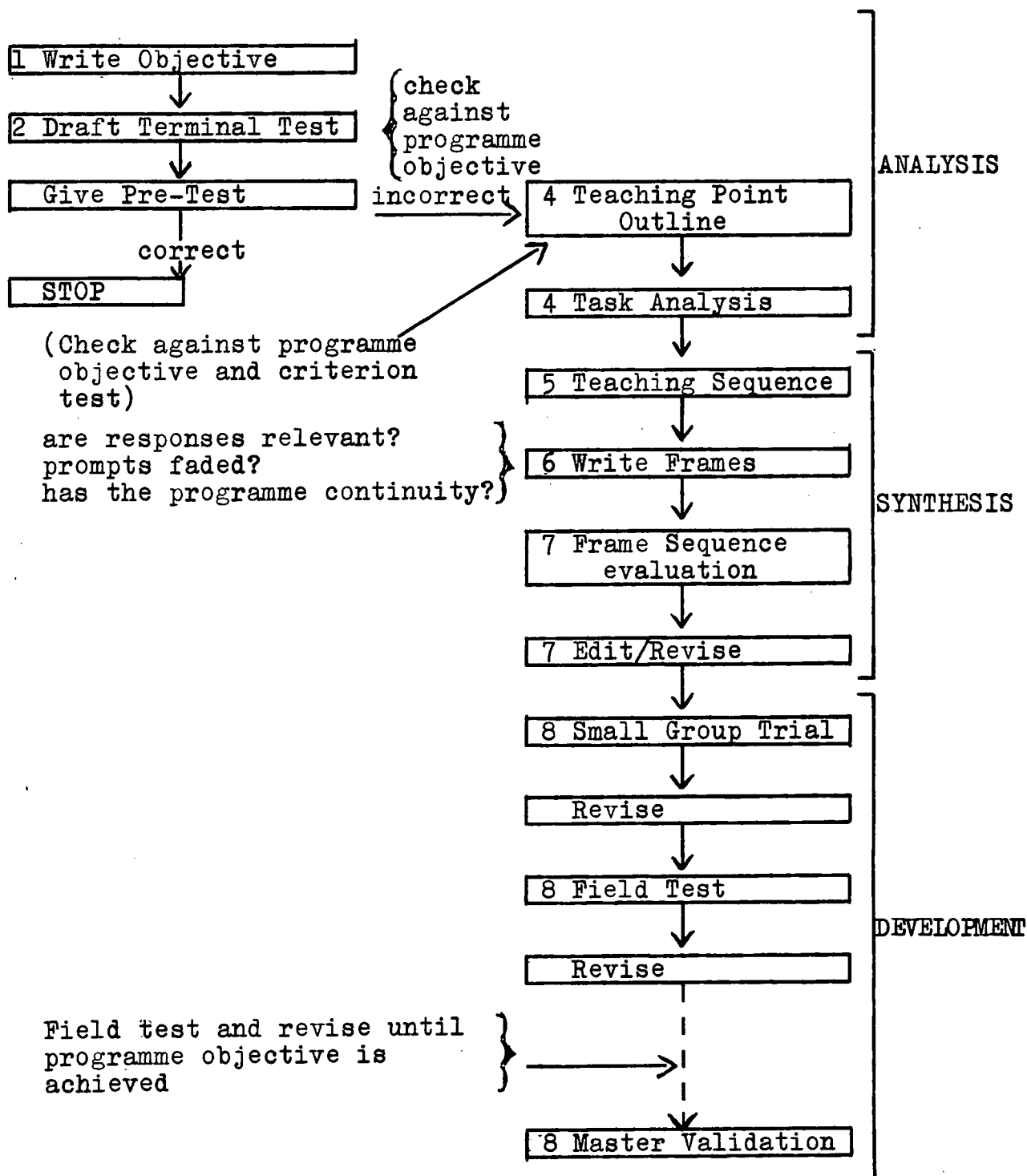

This chapter is, however, primarily concerned with the first group of procedures - the analysis of the instructional material.

What to programme?

The choice of programme material depends upon a number of factors relating to the programmer, the student, the stability of content material, time and cost and upon the availability of other programmes or resources.

Whalley (1966) and Kay et al. (1968a) point out that the programme writer should be familiar with (a) subject content (b) pupil age and ability (c) teaching techniques (d) programming techniques and Leedham and Unwin (1965) suggest that a learning programme at secondary level is better attempted by a subject specialist, who has teaching experience at that level, than by the psychologist or don,

As the researcher is a geography specialist, teaching in a Senior (13-18) High School, it is appropriate that the learning programme to be developed should be on a topic in this subject at the secondary level. The various stages of programme validation and the evaluation experiment planned necessitate the availability of a fairly large number of pupils. For this reason the 13 - 14 age group was chosen as the target population because it is the only age group in the school where all pupils study geography. The age and type of student will determine not only the content and difficulties of the concepts introduced but also the programming style.

It is now more normal to programme relatively small sections of the syllabus rather than the whole course and the learning programme should fit into the course in a planned way. The modern approach is to consider the whole syllabus and select the subject areas which would benefit most from the programmed learning method. Physical geography is included in the school syllabus for the first year¹ in the summer term and within this area of study glaciation was chosen as a possibility.

The topic required for this study needs to be long enough to provide useful data for programme validation and evaluation. It must, however, be neither too time consuming for the pupils as to adversely affect the classes involved nor for the researcher. A unit of the course, such as glaciation, would normally have a time allocation of 5 - 6 teaching periods. The estimated time requirement for the learning programme was also 5 - 6 periods but the time required in the validation and evaluation groups would be 9 - 10 periods. The reason for this is that it is necessary here to introduce the programming method, to explain the nature of the experiment and to allow time for the various pre-tests, post-tests, retention tests, questionnaire and general intelligence tests.

¹ this is the third year (13 - 14 year olds) at secondary level. The pupils concerned transferred to this school from Junior High Schools at 13+.

Writing a learning programme is a time consuming business and the probable usefulness of the finished product must be considered at the outset. Will the demand justify the time and expense incurred in programme production? Is there a suitable programme which has already been developed? Is there a better method or more economical method of teaching the same subject matter?

The suggested topic of glaciation lends itself to the programming method because of the inherent internal logic of the subject matter. The content material is also suitable because it is unlikely to change over a number of years. The large numbers of pupils studying geography at 'O' Level would justify the time and expense incurred. When this study was being planned only part of the proposed programme content was available in programme form¹. This was however, unsuitable for third form pupils because it had been developed for use with 16+ 'O' Level students. This material also falls into Espich and William's (1967) category of 'pseudo-programmes' because no validation data has been produced. The final question regarding the best method is difficult to answer but the results of this study may go some way to provide a solution.

1 G. Hitchin Glaciers Wiltshire 1965.

1. Developing the Programme Objective

The content of the learning programme was built up by reference to source material, the curriculum, the examination syllabus, established texts and also by discussions with specialist teachers. Eikeboom (1969), however, warns against relying solely on traditional sources. Learning psychology can be of value both in selection of material and in the method of presenting it. Observations of learning behaviour and attitudes while teaching similar groups also provide useful information for the programme writer.

The 'O' Level requirements on this subject must be considered at this stage. The relevant sections of the G.C.E. Joint Matriculation Board 'O' Level Syllabus² for 1971 are set out below.

'The examiner may set questions on any part of the syllabus which involve the interpretation of photographs.

1. Elements of World GeographyLandforms.
3. Map reading. The elements of map reading as illustrated in Ordnance Survey maps'.

The syllabus gives little indication of the scope and depth of study required by the examiner but some indication of this can be obtained by a study of recent examination papers. The questions which refer to some aspect of glaciation in this examination, since 1963, are presented in Appendix (i). From these it will be noted that no question on map interpretation has been given during this period.

² J. M. B. (1969) General Certificate of Education Regulations and Syllabuses 1971 page 23.

It is evident from these questions that the examiner requires the various glacial features to be described, their formation explained and an example given. Illustrations are to be drawn where appropriate. This evidence has governed to some extent the range and depth of content in the learning programme.

A study of all sources referred to above provide the programme content but an instructional objective must take the form of stating specifically what the pupil must do, in measurable goals, at the completion of the programme, in order to demonstrate that he has achieved the instructional objective. A programme objective describe an intended outcome rather than a description or summary of content. It is a statement of the desired terminal behaviour. It must be specific and precise. Mager (1962) suggests that the programmer will have a clear picture of his intent in mind and will be able to communicate this to his students if he (i) identifies the terminal behaviour by name (ii) describes important conditions under which the behaviour will be expected to occur (iii) describes how well the learner must have mastered the subject.

Pipe (1966) considers that defining the programme objective is the most critical step in programme production. This precise statement of intent is of use to the programmer in focusing attention on the specific goal while writing the programme and as a criterion against which to measure success in the developmental stage of programme production.

By setting out clearly what in fact the programme teaches the programme objective provides the teacher with essential information when considering its inclusion in a scheme of work. It can also be of use to the pupils as a conspectus of the work to be studied.

The final version of the teaching objective of this programme is set out below. It has been modified and refined as programme construction progressed.

Learning Programme Teaching Objective

The pupil, by written test, shall display a knowledge of the following:-

i) Ice sheets and glaciers.

The terms ice sheet, nunatak, iceberg, snowfield, snowline, corrie, glacier, avalanche:- each to be described and given a location where appropriate.

Movement of the glacier and ice within it.

Terms: crevasse with causes, sérac, icefall.

Moraine and terms lateral, medial and terminal moraine.

Illustrated description and explanation of a moraine-dammed lake with example.

ii) In the highlands of Britain, glaciers eroded the surface. The formation of the resulting features; corries, arêtes and U-shaped valleys with their hanging valleys, waterfalls and ribbon lakes to be described. Corries, arêtes and U-shaped valleys illustrated.

One example of a corrie, an arête, a U-shaped valley and ribbon lake given.

- iii) Identification of glacial features listed, as presented on a 1" Ordnance Survey map of a highland area:- arête, corrie, U-shaped valley, hanging valley, ribbon lake.
- iv) During the Ice Age deposition occurred in the lowlands. Depositional features include boulder clay, drumlins, erratics and eskers. Each feature to be described, explained and an example given.

Preliminary Programme Specification

At this point it is necessary to specify the type of pupil for which the programme is intended and the setting in which it will be used. A statement must also be made of what the criterion performance of the learning programme is to be.

Target population - first year pupils in a Senior High School where entrance is at 13+ as a result of guided parental choice. Above average intelligence.

English speaking.

G.C.E. 'O' Level in view.

Restraints The programme to be designed for use in the school situation.

Tolerance A Gain Ratio¹ of over 1.2. This is a measure of the learning which occurs as a direct result of studying the learning programme.

¹ discussed in more detail on page 74.

2. Criterion Test

At this point a criterion test is constructed. This test is completed by the pupils after studying the learning programme. The test affords evidence of the success of the programme in achieving its goals. A perfect programme would provide 100% success for all pupils. However, in practice the programme is revised until it achieves an acceptable level of success, in this case a Gain Ratio of more than 1.2. ^{The} test is also given as a pre-test to permit an analysis of learning gains. If a very high proportion of the questions are answered correctly at the pre-test stage study of the programme by the pupils is unnecessary.

Particular care must be taken with test construction because a major part of programme validation is carried out on evidence supplied by answers to the test. The test must be written in clear and unambiguous terms.

The criterion test covers items of factual knowledge, of comprehension of principles and of ability to deduce from principles. It is objective in nature (Brown 1966). There are a relatively large number of items which can be accurately marked. Each item in the test covers a specific point in the programme objective so that no overlapping occurs. The large number of short questions permit the whole learning programme content to be tested. Many of the questions are of the open-ended variety requiring short answers often of one word. These test items ask a single, precise question to which there is a single correct answer.

Other questions require a definition or short description. In this investigation these questions can be accurately marked because only one specialist teacher is involved in testing. The test construction permits rapid accurate marking.

Any test used as a criterion for programme validation must be valid and reliable. A test is 'valid' when it measures accurately the specific ability it purports to measure. In practice it is assumed that a subject test for school use which is carefully constructed on a detailed test schedule is inherently valid for that specific purpose, (Brown 1966). This is called content validity. Content validity is especially important in achievement testing. The criterion test in question has this content validity because it was carefully constructed on a detailed learning programme objective which not only identifies the subject matter but also the behavioural outcome to be measured.

One of the characteristics of a good measuring instrument is that it should give the same measurement of the same thing on different occasions. If it does it is reliable. (Examinations Bulletin No.3 1964). A reliability coefficient of 0.79 indicating the stability of the test scores is recorded. It was calculated on a test-retest¹ over a one month interval in the final programme validation.

11 Using post-test and retention test scores (Appendix xi).

The criterion test also underwent amendments in the course of programme development. At first two parallel tests were used as a pre-test and post-test. In the final validation the same test was used as a pre-test, post-test and retention test so that knowledge gains could be more accurately ascertained. This test with answers and mark scheme are presented in Appendix (ii). ~~using post-test and retention test scores (Appendix xi).~~

3. Define the Pre-requisite Knowledge and Skills.

This learning programme is written for pupils of above average intelligence¹ who live mainly in an urban industrial environment and have been educated in the English school system. Because of the researcher's teaching experience with pupils of this type it was possible to make reasonable assumptions about pupil interests, reading ability and possible attainment.

It is assumed that the pupils will have little knowledge of glaciation. However, in order to follow instructions and carry out interpretations the pupil will need to understand direction, four figure Ordnance Survey map references and the concept of contours. Because of the varied educational experience of the pupils before entry to the school at 13+ it is not known whether this knowledge exists. For this reason three additional questions² were included in the pre-test to establish the position.

1 Field Test 2 pupils had a mean General Intelligence score of 85.63 - A~~H~~ 4 Group Test of General Intelligence.

2 Appendix (ii) Questions 1, 2 and 3 in Test 4.

4. Teaching Point and Task Analysis.

Espich and Williams (1967) classify each piece of knowledge according to the necessary student involvement. They recognise (i) An exposure level - enrichment material requiring no retention. (ii) A recognition level requiring broad discriminations only. (iii) A recall level where the pupil is able to define a term in his own words. (iv) A memory level - repeat verbatim. (v) A concept level - here fine discriminations and the ability to generalize are required. Basically this involves the application of knowledge.

A recognition of the level of learning required for each objective facilitates programming. Exposure level and recognition level learning will require less attention in terms of instructional frames and practice frames than recall, memory and conceptual learning.

Table 4.2 is a comprehensive list of the teaching point and task requirements necessary to satisfy the instructional objective of the programme.

Table 4.2 Teaching Point and Task Analysis

Teaching point	Define/ describe	Explain	Example/ location	Diagram	Identify on O.S. map
ice sheet	✓		✓		
nunatak	✓				
iceberg	✓	✓	✓		
snowfield	✓		✓		
snowline	✓				
corrie	✓				
glacier	✓		✓		
avalanche	✓		✓		
movement of ice	✓	✓			
crevasse	✓	✓			
sérac	✓				
icefall	✓				
moraine	✓	✓			
lateral	✓				
medial	✓				
terminal	✓				
moraine-dammed lake	✓	✓	✓	✓	
glaciers erode highlands	✓	✓	✓		
corries	✓	✓	✓	✓	✓
arêtes	✓	✓	✓	✓	✓
U-shaped valleys	✓	✓	✓	✓	✓
hanging valleys	✓	✓			✓
waterfalls	✓	✓			
ribbon lakes	✓	✓	✓		✓
Ice Age	✓				
glaciers deposit in lowlands	✓				
boulder clay	✓	✓	✓		
drumlins	✓	✓	✓		
erratics	✓	✓	✓		
eskers	✓	✓	✓		

Which programming method?

Now that the instructional material has been analysed a decision can be made upon which of the available programming methods will be best suited to the instructional task. The selection is made on the basis of the programme objectives and the learners. The characteristics and properties of the available programming techniques are reviewed at this point.

Linear programming Instructional material is presented in small steps called frames. Every student pursues a straight course through the programme, responding to each frame and has the response immediately confirmed before proceeding to the next step. Responses are normally constructed and the frame so worded that the student will achieve a high success rate, say 90% - 95%, on frame response. The linear programme can be produced in book or teaching machine format.

Frame 1

Frame 1

Response 1

2	Answer 1

	Frame 2

	Response 2

3	Answer 2

	Frame 3

	Response 3

This programming method is effective for all age and ability levels. It is particularly good for adolescent learners because the technique is relatively simple and there is a high level of response and reinforcement. Detailed information, new terminology or previously unknown topics, factual material, drawing diagrams or building up concepts are suited to this method. If the learners are evenly matched a linear programme may handle all students successfully. If individual ability is highly variable modifications can be introduced.

Skip-linear programming If a wide learner ability range exists some pupils will require more practice and review items than others. This difficulty may be overcome by introducing skip sequences at appropriate points into the linear programme. Here students can be directed to skip a sequence of frames after giving a correct response to a key 'test' frame. An incorrect answer results in the normal sequence being followed in order to obtain further information and practice.

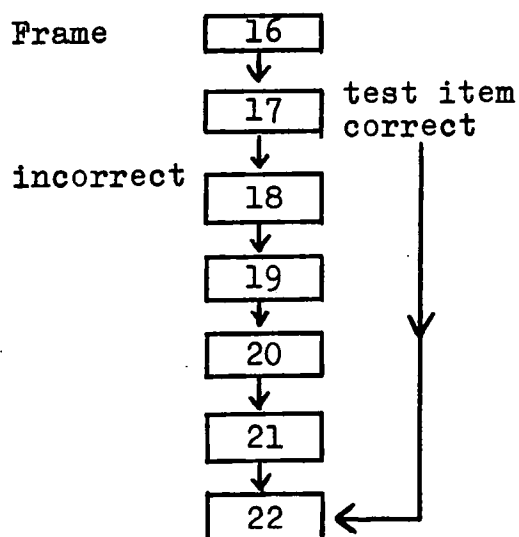

Linear with branching sequence Alternatively

a high error rate at a particular point can be overcome by directing these students along a sub-sequence of frames designed to correct the particular error made.

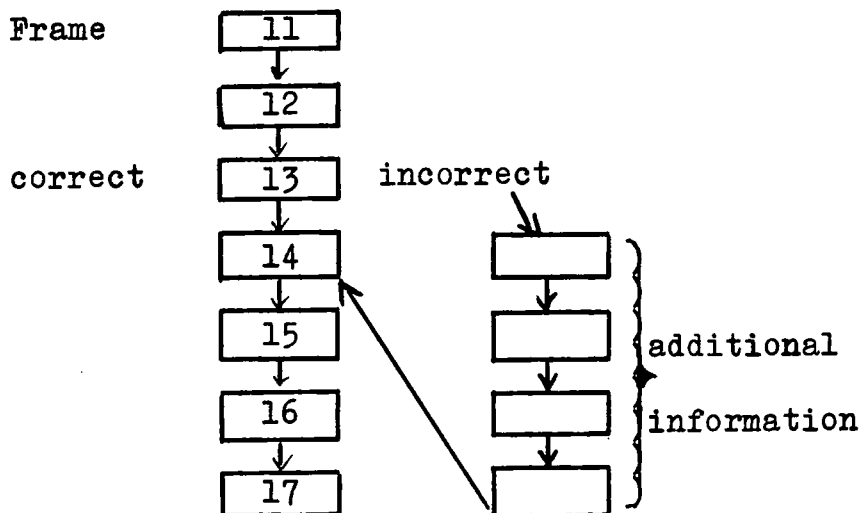

Branching or Intrinsic programming The frame

size and the teaching material included in it are much larger than in a linear programme. The teaching material is followed by a multiple-choice question. One of the choices is correct and is followed by the next frame along the main stream of the programme. An incorrect choice results in a detour designed to explain mistakes, and give additional information or practice before a re-test. The branching programme is designed, through interaction with the student, to present him with adaptive tutorial instruction based on his own responses. Branching programmes can be produced in scrambled textbook or teaching machine format.

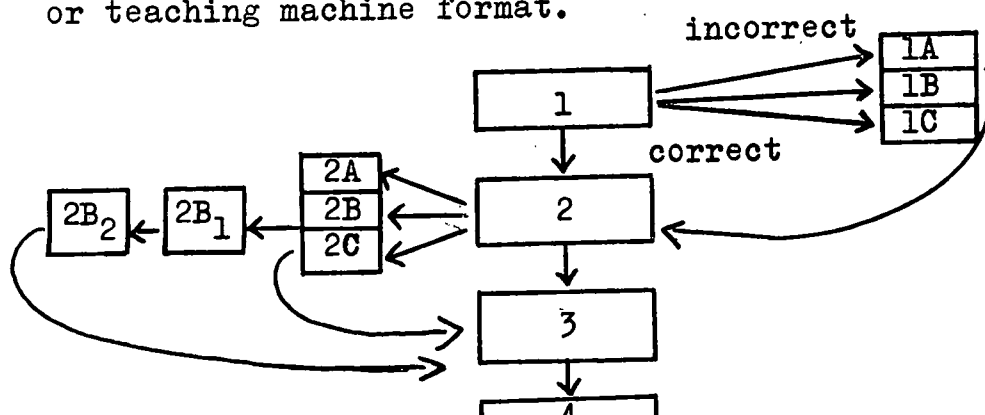

Branching programmes are good for teaching concepts for which a background already exists or for topics on which several opinions exist or need to be explored. They are also suitable for recognition knowledge and for comparisons between topics. This programming technique is best with students who have a mental age of over 11. It can be written on a style which demands less overt response.

In recent years programmers have tended to adhere less rigidly to one type of programme presentation and now programmes are being produced which employ both linear and branching methods in one programme. Rowntree (1969) calls for a mixture of methods in what he terms 'tutorial programming' viz. the use of the programming style best suited to the instructional objective. This greater variety should reduce problems of boredom.

It appears that linear and branching methods of programming are within the scope of most teachers after a relatively short period of instruction. Mathematics and computer assisted programming, however, require a lengthy and specialized training and can only be undertaken by specialists in programming.

After taking into account the student age and ability and the content of the proposed learning programme it appears that the linear style of programming will be most appropriate for this investigation.

The linear programme is particularly good for the adolescent student with its relatively high level of response and reinforcement. The linear programming technique is best suited to the content material. This material is new to the students, is detailed and factual and requires the use of sketches and diagrams to facilitate concept development. If the need becomes apparent, in the developmental stage, skip sequences or a limited number of branches can be introduced into the linear programme sequence.

It is intended to use constructed responses in the programme because of student age and because of the nature of the criterion test which requires written verbal and diagrammatic answers. It is, however, evident from research that covert responses (think answers) can be as effective in some cases and they add to a variety of style. The disadvantage of covert responses to the programme writer is that there is less evidence on which to base programme improvements.

Which media?

Most programmes begin on paper but can be transferred in part or total to film, television or tape. This can occur only if facilities are available to the programmeer for production and also to the student who is to use the programmed material. The majority of programmes in use are of the pencil and paper variety. This is the medium chosen for this learning programme.

Book or Machine?

Programmes produced in book form are low in cost and are adaptable to a number of programming techniques. Machines may be motivational at the secondary level and are 'cheat proof', that is the learner must respond before checking his response. Research, however, suggests that seeing the answer first does not affect the learning which takes place. Machines are costly and much more bulky thus requiring considerable storage space. The programme itself is much more durable if on film. From the cost angle it is necessary to use the book variety here but the evidence suggests that this is not a disadvantage.

Chapter 5

PROGRAMME CONSTRUCTION II - SYNTHESIS

Now that the proposed programme material has been analysed the task is to construct the learning programme. At first a planned sequence is considered, followed by the writing of individual frames. A preliminary check on the purpose and arrangement of the frames and also programme layout follows before the embryo programme is ready for initial testing by the student.

5. Sequencing Instructional Material Espich and Williams (1967) point out that a programme must have a methodical line of development as well as continuity and cohesion. Several methods ranging from the strictly logical method of the RULEG system to pragmatic methods have been suggested for the ordering or sequencing of learning programme content. They all, however, agree that it is essential to have a detailed analysis of the programme objectives and the instructional material necessary to obtain these objectives as a starting point. A summary is given of some of these methods before that used in the construction of this programme is outlined.

The ruleg system (Evans, Glaser and Homme 1960) was one of the earliest attempts to formalize the production of frames and their sequencing. In this system the subject matter is classified into rules (RU's) and examples (EG's). A logical sequence of the rules is entered on a RU-matrix - a graphic representation of the relationships between all the rules included in the goal.

The frames are then written. This system is complex and assumes that the material to be programmed consists of rules and examples. Ruleg programmers find the method particularly good for maths and science topics.

In Mechner's system (1961) the programme topic is divided into between five and twenty sections which are entered on red index cards. The material entered on each of these is sub-divided and entered on yellow cards. The next sub-division is entered on green cards and the final one, which consists of basic concepts, on blue cards. Each blue card provides the material for from five to ten frames. These items are then entered on a flow chart to facilitate the arrangement of the subject matter units.

Gilbert (1962) devised a complex system called mathetics for organising and sequencing a learning programme. This method applies systematically the principle of reinforcement theory to the analysis and reconstruction of learning material. One of the basis concepts of mathetics is to start with the most motivating task. With serial tasks this is likely to be the last operation which completes the process. The entire chain of operations is displayed to the learner who then completes the last task in the chain, followed by that which immediately precedes it and so on. With non-serial sequences the most difficult sequence is often taught first. The method is thus designed to provide the greatest re-inforcement.

Many writers have followed a much more pragmatic approach to programme writing. An essentially subjective approach is advocated by Skinner (1954), Holland (1960), Klaus (1960), Markéle (1964), Pipe (1966), Callender (1969) and others.

There is general agreement on the need for a specific and detailed outline of the programme objectives and the establishment of the criterion behaviour before actual writing of the programme ~~behaviour~~ begins. The programmer then has in mind the specific responses the student is intended to possess, after completing the programme, together with the context in which these responses are to be made.

Skinner (1958) suggests that the use of textbooks and expert advice should come late in programme development because he fears the influence of the traditional presentation of the material. Other programmers, the author included, prefer a wide consultation of varied source material at the outset.

The synthesis of the various concepts into a viable teaching sequence can not be laid down but must take into account the instructional material, pupil ability, pre-knowledge and motivation.

Sequencing in this programme The estimated time requirement for the programme in question was five teaching periods. A preliminary survey of the instructional material resulted in the decision to subdivide the work into five units called sections, which follow the natural subdivisions of the material, each to

be worked during one teaching period of 35 - 40 minutes. Various solutions were studied before the section order and content were finalised. This is listed in Table 5.1.

Table 5.1 Sectional Content of the Learning Programme

Section 1	Ice Sheets and Glaciers
Section 2	Glaciers
Section 3	Glacial Features in Mountainous Areas
Section 4	Glacial Features on an O.S. map
Section 5	Glacial Features in a Lowland Area

The material in sections 1 - 4 is concerned mainly with glaciers and glacial erosion in highland areas while section 5 concerns glacial deposition in lowland areas. The pupils were considered to be more familiar with the material in section 1; therefore the aim was to revise and increase knowledge in this area and to use this platform to extend the pupils' experience. Section 2 is concerned with the processes of erosion before considering the relief forms resulting from this erosion in section 3. Map interpretation of these relief forms follows closely in section 4. Concepts included in section 5 are perhaps of less significance and are also completely new to most pupils.

This discussion illustrates the point that a knowledge of the ability, pre-knowledge and motivation of the pupils as well as of learning theory and teaching techniques assists in the sequencing of learning material. This knowledge also facilitates sequencing material within each of the sections.

Table 5.2 gives the order in which the concepts are presented in each section in the programme. Care is taken at this stage to see that the plan fits the programme objective with precision, non relevant material is deleted.

Table 5.2 Teaching Point Arrangement within Programme

Sections

Section 1

ice sheet + example

nunatak

iceberg

snowfield

snowline

corries

avalanche

glacier

Section 3

ice erodes in highlands

corrie + example

arête + example

U-shaped valley + example

hanging valley

waterfalls

ribbon lake + example

Section 2

example of valley glacier

movement of ice

crevasse with causes

sérac

icefall

moraine + kinds

moraine-dammed lake + example

Section 4

recognition of the following

features on O.S. maps:-

corries

arêtes

U-shaped valleys

ribbon lakes

hanging valleys

waterfalls

Section 5

Ice Ages

deposition in lowland areas

boulder clay

drumlins

erratics

eskers

In this programme the nature of the instructional material frequently permits the exploitation of subject logic as a theme for the sequence. For instance, in section 1 the iceberg follows from a knowledge of movement in the ice sheet, in section 2 the knowledge of a terminal moraine helps to explain the moraine-dammed lake and a sérac follows from an understanding of a crevasse. If the material can be arranged in an interesting or compelling way it will have more chance of success. For this reason a developmental order which proceeds from the known to the unknown or from the simple to the complex is preferred in some instances.

Several modifications were made to the original plan as a result of field testing before arriving at the final prescription as set out above. Thus the development of the instructional sequence involves practical experience and empirical testing as well as some knowledge of learning theory.

6. Writing the Frame

For reasons already stated a linear constructed response mode has been selected as the type most appropriate for this programme. It is planned to arrange the teaching frames in vertical sequence for ease of assembly and the accommodation of diagrams.

A linear programme requires the student to work through the sections of the programme in sequence and also refers him to additional information from time to time.

The frame is the basic unit of a learning programme. It is usually fairly short and consists of three parts: (i) some basic information which is presented to the student (ii) the student is required to make at least one response (iii) he checks his response against the desired response. The correct response is given at the beginning of the next frame. An illustration of a typical frame layout taken from section 1 of the programme is given in Figure 5.1. The complete learning programme in its final form appears in Appendix (iii).

Fig. 5.1 The three Components of a Frame

Frame

15

Because the temperature decreases as you ascend (go up) a mountain, permanent snow will be found at the _____ of many mountains.

16

top

If the mountain is _____ enough permanent snow will be present, even near the Equator.

high

Any additional information which is required for pupil reference such as longer passages of text, maps of atlases, sketches or diagrams, data or photographs is presented separately as a panel. The frame refers the pupil to the relevant panel for study at appropriate points. A number of panels are included in the learning programme.

The rationale of a constructed response programme is that the pupil learns the response that he makes; therefore it is important that the response that he is required to make is something which is to be learnt. It is also helpful that he should respond correctly so that he will not be discouraged by frequent failure. A frame response error rate of less than 5% for key frames¹ and less than 10% overall is the general aim but a strict adherence to this is not entirely appropriate. Taber et al. (1965) warn(s) against being over-cautious about student error rate and a number of programmers hold the view that some student errors are not entirely undesirable. Thus an incorrect answer may occasionally be used by the programmer to point out general misconceptions or to focus attention on details. If the student is occasionally allowed to guess the answer before a teaching sequence or to express an opinion his interest may be aroused.

Generally speaking, however, the programmer aims for a low error rate and several means are used to ensure this.

1 A test frame within the programme which follows a teaching sequence.

The material must be presented in an unambiguous way and with an attractive layout. The steps must be challenging but not too large for the target population. It is usual for only one concept to be understood or one fact to be learned to be introduced at a time. The programmer also uses various cues or prompts to guide the student to the ultimate programme objective. As the student becomes more familiar with the new material the prompts are progressively withdrawn or faded until they are finally removed.

Prompting A number of prompting techniques are used by the programmer in the instructional part of the frame in order to guide the learner to a new behaviour pattern. These prompts may be grouped in two broad divisions, each having different functions in controlling student behaviour. They are formal prompts and thematic prompts.

The formal prompt gives the student information about the structure of the response he is to make. Examples of this type taken from the programme are those which indicate by a response blank the number of words required or give initial letters or introduce a restriction with the use of 'a' or 'an' or indicate possible alternatives. Emphasis prompts such as those which underline a key word or use capitals are included in this group.

The thematic prompt operates as a cue because of its theme or meaning and includes all cases where guidance comes from the context. This type is used most frequently. In this study the cue makes use of both verbal and visual stimuli. The prompt may communicate correct ideas in the form of stated rules or examples or in the logical development of a theme or sequence of an argument. The similarity of ideas or contrasts also has its place.

If the prompt is given in the previous frame it is often referred to as a temporal or sequence prompt. A copy prompt requires the student to copy given information only. As it is of dubious worth, however, it is used only sparingly.

The Response A written response mode is used in the programme. The written response made by the pupil at each stage is to be entered on a prepared answer sheet.

In programme construction the response required from the student should be as close as possible to the required behaviour. It follows that the frame responses called for should include all types used in the criterion test. Also a variety of response type should be included to add interest and thus assist in student motivation.

A summary of response types used in the programme follows and actual examples used are indicated.

- (i) The missing word (or words) is indicated by a blank space as in frame 14 section 1.
- (ii) Binary choice - here one of the two answers given must be chosen as the correct answer; for example, bigger/smaller in frame 22 section 3, more/less in frame 2 section 5 and warmer/colder in frame 3 section 5.
- (iii) The student is required to find the answer to a straight question. The answer is normally one word. The information is given in the frame or a panel and the student has to select the answer or solve a problem using the information. Frame 6 section 1 and frame 5 section 2 illustrate this type.
- (iv) Open-ended questions are used occasionally as in frame 9 section 1 where the request is 'describe it in your own words'.
- (v) Diagrams, photographs and maps are used extensively and a variety of response modes is employed here. A diagram has to be completed in frame 30 section 2; a feature labelled in frame 27 section 2; features on a diagram identified from a multiple-choice list in frame 25 section 3. In frame 7 section 4 the student is required to draw a contour map from a description. Using an O.S. map the student measures distance in frame 13 section 4, counts tributaries in frame 15 section 4 and identifies glacial features in frame 10 section 4.

Fading or Vanishing The programmer uses prompts in order to guide student behaviour at the beginning of a teaching sequence. As the sequence proceeds the student is given less and less help - the prompts are faded - until, finally, the student responds correctly without any help in a test frame which contains no prompt.

Types of Frames Different kinds of frame sequences are required in order to modify behaviour in different respects. Within the programme section a number of frame types are used, each having a different function. The learning programme section begins with an introductory frame or frames followed by a number of frames dealing with each teaching point and closes with a review or summary of the work covered in the section.

The sequence of frames used to teach one concept can be subdivided into (i) a teaching component, (ii) a practice component and (iii) a test component. Teaching frames present the learner with new information in a logical sequence. These frames are based on the teaching point outline. The frames contain a prompt in order to ensure maximum possible success. Then the student should be given practice in order to reinforce the desired behaviour and this practice should vary in form and content. During practice the strength of the prompt is gradually faded. At the end of each teaching sequence there should be criterion or key frames which test the learner on the concept taught. The test frame must contain no prompt.

Each programme section begins with an introductory sequence. The student may be asked to respond to some behaviour with which he is familiar and then teaching begins from this base. The frames may recall material known by the student or revise work in previous sections.

Review sequences repeat essential elements of previous learned material or summarise the work in progress. These frames may be interspersed in the section. After several related points have been taught a frame may be used to review and test all the concepts together.

Linking the Teaching Points. Each section of the learning programme contains a number of teaching points which must be linked in some way so that the programme has unity. Becker (1964) outlines a number of techniques which can be used to relate teaching points in order to produce an integrated programme.

Chaining - the response to one stimulus is used as part of the next stimulus.

Dovetailing - the new teaching point is introduced before the completion of the present teaching point sequence.

Webbing - teaching points are linked together through common stimuli or common responses. In this way new material is linked with as much of the student's past experience as possible.

Counterpoint - x's followed by o's on alternate pages appear to merge and become (X) when the pages are flicked through. If two concepts are discussed alternatively they too will appear to merge.

These techniques are used in the programme and, together with introductory frames and summary frames, serve to present the section as one recognisable unit with a specific purpose rather than a collection of many isolated parts. The programme should read easily and flow smoothly, with each sequence neatly interlocking with those which precede and follow it.

Motivation Throughout programme writing student motivation must be considered for if the student loses interest and fails to complete the work the programme objective cannot be achieved. It is true that the students attempting this programme will be examination candidates, therefore they will have an added external motive for perseverance but it is also true that many of them will not be dedicated students. Any factor included in the programme which contributes to motivation will contribute to the learning which will occur.

Attention can be focused and persistence fostered by providing a clear and attractive programme layout. Content material should be presented in a way likely to arouse and hold interest, and auxiliary material may be included for enrichment or to provide continuity.

A variety of response types should be considered and correct response rates should generally be high for those who are working well. The programme must, however, be challenging - if it is too easy boredom may set in.

7. Frame Sequence Evaluation and Editing

Once the programme is written it is given repeated empirical try-outs, interspersed with revisions until its performance matches that formulated in the programme planning stage. This process is very time-consuming and Bjerstedt (1967) suggests that much time can be saved by a systematic examination of the programme materials before empirical testing.

The most frequent faults in programming at this stage are too little or too much prompting, lack of practice items, failure to fade prompts, inclusion of irrelevant material and irrelevant responses, the occasional eliciting of material before it is taught, failure to integrate teaching points and the absence of summary and criterion items.

In order to eliminate these mistakes at an early stage it is useful to take an inventory of the first draft of the programme. The programmer can then see what the relationship is between items and adjustments can be made before typing and duplicating the first validation copies.

During the validation runs, if any weakness becomes apparent, it can be quickly ascertained how many frames have been allocated to the concept concerned and also how it fits into the overall pattern of the programme.

In the first draft of the programme a minimum of prompts and practice should be used (Markle 1964). Empirical testing in programme development will show if and where additional frames are necessary until the optimum level is reached. If unnecessary material is included at the outset it is not possible to pinpoint redundant material.

Analysis and Recording of Learning Programme Structure.

A number of methods of analysing and recording programme structure have been proposed. Some are compiled before writing the programme, some as it is being written or on completion of a small section and some when the programme has been written. The information recorded may include the number and location of frames for each teaching topic, frame content, frame function and the programming techniques used. The purpose of the exercise also varies. The chart may be compiled to assist the programmer by forecasting his requirements, it may help him to focus on a particular point while writing the frames or may assist in 'trouble-shooting' in the immediate post-writing phase. It will be suggested that such a chart could serve to clarify the reason for failure of a frame or teaching sequence during the analysis of field test data.

Survey of proposed systems A number of methods of recording programme structure are considered at this point before describing the system which has been developed in this study.

Thomas et al. (1963) devised the 'flow-chart' which was to be constructed before frame writing. The frames are categorized to illustrate the content and function of frames in a limited way. Rules (R), examples (E), generalisations (G) and discriminations (D) are plotted for each teaching point. This arrangement makes evident the fading of prompts and the location of revisionary material. The system allows a survey of the number of frames and the overall teaching pattern for each teaching point. Little information is available within each of these. A large proportion of all frames are shown as examples. The aim of this flow chart is to assist the novice programmer but the system assumes that he will be able to estimate the number and type of frames he will require to achieve his objective.

Becker (1964) suggests compiling a flow chart after a short section, say 40 frames, of the programme has been written. The function of his chart is to enable the novice programmer to check his efforts in adhering to the principles of programming. He uses geometric symbols to plot the use of four programming techniques (i) a frame with a temporal prompt, (ii) a frame with any other prompt, (iii) a frame with no prompt and (iv) a frame with material mentioned but not taught.

Errors such as irrelevant frames, numbers of frames, failure to fade prompts, too few practice frames, faulty teaching point integration and material which is elicited before being taught become evident with the use of this 'inventory'. This system is of limited use, however, because it considers programme teaching techniques only. It facilitates fault finding in a restricted area and is of use in the immediate post-writing phase of programme construction only.

An extension of this system was proposed by Hartley (1964b). Geometric symbols were used to plot three functions of frames (i) introduce a new rule, (ii) rule with example or examples, (iii) practice frame and combined with these the use of a prompt, of no prompt, of thematic prompts and formal prompts which are shown by degrees of shading. Other functions such as (iv) direct instruction, (v) summary, (vi) test and (vii) no response required were plotted with letters. Increased information including the purpose of the frame was included in this system which is simple for the novice to use.

Franklin's (1964) system concentrates on the function of each frame which must be plotted as the programme is written. Five types of frames are recognised: I introduce, D define, T teach, Te test and R review.

This method requires the programmer to consider the function of each frame as he writes it and provides a record of the treatment of the various teaching points. This system is perhaps the most useful in helping to achieve the programme objectives although frame content and the programming technique used are not recorded.

In 1965 Hartley and Franklin suggested a more complex system of symbols and letters covering purpose, content and technique. While having many advantages it is difficult to read and may confuse the novice programmer.

Discussion Time spent on programme writing can be reduced to a minimum if the programmer critically assesses the first draft for programming errors before field testing. The object of the systems described above is to enable new programmers to write effective programmes. The flow chart can be of use to all programmers by enabling them to examine systematically their efforts in the light of the generally-accepted principles of programming. It must be remembered, however, that many of these principles are still untested assumptions as to what goes to make an effective programme. Any interpretation of the possible effectiveness of the programme from the flow chart will be purely subjective.

The charting system which follows is an attempt to represent in graphic form the content, purpose and programming technique used in each frame of this programme. While it can be of use to the programmer in the immediate post-writing stage it will be of more value during the analysis of data resulting from the field test. The final criterion of the effectiveness of any programme is the student's terminal behaviour as shown by the terminal test. If this behaviour is inadequate or the time taken is too long then an analysis of student behaviour within the programme must follow. The criterion test will indicate which teaching point was not effectively taught, the frame error rate along with the flow chart where the fault occurs in the programme and the flow chart the possible causes of the faulty sequence. Thus the flow chart can be of assistance to the programmer when reconsidering his efforts, particularly at the field testing stage.

Analysis and Recording of the Learning Programme Structure

The programme charting system outlined here was used in the developmental stage of programme construction. The system has two subdivisions: the first records the content of each section, the function of each frame and the number of frames per teaching point and the second the programming techniques used.

In Part 1 each teaching point is indicated in the order in which it occurs in the programme as shown in Figure 5.2 and the number of frames per teaching point is listed. The function of each frame is entered on the chart using Franklin's (1964) classification. Thus this part of the flow chart records visually (i) teaching points, (ii) order of teaching point presentation, (iii) the function of the frames within the teaching point sequence (iv) number of frames per teaching point and (v) the phasing of teaching point introduction.

In part 2 the type and strength of prompts is recorded along with the method of linking teaching point sequences. Becker's (1964) method of presenting the strength of prompts is used. Thus this diagram indicates (i) the type of prompt (ii) fading of these prompts, (iii) irrelevant responses and (iv) the concept linking method used.

Figure 5.2 was compiled from the penultimate version of the learning programme (Appendix ix) and covers the five programme sections. The chart was used along with criterion test results and frame error totals to make the final programme revisions. A similar flow diagram could be constructed on completion of the first programme draft or at any subsequent stage of programme development and would provide useful information on which to base programme revisions.

SECTION 1

ANALYSIS AND RECORDING OF PROGRAMME STRUCTURE

PART 1 Content of Section/Function of Frames (After Franklin 1964)

(Compiled from the penultimate programme - Appendix (viii))

	Frame Number																																		No: of frames
	1	2	3	4	5	6	7	8	9	10	11	12	13	14	15	16	17	18	19	20	21	22	23	24	25	26	27	28	29	30	31	32	33	34	
1	Introduction																																		3
TEACHING	I I I																																		3
	D																																		
2	nunatak																																		2
TEACHING	T Te																																		2
	Te																																		
3	iceberg																																		2
TEACHING	D Te																																		2
	Te																																		
4	snowfield																																		7
TEACHING	I T T T T T Te																																		7
	Te																																		
5	snowline																																		4
POINT	I T T T T T Te																																		4
	Te																																		
6	e.g. snowfield																																		3
POINT	I T D Te																																		3
	D Te T																																		
7	avalanche																																		1
POINT	D Te T																																		1
	T																																		
8	corrie																																		2
POINT	D Te																																		2
	D Te																																		
9	snow to ice																																		4
POINT	I T T Te																																		4
	Te																																		
10	glacier																																		5
POINT	I D T Te R																																		5
	R																																		

KEY
 I Introduce
 D Define
 T Teach
 Te Test
 R Review

PART 2 Programming Technique

Frame Number	1	2	3	4	5	6	7	8	9	10	11	12	13	14	15	16	17	18	19	20	21	22	23	24	25	26	27	28	29	30	31	32	33	34
--------------	---	---	---	---	---	---	---	---	---	----	----	----	----	----	----	----	----	----	----	----	----	----	----	----	----	----	----	----	----	----	----	----	----	----

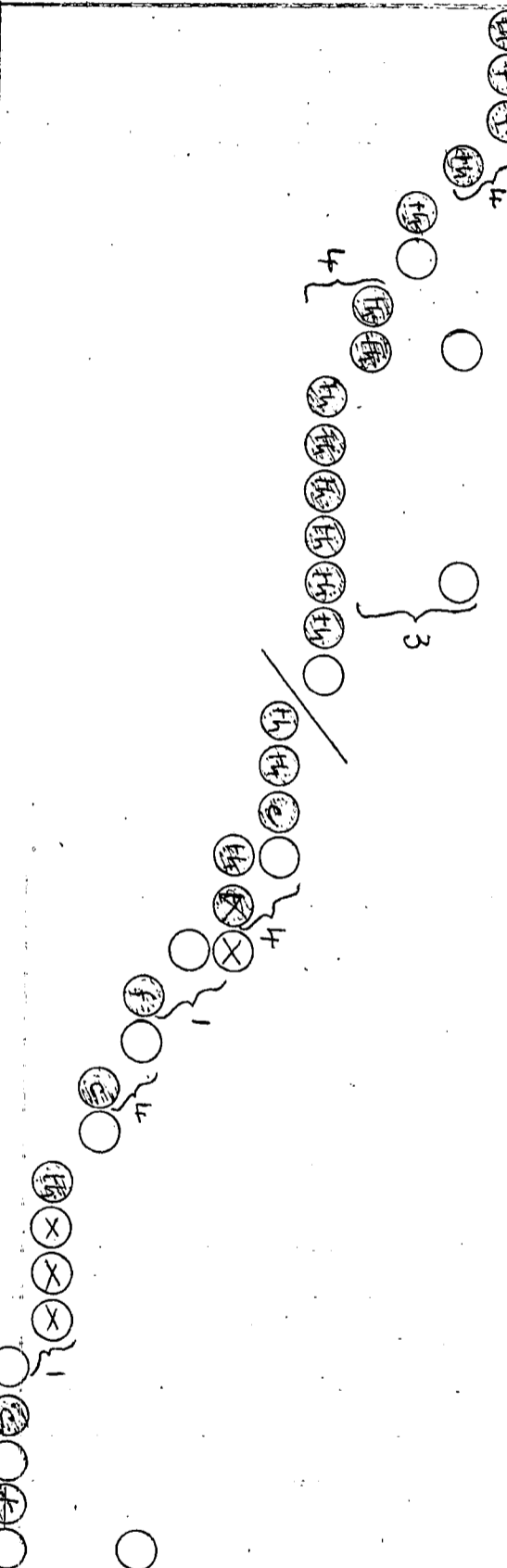

KEY
Type of Prompt
 (c) copy
 (e) emphasis
 (f) formal
 (t) temporal
 (th) thematic
 (p) prompt
 (x) to test/programme objective

Fading or Vanishing (after Becker 1964)
 (p) prompt
 (t) temporal prompt
 (x) no prompt
 Irrelevant Response
 (x) Method of Linking Teaching Points

Figure 5.2

Analysis and Recording of
Programme Structure - Section 1

(Sections 2-5 in Appendix ix)

Editing

The first draft of the learning programme requires a close scrutiny to check the material and its presentation. At this stage a specialist Geography teacher was asked to comment on the accuracy and relevance of the material and the suitability of vocabulary and examples for secondary pupils, while an English specialist surveyed the programme with particular reference to style, clarity, continuity and interest.

The layout of text and diagrams was also considered. The adequacy of instructions on the programme learning method was checked and answer sheet design reviewed. It was decided to produce each section in a separate book for convenience in use.

At this point the programmer can also check to see that he has in fact produced the material intended. Answers to such questions as: Has the frame a purpose? Is the purpose of the frame or the response it elicits relevant to the programme objective? Is the material taught before the response is called for? all supply information on which changes can be made.

The programme is now typed and ready for validation. A copy of this version of the programme with post-tests is presented in Appendix (v).

Chapter 6

VALIDATION

A learning programme is responsible for what the student learns and the way in which he learns. The main objective of the programme is that the target population should reach the specified criterion behaviour.

Dodd (1965) points out that any teaching, testing or motivating action included in the programme which is not effective must be replaced. At this stage in programme development the programme contains what - in the programme writer's subjective view - is required for the student to reach the expressed goal. Whether this, in fact, is the case is put to the test during validation. Programming is pragmatic - what works is kept; what fails is replaced. Validation consists of a series of testing, analysis and revision cycles based on the student behaviour which results from programme study.

Programme revision based on student behaviour has been a feature of programming from its outset. Skinner considered that programme refining continued until the point where the average child had almost complete success. In the early days, however, much more emphasis was placed on the elimination of frame errors than is the case today. In Leith's (1969) view the percentage error on individual frames is an imperfect guide on how to improve a programme. He suggests that tests within the programme and after its completion are the only proper guides.

The revisions in this programme have been based on the four kinds of data proposed by Jacobs et al. (1966):- (i) changes in achievement; (ii) frame error rate; (iii) programme completion times; (iv) student attitudes.

(i) Changes in achievement - students complete the criterion test as a pre-test and a post-test at each programme trial stage during validation. The tests provide the most important evidence of programme effectiveness. If a high level of learning is indicated then the programme is achieving its aim; if not, revisions must occur. But what, in fact, is an acceptable level of learning? The aim must be to achieve the objective specified in the programme. One hundred percent success on the criterion test is the ideal but, in fact, the level of achievement expected must be a realistic one based on classroom experience. Blake (1966) suggests that agreed statistical criteria be set up so that a programmer will know when to end testing and revision.

Blake (1967) proposed the gain ratio as the criterion on which to base decisions about programme revision. His ratio has been used in programme validation here. The gain ratio is a modification of that proposed by McGuigan (Popp & McGuigan 1963). McGuigan compared the difference between means $(m_2 - m_1)$ ¹ and the difference between the maximum score (p) and the pre-test mean (m_1).

1 m_1 = mean score of first test

m_2 = mean score of second test (post-test or retention test).

Blake modified McGuigan's ratio by adding the term $\frac{m_2 - m_1}{p}$ to allow for student pre-knowledge. If the gain ratio calculated by the formula $\frac{m_2 - m_1}{p - m_1} + \frac{m_2 - m_1}{p}$ is more than 1.2 the achievement gain is considered satisfactory.

The pre-test and post-test results are also used to investigate the possible occurrence of reversals. A reversal is shown by an incorrect answer in the post-test following a correct answer to the same question in the pre-test. Reversals are a direct result of confusion caused by the programme itself.

(ii) Frame error rate The failure of the student to answer any of the criterion questions to an acceptable level results in the programmer looking at first at the test. If the reason for failure is not in the test it may be in the key frame i.e. the test frame within the programme or in the sequence of frames which have been used to teach the particular point leading up to the key frame. At this point in analysis the student response frame error rate will help to locate the cause of failure. A sufficient number of errors are taken to indicate misunderstandings which are blamed on the programme and lead to revisions. In general a high level of success is looked for in student frame response. The criteria of 5% error on key frames and 10% error overall is taken as the aim but too much is not made of this for the final criterion of the effectiveness of the programme is the student's terminal behaviour.

As Bjerstedt (1965) points out, if student terminal behaviour reaches acceptable levels within a reasonable period of time we need not be too concerned about the details of behaviour within the programme.

(iii) Time scores The programme section is designed for use within a lesson period. If five minutes are allowed for administration and five minutes for the section test the time available for programme study is 25 - 30 minutes. Programme revisions must bear in mind that virtually all students should have time to work through the programme.

(iv) Student attitude Student reaction was sought in the preliminary trial and students involved in the Final Validation were asked to fill in a questionnaire (Appendix (iv)). The questionnaire attempts to discover student interest in this method of instruction.

Figure 6.1 is a flow diagram which presents in visual form the various stages in programme development. It shows that a representative group of students attempt a pre-test before studying the learning programme and a post-test on its completion. Evidence provided by the tests, frame error rates, programme working time and student attitude all provide evidence on which to base amendments to the programme should this be necessary. This process is repeated again and again until the criterion performance is achieved.

Figure 6.1

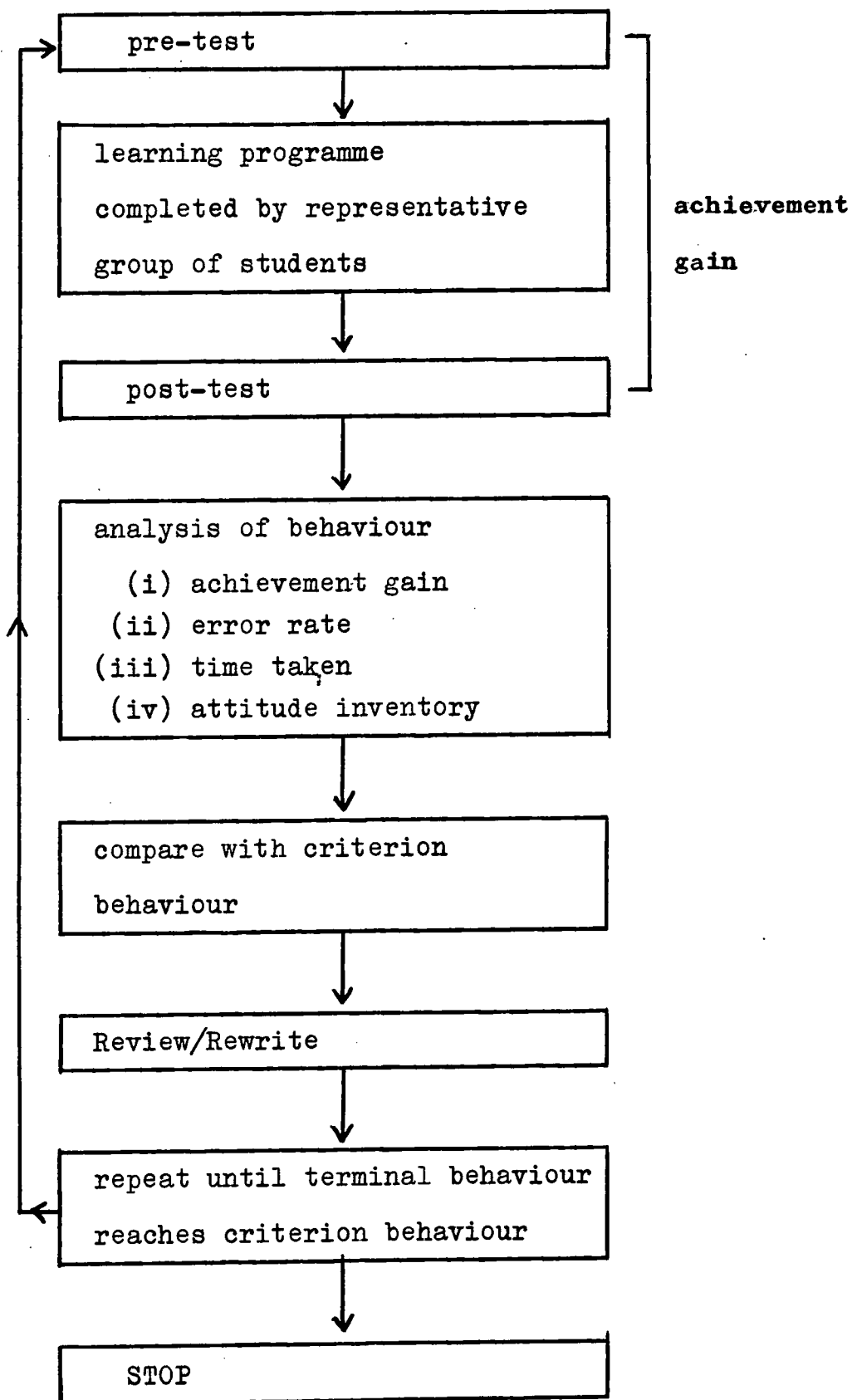
Learning Programme Validation Procedure

A discussion of the various stages in the development of the glaciation programme now follows. It shows that four cycles of programme testing and review were found to be necessary for this programme.

The pupils taking part in programme validation were typical of those for whom the programme is intended. None of these pupils had studied glaciation previously.

Because the pupils had no previous experience of the programme learning method it was necessary to explain this at the outset and a few practice frames were completed and discussed. The pupils were aware that the teaching material only was being tested.

Although 'cheating' does not prevent learning it can be misleading when attempting to validate a programme. For this reason the programme was presented in the form of a pack of individual frames with confirmation on the reverse in the first two trials. This ensured that each pupil actually responded to the frame before turning over to check the response.

Efforts were made to provide ideal conditions for study with a minimum of interruptions. Also all instructions, answer sheets, tests and the programme itself were clearly typed so that the results obtained were a true reflection of programme content.

In the preliminary trial four students completed a section of the learning programme and a criterion test (Appendix v) in each of five sessions. One of these students was above average, two average, and one below average ability in geography as assessed by the class teacher. Each student entered starting and completion times and frame responses on a prepared answer sheet and was encouraged to write comments on any difficulties as they arose. The programme writer was available to answer queries as they occurred and made a note of frames which appeared to cause difficulty and delay.

As a result of this trial a number of defects became apparent. Amendments were made to the criterion test and to frames which were inadequate. Steps were taken to shorten all sections and some irrelevant material was deleted.

FIELD TEST 1

The revised programme (Appendix (vi)) was studied by a class of thirty representative pupils. These pupils completed a pre-test prior to this work and a post-test after each programme section. The pre- and post-tests were parallel tests. In this version of the programme Sections 4 and 5 are reversed so that the map interpretation of glacial highland features follows immediately after a study of the theory of this topic.

The number of pupils attempting the programme sections decreased from the maximum as work progressed. Data is recorded for each section and includes the total number of pupils who completed each section. The total programme data refers to pupils who completed all sections of the programme.

Table 6.01 Field Test 1 - Pre-Test Scores.

Sections	Maxm.marks per section	Number of Students	Total Poss. Score	Actual Total	mean score	% success
1	10	30	300	57	1.9	19
2	15	29	435	19	0.66	4.37
3	20	29	580	18	0.62	3.1
4	15	24	360	0	0	0
5	5	23	115	5	0.22	4.35
TOTAL	65	21	1365	77	3.67	5.64

The low pre-test percentage success rates shown in Table 6.01 indicate that the material presented in this learning programme is largely new to the pupils. The content of Section 1 was slightly more familiar than that of other sections.

Table 6.02 gives relevant score details for the post-test. The total possible scores in this test are the same as for the pre-test.

Table 6.02 Field Test 1 - Post-Test Scores

Sections	Total Actual Score	mean score	% success	Gain Ratio
1	223	7.43	74.33	1.23
2	250	8.62	57.47	1.09
3	282	9.72	48.62	0.93
4	235	9.79	65.28	1.30
5	55	2.39	47.83	0.88
All Sections	812	38.67	59.49	1.11

The mean scores for these two tests have been used to calculate the gain ratio~~x~~ for each section and for the programme as a whole. The gain ratio for sections 1 and 4 have just reached an acceptable level, the others have not. It was considered necessary to make a detailed analysis of post-test performance for each teaching point and to calculate frame error rates in order to pinpoint areas in the programme requiring improvement. In general a score of less than 70% (Blake 1967) on the criterion test item and over 10% frame error rate received investigation and amendment. A detailed analysis of section 2 post-test results and frame error rates is given in Table 6.03. A similar analysis for the remainder of the programme is recorded in Appendix (vii).

Table 6.03 Field Test 1 - Post-Test Analysis for
Section 2.

<u>Question</u>	<u>Teaching Point</u>	<u>% success</u>
1	glacier movement {slowest reason	65.51 86.2
2	{crevasse causes sérac	75.86 75.86 62.07
3	{moraine causes	68.93 51.7
4	moraine types	13.79
5	river starting as a glacier	82.75
6	diagram	68.93
7	moraine-dammed lake	93.1

In section 2, for example, the level of success in the first part of question 1, the third part of question 2 and questions 3, 4 and 6 resulted in investigation of, first, the post-test question itself and then the frame error rates for test frames and frames dealing with these teaching points. In addition any frame with more than 10% error received attention. The frame error scores are given for section 2 in Table 6.04 and for the rest of the programme in Appendix (vii).

Table 6.04 Field Test 1 - Frame response error scores -
Section 2 (n²⁹)

Frame	%	Frame	%	Frame	%	Frame	%
1	10	10	15	18	{21	24	41
2	15	11	0		{31	25	28
3	7		{17		{34	26	41
4	38	12	{17	19	{34		{55
{a	10	13	0		{15	27 A	{15
5 {b(i)	38	14	{24	20	{0	B	{17
{b(ii)	45		{63		{21		{41
6	7		{7	21	{0	28	{7
		15			{15		
7	{17		{17			29	63
	{34	16	24	22	10		24
8	21		{10	23	{15	30	24
		17	{34		{24	31	
{(i)	7						
9 {(ii)	28						
{(iii)	28						

Table 6.05 shows that all students in sections 2, 3 and 4 completed the section while sections 1 and 5 were not completed by 7 and 6 students respectively. Programme revision takes into account the necessity of shortening the time requirement for sections 1 and 5.

Table 6.05 Field Test 1 - Mean Programme Working Time

Section	Mean time in minutes	Students failing to complete
1	25.97	7
2	23.79	-
3	24.2	-
4	14.6	-
5	25	6

FIELD TEST 2

The revised programme (Appendix viii) was duplicated in booklet form with a vertical progression. 51 girls were introduced to the project by reading 'About this booklet' and 'How to use the programmed sections of this book' before studying the glaciation programme. All pupils completed a pre-test before study, a post-test at the end of each section and a retention test three weeks after study. The pre-test and retention test were identical tests and the post-test a parallel test. Because all pupils did not possess the assumed pre-knowledge relating to grid reference (34 correct) and direction (41) these concepts were revised before programme study began.

The pupils undertaking this work were in the 13 year 6 month - 14 year 6 month age range with a mean General Intelligence of 85.63 AH₄¹ raw score (range 49 - 109).

The pre-test data in Table 6.06 indicates that, in general, knowledge of programme content is low with section 1 containing the most familiar material.

1 AH₄ A.H.W.Heim Group Test of General Intelligence N.F.E.R. 1967.

Table 6.06 Field Test 2 - Pre-Test Scores (n 51)

Sections	Maxm. marks per section	Total Poss. Score	Actual Total	Mean Score	success
1	10	510	141	2.76	27.65
2	15	765	19	0.37	2.48
3	20	1020	21	0.41	2.06
4	5	255	18	0.35	7.06
5	10	510	11	0.22	2.16
All Sections 60		3060	210	4.12	6.86

The post-test data in Table 6.07 gives satisfactory gain ratio for sections 2 and 5 only so that programme revision is again necessary. A detailed analysis of each section post-test was carried out and this appears in Appendix (x).

Table 6.07 Field Test 2 - Post-Test Scores (n 51)

Section	Actual Score	Mean Score	% success	Gain Ratio
1	381	7.47	74.71	1.12
2	562	11.02	73.46	1.44
3	550	10.78	53.92	1.05
4	162	3.18	63.53	1.13
5	330	6.47	64.71	1.27
All Sections	1985	38.92	64.87	1.20

A summary of the success rate for each section is tabulated in Table 6.08. It shows that four teaching points in Section 1, five teaching points in Section 2, ten in Section 3, three in Section 4 and three in Section 5 require particular attention. Section 3 appears to have been the most unsatisfactory part of the programme.

Table 6.08 Field Test 2 - Summary of Teaching Point Success
as indicated by Post-Test Results

% score	Section 1	Section 2	Section 3	Section 4	Section 5
1-20			3b(i)		
21-30			6c		
31-40	1(i)	3(iii)	3b(ii), 6a		
41-50			3c, 5(i)		
51-60	3(snowfield)	2c, 3(i) 3(ii)	3a examp.	arête, corrie	4(ii), 4(iii)
61-70	4	2b(i)	3a, 4, 6b	hang.valley U valley	4(i)
71-80	1(ii), 2, 5	2a, 2b(ii), 5	5(ii)	ribbon lake	3
81-90	5 pressure	1a, 1b			
91-100	3(corrie), 6, 7	4, 6	1, 2		1

Frame error rates were compiled for each section (Appendix (x)) and on this occasion key frames are indicated along with the number of no responses per frame.

As in Field Test 1 programme revision started with a scrutiny of the post-test question followed by the teaching point key frame response and then the sequence of frames leading up to the key frame. As a result of this analysis the position of the programme failure becomes evident. At this point the programme structure charts (page 71 and Appendix(ix)) were used in an effort to ascertain the reason for failure.

Reversals Questions which were answered correctly in the pre-test and incorrectly in the post-test (reversals) were plotted for all sections. A summary of this information is given in Table 6.09. A reversal gives evidence of muddle which is caused by the programme itself. Reversal scores in this programme are low. This is explained by the fact that apart from Section 1 scores on the pre-test were very low as pupils had little knowledge of the subject at the outset. With the exception of questions 1(ii) and 7 all reversals were isolated cases. In both 1(ii) and 7 the reversal seems to have been caused by a faulty teaching sequence.

Table 6.09 Field Test 2 - Reversals

Section	Total	5% of pupils
1	13	2
2	3	-
3	3	-
4	1	-
5	5	-

The retention test results and gain ratio scores¹ are listed in Table 6.10. In all cases the gain ratio has fallen and particularly so in sections 2 and 5, where it appears that more practice and review items are necessary. Results in Section 1, where some knowledge of the content material was already part of the students repertoire when work began was the most stable.

1 Blake does not suggest a satisfactory gain ratio level for retention.

Table 6.10 Field Test 2 - Retention Test Scores (n 49)
(after 3 weeks)

Section	Total Actual Score	Mean Score	% success	Gain Ratio
1	339	6.92	66.47	1.01
2	318	6.49	41.57	0.83
3	399	8.14	39.12	0.66
4	96	1.96	37.65	0.8
5	156	3.18	30.59	0.6
All Sections	1308	26.69	42.75	0.78

A detailed analysis of each retention test appears in Appendix (x) and a summary of the content is given in Table 6.11.

Table 6.11 Field Test 2 - Summary of Teaching Point Success
as indicated by the Retention Test

% score	Section 1	Section 2	Section 3	Section 4	Section 5
0-10					3(iii)
11-20		2(ii)	3a example, 3b(i)+(ii)		4(iii), 5(i),5(ii)
21-30		3(i)	4b diagram	corrie	1
31-40	1(ii),4sn.	3(ii),4(i) 4(iii),6	1,3a,3b(i), 4b,4d	arête	2,3(i),3(ii)
41-50		5	4c		
51-60		7		'U'valley	4(ii)
61-70	2,6glacier	1a,b,2(i)	3c,4a,5a		4(i)
71-80	1(i) 5	4(ii)	2, 5b		
81-90	3,4 corrie 6 avalanche 7				
91-100				ribbon lake	

The mean working time for the whole learning programme is 117 minutes. A wide range of working time was required by the pupils who worked at their own speed within the lesson periods. Table 6.12 shows that some pupils in the first four programme sections failed to complete the programme within the time available to them. As all students must have adequate time to do the work required programme revision must take this into account. There is time available for additions to Section 5 if it is required.

Table 6.12 Field Test 2 - Programme Working Time (n 51)

Section	Time in Minutes	Mean Time	Time Range	Incomplete attempts
1	1254	24.59	16-30	11
2	1401	27.47	20-35	1
3	1148	22.51	15-28	6
4	1369	26.84	10-33	13
5	802	15.73	11-21	-
All Sections	5974	117.14	-	

The time requirement can be reduced by eliminating any unnecessary material (material not strictly relevant to the programme objective), by improving clarity, by simplifying instructions and response requirements where this will not impair teaching efficiency.

Types of Programming Faults

The most frequent types of faults which occur while programming according to Callender (1969) are overprompting, underprompting, including irrelevant information, eliciting no response, failing to fade prompts, providing insufficient

practice items and calling for irrelevant responses. Mills (1969) analyses the cause of frame errors into those due to (i) operational factors; (ii) memory defects; (iii) defects of understanding and (iv) faulty programming. The first and last of these are of particular interest when programme revision is being considered.

Programme faults which became evident while revising this programme are summarized here:-

1. Occasional typing errors.
2. Ambiguities or lack of clarity in instructions, in test questions and in frame teaching and response eliciting components.
3. Frames too long and involved especially when introducing new material.
4. Occasionally facts tested but not taught.
5. Teaching sequences inadequate.
6. Irrelevant material in the frame.
7. Frames calling for an irrelevant response.
8. Frames which elicit a correct response but do not teach, cueing is good but not sufficiently faded. This is seen particularly well in the map reading section where frame errors are generally low but key frame errors are high.
9. Order of teaching point presentation.
10. Insufficient practice frames and summary and review frames. This can be seen clearly in sections 2 and 5 where new material did not hold up well in the retention test.

During the programme rewrite it was usually possible to amend the programme by rewording the faulty frames and sequences rather than by adding extra frames.

Efforts to ensure Optimum Operational Conditions

During this exercise it is important to remove anything which will interfere with or have an adverse affect upon results so that the true effectiveness of the learning programme can be assessed. At this point, before the final validation procedure was undertaken, a number of points were considered:-

1. More time to be spent explaining the project to the pupils in order to get their interest and cooperation.
2. Because programmed learning is new to the pupils:-
 - a) take more time explaining 'About this booklet'
 - b) extend the practice frames in 'How to use the Programmed Sections of this book'.
3. Any pupil having difficulty with the programme, as shown by the frame response error rate on the answer sheet at the end of Section 1 in the final validation, to be given extra tuition in the programme learning method.
4. Establish that all pupils are familiar with Ordnance Survey maps and are at ease with the use of contours, grid references and direction before the programme begins.
5. Administrative arrangements to be checked so that booklets and prepared answer sheets are available, rooms checked, interruptions reduced to a minimum.
6. Have the original photographs available in case individual photocopies give difficulties.
7. Produce only the map area necessary for Section 4 so that there is no possibility of time wasting or answers given from the inadmissible areas of the larger map.

FINAL VALIDATION.

The revised programme (Appendix (iii)) consists of a total of 144 frames divided into five sections. This was now worked by 34 pupils in the 13 yr 6 month - 14 yr 6 month age range. The General Ability (AH₄) mean score of the group was 87.32 (S.D. 11.71)¹.

Each pupil completed a pre-test, a post-test after each section and a retention test one month later. An identical test (Appendix (ii)) was used on each occasion for this validation. Pre-knowledge questions were rephrased and extended (questions 1, 2 and 3 in Section 4 of the pre-test) in an attempt to ascertain pupil familiarity with the concept of contours as well as direction and grid reference. Scores were relatively high but these points were revised in class before work began.

All results obtained from this validation trial and used in the programme analysis are recorded in Appendix (xi).

The pre-test data in Table 6.13 shows that again knowledge of programme content material is low with Section 1 gaining the highest scores. In this group some pupils showed evidence of some knowledge of Ordnance Survey map interpretation.

The post-test data in Table 6.14 shows a gain ratio for the whole programme of 1.38 and reaches the criterion set for an acceptable level of programme efficiency.

¹ Nonorms have been published for this type of school.
Grammar School Mean Score 85.26 (S.D. 11.21)
Secondary Modern School Mean 59.51 (S.D. 19.50).

Table 6.13 Final Validation - Pre-Test Scores (n 34)

Section	Maxm. marks per section	Total Poss. Score	Total Actual Score	Mean	% success
1	10	340	103	3.03	30.29
2	15	510	20	0.59	3.92
3	15	510	42	1.24	8.23
4	5	170	35	1.03	20.59
5	10	340	9	0.26	2.65
All sections 55		1870	209	6.15	11.18

All sections dealing with the theory of glaciation also reached an acceptable level although Section 3 is still the least efficient. Efforts to improve Section 4 which deals with the interpretation of glacial features on an Ordnance Survey map, however, have met with little success. It may be that the pupils do not have the necessary contour interpretation skills necessary for this work. If this is so the pre-knowledge test question dealing with this point is clearly inadequate.

Table 6.14 Final Validation - Post Test Scores (n 34)

Section	Total Poss. Score	Total Actual Score	Mean Score	% success	Gain Ratio
1	340	305	8.97	89.71	1.44
2	510	411	12.09	80.59	1.57
3	510	355.5	10.46	69.61	1.28
4	170	91	2.68	53.53	0.75
5	340	253	7.44	74.41	1.46
Total Programme	1870	1415.5	41.63	75.70	1.38

An analysis of frame response errors recorded in Appendix (xi) is presented in Table 6.15. The error score for key responses is 6.92%. The overall error score for the whole programme is 5.8%. Error scores in Section 4 are still too high but if, as seems likely, the pupils have not the necessary skills for this work further revision of Section 4 in its present form would not solve the problem.

Table 6.15 Final Validation - Frame Response Errors (n 34)

Section	No. of frames	No. of responses	Total Poss. responses	Response errors	% response errors	% key errors
1	28	39	1326	38	2.87	2.94
2	32	47	1598	81	5.07	4.41
3	30	53	1802	114	6.33	5.74
4	21	29	986	134	13.59	19.11
5	33	52	1768	67	3.79	4.81
Total	144	220	7480	434	5.80	6.92

Sections 1, 2, 3, and 5 taken by themselves teach all the material necessary for the theory of glaciation in the G.C.E. examination and could be used as a logical unit of presentation. In fact no examination question has been set by the Joint Matriculation Board on this topic on map interpretation in recent years (page 35).

Tables 6.16 and 6.17 summarise the test results and frame response errors for these four sections of the programme taken as a unit. The gain ratio for this unit is 1.43. The key response errors and overall response errors are 4.71% and 4.6% respectively.

Table 6.16 Final Validation - Gain Ratios for 4 Section only

(n 34)

	Individual Poss. Score	Total Poss. Score	Total Actual Score	Mean Score	Gain Ratio
Pre-test	50	1700	174	5.12	-
Post-test	50	1700	1324.5	38.96	1.43
Retention Test	50	1700	898	26.41	0.9

Table 6.17 Final Validation - Frame Response Errors (4 Sections)

(n 34)

Maxm. Ind. Response	Poss. total errors	Response errors	% respon. error	Poss. key errors	Total key errors	% key errors
191	6494	300	4.6	1870	88	4.71

At this point a correlation was calculated between a school geography examination mark for the pupils concerned and their General Intelligence raw scores. The correlation of 0.3878 is significant at the 5% level. A similar correlation between achievement as shown by the programme post-test and pupil ability is 0.6039 (sign. at 1%).

An inverse correlation significant at the 5% level exists between post-test scores and frame response errors (-0.4300).

The retention test results are summarised in Table 6.18. The gain ratio is approximately 1 in the first three sections appears to be satisfactory. Section 4 gain score is, however, low and an extensive loss has occurred in Section 5.

It appears that further practice and review frames are required in Section 5.

Table 6.18 Final Validation - Retention Test Scores

(After 1 month) (n 34)

Sections	Total Actual Score	Mean Score	% success	Gain Ratio
1	229	6.74	67.35	0.9
2	292	8.59	57.25	1.09
3	275.5	8.10	53.92	0.96
4	77	2.26	45.29	0.56
5	101.5	2.99	29.85	0.55
Total	975	28.67	52.14	0.87

A correlation of 0.7850 (sign. at 1%) exists between post-test and retention test scores.

The programme completion times (Table 6.19) indicate that the time now available for working each section is adequate. Only one student failed to attempt three frames in the whole programme. The maximum time taken by any pupil was 130 minutes and the average time requirement was 108 minutes.

Table 6.19 Final Validation - Programme Working Time (n 34)

Section	Time in Minutes	Mean Time	Time Range	Incomplete attempts
1	610	17.94	13 - 23	-
2	710	20.88	15 - 27	1
3	758	22.29	18 - 29	0
4	820	24.12	14 - 32	-
5	771	22.68	10 - 28	-
Total	3669	107.91	90 - 130	

Programme Specification

This learning programme has been developed for use with above average ability (AH₄ range 55 - 107) third year secondary pupils (13+ - 14+) in the school situation. It is suitable for work in the classroom and for private study.

The programme is designed to satisfy the requirements of the J.M.B. G.C.E. 'O' Level syllabus on the topic of glaciation. It can be used by itself or integrated into a scheme of work.

As a result of working the programme pupils should be able to achieve an overall gain ratio of at least 1.2 when answering the section tests.

The learning programme totals 144 frames and is divided into five sections. Each section including the section test requires a lesson period of 35 - 40 minutes. The average working time for the whole programme is 108 minutes.

Questionnaire information

A further assessment of the learning programme can be obtained by studying the responses the pupils made to a questionnaire (Appendix iv) which was completed after working through the learning programme.

Effect of Programmed Learning method on pupil preference for Geography

The pupils were asked to arrange the academic subjects which they study, in order of preference, before and after they had used the programme.

Subjects were ranked from 1 to 10. None of the group studied Spanish which is included in the list on the questionnaire. The result of this enquiry appears below (Table 6.20). The effect of the programme learning method has been to improve the interest in geography with the less interested pupils although one or two of those who were more interested have become slightly less so.

Table 6.20 Questionnaire - Order of Preference for Geography

	<u>Pre-Treatment</u>		<u>Post Treatment</u>	
	f		f	
1	2		1	1 is the most
2	4		4	favourable
3	5		4	
4	4		4	
5	5		5	
6	5		8	
7	-		3	
8	6		4	
9	2		1	
10	1		-	
<u>Total</u>	<u>34</u>		<u>34</u>	

Attitudes of pupils to the programmed learning method

A Likert type scale was used to assess pupil reaction to the programme learning method - this was a five point scale ranging from 'much more' to 'much less'.

A generally favourable attitude was expressed. This result is in line with Smith and Smith (1966) who summarised students' attitudes to programmed learning since 1960 'The initial reaction of learners to programmed self - instruction at all levels of schooling and in adult training situations has been generally favourable'.

This result, however, should be interpreted with caution because 1) the method was new to all pupils and, therefore, would have a novelty value (Hawthorne effect). 2) the programme was of too short a duration to judge its capabilities as regards providing continued interest and motivation.

Subjective views on whether the pupils thought they had learned more using this method were more evenly divided.

Summary of pupils comments on the programmed learning method.

Pupils were asked open-ended questions as to what they liked best and least about the method of teaching under study and were then asked to make suggestions which would make the learning programme (i) more effective (ii) more interesting.

What do you like most about the programme learning method?

A number of pupils thought the work appeared to be easier and liked working in their own time. 'You can learn at your own speed.' 'There isn't a teacher breathing over your shoulder.' All pupils were actively involved. 'You have to be alert all the time. There is no time to talk.'

'There is no chance of your attention wandering.'
 Immediate knowledge of results ~~were~~^{was} attractive: 'It was fun. You could see if your answers were right or not.' Some pupils liked the way it was set out; others found it more interesting and the absence of homework had a number of supporters.

What did you like least?

The time allowance was too short 'most times we were hurried' or too much was included in each booklet. A number of pupils complained of the test at the end of each section and the fact that no record of the topic would be available for later study was raised. Two pupils soon became bored and one observed that the teacher did not participate in the lesson.

Suggestions designed to make the programme

(i) more effective

It was thought that if the material was arranged in more sections more time would be available, and more repetition was advocated. One pupil asked for longer frames with an introduction to the section and a summary at the end. More diagrams, photographs, maps films and talks were called for.

(ii) more interesting

More visual aids of all kinds and the use of models and a visit to a glaciated area were suggested. Some pupils would prefer discussion or the teacher asking the questions instead of tests.

In conclusion

Although diagrams, photographs and maps form an integral part of the learning programme and have been used extensively in it there is still a demand for more. There is no doubt that fieldwork would improve the effectiveness of the work but difficulties will always arise because of the time required, numbers involved and, in this case, the availability of glaciated high-land area. A number of pupils prefer to work with the teacher and their peers and it is highly probable that these pupils would lose interest in the learning programme work after the initial novelty had passed.

Pupils working through this programme were restricted to the learning programme method but in the normal course of teaching the teacher can use the programme along with a number of other teaching tools. The programme should be integrated into a course of work rather than being the course of work - it should be used alongside visual aids, fieldwork, reference books and discussion. A varied approach can sustain interest and enthusiasm for the subject.

Chapter 7 PROGRAMME EVALUATION I - THE EXPERIMENT

The primary aim of the comparative experiment is to provide an objective assessment of the effectiveness of the learning programme by comparing its performance under controlled conditions with other methods of teaching the same material, in particular with the normal method of presentation. In addition the experiment may indicate the best role for the instructor when dealing with this type of instructional material.

The study aims to provide information, other than subjective impression, on the performance of the teaching material developed - the learning programme. The hypothesis which is investigated is 'That there is no significant difference between the three different teaching methods used in the experiment'.

The Experiment

The teaching objective is to promote a knowledge of the form and evolution of various landforms resulting from glaciation as required by the G.C.E. 'O Level examination and to permit their presentation by the student in written form.

The three teaching methods used were learning programme only, learning programme plus discussion and traditional methods.

The criteria used in the comparison were (i) recall of factual information; (ii) the comprehension of principles involved and the ability to deduce from

these principles and (iii) essay writing skill in the form of short descriptive answers to test the presentation of material in an ordered way.

Experimental Design

(a) Experimental material

The teaching topic was glaciation at the middle school level for pupils progressing towards G.C.E. in geography. This was presented in the form of the learning programme only in Group I. In Group II the learning programme was studied as homework assignments and these were followed by discussion and review. In the normal lesson presentation (Group III) care was taken to use the same material content but here use was made of the normal lesson 'tools' such as an atlas, maps, the overhead projection of photographs, Ordnance Survey maps and a textbook¹.

The experimental subjects were 84 third form girls in a High School in Northern England. The pupils entered the school, a 13 - 18 Comprehensive School, at the beginning of the third year of secondary education as the result of parental choice assisted by Headteacher advice. The pupils were given the AH₄ Group Test of General Intelligence in order to discover if the majority of the pupils did, in fact, approximate to known G.C.E. candidates in ability. The mean General Intelligence score (in raw score terms) is 80.38 (S.D. 13.10) and the average age is 14 years 1 month.

1 C. S. Clowser (1963) Physical and Human Geography - Blackie.

The National Norms for fourteen-Year-Old Grammar School children reported by Heim (1967) is 85.26 (S.D. 11.21).

Criterion tests (Appendix (xii)) were prepared to test the learning which occurred as a result of the various teaching methods employed. These tests consisted of:

(1) a criterion test which was completed by pupils in all teaching groups on three occasions - as a pre-test, as a post-test on the completion of instruction and as a retention test five weeks later. This test is a similar test to that normally given to the pupils on completion of the study of a topic in geography. The test is objective in nature in that questions are numerous so that most points taught are included and specific, leaving little room for subjective impression. This test covers the theory of glaciation only. Questions on map interpretation are given at a later date as is the writer's normal practice.

(2) A G.C.E. question on the theory of glaciation and a G.C.E. question on map interpretation. These tests were given nine weeks after instruction.

(b) The Experiment

The 84 pupils were allocated at random¹ to three classes on admission to the school at 13+ and these three classes were used as the experimental groups. Group I studied by learning programme only. Group II had learning programme and discussion. Group III had the normal lesson presentation.

1 Fisher, R.A. and Yates, F. (1963) Statistical Tables.
Oliver and Boyd.

In order to reduce personality effects to a minimum it was decided to make the class not normally taught by the experimenter Group I. The remaining classes were allocated to treatments arbitrarily.

Groups I and II were introduced to the programmed learning method of instruction and then all groups completed the pre-test before work began. Pupils were told that they were not expected to know the answers to the pre-test but that the experimenter needed to find out if anyone knew some or all of the answers at the outset.

All treatments were given to each group by the experimenter and in this way the staff variable was eliminated. The lessons were given over a period of three weeks at the times and in the rooms allocated to the respective geography classes on the school time-table. Teaching periods were of 35 minutes duration and particular care was taken to see that all lessons were of normal length and that abnormal interruptions did not occur during the experimental period. Table 7.1 shows that some classes had lessons early in the day or week while others were later. It was not possible to eliminate this variable.

TABLE 7.1 Time-Table for Experimental Groups (March 1970)

DATE	GROUP I	GROUP II	GROUP III
Mon. 2nd	Pre-Test (6)		
Tues 3rd	1 (3)		
Wed. 4th	2 (3)	Pre-Test (1)	
Th. 5th		1 (4)	Pre-Test ⁺¹ / ₂ (7)
Fri. 6th			1 (2)
M 9th	3 (6)		
T 10th			
W 11th	4 (3)	2 (1)	
Th 12th		3 (4)	2 (7)
F 13th			3 (2)
M 16th	5 (3)		
T 17th			
W 18th		4 (1)	
Th 19th		5 (4)	4 & 5 (7)&(8)
F 20th	Post-Test(5)	Post-Test (5)	Post-Test (5)

Key

Lesson in series in black

Teaching period in (brackets)

All groups were told that a test would be given at the end of the topic as is normal in these classes, and towards the end of instruction the test period was indicated.

Study time spent on the topic was not identical for all groups because no homework was set for Group I while homework was an integral part of the work in Groups II and III. The learning programme, however, was available for private study in Group I if required. Group I had 5 lessons, Group II 5 lessons and 5 homework periods and Group III 5½ lessons and 5 homework periods.

Where included homework is given during the lesson and is planned to be of 30 minutes duration. Evidence afforded by the programme response sheet indicated that all Group II spent this time working on the programme. It was not possible to check that all Group III had done the homework or how long they spent on it. No specific homework was set for Group I but many pupils borrowed the programmes for private study prior to the G.C.E. type test.

The Lessons

Group I worked through the learning programme at the rate of one section per lesson and pupils worked at their own speed within the lesson. Assistance was given only when requested. When each pupil had worked through the section they then attempted the section test on the answer sheet provided. These answer sheets were marked and returned to the pupils at the next lesson.

Group II worked through Section 1 of the programme during the first lesson to enable everyone to become familiar with the programme format and the learning programme technique. All subsequent sections provided homework sessions and section tests were marked as in Group I. The remaining four lessons were used to discuss programme content, to answer questions and to summarise the material presented.

In Group III the normal teaching method was used.

During the period of the experiment a number of pupils were absent on one or more days, Table 7.2 gives the details.

Table 7.2 Absentees from Experimental Groups (n 26 per group)

Lesson	Group I	Group II	Group III
1		3	1
2		1	1
3	1	1	2
4		1	
5	1	1	

In Group I there were two absentees but only one pupil failed to work section 5. In Group II there were 7 absentees - this resulted in 4 discussion lessons being missed and one pupil failing to work the final two sections of the programme. In Group III 4 lessons and homeworks were omitted. It appears that one of the advantages of the programme learning method is that absentees can study the learning material privately at a later date.

The post-test was given to all groups at the same time so that there was no possibility of conferring between groups. The test took place in three separate rooms with three supervisors. To reduce the effect of the examiner variable precise instructions were given to each pupil on a clearly typed question sheet. All groups were given thirty minutes uninterrupted time for the test. All pupils who completed this post-test are included in the experimental results.

Retention was tested approximately five weeks after instruction using the same examination procedure.

Because it was retention and not possible reinforcement which was to be tested the pupils were given no advance warning of this test.

Nine weeks after instructions a further test was given to all groups consisting of a) a G.C.E. theory question and b) a G.C.E. map interpretation question. The aim of this test was to examine the performance of each teaching method in the normal school situation. Pupils were told of this examination and its date in advance and to make the motivation as realistic as possible marks obtained were to be included in the end-of-year geography examination result. The learning programme, lesson notes, textbooks etc. were available to the appropriate groups for revision purposes.

Table 7.3 gives a summary of the experimental design.

Table 7.3 Experimental Design - Teaching Methods and Tests

Group	AH ₄	Pre-Test	Teaching Method	Post-Test	Retention	G.C.E.	O.S.
I	✓	✓	Programme only	✓	✓	✓	✓
II	✓	✓	Programme + discussion	✓	✓	✓	✓
III	✓	✓	normal method	✓	✓	✓	✓

Pilot Study

Ideally in an experiment of this nature a small pilot study is carried out in order to test the experimental materials and procedures and to provide statistics for a preliminary analysis.

In this study the shortage of time and suitable pupils did not permit such a study. The experimenter had, however, knowledge of the learning programme gained in the validation stage of programme development and had given lessons on glaciation at this level on a number of occasions. Experience in the difficulties and problems posed by a comparative teaching methods experiment had been obtained in previous work¹.

(c) Assessment of the learning programme

A summary of the effectiveness of the learning programme as illustrated by the final validation data gives a post-test gain ratio of 1.43 with a retention gain ratio of 0.9, for glaciation theory. This indicates that substantial learning had occurred and that much of the material had been retained after a period of one month. The map interpretation of glacial highland features indicated a much lower post-test gain (0.75) and a much lower retention gain (0.56) and this part of the learning programme was considered to be unsatisfactory. For this reason the comparative experiment concentrates on glaciation theory.

(d) Description of the Measuring Instruments used in the Experiment.

(i) General Intelligence Ability

The General Ability of all pupils was obtained by using the AH₄ Group Test of General Intelligence.

1 Elizabeth Shepherd (1968) 'Some aspects of the usefulness of television as a teaching medium, with particular reference to the study of Geography'. Unpublished thesis Dip.Sec.Ed. Cambridge Institute of Education.

The reliability of this test, measured on a test-retest basis, is reported as being 0.9 (A.W.Heim 1967). An estimate of the validity of the test based on correlation with similar tests is 0.6.

(ii) Achievement tests

Post-test and retention attainment were measured by an objective type test (Brown 1966). This test covers a large number of points and no overlapping occurs. The questions require precise answers and can be accurately marked.

The reliability of this test was calculated by the test-retest method with the scores of all pupils completing the post-test and retention test providing the data. The correlation of 0.89 is significant ($p < .01$). The objective test design facilitates the construction of a valid test. This is an achievement test carefully written to examine a detailed programme/lesson content.

(iii) G.C.E. questions

The theory and map reading questions are based on questions set by the Northern Joint Board. This examination is more subjective in nature. Items tested cover a much smaller sample of the programme/lesson content and the pupil is required to give essay type answers.

(e) Statistical Analysis Techniques used in the Comparative Study.

The following statistical methods have been used in the analysis of data obtained from the study.

(i) Standard deviation with small samples S.D. = $\sqrt{\frac{d^2}{N-1}}$

(ii) (a) Calculation of correlation coefficients
by using Bravais Pearson formula

$$r = \frac{\sum xy}{\sum x^2 \cdot \sum y^2}$$

or (b) a Bivariate Frequency Distribution¹

$$r = \frac{N \sum x'y' - \sum fx' \sum fy'}{\sqrt{[N \sum fx'^2 - (\sum fx')^2][N \sum fy'^2 - (\sum fy')^2]}}$$

(iii) Student's t for the comparison of the difference
between two mean scores:

$$t = \frac{\bar{x}_1 - \bar{x}_2}{\sqrt{\frac{\sum d_1^2 + \sum d_2^2}{n_1 + n_2 - 2} \left(\frac{1}{n_1} + \frac{1}{n_2} \right)}}$$

(iv) Simple Analysis of Variance is used to test the
significance of the differences between the mean scores
obtained in the three teaching groups at various stages.
The formula² used results in the F ratio.

(f) Degree of Generalisation

The comparative experiment was carried out by one
teacher in one school. Lindquist (1940) points out
that any conclusions drawn from a methods experiment
in one school are strictly applicable to only that school.
The reason for this is that pupil performance depends
upon the previous experience of the pupils - the previous
teaching method used or the study habits required by the
pupils may have been similar.

1 Ferguson (1959) page 95

2 Ferguson (1959) page 237

It is felt, however, that because the pupils taking part in this experiment had recently transferred to the school from four Junior High Schools where they had been taught by a number of teachers in a variety of teaching groups, the results obtained have a wider application than is normal in this type of study.

Chapter 8 PROGRAMME EVALUATION II - STATEMENT AND
DISCUSSION OF RESULTS

Control Variables

Measures of General Intelligence and previous knowledge of the topic of glaciation were taken so that the results, as shown by the criterion tests in the three teaching groups, could be equated. All test results obtained in the comparative experiment are recorded in Appendix (xiii).

The mean General Intelligence scores for the three teaching groups were compared. An analysis of variance computation is shown in Table 8.01; this gives a no significant difference result at the 5% level.

Table 8.01 Analysis of Variance - General Intelligence (n 78)

Source of Variance	Variance	degrees of freedom	mean square
Between groups	508.04	2	254.02
Within groups	12704.55	75	169.39
Total	13212.74	77	

$$F = 1.5$$

$$df \begin{matrix} 2 \\ 75 \end{matrix}$$

$$p > .05$$

The analysis of the pre-test scores for the three teaching groups yielded a similar result as shown in Table 8.02.

Table 8.02 Analysis of Variance - Pre-test Scores (n 78)

Source of Variance	Variance	degrees of freedom	mean square
Between groups	8.84	2	4.42
Within groups	522.47	75	6.97
Total	532.24	77	

$$F = 0.63$$

$$df \begin{matrix} 2 \\ 75 \end{matrix}$$

$$p > 0.05$$

Because the mean General Intelligence score and pre-knowledge scores were not significantly different in the teaching groups it was considered that the groups were equivalent for the purpose of this study.

As indicated in Chapter 6 the learning resulting from programme study in the validation of the programme was considered to be at an acceptable level with the exception of the Ordnance Survey map interpretation. In this experiment map interpretation is included only at the final stage and will be studied independently.

Criterion Variables

A comparison is made in each group between the mean pre-test score and the mean post-test score (Student *t*) to find out if learning did occur in all groups. The results of this analysis appear in Table 8.03. These results show that significant learning occurred in all groups. The three teaching methods chosen for this experiment were all effective in producing significant gains in the experimental population.

Table 8.03 Comparison of Pre- and Post-test Results
within each Teaching Group

Group I	t = 11.11	p < .01
Group II	t = 11.05	p < .01
Group III	t = 13.94	p < .01

Following from this the investigation sought to discover if any one of these teaching methods was more effective than the others. To this end the pre-test scores were subtracted from the post-test scores to give a learning gain score for each pupil. The resulting figures, recorded in Table 8.04, show that programme plus discussion yielded the highest total scores and programme only the lowest total scores for the three teaching groups.

Table 8.04 Post-test Gains for the three Teaching Groups

(n 78)

Group	Total Score	Mean Score	Standard Deviation
I	391	15.04	5.94
II	439	16.88	6.38
III	416	16	4.86

These figures were used in a simple analysis of variance computation. The F ratio of 0.66 gives no significant difference between the mean scores of the teaching groups at the 5% level, as shown in Table 8.05. It would seem that the additional time spent in discussion in Group II did not significantly increase the level of learning above that achieved by Group I.

The additional time spent in Group III appears to have been necessary to effect the same level of success as in the programme only group, Group I. It would appear that this is a less efficient method of teaching this particular subject matter. This result is similar to that recorded for 22 of the 49 experimental results summarised by Hartley (1966).

Table 8.05 Analysis of Variance - Post-Test Gains (n 78)

Source of Variance	Variance	degrees of freedom	mean square
Between groups	43.94	2	21.97
Within groups	2489.91	75	33.20
Total	2533.98	77	

$$F = 0.66$$

$$df \begin{matrix} 2 \\ 75 \end{matrix}$$

$$p > 0.05$$

In an attempt to see if any of the teaching methods favoured the more or less intelligent, the students were divided into an upper and lower ability range for each teaching group. These results were analysed within each group and for the whole population. The mean score gain results are recorded in Table 8.06.

Table 8.06 Mean Post-Test Gain Scores for two Ability Grades in three Teaching Groups

AH4	Group I	Group II	Group III	Total
Above 80	16.93	18.2	17.17	17.35
0 - 80	12.45	16.06	15.00	14.73

These figures indicate that the more intelligent pupils achieved a higher mean score whichever teaching method was used. The t_1 test was used to compare the mean scores of the upper and lower intelligence divisions within each teaching group and for the whole population. The mean scores within each group were not significantly different, but for the total population the figure is significant at the 5% level.

Table 8.07 A comparison of Gain Scores for two Ability Grades in three Teaching Groups.

Group I	Group II	Group III	Total
t = 2.034	t = 0.8271	t = 1.142	t = 2.056
df 24	df 24	df 24	df 76
p > .05	p > .05	p > .05	p < .05

A correlation between intelligence and achievement as shown by post-test gain scores exists and is significant at the 1% level in all groups.

<u>Group I</u>	<u>Group II</u>	<u>Group III</u>
0.776	0.6567	0.7543

Some five weeks after the completion of instruction the same criterion test was completed by all groups. The pupils were not told in advance about the test so that the scores achieved gave a measure of the retention of the learning which had occurred. This retention score minus pre-test score gave the retention gain score used in the next computation.

Table 8.08 Analysis of Variance - Retention Test Gains(after 5 weeks) (n 73)

Source of Variance	Variance	df	mean square
Between groups	155.27	2	77.63
Within Groups	2015.45	70	28.79
Total	2170.99	72	

$$F = 2.697 \quad \begin{matrix} 2 \\ df70 \end{matrix} \quad p > 0.05$$

The results show that there is no significant difference between the mean scores in the three teaching groups for retention. Each teaching method was equally successful for the criteria tested five weeks after instruction. This result is similar to that recorded in 17 of the 19 comparative experiments carried out in schools and listed by Hartley (1966).

It is, however, more normal in the teaching situation for pupils to be tested at the end of the school year or at the end of the G.C.E. course. Pupils are then aware of the event and most revise work covered using their text or their own work record. Because of the different teaching methods used the amount and type of material available for this revision work differed in the groups. It was thought that the programme only group might be at a disadvantage because their revision material consisted of a rather lengthy learning programme only. The final test in this study was designed to test the performance of the various teaching methods in this situation and was given nine weeks after study. This time a G.C.E.

type question was used to test (i) theory; (ii) map interpretation.

Table 8.09 Analysis of Variance - G.C.E. glaciation theory
(after 9 weeks) (n 72)

Source of Variance	Variance	df	mean square
Between groups	89.14	2	44.57
Within groups	1528.83	69	22.16
Total	1617.78	71	

$$F = 2.01 \quad df \begin{matrix} 2 \\ 69 \end{matrix} \quad p > 0.05$$

Again a no significant difference result was obtained for the theory examination. Any difference in the mean scores which did exist could have been the result of sampling error.

Table 8.10 Analysis of Variance - G.C.E. map interpretation
(after 9 weeks) (n 72)

Source of Variance	Variance	df	mean square
Between groups	12.38	2	6.19
Within groups	159.58	69	2.31
Total	171.96	71	

$$F = 2.68 \quad df \begin{matrix} 2 \\ 69 \end{matrix} \quad p > 0.05$$

The result of the analysis of variance for the data provided by the map interpretation criterion test is, at first sight, surprising. This section of the learning programme was unsatisfactory at the developmental stage of programme construction.

A significant result in favour of traditional teaching methods seemed the logical expectation. In fact this was not the case. None of the teaching methods used in the experiment was more successful than the others. The reason for the comparative failure of all methods here probably arose because the pupils lacked the necessary skills to interpret contour maps. It may be that the thirteen to fourteen age group is too early to study map interpretation or that girls have particular difficulties with it.

A survey of the literature gives little conclusive evidence on this point. Long and Roberson (1966) include map interpretation of physical features in a proposed scheme of work for third and fourth year grammar school pupils. Brown (1960) summarised an investigation into the problems of teaching map reading. He suggests that map interpretation of physical features presents the hardest task to the teacher and is doubtful whether it should be attempted before the age of fourteen. Boys were better than girls at map reading generally between the ages of twelve and fourteen. It is possible that the comparative failure to teach map reading by any of the teaching methods used in the evaluation experiment may be explained in this way.

The evaluation experiment illustrates, however, that the learning programme developed in this study was able to teach the criteria chosen for comparison as effectively as the normal teaching procedure and requires less time to do so.

The learning programme can also be used effectively with other teaching methods as illustrated in Group II.

It must be remembered, however, that the programmed learning method was new to the pupils using it and their results may have been enhanced by the Hawthorne effect. All groups were aware that they were taking part in a teaching experiment and it is probable that the marks in all groups were affected in this way to some extent.

It is possible that after the initial interest shown in programmed learning pupils would become less interested if the method were used exclusively over an extended period of time. If the learning programme could not sustain pupil interest a drop in the achievement level would result.

It is true that many pupils prefer to work alone and at their own pace but many others appear to respond better to group involvement. Some teachers argue that social interaction is an essential component of learning. If used along with others forms of instruction programmed learning can make a significant contribution to the learning scene. In this experiment the programme used proved to be as effective in achievement and more economical in time than the teaching method normally used in the school for the criteria tested.

It appears that if a suitable learning programme is available the teacher should consider using it in any scheme of work being prepared.

The programme will be suitable if its contents and objectives are those required by the teacher and the programme has been validated for use with pupils of the same age and ability range.

Programmes which fit these requirements are not, however, always readily available. At the outset of this enquiry there was only one programme on glaciation at 'O' Level and this was unsuitable because the content material in sections 3, 4 and 5 of this study was omitted. The programme¹ had also been developed for use with 16+ examination candidates drawn from secondary modern schools. Since then another programme² has been developed for the 13-15 age range but this time no ability range is indicated. In both these programmes no indication is given of anticipated performance levels.

1 G. Hitchen (1965) Glaciers. Wiltshire (Linear, 120 frames, 2½ hrs).

2 M.R. Clayton (1967) The Work of Ice. Packman (Linear, 57 frames, 55 minutes).

SUMMARY and CONCLUSIONS

To sum up, the aim of the study was to write a learning programme in geography for prospective 'O' Level examination candidates and to validate and evaluate the learning programme produced.

Glaciation was chosen from the school syllabus as a suitable topic for programming because of the stability of the content material and the estimated time requirement. The programme was developed for use in the school situation and it satisfies the examination requirements of the Joint Matriculation Board.

A linear programme with overt response was considered to be most appropriate because the material to be taught to the above average ability 13+ - 14+ pupils was unfamiliar and factual.

The final version of the learning programme consists of 144 frames grouped into five sections. A number of Panels making use of accounts, maps, photographs and an Ordnance Survey map are included. Each section can be worked in a lesson period of 35 - 40 minutes. Pupils work at their own pace within these limits and enter their responses on prepared work sheets. Each section ends with a section test.

The final version of the learning programme is a result of analysis of the learning effects produced at the various stages of programme development. The pupils who assisted in programme development attended a 13 - 18 Girls High School.

Four stages were found to be necessary in the validation process before the criterion for success (Gain Ratio of 1.2) was achieved. Programme revisions were based on pupil performance in the post-test. Where a test item indicated failure in a teaching point (less than 70% success) the test question was checked and this was followed by an analysis of key frame response errors and the sequence of frames leading to the key frames. In general a key frame error rate of less than 5% and an overall error rate of less than 10% was sought. The final programme revision was also based on a chart which recorded the structure of the penultimate programme. This chart records the number and position of teaching points in each section; the function of each frame; the type of prompt used and the method of linking teaching points.

In the final validation an overall Gain Ratio of 1.38 was recorded. Frame response errors of 6.92% for key frames and 5.8% overall were obtained.

The learning programme consists of four sections dealing with the theory of glaciation and one section with the map interpretation of glacial features. The theory of glaciation taken as a unit results in a Gain Ratio of 1.43 with frame response errors of 4.71% and 4.6% respectively. The map interpretation Gain Ratio was 0.75 and frame response errors 19.11% and 13.59%.

The latter was considered to be unsatisfactory and it was suggested, at this stage, that the pupils concerned in programme development lacked the basic map reading skills necessary for this kind of exercise.

A complete programme Gain Ratio of 0.87 was recorded for retention of learning after a period of one month.

The learning programme was then used in a teaching methods experiment so that its performance could be compared with the method of instruction normally used in the school. Pupils were randomly allocated to three teaching groups. The teaching methods were:- learning programme only; learning programme plus discussion and the normal teaching method. All groups showed significant gains in the post-test. A number of comparisons were made between the mean scores of the three groups:- (i) post-test gains (ii) retention gains (5 weeks later); (iii) G.C.E. theory (9 weeks later); (iv) G.C.E. Map interpretation (9 weeks later). In all these computations a result of no significant difference was obtained.

The general conclusion is that the learning programme developed in this study was as effective in teaching the topic of glaciation as the teaching method normally used in the school in which the experiment took place for the criteria tested and in fact did so in less time.

An interesting point which emerged from the enquiry related to the problem of teaching map interpretation to the 13 - 14 year old age group. After four revisions the map reading section of the learning programme did not reach an acceptable level of success, yet the

comparative experiment illustrated that this section of the learning programme was as effective as the normal teaching method. It may be that the comparative failure in this area is a result of the lack of maturity on the part of the pupils concerned rather than an inherent fault in the teaching materials or methods used. Further investigation is necessary to clarify the reason for failure here.

BIBLIOGRAPHY

- AUSTWICK, K.(Ed.)(1964). Programming '64.Bull.Res.Unit,
Dept.Ed.,University, Sheffield.
- BECKER, James L.(1964) A programmed Guide to writing
Auto-Instructional Programs. Camden, N.J.:
Radio Corporation of America.
- BERGLUND, Gosta W.(1969). The Effect of Partial Reinforcement
in Programmed Instruction. Programmed Learning, 6
102-108.
- BJERSTEDT, Åke(1965) Mapping of Effect Structure of Self-
Instructional Materials. Programmed Learning, #2,
99-109.
- BJERSTEDT, Åke(1967) Mapping the Pheno-Structure of Self-
Instructional Materials. Programmed Learning, 4,
87-102.
- BLAKE, C.S.(1966) A Discussion on Program Data,
mimeographed and privately circulated.
- BLAKE, C.S.(1967) A procedure for the initial evaluation
and analysis of linear programmes in Aspects of
Technology, Ed. Derick Unwin and John Leedham, Methuen.
- BROWN, James(1966) Objective Tests: Their construction
and analysis. Longmans.
- BROWN, T.W.(1960) Geography, 45, 305-306.
- BUCKLAND, P.R.(1967) The Response in a Linear Program:
Its Mode and Importance. P.Learning, #4, 47-51.
- CALLENDER, Patricia (1969) Programmed Learning: Its
Development and Structure. Longmans.

- COULSON, J.E. and SILBERMAN, H.F.(1960) Effects of three variables on a teaching machine. *J.Educ. Psychol.* 51, 135-43.
- CROWDER, Norman A. (1960) Automatic Teaching by Intrinsic Programming, in Lumsdaine, A.A. and Glaser, Robert Teaching Machines and Programmed Learning: A Source Book, D.A.V.I., N.E.A., Washington D.C.
- DANIEL, W.J. and MURDOCK, P.(1968) Effectiveness of learning from a Programmed Text compared with conventional text covering the same material. *J.Ed.Psych.* 59, 425-431.
- DODD, B.T.(1965) Programmed Construction - A Symposium. 4. Structuring Subject Materials. *Programmed Learning* 2, 88-93.
- DUNCAN, Charlotte and HARTLEY, James (1969) The Effects of Mode of Presentation and Recall on a Simple Learning Task. *Programmed Learning*, 6, 154-158.
- EIKEBOOM, R. (1969) The application in a programmed Latin grammar of some data from learning psychology, in *Aspects of Educational Technology*, ^{Vol. 2.} Ed. Dunn, W.R. and Holroyd, C. Methuen.
- ELLEY, W.B. (1966) The Role of Errors in Learning with Feedback, *B.J.Ed., Psy.*, 36, 296-300.
- ESPICH, James E and WILLIAMS, Bill (1967) Developing Programmed Instructional Materials: A Handbook for Program Writers. Fearnon, California.
- EVANS, James, GLASER, Robert and HOMME, Lloyd (1960) The RULEG System for the Construction of Programmed Verbal Learning Sequences, Dept. of Psy., Univ. of Pittsburgh.

- EXAMINATIONS BULLETIN No: 3 (1964) The Certificate of
Secondary Education: An introduction to some
techniques for examining. H.M.S.O.
- FERGUSON, George A. (1959) Statistical Analysis in
Psychological Education. McGraw-Hill.
- FRANKLIN G.S. (1964) Preparation of programmed instruction
Mimeographed and privately circulated.
- GILBERT, Thomas F. (1962) Mathetics: the technology of
education. Journal of Mathetics, 1, 7-73.
- GOLDBECK, R.A. and CAMPBELL, V.N. (1962) The effects of
response mode and response difficulties on
programmed learning. J. Educ. Psychol, 53, 110-118.
- GOLDSTEIN, L.S. and GOTKIN, L.G. (1962) A Review of Research -
Teaching Machine versus Programmed Textbooks as
Presentation Modes, J.Pr.Instruction, 1, 29-36.
- HARTLEY, J. (1964a) A Study of Programmed Learning. Ph.D.
Thesis Univ. of Sheffield.
- HARTLEY, J. (1964b) The functional analysis of frames:
a proposed system. Mimeographed and privately
circulated.
- HARTLEY, J. (1966) Some Guides to evaluating programmes.
in Programmes in Print ed. Cavanagh, P. and Jones, C.
Assoc. of Prog. Learning, London.
- HARTLEY, James (1968) Some Factors affecting Student
performance in programmed learning.
Programmed Learning, 5, 206-218.
- HARTLEY, James and FRANKLIN, G.B. (1965) The Function and
Analysis of Frames: Proposed System.
Programmed Learning, 2, 93-99

- HEIM, A.H.W. (1967) Group Test of General Intelligence. Nat. Foundation for Ed. Research.
- HERRINGSHAW, Pauline E. and HUNTER, J.H. (1964) Geography: Branching versus Linear Programming. Ed.Rev., 16, 109-119.
- HOLLAND, James G. (1960) Programming Verbal Knowledge, Harvard Psy. Laboratories, Cambridge, Mass.Mimeo.
- HOPE, Barbara F. (1969) Programmed Instruction: An experiment with programmed text: self-pacing versus group pacing. M.Ed. thesis, Univ. of Durham.
- JACOBS, P.I., MAIER, M.H. and STOLUROW, L.M. (1966) A Guide to Evaluating Self-instructional Programs. Holt, Rinchart and Winston.
- KAY, Harry, DODD, Bernard and SIME, Max.(1968a) Teaching Machines and Programmed Instruction. Pelican A916.
- KAY, Harry, (1968b). Programmed Instruction in Ed. H.J. Butcher Education Research in Britain. University of London Press.
- KLAUS, David J. (1960) Some Observations and Findings from Auto-Instructional Research. Am.Inst. for Research, Pittsburgh.mimeo.
- KRUMBOLTZ, J.D. (1964) The nature of importance of the required response in programmed instruction. American J.Ed.Res., 1, 203-209.
- KRUMBOLTZ, J.D. and WEISMAN, R.G. (1962) The effect of overt v. covert responding to programmed instruction on immediate and delayed retention. J.Ed.Psy; 53, 89-92.

- LARKIN, T.C. (1964) A comparison of branching and linear methods of programming elementary science. *Educ.Rev.*, 6, 92-98.
- LARKIN, T.C. and LEITH, G.O.M. (1963) A comparison of Linear and Branching methods of Programmed Instruction. *Programming '63.*, Ed.Dpt.Univ. of Sheffield.
- LEEDHAM, J. and UNWIN, D. (1965) *Programmed Learning in Schools.* Longmans.
- LEITH, George (1966a) Developments in Programmed Learning in *Trends in Education*, 2, 20-26.
- LEITH, G.O.M. (1966b) *A Handbook of Programmed Learning.* Ed.Rev.Occ.Publication No: 1. University of Birmingham.
- LEITH, G.O.M. (1969) *Second thoughts on Programmed Learning.* Nat.Council for Ed. Research.
- LEITH, G.O.M. and BURKE, K.M. (1967) *Mode of Responding and Redundancy.* *Programmed Learning*, 4, 10-15.
- LEITH, G.O.M. and CLARKE, D.W. (1967) *Transfer as a function of task variation.* Research Report No: 22. N.C.P.L.University of Birmingham.
- LEITH, G.O.M. and EASTMENT, D.E.(1970) *A Study of Prompting versus Confirmation in Machine and Text Presented Programmed Learning under Two Conditions of Responding.* *Programmed Learning* , 7, 13-20.

- LEITH, G.O.M. and GHUMAN, A.S. (1967) The effects of prompting and confirmation on two methods of responding to a self-instructional programme. *Programmed Learning*, 4, 15-19.
- LEITH, G.O.M. and HOPE, B. (1965) A Comparison of Two Methods of Responding to Linear and Branching Programmes. *Ed.Rev.* 17, 223-233.
- LEITH, G.O.M. and WISDOM, B. (1967) A further study of relationships between errors, attainment and personality. Research Report No: 29, N.C.P.L. University of Birmingham.
- LEYTHAM, G.W.H. (1970) Learning and Teaching. *Br.J.Ed.Psy.*, 40, 90-93
- LEWIS, D.G. and GREGSON, A. (1965) The Effects of Frame Size and Intelligence on Learning from a linear Programme. *Programmed Learning* 2, 170-175.
- LINDQUIST, E.F. (1940) *Statistical Analysis in educational research*, Boston, Houghton.
- LONG, M. and ROBERSON (1966) *Teaching Geography*. Heinemann.
- MAGER, Robert F. (1962) *Preparing Instructional Objectives*. Fearon. California.
- MARKLE, Susan M. (1963) The Lowest Common Denominator: Persistent Problem in Programming. *Prog.Inst.*, 2.
- MARKLE, Susan M. (1964) *Good Frames and Bad*. Wiley.
- MECHNER, F. (1961) *Programming for Automated Instruction*. N.Y., Basic Systems, Inc. mimeo.

- MIDDLETON, R.G. (1964) The effects of size of step on programmed learning using a spelling programme. Ed. Rev. 16, 99-108.
- MILLS, G.M. (1969) An Analysis of Response Errors in the Evaluation of a Technical Teaching Programme. Programmed Learning, 6, 121-132.
- MOORE, D.L. (1967) Group Teaching by Programmed Instruction. Programmed Learning 4, 37-46.
- MORGAN, R.M. and DUBOIS, B.L. (1965) How many frames to teach? Programmed Learning, 2, 46-50.
- MORRIS, S. (1965) The Development and Evaluation of a Programmed Latin Course. Nat. Centre for Programmed Learning Report.
- ORR, W.C. (1968) Retention in Comparing Programmed and Conventional Instruction Methods. J. Ed. Res., 62, 11-13.
- PAVLOV, I.P. (1927) Conditioned reflexes. London O.U.P.
- PIKAS, Anatol (1967) Comparison between traditional and Programmed Learning as a function of the comparison test. Programmed Learning, 4, 270-283.
- PIPE, Peter (1966) Practical Programming. Holt, Rinehart and Winston Inc.
- POPP, R.J. and McGUIGAN, F.J. (1963) Biological Basis of Behaviour, Instructor's Manual. Prentice Hall, New Jersey.
- PRESSEY, Sidney L. (1926) A Simple Apparatus which Gives Tests and Scores - And Teaches. School and Society, 23, 373-376

- ROBSON, G.A. and AUSTWICK, K. (1965) A comparison of two modes of presentation of a linear constructed-response programme. *Prog. Learning* 2, 31-36.
- ROBBINS, (1963) Higher Education: report of the Committee on Higher Education. H.M.S.O.
- ROE, A.A. (1962) A comparison of branching methods for programmed learning. *J.Ed.Res.* 55, 407-416.
- ROEBUCK, Martyn (1970) A Definite Conclusion in a Comparison between Conventional and Programmed Instruction. *Programmed Learning*, 7, 21-23.
- ROWNTREE, D. (1969) Tutorial programming - an integrated approach to frame writing in *Aspects of Technology Vol.2*. Ed.W.R.Dunn and C. Holroyd. Methuen.
- SAWIRIS, M.Y. (1966) An Experimental study of Individual and Group Learning using a Linear Geometry Programme. *Programmed Learning*, 3, 146-153.
- SKINNER, B.F. (1954) The Science of Learning and the Art of Teaching. *Harvard Ed. Review*, 24, 86-97.
- SKINNER, B.F. (1958) Teaching Machines. in *Teaching Machines and Programmed Learning: a source book*. Ed.Lumsdaine, A.A. and Glaser, R.(1960)
- SMITH, K.V. and SMITH, M.F. (1966) *Cybernetic Principles of Learning and Educational Design*. N.Y. Holt, Rinehart and Winston.
- STOLUROW, L and BEBERMAN, M. (1962) Comparative Studies of Principles for Programming Mathematics in Automated Instruction. Report No: 4. University of Illinois.

- STONES, E. (1968) Strategy and Tactics in Programmed Instruction. Programmed Learning, 5, 122-128.
- TABER, J.I. GLASER, R and SCHAEFER, H.H.(1965) Learning and Programmed Instruction. Addison - Wesley.
- THOMAS, C.A. et al. (1963) Programmed Learning in Perspective. London. City Publicity Services.
- THORNDIKE, E.L. (1911) Animal intelligence. N.Y. Macmillan.
- WALLIS, D. DUNCAN, K.D. and KNIGHT, M.A.G. (1966) Programmed Instruction in the British Armed Forces. H.M.S.O.
- WALLIS, D. and WICKS, R.P. (1964) The Auto-tutor and classroom instruction: The Royal Navy Study. Programmed Learning, 1, 31-47.
- WIDLAK, P. (1964) The Effects of mode of response on learning. Ed. Review., 16, 120-129.
- WHALLEY, Noel (1966) A Guide to the Preparation of Teaching Programmes. Bristol.

Appendix (i)G.C.E. 'O' Level questions on glaciation (1963-70.)

June 1970 3. Each of the following processes can create landscape features: coral accumulation; glacial deposition; wind deposition; volcanic action. Choose three of these processes and for each; (i) with the aid of diagrams describe one landscape feature which has resulted from the process and give reasons for its development; (ii) name a locality where such a landscape feature may be found.

June 1968 3. Steep-sided valleys can be formed in a variety of ways. (i) Describe with the aid of diagrams THREE different ways in which they can be formed; (ii) in each case name and locate an example.

November 1967 4. Study the photographs (one of these was of a U-shaped valley, with hanging valley and ribbon lake). Describe how the relief features shown on each photograph have been formed.

November 1966 3. Choose TWO of the following: a limestone upland, a glaciated lowland, a river flood plain, a sand desert. For each of the two you have selected (i) with the aid of diagrams, describe and give reasons for the characteristic features of the relief and drainage of such an area; (ii) name and locate an example.

June 1966 3. Choose THREE of the following processes of landscape formation: glacial erosion, wind deposition, volcanic action, coastal erosion, limestone solution.

(a) Name ONE feature produced by each of the processes you have selected and identify a locality where such a feature may be found. (b) With the aid of diagrams describe and give reasons for the characteristics of the features you have named.

November 1965 3. Select THREE of the following: an atoll, a delta, a hanging valley, an ox-bow lake, a volcanic cone. For EACH (i) describe with the aid of diagrams how such a feature has been formed; (ii) locate a particular example.

June 1964 3. Select two of the following: an arête, a chalk escarpment with a spring line, a ria coastline, a gorge with a waterfall, a glaciated valley. For each (i) draw a contoured sketch map to illustrate its characteristic features; (ii) explain, with the aid of diagrams, how it has been formed; (iii) name and locate an example.

June 1963 3. Select three of the following: an atoll, a corrie, a haff, a rift valley, a volcanic cone. For each (i) state the location of a particular example; (ii) describe, and illustrate by diagrams, how such a feature has been formed.

Appendix (ii)

Learning programme section tests used as pre-test, post-test and retention test. (Final Version)

In Section 4 questions 1, 2 and 3 test pre-requisite knowledge and are given in the pre-test only.

TEST 1

Answer all questions.

1(i) A thick layer of ice and snow which covers a large lowland area is an _____.

(ii) One of these can be found in _____.

2 What is a nunatak?

3(i) What is an iceberg?

(ii) Why is it impossible for ships to see most of it?

4 In cold mountainous areas permanent snow collects in large areas called _____ and much smaller depressions (hollows) called _____.

5 Name a mountain range which has permanent snow.

6 The snow may fall quickly from the mountain side as an _____ or move much more slowly, in the form of ice, as a _____.

TEST 2

Answer all questions.

1 The ice within a glacier does not move at the same speed. The ice near the _____ moves slowest because _____.

2 a) Sometimes large cracks, called _____, form on the surface of the ice.

b) These cracks may be caused by i) _____
ii) _____

- c) The pinnacles of ice, between the cracks, are _____.
- 3 The loose rock, which falls onto the glacier from the mountain peaks, is called _____. When it is carried along the sides of the glacier it is a _____.
- 4 Name a river which starts as a glacier.
- 5 Draw a clear diagram to show how a moraine-dammed lake is formed. Label your diagram.
- 6 Give an example of a moraine-dammed lake.

TEST 3

Answer all questions.

- 1 Name a highland area in Britain which has been glaciated.
- 2 The main work of the ice, in a highland area, is to _____ the surface.
- 3a)(i) Describe a corrie
(ii) Draw a labelled diagram to show how it was formed.
(iii) Give an example.
- b) What is an arête?
- c) Where are corries and arêtes found in these highland areas.
- 4a)(i) What is the main valley in a glaciated highland area called?
(ii) How does it differ in shape from a normal river valley?
- b) Label the three features indicated on this diagram.
- c)(i) Describe a ribbon lake.
(ii) Give one example.



TEST 4

Use the O.S. map of part of the Snowdon District for this test. The map is on page 53 or 58 in Margaret Wood - Map Reading for Schools. (Part of this map was masked so that pupils were restricted to the area south-west of northing 60 and easting 63).

- 1 Name the lake in grid square 6459.
- 2 Llyn Ogwen is the largest lake on this map. In which direction from Llyn Ogwen is the smallest lake Llyn y Cwn?
- 3

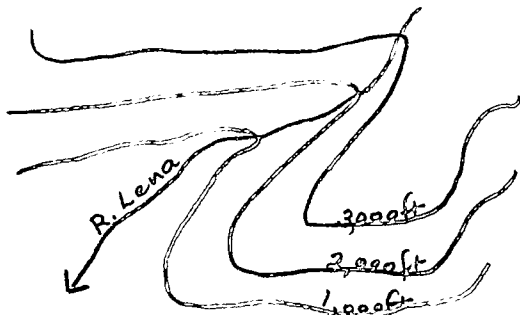

- a) Name the river shown on this contour map.
- b) The highest land shown on this map is over _____ feet.

- 4 Find evidence, from the map, which suggests that this area of Wales has been glaciated, by giving one named example of each of the following features: arête, corrie, U-shaped valley, hanging valley, ribbon lake. State clearly which is which.

TEST 5

Answer all questions.

- 1 What is an Ice Age?
- 2 The work of the ice in a lowland area is to _____.
- 3 As a result of glaciation, much of lowland Britain is covered with _____.
- 4(i) Eskers are common in _____.
(ii) Describe an esker.
(iii) How were eskers formed?
- 5(i) Describe a drumlin.
(ii) Name one area where drumlins can be found.
- 6 Large boulders, carried by the ice and deposited many miles from their point of origin, are called _____. A number of these can be found in _____.

Learning programme section test answers and marking scheme

TEST 1 (1 mark each - total 10).

- 1(i) ice sheet
- (ii) Greenland (Antarctica)
- 2 definition of a nunatak.
- 3(i) " " an iceberg
- (ii) only 1/10th or 10% is visible
- 4 snowfields
- corries
- 5 Alps (or any other)
- 6 Avalanche
- glacier

TEST 2 (1 mark each + 4 additional for diagram - total 15)

- 1 sides
- friction
- 2 a) crevasse
- b)(i)widening
- (ii) steepening } of the valley
- c) séracs
- 3 moraine
- lateral moraine
- 4 Rhine (or any other)

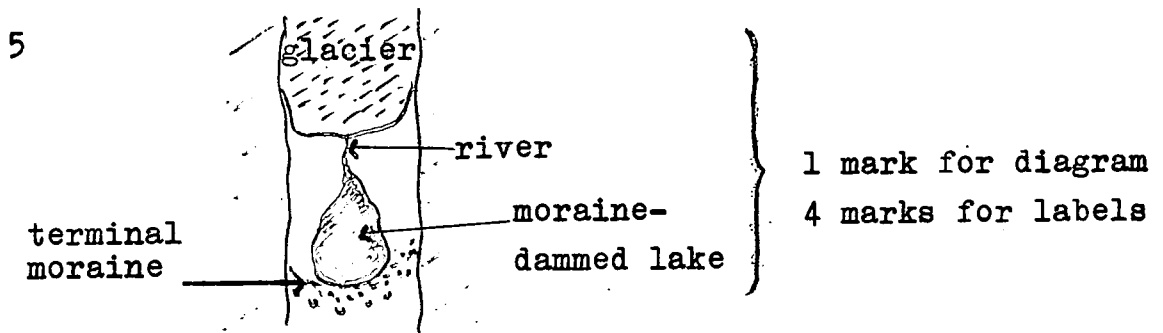

- 6 Windermere (or any other)

TEST 3 (1 mark each + 1 additional mark for 3a)(ii)-total 15)

1 A glaciated highland in Britain.

2 erode

3a)(i) circular with steep sides and flat base

(ii)



(iii) Blea Tarn (or any other)

b) razor-edged ridge

c) near the top

4a)(i) U-shaped

(ii) U-shaped instead of V-shaped.

b) 1 ribbon lake or river; 2 hanging valley; 3 waterfall

c)(i) long thin lake in the bottom of a U-shaped valley

(ii) Haweswater (or any other)

TEST 4 (1 mark each - total 5)

One example each, from the map, of:- arête, corrie, U-shaped valley, hanging valley, ribbon lake.

TEST 5 (1 mark each - total 10)

1 Definition of Ice Age

2 deposition

3 boulder clay

4(i) Sweden (or any other)

(ii) low ridges made of sand and gravel

(iii) the meltwater resorted the moraine as the ice sheet decayed.

5(i) small rounded hills made of moraine

(ii) Co. Down; Northern Ireland (or any other)

6 erratics

Austwick district of the Pennines (or any other)

Appendix (iii)

A Learning Programme in Geography

GLACIATION

by

E. SHEPHERD

(in envelope inserted in back cover)

QUESTIONNAIRE

Appendix (iv)

Name _____

Your answers are required for research purposes only.
They are strictly CONFIDENTIAL.

Enter your answers on this sheet. Tick where appropriate.

- 1 Do you think that you learned more or less about glaciation, using the programmed learning method, than you would have done with your usual teaching method?

much more	
more	
the same	
less	
much less	

- 2 Do you prefer this method of learning than your more usual lesson?

Tick one
of
these →

much less	
less	
the same	
more	
much more	

- 3 What do you like most about the programmed learning method?

What do you like least about the programmed learning method?

- 5 Can you suggest anything which would make the new method:-
(i) more effective (i.e. you would learn more or more-easily learn more easily or more quickly) _____

(ii) more interesting? _____

- 6 Arrange the following subjects in your order of preference, by entering 1 next to the subject you like best, 2 the next best, and so on.

Biology	
Chemistry	
English	
French	
Geography	
History	
Latin/Cl. Studies	
Mathematics	
Religion	
Spanish	
Physics	

Appendix (v)Learning Programme - First Version

This version of the learning programme was used in the first stage of programme validation - the preliminary trial. The five sections (149 frames) of the learning programme were worked by four pupils during five sessions. Each frame of the programme is printed separately with the confirmation on the reverse. Pupils entered their response to each frame on a prepared answer sheet before checking the correctness of their response. At the end of each session a section test was worked. No pre-test was given at this stage.

Individual student progress was observed during each session and students were asked to comment on their reactions to the work and to any difficulties which they encountered.

All panels referred to in this version are the same as those in the final programme and are in Appendix (iii). P1 indicates a frame in Section 1 of the first (preliminary) version of the programme, P2 in Section 2 and so on.

SECTION 1

ICE SHEETS AND GLACIERS

P1

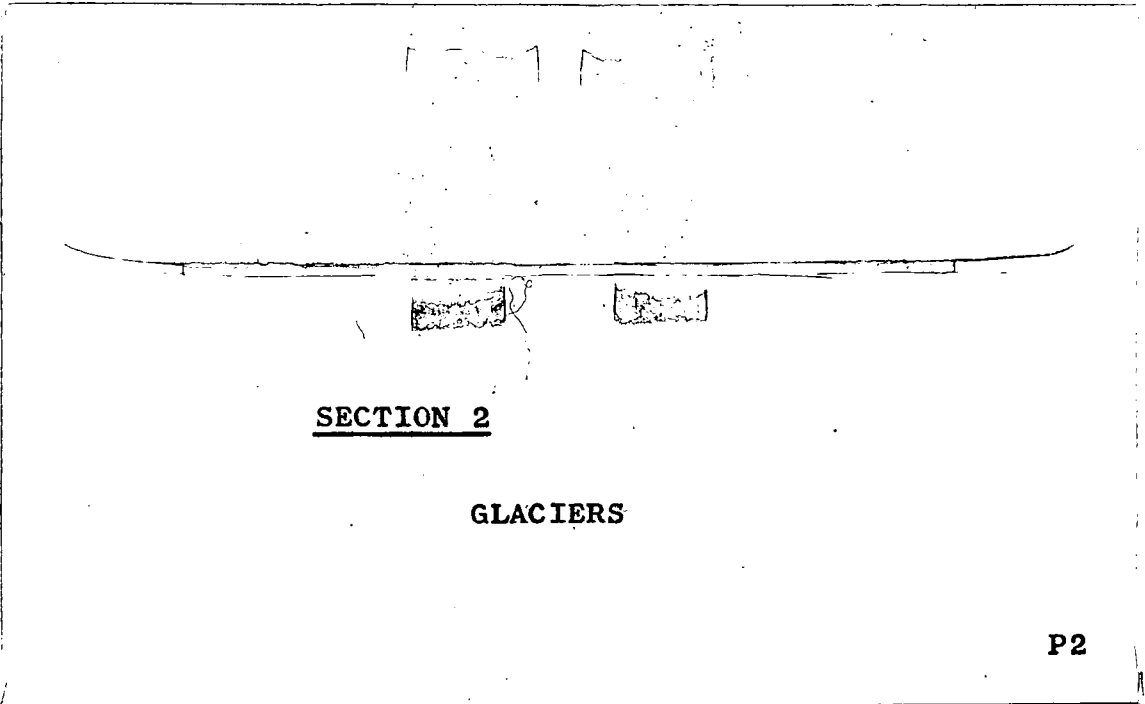

SECTION 2

GLACIERS

P2

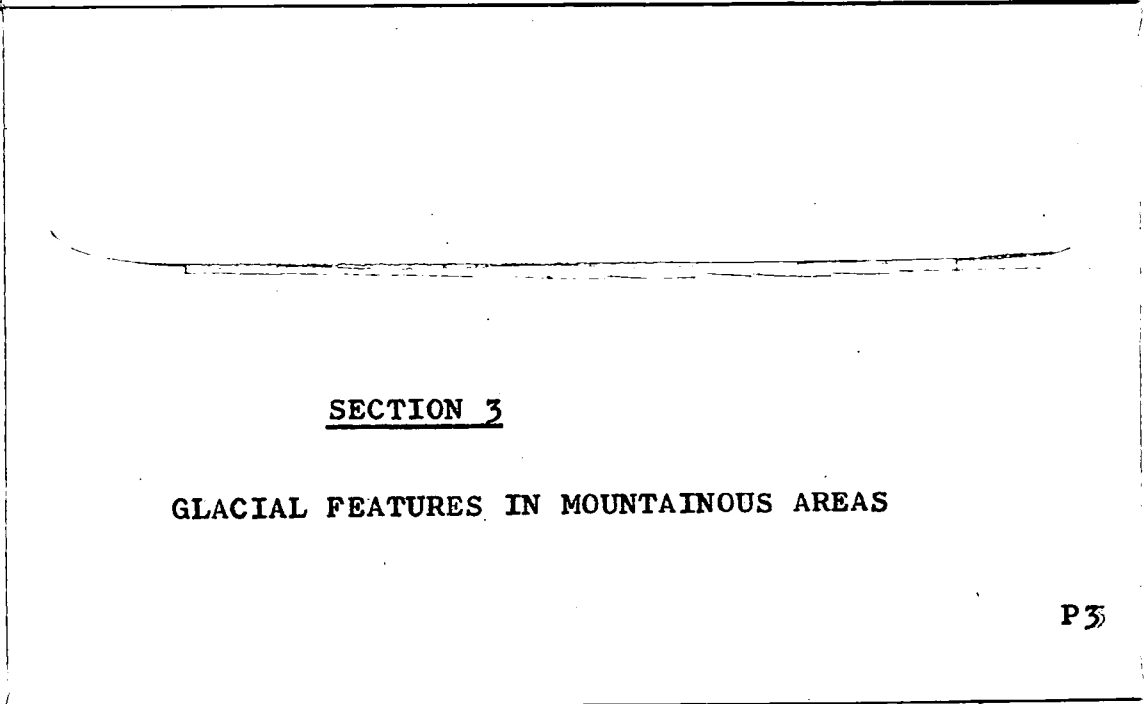

SECTION 3

GLACIAL FEATURES IN MOUNTAINOUS AREAS

P3

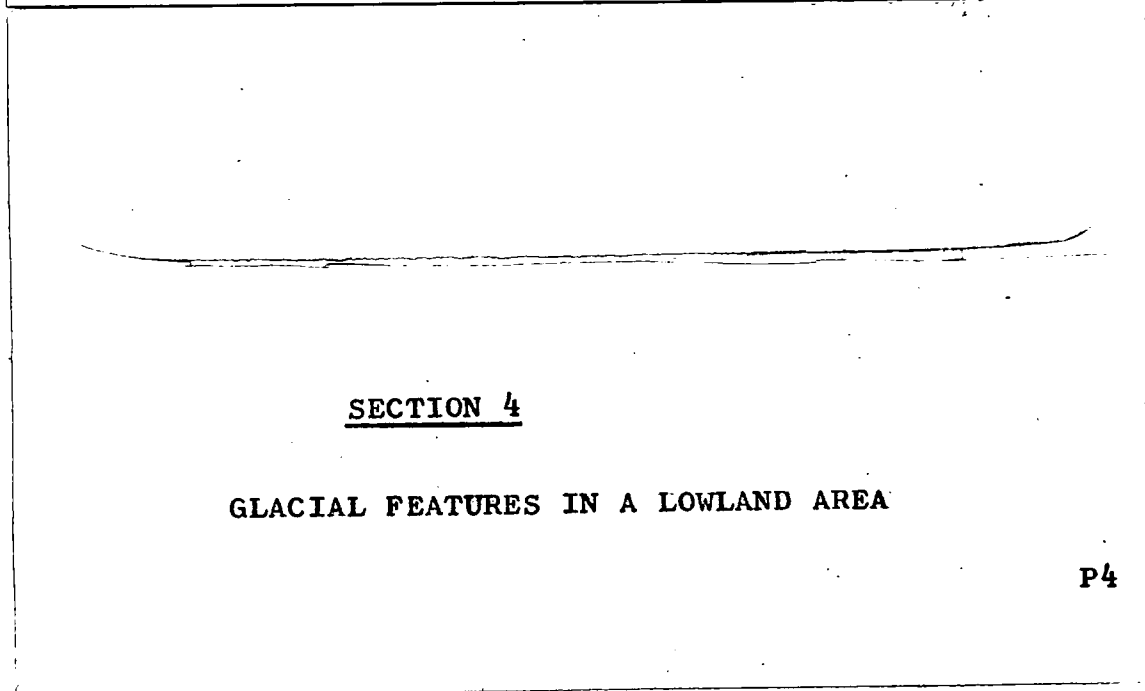

SECTION 4

GLACIAL FEATURES IN A LOWLAND AREA

P4

SECTION 5

GLACIAL FEATURES ON AN O.S.MAP

P5

TEST 1

- 1 The temperature is cold enough for snow to be present all the year 1) _____ 2) _____.
- 2 Describe an ice sheet. Give one example.
- 3 Mountain peaks visible in a large area covered by ice are called _____.
- 4 The line on a mountainside, above which snow is always present is the _____.
- 5 What is a river of ice called?
- 6 How does the snow change to ice?
- 7 Name one area in Europe where snow and ice are present all the year round.

TEST 2

- 1 Name one area in Europe which has snow fields and glaciers.
- 2 In which directions do all the glaciers move?
- 3 Within the glacier, the ice does not move at the same rate. Which moves the slowest? Why is this?

- 4 a) What is a crevasse? b) What is a sérac?

Name two causes of crevasses.

- 5 The loose material, which falls onto the glacier, from the mountainside is called _____. What causes the mountain rock to fall into pieces?
- 6 What do numbers 2 and 3 indicate in Panel 2.1?
- 7 Name a river which starts as a glacier.
- 8 Draw a diagram to represent the end of a glacier.
Label terminal moraine, snout, moraine-dammed lake.
- 9 Name a moraine-dammed lake.

TEST 3

- 1 The main work of the ice in a highland area is _____.
- 2 Name a British Highland which has been glaciated.
- 3 List 2 glacial features which are present high up on the mountain side. Give one example of each.

4

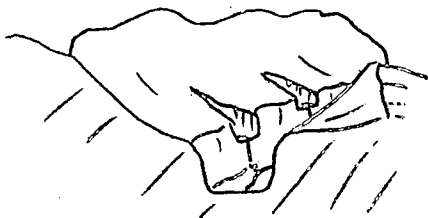

Copy this diagram and label 4 glacial features on it.

- 5 Draw a labelled diagram of a corrie. Describe its chief characteristics.
- 6 What is an arête?
- 7 How does a glaciated valley differ from a river valley?
- 8 What is a ribbon lake? Name one.

TEST 4

- 1 The work of the ice in a lowland area is mainly _____.
- 2 In the following chart (i) list the glacial features present in a lowland area (ii) what are they made of? (iii) give one example of each.

Name of feature	made of	example
1		
2		
3		
4		

TEST 5

You will require the O.S. map Panel 5.1 for this test. Use only the map area east of grid line 10 and south of grid line 16 for this question.

- 1 Find evidence on the map which suggests that this area of the Lake District has been glaciated by giving one named example of each of the following: arête, corrie, U-shaped valley, hanging valley and ribbon lake. State clearly which is which.

Appendix (vi)Learning Programme - Second Version

This programme consists of five sections (146 frames). The programme with its associated post-tests was studied by thirty pupils during five lesson periods. The frames are again presented on individual slips of paper with the confirmation on the reverse.

On this occasion a pre-test (included below) was given to the pupils prior to programme study. The pre-test and post-test are parallel tests.

All panels referred to are the same as those used in the final programme and are in Appendix (iii). S1 below indicates a frame in Section 1 of the second version of the learning programme.

SECTION 1

ICE SHEETS AND GLACIERS

S1

SECTION 2

GLACIERS

S2

SECTION 3

GLACIAL FEATURES IN MOUNTAINOUS AREAS

S3

SECTION 4

GLACIAL FEATURES ON AN O.S.MAP

S4

SECTION 5

GLACIAL FEATURES IN LOWLAND AREAS

S5

PRE-TEST

Attempt all sections of this paper. All answers to be written on the answer sheet provided.

Test 1

- 1 A large lowland area covered by snow is called an _____. Give one example.
- 2 What is an iceberg?
- 3 A nunatak is _____.
- 4 The snow accumulates on the mountains in a _____ or in a much smaller _____.
- 5 What is the snowline?
- 6 The snow may fall from the mountain side as an _____ or flow down a valley as a _____.
- 7 What is a glacier?

Test 2

- 1 A glacier moves slowly down the mountainside. Because of friction the ice at the _____ of the glacier moves more slowly.
- 2 The cracks which form in the ice are called _____, while the pinnacles of ice between the cracks are _____.

- 3 These cracks may form in the ice as it moves because of (i) _____ or (ii) _____.
- 4 What is moraine? Describe how it gets to the surface of the ice. The moraine carried at the edge of the ice is a _____ moraine.
- 5 Name a river which starts as a glacier.
- 6 Draw a labelled diagram which shows how a moraine-dammed lake is formed. Give one example.

Test 3

- 1 The main work of the ice in a highland area is _____.
- 2 _____ is a glaciated highland in Britain.
- 3a) What is an arête? b) Describe a corrie with the aid of a diagram. c) Where are arêtes and corries found in a highland area?
- 4 A glaciated valley is called a _____ valley. Describe it.
- 5 How are hanging valleys formed?
- 6 A ribbon lake is _____ in shape. It is found in _____. One example of such a lake is _____.

Test 4 Use the O.S. map for this section

- 1 The two red letters in grid square 1519 on the map are _____.
- 2 The direction of Lake Buttermere from Ennerdale Water is _____.
- 3 Find one example of each of the following glacial features from the map: arête, corrie, U-shaped valley, hanging valley, ribbon lake. State clearly which is which.

Test 5

- 1 The work of the ice in a lowland area is mainly _____.
- 2 Much of lowland Britain is covered by _____.
- 3 Eskers are common in _____. They consist of _____ and _____ and are formed by _____.
- 4 Drumlins are _____ hills made of _____. They can be found in Britain in _____.
- 5 Large boulders deposited by the ice many miles from their point of origin are called _____. _____ is an example.

POST-TESTTEST 1

- 1 Describe an ice sheet. Give one example.
- 2 Mountain peaks visible above an ice sheet are called _____.
- 3 In the mountains snow collects on the _____ or in small hollows called _____.
- 4 The line on the mountainside, above which snow is always present is the _____.
- 5 How does the snow change to ice?
- 6 What is a river of ice called?
- 7 Name one mountain range in Europe where snow and ice are present all the year round.

TEST 2

- 1 Within the glacier the ice does not move at the same rate. Which moves the slowest? Why is this?
- 2a) What is a crevasse? b) Crevasses may be caused by
i) _____ ii) _____. c) What is a sérac?

- 3 The loose material, which falls onto the glacier, from the mountainside is called _____. What causes the mountain rock to fall into pieces?
- 4 What do numbers 1) _____ and 2) _____ show in Panel 1.2?
- 5 Name a river which starts as a glacier.
- 6 Draw a diagram to represent the end of a glacier. Label terminal moraine, snout, moraine-dammed lake.
- 7 Name a moraine-dammed lake.

TEST 3

- 1 The main work of the ice in a highland area is _____.
- 2 Name a British highland area which has been glaciated.
- 3 List 2 glacial features which are present high up on the mountainside. Give an example.

4

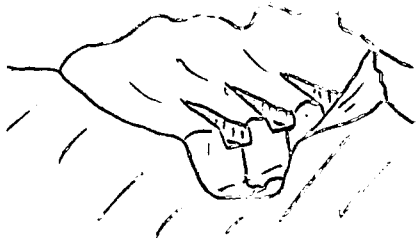

Copy this diagram and label 3 glacial features on it.

- 5a) Describe a corrie b) draw a labelled diagram to illustrate c) Explain how the corrie is formed.
- 6 What is an arête?
- 7 How does a glaciated valley differ from a river valley?
- 8 What is a ribbon lake? Name one.

TEST 4

You will require the O.S. map Panel 4.1 for this test. Use only the map area east of grid line 10 and south of grid line 16 for this test.

- 1 Find evidence on the map which suggests that this area of the Lake District has been glaciated by giving one example of each of the following features: arête, corrie, U-shaped valley, hanging valley and ribbon lake. State clearly which is which.

TEST 5

- 1 What is the Ice Age?
- 2 Name the 2 continents most affected by the Ice Age.
- 3 The work of the ice in a lowland area is mainly _____.
- 4 In the following chart i) list the glacial features present in a lowland area ii) what are they made of? iii) where can you find one example of each?

Name of feature	made of	example
1		
2		
3		
4		

Appendix (vii)Field Test 1 Post-Test Analysis and Frame ResponseError RatesSECTION 1

<u>Question</u>	<u>Teaching Point</u>	<u>% success</u>	
1	Ice sheet	76	
	example	80	
2	nunatak	70	
3	snowfield	53	
	corrie	76	
4	snowline	93	
5	snow to ice	pressure	70
		temperature	90
6	glacier	90	
7	Alps	93	

Percentage of Errors occurring at each Frame (n 30)

Frame	%	Frame	%	Frame	%	Frame	%
1	3	10	20	18	43	28	13
2	13	11	30	19	A 13 B 20	29	(i) 40
	13	12	20				(ii) 41 (2)
3	3	13	30	20	37	30	(ii) 41 (2)
4	a 33	14	a 0	21	((i) 50 ((ii) 27		31
	b 40		b 0			32	4 (5)
5	10	c 3	d 57	22	27	33	24 (7)
6	17			23	27	34	13 (7)
7	0	15	30	24	7	22	(7) 22 (7)
8	37	16	20	25	13		
9	3	17	3	26	7		
	3			0	27	23	

() pupils failing to reach this frame.

Field Test 1

SECTION 4

<u>Question</u>	<u>Teaching Point</u>	<u>% success</u>
1	Ice Age	96
2	continents	96
3	deposit	92
	(i) boulder clay	63
	(ii) made of	63
	(iii) example	50
	(i) drumlins	83
	(ii)	63
	(iii)	83
	(i) eskers	50
4	(ii)	33
	(iii)	33
	(i) erratics	96
	(ii)	50
	(iii)	83

Percentage of Errors occurring at each Frame (n 24)

Frame	%	Frame	%	Frame	%	Frame	%
1	{ 4	9	8		{ 0	24	{ 13
	4	10	13	18	0		8
2	8	11	0		0	25	13
3	8	12	8	19	{ 0		{ 25
4	8	13	8		0	26	{ 8
5	21	14	4	20	4		
6	13	15	17	21	4		
7	33	16	29	22	4		
8	29	17	{ 4	23	4		
			{ 17				

Field Test 1

SECTION 5

<u>Teaching Point</u>	<u>% success</u>
arête	52
corrie	30
U-shaped valley	48
hanging valley	26
ribbon lake	70

Percentage of Errors occurring at each Frame (n 23)

Frame	%	Frame	%	Frame	%	Frame	%
1	{ 0		{ 13	14	0		{ 54
	{ 0	8	{ 8	15	{ 0	19	{ 59
2	35		{ 57		{ 13	20	32
3	8	9	{ 26	16	{ 4	21	{ 19 (2)
4	{ 0		{ 30		{ 13	22	{ 38 (2)
	{ 4	10	0	17	{ 4	23	20 (3)
5	39	11	{ 8		{ 0	24	6 (6)
6	{ 0		{ 22	18	{ 0		{ 23 (6)
	{ 17	12	26		{ 4	25	{ 23 (6)
7	4	13	{ 35				29 (6)
			{ 69				

() pupils failing to reach this frame

Appendix (viii)Learning Programme - Third Version

The programme now comprises 154 frames arranged in five sections. It is duplicated in booklet format and includes an explanatory introduction. A vertical progression is used with confirmation of student frame response at the top of the next frame. Fifty one girls worked through this programme during five lesson periods.

The tests on pages 1-3 of the booklet were used as a pre-test and retention test. Tests appearing at the end of each section were used as the post-test. These are parallel tests.

All panels referred to are the same as those used in the final programme and are in Appendix (iii).

A Learning Programme in Geography

GLACIATION

by

E. SHEPHERD

DEPARTMENT OF EDUCATION-DURHAM UNIVERSITY

ABOUT THIS BOOKLET

This is a learning programme, which will teach you about glaciation. The programme is divided into five main sections. Each section, which is followed by a short test, will take you one lesson to complete.

The sections are sub-divided into small parts called frames. You are asked to read the first frame and answer the question set in it. Write your answer on the answer sheet provided before moving on to the next frame. The next frame gives you the correct answer and a new piece of information.

From time to time the frames refer you to maps, photographs etc., which are separate from this booklet. They are called Panels.

First answer the following test, on the paper provided. If you know most of the answers it will be unnecessary for you to study this programme.

GLACIATION PRE-TEST

Attempt all five parts of this test.

All answers are to be written on the answer sheet provided.

TEST 1

1 (i) A large lowland area covered by an ice and snow is called ^{an} _____ . (ii) Give one example.

2 A nunatak is _____ .

3 What is an iceberg?

4 In the mountains snow collects in large _____ or in much smaller depressions (hollows) called _____ .

5 The line on the mountainside, above which snow is always present, is the _____ .

6 The snow may fall quickly from the mountain as an _____ or flow very slowly down a valley as a _____ .

7 Name a mountain range in Europe, which has a snowfield.

continued over the page

Test 2

- 1 The ice within a moving glacier does not move at the same speed. a) Which moves the slowest? b) Explain this.
 - 2 The cracks which form in the ice are called _____, and the pinnacles of ice between these cracks are _____.
 - 3 These cracks will form in the ice if the valley suddenly either _____ or _____.
 - 4 i) What causes pieces of rock to break off the mountain peaks? ii) This loose material, which falls onto the glacier ~~is~~ and is carried by it, is called _____. iii) If the loose material is carried along the sides of the glacier it is a _____.
 - 5 The river _____ starts as a glacier.
 - 6 Draw a clear diagram to represent the end of a glacier. Label terminal moraine, snout, moraine-dammed lake.
 - 7 Name a moraine-dammed lake.
-

TEST 3

- 1 The main work of the ice in a highland area is _____.
 - 2 Name a British highland which has been glaciated.
 - 3 a) i) What is an arête? ii) Give one example.
b) i) Describe a corrie, with the aid of a diagram.
ii) Give one example. c) Where, in a glaciated highland, are the arêtes and corries?
 - 4 a) What is the main valley, in a glaciated highland area, called? b) Describe it with the aid of a diagram c) List any features in it, which are a result of glaciation d) How does it differ from a river valley?
 - 5 a) Describe a ribbon lake b) Name one example.
-

TEST 4

Use the O.S. map for this section

- 1 The two red letters in grid square 1519 on the map are _____
 - 2 Lake Buttermere is due _____ from Ennerdale Water.
 - 3 Find one example of each of the following glacial features from the map: arête, corrie, U-shaped valley, ribbon lake. State clearly which is which.
-

TEST 5

- 1 The work of the ice in a lowland area is mainly _____.
- 2 As a result of the Ice Age, much of lowland Britain is covered with _____.
- 3 Eskers are common in _____. They consist of _____ and _____ and were formed by _____.
- 4 Drumlins are _____ hills made of _____. They can be found in Britain in _____.
- 5 Large boulders, deposited by the ice, many miles from their point of origin, are called _____. Give one example.

HOW TO USE THE PROGRAMMED SECTIONS OF THIS BOOK

Frame 1 First cover all the frames on this page, except this one. Use the card provided in the book. The frames should be covered with a _____. When you can complete this sentence move on to the next frame.

2

card

Do not write on this page but on the answer sheet provided. All answers must be written on the _____.

3

answer sheet

You will learn more from this programme if you always answer the question before moving on to the next frame. Always answer the question f_____.

4

first

The next frame gives the correct answer. Check your answer and mark it with a ✓ or X.

<u>CONTENTS</u>		Page
About this booklet		1
Glaciation Pre-test		1
How to use the programmed sections of this		3
Contents	book	4
Glaciation programme		5
Section 1	Ice Sheets and Glaciers	5
	Test 1	10
Section 2	Glaciers	11
	Test 2	10
Section 3	Glacial features in a mountainous area	19
	Test 3	25
Section 4	Glacial features on an O.S. map	26
	Test 4	30
Section 5	Glacial features in a lowland area	31
	Test 5	36

PANELS

- 1.1 'Titanic' Disaster
- 1.2 Mer de Glace in the Alps
- 3.1 Maximum extent of ice sheet in Britain
- 3.2 Blea Tarn in the Lake District
- 3.3 Field sketch of Blea Tarn area.
- 4.1 1" O.S. map of Lake District. Map extract No. 226/82
- 5.1 Maximum extent of Ice Sheets in Northern Hemisphere
- 5.2 Present extent of Ice Sheets in Northern Hemisphere
- 5.3 Strangford Loch; Co: Down, Northern Ireland

8

a nunatak

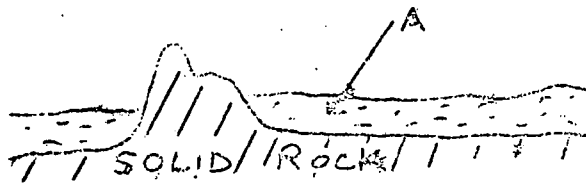

In this diagram A is an _____.
 _____ . A nunatak is also
 shown. Describe it in your own
 words.

9

A ice sheet; an area of rock projecting above
 the ice

From the centre of Greenland the ice moves slowly
 outwards towards the sea. The action of the waves causes
 large blocks of ice to _____ .

10

~~break off~~ break off

These large blocks of ice, which float away, are called
 _____. They are able to float because ice is
 heavier/lighter (choose one of these) than water.

11

icebergs; lighter

They are lighter because water _____ when it freezes.
 Not sure? Well, if the water freezes in your pipes at
 home, in winter, it will also _____ causing the pipes
 to burst.

12

expands

In fact, when water freezes it increases in volume by
 about 10%. If this is so, how much of the iceberg will be
 visible above sea level?

13

1/10th or 10%

Many liners and cargo ships use the busy shipping lanes
 between Europe and North America. Near North America there
 is a danger to the ships from icebergs. Where are these
 icebergs floating from? (Use your atlas page 2).

14

Greenland

Now turn to Panel 1.1 and read an account of the fate of a famous ship. a) What was the ship called? b) When did the event take place? c) Where did this occur?

15

a) Titanic b) 1912 c) south of Newfoundland

The ice leaves an ice sheet as an _____ .

16

iceberg

Because the temperature decreases as you ascend/descend (choose one of these) a mountain, permanent snow will be found at the _____ of many mountains.

17

ascend; top

If the mountain is _____ enough permanent snow will be present even near the equator.

18

high

The area where the snow accumulates at the top of the mountain is called the snowfield. In the photograph (Panel 1.2), which was taken in the Alps, the snow is collecting in the large area marked S. S is a _____ .

19

snowfield

The lower edge of the snowfield is called the snowline. What are A and B?

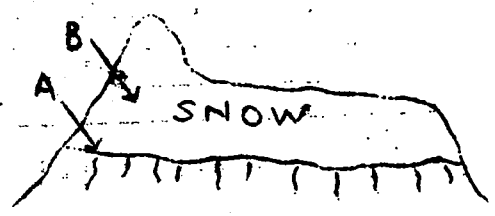

20

A snowline; B snowfield.

On the mountainside, there is always snow above the β _____ .

21

snowline

The table below shows the actual height of the snowline on three mountains:

Alps	46°N	9,000ft
Himalayas	30°N	16,000ft
Mt. Kilimanjaro	3°S	18,000ft

- (i) Is the snowline higher or lower on the mountainside as the equator is approached? (ii) All these mountain ranges have a permanent snow field. Which one is in Europe?

22

(i) higher (ii) ~~Europe~~ Alps

Each new snowfall adds to the snow in the mountains. Some of the snow will fall or avalanche down the st
sl. Much more will slowly change to ice.

23

steep slopes

A large snowfall is called an _____.

24

avalanche

The snow is deepest in hollows near the mountain peaks. These hollows are called corries. In Panel 1.2 the letter C indicates a number of _____.

25

corries

The hollows in which the snow collects are called _____ . They can be found near the _____ .

26

corries; mountain peaks

The snow, at first, has many air pockets between the snowflakes. Soon, however, the air is forced out and the snow changes to _____ .

27

ice

In the mountains the weight of snow causes the snowflakes to change to ice. The ice forms because of the _____ of the snow above.

28

pressure

Also, during a clear, sunny day the temperature rises and the snow will _____. At night it will freeze again. Continued thawing and _____ causes the snowflakes to change to ice.

29

~~thaw~~ thaw(melt);freezing

In the snowfield the snow will change to ice for two different reasons:They are i) _____

ii) _____

30

i) pressure ii)thaw-freeze action

The ice flows slowly down the slopes,like a _____.

31

river

A river of ice is called a glacier.In the photograph (Panel 1.2) G shows a _____.

32

glacier

This glacier is flowing down the valley from the _____.

33

snowfield

From the snowfield the _____ flows down towards the lowland.

34

glacier

The snow, which falls above the snowline, leaves the mountain suddenly as an _____, or much more slowly as a _____.

-avalanche; glacier

You have now completed Section 1

Answer the questions in Test 1 on page 10.

TEST 1 Answers to be written on the back of your
Section 1 answer sheet

- 1 (i) Describe an ice sheet. (ii) Give one example.
- 2 Mountain peaks visible above an ice sheet are called _____.
- 3 In the mountains, the snow accumulates on the _____ or in small hollows called _____.
- 4 What is the snow line?
- 5 How does the snow change to ice?
- 6 What is a river of ice called?
- 7 Name one mountain range in Europe where snow and ice is present all the year round.

TEST 2 Answers to be written on the back of your
Section 2 answer sheet.

- 1 Within the glacier, the ice does not move at the same rate. a) Which moves the slowest? b) Why is this?
- 2 a) What is a crevasse? b) Crevasse may form when the valley _____ or when there is a _____.
- 3 c) What is a sérac?
- 3 i) What is moraine? ii) Where does the moraine come from? iii) In Panel 1.2 what does 1 indicate?
- 4 Name a river which starts as a glacier.
- 5 Draw a labelled diagram to show how a moraine-dammed lake is formed.
- 6 Give one example of a moraine-dammed lake.

SECTION 2 Glaciers

34 frames

1 Snow accumulates to a great depth in a _____.

2
_____ snowfield(corrie)

Snow changes to ice because of the _____ of the snow above.

3
_____ pressure

A river of ice flows down the mountainside. It is called a _____.

4
_____ glacier

The movement of the glacier can be measured by placing a row of stakes across the ice, as in diagram 1. The second diagram shows the position some days later.

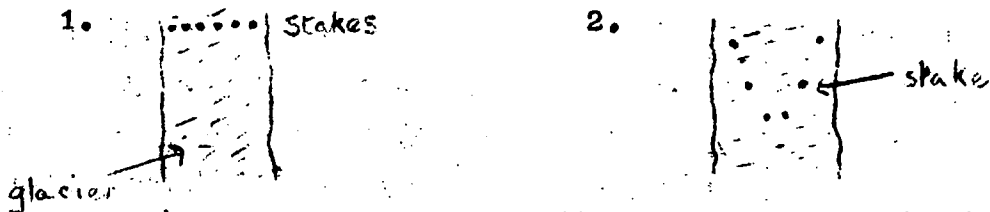

- a) Draw an arrow to indicate the movement of the ice.
b) Which part of the ice is moving slowest?

5
a) ↓ b) sides

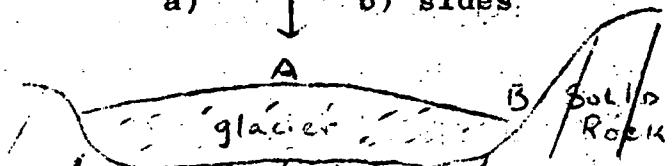

This is a section across the glacier. Will the ice at B be moving quicker or slower than at A?

6

slower

Why does the ice at the sides of the glacier move more slowly? Not sure? Then move your finger along the top of the desk, first just above it, then with your finger pressing on the desk. Which movement is the slowest? Why is this?

7

friction; the second; friction (desk holding back movement)

The ice is held back at the sides of the glacier because of the _____ between the ice and the solid rock of the mountainside.

8

friction

The glacier moves down the mountainside until the temperature is warm enough to melt the ice. When this happens the meltwater will flow down the slopes as a _____.

9

river

The end of the glacier is called the snout. i) Draw an

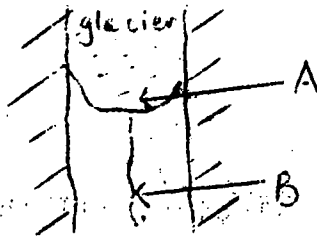

arrow to indicate the movement of this glacier. ii) A is the end of the glacier or the _____. iii) B is the result of a warmer temperature; it is a _____.

10

i) ↓ ; ii) snout; iii) river

The river Rhine and river Rhône flow from the snowfields in the Alps. Name a river which starts as a glacier.

11

Rhine or Rhône

Like a river, the glacier moves down a valley. If the valley becomes wider at some point, the glacier moving down it may crack in a number of places. Large cracks or gashes in the ice are called crevasses. A in this diagram is a

~~During the day the temperature is warm and the rock is soft. At night it is very cold and the rock is hard.~~

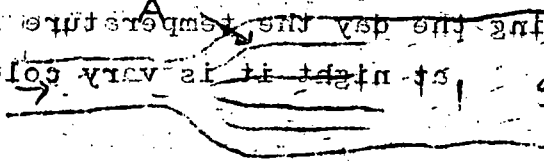

12

crevasse

These crevasses formed when the valley _____

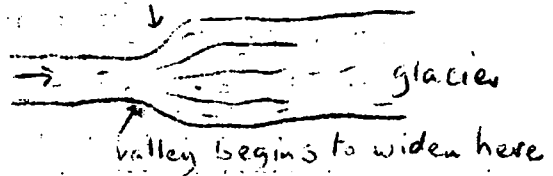

13

widened

Crevasses will also occur if the profile of the valley (the slope of the valley floor from the snowfield to the snout) is irregular at any point. Copy this diagram

and mark with an X the point where there is a sharp change in the slope of the valley floor.

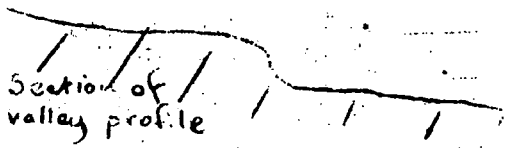

14

~~During the day the temperature is warm and the rock is soft. At night it is very cold and the rock is hard.~~

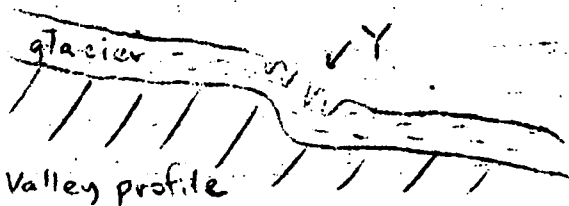

The valley profile now shows that the ice has cracked at point Y. 1. What is the feature at Y? 2. At which point in the valley floor have these cracks occurred?

14

15

1 crevasse; ²sharp change of slope

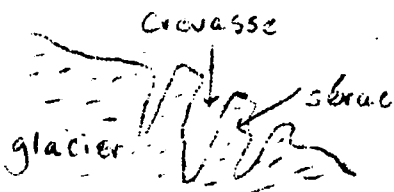

This is an enlargement of point Y in the last frame. The large ~~erack~~ cracks in the ice are _____.

The pinnacles of ice remaining between them are _____.

16

crevasses; séracs

Crevasses will form i) if the valley _____ or ii) if there is a _____ in the valley floor.

17

widens; sharp change of slope

In Panel 1.2 point X indicates a number of _____, which have been caused by _____.

18

crevasses; sharp change of slope in valley

If the glacier moves over a very steep fall in the valley floor, the ice breaks up into a chaotic pattern of cracks and pinnacles. This is called an icefall,

In Panel 1.2 Y indicates _____. It is the result of _____.

19

an icefall; very steep fall in valley floor.

Many pieces of rock break off the mountains ~~the~~ peaks and fall onto the ice. The pieces become loose because of changes in temperature. The pieces of rock, which fall onto the ice, come from the _____. This is a result of changes in _____.

20 mountain peaks; temperature

During the day the temperature is warm and the rock
e _____, at night it is very cold and the rock _____.

21

expand; contract

Alternate expansion and contraction, day after day,
causes the rock to _____.

22

break (crack, splinter)

The loose pieces of rock, which fall onto the ice, are
called moraine. In Panel 1.2 numbers 1 and 2 are both
_____.

23

moraine

If the moraine is carried on the sides of the glacier,
it is a lateral moraine. On the photograph 1 is a _____.

24

lateral moraine

If two moraines meet and join, two of the lateral moraines
are carried down the centre of the glacier as a medial
moraine. In this diagram A and C

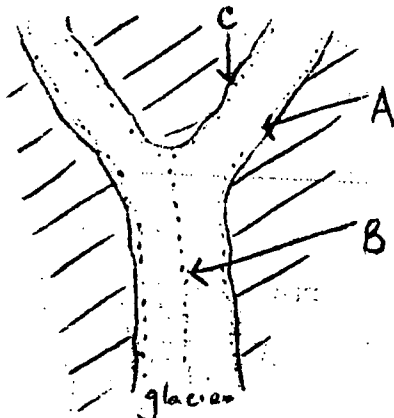

are at the sides of the glacier;
they are _____ . B is
in the centre of the glacier and
is a _____ .

25 lateral moraines; medial moraine

In Panel 1.2 number 2 is a _____ .

26 medial moraine

The glacier carries and pushes the moraine, down the valley, to it's snout. When the ice melts, the moraine is _____ or deposited. Here it forms a terminal moraine.

27 dropped(left behind)

This diagram shows a _____ moraine. The moraine is deposited a _____ the valley.

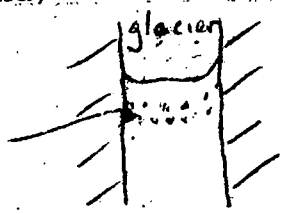

28 terminal; across

The end of the glacier is not always in the same position across the valley. If the temperature becomes colder, over a long period of time, the end of the glacier will move _____ the valley.

29 down.

A _____ moraine will form, across the valley, in this new position.

30 terminal

If now the temperature becomes warmer, over a long period of time, the ice will melt and the snout will move _____ the valley, leaving the terminal moraine behind. What are A and B?

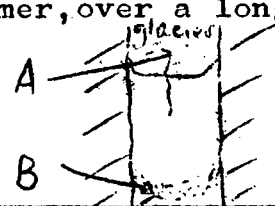

31

up; A snout, B terminal moraine

Icy cold water will flow from the end of the glacier. In this diagram A is a _____.

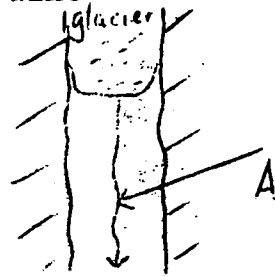

32

river

The old terminal moraine lower down the valley may dam the river, causing a _____ to pond up behind it.

33

lake

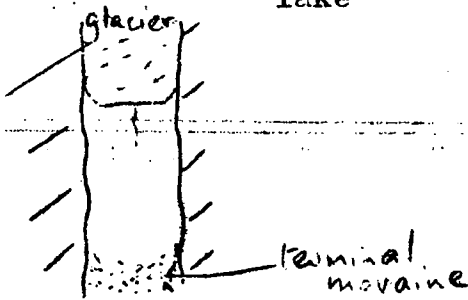

Copy this diagram. Fill in a lake formed in this way. Label the lake a moraine-dammed lake.

34

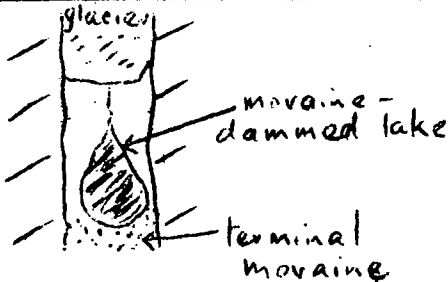

The biggest lake in the Lake District was formed in this way. What is it called? (Use your atlas page 24).

L. Windermere

You have now finished Section 2

Now answer Test 2 on page 18.

Test 2 Answers to be written on the back of your
Section 2 answer sheet.

- 1 Within the glacier, the ice does not move at the same rate. a) Which moves the slowest? b) Why is this?
 - 2 a) What is a crevasse? b) Crevasses may form when the valley _____ or when there is a _____
c) What is a sérac?
 - 3 i) What is moraine? ii) Where does the moraine come from?
iii) In Panel 1.2 what does 1 indicate?
 - 4 Name a river which starts as a glacier.
 - 5 Draw a labelled diagram to show how a moraine-dammed lake is formed.
 - 6 Give one example of a moraine-dammed lake.
-
-

SECTION 3 Glacial Features in a Mountainous Area

32 frames

1 Panel 3.1 shows that Britain was covered by ice north of a line connecting the towns of _____ and _____.

2
Bristol and London

This means that most of _____ has been affected by the ice.

3
Britain

Using Panel 3.1, name a highland area in Britain, where we can study the effects of the ice.

4
any one from Welsh Upland, Lake District, Grampians, N.W. Highlands

In the mountains the main work of the ice was to wear away or erode the surface. Mountains are _____ by the ice.

5
eroded

In these areas snow accumulated in hollows, called _____ high up on the mountain sides.

6
corries

The snow changed to _____ and slowly _____ the hollows, so that they became bigger.

7

ice;eroded

Changes in temperature (freeze-thaw process) caused pieces of rock to fall from the backwall of the corrie.

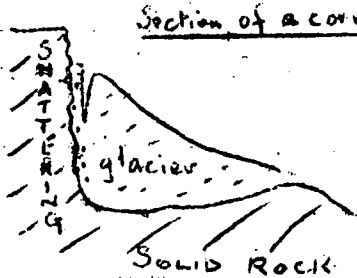

Section of a corrie

This diagram shows that the backwall became (i) smooth/rugged; (ii) and the slope very steep/steep/moderate/gentle (choose one of these).

8

rugged;very steep

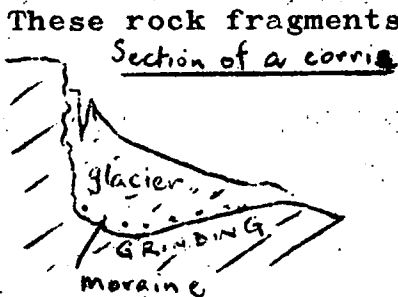

Section of a corrie

These rock fragments were carried in the ice. They helped to erode the bottom of the corrie. Here (i) there is a smooth/rugged surface (choose one), (ii) the slope is _____.

9

i) smooth (ii) gentle

The feature shown by this diagram is a _____. The slope of the backwall is _____ and of the base is _____.

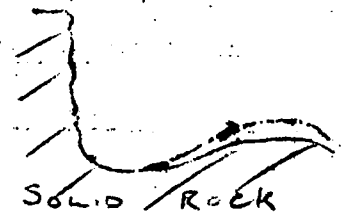

10

corrie;very steep;gentle

The corrie is eroded by the _____. It forms _____ on the mountain side.

11

ice;high up

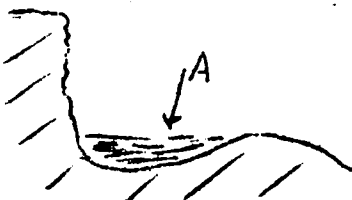

When the ice melts, a small lake or tarn may remain in the bottom of the corrie. In the diagram A is a _____.

12

tarn

A corrie is circular and arm-chair shaped, because it has _____ walls and a _____ base.

13

very steep; flat

Panel 3.2 is a photograph taken in the Lake District. 1 on the photograph is a _____. Panel 3.3 is a field sketch of the area. Use it to find the actual name of 1.

14

corrie; Blea Tarn

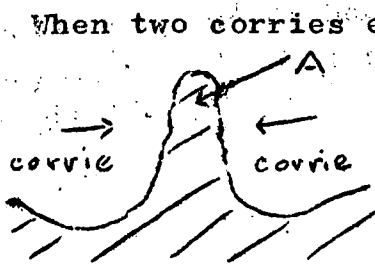

When two corries erode backwards into the mountain a razor-edged ridge results, called an arête. A is an _____. It is described as razor-edged because the slopes of the ridge are _____.

15

arête; very steep

Arêtes, like corries, are found _____ on the mountain side,

16

high up

On the photograph 2 is an _____. Panel 3.3 shows that its name is _____.

17

arête; Riggindale Crag

The glacier, in the main valley, collects material in its sides and base, which converts it into a giant rasp. It moves slowly, rubbing against the sides of the valley. The main work of the glacier is to wear away of _____ the surface.

18 erode

A normal river valley is V-shaped in cross-section. One through which a glacier passed is U-shaped. Diagrams 1 and 2 are cross sections of two valleys. Which one has been glaciated?

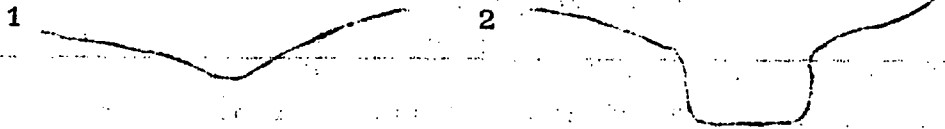

19

2

When a glacier passes down a valley, it changes the shape from V-shaped to _____.

20

U-shaped

The sides of a U-shaped valley are very _____ and the valley bottom is w_____ and f_____.

21

steep; wide and flat

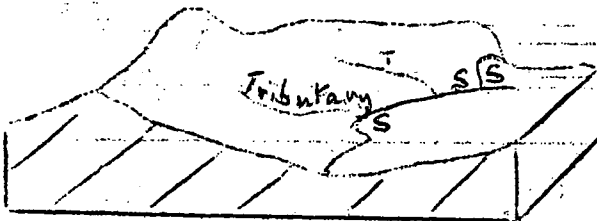

This is a river valley. T on the diagram is a _____ valley. The higher areas extending into the valley are called spurs.

What does S indicate?

before glaciation

22

tributary; spur



during glaciation

During the Ice Age, a glacier moved along this valley making it _____ er and _____. It is called a _____ valley.

23

wider and deeper; U-shaped

The glacier is fairly solid-it does not flow round the spurs. They are removed or _____ (truncated).

24

cut off

In the photograph, the valley marked 3 is _____.
Panel 3.3 shows that its name is _____.

25

U-shaped; Riggindale

The glaciers in the tributary valleys are bigger/
as big/ smaller than in the main valley.

26

smaller

Because they are smaller, the valleys which they cut will
be bigger/smaller (choose one) than the main-main valley.

27

smaller

When the ice melts, the small
tributary valleys 'hang' above
the main valley. They are
called 'hanging valleys'.

What are A and B?

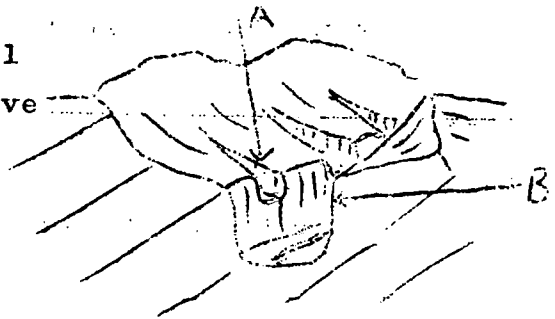

28

hanging valley; U-shaped (main) valley

The tributary streams will frequently fall over the
steep edge of the main valley, as a _____.

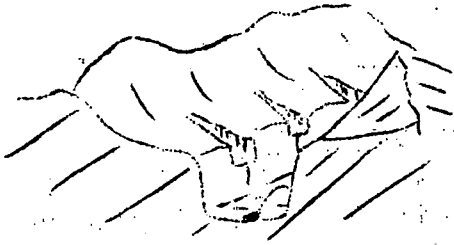

Copy this diagram and label a U-shaped valley, hanging valley, waterfall, truncated (cut off) spur.

In many of the U-shaped valleys large areas of water were left behind, when the ice melted, forming _____.

The lakes are long and thin because they formed at the bottom of the _____ valleys. They are called ribbon or finger lakes.

The ribbon lake in Panel 3.3 is called _____.

You have now finished Section 3

Answer the questions in Test 3 on page 25

Answers to be written on the back of your

TEST 3

Section 3 answer sheet

- 1 In a highland area the main work of the ice is to _____ the surface.
- 2 _____ is a glaciated highland in Britain.
- 3 a)(i) Describe an arête (ii) give one example.
b)(i) Describe, with the aid of a diagram, a corrie
(ii) give an example.
c) Where in a glaciated highland area can a) and b) be found?
- 4 Copy this diagram carefully and, using arrows, label 4 glacial features on it.
- 5 Describe a U-shaped valley. How was it formed?
- 6 a) What is a ribbon lake? b) Name one example.
c) Where, in a glaciated highland, is it found.

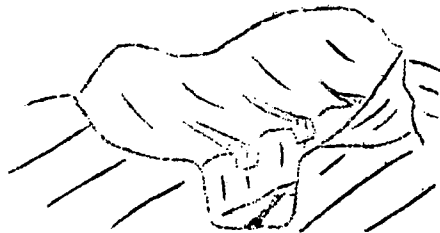

SECTION 4 Glacial Features on an O.S. map

25 frames

Use the Ordnance Survey map (Panel 4.1) for this section.

- 1 The brown lines in grid square 1724 are called _____ lines. They are used to show the _____ of the land.

2 _____
contour; height

Contours are drawn close together to show a steep slope and far apart when the slope is gentle. In square 0825 the slope is _____; in square 1019 the slope is _____.

3 _____
gentle; steep

In square 1622 there is another symbol which is also used to show height. Describe the symbol.

4 _____
short black lines (your own words)

These short black lines are called hachures. They are used to show very steep/steep/gentle slopes. (Choose one) .

5 _____
very steep

When the slope is so steep that it is almost vertical, the symbol used to represent it is called a _____.

6 _____
hachure

This map represents a glaciated highland area. List the 7 relief features, resulting from glaciation, that we would expect to find in such an area.

27

7

arête, corrie, U-shaped valley, hanging valley, waterfall, ribbon lake, truncated spur. (Enter the number correct on your answer sheet).

First we will look for an arête on the map. Will we find it on the mountain peaks or in the valleys?

8

mountain peaks

What is special about the slopes of an arête? On the map, the contours showing this slope will be _____

If the slope is extremely steep _____ will be used.

9

very steep; close together; hachures

Using the map area east of grid line 15 and south of grid line 17, find 2 named examples of an arête. Remember we are looking for a feature which is i) high up on the mountain side ii) has slopes which are so steep that many of them will be shown by hachures.

10

Any 2 from: Ling Comb, The Saddle, Chapel Crag, High Stile, High Crag.

What is the name given to the arm-chair shaped hollows, high up on the mountain sides?

11

corrie

How would you describe the corrie in terms of sides and Base?

12

steep (rounded) sides, flat base

Now draw a contour map of a corrie in this way. First draw a small tarn with a stream flowing out from it. Around this draw 4 contour lines in a pattern which shows the rounded arm-chair shape. Remember that the sides of the corrie are very steep and the base flat. Label the lowest contour 1, 1,000ft.

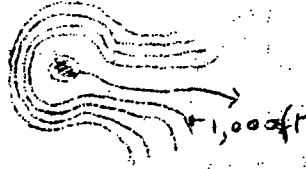

Now can you find a named example of a) a corrie with a tarn b) a corrie in the same map area. Remember we are looking for rounded, steep sided contour shapes, with the lowest land in the centre.

14

a) Bleaberry b) Ling Comb or Burtness Combe

The main valleys in a glaciated highland area are _____.

15

U-shaped

A ribbon lake is _____ and _____ in shape. Where in a glaciated highland area will it be found?

16

long and narrow; in a U-shaped valley

Find 2 examples of ribbon lakes anywhere on this map.

17

any 2 from: Buttermere, Crummock Water,
Ennerdale Water, Loweswater.

The slope of the sides of the U-shaped valley is _____
and the bottom of the valley is _____ and _____.

18

very steep; wide and flat

The sides will be shown by contour lines which are close together/wide apart (choose one of these); the base of the valley by contours that are close together/wide apart (choose one of these).

19

close together; wide apart

On the O.S. map find 2 examples of U-shaped valleys.

20

Crummock Water (Buttermere) valley,
R. Liza (Ennerdale) valley.

How many tributary streams flow into the Buttermere-Crummock Water valley from the west?

21

7 or 8

We wish to find if any or all of these tributary valleys are hanging valleys. This is a contour map of

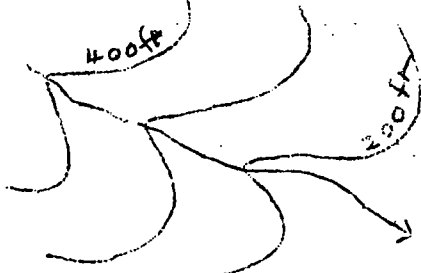

a river valley. The contours make a V-shape, with the apex (point) of the V pointing towards the Highland/lowland (look at the contour labels before making a choice). Where is the

river in relation to the V shape? The contours are evenly spaced because the slope of the valley is even.

22

highland; along the apex

A hanging valley does not have a graded (even) slope for its full length. At the point where it enters the main valley the slope is steeper/gentler (choose one) than near the source (beginning) of the stream.

23

steeper

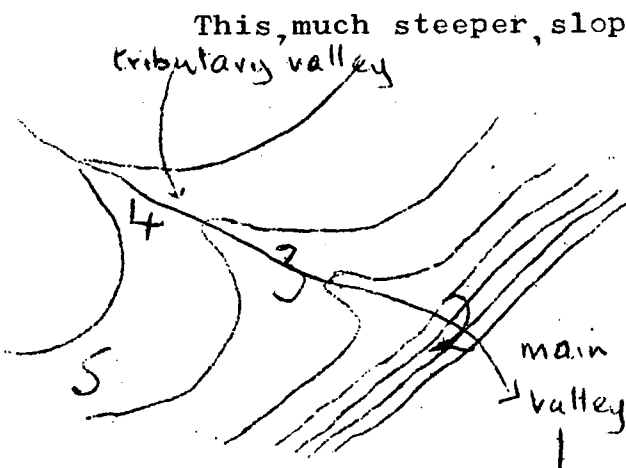

This, much steeper, slope is shown on a contour map by the contours cutting straight across the river, at the point where the valley is hanging. This contour map shows a hanging valley. At which point does this tributary valley 'hang' over the main valley?

Now look at the 8 small streams entering the Buttermere-Crummock Water valley from the west. If the contours cross the stream in a straight line, rather than making a V-shape, the valley is a 'hanging' valley. Give 2 named examples of hanging valleys.

25

2 from Scale Beck, Far Ruddy Beck, Sour Milk Gill .

Look closely at the map and find a waterfall along one of the streams entering the lakes from the west.

Scale Force or along Sour Milk Gill

This section is now complete.

Now answer Test 4 ~~on~~-page-34 set out below.

TEST 4 You will require the O.S. map (Panel 4.1) for this test.

Use only the map area east of grid line 10 and south of grid line 16.

- 1 Find evidence, on the map, which suggests that this area of the Lake District has been glaciated, by giving one named example of each of the following features: arête, corrie, U-shaped valley, hanging valley and ribbon lake. State clearly which is which.

SECTION 5 Glacial Features in a Lowland Area

29 frames

1 The map (Panel 5.1) shows the maximum extent to which the continents of _____ and _____ have been covered by ice sheets.

2 _____
North America; Europe

The map (Panel 5.2) shows the present position of the ice sheets, in these two continents. They cover much more/less (choose one) of the land, than in 5.1.

3 _____
less

It follows that the climate is warmer/colder today, than formerly.

4 _____
warmer

There has been a succession of four very cold periods - Ice Ages - in the last 1 million years. The name given to these cold climatic periods is an _____.

5 _____
Ice Age

Britain was at one time covered by an ice sheet, north of a line connecting the towns of _____ and _____.

6 _____
Bristol and London

This means that all the lowlands, north of this line, were affected by the _____.

7

ice

The ice sheets carried many rock particles in and on the ice. These rock particles are called _____.

8

moraine

When the ice finally melted, this moraine was deposited. Thus the main work of the ice, in a lowland area, is to _____ the moraine.

9

deposit

Much of the lowland in _____ is covered with these glacial deposits.

10

Britain

In some lowland areas, the ice scraped away the soil, leaving hollows filled with water. In Finland and on the Canadian Shield thousands of lakes were formed in this way. Deposition was the effect, however, the result in most _____ areas.

11

Lowland

Boulder clay, drumlins, eskers and erratics are the main landforms in lowland areas. They are all the result of glacial _____.

12

deposition

When the ice melted the moraine was _____. It often covered the hills and valleys to a considerable depth. In East Anglia it is over 300ft thick.

13 deposited.

These deposits are called boulder clay. East Anglia is covered with a thick layer of _____, which consists of clay with rock fragments.

14

boulder clay

Boulder clay can be seen in many parts of Britain, where new roads are being built. It is made of _____.

15

clay with rock fragments

not clear
fertile of river
Boulder clay is often very fertile. It makes good land, as in East Anglia and in the prairies of Canada. Boulder clay can be found in Britain in _____.

16

farming (wheat, for crops); East Anglia

Lowland Britain, north of a line from Bristol to London, is covered with a layer of _____.

17

boulder clay

Drumlins are relatively small mounds of moraine, which formed beneath the moving ice. Drumlins are made of _____. They were deposited when the ice _____.

18

moraine; melted

Small mounds of moraine are called _____.

19

drumlins

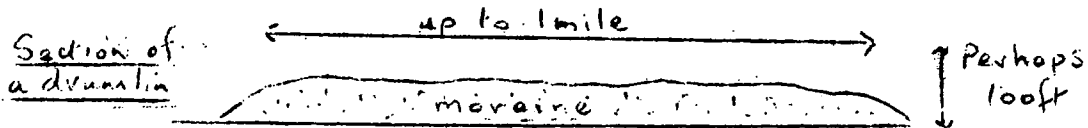

Drumlins can be as high as _____ and as long as _____.
 They are made of _____.

20

100ft; 1mile; moraine

The small, rounded hills and islands, in Panel 5.3, are _____.
 In which part of Northern Ireland was this photograph taken?

21

drumlins; Co: Down

The ice melted very slowly at the edge of the ice sheet. The meltwater resorted the moraine into low ridges of sand and gravel. These ridges are called eskers. Eskers are made of _____ and _____.

22

sand and gravel

The eskers were formed at _____
 by the _____.

23

the edge of the ice sheet; meltwater

Eskers are very useful near towns because _____ and _____ is used in the building industry.

24

sand and gravel

There are many eskers, winding across a lake filled countryside, in large areas of Sweden. Eskers can be found in _____.

25

Sweden

Individual, large boulders were carried on the ice for many miles and were left behind when the ice melted.

They are called erratics. An erratic is a _____.

26

large boulder

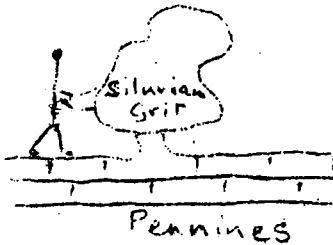

This erratic is made of a rock known as _____. It is resting on the _____.

27

Silurian Grit; Pennines

Near Austwick, in the Pennines, the hillside has many of these _____ resting on it.

28

erratics

Erratics are common in the _____ district in the Pennines.

29

Austwick

Erratics were carried to their present position by the _____.

ice

You have now completed the learning programme.

Answer the questions in Test 5 on page 36.

TEST 5

- 1 What is the Ice Age?
- 2 Name the 2 continents most affected by the Ice Age.
- 3 The work of the ice in a lowland area is mainly _____
- 4 ~~X~~ Copy the following chart and i) list 4 glacial features present in lowland areas ii) what is each of these features made of? iii) where ~~/X/~~ can one example of each be found?

	name of feature	made of	example
1			
2			
3			
4			

Appendix (ix)Analysis and Recording of Programme Structure- Sections 2-5.

ANALYSIS AND RECORDING OF PROGRAMME STRUCTURE

PART 1 Content of Section/Function of Frames (After Franklin 1964) (Compiled from penultimate programme - Appendix(viii))

	Frame Number	No: of frames
1	1 2 3 4 5 6 7 8 9 10 1112 13 1415 1617 181920 2122 232425 2627 2829 3031 323334	3
2	R R R	6
3	T Te T Te T Te ^D Te ^T	1
4	D Te Te Te Te T Te T Te TeTe T	4
5	I T T D	6
6	D D _T Te D Te T T T T T T T	1

KEY
as for Section 1
page 71

PART 2 Programming Technique

Frame Number	Diagram	KEY
1 2 3 4 5 6 7 8 910 1112 13 1415 1617 181920 2122 2324 252627 28 293031 3233 34		KEY

as for Section 1

Figure 5.2

Analysis and Recording of

Programme Structure - Section 2

Figure 5.2

Analysis and Recording of

Programme Structure - Section 3

ANALYSIS AND RECORDING OF PROGRAMME STRUCTURE

PART 1 Content of Section/Function of Frames (After Franklin 1964) (Compiled from the penultimate programme - Appendix(viii))

	Frame Number	No: of frames
	1 2 3 4 5 6 7 8 9 10 11 12 13 14 15 16 17 18 19 20 21 22 23 24 25	1 1 3 1 3 4 4 2 5 1
TEACHING	I I T Te R	
POINT	R T Te R R T Te R R T Te R Te I T T TTe Te	
	Relief on O.S. map slope by contour slope by hachure review of features arête corrie U-shaped valley ribbon lake hanging valley waterfall	

KEY

As for Section 1 page 71

PART 2 Programming Technique

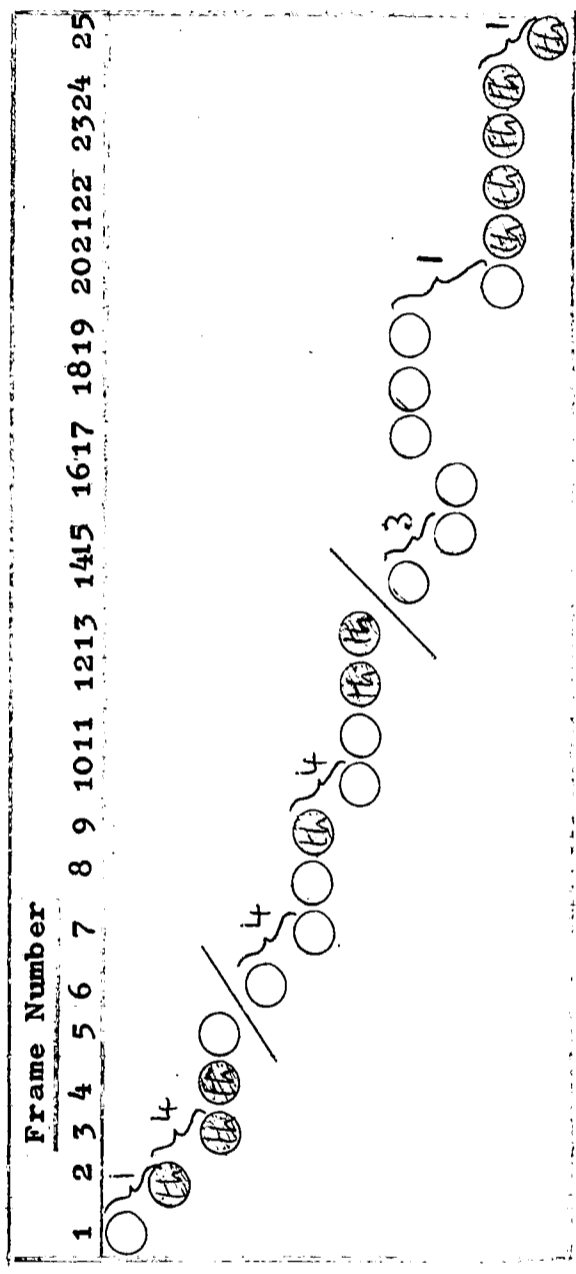

Figure B.2

Analysis and Recording of

Programme Structure - Section 4

ANALYSIS AND RECORDING OF PROGRAMME STRUCTURE

PART 1 Content of Section/Function of Frames(After Franklin 1964) (Compiled from the penultimate programme - Appendix(viii))

	Frame Number							No: of frames																								
	1	2	3	4	5	6	7	8	9	10	11	12	13	14	15	16	17	18	19	20	21	22	23	24	25	26	27	28	29			
TEACHING	I	T	T	D																												
POINTS	Ice Age																															
	2	moraine																														
	3	deposited																														
	4	boulder clay																														
	5	drumlins																														
	6	eskers																														
	7	erratics																														

Figure 5.2

Analysis and Recording of

Programme Structure - Section 5

FIELD TEST 2 Post-Test Analysis (n 51)SECTION 1

<u>Question</u>	<u>Teaching Point</u>	<u>% success</u>
1	{(i) ice sheet	37.25
	{(ii) example	72.55
2	nunatak	78.43
3	{snowfield	54.9
	{corrie	92.16
4	snowline	62.75
5	snow to ice	{pressure 86.27
		{freeze-thaw 74.51
6	glacier	94.12
7	snowfield in Europe	96.08

SECTION 2

1	{(a) movement of ice in glacier	90.2
	{(b) why	84.31
2	{(a) crevasse	76.47
	{(b) causes	{widens 70.59
		{deepens 82.35
{(c) sérac	54.9	
3	{(i) moraine	58.82
	{(ii) explanation	56.86
	{(iii) identify type	35.29
4	example of river glacier	92.16
5	labelled diagram	76.96
6	ex. moraine-dammed lake	92.16

FIELD TEST 2Post-Test Analysis continuedSECTION 3

<u>Question</u>	<u>Teaching Point</u>	<u>% success</u>
1	erode	92.16
2	glaciated highland	98.04
3	(a) { arête	66.67
	{ example	52.94
	(i) corrie	19.61
	(b) { diagram	15.69
	{ example	33.33
(c)	found near mt. peaks	41.18
4	diagram labels	67.84
5	{ description of U-shaped Valley	50
	{ formation of same	80.39
6	(a) ribbon lake	39.22
	(b) example	64.71
	(c) where in the highland area	27.45

SECTION 4

arête	50.98
corrie	54.9
U-shaped valley	66.67
hanging valley	68.63
ribbon lake	76.47

SECTION 5

1	Ice Age	98.04
3	deposition	74.51
4	(i) glacial deposition features	68.14
	(ii) made of	51.96
	(iii) examples	50.98

FIELD TEST 2 - Total Response Error Occurring at Each Frame

(n 51)

SECTION 1			SECTION 2			SECTION 3		
Frame No.	error	no resp.	Frame No.	error	no resp.	Frame No.	error	no resp.
1	2	-	1	2	-	1	0	-
2	{ 12	2	2	2	-	2	4	-
	{ 10	4	3	2	-	3	0*	-
3	2	1	4	{ a 6	-	4	6	1
4	6	2		{ b <u>18</u>	3	5	8	2
5	{ a 2	-	5	2*	-	6	{ 8	1
	{ b 6	1	6	{ <u>43</u>	10	{ <u>37</u>	2	
6	6*	-		{ <u>25</u>	6	{ 6	-	
7	2	-		{ <u>31</u>	9	{ <u>16</u>	-	
8	{ 4	1	7	0*	-	8	{ (i) <u>22</u>	-
	{ 10*	3	8	6	1		{ (ii) <u>39</u>	3
9	<u>24</u>	2	9	{ (i) 4	-	9	{ 6	1
10	{ 2	-		{ (ii) 2	1		{ <u>16*</u>	1
	{ 6	-		{ (iii) 6	1		{ <u>22</u>	1
11	<u>27</u>	2	10	10	1	10	{ <u>13</u>	-
12	<u>25</u>	6	11	2	1	{ <u>31</u>	8	
13	4	-	12	4	1	11	4	-
14	{ a 2	-	13	0	-	12	{ 2	-
	{ b 2	-	14	{ 1 <u>20</u>	-	{ <u>24</u>	1	
{ c 2	-	{ 2 <u>43</u>		7	{ <u>22*</u>	1		
15	<u>16</u>	4	15	{ 2	-	{ 2*	-	
16	{ 8	1	16	{ <u>18</u>	6	{ 2*	-	
	{ 2	-		{ 6*	-	{ 10	1	
17	4	-	{ 10*	2	15	2*	1	
18	10	2	{ 2*	-	16	{ 2*	-	
19	{ 6	1	{ 13*	1	{ 2*	1		
	{ <u>12*</u>	1	17	{ 4	-	17	10*	5
20	<u>20*</u>	7	18	{ <u>16</u>	-	18	2	-
21	{ (i) <u>16</u>	-	19	{ 4	-	19	0*	-
	{ (ii) 6*	-		{ 2	-	20	2*	-
22	<u>22</u>	8	20	{ <u>16</u>	5	20	8*	2
23	6	-	{ <u>20</u>	5	21	{ <u>22</u>	-	
24	0	-	21	4	-	{ 2	-	
25	{ 0*	-	22	{ 0	-	{ 6	1	
	{ 0	-		{ 2	1	{ 6*	2	
26	6	1	23	2	1	23	<u>31</u>	10
27	<u>13</u>	2	24	{ 4	1	24	{ <u>16</u>	1
28	{ 4	1	25	{ 6*	1	{ 0	-	
	{ <u>18</u>	1		25	<u>20*</u>	-	25	<u>16</u>
29	{ (i) <u>13*</u>	5	26	<u>20</u>	2	26	8	-
	{ (ii) <u>35*</u>	10	27	{ <u>18*</u>	2	27	{ 2	-
30	<u>37</u>	9	{ <u>33</u>	5	{ <u>18</u>		1	
31	0	-	28	<u>20</u>	2	28	<u>35</u>	-
32	<u>18</u>	2	29	6*	-	29	4*	-
33	{ <u>13</u>	-	30	{ <u>31</u>	1	30	8	-
	{ 6*	1		{ a <u>33</u>	2	31	6	1
34	{ <u>22*</u>	1	{ b <u>18</u>	3	32	4*	-	
			31	10	-			
			32	<u>27</u>	6			
			33	<u>13*</u>	-			
			34	2	1			

47 responses
in 34 frames50 responses in
44 frames47 responses in
32 framesKEY

* Key frame

— more than 10% error

FIELD TEST 2 - Total Response Error (Continued) (n 51)

SECTION 4			SECTION 5		
Frame No.	error	no resp.	Frame No.	error	no resp.
1	{ 0 6	- 1	1	{ 0 0	- -
2	{ 2 4	- 1	2	2	1
3	<u>24</u>	6	3	4	1
4	2	-	4	2	-
5	4	-	5	<u>13</u>	3
6	{ 0 0	- -	6	4	-
7	8	-	7	<u>22</u>	-
8	{ 10 <u>13</u> <u>31</u>	2 2 11	8	<u>13*</u>	1
9	{ <u>27*</u> <u>27*</u>	5 6	9	<u>12</u>	2
10	<u>18</u>	3	10	<u>12</u>	-
11	{ 4 6	1 1	11	<u>18</u>	3
12	<u>25</u>	-	12	4	1
13 ^(a)	<u>20*</u>	4	13	4	-
13 ^(b)	<u>67*</u>	10	14	6	2
14	8	3	15	{ <u>39</u> 8*	4 1
15	{ 8 <u>37</u>	2 6	16	10*	-
16	{ 8* 6*	- -	17	{ 10* <u>18</u>	- 1
17	{ 2 10	- 1	18	0	-
18	{ 2 6	1 1	19	{ 2 0 2	- - -
19	{ <u>55*</u> <u>61*</u>	3 7	20	{ 8 4*	2 -
20	<u>22</u>	1	21	0*	-
21	{ <u>13</u> <u>37</u>	1 5	22	{ <u>12</u> <u>22</u>	2 2
22	8	-	23	6	1
23	10	-	24	8*	-
24	{ <u>12*</u> <u>13*</u>	1 4	25	2	1
25	10	-	26	{ 0 2	- -
			27	6*	1
			28	<u>12*</u>	2
			29	2	-

KEY

* Key frames

— more than 10% error

40 responses in
25 frames

38 responses in
29 frames

FIELD TEST 2Retention Test Analysis

(n 49)

SECTION 1

<u>Question</u>	<u>Teaching Point</u>	<u>% success</u>
1	{ (i) ice sheet	75.51
	{ (ii) example	38.78
2	nunatak	63.27
3	iceberg	83.67
4	{ snowfield	36.73
	{ corrie	87.76
5	snowline	71.43
6	{ avalanche	87.76
	{ glacier	65.31
7	snowfield in Europe	81.63

SECTION 2

1	{ (a) movement of ice	65.31
	{ (b) reason	61.22
2	crevasse	65.31
	sérac	18.37
3	cause of crevasse	{ widens 30.61
		{ deepens 38.78
4	{ (i) cause of rock shattering	36.73
	{ (ii) moraine	71.43
	{ (iii) lateral moraine	36.73
5	river glacier	46.94
6	labelled diagram	35.71
7	ex. moraine dammed lake	57.14

FIELD TEST 2Retention Test Analysis continuedSECTION 3

<u>Question</u>	<u>Teaching Point</u>	<u>% success</u>	
1	erode	38.78	
2	glaciated highland	75.51	
3	(a) { arête	30.61	
	{ example	12.24	
	(b) { (i) corrie	39.8	
	{ diagram	12.24	
	{ (ii) example	14.29	
(c)	near mt. peaks	61.22	
4	(a)	U-shaped valley	67.35
	(b) { description	35.71	
	{ diagram	21.43	
	(c)	glacial features in it	46.26
	(d)	how differs from river valley	30.61
5	(a)	ribbon lake	65.31
	(b)	example	73.47

SECTION 4

arête	30.61
corrie	22.45
U-shaped valley	51.02
*(ommission due to typing error on question paper)	
ribbon lake	91.84

FIELD TEST 2Retention Test Analysis continuedSECTION 5

<u>Question</u>	<u>Teaching Point</u>	<u>% success</u>	
1	deposit	28.57	
2	boulder clay	34.69	
3	eskers {	example	30.61
		sand & gravel	38.78
		resorting	2.04
4	drumlins {	small	67.35
		moraine	53.06
		example	12.24
5	erratics	18.37	
	example	12.24	

Appendix (xi)

FINAL VALIDATION TEST DATA

(n 34)

Pupil	AH ₄	School Geog.%	Programme Achievement (Total 55)		
			Pre-Test	Post-Test	Retention Test
1	107	64	10	53	43
2	68	28	8	42.5	32.5
3	87	73	9	44	41.5
4	93	39	4	46.5	18.5
5	71	66	3	40.5	17.5
6	88	15	1	34.5	18.5
7	103	86	7	53	42
8	96	56	11	50	42.5
9	92	14	6	34	18.5
10	83	20	3	30	14
11	87	17	2	43	31
12	75	63	5	35	19.5
13	87	68	6	51.5	34.5
14	77	8	3	37.5	29
15	55	33	4	20	20
16	106	87	6	52.5	43.5
17	96	61	6	49	20
18	90	61	8	44	30
19	76	8	2	31	17.5
20	89	34	6	39	21
21	100	48	5	50.5	41.5
22	81	73	11	49.5	39
23	85	88	16	53.5	50
24	100	88	10	46	36
25	99	33	6	38	27.5
26	90	44	5	35.5	25
27	95	73	11	46.5	27
28	102	43	10	46.5	36
29	87	37	3	39.5	28
30	70	42	7	40	23.5
31	77	34	7	34.5	24
32	92	-	5	39.5	24
33	90	5	1	29.5	13
34	75	39	2	36	26
Σ	2969	1548	209	1415.5	975
\bar{x}	87.32	46.91	6.15	41.63	28.67
range	55-107	5-88	1-16		
S.D.	11.71	25.04			

FINAL VALIDATION - Pupil/Post-Test Score (n 34)

Pupil	SECTIONS					PROGRAMME
	1	2	3	4	5	TOTAL
	(10)*	(15)	(15)	(5)	(10)	(55)
1	10	14	14	5	10	53
2	10	14	6.5	2	10	42.5
3	10	9	11.5	5	8.5	44
4	9	14	12	2	9.5	46.5
5	8	13	11.5	2	6	40.5
6	9	10	8	3	4.5	34.5
7	10	14	15	4	10	53
8	8	13	14	5	10	50
9	10	8	9.5	1	5.5	34
10	6	11	10.5	1	1.5	30
11	9	15	11.5	1	6.5	43
12	8	12	8.5	1	5.5	35
13	10	14	13	5	9.5	51.5
14	9	12	6.5	1	9	37.5
15	8	1	3.5	3	4.5	20
16	10	15	13.5	4	10	52.5
17	9	15	13.5	2	9.5	49
18	8	12	11	4	9	44
19	9	9	8.5	1	3.5	31
20	9	13	8	3	6	39
21	10	12	12.5	2	14	50.5
22	10	15	11.5	5	8	49.5
23	10	15	13.5	5	10	53.5
24	10	13	14.5	2	6.5	46
25	6	14	10	2	6	38
26	8	13	5.5	2	7	35.5
27	10	14	11	4	7.5	46.5
28	9	15	10.5	4	8	46.5
29	10	10	12.5	2	5	39.5
30	8	12	10.5	2	7.5	40
31	8	14	4.5	1	7	34.5
32	9	11	12	2	5.5	39.5
33	8	7	9	-	5.5	29.5
34	10	8	8	3	7	36
TOTAL	305	411	355.5	91	253	1415.5

() section maximum score

FINAL VALIDATION - Pupil/Retention Test Score (n 34)

Pupil	SECTIONS					PROGRAMME
	1	2	3	4	5	TOTAL
	(10)*	(15)	(15)	(5)	(10)	(55)
1	9	12	12	5	5	43
2	8	9	9	1	5.5	32.5
3	7	14	11.5	5	4	41.5
4	5	6	5.5	2	-	18.5
5	5	3	6.5	1	2	17.5
6	8	0	6.5	2	2	18.5
7	8	14	10	5	5	42
8	9	10	15	5	3.5	42.5
9	3	4	8.5	2	1	18.5
10	6	3	4	-	1	14
11	8	14	6.5	-	2.5	31
12	6	7	3.5	1	2	19.5
13	8	9	10	5	2.5	34.5
14	7	10	6.5	1	4.5	29
15	7	4	4.5	2	2.5	20
16	9	15	11.5	3	5	43.5
17	6	7	6	-	1	20
18	8	5	11	4	2	30
19	4	7	6.5	-	-	17.5
20	6	4	6	2	3	21
21	10	13	8.5	3	7	41.5
22	8	12	10	4	5	39
23	9	15	13	5	8	50
24	6	10	11.5	3	5.5	36
25	3	10	9	2	3.5	27.5
26	6	7	7	3	2	25
27	7	8	7	2	3	27
28	10	13	8	2	3	36
29	4	10	8.5	2	3.5	28
30	7	4	10.5	1	1	23.5
31	7	12	2	1	2	24
32	6	7	7	2	2	24
33	3	7	3	-	-	13
34	6	7	10	1	2	26
TOTAL	229	292	275.5	77	101.5	975

() section maximum score.

FINAL VALIDATION - Pupil/Frame Response Error Scores (n 34)

Pupil	SECTIONS					Programme Total
	1	2	3	4	5	
1	4	3	2	6	-	15
2	-	-	2	8	2	12
3	-	-	-	1	-	1
4	1	-	5	7	4	17
5	1	4	3	3	1	12
6	-	-	2	4	-	6
7	-	2	4	3	1	10
8	-	2	5	3	2	12
9	1	2	3	6	6	18
10	1	4	1	-	-	6
11	-	-	3	2	1	6
12	2	8	5	6	4	25
13	-	1	1	2	3	7
14	-	-	1	1	1	3
15	3	9	16	11	12	51
16	3	2	4	5	-	14
17	3	5	4	8	1	21
18	-	-	1	-	2	3
19	5	9	13	2	6	35
20	-	-	1	3	-	4
21	-	-	2	-	-	2
22	-	-	-	-	-	-
23	-	-	-	-	5	5
24	3	3	2	7	1	16
25	1	2	4	1	2	10
26	2	6	6	-	-	14
27	-	2	4	15	4	25
28	-	-	3	-	-	3
29	1	3	5	-	2	11
30	3	2	2	6	2	15
31	-	-	-	-	-	-
32	-	3	2	6	-	11
33	2	4	3	5	1	15
34	2	5	5	13	4	29
TOTAL	38	81	144	134	67	434

FINAL VALIDATION - Frame Response Errors (n 34)

SECTION 1		SECTION 2		SECTION 3		SECTION 4		SECTION 5	
f	errors	f	errors	f	errors	f	errors	f	errors
1	2	1	1	1	0	1	7	1	0
2	{ 0	2	0*	2	1	2	{ 5	2	{ 0
3	1	{ (a) 0		3	1*		{ 4	3	0
4	0	{ (b) 5		4	2*	3	3	4	0*
5	{ 1	{ (c) 6		5	3	4	3	5	1
6	{ 0	4	1*	6	{ 2	5	3	6	2
{ (a) 7		5	3*	7	{ 1	6	{ 3	7	3
{ (b) 5		6	1	8	2	7	{ 4	8	5*
7	0*	7 { A 2		9	{ 0	8	{ 9	9	0
8	0	{ B 1		10	{ 1	9	{ 10	10	3
9	{ 0*	8	0	11	{ 1	{ (a) 7*		11	1
10	1	9	0	12	{ 1*	{ (b) 16*		12	1
11	2*	10	0	13	{ 0*			13	0
12	0*	11	2	14	{ 0*	10	{ 6*	14	0
13	1	12	{ 1	15	{ 0*	11	{ 7*	15	{ 2*
14	{ 0	13	{ 3	16	{ 1*	12	{ 0	16	3
15	0	14	{ 0*	17	{ 0*	13	{ 8*	17	0
16	0	15	{ 1*	18	{ 2*	14	{ 8	18	{ 0
17	0	16	{ 0*	19	{ 9	15	{ 4*	19	{ 0
18	6*	17	{ 0	20	{ 2	16	{ 2*	20	{ 4*
19	0*	18	{ 0	21	{ 1*	17	4	21	{ 1
20	0	19	{ 0	22	{ 5*	18	0	22	{ 2
21	2*	20	{ 4*	23	{ 6	19	2	23	{ 7
22	1	21	{ 0*	24	{ 1*	20	{ 4*	24	{ 2*
23	{ 0*	22	{ 3*	25	{ 0*	21	{ 6*	25	0
24	{ 0	23	{ 4	26	{ 5*	22	{ 4*	26	0*
25	0	24	{ 2	27	{ 4	23	{ 5*	27	0*
26	1	25	{ 3	28	{ 2*	24	{ 4	28	{ 3*
27	0*	26	{ 1	29	{ 4	25	{ 2	29	{ 1
28	{ 1	27	{ 1	30	{ 1*	26	{ 3	30	{ 0
29	0	28	{ 1	31	{ 2*	27	{ 6	31	{ 1
30	1	29	{ 0	32	{ 1	28	{ 4	32	{ 1
31	0*	30	{ 2	33	{ 1	29	{ 1	33	{ 1
32	{ 1	31	{ 3	34	{ 3*	30	{ 2	34	{ 0
33	1	32	{ 8	35	{ 5*	31	{ 1	35	{ 3
34	1	33	{ 3	36	{ 8*	32	{ 7	36	{ 1
35	1	34	{ 2	37	{ 7	33	{ 1	37	{ 1
36	1	35	{ 0	38	{ 1*	34	{ 1	38	{ 1
37	1	36	{ 7	39	{ 1*	35	{ 1	39	{ 0
38	1	37	{ 3*	40	{ 2*	36	{ 1	40	{ 1
39	1	38	{ 1*	41	{ 1	37	{ 1	41	{ 1
40	1	39	{ 1	42	{ 4	38	{ 1	42	{ 1
41	1	40	{ 1	43	{ 1	39	{ 1	43	{ 1
42	1	41	{ 1	44	{ 4	40	{ 1	44	{ 0
43	1	42	{ 1	45	{ 1	41	{ 1	45	{ 3
44	1	43	{ 1	46	{ 5	42	{ 1	46	{ 1
45	1	44	{ 1	47	{ 1	43	{ 1	47	{ 2
46	1	45	{ 1	48	{ 1	44	{ 1	48	{ 8
47	1	46	{ 1	49	{ 1	45	{ 1	49	{ 8
48	1	47	{ 1	50	{ 0	46	{ 1	50	{ 8
49	1	48	{ 1	51	{ 0	47	{ 1	51	{ 8
50	1	49	{ 1	52	{ 0	48	{ 1	52	{ 8
51	1	50	{ 1	53	{ 0	49	{ 1	53	{ 8
52	1	51	{ 1	54	{ 0	50	{ 1	54	{ 8
53	1	52	{ 1	55	{ 0	51	{ 1	55	{ 8
54	1	53	{ 1	56	{ 0	52	{ 1	56	{ 8
55	1	54	{ 1	57	{ 0	53	{ 1	57	{ 8
56	1	55	{ 1	58	{ 0	54	{ 1	58	{ 8
57	1	56	{ 1	59	{ 0	55	{ 1	59	{ 8
58	1	57	{ 1	60	{ 0	56	{ 1	60	{ 8
59	1	58	{ 1	61	{ 0	57	{ 1	61	{ 8
60	1	59	{ 1	62	{ 0	58	{ 1	62	{ 8
61	1	60	{ 1	63	{ 0	59	{ 1	63	{ 8
62	1	61	{ 1	64	{ 0	60	{ 1	64	{ 8
63	1	62	{ 1	65	{ 0	61	{ 1	65	{ 8
64	1	63	{ 1	66	{ 0	62	{ 1	66	{ 8
65	1	64	{ 1	67	{ 0	63	{ 1	67	{ 8
66	1	65	{ 1	68	{ 0	64	{ 1	68	{ 8
67	1	66	{ 1	69	{ 0	65	{ 1	69	{ 8
68	1	67	{ 1	70	{ 0	66	{ 1	70	{ 8
69	1	68	{ 1	71	{ 0	67	{ 1	71	{ 8
70	1	69	{ 1	72	{ 0	68	{ 1	72	{ 8
71	1	70	{ 1	73	{ 0	69	{ 1	73	{ 8
72	1	71	{ 1	74	{ 0	70	{ 1	74	{ 8
73	1	72	{ 1	75	{ 0	71	{ 1	75	{ 8
74	1	73	{ 1	76	{ 0	72	{ 1	76	{ 8
75	1	74	{ 1	77	{ 0	73	{ 1	77	{ 8
76	1	75	{ 1	78	{ 0	74	{ 1	78	{ 8
77	1	76	{ 1	79	{ 0	75	{ 1	79	{ 8
78	1	77	{ 1	80	{ 0	76	{ 1	80	{ 8
79	1	78	{ 1	81	{ 0	77	{ 1	81	{ 8
80	1	79	{ 1	82	{ 0	78	{ 1	82	{ 8
81	1	80	{ 1	83	{ 0	79	{ 1	83	{ 8
82	1	81	{ 1	84	{ 0	80	{ 1	84	{ 8
83	1	82	{ 1	85	{ 0	81	{ 1	85	{ 8
84	1	83	{ 1	86	{ 0	82	{ 1	86	{ 8
85	1	84	{ 1	87	{ 0	83	{ 1	87	{ 8
86	1	85	{ 1	88	{ 0	84	{ 1	88	{ 8
87	1	86	{ 1	89	{ 0	85	{ 1	89	{ 8
88	1	87	{ 1	90	{ 0	86	{ 1	90	{ 8
89	1	88	{ 1	91	{ 0	87	{ 1	91	{ 8
90	1	89	{ 1	92	{ 0	88	{ 1	92	{ 8
91	1	90	{ 1	93	{ 0	89	{ 1	93	{ 8
92	1	91	{ 1	94	{ 0	90	{ 1	94	{ 8
93	1	92	{ 1	95	{ 0	91	{ 1	95	{ 8
94	1	93	{ 1	96	{ 0	92	{ 1	96	{ 8
95	1	94	{ 1	97	{ 0	93	{ 1	97	{ 8
96	1	95	{ 1	98	{ 0	94	{ 1	98	{ 8
97	1	96	{ 1	99	{ 0	95	{ 1	99	{ 8
98	1	97	{ 1	100	{ 0	96	{ 1	100	{ 8
99	1	98	{ 1			97	{ 1		
100	1	99	{ 1			98	{ 1		
101	1	100	{ 1			99	{ 1		
102	1					100	{ 1		
103	1								
104	1								
105	1								
106	1								
107	1								
108	1								
109	1								
110	1								
111	1								
112	1								
113	1								
114	1								
115	1								
116	1								
117	1								
118	1								
119	1								
120	1								
121	1								
122	1								
123	1								
124	1								
125	1								
126	1								
127	1								
128	1								
129	1								
130	1								
131	1								
132	1								
133	1								
134	1								
135	1								
136	1								
137	1								
138	1								
139	1								
140	1								
141	1								
142	1								
143	1								
144	1								
145	1								
146	1								
147	1								
148	1								
149	1								
150	1								
151	1								
152	1								
153	1								
154	1								
155	1								
156	1								
157	1								
158	1								
159	1								
160	1								
161	1								
162	1								
163	1								
164	1								
165	1								
166	1								
167	1								
168	1								
169	1								
170	1								
171	1								
172	1								
173	1								
174	1								
175	1								
176	1								
177	1								
178	1								
179	1								
180	1								
181	1								
182	1								
183	1								
184	1								
185	1								
186	1								
187	1								
188	1								
189	1								
190	1								
191	1								
192									

FINAL VALIDATION - Summary of Frame Response Errors (n 34)

Key Frame Response Errors

Section	Total Poss. Key Responses	Key Resp. Errors	% Key Resp. Errors
1	374	11	2.94
2	408	18	4.41
3	714	41	5.74
4	340	65	19.11
5	374	18	4.81
Total	2,210	153	6.92

Total Frame Response Errors

Section	No. of frames	No. of responses	Total Poss. responses	Response errors	% response errors
1	28	39	1326	38	2.87
2	32	47	1598	81	5.07
3	30	53	1802	114	6.33
4	21	29	986	134	13.59
5	33	52	1768	67	3.79
Total	144	220	7480	434	5.80

TESTS USED IN THE COMPARATIVE EXPERIMENT (with mark schemes)PRE-TEST, POST-TEST and RETENTION TEST Time allowed 30 minutes

- | | |
|---|------------|
| 1 a) Name a mountain range in Europe which has permanent ice and snow. | 1 |
| b) The area on the mountains where the snow collects is called the _____. | 1 |
| c) In spring there is danger of the snow falling from the mountainside as an _____. Usually, however, the snow changes to ice and moves down the mountainside as a _____. | 1 |
| 2 a) Loose rock, which shatters from the mountain peaks onto the ice, is called _____. This material helps the ice to _____ the valley side. | 1 |
| b) Name a river which starts as a glacier. | 1 |
| c) Explain how a moraine-dammed lake is formed. | 2 |
| d) Give an example of such a lake. | 1 |
| 3 a) Describe a corrie. | 2 |
| b) Draw a labelled diagram which explains how it was formed. | 2 |
| c) A glaciated valley is ____-shaped. Describe it. Give one example. Name 3 features which may be found in it. | 1+1
1+3 |
| d) What is a ribbon lake? Where is it found? Name one. | 1+1+1 |
| 4 a) Much of lowland Britain is covered with a glacial deposit called _____. | 1 |
| b) (i) Name one feature resulting from glacial deposition. | 1 |
| (ii) Describe and illustrate it. | 2+1 |
| (iii) Explain how it was formed. | 1 |
| (iv) Give one example. | 1 |

TOTAL 30

G.C.E. QUESTIONSGLACIATION THEORY

Time allowed 30 minutes

Choose 2 landscape features which are the result of glacial erosion and 1 feature resulting from glacial deposition. For EACH a) Name the feature 3(1+1) and locate a particular example b) With the aid of 3(1) diagrams, describe and give reasons for the 4+4+3 characteristics of the features you have named.

TOTAL 20MAP INTERPRETATION

Time allowed 15 minutes

(O.S. map - south west corner of part of Snowdon 1 inch sheet.)

Find evidence from the O.S. map to support the statement that 'this area of Snowdonia has been glaciated'.

(1 mark for each of 5 glacial features illustrated)

TOTAL 5

Appendix (xiii)

Criterion Test Results used in the Comparative ExperimentGROUP I

Pupil	AH ₄ (Raw scores)	AGE in March 1970 yrs/months	Pre-Test (maximum score) 30	Post-Test (maximum score) 30	Retention (maximum score) 30	G.C.E.	
						Theory 20	O.S. 5
1	87	13-8 mnths	2	11	9	10	0
2	94	13-9	2	23	18	15	0
3	88	14-0	2	14	10	16	4
4	106	14-5	8	30	29	19	4
5	68	14-4	3	10	10	6	0
6	80	13-8	2	13	10	3	1
7	93	14-0	4	15	16	13	1
8	92	13-10	3	23	16	11	0
9	65	13-10	1	9	8	7	0
10	73	14-1	3	19	12	9	0
11	86	14-6	2	18	16	6	2
12	74	14-2	4	25	21	-	-
13	99	14-6	3	26	19	18	1
14	80*	14-4	3	12	15	12	1
15	95	14-1	1	16	12	17	1
16	84	14-6	2	27	27	20	3
17	98	14-1	4	26	26	19	5
18	94	14-5	4	29	25	20	4
19	87	13-10	2	14	13	14	2
20	69	13-9	0	12	7	4	2
21	69	13-9	1	12	11	13	-
22	76	14-4	4	25	17	18	1
23	85	13-7	5	20	-	6	1
24	73	14-4	3	15	15	13	0
25	77	14-4	5	14	10	9	1
26	85	13-8	2	8	7	2	0
Σ	2177	365-9	75			300	34
n	26	26	26	26	25	25	24
\bar{x}	83.73		2.88			12	1.42
S.D.	10.88		1.63				

* pupil 14 was absent for the AH₄ test and has been given the mean score for the experimental population.

Criterion Test ResultsGROUP II

Pupil	AH ₄ (Raw scores)	AGE in March 1970 yrs/months	Pre-Test (maximum score) 30	Post-Test (maximum score) 30	Retention (maximum score) 30	G.C.E.	
						Theory 20	O.S. 5
1	97	14-4	16	29	28	20	5
2	61	14-1	1	27	20	9	2
3	86	13-7	5	17	15	11	1
4	99	14-3	15	28	28	20	4
5	94	14-1	3	26	23	16	4
6	77	14-5	3	22	23	17	3
7	47	13-7	3	9	7	5	2
8	71	13-9	2	4	-	10	0
9	87	14-3	3	30	23	16	4
10	51	13-8	4	21	19	-	0
11	85	14-5	2	20	21	11	2
12	76	14-4	4	21	14	16	1
13	89	14-3	1	15	-	11	2
14	84	13-9	4	27	20	20	3
15	70	14-0	3	20	-	10	2
16	70	14-4	2	7	7	9	0
17	79	14-1	4	26	23	19	4
18	73	14-0	1	19	13	14	0
19	88	13-8	5	28	27	15	3
20	65	14-2	3	15	12	9	0
21	63	13-7	2	28	23	13	5
22	111	14-5	1	17	20	16	3
23	63	14-0	1	23	22	16	3
24	76	14-5	2	16	13	15	1
25	80	14-0	3	20	17	16	5
26	74	13-10	2	19	19	14	2
Σ	2016	365-3	95			348	61
n	26	26	26	26	23	25	26
\bar{x}	77.54		3.65			13.92	2.35
S.D.	14.72		3.69				

Criterion Test ResultsGROUP III

Pupil	AH ₄	AGE in March 1970 yrs/months	Pre-Test (Maximum score) 30	Post-Test (maximum score) 30	Retention (maximum score) 30	G.C.E.	
						Theory 20	O.S. 5
1	78	13-7	3	16	16	15	4
2	67	14-0	2	20	14	15	3
3	91	14-2	2	29	24	-	-
4	63	13-9	5	23	17	10	0
5	95	14-3	3	17	15	20	4
6	91	14-3	2	15	7	18	3
7	91	14-1	12	28	-	16	3
8	84	13-11	0	21	14	19	3
9	68	13-10	3	20	11	14	1
10	80	14-6	2	19	18	-	-
11	91	13-11	1	11	7	15	4
12	60	14-6	3	21	14	13	1
13	87	13-7	4	25	18	13	3
14	81	13-7	4	18	15	19	2
15	80	14-3	4	17	13	14	2
16	72	14-2	3	17	16	12	2
17	98	14-5	2	13	12	19	2
18	59	14-4	2	7	5	9	0
19	91	14-4	1	21	18	19	1
20	72	14-6	2	14	6	9	0
21	79	14-0	3	23	20	20	3
22	78	14-1	3	26	21	19	3
23	93	13-8	2	19	12	9	4
24	105	13-7	4	26	27	-	-
25	66	13-8	2	13	6	-	-
26	57	14-3	2	13	11	5	1
Σ	2077	365-2	76			322	49
n	26	26	26	26	25	22	22
\bar{x}	79.88		2.92			14.64	2.23
S.D.	13.14		2.15				

TOTAL SCORES FOR ALL GROUPS

Σ	6270	1096-4	246			970	144
n	78	78	78			72	72
\bar{x}	80.38	14-1	3.15			13.47	2
S.D.	13.10		3.06				

Post-Test and Retention Test Gain Scores for the 3 Teaching Groups

POST-TEST GAIN SCORES			RETENTION TEST GAIN SCORES		
Group 1	Group 2	Group 3	Group 1	Group 2	Group 3
9	13	13	7	12	13
21	26	18	16	19	12
12	12	27	8	10	22
22	13	18	21	13	12
7	23	14	7	20	12
11	19	13	8	20	5
11	6	16	12	4	14
20	2	21	13	20	8
8	27	17	7	15	16
16	17	17	9	19	6
16	18	10	14	10	11
21	17	18	17	16	14
23	14	21	16	5	11
9	23	14	12	19	9
15	17	13	11	12	13
25	5	14	25	22	10
22	22	11	22	9	3
25	18	5	21	21	17
12	23	20	11	19	4
12	12	12	7	21	17
11	26	20	10	11	18
21	16	23	13	14	10
15	22	17	12	17	23
12	14	22	5		4
9	17	11	5		9
6	17	11			
Σ 391	439	416	Σ 309	348	293
n 26	26	26	n 25	23	25
\bar{x} 15.04	16.88	16	\bar{x} 12.36	15.13	11.72
S.D. 5.94	6.38	4.86	S.D. 5.54	5.27	5.28

Total Scores for the 3 Teaching Groups

Post Test Gains	Retention Test Gains
Σ 1246	Σ 950
n 78	n 73
\bar{x} 15.97	\bar{x} 13.01

A Learning Programme in Geography

GLACIATION
by
E. SHEPHERD

DEPARTMENT OF EDUCATION-DURHAM UNIVERSITY

ABOUT THIS BOOKLET

This is a learning programme, which will teach you about glaciation. The programme is divided into five sections. Each section, which is followed by a short test, will take you one lesson to complete.

The sections are sub-divided into small parts called frames. You are asked to read the first frame and answer the question set in it. Write your answer on the answer sheet provided before moving on to the next frame. The next frame gives you the correct answer and a new piece of information.

From time to time the frames refer you to maps, photographs etc., which are separate from this booklet. They are called Panels.

HOW TO USE THE PROGRAMMED SECTIONS OF THIS BOOK

Frame 1 First cover all the frames on this page except this one. Use the card provided in the book. The frames should be covered with _____. When you can complete this sentence move on to the next frame.

Frame 2

card

The correct answer to the question set is always given at the top of the next frame. The correct answer to frame 1 was _____.

Frame 3

card

Do not write on this page but on the answer sheet provided. All answers must be written on the _____.

Frame 4

answer sheet

You will learn more from this programme if you always answer the question before moving on to the next frame.

Always answer the question f _____.

Frame 5

first

The next frame gives the correct answer. Check your answer and mark it with a ✓ or X. There is a copy of an answer sheet below which has the answers entered. Some of these have been marked. Mark the answer to frame 4.

Frame	answer	✓ or X
1	card	✓
2	card	✓
3	answer sheet	✓
4	first	

GLACIATION PRE-TEST

Answer all questions.

All answers to be written on the answer sheet provided.

TEST 1

- 1 (i) A thick layer of ice and snow which covers a large lowland area is an _____.
- (ii) One of these can be found in _____.
- 2 What is a nunatak?
- 3 (i) What is an iceberg?
- (ii) Why is it impossible for ships to see most of it?
- 4 In cold mountainous areas permanent snow collects in large areas called _____ and much smaller depressions (hollows) called _____.
- 5 Name a mountain range which has permanent snow.
- 6 The snow may fall quickly from the mountainside as an _____ or much more slowly, in the form of ice, as a _____.

SECTION 1

Ice Sheets and Glaciers

1 Snow tends to accumulate where the temperature is above/below freezing point for long periods of the year.

2

below

There are large areas of the world, near the N _____ P _____ and the _____, where the temperature is always cold.

3

North Pole, South Pole

These areas are permanently covered by _____ and _____.

4

snow; ice

A thick layer of ice covering a large lowland area is called an ice sheet.



In this diagram A is an _____.

5

ice sheet

An ice sheet is a _____ layer of ice which covers a large _____ area.

6

thick, lowland

Use your atlas, page 2, to find an ice sheet a) near the North Pole, b) near the South Pole. Remember the ice sheet is on land.

7

a) Greenland b) Antarctica

The biggest ice sheet in the Northern Hemisphere is in _____.

8

Greenland

Mountain peaks which project above the ice are called nunataks.

What is A in the diagram?



9

a nunatak

In this diagram A is an _____. A nunatak is also shown. Describe it in your own words.

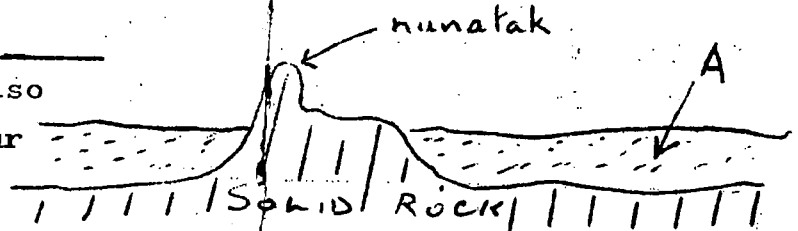

10

A ice sheet; an area of rock projecting above the ice.

From the centre of the Greenland ice sheet, the ice moves slowly towards the sea. Along the coast the action of the waves causes large blocks of ice to _____ and float away.

11

break off

These large blocks of ice are called _____.

12

icebergs

Icebergs are able to float because ice is lighter than water. When water freezes it increases its volume by about 10%.

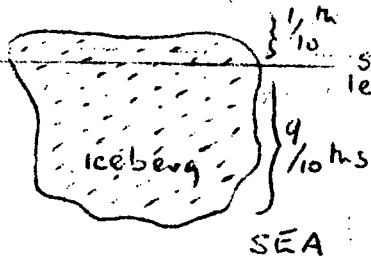

The diagram shows an iceberg in the sea. How much of it can be seen by the approaching ship?

13

1/10th or 10%

Many liners and cargo ships use the busy shipping lanes between Europe and North America. Near North America there is a danger to these ships from icebergs. Where are these icebergs floating from? (Use your atlas page 2 if necessary),

14

Greenland

Read the account, in Panel 1.1, of the fate of a famous ship, and then complete the following sentence: While the _____ was on its maiden voyage to North America it struck an _____, near the island of _____, and sank.

15

Titanic; iceberg; Newfoundland

Because the temperature decreases as you ascend (go up) a mountain, permanent snow will be found at the _____ of many mountains.

16

top

If the mountain is _____ enough permanent snow will be present, even near the Equator.

17

high

The area where the snow accumulates, at the top of the mountain, is called the snowfield. In this diagram A is a _____.

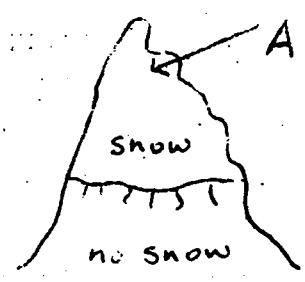

18

snowfield

Now look at the photograph (Panel 1.1). On it the large areas where the snow is collecting, are labelled S. The area marked S is a _____.

19

snowfield.

This photograph was taken in the mountain range called the Alps. There is a snowfield in the _____.

20

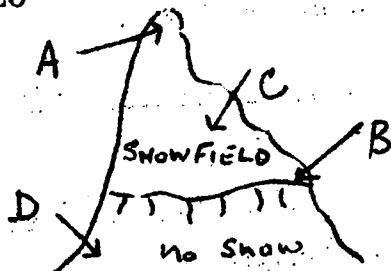

Alps

The lower edge of the snowfield is called the snowline. Which letter on the diagram indicates the snowline?

21

B

On the mountainside there is always snow above the _____.

22

snowline

The snow is deepest in the hollows near the mountain peaks. These hollows are called corries. In Panel 1.2 the letter C indicates a number of _____.

23

corries

The hollows, in which the snow collects, are called _____. They can be found near the _____.

24

corries; mountain peaks

Each new snow shower adds to the snow lying on the mountain slopes. If too much snow piles up on a steep slope it will begin to slide or avalanche down the mountainside. An _____ is most likely to occur where the slopes are _____.

25

avalanche; steep

The snow, at first, has many air pockets between the snowflakes. Soon, however, the air is forced out and the snow changes to _____.

26

ice

This ice flows down the mountain slopes, but it flows much more slowly than rainwater in the streams of warmer areas. Ice, like water, _____ down the mountain side.

27

flows

The water flows as a river, the ice as a glacier. The 'river' of ice labelled G on the photograph (Panel 1.2) is a _____.

28

glacier

Now, using Panel 1.2, we will see what we have learnt about the photograph so far. In this mountainous area snow is collecting in the large area S, a _____, and in the smaller areas C, which are _____. The snow may fall down a very steep slope as an _____ but, more usually, changes to ice and flows down a valley as a _____, as at G.

snowfield; corries; avalanche; glacier.

You have now completed section 1.
Answer the questions in Test 1 on page 8.

TEST 1

Answer all questions. Answers to be written on the back of your Section 1 answer sheet.

- 1(i) A thick layer of ice and snow which covers a large lowland area is an _____ .
- (ii) One of these can be found in _____ .
- 2 What is a nunatak?
- 3(i) What is an iceberg?
- (ii) Why is it impossible for ships to see most of it?
- 4 In cold mountainous areas permanent snow collects in large areas called _____ and much smaller depressions (hollows) called _____ .
- 5 Name a mountain range which has permanent snow.
- 6 The snow may fall quickly from the mountain side as an _____ or move much more slowly, in the form of ice, as a _____ .

If time permits, answer this problem in your rough books.

The table shows the actual height of the snowline on three mountains:

Alps	46°N	9,000ft
Himalayas	30°N	16,000ft
Mt. Kilimanjaro	3°N	18,000ft

- a) Is the snowline higher or lower on the mountain side as the equator is approached?
- b) All these mountain ranges have a permanent snowfield. Which one is in Europe?

NAME _____

TIME _____

Frame	Answer	✓ or ✗	Frame	Answer	✓ or ✗
1			17		
2			18		
			19		
3			20		
4			21		
5			22		
			23		
6	a)		24		
	b)				
7			25		
8			26		
			27		
10			28		
11					
12					
13					
14					
15					
16					

TIME _____

TEST 1

1 (i)

(ii)

2

3 (i)

(ii)

4 {

5

6 {

PANEL I:2



SECTION 5 Glacial Features in a Lowland Area

33 frames

1 The map (Panel 5.1) shows the maximum extent to which the continents of _____ and _____ have been covered by ice sheets.

2

North America; Europe

Panel 5.2 shows the present position of the ice sheets. They now cover much more/less (choose one) of the land than in Panel 5.1.

3

less

It follows that the climate is warmer/colder (choose one) today than formerly.

4

warmer

There have been four very cold periods, called Ice Ages, in the last 1 million years. The name given to one of these cold climatic periods is an _____.

5

Ice Age

Panel 5.1 shows that, during the Ice Age, much of both North America and Europe were covered with a massive _____.

6

ice sheet

At this time, the ice sheet covered Britain north of a line connecting the towns of Bristol and London. All the lowlands in Britain, north of this line, have been affected by the _____.

ice

The ice sheet carried loose pieces of rock in and on the ice,
This loose material is called _____.

moraine

When the ice melted, this moraine was deposited. In fact the
main work of the ice, in a lowland area, is to _____ this
material.

deposit

Thus, when the ice melted, much of lowland Britain was covered
with glacial _____.

deposits or moraine

Although in some lowland areas the ice eroded the surface,
leaving behind a lake strewn countryside, as in Finland and
the Canadian Shield, in most _____ areas show the effects
of glacial deposition.

lowland

We are now going to learn about the landforms which were
caused by glacial deposition. Boulder clay, drumlins, erratics
and eskers were formed in this way. How many features are
listed here for us to study?

4

The ice sheets were often hundreds, sometimes thousands of feet
thick. They carried vast accumulations of clay with rock-fragments
fragments. When the ice melted, this material, which is called
boulder clay, was left behind. Boulder clay consists of _____
with



IRISH
REPUBLIC

PANEL 5.3

Frame	Answer	VOVX	Frame	Answer	VOVX
1			22		
2			23		
3			24		
4			25		
5			26		
6			27		
7			28		
8			29		
9			30		
10					
11					
12			31		
13					
14					
15					
16			32		
17					
18					
19			33		
20					

TIME _____

TEST 5

1

2

3

4 { (i)
(ii)
(iii)

5 { (i)
(ii)

6 {

PANEL 5.1

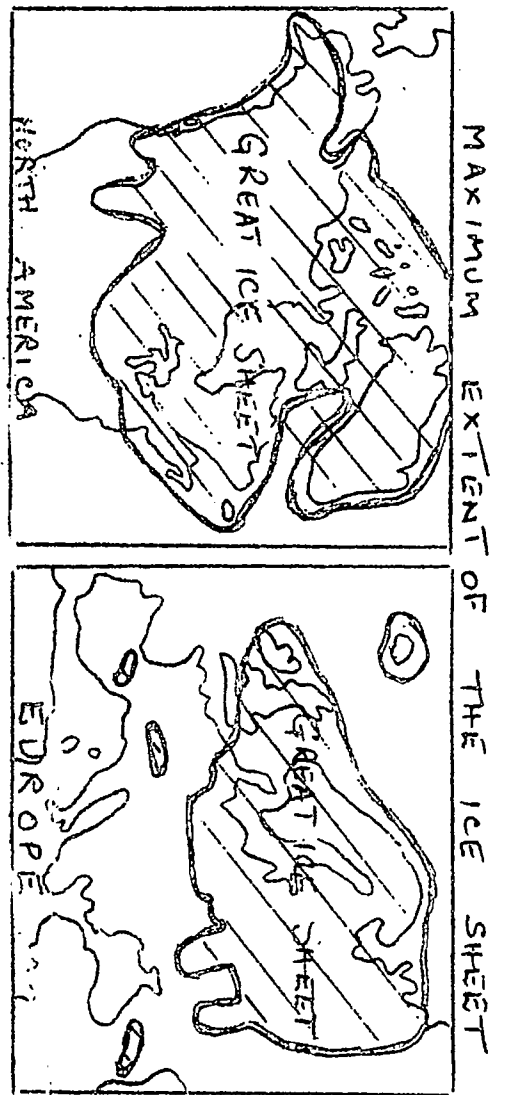

PANEL 5.2

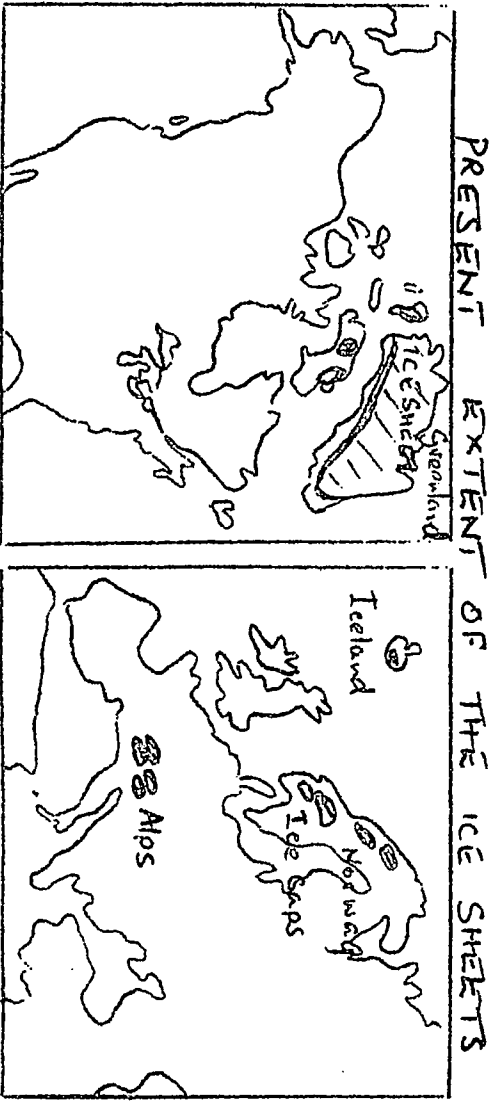

13

clay with rock fragments

The boulder clay covered hills and filled valleys. In East Anglia it is over 300 feet thick. Boulder clay is over 300ft thick in _____.

14

East Anglia

Boulder clay often makes a fertile soil. East Anglia is an important farming area because the soil is _____.

15

fertile

So much of lowland Britain is covered with a layer of _____ which was deposited when the ice melted. This rock is made of _____ with _____.

16

boulder clay; clay with rock fragments

In some areas small mounds of moraine formed beneath the moving ice. When the ice melted they were left behind or _____.

17

deposited

These small mounds of moraine are called drumlins. Drumlins are made of _____.

18

moraine

This is a section of a drumlin. The diagram shows that a drumlin can be as high as _____ and as long as _____.

← up to 1 mile →

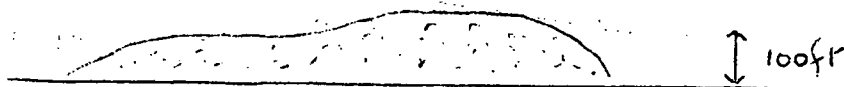

32

19

100ft; 1 mile

Drumlins are _____ rounded hills made of _____.

20

small; moraine

The small rounded hills and islands in Panel 5.3 are _____.

In which part of Northern Ireland was the photograph taken?

21

drumlins; Co:Down

Boulder clay is present in _____ and drumlins can be found in _____, Northern Ireland.

22

East Anglia; Co:Down

Individual large boulders were carried on the ice for many miles and were left behind when the ice melted. They are called erratics. An erratic is a _____.

23

large boulder

This erratic is resting on the _____.

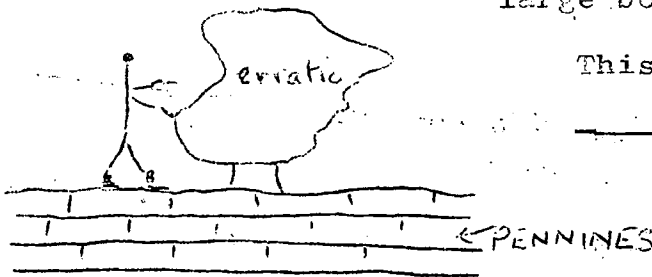

24

Pennines

The erratic in the diagram in the last frame is one of many resting on the hillside, near Austwick, in the Pennines. Erratics are common in the _____ district of the Pennines.

25

Austwick

The large boulder, shown in frame 23, was left behind by the _____.

26

erratic

As the ice sheet melted, rivers of meltwater flowed out from under the edge of the ice sheet. These rivers resorted the moraine before depositing it in the form of low ridges of sand and gravel, called eskers. The low ridges are made of _____ and _____. This material was rearranged by the _____.

27

sand and gravel; meltwater (rivers)

These low ridges are called _____.

28

eskers

Eskers are _____ which were deposited by the _____.

29

low ridges; meltwater or rivers.

Eskers are very useful in populated areas because _____ and _____ is used to make cement.

30

sand and gravel

There are many eskers, winding across a lake filled countryside, in Sweden. Eskers are widespread in _____.

31

Sweden

Name the 4 glacial features, we have studied, which can be found in lowland areas.

32

boulder clay; drumlins; erratics; eskers (in any order)

Boulder clay is made of _____ with _____; it can be found in _____. Drumlins are _____ hills made of _____; they can be seen in _____.

33 clay with rock fragments; East Anglia; small; moraine; Co:Down

An erratic is a _____ and an esker a _____
 made of _____ and _____. Erratics are present near _____
 in the _____ and eskers in _____.

large boulders; low ridge; sand and gravel; Austwick in the PP
 Pennines; Sweden

You have now completed the learning programme.

Answer the questions in Test 5 on page 35.

TEST 2

1 { _____

2 { (a) _____
b) (i) _____
(ii) _____
c) _____

3 { _____

4 _____

5 _____

6 _____

NAME

SECTION 2

TIME

Frame	Answer	✓orX	Frame	Answer	✓orX
1			18		
2			19		
3	a)		20		
	b)				
	c)				
4			21		
5			22		
6					
7	A		23		
	B				
8			24		
9					
10			25		
11			26		
12			27	A	
				B	
13			28		
14			29		
15			30		
16			31		
17			32		

TIME

- 1 High in the mountains snow accumulates to a great depth in the snowfield. This snow changes to ice because of the pressure of the snow above. The ice then flows down the mountain side in valleys. These 'rivers' of ice are called _____.

2

glaciers

The river Rhine flows from the snowfields in the Alps. The river _____ starts as a glacier.

3

Rhine

The movement of the ice in a glacier can be measured by fixing a row of stakes across the glacier, as in diagram 1. The second diagram shows the position of the same stakes some days later.



- a) Draw an arrow to show the direction the ice is moving in. Which part of the glacier is moving b) fastest? c) slowest?

4

- a) b) centre c) sides

The friction caused by the ice rubbing against the solid rock of the valley sides slows the movement of the ice. The ice moves more slowly at the sides of the glacier because of _____.

5

friction

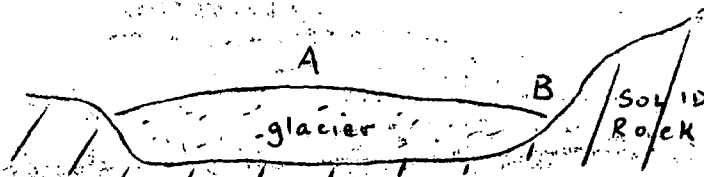

This is a section across the glacier. Which letter on the diagram indicates the slowest moving ice?

6

B

The glacier moves down the valley until the temperature is warm enough to melt the ice. Then the meltwater will flow as a _____.

7

river

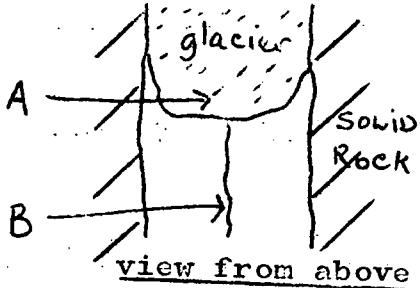

The end of the glacier is called the snout. In ^{the} diagram A is the _____. B shows the icy water which flows from the end of the glacier; it is a _____.

8

A snout; B river

The ice, in the glacier, may crack as it moves down the slope.

Large cracks or gashes in the ice are called crevasses. In this diagram a number of _____ are shown.

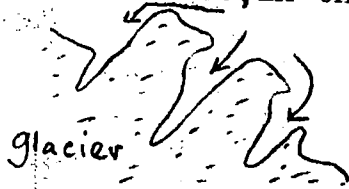

Section of glacier surface

9

crevasses

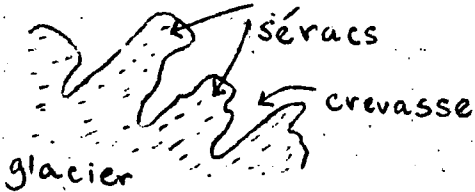

This diagram shows that the pinnacles of ice remaining between the crevasses are called _____.

10

seracs

Crevasses may form if the valley widens. The crevasses in this diagram formed because the valley _____.

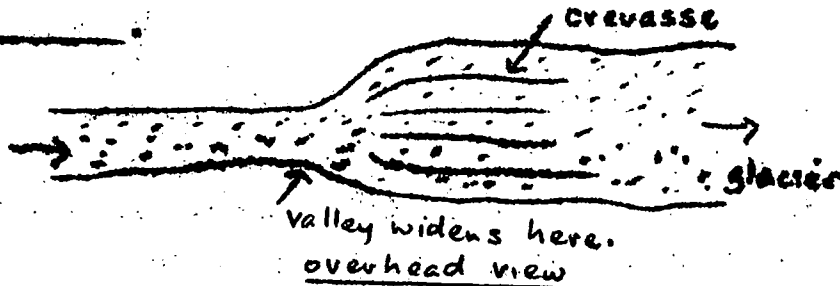

11

widened

Crevasses also form if the valley floor suddenly steepens. Copy this diagram and mark, with an X, the point where there is a marked change in slope of the valley floor.

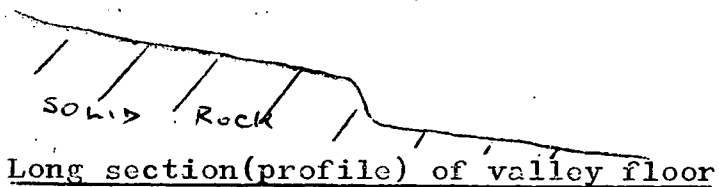

12

This diagram shows the ice cracked at point Y. These cracks or _____ at point Y were caused when the valley floor _____.

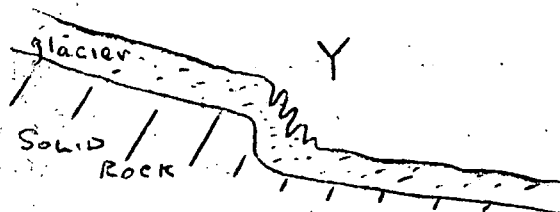

13

crevasses; steepened

This is an enlargement of point Y in the last frame. The large cracks in the ice are _____. The pinnacles of ice remaining between them are _____.



14

crevasses; seracs

Crevasses will form when 1) the valley _____ or 2) the valley floor _____.

15

widens; steepens

In Panel 1.2 point X indicates a number of _____.

16

crevasses

If the glacier moves over a very steep fall in the valley floor, the ice breaks up into a chaotic pattern of crevasses, called an icefall. Points X and Y in the photograph are _____.

17

icefalls

Changes in temperature cause many pieces of rock to splinter off the mountain peaks and fall onto the ice. This loose rock material is called moraine. Moraine is _____ which has fallen from the _____ onto the _____.

18

Loose rock(material); mountain peaks; ice

In the photograph 1 and 2 both show _____.

19

moraine

If the loose rock is carried at the sides of the glacier, it is called a lateral moraine. On the photograph 1 is a _____.

20

lateral moraine

If two glaciers meet and join, two of the lateral moraines will be carried down the centre of the glacier as a medial moraine.

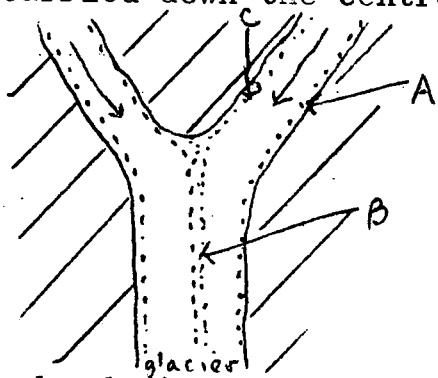

overhead view

In this diagram A and C are at the sides of the glacier; they are _____.

B is in the centre of the glacier and is a _____.

21

lateral moraine; medial moraine

In the photograph, 1 is a _____ moraine, 2 a _____.

22 lateral; medial moraine

The glacier carries the moraine to its end or snout. As the ice melts the moraine is deposited (dropped) across the valley. At the end of the glacier we expect to find _____ deposited _____ the valley.

23

moraine; across

This moraine is the terminal (end) moraine. In the diagram

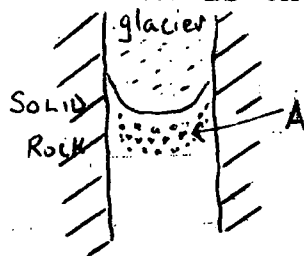

A shows a moraine across the valley. It is a _____ .

24

terminal moraine

A medial moraine is present at the _____, a lateral moraine at the _____ and a terminal moraine at the _____ of a glacier.

25

centre; side; end

The end of the glacier is not always in the same position in the valley. If the temperature becomes colder over a long period of time, the ice will not melt so readily and the end of the glacier will move _____ the valley.

26

down

Slowly a _____ moraine will form across the valley.

14
27

terminal

If now the temperature becomes warmer, over a long period of time, the ice will melt more easily

and the snout will move up the valley. In the diagram A is the

_____ and B the _____.

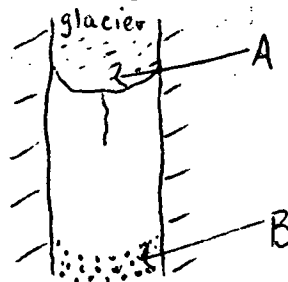

28

A snout; B terminal moraine

Icy cold water will flow from the end of the glacier to form a stream, labelled _____ in the diagram.

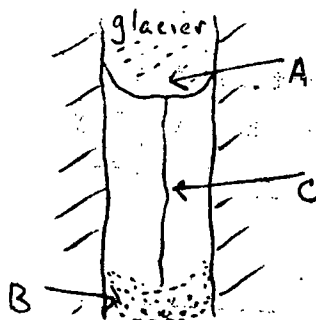

29

C

The terminal moraine may now dam the river, preventing some of the meltwater from flowing downstream. Thus a _____ will form.

30

lake

Copy this diagram and fill in a lake which has been dammed behind the moraine. Label the lake a moraine-dammed lake.

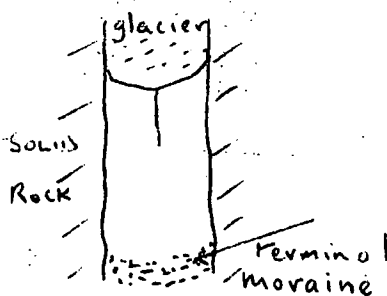

31

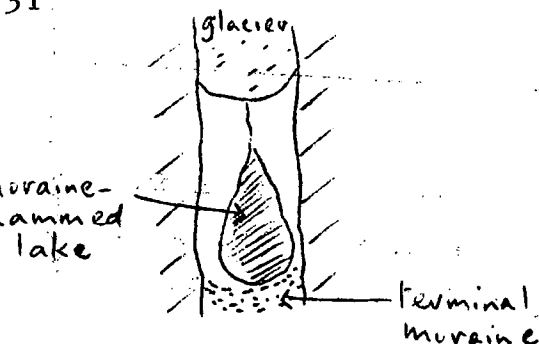

The biggest lake in the Lake District was formed in this way. What is it called?

(Use your atlas page 24 if necessary).

In the Lake District, Lake _____ was formed because a _____ moraine prevented some of the meltwater from escaping to the sea.

Windermere; terminal

This is the end of Section 2.

Now answer Test 2 on page 16.

TEST 2

Answer all questions. Answers to be written on the back of your Section 2 answer sheet.

- 1 The ice within a glacier does not move at the same speed. The ice near the _____ moves slowest because _____.
- 2 a) Sometimes large cracks, called _____, form on the surface of the ice. b) These cracks may be caused by i) _____
ii) _____.
- 3--The-leeese-reek
 - c) The pinnacles of ice, between the cracks, are _____.
- 3 The loose rock, which falls onto the glacier from the mountain peaks, is called _____. When it is carried along the sides of the glacier it is a _____.
- 4 Name a river which starts as a glacier.
- 5 Draw a clear diagram to show how a moraine-dammed lake is formed. Label your diagram.
- 6 Give an example of a moraine-dammed lake.

SECTION 4 Glacial Features on an O.S. map

21 frames

Use the ~~O.S.~~ Ordnance Survey map (Panel 4.1) for this section.

1 On the map, brown contour lines are used to show the height of the land. How high is the labelled contour in grid square 1416?

2 1,600ft

Contours are drawn close together to show a steep slope and far apart when the slope is gentle. West of Buttermere village, in grid square 1716 the slope is _____ and in grid square 1614 the slope is _____.

3 gentle; steep

When the slope is very steep another symbol, representing a cliff, is used on O.S. maps. Cliffs are shown by short black lines. A very steep slope is shown in this way at _____ in grid square 1819.

4 Vanlope

When the slope is so steep that it is almost vertical, the symbol used on an O.S. map to represent it is the _____ symbol.

5 cliff

This map shows part of the Lake District. On it we should be able to find examples of corries, arêtes, U-shaped valleys with their hanging valleys, waterfalls and ribbon lakes. First we will look for corries and arêtes. Will we find them near the mountain peaks or in the main valleys?

6

near the mountain peaks

A corrie is circular or rounded in shape and has a very steep backwall. It may contain a small lake or tarn. Now what will the corrie look like on a contour map? The contour lines will make a rounded pattern. The walls are steep, so the contour lines will be drawn _____. If the walls are very steep a _____ may be indicated.

7

close together; cliff

Now draw a contour map of a corrie in this way. First draw a small tarn with a stream flowing from it. Around this draw 4 contour lines in a pattern which shows the rounded arm-chair shape. Remember that the sides of the corrie are very steep and the base flat. Label the lowest contour 1,000ft.

8



Look at the area called Ling Comb in square 1515. This is a corrie. It is near the mountain peak called _____ and overlooks the _____ Water valley.

9

Red Pike; Crummock

Now you can find a named example of a) a corrie with a tarn, b) a corrie.

10

a) Bleaberry b) Burtness Combe

Arêtes are very steep mountain ridges backing the corries. The cliff symbol is used to show these craggy mountain ridges. Find 2 named examples from the map.

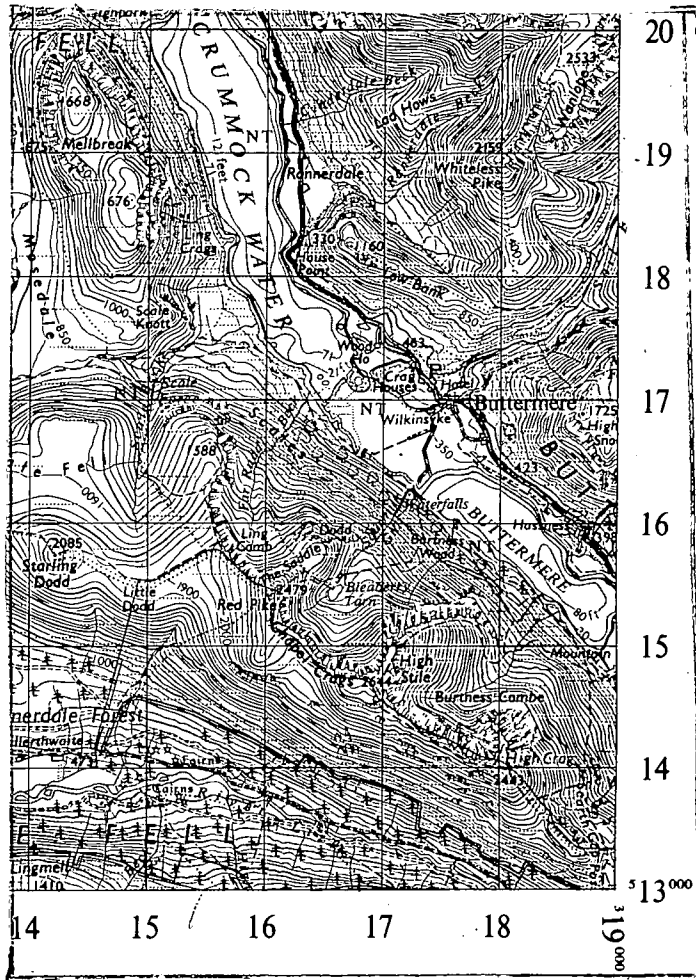

Scale: One Inch to One Statute Mile = $\frac{1}{63360}$

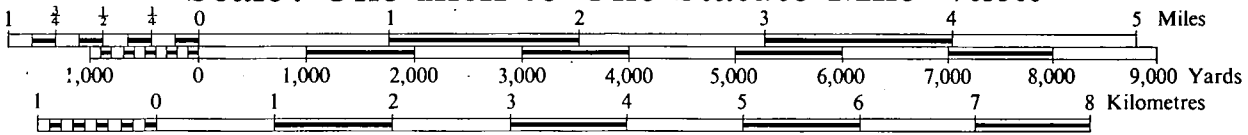

Heights are in feet above Mean Sea Level. Contours are at 50ft. intervals

Any 2 from High Crag; High Stile; Chapel Crag; The Saddle; Ling Comb.

The main valleys in a glaciated highland area are U-shaped. They have steep sides and a flat base. The steep sides are shown on the map by contour lines drawn _____, the flat base by contour lines drawn _____.

close together; far apart

On this map only one large U-shaped valley is shown. Name it.

Crummock Water (Buttermere) valley

How wide is the valley bottom (below 350ft) near the village of Buttermere? Give your answer in parts of a mile. The scale of the map is 1 inch to 1 mile.

1/3 ml. or ~~500~~⁶⁰⁰ yards or 3 furlongs approx.

Part of the flat valley bottom may contain a long thin ribbon lake. Name the 2 ribbon lakes shown on this map.

Crummock Water; Buttermere

Now count the small tributary streams which flow into the Buttermere-Crummock Water valley from the west.

7

We wish to find if any or all of these tributary valleys are hanging valleys. This is a contour map of a river valley. Notice the contours make a V-shape, with the apex (point) of the V pointing towards the highland. The river on this map begins at a height of just over _____ ft.



27

17

400ft

When the contours are evenly spaced the river bed has an even slope or gradient. Has the river in frame 16 an even gradient?

18

yes

A hanging valley does not have an even slope for its full length. At the point where it enters the main valley the slope is steeper than near the source (beginning) of the stream. Where the slope is steeper the contours will be drawn closer together/wider apart (choose one).

19

closer together

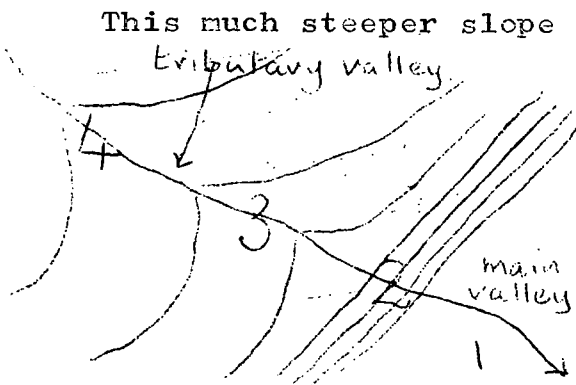

This much steeper slope is shown on a contour map by contours which cut straight across the river, at the point where the valley is hanging. This contour map shows a hanging valley. At which point (1, 2, 3 or 4) does the tributary valley 'hang' over the main valley?

20

2

Now look at the stream flowing into Buttermere from Burtness Combe. Towards the corrie the contours are V-shaped, but near the lake they cut straight across the stream showing that this is a 'hanging' valley. Name 2 more examples of hanging valleys entering the main valley from the west.

21

2 from Scale Beck; Far Ruddy Beck; Sour Milk Gill

Look closely at the map and find a waterfall along one of the streams entering the lakes from the west.

Scale Force or along Sour Milk Gill

This section is now complete.

Now answer Test 4 set out below.

TEST 4

answer sheet.

Answers to be written on the back of the Section 4

Use the O.S. map of part of the Snowdon District for this test. The map is on page 53 or 58 in Margaret Wood - Map Reading for Schools.

Find evidence, from the map, which suggests that this area in Wales has been glaciated, by giving one named example of each of the following features: arête, corrie, U-shaped valley, hanging valley, ribbon lake. State clearly which is which.

SECTION 3 Glacial Features in Mountainous Areas

30 frames

1 Panel 3.1 shows that Britain was covered by ice north of a line connecting the towns of _____ and _____.

2
Bristol and London

This means that most of _____ has been affected by ice.

3
Britain

Using Panel 3.1, name a highland area in Britain where we can study the effects of ice.

4
Any one from Welsh Uplands, Lake District, Grampians, N.W. Highlands

During the Ice Age, the main work of the ice, in these areas, was to wear away or erode the surface. The rocks were _____ by the ice.

5
eroded

High up on the mountainside snow and ice accumulated in hollows called _____.

6
corries

A corrie is ~~an~~ arm-chair shaped; that is it is circular with very steep walls and a flat base. The sides of the corrie are _____ and the bottom _____.

7

very steep; flat

All corries are this shape because of the way they were formed.

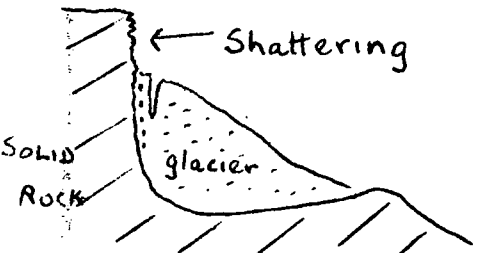

Section of a corrie

The walls are very steep and rugged because changes in temperature (freeze-thaw process) caused pieces of rock to shatter and fall off. The diagram shows that the backwall is very steep and rugged because of _____.

8

shattering

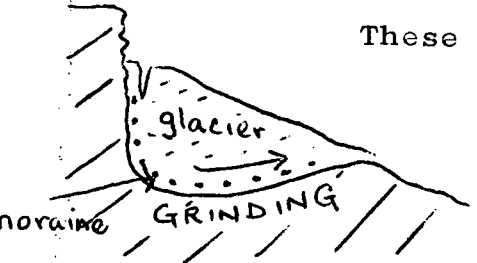

These fragments fell into the ice in the corrie. They helped the ice to grind away and erode the base of the corrie. The slope here is much gentler (flatter) because of the _____ action.

9

grinding

The feature shown in this diagram is a _____. Name the process of erosion which resulted in the slope at 1 and 2.

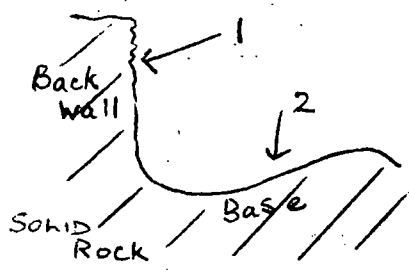

10

corrie; 1 shattering; 2 grinding (ice action)

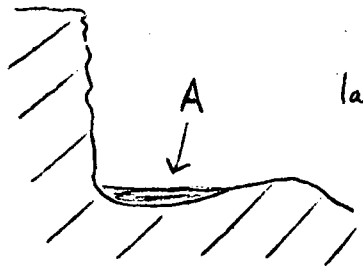

In some of the corries a small lake or tarn remained when the ice melted. In the diagram A is a _____.

MAXIMUM EXTENT OF ICE SHEET IN BRITAIN

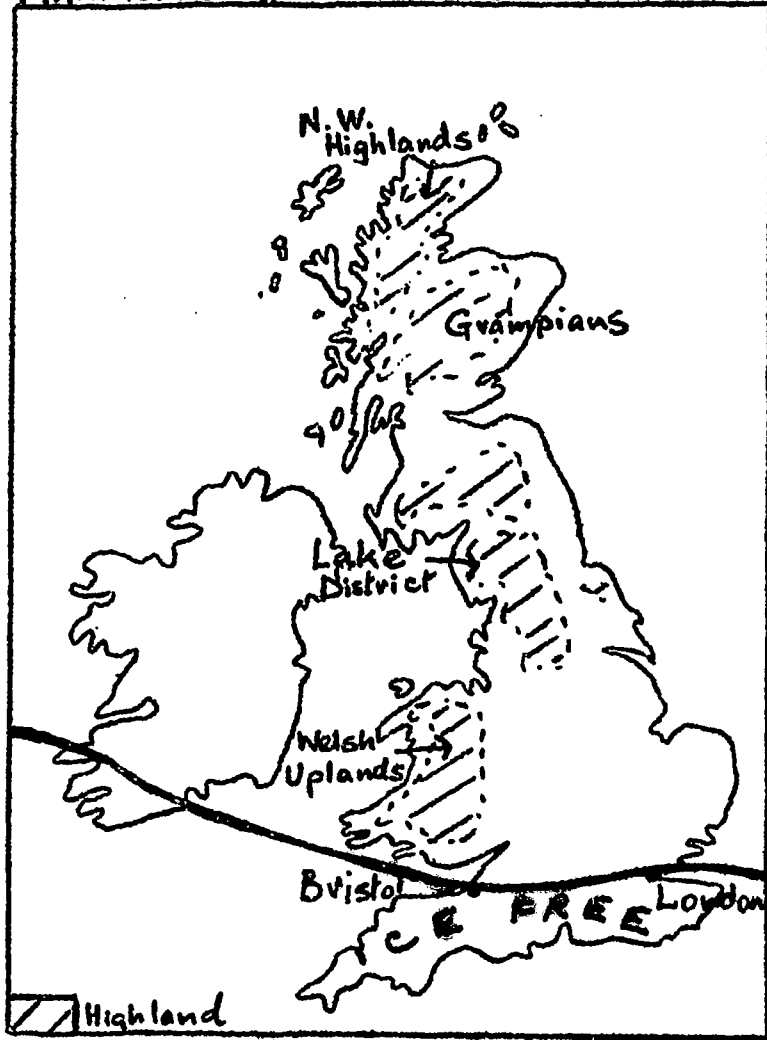

PANEL 3.3

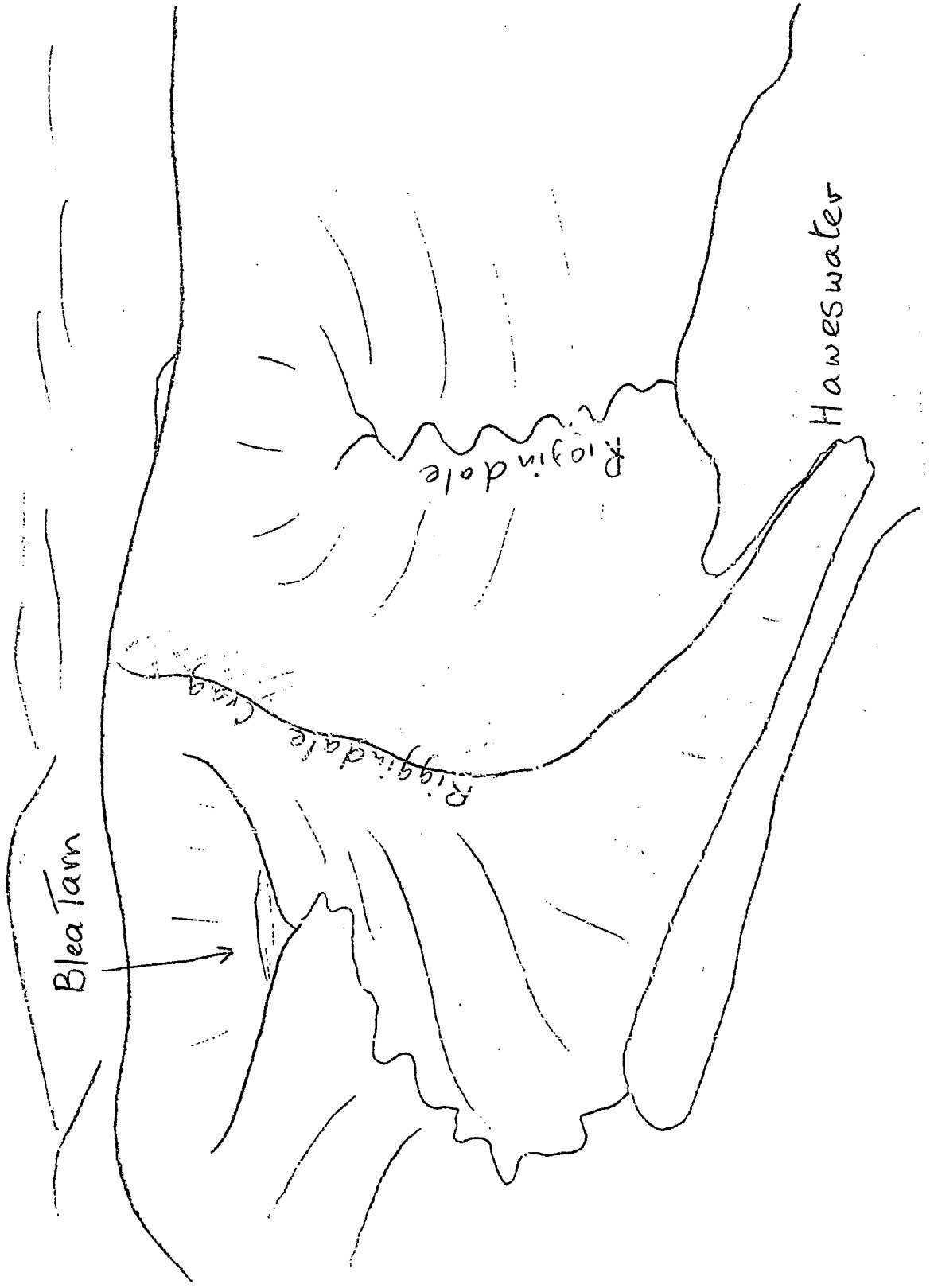

Name _____

SECTION 4

TIME _____

Frame	ANSWER	✓ OR X	Frame	ANSWER	✓ OR X
1			15		
2			16		
			17		
3			18		
4			19		
5			20		
6				21	
7					
8					
9	(a)				
	(b)				
10					
11					
12					
13					
14					

TIME _____

PANEL 3.2



TEST 3

a) (i)

(ii)

(iii)

b)

c)

a) (i)

(ii)

b) 1

2

3

c) (i)

(ii)

SECTION 3 NAME _____

TIME _____

NO	ANSWER	✓ SIX FINGER	ANSWER	✓ SIX
1				
2			14	
3				
4			20	
5			21	
6			22	
7			23	
8			24	
9				
10			25	
11				
			26	
			27	
			28	
12				
13			29	
14				
15				
16			30	
17				
18				

TIME _____

11

tarn

A corrie is _____ in shape, with a _____ sides and _____ base. It may contain a _____.

12

circular; very steep; flat; tarn

Panel 3.2 is a photograph taken in the Lake District. The feature at 1 is a _____. Panel 3.3 is a field sketch of the area. Use it to find the actual name of 1.

13

corrie; Blea Tarn

When two corries or valley heads erode backwards into the

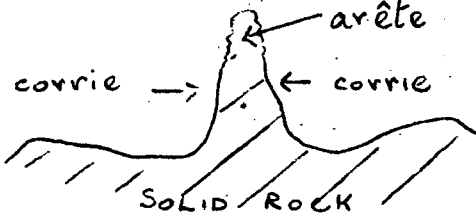

mountain a razor-edged ridge results, called an _____ (see diagram). The slopes of the ridge are _____.

14

arête; very steep

On the photograph 2 is an _____. Panel 3.3 shows that its name is _____.

15

arête; Riggindale Crag

Corries and arêtes are found near the top/on the side/at the foot (choose one) of the mountain.

16

near the top

The moraine, which is frozen in the sides and base of the valley glacier, converts it into a giant rasp. The glacier moves slowly, rubbing against the valley sides. Here also the main work of the ice is to _____ the surface,

17

erode

A normal river valley is V-shaped in cross section. One through which a glacier passed is U-shaped. Diagram 1 and 2 are cross sections of two valleys. Which one has been glaciated?

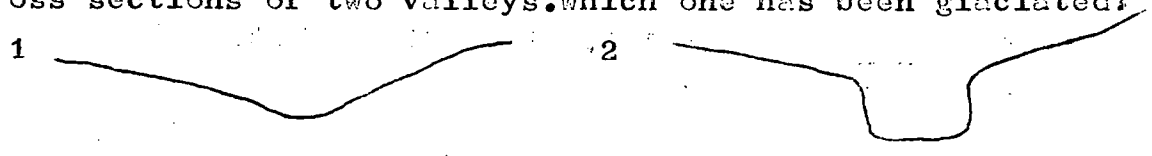

18

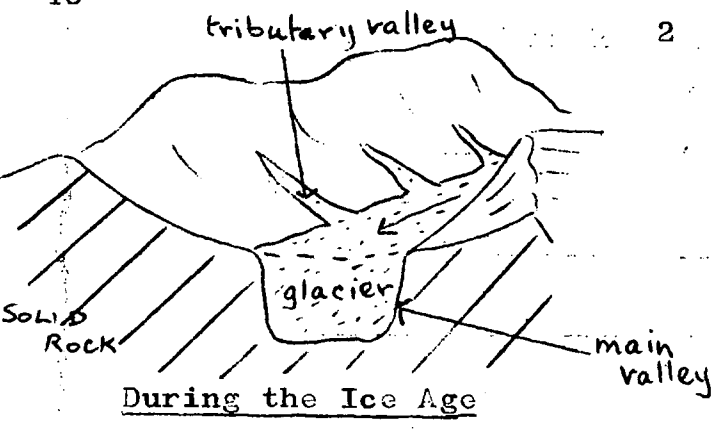

When a glacier passes down a valley, it changes from V-shaped to _____.

19

U-shaped

The sides of a U-shaped valley become very _____ and the valley bottom w _____ and f _____.

20

steep; wide and flat

In the photograph, the feature marked 3 is a _____ valley. Panel 3.3 shows that its name is _____.

21

U-shaped; Riggsdale

The glaciers in the tributary valleys were bigger/as big/smaller (choose one) than in the main valley. (Use the diagram in frame 18 if necessary.)

Because they were smaller, the valleys which they cut were bigger/smaller (choose one) than the main valley.

23

smaller

When the ice melted, the small tributary valleys were left 'hanging' above the main valley. They are called hanging valleys. In the diagram A is a _____ valley, B a _____ valley.

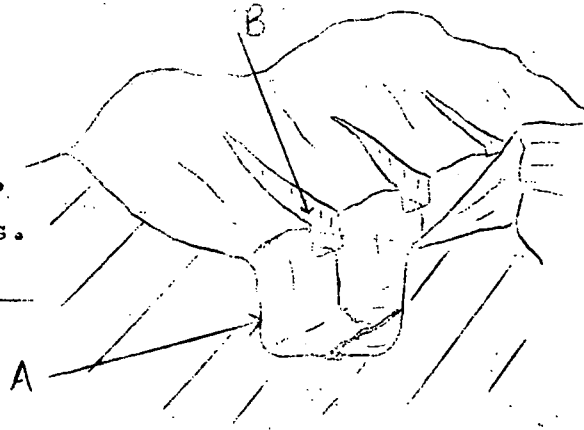

24

U-shaped; hanging

If the edge of the main valley is extremely steep the tributary streams will fall into it as _____.

25

waterfalls

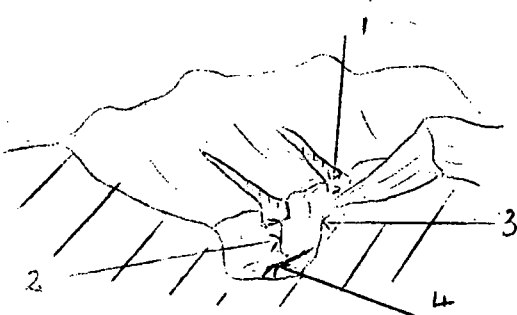

In this diagram a U-shaped valley, hanging valley, waterfall and river are indicated. Identify them.

26

1 hanging valley; 2 waterfall; 3 U-shaped valley; 4 river

In the bottom of some of the U-shaped valleys large areas of water were left behind after the ice had melted. Large bodies of water surrounded by land are called _____.

27

lakes

These lakes are called ribbon or finger lakes because they are long and thin. A ribbon lake is a _____ lake found in the _____ of a U-shaped valley.

28

long thin;bottom

The ribbon lake filling in part of Riggindale (Panel 3.3) is called _____.

29

Haweswater

Next we will look at the photograph to see what we have learned about it. This photograph was taken in the _____.

The features shown on it, which were eroded by the ice, are

1 a _____, 2 an _____, and 3 a _____.

In the foreground is a _____.

30

Lake District; 1 corrie; 2 arête; 3 U-shaped valley; ribbon lake

The actual names of the four features in this part of the

Lake District are 1 _____, 2 _____,

3 _____ and _____.

Blea Tarn; Riggindale Crag; Riggindale; Haweswater

You have now finished Section 3.

Answer the questions in Test 3 on page 23.

TEST 3

Answer all questions.

Answers to be written on the back of your Section 3 answer/sheet.

- 1 Name a highland area in Britain which has been glaciated.
- 2 The main work of the ice, in a highland area, is to _____ the surface.
- 3 a) (i) Describe a corrie.
(ii) Draw a labelled diagram to show how it was formed.
(iii) Give one example.
- b) What is an arête?
- c) Where are corries and arêtes found in these highland areas?
- 4 a) (i) What is the main valley in a glaciated highland area called?
(ii) How does it differ in shape from a normal river valley?
- b) Label the three features indicated on this diagram.

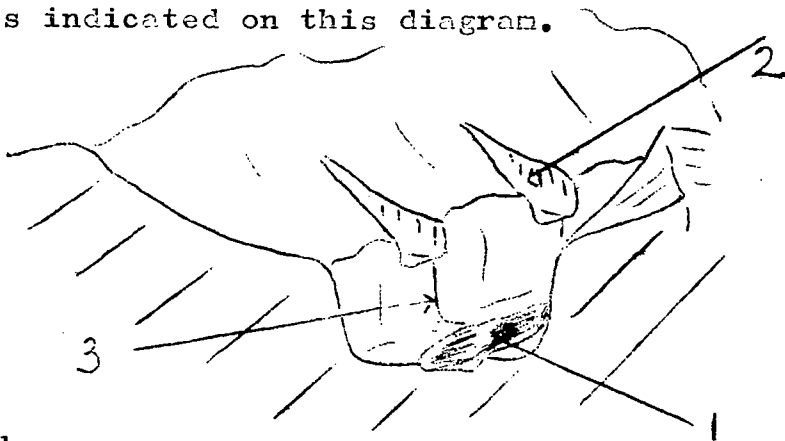

- c) (i) Describe a ribbon lake.
(ii) Give one example.