

## Durham E-Theses

---

### *The cartography of time-changing phenomena: the animated map*

Helen M. Mounsey

#### How to cite:

---

Mounsey, Helen M. (1982) The cartography of time-changing phenomena: the animated map. Doctoral thesis, Durham University.

#### Use policy

---

The full-text may be used and/or reproduced, and given to third parties in any format or medium, without prior permission or charge, for personal research or study, educational, or not-for-profit purposes provided that:

- a full bibliographic reference is made to the original source
- a <https://etheses.durham.ac.uk/id/eprint/10276/> is made to the metadata record in Durham E-Theses
- the full-text is not changed in any way

The full-text must not be sold in any format or medium without the formal permission of the copyright holders.

Please consult the [full Durham E-Theses policy](#) for further details.

ABSTRACT.

The cartography of time-changing phenomena: the animated map.

Helen M Mounsey.

Thesis presented for degree of Doctor of Philosophy, Department of Geography, University of Durham.  
February, 1982.

This research examines the role of the animated film in the portrayal of time series data, specifically change in the British population. It concentrates on cartographic animation and first reviews techniques developed thus far for computer-animated generation of maps for films.

In order to generate an animated film, time series data is first needed. Existing sources of time series data are shown to contain serious deficiencies for this purpose, and thus a new set of population data is generated for Britain throughout the period 1901 - 1971, and based on the Census.

Ways of presenting change in this data set are then examined. Conventional methods of measuring change in the population, whilst satisfactory in static cartography, have definite limitations when used in animated cartography. Two methods, based on population density and on expected change in the population, are developed and the results mapped. As with conventional methods of measuring change, standard cartographic techniques may not be used in animated filming with any degree of success, and the resultant film shows significant departures from accepted cartographic theory.

The method of film production is then examined, from the compilation of the maps themselves, through the use of the microfilm plotter in generation of the film, to the final soundtracking. The resultant film is enclosed with the thesis; the final chapter examines the success of this film. Whilst significant imperfections are shown in this example, it is concluded that the animated film has a role to play in the portrayal of time series data.

**THE CARTOGRAPHY OF TIME-CHANGING PHENOMENA: THE ANIMATED MAP**

**Helen M Mounsey**

**Thesis presented for degree of Doctor of Philosophy.  
Department of Geography, University of Durham.  
February, 1982.**



The copyright of this thesis rests with the author.  
No quotation from it should be published without  
his prior written consent and information derived  
from it should be acknowledged.

22. MAY 1984

CONTENTS

1	AN INTRODUCTION . . . . .	1
2	THE TECHNIQUE AND USES OF ANIMATION . . . . .	8
2.1	Principles of animation . . . . .	8
2.2	The use of animation in cartography . . . . .	9
2.3	The development of computer-aided animation. . . . .	10
2.4	Some computer-animated films examined . . . . .	17
2.4.1	The work of Moellering, Ohio State University	23
2.4.2	The work of Dutton, Harvard University . . . . .	29
2.4.3	The work of Massey, University of Melbourne . . . . .	32
3	SOURCES OF TIME SERIES DATA . . . . .	37
3.1	Data requirements . . . . .	38
3.2	Sources of time series data . . . . .	46
3.2.1	Survey v. archive data . . . . .	48
3.2.2	Archival data . . . . .	49
3.2.3	Areal archives . . . . .	50
3.2.4	Non-areal archives . . . . .	56
3.3	Problems of time series data collection . . . . .	62
3.3.1	Spatial attributes . . . . .	63
3.3.2	Temporal attributes . . . . .	74
3.3.3	Thematic attributes . . . . .	76

3.4	Sources of time series population data . . . . .	79
3.4.1	The Census of Population . . . . .	80
3.4.2	The mid-year estimates . . . . .	82
3.4.3	The Electoral Register . . . . .	83
3.4.4	Public utility and other official lists . . . . .	86
4	THE CREATION OF A POPULATION TIME SERIES DATA SET . . . . .	88
4.1	The census of population . . . . .	88
4.1.1	Development of local government areas in England and Wales . . . . .	89
4.1.2	Development of local government areas in Scotland . . . . .	104
4.2	The mid-year estimates . . . . .	111
4.2.1	Calculation of the mid-year estimates . . . . .	111
4.2.2	Accuracy of the mid-year estimates . . . . .	117
4.2.3	The mid-year estimates for Scotland . . . . .	119
4.2.4	Problems associated with the use of the mid-year estimates . . . . .	120
4.3	Derivation of a census-based population data set . . . . .	122
4.3.1	Encoding population for England and Wales . . . . .	127
4.3.2	Encoding population for Scotland . . . . .	135
4.3.3	The formation of post-1974 areas, England and Wales . . . . .	137
4.3.4	The formation of post-1975 areas, Scotland . . . . .	139

5	VALIDATION OF THE DATA SET . . . . .	142
5.1	Error checking: the first stage . . . . .	142
5.2	A survey of planning officers . . . . .	167
5.3	Error checking: the second stage . . . . .	176
5.4	Preparation of data . . . . .	186
5.5	Topographic data . . . . .	193
6	MAP DESIGN STRATEGIES . . . . .	199
6.1	What type of map? . . . . .	200
6.1.1	Choropleth mapping . . . . .	216
6.2	Measures of population change . . . . .	221
6.2.1	The representation of implied change . . . . .	222
6.2.2	The representation of measured change . . . . .	244
6.3	Map design . . . . .	254
6.3.1	Map design in practice . . . . .	261
7	FILM PRODUCTION . . . . .	266
7.1	Facilities at NUMAC . . . . .	268
7.1.1	Hardware . . . . .	268
7.1.2	Software . . . . .	269
7.2	Facilities at the Rutherford Laboratory . . . . .	276
7.2.1	Hardware . . . . .	276
7.2.2	Software . . . . .	279
7.3	Film tests . . . . .	283
7.3.1	General layout . . . . .	285
7.3.2	Symbolism . . . . .	291

7.3.3	Timing of films . . . . .	297
7.4	Film production . . . . .	300
8	AN ANALYSIS OF THE RESULTS . . . . .	305
8.1	The animated film in population mapping . . . . .	305
8.1.1	Overall characteristics . . . . .	306
8.1.2	The density section . . . . .	310
8.1.3	The chi section . . . . .	311
8.2	The animated film as a cartographic technique . . .	315

LIST OF TABLES

TABLE NUMBER	PAGE
3.1	Some official sources of time series data . . . . . 61
4.1	Boundary changes in England and Wales . . . . . 94 - 95
4.2	Population of pre-1974 local government areas in England and Wales . . . 100
4.3	Population of post-1974 local government areas in England and Wales . . 103
4.4	Boundary changes in Scotland . . . . . 107
4.5	Population of pre-1975 local government areas in Scotland . . . 109
4.6	Change in population of selected areas, 1971-1979 . . 122
4.7	Population of selected areas, 1921-1961 . . . . . 132
5.1	Errors . . . . . 144
5.2	Population of selected New Towns, 1901-1971 . . . . . 153
5.3	Census dates, 1901-1971 . . . . . 161
5.4	Population of selected holiday resorts, 1901-39 . . . 161
5.5	Population of selected county districts, 1901-51 . . . 166
5.6	Descriptive statistics, polygons . . . . . 196
5.7	Descriptive statistics, segments and boundary sections 198
6.1	Application of the chi-square measure . . . . . 253

6.2	Application of the signed chi-square measure . . . . .	253
7.1	Results of film trials . . . . .	296
8.1	Comparison of mid-year estimates and the interpolated data set	307

LIST OF FIGURES

FIGURE NUMBER	PAGE
1.1	Classes of real and virtual maps . . . . . 4
2.1	A typology of graphic displays . . . . . 18
3.1	The data collection process . . . . . 39
3.2	Geographical data sources . . . . . 47
3.3	Population density, 1981 . . . . . 67 - 69
4.1	Development of local government areas in England and Wales . . . . . 91
4.2	Development of local government areas in Scotland . . . . . 105
4.3	Types of boundary change . . . . . 124
4.4	To illustrate the method of calculation . . . . . 129 - 130
5.1	Population of Tyne and Wear, and Avon, 1901-1971 . . . . . 163
5.2	Population of selected London Boroughs, 1901-1971 . . . . . 164
5.3	Example printout for survey of Planning Officers . . . . . 169
5.4	Response from survey of Planning Officers . . . . . 171
5.5	Interpolated population for Harlow . . . . . 190
6.1	To illustrate the use of proportional symbols . . . . . 205 - 207
6.2	To illustrate the use of dot mapping . . . . . 210 - 212
6.3	Population density, 1971 . . . . . 226 - 227
6.4	Population density around a city centre . . . . . 233

6.5	Changes in population density, 1901-1971 . . . . .	237 - 239
6.6	Rank ordered population densities, 1901-1971 . . . . .	241
6.7	Population growth curves . . . . .	247
6.8	Comic and cine mode . . . . .	264
7.1	The film production process . . . . .	282
7.2	Sample frames from film . . . . .	289 - 290
7.3	Example GIMMS run . . . . .	301
8.1	Difference between the mid-year estimates and the interpolated data set . .	309

DECLARATION

I declare that the contents of this thesis have not previously been submitted at this or at any other University.

*Helen M. Mounsey.*

Helen Mounsey.

Department of Geography,

University of Durham.

February, 1982.

STATEMENT OF COPYRIGHT

The copyright of this thesis rests with the author. Information derived from it should be acknowledged and no part of the work published without her prior written consent.

PREFACE

"I'm only just beginning to realize" said George "what a wonderful invention the map is. Geography would be incomprehensible without maps. They've reduced a tremendous muddle of facts into something you can read at a glance. Now I suspect economics is fundamentally more difficult than geography. Except that it's about things in motion. If only someone could invent a dynamic map..." (1)

The aim of this thesis is not to invent the dynamic map: that was in fact done in 1935, long before C P Snow wrote the above passage. Rather, it aims to illustrate the use of the dynamic map in reducing the complexities within a data set to something that may be read at a glance. More specifically, it describes research done into the use of the animated map in portraying change in the British population throughout the 20th century: if cartography as defined by the International Cartographic Association represents the 'art, science and technology of making maps', then this thesis is concerned with the art, science and technology of the animated map. The art of the animated map is in itself not new: the originality of this research is represented by the science and technology, as will become apparent in the following chapters.

---

1 from C P Snow, Strangers and Brothers.

ACKNOWLEDGEMENTS

The research was carried out over the period October 1977 to October 1981 at the Department of Geography, the University of Durham; for three years of this time period I was in receipt of an SSRC studentship, for which I am very grateful. I would also like to thank Professor W B Fisher for accepting me both to the Department and to my college, the Graduate Society.

Grateful thanks go to Dr. David Rhind, specifically for acting as supervisor throughout this research, but more generally for introducing me to the world of automated cartography. Thanks must also go to the staff of NUMAC, especially Mr. Nigel Hall, and of the Rutherford Laboratories, especially Messrs. Paul Thompson and Paul Nelson, for making available local facilities, and for much help and guidance.

Very many individuals have contributed directly or indirectly to this research: thanks go to them all wherever they may be. Specifically, I would like to thank Tom Waugh of the University of Edinburgh for making available the program GIMMS; Peter Haddingham of Swift Film Productions, Wimbledon and Peter Wakelam, the University projectionist; Dave Rodgers of the New University of Ulster and Donald Grassie of Newcastle University, but both former colleagues; Dinah Michie, for bravely

proof-reading the entire thesis, and Peter Dodds, Bob Nelson and Peter Norris for much patience and encouragement.

Ultimately, I would like to thank my parents for years of help and support throughout my protracted education: to them I dedicate this work.

Helen Mounsey,  
Durham, 1982.

ABBREVIATIONS

The following is a list of abbreviations used throughout this thesis.

CB	County Borough
CRT	Cathode Ray Tube
COM	Computer Output on Microfilm
DC	County District
DES	Department of Education and Science
ED	Enumeration District
HDR	Housing Development Return
GRO	General Register Office
GRO(S)	General Register Office for Scotland
LB	Large Burgh
MB	Municipal Borough
NHSCR	National Health Service Central Register
NUMAC	Northumberland Universities Multiple Access Computer
OPCS	Office of Population Censuses and Surveys
OS	Ordnance Survey
PDF	Plot Descriptor File

RD Rural District  
SAS Small Area Statistics  
SB Small Burgh  
SERC Science and Engineering Research Council  
SSRC Social Science Research Council  
UD Urban District

## 1 AN INTRODUCTION

The detection and portrayal of subtle changes in variables through time over space is a problem which has beset man for many years. Essentially it is a problem of the portrayal of the fourth dimension, time. As early as the Stone Age, man had attempted to solve this problem in drawings and illustrations by representing animals with several sets of legs, portraying motion and change. But in spite of their intended design, such illustrations were manifestly unsatisfactory; they were in themselves static or non-changing. Or, as Riffe (1970) has noted

“for some purposes, the static map is not satisfactory. It is widely recognised that a single illustration, however good in itself, has definite limitations for indicating change through a considerable period of time”.

Traditional cartography (which includes all cartography up to the mid 20th century) was based on the static map - a simple sampled version of reality portrayed usually on a plane surface. The limitations of such maps for portraying change are based on their inability to incorporate the fourth dimension, time. Being static, the conventional map can only depict change in a phenomenon in one of two ways, both of which include inherent weaknesses. The first method is via the time series of maps. Here, in order to give some idea of motion or change, the cartographer presents a series of maps of the distribution of a phenomenon at successive dates in time. By itself, each map simply represents the distribution at any one point in time, and



it is only by a process of visual interpolation between maps that the map reader may identify change. However, Monkhouse and Wilkinson (1971) have argued such a process of visual interpolation (certainly with regard to population mapping) to be very difficult. A problem relating to the 'sampling interval' may also arise. Many processes operating on the environment do so over a considerable time period. The cartographer is then faced with a problem: whether to compile a large number of maps in order to capture the intricacy of the processes involved, or to compile fewer maps and risk the loss of detail. This is simply a cartographic version of a problem common throughout much geographical research - that of sampling - and one to which there is no perfect solution.

A second method whereby change in a phenomenon may be shown using static cartography is via the 'summary map'. This is a map of actual change in the phenomenon under study, and, by itself, shows no details about the basic distribution of the phenomenon. The same problem as with a time series of maps arises: either a number of maps covering several periods are necessary to capture detail, or one map may be compiled, featuring a longer time period at risk of losing detail.

A problem with all forms of static mapping is a simple lack of dynamism, whether in a time series or in a summary map. But, by definition, no means exist to incorporate any form of motion into the static map; what is needed is a new approach to the problem altogether. The aim of this thesis then is to examine one such

approach.

Moellering (1980) has defined two basic types of map, the real and the virtual. Thus far, the discussion has centred on the real map; this may be defined as being directly viewable (needing no special devices) and having permanent tangible reality - the map sheet. However, the application of automated techniques to cartography has given rise to a second type of map, the virtual map: Moellering defines this as lacking one or both of the above properties. Figure 1.1 makes the distinction between real and virtual maps clear, and provides examples of each type.

It is this concept of real and virtual mapping which offers a solution to the problem of portraying motion and change. For two forms of virtual map offer an opportunity to include the fourth dimension, time. These are film animation and video animation. The principle of animation is a simple one; if a series of images (pictures, maps, diagrams or whatever) which are related to each other are placed in time sequence on film, then, given certain conditions regarding colour, speed of projection etc., apparent motion can be seen on projection. Thus if a sequence of maps is presented in time series, change should be revealed in the phenomenon under study. Animated maps, then, are

'dynamic signs that move about and develop in self-explanatory ways to express abstract relations and concepts'. (1)

They may be used not only to reveal change in the phenomenon

---

1 Huggins and Entwisle, 1969.

Figure 1.1: Classes of real and virtual maps.

		Directly viewable as a cartographic image	
		yes	no
Permanent tangible reality	yes	<b>Real map</b> Conventional sheet map Globe Orthophoto map Machine drawn map COM Block diagram Plastic relief map	<b>Virtual map (type II)</b> Traditional field data Anaglyph Hologram (stored) Laser disk data Film animation Gazeteer
	no	<b>Virtual map (type I)</b> CRT map image (a) refresh (b) storage tube	<b>Virtual map (type III)</b> Digital memory (data) Magnetic disk or tape (data) Video animation Digital terrain model

After Moellering, 1980.

under study, but also to suggest explanations or identify the processes involved in causing such changes.

The raison d'être then for this thesis is to examine the use of the animated film in cartography via the creation of one such film. As has already been suggested (above), animated filming in itself is not a new technique. However, there are numerous ways to create an animated film, using many different types of map. Hitherto, many of the animated maps made have been created using highly specialised equipment on large budgets (see for example Moellering's own work described in section 2.2.1). Those created using more widely available resources have not been notably successful (see for example Massey's work described in section 2.2.3). This thesis describes the creation of an animated film using widely available resources, but which, it is hoped, achieves a greater measure of success than work done previously on this topic. It also utilizes choropleth mapping, no examples of which in animated filming are known to this author.

The following chapter provides an introduction to the theory of animation, and a brief resume of previous research. The strengths and weaknesses of various films are examined. The remainder then of this thesis describes an attempt to incorporate such strengths in, and eradicate weaknesses from an animated film as compiled by the author.

Without data, there could be no maps. Chapter three examines sources of time series data, but each of these is found to have

serious deficiencies. It concludes that only population data may provide a satisfactory time series. However, in chapter four, problems in using published sources of British population data are identified. Thus it was found necessary to construct one based on published sources, rather than to use these directly. This move in fact formed a larger part of the research than was originally intended; it is described in chapter four and continues into chapter five where the limitations of such a data set are examined. The resultant data set itself forms appendix A.

Chapter six considers the design of an animated film in relation to traditional cartographic theory. In spite of work carried out on animated filming by other authors and referenced in chapter two, there were still a great many unknown factors involved in the design of an animated map. In view of this and the great number of design variables, a 'trial and error' approach was adopted, and the results show significant departures from accepted cartographic practice. Chapter seven examines the creation of the film from map generation in Durham through plotting in Oxford and processing in London. The results of this seemingly tortuous process are enclosed with this thesis, and are examined in chapter eight. They are shown to be reasonably successful, although improvements could still be made given different areas of study, and different data sets.

Throughout this thesis, the Harvard system of references is used: a complete bibliography is to be found at the end of the

main text. A problem throughout the text itself lies in the referencing of volumes of population data based on the 1971 census: there were two sets of publications from this census, based on the pre-1974/5 (1) local government areas (the blue volumes) and the post-1974/5 areas (the yellow volumes). To distinguish them, the former are referred to as the 1971 census volumes and the latter as the 1974/5 census volumes, since this marks their date of publication.

---

1 England and Wales / Scotland

## 2 THE TECHNIQUE AND USES OF ANIMATION

This chapter examines first the principles of animation on which the remainder of this research is based. Following this are a brief history of animation and its uses in modern cartographic film production.

### 2.1 PRINCIPLES OF ANIMATION

Studies in the field of psychology (see, for instance, Kolers and Von Grunau, 1976) have shown that the eye will momentarily retain an image of an object once it is removed from the field of vision. If a series of images is presented in a sufficiently rapid succession (and given certain provisos regarding the use of colour), the eye can integrate slight differences between one and the next into a smooth motion. Known as 'persistence of vision', this is the essential principle behind the theory of animation.

The history of animation spans only the 20th century, and is summarised by Manvell and Halas (1971). A series of inventions by Edison between 1900 and 1910 culminated in the development of the cine projector. At about the same time, animation itself was 'invented' as a cinematographic technique when Emile Cole, working in Paris, drew a series of several thousand white pin men on a black background and photographed them in sequence.

Combining the two developments, animation rapidly achieved popularity; initially only in the field of entertainment, its use has spread latterly to television commercial production and education as well.

## 2.2 THE USE OF ANIMATION IN CARTOGRAPHY

The origins of animated cartography can be traced back to 1935, when the first film (essentially a series of still photographs bearing a temporal relationship to one another) was produced. The work in question is that by A C O'Dell on mapping population migration in Aberdeenshire over the period 1696 to 1931. Unfortunately, the only known reference to this work is in the discussion following Fawcett (1935) and it is not clear by what means the data were portrayed, or even its source. However, the maps would seem to comprise a series of vectors converging on Aberdeen. Considering the difficulties in presenting cartographically such a time series of data, O'Dell stated

^Recent work on the technique suggested filming as a means of escape from the difficulties. 17 maps were constructed for Aberdeenshire; whilst useful in eliminating 16 pauses in showing 17 slides it fails to give a picture of progressive changes. Four thousand maps would be required for the elimination of jerks in this short film, and since a jerk would take place every time a parish moved from one zone to another, interpolation for inter-censal years would still fail to give a smooth running picture^.

He concluded that

^I show this film then not so much as a way of showing dynamic changes of population but as an attempt which, while failing to reach the ideal, may lead others to a successful solution of a very difficult problem^.

In this discussion - taking place right at the outset of the use of animated cartography - O'Dell identified two problems which still exist today. The first is one noted in connection with this research in chapter 7; it is the problem of designing a series of maps which, when viewed in time series, form a smooth running picture. Secondly, O'Dell mentions the enormous number of frames needed to eliminate jerks, a problem examined in section 2.3.

Despite these problems, O'Dell's film serves to illustrate the functions of the animated map as outlined by Moellering (1978) and examined in chapter 1: in theory at least, the patterns of migration in Aberdeenshire should have been revealed, and some explanation of them formulated. It is doubtful whether O'Dell's film was of sufficient quality to enable this to take place; however, the basic principle remains the same, and has been proved in subsequent animated films, some of which are examined in sections 2.3 and 2.4.

### 2.3 THE DEVELOPMENT OF COMPUTER-AIDED ANIMATION.

The enormous number of frames needed in animation succeeded in causing the development of animated cartography to come to a

virtual standstill until the advent of computer cartography in the late 1950s. The only other work known to the author on manual animation seems to be that by Thrower (1959,1961) at the University of California. The films developed were primarily for educational purposes and portrayed moving maps of historical events. A major disadvantage at this time (together with the enormous number of frames needed) was the necessity for manual animation using animation desks and conventional photography. Basically each map was hand drawn onto a separate celluloid transparency (a cel), and positioned manually on the animation desk. A camera positioned directly above the desk then photographed a sequence of these cels, creating the film. As well as being time-consuming, the process required both a cartographer and a manual animator and could therefore be very expensive.

The growth of computer technology from the late 1950s onwards led to several contributions to the field of animation in general, and cartographic animation in particular. First, positioning of the cels became mechanised (Kallis, 1971). Two advantages accrued; the placement of cels was considerably speeded up, and the registration was also more accurate and less susceptible to error. Secondly, the development of the mechanical pen, or plotter, led to more easily and precisely drawn cels. This development introduced a need for a knowledge of computer programming into the process and in some ways was not a saving in terms of personnel. However even the earliest

mechanical plotters were faster than hand drafting and so potential advantages existed, especially in precision drawing.

The late 1950s witnessed the development of the cathode ray tube (CRT), the use of which became widespread throughout animation. To record the images in succession onto film, early computer animators used a camera mounted opposite the CRT, a system which was later developed into computer output on microfilm (COM).

The development of the CRT led to a huge increase in the availability of virtual maps. Maps became quicker to compile (drawing on a phosphor screen is much faster than drawing on paper), and cheaper to develop; if a hard copy (real) map was required, a copy was simply run to a pen plotter, or developed by photographic means. The increase in the availability of virtual maps and the speed at which they could be compiled led to the first major steps in computer-animated cartography, the problem of the large number of frames required now assuming less importance.

The first use of the computer for animation is believed to be in Knowlton's work around 1964 at the Bell Telephone laboratories in New Jersey (Knowlton, 1965). Using a CRT with a camera mounted opposite, Knowlton developed films for educational scientific purposes, including one of the actual process in use for the production of the films and one of a 'map' of celestial mechanics. A notable feature of this work is the development of the first complete animation language, BEFLIX (Bell Flicks),

which incorporated the concept of reusable basic subroutines. This idea was later developed into the idea of picture primitives on electronic cels where the animator could draw a particular feature, name it and subsequently call that cel back whenever needed. Scaling, windowing, rotating and masking - all basic concepts on the theory of animation - became feasible propositions; previously, they were all time-consuming and expensive.

In 1966, Cornwall and Robinson (both of Wisconsin) reviewing the work done on the making of animated motion pictures and their applications in cartography, noted the newest and most significant aid to animation, the idea of the light pen (Cornwall and Robinson, 1966). Basically a photoelectric tube, it achieved widespread popularity. In general animation, it removed the need for a knowledge of computer programming; by drawing on a graphic tablet the artist could draw each picture primitive freehand. Its use in this manner for cartographic animation was limited; it is impossible to draw a series of freehand maps without serious problems of both accuracy and registration within the map. However, used in conjunction with certain types of CRTs, it had marked effects. Maps already in digital form could be displayed on the screen. By making contact between the screen and the pen, lines could be added, changed or removed without either altering the basic program or exiting the program to edit the digital data base.

Aside from a general increase in computer size and speed, relevant hardware developments throughout the remainder of the 1960s were very few. The major development in software had little effect on cartographic animation; that was the development of electronic 'in-betweening'. In manual animation, it is common to have the main artist draw only the key frames depicting objects in crucial positions. Subordinates would then fill in the intervening frames to compose the film. Computer-animated film making had to some extent solved the problem of intervening frame generation by speeding up the basic drawing process. However, the development of electronic 'interpolation' for key frame animation now took the responsibility for intervening frame generation away from the animator; the animator need now only create the key frames, between which the computer would interpolate. The development of this technique was reflected in the profusion of new animation languages during this period (for a list see Anderson, 1971). Most of these could only accommodate simple picture outlines and are of no use to cartographic animators, with the possible exception of some of the very latest, for instance ANIMA II (see the review of Moellering's work in section 2.4.1).

The end of the 1960s marked the production of the first computer-animated films in geography known to the author - previous films having emanated from either the physical sciences or education. Tobler (1970), working at the University of Michigan, utilised a computer to predict the population of the

Detroit area to the year 2000. The resulting data, combined with the actual population from 1910 to 1970 were mapped as a series of block diagrams and filmed in sequence. Some of the frames of this film are presented in Tobler (1970), and seem to be an effective means of presenting and analysing such data, adding a new dimension to the urban modelling of that period.

Throughout the 1970s, the use of COM became increasingly widespread especially in static virtual cartography (for instance see Meyer et al, 1975 and Jeffrey et al, 1975). The development of COM also had implications in computer-animated filming. Early films, both cartographic and general in nature, had been photographed with a camera mounted directly opposite the CRT. This method is now considered to be unsatisfactory in that 'pin cushion' distortion may occur if the screen is not flat. Furthermore, if it is not properly shaded, light reflections may be seen. Lastly (and certainly on early CRTs), the line width was very wide in comparison both with traditional maps and with addressability on the screen: on a Tektronix 4010 storage tube, for instance, the line width is about four times as great as the plotting resolution. Although the principle of a camera mounted opposite a screen is apparent in a COM device, the whole system is totally encased and an optically flat screen is used.

The use of COM has also in part solved the problem of colour in animated films. Although early films were all in monochrome, technology dictated this; colour can theoretically be incorporated even in such primitive technology as long as there

are no rapid and abrupt changes in hue or intensity. Some such COM devices employ a system of filters containing the three primary colours. Increasingly efficient polygon shading programs allow the filling-in of areas; combined with the use of filters and colour film, shaded images can be produced, although true half-tone shading is not possible. In more sophisticated, raster display devices, each point can be assigned a hue and intensity and (sometimes) a half-tone shading can be achieved by varying the latter. The use of such raster devices is a development of the late 1970s with regard to computer cartographic animation; Moellering (1978) has carried out some studies in real time animation (as opposed to near real time as in COM techniques) recording on video tape units, with the advantage of instant playback for viewing; an example of this research is examined in section 2.4.1.

The computer-animation of maps then incorporates all the basic advantages of computer-aided cartography (see Rhind, 1977). The maps may be drawn more quickly and cheaply and repeated experiments may take place until the user achieves the desired image in terms of content and cartographic design. The use of computers for actual animation has solved in principle (if not always in practice) such problems as the accurate registration of cels; problems in the production of the immense number of frames required are no longer pre-eminent as each map may easily be redrawn in a slightly different form from the previous one, then rephotographed the requisite number of times. Finally the

increasing sophistication of computer-driven output devices has led to an improvement in the quality of the actual image, especially that achieved when using COM techniques.

#### 2.4 SOME COMPUTER-ANIMATED FILMS EXAMINED

Over the last decade, a number of computer-animated films depicting a range of subjects from student riots to the movement of weather systems have been created, verifying Moellering's (1978) assertion that

'conceptually, there is practically no limit to the kinds of data which could be dynamically displayed in this manner'.

It is neither feasible or desirable to examine every film in turn; not only would this become too lengthy a discussion but, in addition, many films - although referenced by authors who may have seen them - are never documented nor are they publicly available. Instead some systematic sample of films needs to be chosen. To do this, a classification of the methods of portrayal of graphic data must first be established, and one of these is illustrated in figure 2.1.

Although the word 'map' is difficult to define and can be applied to images ranging from fantasy and mental maps through to highly precise large scale topographic maps, traditionally it has associated three constraints (Robinson et al, 1978). First, the

Figure 2.1: A typology of graphic displays.

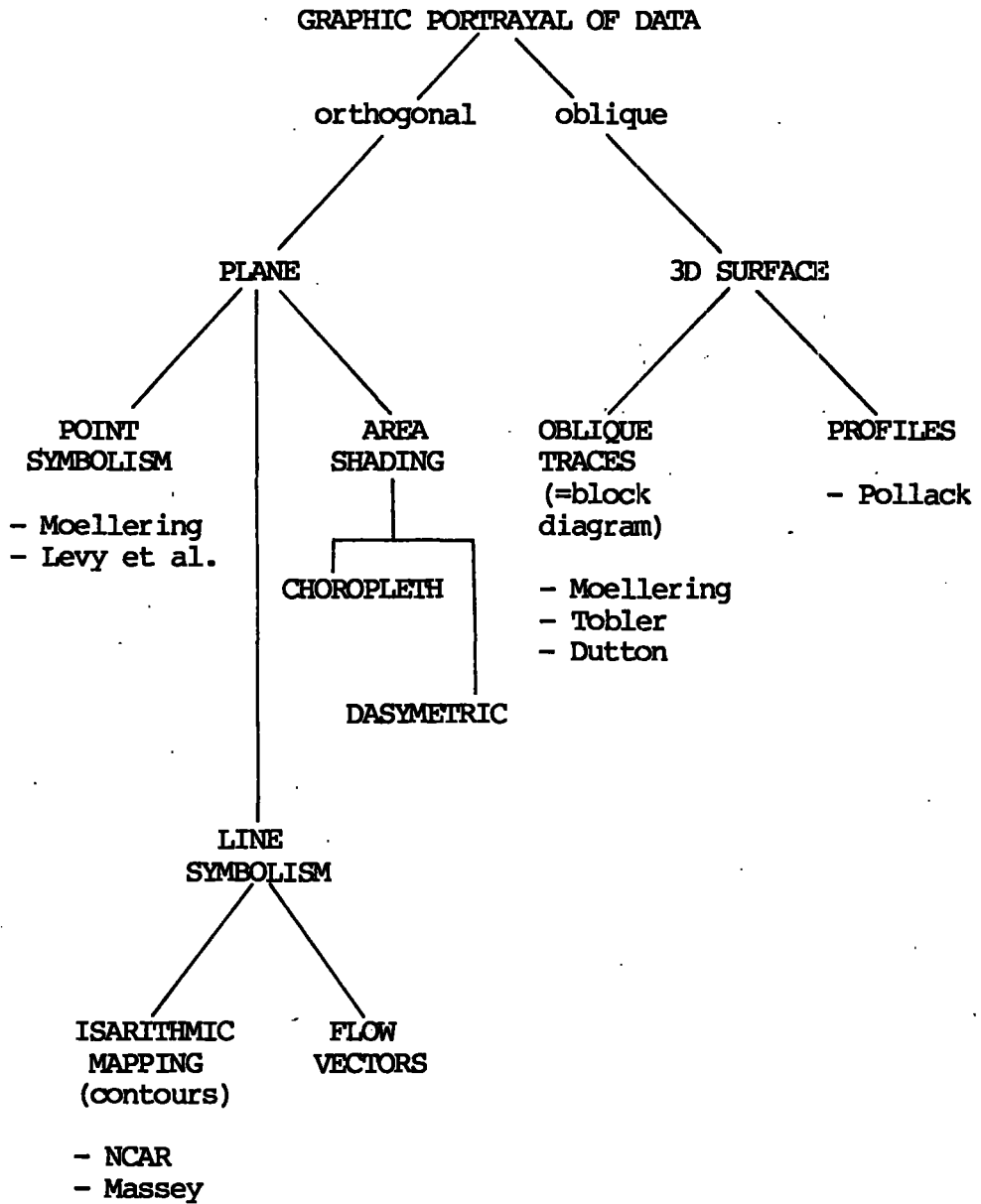

representation is dimensionally systematic - there is a definable mathematical relationship between the objects shown. This is the concept of scale, which is always present (even if variable across the map as in Kadmon's (1975) hyperbolic-scale maps). Secondly, a map is usually portrayed on a flat surface which is easy to handle and print on; two important exceptions to this are the globe and the three-dimensional relief model. Thirdly, and most important, a map is a generalisation of reality (Board, 1967); it can only show a selection of phenomena. This forms the distinction between a map and a photograph, the latter displaying anything to which the film emulsion is sensitive.

On the basis of the above three points, figure 2.1 illustrates a typology of graphic displays. Maps can be classified as either oblique or orthogonal and the former are examined first.

Oblique maps have found much favour within cartography in general, and animated mapping in particular. They depict the data as a three-dimensional surface and by using them in an animated film, it is possible to portray four dimensions at once, thus providing - in principle - rapid insight into the dynamics of the phenomena involved. Two forms of oblique maps may be defined; first are the oblique traces, more commonly known as block diagrams. The first strictly cartographic animated film, that by Tobler (see section 2.3), utilised the block diagram with considerable success. Yet it is perhaps surprising that the use of block diagrams has become so popular in animated filming; the amount of computer time taken in the generation of the image is

generally very large due to the complexity of algorithms for hidden line elimination within non-geometrically shaped surfaces. Whilst producing aesthetically pleasing results, such algorithms are often very slow. The problem is exacerbated by the prohibitive number of frames which must be generated (at silent film speed of 16 frames / second a film of five minutes duration requires 4,800 frames). A second problem in the use of the block diagram is the variability of scale across it (unless an isometric block is used), though precise measurements cannot readily be made from such films in any case. Aside from Tobler, the block diagram has also been adopted as a means of cartographic display by both Moellering and Dutton; in view of the importance of their contribution to the techniques of computer-animated filming, these works are examined separately in sections 2.4.1 and 2.4.2.

The second type of oblique display is the cross-section or profile, a two dimensional display of the X and Z axis. Although little used in animated cartography, Pollack (1969) has compiled a film depicting the geological formation of the Grand Canyon - a series of profiles which show the downcutting processes involved.

The other type of cartographic display is the orthogonal method, depicting data on a plane surface. This method can in turn be sub-divided according to the type of symbolism employed - point, line or area.

Point symbolism can be readily utilized in animated mapping. By employing a suitable type and size of symbol, events occurring

over a period of time can be correctly located in space on a background base map. This approach has been adopted by Levy et al (1970) in a film illustrating the seismicity of the earth, 1961 to 1967. The epicentres of seismic activity were depicted as symbols whose brightness was proportional to the magnitude of the event, correctly located on a background map of the world. The symbols faded through time, thus the events of greatest magnitude were visible the longest. Point symbolism was also used in a film developed by Moellering in 1973, although later extended up until 1976 (Moellering, 1973, 1976). The subject matter was that of traffic crashes in Washetnaw County, Michigan. Both the exact location and nature of all accidents in the county were recorded, the latter being divided into classes on the basis of the severity of the injury sustained. On a blue background map of the county, each accident was represented by a yellow star, the size and duration of display of which were proportional to the severity of the accident. On projection, several patterns appeared; a dispersion of accidents at weekends, on holidays, in bad weather, and on Wednesdays (for which no reasons were apparent). Not surprisingly, an intensification of the pattern occurred during rush hours. Subject to the need for a little local background knowledge, the film could be a very powerful tool in pattern recognition and hypothesis formulation.

Of computer-animated films utilizing line symbolism, there appears to be little written documentation. Films of tidal flows using vectors are known to have been made by Mungrell on National

Oceanographic and Atmospheric Administration computers in the USA and whilst working at the ECU (Bickmore, 1981, pers.comm.)<sup>1</sup>. Moellering (1978) refers to a film made by Wilson, illustrating air pollution by line vectors. Despite a lack of written evidence, there is little doubt that line vectors have been used elsewhere; they receive widespread use in television to portray the movement of phenomena.

The remaining type of line symbolism is the isopleth. Massey (1979) has attempted to make an animated film using shaded isopleth maps (discussed in section 3.4.3), and films depicting the movement of weather systems by isobars are known to have been compiled by the NCAR (Moellering, 1978).

The use of areal symbolism is not yet widespread in animated mapping, although there is no apparent reason why this should be so. Other than the research described here, the author knows of no instances of animated choropleth or dasyymmetric mapping.

Because of their outstanding contributions to the techniques of computer-animated filming, their especial reference to this research, and also because the author has seen two of them, the later works of Moellering, of Dutton and of Massey are now examined in greater depth.

---

1. D. Bickmore. E.C.U.

#### 2.4.1 The work of Moellering, Ohio State University

Having started work on animated computer graphics whilst at the University of Michigan (see above), Moellering continued this research on his move to Ohio State University. The author was fortunate enough to visit this establishment in March, 1979 and see the work in progress.

Within the University's Computer Graphics Research Center (CGRC) is a very sophisticated system for the production of computer-animated films. Although mainly used in science and education, Moellering was able to use this to produce a new film depicting the potential uses of computer-animated films in cartography. In terms of hardware, the system consisted of a PDP 11/45 as a mainframe processor with 64K of core memory (which proved to be the limiting factor in the animation of complex objects). Linked to this were a 3330-type disk drive, a real-time refresh display CRT and a video generator for production of video signals for subsequent recording and display.

This animation system is one developed since 1973 at the CGRC, under the direction of Charles Csuri and financed principally by a National Science Foundation grant. The animation language, ANIMA II, was developed to allow a person with no computing background to develop an idea into a finished film recorded on video tape in real time (Hackathorn, 1977). Written in Assembler for increased efficiency, it allows a four stage process to take place. First the creation of complex polyhedra and the modelling

of these in real time is performed. Secondly, an animation script is written, using the concept of key frame animation outlined in section 2.3. Thirdly, the actual animation process takes place using a visible surface algorithm to calculate the final displayed output, which is stored in binary form on disk, and finally, this stored sequence is displayed and recorded, again in real time, for subsequent viewing.

Polyhedra are initially created and displayed on the CRT; at this stage they are transparent 'wire frame' structures, with no hidden line removal having taken place. They may be manipulated by the user - warped, distorted, expanded, merged etc. - and may also have colour assigned to one or more of the faces. Due to hardware considerations, each object was at the time limited to about 2,500 edges, but the subsequent replacement of the PDP 11/45 has greatly reduced this limitation. The time taken for the creation of these objects varies; the creation of a regular 16-sided object recorded on film took five minutes, including some subsequent manipulation. However a frog seen on a later film took approximately three hours to generate.

The second stage of the process is the creation of the animation script. This is based on the standard story-board animation, transcribed into a list of instructions written in the ANIMA II syntax. Essentially movements are scheduled to take place over a certain number of frames as designated by the user, who also specifies the 'change to' position, the program calculating the vectors necessary to reach this position. As

well as controlling the actions of objects, the user may also control the whole screen, with conventional terms such as zooming, panning and tilting altering the relationship of one object to another, and both objects to the observer. Background colour and lighting requirements are also specified at this stage.

Having written the script, the third stage of the process (actual animation of the objects) may begin. This in itself is a two-stage process. First, the objects (still in their uncoloured wire frame form) are 'animated'; using key frames as previously specified by the user, intermediate positions for all objects over the required number of frames are computed i.e. corresponding to manual in-betweening. At any time, short sequences of the film may be viewed on the CRT if the appropriate commands were specified when writing the script. Secondly, using a visible surface algorithm, objects are solidified and coloured, with background colour and lighting parameters added. Run time taken for the entire third stage is between five and ten minutes, for a 300 frame (10 second) sequence, depending on the complexity of the polyhedra involved. Completed sequences of film are stored on the 3330 system disk, until required by the fourth stage of displaying and recording. Using a double buffering system, information is read from disk and then decoded; reading and decoding takes place in real time on a standard television screen. Also incorporated is a raster scan decoder, which interfaces to a colour video system for recording the image.

For block diagram presentation, the ANIMA II system produces some very high quality animation, whilst at the same time retaining a high degree of flexibility. Perhaps its over-riding advantage however is that of efficiency. It may be used by operators totally unfamiliar with computing systems, yet skilled in areas of artistic animation. Furthermore it is quick, with a fast turnaround time and rapid production of results. Films produced so far have been chiefly in the areas of art and education but uses have also been made of the system for astronomy and statistics, as well as the film made by Moellering depicting the uses of cartographic animation.

Moellering's film consists of three parts, each studying a different topic, and each illustrating a different approach to the subject. The first section portrays a simple digital terrain model as a solid figure in colour. Using ANIMA II, the model is rotated and the Z surface explored by alteration of the viewing point.

The second part is an example of the depiction of population data, illustrating the growth of the United States population by state between the years 1850 and 1970, and shown by mapping population density data derived from the decennial censuses as a block diagram. Whilst not a new approach to the depiction of population data (see Tobler's work described in section 2.3), this example is a good illustration of the flexibilities of ANIMA II. The object was rotated about the Z axis every 20 years to provide an overall view of the population density. Furthermore,

the states of New England and the Mid-Atlantic coast, being areas of relatively high rates of growth at the start of the period, are portrayed as an inset to provide a clearer picture of the processes involved. In order to portray these states satisfactorily and also because of hardware limitations, each state involved is created separately and 'moved' to join the previously created states, thus providing a clear and detailed picture of the growth of the population.

The third section of the film comprises a cartographic portrayal of an example of the Monte Carlo model of spatial diffusion of an innovation. The subject used in this case is the diffusion of the innovation of the farm tractor from its origin in the state of North Dakota in 1920 through to 1969, by which time the number of tractors in use was actually in decline. As in the previous example of population growth, the year depicted is represented by a horizontal bar along the bottom of the picture, 'growing' from left to right through time. Moellering (1979, pers.comm.) claims that experiments had proved this to be a clearer and less obtrusive method of depiction than by the conventional use of a clock; visually it appears to be very satisfactory.

The above work has verified the suitability of animation for the cartographic portrayal of spatio-temporal data. However, whether real time animation using video techniques is presently a feasible proposition for anything other than very general, low-resolution cartographic displays is debatable. Moellering's

block diagrams are simple in nature and solid, with no narrow lines; thus the jaggedness at edges produced as a result of the bandwidth limitations of a television signal is not important. However, in presenting the typically finer lines associated with an orthogonal base map in two-dimensional mapping, low resolution could be a problem. Yet the advantages of using video recording techniques are substantial; although film offers higher quality in resolution and contrast, it must be chemically processed before viewing. Video results can be viewed immediately, and the tape re-used. A further advantage of video is that colour is a natural component; in filming, filters have to be used. In the use of video, however, the hue and intensity of every point in a scan line must be computed, thus the amount of computational time taken can be immense.

For conventional animation, the system in use at the CGRC is excellent. This author, however, has doubts about its use for widespread cartographic animation. In the first instance, its comparatively low resolution restricts its use in this field. Secondly, there is a more general problem - it is a highly localised facility. The system at the CGRC has, from the beginning, had large sums of money available, and is indeed run as a commercial animation unit, with a high class animation language and sophisticated hardware under constant improvement. By the standards set there, computer animation by any other method is at an extreme disadvantage - in such as a lack of a proper animation system, slow turnaround time and the lack of

video recording facilities. But the extreme expense of such a system is beyond the means of many wishing to do small scale high resolution cartographic animation. There seems little doubt that most cartographic animators will continue to utilize the more widely available COM techniques for some time to come.

#### 2.4.2 The work of Dutton, Harvard University

Working at the Laboratory for Computer Graphics and Spatial Analysis, Dutton (1978) has produced an animated film of American population growth between 1790 and 1970. The distinguishing feature of this film is the simplicity of the method of production. The data used are taken from the decennial census of population, starting with the first in 1790 and held every ten years since that date. They are portrayed as three-dimensional block diagrams making use of a hologram for display.

The first stage of research involved in the making of this film was to assemble the historical census data, and reformat it to a form acceptable to the chosen graphical display program. The data were obtained from a body similar to the SSRC Survey Archive, the IUCPR located at the University of Michigan. Because the areas to which the data refer have changed over time, the following strategy was adopted to cope with this problem. First, the data area and centre of gravity of each of the polygons was calculated. Using these, the population densities

for each of the decades for which data were available (ranging from nineteen on the East Coast to only five in parts of the Rockies) were calculated and the resultant values assigned to the centre of gravity of the polygon. Thus an irregular spatial distribution of data values was obtained, from which a regular grid was derived by interpolation, together with one binomial smoothing to remove abrupt changes in values. The resulting nineteen regular grids (one for each year of the census) were then argued to be a reasonable model of the distribution of the population - irregularities in both the original data and also in the process of data generation were felt not to matter as the scale of the finished 'map' was very small and also because only a general impression - rather than accurate data - could be presented by means of an animated film. The data were then displayed using a modification of the program ASPEX (Automated Surface Perspectives). ASPEX itself is a modification of the SYMVU program; it is designed to run interactively, as well as in batch, and has the capability of handling larger matrices. Temporary additions to the program enabled the derivation of data grids for intermediate years by linear interpolation; thus 181 maps were eventually produced, one map for every year. As with SYMVU, both the altitude and the azimuth of the viewing point must be specified by the user; this enabled the latter to be shifted in a counter-clockwise direction so that the block appeared to rotate through time, ensuring no area was permanently hidden from view. The altitude was also raised through time as

population densities (and therefore the 'relief' of the model) were low at first and were enhanced by low altitude viewing. Towards the end of the time period the marked 'peakedness' introduced by densely populated cities was reduced by high altitude viewing.

The 181 plotfiles created were copied to magnetic tape and taken to a service bureau in Boston, who owned an FR80 microfilm plotter. This differed from the one to which this author had access in that it was set up as a microfiche production device with additional hardcopy output, but with no facilities for the handling of sprocketed 35mm or 16mm film. Hardcopy output was therefore chosen, and the results were subsequently filmed using conventional 16mm black and white film, incorporating titles and the date of each particular map in the process. Using a professional animation stand, five frames for each map were recorded on film - 'persistence of vision' was thought still to be effective over this relatively high number - and a film lasting approximately 45 seconds was created. This film could then have been shown in the conventional manner, but was instead 'projected' as a cylindrical rotating hologram. Developments in holography at the time the film was made did not allow the use of colour; however, the image appears coloured due to the refraction of the light source used for illumination. It was decided to leave the image as a photographic negative, thus the block appears on a black background.

A notable feature of Dutton's work is that it is made on a much smaller budget than any of Moellering's films. If the final stage using holography is omitted, the method used is well within the means of most researchers examining time-changing phenomena. Unfortunately Dutton did not actually cost the film; the work was done on the MIT IBM 370 computer rather than the Harvard machine. However, the first stage need not have been unduly expensive - the programs were not written especially for the project, and microfilm recorders with output to hardcopy are widespread (if commonly on a bureau basis). Furthermore, the Laboratory has all the common disadvantages - no specific animation system, slow turnaround time (especially the use of bureau plotting facilities) and a lack of necessary hardware - but, despite these, another example of the animated film has successfully been produced.

#### 2.4.3 The work of Massey, University of Melbourne

Massey (1979) has developed an automated procedure for the production of colour animated films depicting rainfall in the state of Victoria, Australia, for the period 1905 to 1977. Although very simple in approach, and certainly not as sophisticated in technique as either of the two previous works, the film is notable in that it is the only known attempt to utilise two-dimensional area symbolism in animated mapping other

than that by this author.

The state of Victoria is divided into 37 counties, each with a variable number of rainfall stations. The average rainfall for each month of the 73 years was calculated by county and assigned to a 'synthetic' station located at the centroid of the county. After smoothing the data to remove very short term fluctuations, a decile approach for the determination of class intervals was adopted. The range of the 73 values for each individual month was taken and divided into ten. Thus there are twelve sets of class intervals generated, and each individual month can be assigned a number between one and ten on the scale for that month. Massey was subsequently interested only in decile ranges 1 and 2 (which represent very dry conditions for that month and that area) and decile ranges 9 and 10 (very wet).

The data, along with all the X Y county boundary coordinates, and those of the synthetic stations, were input into the SYMAP program. The program took the decile range value assigned to the centroid of the county and classified it to class 1 (decile ranges 1 and 2), class 2 (decile ranges 3 to 8 inclusive) or class 3 (decile ranges 9 and 10). The values of all intervening areas were calculated according to these classes. Thus each of the resultant maps had just three classes of shading. Each class was output as a separate map (to use subsequently as a colour separation), printed in the densest character ('O', 'X', 'A' and 'V' overprinted) - this is supposed to ensure the optical printing of uniform, high density colours.

The next stage involved the printing of each map separately on black and white 35mm film, using an Information International Inc. (III) COMp 80/2 microfilm recorder (a character version of the FR80 device). As with Dutton's work at Harvard, it seems this COM device had no facilities for 16mm film although it was capable of handling 35mm film. Thus 2,628 maps (73 years x 12 months x 3 sections / month) were each output as a separate frame.

The final stage of the process was the creation of a 16mm colour film from the black and white 35mm film. An optical printer was used (a combination of projector and camera). Incorporating the use of filters, the first section of the first month of the first year was photographed from the 35mm film. This was repeated 29 times to give 30 frames / month (and therefore a little over 1 second / month on projection). The first section of each month was "stretched" to 30 frames until the last month was completed, whereupon the entire film was rewound, and the process repeated with a different filter on the second section. Finally the third section was completed, and the 16mm film developed for subsequent projection.

The film runs for 20 minutes; Massey claims it to have cost less than \$1000 (early 1979) to make, although he did not include the cost of computing the original SYMAP sections. The system used, however, is very primitive and could be made more efficient if a 16mm camera was available at the second stage. This would render the third stage unnecessary and, since the optical

printing took 12 hours (compared to one hour for the microfilming), the process would be speeded up quite considerably even though colour printing and 'stretching' would increase the microfilming time slightly. Furthermore, the third stage involved operator intervention both in repositioning the 16mm colour and the 35 mm black and white films between every section of every month and also in rewinding both films for the second and third colour printings.

Rhind (1980, pers.comm.)<sup>1</sup> claimed the film to be brashly coloured and jerky and, after a short time, dull - little substantive meaning was extractable without a detailed local knowledge. Examination of stills from the film by this author has confirmed this as far as is possible. Despite these criticisms, it is the only known example of the use of two-dimensional area symbolism in this field. Shaded isopleth mapping is not dissimilar to choropleth mapping - the difference being that the former maps to interpolated outlines whilst the latter uses predefined areal units. As figure 2.1 shows, there are no known examples of the use of choropleth mapping in animated films: this is astonishing given the widespread use of the choropleth technique for standard static maps.

The aim of this research then is to investigate the use of the animated film in cartography: it so happened that the type of map used was the choropleth map (see section 6.1). The author has access to facilities which, although inferior to Moellering's, were superior to those available to Dutton or to Massey - an

---

1. D. Rhind. Durham University

up-to-date choropleth mapping program (c.f. the use of SYMAP developed in the late 1960s and designed for line printer output), and a sophisticated microfilm plotter with a wide choice of output devices (although the two were on different computers and linked only by the transfer of plotfiles on magnetic tape). The first stage in the creation of such a film is the identification of a suitable data set for mapping. The next chapter examines possible sources of such data.

### 3 SOURCES OF TIME SERIES DATA

Waugh (1974) describes the 'geographic process' as

'the transformation of geographical data into information as perceived by a research worker or other user'.

It is without doubt that the map plays an important role in such a transformation (see for example Robinson and Petchenik, 1975), and much substantive research into cartographic methodology has arisen as a result of a desire to increase the efficiency of the map as a means of communication. New techniques in cartography have often been developed in response to a need to portray a particular type of data set more effectively - 'we have this data set, how can we best map it?' Examples of such are Tobler's (1973) work into the use of continuous shading with particular reference to the mapping of population density and, more recently, Visvalingam's (1978) research on the use of chi-squared mapping for census variables.

The research described here inverts such an approach; the author had no particular data set in mind when she decided to investigate the possibility of using maps as displays of circumstances which change over time. The production of such a map requires time series data and, as a consequence, one or more suitable time series had to be found. Given the frequently expressed interest in the geographical literature with changes over time, it initially appeared that obtaining a substantially important and appropriate data set would essentially be a matter

of selection. This chapter describes the search for such a data set: in this search, fundamental limitations to the continuity in many existing time series are exposed.

The collection of a time series data set requires an answer to two questions: what type of data set is needed and how is it to be collected? This chapter first examines data requirements, and second, data sources. The third section examines problems arising from a mis-match of requirements and sources, and concludes that probably only population data sets provide even a partial solution. The final section examines in greater detail possible sources of time series population data.

### 3.1 DATA REQUIREMENTS

The environment is shaped by processes acting upon it; the role of the animated film is to illustrate change induced by these processes on the environment. However, a film cannot be made simply by recognizing the existence of such processes; they must first be represented in a qualitative or quantitative form - for instance whilst migration from the north to the south of England is known to have taken place throughout the 1960s, it is not possible to make a film of this without data. Thus what data are needed, and how are they to be collected? Figure 3.1 is a diagram of the data collection process. Within a frame representing the method of data collection itself, the actual

Figure 3.1: The data collection process.

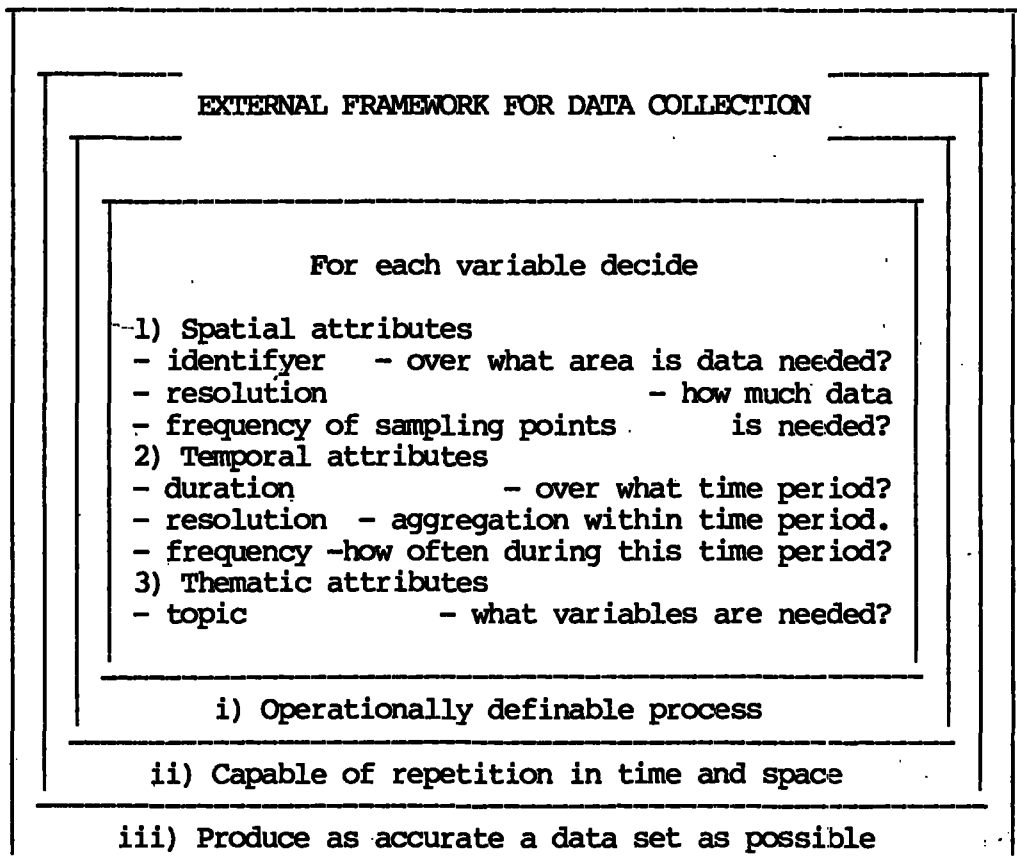

attributes of any one data set are summarised. In building a data set, the aim is to determine the attributes of the data required, and then collect data with such attributes in accordance with the guidelines for data collection (see the external framework in figure 3.1). Data attributes are examined first.

Geographic phenomena exist in time and space and have a value (Waugh, 1974); each of these attributes has to be identified and recorded. Theoretically each datum has five dimensions - the three dimensions of space, one of time and one of value. Conventionally the third (Z) dimension of space is ignored (unless it represents that of the value as in topographic surveying). Also, if all the data pertain to a single moment in time, storing the time dimension is of little importance. The five dimensions between them represent the spatial, temporal and thematic attributes of a data set, and each will be considered in turn.

All geographical data contain some form of location identifier - the spatial attribute. Usually this relates to physical space although more recent perception studies have utilized 'mental' space (see for example Gould and White, 1974). The researcher, in specifying his data requirements, must first define the area over which the process operates, and then apply some form of co-ordinate referencing system to enable data to be related to a common geographic base. In cases where the researcher has to resort to using archival data (rather than self-collected data),

the spatial attributes of any data set often cause the greatest problems, not only in the creation of 'time slice' sets (for instance across American states, where each state may use its own plane co-ordinate system) but (more seriously) in the creation of time series sets where change in areal definition through time is often a severe problem. This point will be examined at length later.

Spatial attributes of a data set also include the spatial resolution and the spatial frequency of sampling points. The former denotes the size and type of collection unit over which to aggregate the data, and the latter, the number of sampling points. These two attributes are closely related, and unless defined at the correct level and density, can result in either vast amounts of collected but redundant data (which in turn leads to increased processing time to reduce it to a more manageable or usable level), or insufficient data from which to obtain valid results in a later statistical analysis.

The second attribute of a data set is its temporal element. In 'time slice' data sets, this element may be ignored but in time series sets, a time scale over which data is required must be defined - the temporal duration, or total time period. The temporal resolution must then be considered, this being the period of time throughout the temporal duration over which the data are to be aggregated, a factor of prime importance when dynamic features are involved (for instance the number of births each year, by year). The temporal frequency of sampling also has

to be specified - how often throughout the total time period data have to be collected. This will obviously be higher if an accurate picture of rapid change is to be acquired. Furthermore, if the pattern of change is cyclical, then it is necessary to ensure that the sampling intervals do not coincide with this and that they are taken at a maximum of half the cycle. A problem encountered when sampling non-cyclical change is that it is never clear whether the duration of the observation period has given an unbiased picture or not (Muehrcke, 1979).

The third attribute of any data set is that of the thematic element. In data specification, the variables most likely to give the clearest picture of the process under examination must be identified. There may be any number of these, ranging from one (for example the volume of water passing a gauging station to show changes in river flow) through several (the monitoring of births, deaths and migration to establish population change in an area) to many (when examining complex processes such as the changing economic base of a developing country). The problem of surrogates must also be considered if a particular variable is unavailable (for instance 'change in car ownership' for wealth).

Having defined the type of data set required, it is then necessary to determine a method of data collection. Usually, in any data collection process, the aim is to create a complete data set, without gaps and omissions, but also without redundant or unusable data. In order to achieve this, and to give a true and accurate picture of the processes under study, the method of data

collection (represented by the framework in figure 3.1) must meet three conditions. The first is that this framework for data collection must represent an operationally definable process to ensure that the resultant data have some kind of meaning, use and structure (Dawson and Unwin, 1976). Secondly, to ensure consistency within the actual data set, reproducibility of outcome of the measurement operation must be ensured - that repetition of the procedure will produce <sup>same</sup> comparable results. This is particularly important when considering time series data in that the actual method of measurement should not change between subsequent time periods: if this is the case, then the results do not form a strict time series. Lastly, quantification must be valid - all measurements should be as true and accurate as required for the task in hand. This requirement should be obvious - and if the framework for data collection is a well-defined and repeatable process (see first and second points), then this will normally follow automatically. However, it can be inadvertently or otherwise violated such as by the bias shown to exist in the 1961 Census of the Population (GRO/GRO(S), 1968). Although in the main that census was of 100% coverage, the collection of some variables was based on a 10% sample. It was left to the enumerators to provide every tenth household with a longer set of questions enquiring about the extra topics. In the interests of obtaining a 'representative' sample of the population, many enumerators omitted households of elderly persons, immigrants etc. and substituted 'normal' households

instead, thus in fact biasing the results. The method of enumeration was well defined, and repeated throughout the country, but the data set is not representative of reality. Although OPCS has published correction factors for this error, the biased data (representing information on economic activity, education, household composition and migration) must be used with care in any time series.

It is in the reconciliation of the external framework of data collection to the internal attributes of the data set that the problems lie: it is often possible in a time series to meet the needs of one without fulfilling the other. Examples will illustrate this point. The Census of Population is an operationally definable process: the Census Act of 1920 states how it must be held. It is capable of repetition, not only throughout Great Britain, but also through time (every 10 years). It is generally believed that the resultant data are as accurate as possible. Such principles are achieved however at the cost of the internal attributes of the data set. Spatial attributes differ (changes in data area). There are small differences in temporal attributes (notably the alteration of the 1921 census date) and substantial changes in the thematic attributes (i.e. changes in the questions asked).

In contrast, consider any two successive years of mid-year estimates of the population prior to 1976. The spatial attributes are more likely to be constant (boundary changes are less likely to occur over a shorter time period). The temporal

attributes are certainly constant - the data refer to the same date (30th June) every year. The thematic attributes are usually constant: the data represent the total population (except for the years during the war when they represent the civilian population only). Against this, however, is the problem in consistency in data collection methods. Up to 1976, the method of estimation was changed every year as different data sources were used. Thus whilst repeated in space, in reality change in the method through time produces false comparisons between years. Furthermore, whilst the results are as accurate as possible, they are still only estimates - with all the limitations this term implies. The attributes of the data set have been held constant at the expense of the method employed to collect the data set.

The building of a time series data set then is often a question of juggling methods versus attributes. The researcher may specify his data requirements and methods of collection along the above guidelines. However, he should be prepared to make widespread modification in specification in order to obtain any form of data set at all. For, despite man's increased desire for more up-to-date information regarding the terrestrial environment (linked to the necessity for understanding, controlling and even modifying processes acting upon it) and despite an increasing need for data to test statistical techniques borrowed from other disciplines and applied to geography since the Quantitative Revolution of the 1950s (Burton, 1963), a dearth of reliable, timely and pertinent data still exists especially for time series

studies. Perhaps this increased demand for data is not yet 'old' enough for good time series to emerge and, with the development of modern computer information systems, such a situation will be remedied in the future. However, as the next section will show, there are as yet few strictly comparable data sets which form time series available.

### 3.2 SOURCES OF TIME SERIES DATA

Figure 3.2 represents a typology of geographical data sources (after Taylor, 1977), which may conveniently be applied to sources of time series data in particular. The diagram shows a hierarchical breakdown of such sources, in the first instance, into two types: field observations and archival data. It should be noted here that the division of data sources into survey and archive data is somewhat arbitrary: as will be seen by the examples which follow, data collected by survey methods by one researcher may subsequently be stored and used as archive data by another. However, despite its arbitrary nature, the classification is still useful in that it provides a basis for the examination of data sources.

Figure 3.2: Geographical data sources.

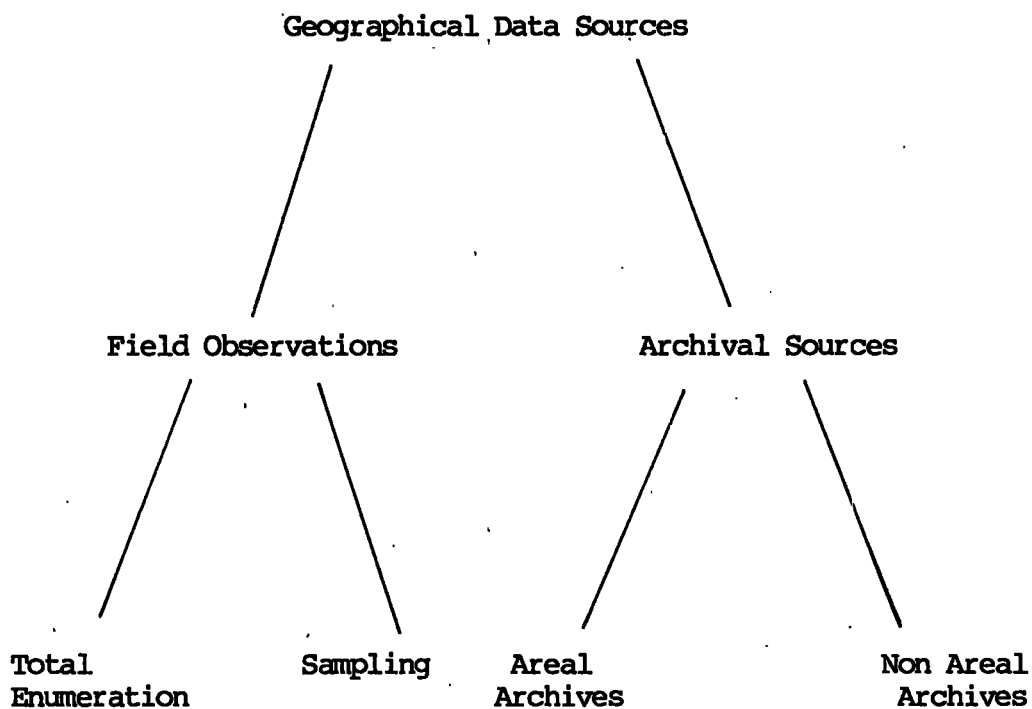

After Taylor, 1977.

### 3.2.1 Survey v. archive data

Survey data have long been favoured by geographers, and, for many, still remain the basic data source. The principal advantage of data collection by field survey is that the researcher may adhere to the previously outlined data needs more closely, and collect data specifically for the research in hand. The disadvantage of field survey may be summarised as its sheer impracticability if the field of study is large; it is expensive and difficult to standardize (Rhind and Hudson, 1980). In studies which require time series data, a further problem arises. Many processes operating on the human environment and of interest to those studying change (for instance population change or economic development) take effect only over one or a number of decades, and the processes operating on the natural environment may be even more lengthy, extending to the geological time scale. Over such a period of years, geographers have not the time or funds available to survey processes operating in the field (with certain exceptions, notably in physical geography) and thus have to rely on data collected by other researchers and administrators. These then become available to them in the form of archival data. Whilst survey should not be ruled out entirely as a method of time series data collection (see for example Gibbs and Howell's (1972, 1974) work into the collection of a time series of data on the diffusion of Dutch Elm Disease) it was considered impractical for the research in hand. Thus, as a

source of data, it is not considered further; for further details the reader is referred to Tomlinson (1972).

### 3.2.2 Archival data

The use of archival material is widespread among researchers, particularly if the field of study is extensive, and collection and processing of data for studies of areal differentiation is beyond the competence and / or resources of the individual researcher. The over-riding advantage accruing to the user of archival data is that it has already been collected, only requiring manipulation (although this is sometimes a considerable task) and final analysis. However, there are a number of disadvantages associated with its use, chiefly that the available data may not be of the required type or cover the relevant area: such problems will be examined later in the chapter. Figure 3.2 shows a subdivision of archival data into two sources: areal and non-areal archives. Non-areal archives make by far the largest contribution as a data source, but areal archives can also provide some valuable time series data, as is now examined.

### 3.2.3 Areal archives

Areal archives fall into three classes; maps, aerial photographs and satellite imagery. Maps tend on the whole not to give rise to a great deal of time series data. Data on thematic maps have usually been classified or grouped in some way, and therefore accurate values may be hard to determine (if indeed it is possible to determine anything other than nominal or ordinal data). Many thematic and topographic maps are revised only infrequently and spasmodically, thus being of little use (although against this must be set the continuous revision of large scale plans; in Britain, revision occurs whenever significant change occurs within a map sheet). Despite this, maps contain a large amount of information relating to land use (Rhind and Hudson, 1980) even if careful interpretation is required before it can be converted to geographical data. Fordham (1975), in his study of land use change in the second half of the 20th century, was able to use the "one inch" OS topographic map as his data source. Revision of this scale of OS maps has been carried out over the entire UK twice since 1945, and in some places three or four times. Using this series in conjunction with the 25 inch series (for urban areas), and the six inch series (for rural areas), Fordham was able to determine land use at various points in time and compile a record of change. Use of maps proved to be a more feasible method than a primary land use field survey, or even making use of secondary

sources such as the Statutory Register of Planning Applications maintained by all British local authorities.

Use can be made of aerial photographs to construct a time series data set relating to environmental change, although this is often only of the nominal presence / absence type. Experiments with photography taken from airborne balloons in the late 19th century produced the first topographic maps from this source, and the principles of photogrammetry were outlined by about 1900. Commercial firms were established during the 1920s and thus in some areas a 50 year photographic record is available for the derivation of data sets relating to large areas at a small scale (dependent of course on the subjective nature of aerial photograph interpretation). Hubbard and Grimes (1974) have shown the spread of Cord Grass (Spartina sp.) in Poole Harbour from 1924 to 1952, using areal photography. In general, however, comparable air photographs over a time period are difficult to obtain, and in any event, interpretation is usually labour-intensive.

The third and last class of areal archives also constitute the best source of time series data within this section, that of remote sensing imagery obtained from satellites in orbit around the earth. This is usually at a very small scale, and is not yet normally used for topographic map production, although some interesting time series studies have made use of it as a data source (see below).

The most widely used imagery is that emanating from the Landsat series of satellites. Three Landsat satellites have been launched (Harris, 1979); unlike other satellites, they are (or were) almost entirely engaged in the acquisition of imagery for use in the widest possible range of earth resource disciplines, including cartography (Chismon, 1977). Orbiting the earth at an altitude of 920 km (560 miles), 14 times a day, the track is almost exactly repeated every 18 days. As the orbit is sun-synchronous and near-polar, almost complete global coverage is possible, under optimum lighting conditions. Even allowing for the effect of cloud cover on the availability of imagery, this gives rise to an excellent source of synoptic data for the study of land use change over a period of time: the area covered by each image is 33,485 sq km so delineation of features is necessarily at a very small scale (although theoretically the resolution of the image on the ground is a square, 79 m by 79 m).

Landsat imagery is scanned, with the results recorded in digital format. It is then converted to photographic form having been transmitted back to earth. The availability of the "image" in two forms then gives rise to two separate methods for extracting time series data relating to change in the environment. Graphical detection of change consists of the manual interpretation of two or more photographs in time series; comparison of the results should reveal change in the phenomena

under examination. On the other hand, each pixel (1) in an image (still in digital form) can be compared to the corresponding pixel in another image in time series if the images are suitably registered. If there is a substantial difference in the level of radiation recorded, then change in land use could be deemed to have occurred. This represents the technical detection of change.

With reference to figure 3.1, neither method represents a perfect framework for the collection of data to illustrate change in a phenomenon. The graphical method is subjective, and repetition (especially between different operators) can produce markedly different results. It is also time-consuming, a factor of great importance if much imagery has to be analysed in order to build up a lengthy time series. On the other hand, the technical method is much faster (since it is mainly a case of ratioing two corresponding pixel values, a process easily automated), and (with reference to figure 3.1) forms an operationally definable process, capable of repetition through time and space. However, the quality of results (the accuracy of the data) is presently poor. Imagery is often degraded in temperate zones by atmospheric conditions (especially cloud formations) and although the manual interpreter can account for such problems (but not solve them), in technical interpretation at best they simply produce unwanted 'noise'. This method could be improved by incorporating some manual interpretation to remove

---

1 Pixel = 'picture element', or cell of minimum resolution.

such basic problems, and of course both methods would benefit from additional aerial photography at a higher resolution to aid manual interpretation.

Most examples of the use of Landsat imagery for change detection which are found in the literature utilize qualitative data collected by the graphical method (manual interpretation). Carter et al (1977) describe work done on the Reading, Berkshire area. Although obtaining sufficient cloud-free imagery poses a problem for research on the British Isles (especially if it is to be in time series), they were able to determine five categories of land use (water, open space, woods, urban areas and high density urban areas or heavily industrialised areas) from a series of images. By mapping successive interpretations, it was possible to establish change in any of these land uses. Place (1976) has carried out a similar exercise on the Phoenix, Arizona, area and, by incorporating aerial photography taken from a NASA U-2 high altitude aircraft over the same period, has produced rather more detailed maps of land use change. This emphasizes the need for the incorporation of aerial photography in the process if at all possible; the maximum amount of detail is obtained whilst maintaining the advantages of the use of Landsat imagery (timeliness, a synoptic view and relative low costs).

Landsat imagery can also be used to determine change in other than urban areas. In conjunction with high altitude aerial photography, Rehder (1974) has illustrated changes imposed by

strip mining, and its associated deforestation and reclamation, on the landscape in Tennessee. He has also examined agricultural patterns in the state, demonstrating a change from pre-ploughed (light) to planted (dark) to growing (light) states, and a wavelike movement north as planting becomes later in the year. Finally, Rehder describes the mapping of the Mississippi floods during the spring of 1973, comparing a time series of images to demonstrate the process of successive flooding downstream (to a total of 1.7 m acres).

Wilson et al (1977) have attempted to illustrate land use change in the Atlanta, Georgia region, using the technical method for detection of change over the period 1972 to 1974. Unfortunately, the authors concluded, this was not a satisfactory method of creating a data set relating to change in the environment as the noise levels (see above) were too great. Thus it seems that if a researcher wishes to use Landsat imagery for the detection of change, there is little substitute for manual interpretation at present, although considerable effort is being expended in devising improved methods of automated pixel classification.

Although Landsat imagery has been used primarily as a source of qualitative data relating to change, an attempt to collect quantitative data has been carried out, but with limited success. Frosh (1977) describes a method used to measure inter-censal population values for an area covering Western Illinois and South Eastern Iowa. Tobler (1969) has shown the population of a town

to be highly correlated with its areal extent and also, to a lesser degree, with the number of links to other urban areas, to the urban area of the nearest neighbour and the distance between the two of these. These variables can all be determined from satellite imagery (although in his case Skylab not Landsat was used) and, in theory, the population of the town calculated. This should be a relatively cheap and easy way of determining inter-censal population fluctuations. What actually emerged in Frosh's study was a substantial over or underestimation in many cases; the method was not up to a standard acceptable to the Bureau of the Census.

#### 3.2.4 Non-areal archives

Non-areal archives tend to provide a better source of time series data than do areal ones. Now they are often gathered together and placed in a computer-based data bank or geographic information system, and each record may well consist of a location identifier attached to thematic numeric data. Far from being 'random data collections' (Rose, 1974) data banks are 'highly efficient systems for storing information' (Taylor, 1978), relying heavily on the widespread availability of computer technology. Often formed as by-products of academic research (notably the Inter University Consortium for Political Research (IUCPR) at the University of Michigan, and the considerably

smaller SSRC Survey Archive at the University of Essex) they can play an important part in time series studies. For, as Bisco (1970) notes,

‘Very few data gathering activities involved ... time series methods. Currently researchers needing trend data must rely on archives to provide a set of comparable but different data collections because there are few ... studies in other data collections highly integrated over time’.

Data archives are then very important to the researcher seeking to develop time series data sets. There are a number of reasons for this, all linked to the four basic functions of the archives themselves - data collection, storage, manipulation and dissemination.

Data acquisition is the first function of any archive, such that data may be stored and disseminated in the future. The acquisition of a data set is normally determined by criteria such as the amount of overlap with an existing data set, the costs involved in cleaning and storage, and the ephemeral qualities of the data set, especially if it forms part of an existing time series within the archive (Nasatir, 1973). The existence of an archive may stimulate the production of data by researchers in a more regular and reliable fashion, extending the possibilities of exploring trends over time, either by direct financing or by the encouragement of deposition of updated data sets by researchers. Some evidence exists that this has already occurred in Britain, not least because the SSRC now make it a condition of any of their research grants that data produced in the research are

offered to the Survey Archive for making available to bona fide researchers. By specifying criteria for collection, sampling and coding, an archive can ease the construction of time series data sets by combining data sets based on these specifications.

A major function of a data archive is for storage of data. As well as coding and checking all incoming data for internal discrepancies, the archive should obtain the relevant documentation, and also handle the very mundane but necessary problems of physical data maintenance - to avoid deterioration of materials, create back-up copies of tapes, etc.

Manipulation of data is, in principle, probably the most important function of a data archive, especially with regard to the researcher seeking time series data. Retrieval of whole studies, parts of a study, or the combination of parts of several studies to create multi-file data sets relating to a given theme, event or location is an obligatory function, enabling a researcher to satisfy all his data needs at once by making use of the archive. Furthermore, the resources available at an archive are often (but not always) greater than those at the user's institution. Thus the archive may be in a better position to manipulate the data, extract smaller data sets and perform routine statistical tests especially if no local expertise is available.

Dissemination of information to users is the remaining function of an archive. As well as the distribution of data, the archive must make the researcher aware of its holdings. An

inventory of studies is normally maintained (e.g., Survey Archive, n.d.) and made available to users, preferably along with information on data sets held by other archives. The depth to which an archive should catalogue is questionable (and also dependent on the size of the archive) - it can be argued that the burden of searching should rest with the user. However, if he is seeking several data sets to build up a time series, then this can be a considerable task. Examples of time series data stored in archives may be found in the SSRC Survey Archive, and listed in their data catalogue (Survey Archive, n.d.). Amongst their holdings are listed data sets such as that pertaining to UK counties: data are available for the period 1851 to 1966 and covers such items as population, the birth rate, employment and religious composition. Ironically, their holdings related to foreign time series data seem somewhat larger; included are examples such as social, demographic and educational data for France, 1801 - 1897, time series data for Chicago, 1840 - 1973, Norwegian ecological data, 1868 - 1903 and 1949 - 1961, and Canadian census and election data, 1908 - 1968.

It must not be assumed from the above account that non-areal archive data are only available from computer-based data banks: although these will gradually increase in importance (due to their ability to supply data in machine-readable form, so no further coding is necessary prior to analysis), non-areal archive data are available from a wide range of other sources. Chief of these are government departments and organizations, from which

large volumes of data emanate as a result of the bureaucratic process. Many of these are one-off time slices<sup>of</sup> data rather than forming a time series, but table 3.1 shows selected British government data sources which could be used in a time series. The reader is also referred to Mitchell and Deane (1962), and Mitchell and Jones (1971), who have brought together data from many sources to present in time series. Impressive as the longevity of some of these series are, there is however a major problem in that many refer only to a national level (England, Wales, etc.). Clearly, maps can only be produced if data sources provide areal diversification - no matter how complete a time series, a map of just four areas is of little interest!

Perhaps the most widely used form of non-areal archive data in any country is the Census of Population. In most developed countries of the world a census is held at a regular time interval (for instance, in the USA and Great Britain, decennially, and in Sweden, Canada and Japan, quinquennially), thus constituting a reasonable time series source of socio-economic data and providing a succession of figures so that trends can be established (Robertson, 1969). There are, however, as with any data source, a number of problems associated with its use, especially if attempting the analysis of processes by using census data at a large scale. These problems will be outlined later in the chapter, but worthy of note here is the fact that censuses are based on areal units not necessarily related to meaningful or precise spatial units and are liable to change.

Table 3.1: Some official sources of time series data.

<u>Title</u>	(1) <u>Coverage</u>	(2) <u>Frequency</u>	(3) <u>Date</u>
Agricultural Statistics	GB	A	1939 - p.d.
Annual Abstract of Statistics	GB	A	1935 - p.d.
Annual Report of the Registrar General	RC	A	1839 - 1918
Annual Report of the Registrar General for Scotland	PLGA	A	1855 - p.d.
Annual Statement of Overseas Trade	UK	A	1906 - p.d.
Census of Production	GB	I	1907 - 1970
Criminal Statistics	GB	A	1970 - p.d.
Economic Trends	GB	A	1906 - p.d.
Financial Statistics	UK	M	1953 - p.d.
Labour Gazette	UK	M	1962 - p.d.
Monthly Digest of Statistics	UK	M	1893 - p.d.
Registrar General's Statistical Review	UK	M	1946 - p.d.
Statistical Abstract	PLGA	A	1922 - 1973
Statistical Abstract	UK	A	1852 - 1938

Footnotes:

1) Denotes general level of coverage: some tables may be given in greater detail.

GB: figures for England Scotland and Wales given separately.

UK: one figure for the whole of the UK only.

RC: registration county.

PLGA: principle local government areas - counties and CBs, some MBs in England and Wales pre-1974, counties and districts afterwards. In Scotland, counties and LBs, some SBs pre-1975, regions and some districts afterwards.

2) A = Annual, I = Irregular, M = Monthly.

3) p.d. = present date.

Source: Material in Newcastle University Library.

This can result in a large amount of data manipulation necessary before this problem is overcome, if indeed it can be at all. Perhaps the only country in the world where boundary changes do not constitute a great problem is the USA, where the boundaries of census tracts used for enumeration purposes (approximately equal to the British ward) remain very substantially unchanged through time and, at any other level in the administrative hierarchy, the adjustments needed to compensate for boundary changes are extremely small (McEvedy and Jones, 1978).

### 3.3 PROBLEMS OF TIME SERIES DATA COLLECTION

There are two reasons why there are few sources of time series data. First, few data are collected as complete time series, and secondly, 'time slice' data sets cannot readily be built to time series with any level of success as the attributes of the data sets themselves (see inside the framework of figure 3.1) do not match. As noted in section 3.1, the methods of data collection may also not match, but this is generally a lesser problem: data with similar attributes are often used in time series even if the method of data collection is different. That the method of data collection will change through time is often a function of increasing technology - for instance, the case of the census where a biological means of recording (man) has given way to mechanical (punched cards) and in turn to electronic (the

computer). This in itself does not prevent the data being used in time series: what does are the differing attributes of the resultant data sets. Some ways in which these attributes may differ are now considered.

### 3.3.1 Spatial attributes

A unique characteristic of any data set within a geographical information system is that it includes an explicit location identifier, which dictates its place within a time-space matrix of data relating to the environment. This location identifier may represent any one of three areal bases, namely points, lines or areas of zero, one or two dimensions respectively (Cox and Rhind, 1978).

Point data are of two kinds: data may be related to discretely distributed phenomena (e.g., output of mines, shipping tonnage from a port over time) or to phenomena with a truly continuous distribution, i.e., sampling of such distributions at pre-determined locations, such as continuous temperature recording. Line data can be divided into two types, namely static (structural) and dynamic (flow). Static line data, as the name suggests, are rarely encountered in time series, relating for example to the routes of roads and railways. Dynamic line data describe movement along a line between two points, observations on traffic flows belong to this class. Data relating to an area

are perhaps the type most often encountered, and again consist of two types. Stock data are observations on typological or structural variables occupying areas, such as population, land use and vegetation. Flow data relate to the movement between two areas and the spatial interaction between them, for example migration and flows of goods and commodities. This type of data are most often used in geographical studies, collected on one of three types of unit.

a) Natural units.

'Spatially distributed phenomena may be ubiquitous (available everywhere over the surface of the earth) or localized, but ubiquitous phenomena are rare; areal variation - spatial differences in occurrence and density - is characteristic of almost all distributions in terrestrial space'. (1)

Units for data collection are often delineated along such lines of areal variation or breaks in the distribution. Areas so defined are generally termed natural units and will exhibit a maximum between-area heterogeneity and a minimum within-area heterogeneity for any one purpose with respect to the variable under study. The success of this method depends on the level of specification of the variables to be 'regionalised'; mapping at a smaller scale will require a more generalised level of specification unless within-area heterogeneity is to be increased. Storing data in a geographical information system on this basis in a series of planes lends greater flexibility to any

1 Abler, Adams and Gould, 1972.

mapping exercise: automated cartographic systems such as ODYSSEY offer an overlay feature, whereby, for instance, all areas of population greater than X lying below Y units of altitude and within Z distance from a river may be determined and drawn. If the researcher is interested in determining the actual areal change in location of phenomena, then the mapping of a series of such units over time will portray this effectively, as has been illustrated in the preceding section on satellite imagery. However, for statistical data processing, especially with regard to urban areas which are generally more dynamic than rural areas, such a basis for a collection system is more difficult to make operational - for instance, it is not general practice to collect data on car ownership on a basis of areas as defined by population density, as these themselves would change through time, hindering the establishment of time series data set for the comparison of vehicle ownership between dates one and two.

b) Administrative units.

Much statistical data collection, particularly in the developed areas of the world, is done on the basis of existing administrative units, as data are by-products of the administrative system and a consequence of legislation. Although this basis of data collection usually forms a hierarchical structure so data aggregation into larger units becomes easier, there are a number of problems associated with such a configuration, chiefly the difference in size and shape of such

units, and changes in boundaries through time.

Considering the first of these problems, Hagerstrand (1967) provides a good analogy: time is measured in regular units, be they seconds or decades, thus allowing relative location in this dimension to be determined. Measurement of phenomena over units such as a politician's term in office would be extremely futile and misleading, but location in space is often measured along such lines, manifesting itself in the irregular area. Aggregation of data over such areas often results in inhomogeneity with respect to any one variable distributed over the area, and much detail can be lost in the process of aggregation. Figure 3.3 illustrates this point: the greater the level of aggregation - district (figure 3.3.1) to county (figure 3.3.2) to region (figure 3.3.3) - the greater the loss of detail regarding population distribution. Furthermore, they may introduce severe bias into the data collection process, in the effect they have on scale. This was demonstrated by Dickinson (1957) in his study of commuting patterns in Holland. Data were abstracted from the census, in which a commuter is defined as someone who lives and works in different <sup>7</sup> gemeeten (local government areas). Thus the towns of Utrecht and Limburg both had an exceptionally high number of commuters amongst their workforce, due in the first case to the large number of gemeeten which make up Utrecht, and in the second case because the gemeeten of Limburg are very small. This then represents the problem of scale: as such this problem becomes apparent

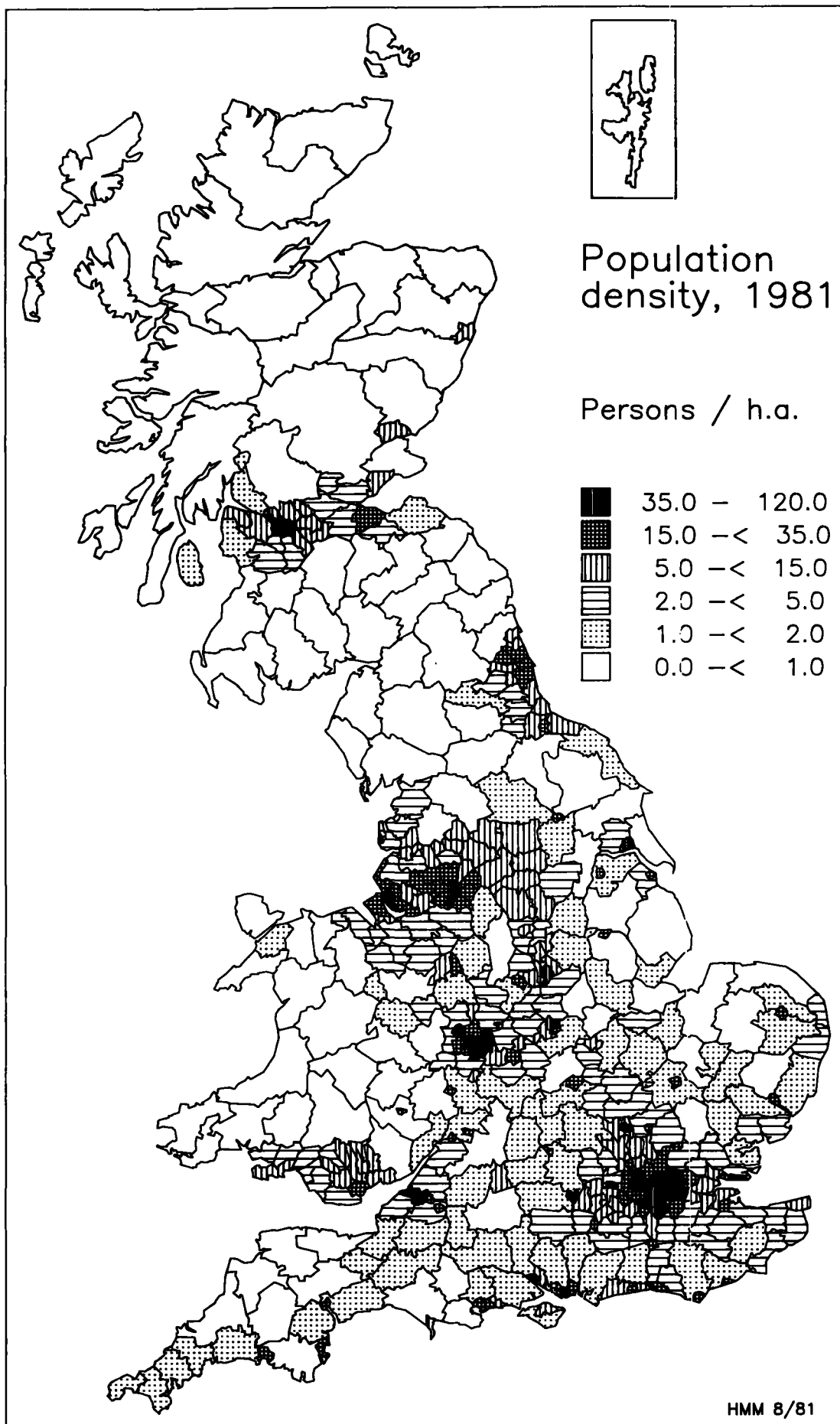

Figure 3.3.1

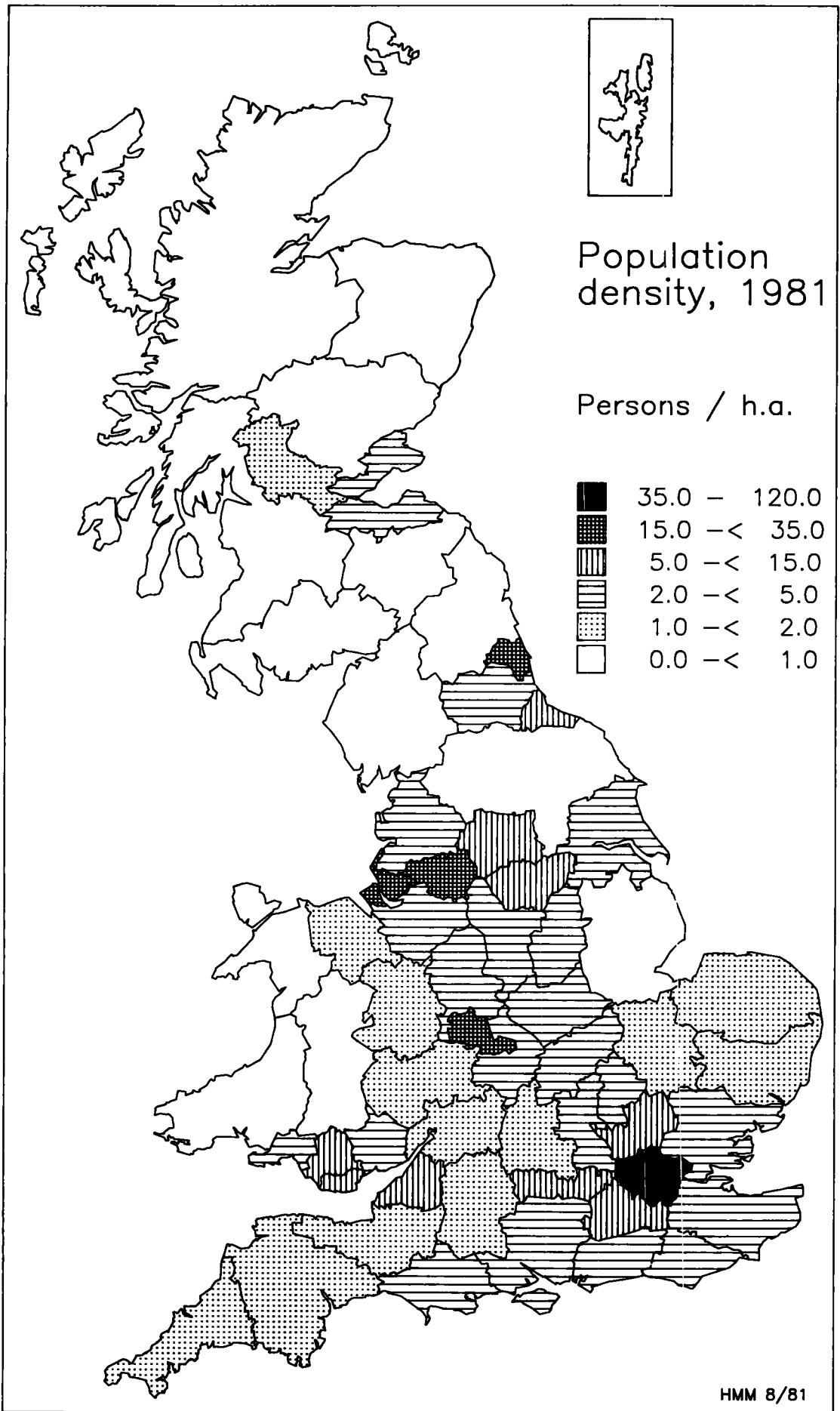

Figure 3.3.2

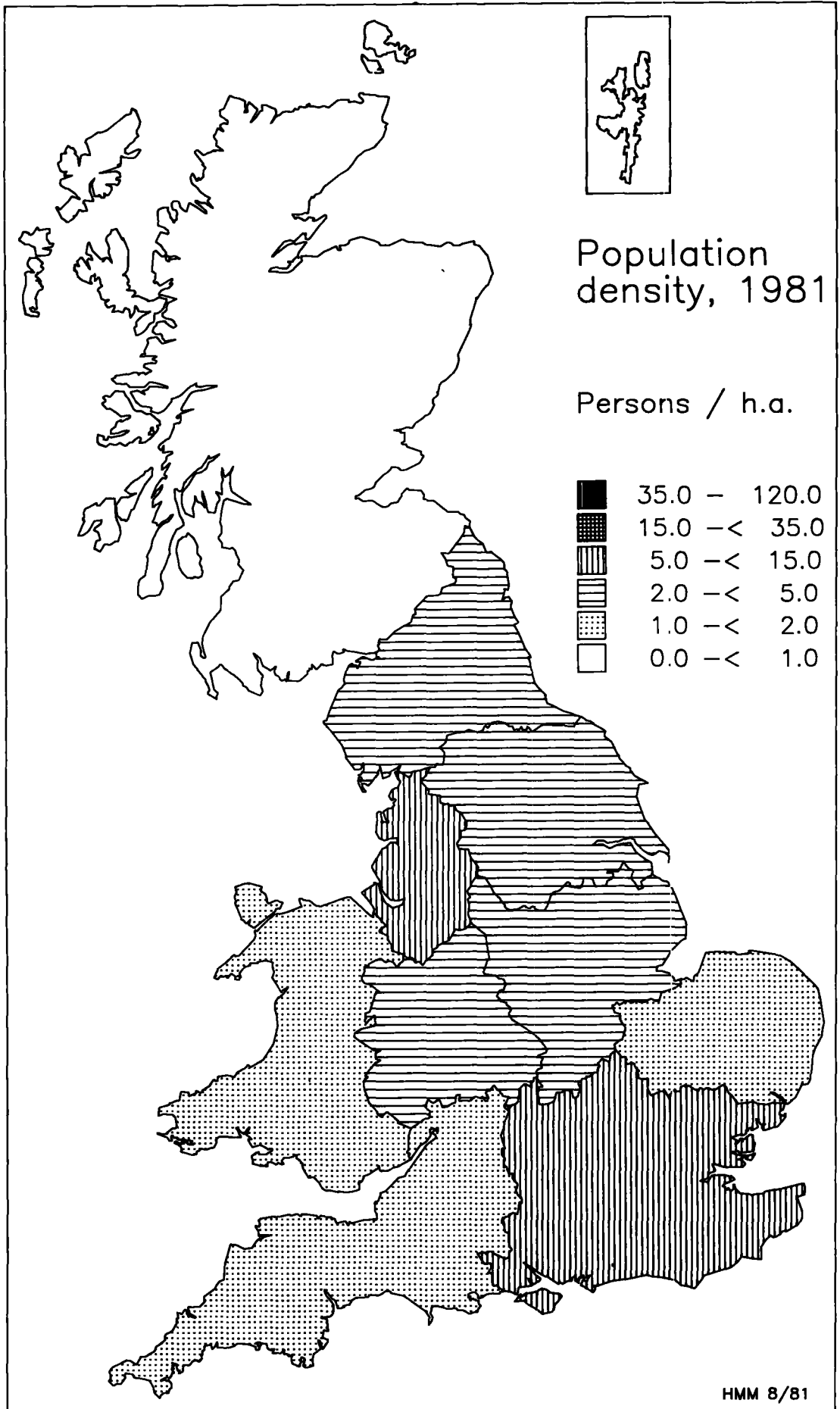

Figure 3.3.3

throughout the rest of this research.

Another problem related to the use of such areas is summarised by Lee (1971)

'As a general rule ... reliance on administrative or political boundaries should be reduced to a minimum, and where possible, completely eliminated, for they are notoriously volatile and subject to revision according to the changing requirements and responsibilities of the authorities responsible for the administration'.

Thus changes in boundaries obstruct the compilation of long running and accurate time series data sets, as was found in this research. (Changes in British administrative areas are considered further in the next chapter.)

As far back as 1870, Haviland (1870) recognised such problems posed by boundary changes, and went on to propose a solution to them.

'The registration districts of England and Wales were formed for the general purpose of Poor Law administration, and ... it could not be expected that they were planned with any view of assisting science ... it was generally believed among scientific men that if their boundaries were determined on a natural system the advantages to meteorology, climatology and other branches of science would be incalculable, and the expense and confusion of constant alterations avoided'.

Haviland went on to propose the adoption of the watershed as a basis for districts, a system used in the definition of the French Department. Thus

'we should have in every district a focus of scientific enquiry whether it be as to the rainfall, temperature, prevalence or strength of wind, agricultural statistics, the produce of our fields, our mines, or our rivers, or for the purpose of registering the occupations, the diseases, or the deaths of the people. Moreover such a

system would form the best basis map for every future census, and being a well considered and natural plan, would do away with the necessity of those eternal alterations which are now year by year going on, to the utter confusion of the scientific student".

Haviland was well aware that such a revolution could not be accomplished in under ten years, therefore he urged it to be commenced immediately and the results adopted for the 1881 census. In effect, the revolution took exactly 100 years and was transitory - the outcome was seen, not in the form of the watershed, but the grid square at the 1971 British census of population.

c) Arbitrary areal units.

The arbitrary unit, devised in response to some of the problems discussed above, has increasingly been adopted as a basis for data collection. The shape used is normally that of the square, the dimensions of which are determined by the characteristics of the phenomena under study.

The use of the arbitrary unit has many advantages, the principal of which is that it remains constant over time, so long as the co-ordinate system on which it is based does not change. Since this is usually the co-ordinate system used by the national mapping agency, or alternatively one based on latitude and longitude, this is an unlikely event. Furthermore, since all areas are of equal size, all counts automatically become densities, and are not affected by variations in area (unlike those based on administrative units). The use of squares is also

attractive in that data thus stored can easily be manipulated by standard computer techniques now widely available (see IGU, 1981).

However, there are also disadvantages encountered when using grid squares for data collection. It can create spurious accuracy or lose existing accuracy if the data are not initially collected on this basis (Rhind, 1978). Whatever scale is adopted, within-cell inhomogeneity will exist. If this is to be avoided or reduced to an acceptable level, a small meshed grid must be adopted. However, whilst necessary for urban areas (where despite this, features will invariably still cross nodes), this may be overly complex for rural areas; furthermore, vast quantities of data may result from this. Tomlinson (1972) argues a case for sizes ranging from 10 sq m in urban areas, down to 25 sq km in rural areas. The solution adopted for the first use of these units in Great Britain was the 1 km square based on the National Grid, although other user-selected sizes were available - some 100 m square data were produced. A further problem associated with the use of such collection units is that there is no direct recognition of spatial patterns. However, aggregation can always be used to derive irregular areas for mapping. It is also arguable that they do not relate to reality in that such units cannot be identified by physical features on the ground; thus they are unpopular with administrators.

A short term problem is that arbitrary units cannot readily be related to existing data. However, the 1971 census was

aggregated from questionnaire responses, both on a basis of administrative and arbitrary units, and, as Lee (1971) notes,

'The General Register Office has now accepted the principles of recording census information by grid squares, so that over time a bank of data will be built up on this basis'.

However, because the collection of grid square data is expensive, this is no longer true; grid square data will not be produced for all of Britain from the 1981 census. This is very unfortunate as, provided the thematic elements remained unchanged, it would have supplied the one means for building a valid time series data set to examine many forms of social and economic change from a future vantage point.

Collection of data on a grid system in 1971 in Britain was found to be very efficient - subsequent examination showed that in only 3% of all cases recorded were grid square references omitted, and only 2% required correction (Jones et al, 1973). Such a system then, if continued, would have offered better prospects for the development of a time series data collection relating to the British population and households than does the collection on the existing administrative unit basis. Despite extensive changes to this administrative area set in 1974 (see chapter 4), it can be assumed that major change will occur sometime in the future; indeed minor post-1974 changes have already occurred (see chapter 4). Thus the problems that Haviland noted in 1870 are still present, and, since a data bank is not now to be built up utilizing grid squares, they will

inevitably continue in future.

### 3.3.2 Temporal attributes

When obtaining a time series data set, be it from survey or archival sources, the temporal attributes are as important as the spatial attributes (although this is not usually the case for 'time slice' data) and equally great problems can arise. Figure 3.1 shows the three subdivisions of temporal attributes - temporal duration, temporal resolution and temporal frequency.

The first of these, temporal duration, relates to the time period over which the data are to be collected in order to illustrate the effect of processes at work. Often, especially when studying processes in 'human' geography, this is fairly long, measured in terms of decades rather than years and months, and a problem is simply finding a consistent data set spanning this time period. Data sets covering a shorter time span are sometimes available, and of good internal consistency, but invariably do not provide a sufficient degree of 'change' for animated cartography. Such a data set is that of the British mid-year estimates of population. The author attempted to use these, from a base year of 1971 through to 1979, as the data set exhibits a high level of internal consistency. However, the level of population growth over this time period was very low (a gain of some 266,000 people or 0.4% for Great Britain) and

although change in the distribution of the population did occur, it was too insignificant to be of use for animated filming. To avoid this, the period over which the data was collected had to be extended which, in turn, introduced severe problems relating to spatial attributes of the data.

The temporal resolution of the data set represents the period within the temporal duration over which data are to be aggregated - for instance, the number of births per year (the temporal resolution) over a period of ten years (the temporal duration). Too coarse a resolution can lead to loss of detail. Moreover, differing periods of aggregation throughout the temporal duration may introduce problems into the data collection process.

Related to the temporal resolution is the temporal frequency of the data set. This element determines the number of points at which a data set is sampled, within a defined time period. This is often too low to give an accurate picture of change; for instance, the population census, if used as a time series, completely missed the immediate effects of the First World War, which occurred during an inter-censal period. The time series may be irregular or may contain breaks (e.g., the abortive 1941 Census of Population): in these cases interpolation, backed where necessary by circumstantial evidence, must be used to fill the gaps.

### 3.3.3 Thematic attributes

A third element of any data set is the thematic aspect. In a genuine time series, this will remain constant through time, the same data being collected by the same methodology for the same variable. However, and especially if using archival data, the researcher often has to build his own time series and problems may well arise within this process.

An obvious problem is a simple lack of data sets covering the same topic which could be aggregated over time. More serious are subtle changes: although seemingly comparable data sets may exist to form into a time series, slight differences may render the results invalid. The units of measurement may change through time, affecting the precision of the data. The wording of questions or the sampling techniques may change, thus making the two data sets strictly non-comparable. If using derived variables, the method of derivation must be consistent, and convention relating to the combination of nominal, ordinal, interval and ratio data must be observed. Data available through time may have been aggregated to larger spatial units or only derived data may have been stored to reduce the amount of storage space necessary, but hindering disaggregation into smaller units for comparison with another survey.

Finally, irrespective of the quality of data available, certain technical considerations may pose problems in the creation of time series of data. This is particularly true of

small area census data. Copyright restrictions and requests for confidentiality may limit access to data sets. If more than one source has to be examined, time and money may act as limiting factors. Many data banks are now automated and problems may arise through differences in hardware which preclude the easy flow of data (for instance conversion of magnetic tape formats). Lastly, lack of care, or simple software errors may result in incomplete, unclean or unedited data being distributed to the user (some of which he may be unable to detect!).

Most problems involved in the building of time series data sets stem from an inability to relate data sets to each other. This would be easier if certain standards for data acquisition and storage were met, the minimum of which are defined by Tomlinson (1972) as being as follows:

1. Standard data definitions and terminology must be observed.
2. Standard units of measurement should be used.
3. Standards relating to the accuracy and reliability must be observed in that these affect the quality of the resulting data.
4. Standard data formats should be used to enable easy manipulation and comparison.

5. A strict periodicity of reporting should be used to ensure data sets are coincident, or sequential at regular intervals.
6. Standard classification systems should be used.
7. Standard coding systems should be used.

Strict observance of the above standards (which must be documented) would lead to many more useful time series. The standards themselves may change as data collection is an on-going process, subject to a large number of technological developments - increasing the accuracy of measurement, for example, is a very laudable process - but all changes must be backwards compatible otherwise the resultant data sets will be of as little use as many available at present not collected to the above requirements.

Ultimately, time series data sets may simply not exist. After examining methods of determining trends in time series data, Soot (1975) concludes

'The primary reason [for their lack of use] is the lack of reliable temporal data in constant geographic units to examine these trends. Aside from population figures, how many data sets span 100 years?'

Although in Britain a few data sets not relating to population (e.g., agricultural statistics) do span 100 years, population figures show the greatest consistency over such a period. Furthermore, they can show the effects of a wide range of

processes (migration, births and deaths) incorporated into just one measure, population density. It is for this reason, and for the relative ease of presenting such a variable cartographically, that the author chose to use population data in this research. It was decided to cover the whole country (but to exclude Northern Ireland and the Isle of Man) in order to incorporate as great a degree of change as possible and, consequently, the widest range of possible causes for this change. The data should also be on the currently relevant local authority boundaries (post 1974/5) for contemporaneity. Possible sources of data which meet such criteria are examined in the next section.

#### 3.4 SOURCES OF TIME SERIES POPULATION DATA

Data relating to the total population may emanate from any of the sources illustrated in figure 3.2 - survey, areal archives and non-areal archives. However, only non-areal archives generally produce good time series. Unless over a very small area, a total or sample survey of the population is impracticable for the individual researcher to undertake, usually requiring resources beyond his disposal. Whilst data relating to the total population can be abstracted from areal archives (see, for instance, section 3.2.3) it is often of a low level of accuracy, or often results from some kind of grouping or classification which was a part of the initial map making process.

Non-areal archives, on the other hand, can provide a reasonable source of time series population data. Four separate types can be distinguished: the Census of Population, the mid-year estimates of population, the Electoral Register and public utility and other official lists. The types of data available from each source are variable: not all provide age and sex breakdowns and the latter two, with regard to the total population, are often incomplete records. Each is now considered in an order reflecting general availability and ease of use.

#### 3.4.1 The Census of Population

Established in 1801 and held decennially since (with the exception of 1941), the British census provides a long running time series of total population figures (plus time series of other variables not considered here). With reference to figure 3.1, as a method of data collection it fulfils the requirements of the framework depicted there, at least for the latter part of its existence: procedures laid down by the Census Act of 1920 ensure an operationally definable process (from that date onwards), which is repeated nationwide. Furthermore, a high level of accuracy is maintained through time. Data are available in published volumes and also (since 1951) on microfilm and as computer output to printout, on cards or on magnetic tape. The researcher may have difficulty locating copies of the 19th

century censuses, but OPCS maintain complete sets freely available to the public for reference, and the early census volumes (1801 - 1891, including Scotland and Eire) have been reproduced in the Irish University Press series of facsimile reproductions of British Parliamentary papers, often available in specialist libraries (OPCS, 1980c).

As a source of population data, the census has advantages and disadvantages. There is no doubt that it represents the longest time series of population data available in this country. Consistency was maintained in the definition of 'total population' until 1971, and (disregarding the 1966 Sample Census) this variable has always been enumerated as a total count and not a sample, avoiding bias from that source. Thus it can be used as a reliable 'bench mark' representing the total population every ten years.

Disadvantages of the census are its low temporal frequency and the spatial identifier (see figure 3.1). A count every ten years loses much detail of change in the inter-censal period - for instance (and as noted earlier), the detailed effects of the entire First World War and consequent redistribution of the population up to 1921 passed unrecorded in this source.

Over a period of ten years, there is also much change in the areal basis. With the exception of the Scottish parish, small census taking areas are very unstable in boundary, and comparison over time becomes difficult. This problem is examined further in the next chapter.

Despite these problems, the census, being both widely available and long-running, forms a reasonable source of time series population data. It was used for this research and a detailed examination of the limitations follows in chapter 4.

### 3.4.2 The mid-year estimates

The mid-year estimates of the total population are now made annually by OPCS/GRO(S), and previously were made by the GRO. Such estimates were first made for county boroughs in 1911, along with those for urban and rural aggregates. In 1915, the population of all local authorities was estimated for the first time. Thus, like the census, they form a long running time series of data.

Unfortunately, unlike the census, up to 1976 they were not made using a similar method of estimation for any two successive years (OPCS, 1980d). The method of estimation employs several different sources of data and, as these have improved in quality and consistency, so slight changes in the methodology have occurred annually. This, then, does not meet the requirements of the framework in figure 3.1 - although the methodology is consistent through space, this is not the case through time. Furthermore, compounded errors in the mid-year estimates can be quite large (see section 4.2.1). Like the census, the mid-year estimates are based on the areal pattern of local government

units in force at the time; changes in these also ensure a lack of comparability through the time series.

In 1976, OPCS recalibrated the mid-year estimates back to 1971, in the light of errors revealed within them by the 1971 census. Moreover, they were reaggregated to the new post-1974 local government areas. Since 1976, all further mid-year estimates have been made using the same methodology. Thus a short-run data set meeting the requirements of the external framework (see figure 3.1), and on a consistent areal basis is available. Together with census data this was used for the research in hand, and is examined in greater detail in chapter 4.

#### 3.4.3 The Electoral Register

Under the Representation of the People Acts, a householder is required (although not legally enforced) to make an annual return to the Registration Officer of his district giving a list of all members of his household over the age of 16, in order that they may receive a vote in local and parliamentary elections. As the householder's address is also included, the returns can be aggregated to any level, ward level being that normally used. This procedure can therefore give rise to a source of population data; indeed Short (1978) has used this to analyse change in the population of the Bristol region, and some local authorities use it as a basis to produce their own annual population estimates

independent of those done by OPCS.

The advantages of use of the Electoral Register for production of population data are many (OPCS, 1980b). It is based on a canvass of every household on the country, and (of great advantage to those seeking time series data), it is constructed every year. Finally it can, in principle, be aggregated to any pattern of areal units (it is not confidential at this micro-level), and the main problem encountered in the use of the census and the mid-year estimates (that of changes in boundary) does not arise.

A severe disadvantage which arises from use of the present system of electoral registration is that it only contains an estimated 70% of the total population nationally (OPCS, 1980b) and thus the problem of finding a correct multiplication factor to bring this level to 100% arises (a factor which varies greatly on a local basis). Allied to the fact that there are 'undesirably variable standards' (Menner, 1976) in coverage from area to area, it would appear that the Electoral Register as a source of population data comes nowhere near meeting the requirements of the framework in figure 3.1. Not only are those under the age of 16 and all foreign nationals resident here omitted, but it is also legally possible to be on more than one register (multiple home-owners and students for example). Furthermore, for fear of disenfranchising someone, there is a tendency not to remove those now dead or no longer resident in the area. The British Market Research Bureau in the spring of

1976 conducted a survey in one London borough to discover the extent of anomalies in the register, and were 'surprised' by the number on the register who had in fact been deceased for several years (Menneer, 1976). It seems likely that there is much areal variation in such anomalies.

As a country-wide source of population data, the Electoral Register as it stands at present is thus of dubious value, and was not used by the author in her research. It is perhaps of limited use in small area studies, but the need for aggregation of its contents to some areal base, and the limited availability of them to researchers elsewhere in the country, restricts its use. It is worth noting that between January 1976 and May 1979, Parliament (via a steering committee under an OPCS chairman) examined the feasibility of extending the Electoral Register to represent a total coverage of the population, and include the age and possibly marital status of all those present in the UK on registration night regardless of eligibility to vote at elections. Some improvement in the accuracy of the canvass would also be required. Such a proposal was in fact tested in Shropshire in 1976, with acceptable results (Masters and Shortridge, 1981). However, a further test in Nottingham proved such a system to be of more limited use in urban areas (Brazier and Hayward, 1981).

The proposal to increase the coverage was eventually turned down by the government in June, 1980 on a number of grounds. It was stated that many local authorities would not be willing to

spend extra money on improving the quality of coverage; there is no way of excluding multiple registrations; it is difficult to reconcile the traditional independence of Electoral Registration Officers with central control needed to ensure countrywide standards; and, finally, only a small number of objectors would be needed to generate suspicions within the general public of an invasion of privacy, which in turn would hamper the present smooth running of the electoral system (OPCS, 1980b). When viewed in the light of the notable lack of time series population data in Britain, such a decision (like the virtual abandonment of grid squares as areal units in the 1981 Census) is regrettable.

#### 3.4.4 Public utility and other official lists

As a by-product of many bureaucratic processes, lists of population or households in any one area can be produced. These include health records (the NHSCR), education records (the DES rolls of schoolchildren and local authority records of students in higher education), and public utility lists (the water and electricity boards, gas council, the Post Office etc.). These can give rise to a certain amount of data pertaining to the population of an area. However, even if studying a very small area, a large number of problems arise from the use of such sources. Chief of these are the disparity of areas to which the records relate, certain issues of confidentiality, coverage of

only certain cohorts of the population or (if using household lists) the necessity of making assumptions relating to average household size. Inaccuracies introduced through them may be substantial; as shown in chapter 4, the inclusion of data from the Housing Development Register into the methodology used in constructing the OPCS mid-year estimates was held responsible for almost all the discrepancies found between those of 1971 and the 1971 census; its use as a data source was later discontinued for this reason. In this study, it would be totally impracticable to try to assimilate any such sources into the construction of a time series population data set covering the entire country, and a period over which meaningful change has occurred.

Disregarding the last two sources then, the author hoped to use census and mid-year estimate population data for the period 1901 to 1979 for studies relating to population change. The data were to cover the whole country, at the post-1974 district level. Despite the fact that both the census and the mid-year estimates (new series) from 1971 onwards both meet the requirements of the framework of figure 3.1, the author encountered a number of problems in using these two sources, related to the characteristics of the data themselves (see within the framework of figure 3.1). Attempts to use the two sources, problems encountered, and their solution resulting in a population data set covering the period 1901 to 1979, are described in the following chapter.

#### 4 THE CREATION OF A POPULATION TIME SERIES DATA SET

As noted in the previous chapter, the problems of finding a suitable time series data set for computer-animated mapping are very considerable. Many of those already available are either not long or consistent enough; as Soot concludes (see section 3.3.3) only population data sets may provide even a partial solution. Certainly, in relation to Great Britain, it seems that use of the Census of Population or of the mid-year estimates is appropriate. Each of these is examined in turn.

##### 4.1 THE CENSUS OF POPULATION

The continuity of the census of population as a source of demographic data is impressive (Benjamin, 1970) and, although the contents have shown considerable variation over time, a recording of the total population has always been its primary aim (Dickinson, 1973). In view of this, it would seem to provide a very good time series data set for studying change in the distribution of the population.

However, despite having both continuity and longevity in its favour, there are a number of factors acting against the direct use of census data for a study of population change. One is the temporal frequency. Whilst the temporal duration is great (some 180 years to date), and the temporal resolution is also good (one

night), the temporal frequency is very poor (every 10 years). However, the greatest problem, and one which most disrupts the formation of a time series, is that of boundary changes in the data collection areas. It is often believed that the pre-1974 local government areas were all established by 1900, and thus the formation of a time series of data should not pose this type of problem. However, over the time period from 1901 to 1971, a number of more minor alterations in boundary have occurred, the sum totals of which in some areas are greater than those occurring during the major reorganisation in 1974. The causes of these changes, which result in comparisons of successive data sets being difficult and sometimes impossible, are examined below.

#### 4.1.1 Development of local government areas in England and Wales

The availability of census data by anything other than local government areas is a recent innovation - 1961 for Enumeration Districts, and 1951 for microdata in the form of the pre-1851 enumerators' handbooks released under the 100 year rule. Thus local government areas are the only ones from which long time series may be assembled. However, they have changed greatly through time, both in England and Wales and in Scotland, despite widely differing bases of local government in these countries.

In England and Wales, the first census of 1801 was presented upon an areal basis of ancient counties, sub-divided to urban boroughs and rural hundreds (see figure 4.1); the origins of these ancient counties can be traced back to the Saxon period (COI, 1972). By the early 1830s, severe corruption had become rife throughout the system, and the first electoral reform act (the abolition of Rotten Boroughs) was passed in 1832.

The origins of the 20th century system of local government can be traced back to 1835, with the passing of the second bill of reform, the Municipal Corporations Act. This Act established the 173 largest towns outside London as chartered boroughs, replacing the ruling 'self perpetuating oligarchies of freemen' (Jackson, 1976) with self-elected councils. Further reform at this level occurred with the passing of the Local Government Act of 1888, when those boroughs with a population of over 50,000 were allowed to adopt the newly defined status of county borough, being independent of the surrounding county, and having the same powers as the latter within their boundaries. Smaller towns below this population limit were designated municipal boroughs, being under the jurisdiction of their parent county. Thus by 1888, the status of county and municipal boroughs had been established, and was to remain as such (except for increases in the qualifying population limit in stages to 100,000) until 1974.

Extra-burghal population was initially divided to hundreds, and subdivided to ancient parishes. A succession of Poor Law and Public Health Acts throughout the 19th century saw, by 1872, the

Figure 4.1: Development of Local Government Areas in England and Wales.

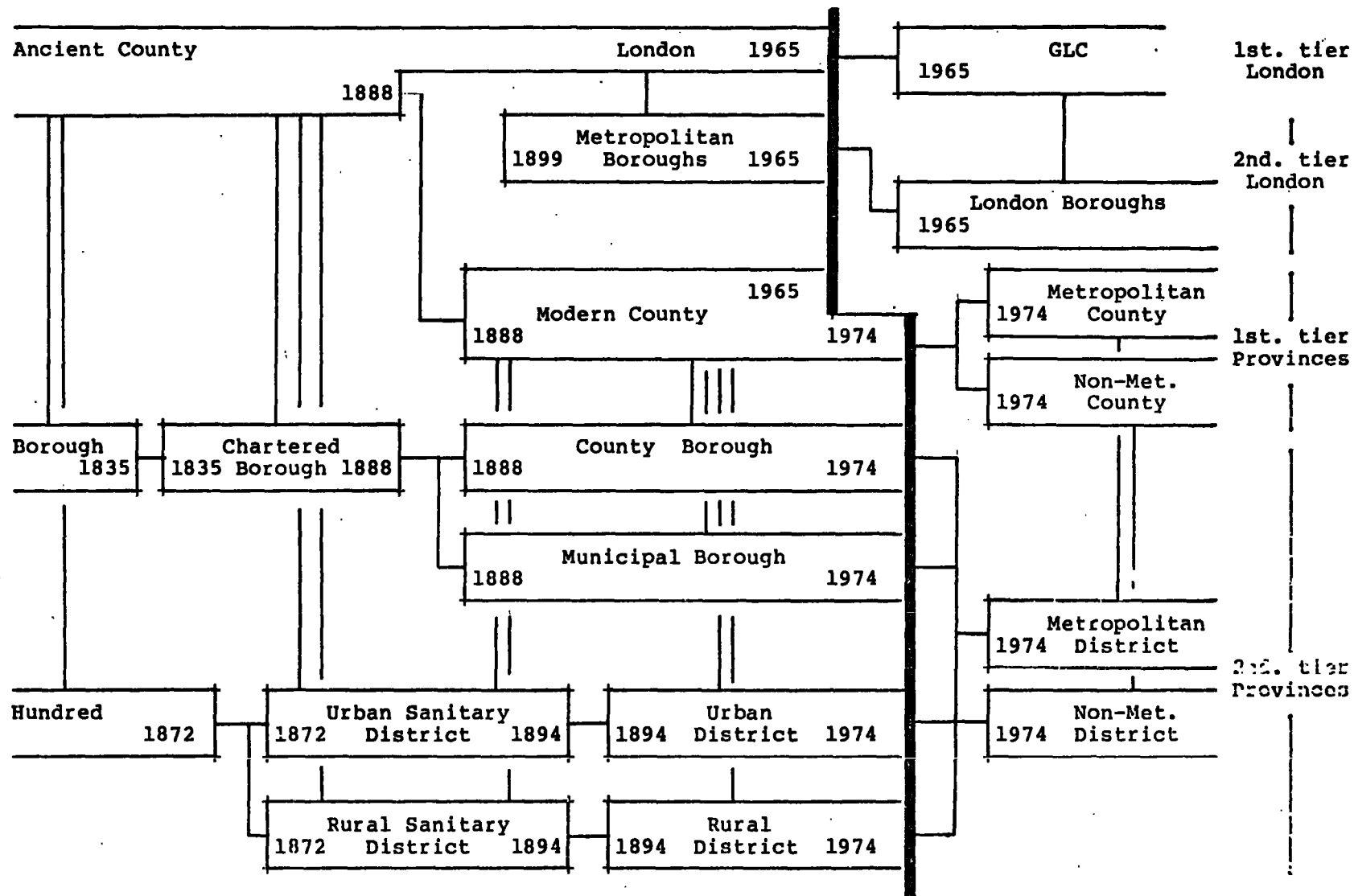

— = major reform

In all areas the parish forms a third tier.

Source: Compiled from basic data.

definition of urban and rural sanitary districts, the former governed by elected councils, and the latter ruled by the self-appointed Poor Law Guardians. Despite this apparent reform, Redlich and Hurst (1970) have described local government of the 1880s as a 'puzzle of conflicting and intersecting areas'; together with increasing pressure for self-government of rural areas, this led to the Local Government Act of 1894, the last major reform in this field of the 19th century outside London. Under this Act, the sanitary districts were reorganised to urban and rural districts, each with a self-elected council. Thus, by 1900, a local government system had been established whose structure was not to alter fundamentally until 1974.

The pattern of local government areas in the (pre-1963) county of London had also been established by 1900. However, their establishment had followed a pattern different to that of the provinces. In 1801, the population of the City of London was still under one million, with Kensington, Richmond and others still forming distinct outlying towns. Despite rapid urban development, and unprecedented population growth rates (for instance, in the Metropolitan Borough of Paddington, where the population rose from 2,178 in 1801 to 29,123 in 1841 and to 135,955 in 1901), the 1835 Act left London untouched and, by 1850, there was no overall government spanning the ever-increasing area. The Metropolitan Board of Works was established in 1855 only to be replaced by the London County Council in 1880, elected by the 127 constituent vestries. The

1899 London Government Act then reorganised these latter into 28 metropolitan boroughs, completing the 19th century electoral reform and establishing a system which was not to change until the early 1960s.

There is thus much apparent stability in local government areas throughout the 20th century; despite this, many smaller changes in boundaries have taken place, the sum of which form an immense obstacle to the creation of a time series of population data based on the census. After the major reforms of the 1880s and 90s, the first 30 years of the 20th century show relatively few boundary changes, with major ones only occurring as a result of the suburban expansion of London and of consolidation within the increasingly industrial areas of Staffordshire, Warwickshire and West Yorkshire (see table 4.1).

The first local government act of this century was passed in 1929, with widespread effects. Although its primary aim was to remove a relic of the 19th century, the Poor Law Guardians, another clause required County Councils to undertake reviews of their internal district boundaries every ten years, and to submit reorganisation plans (if any) to the relevant Minister. This resulted in extensive piecemeal reorganisation throughout the 1930s as each county submitted its review plans. The resulting County Review Orders had such devastating effects on the boundaries used for census enumeration (see table 4.1, boundary changes for the period 1931 to 1935) that the direct comparison of 1931 and 1951 data is impossible in all but a very few areas.

Table 4.1: Boundary changes in England and Wales.

	a	b	c	d	e	f	g	h	i
Bedfordshire	12	10	2	6	0	0	9	2	0
Berkshire	19	14	5	1	0	0	5	1	2
Buckinghamshire	19	17	2	0	0	0	13	4	2
Cambridgeshire & Isle of Ely	12	6	6	0	0	0	10	1	1
Cheshire	46	43	3	1	3	1	47	4	2
Cornwall	28	21	7	6	0	0	44	1	1
Cumberland	14	11	3	0	0	1	21	0	1
Derbyshire	30	28	2	3	0	4	30	4	3
Devon	43	25	18	11	1	1	12	1	2
Dorset	21	16	5	0	1	0	10	4	0
Durham	36	6	30	8	0	1	43	6	2
Essex	35	29	6	(13)0	2	0	38	7	3
Gloucestershire	25	20	5	3	0	3	33	4	0
GLC	33	33	0	0	0	0	27	15	6
Hampshire	29	28	1	0	4	0	44	5	5
Hereford	12	7	5	2	0	0	3	5	0
Hertfordshire	33	27	6	(2)2	2	0	29	1	7
Huntingdon & Peterborough	13	8	5	1	0	0	7	1	0
Kent	47	34	13	(8)4	0	1	30	5	2
Lancashire	125	53	72	1	20	3	37	9	8
Leicestershire	20	16	4	3	0	0	21	2	2
Lincs, Holland	5	5	0	0	0	0	7	0	0
Lincs, Kesteven	22	13	9	0	2	0	0	12	0
Lincs, Lindsey	22	13	9	0	2	0	0	12	0
Norfolk	29	18	11	1	1	2	21	2	0
Northamptonshire	22	15	7	3	0	1	20	1	0
Northumberland	28	16	12	0	0	0	18	0	5
Nottinghamshire	21	14	7	0	1	0	18	1	0
Oxfordshire	14	10	4	0	0	1	17	2	0
Rutland	4	0	4	0	0	0	0	0	0
Shropshire	14	13	1	23	0	0	21	0	0
Somerset	37	26	11	1	2	4	18	3	4
Staffordshire	28	26	2	34	1	0	35	13	1
Suffolk, East	20	13	7	0	3	0	19	0	1
Suffolk, West	11	5	6	0	0	0	8	0	0
Surrey	23	21	2	(13)3	1	0	34	9	8
Sussex, East	18	17	1	0	2	2	20	5	0
Sussex, West	15	10	5	0	2	0	13	2	0
Warwickshire	19	15	4	9	0	0	20	13	5
Westmorland	6	5	1	0	0	0	11	0	1
Isle of Wight	6	6	0	0	0	0	9	1	0
Wiltshire	25	19	6	0	2	0	20	3	2
Worcestershire	20	20	0	5	1	0	28	9	7

con't . . .

Table 4.1 continued.

Yorkshire E.R.	18	15	3	3	0	0	25	4	1
Yorkshire N.R.	32	15	17	9	1	0	16	0	0
Yorkshire W.R.	100	64	36	4	1	0	115	13	15
Anglesey	8	1	7	0	0	0	1	0	0
Breconshire	11	2	9	0	0	0	2	0	0
Cardiganshire	9	3	6	0	0	0	4	0	1
Carmarthenshire	13	4	9	0	0	0	5	0	2
Carnaervonshire	15	7	8	0	0	0	8	2	0
Denbighshire	12	9	3	0	0	0	15	1	0
Flint	11	8	3	0	0	0	6	3	0
Glamorgan	27	8	19	1	0	1	2	6	3
Merionethshire	9	5	4	0	1	0	4	1	0
Monmouthshire	24	13	11	2	1	0	14	0	1
Montgomeryshire	10	0	10	0	0	0	0	0	0
Pembrokeshire	11	5	6	0	1	0	8	1	0
Radnorshire	8	0	8	0	0	0	0	0	0
<b>Total</b>	<b>1366</b>	<b>904</b>	<b>462</b>	<b>187</b>	<b>46</b>	<b>26</b>	<b>1101</b>	<b>195</b>	<b>116</b>

Total number of boundary changes = 1670

- a = Total number of local government areas.
- b = Total number of changed areas.
- c = Total number of unchanged areas.
- d = Number of boundary changes: 1961 - 1971
- e = 1951 - 1961
- f = 1935 - 1951
- g = 1931 - 1935
- h = 1921 - 1931
- i = 1911 - 1921

Source: See Appendix C.

Notes: 1) Figures in parenthesis for Essex, Kent, Herts., and Surrey indicate number of areas lost to the GLC in 1966. Changes in the boundaries of these areas constitute those listed for the GLC and are not included in each individual county.

2) A change is defined in this case as a gain by one area of another (or part thereof). Thus the one change in Anglesey is an amalgamation of two areas.

To alleviate this problem, the General Register Office reaggregated the 1931 census in part, together with some of the 1921 census, and republished the results on the revised areal basis to facilitate comparison. The general pattern during this period of review was one of consolidation; urban districts were reduced in number by 255, and rural districts by 169. The most severely affected county was that of West Yorkshire, where 70 areas were abolished or split, reducing the number of constituent authorities from 158 to 100 (eleven new ones being created, the remainder being merged).

The Second World War produced an end to this county-by-county reorganisation and, in January 1945, a Local Government Boundary Commission was established to carry out an overall review of England and Wales. Despite producing some radical suggestions for a widespread reorganisation, the Commission disbanded itself in 1948, due to lack of further action at Parliamentary level.

The 1950s then saw very few changes in boundary. Claims by the larger municipal boroughs for county borough status (and therefore independence from their parent counties) were all held in abeyance, none being created between 1926 and 1964. Serious anomalies existed; Luton remained a municipal borough, with a population (in 1951) of over 113,000, whereas Burton on Trent held county borough status, with a population of about 49,000 in 1951. This is unfortunate, since some census data are presented for counties and county boroughs, and not for municipal boroughs (see Norris and Mounsey, 1982). At the other end of the scale,

the 1951 Census records of Nottingham Town Hall state:

'The exact status of this area is uncertain and it does not form part of any county district'

and, of York Castle:

'This area is treated as part of the city for census purposes although its exact status is uncertain.'

These represent just two of a number of remaining 19th century extra-parochial places, others of which include the Eddystone lighthouse, Plymouth breakwater and Lundy Island (although almost all are insignificant in terms of national or regional level mapping). As a result of growing dissatisfaction over the areal basis of local government, the Local Government Act of 1953 was passed through Parliament, establishing a Local Government Commission for England and Wales to review areas and to recommend alterations of boundaries. Nine separate reports for England were published, together with one for Wales, and although some of their suggestions were not acted upon, and some reports published after the establishment of the Royal Commission on Local Government in England in 1966 (and therefore not considered further), the 1960s saw the most extensive alterations in boundaries since the 1930s. The most notable of these are reflected in table 4.1; expansion of the West Midlands towns into Staffordshire, Warwickshire and Shropshire, and the creation of Torbay County Borough in Devon, and Teesside County Borough, which affected both Durham and North Yorkshire. As a result of the East Midlands report, the first alterations of county

boundaries took place since the establishment of the county boroughs in 1888, these being the amalgamation of Cambridge and the Isle of Ely, and of Huntingdon and the Soke of Peterborough.

Although these changes in boundary all render the formation of time series data from the census difficult, even those of the 1930s cannot be described as major structural reform. The last such reform had taken place in 1899 with the creation of the metropolitan boroughs, and it was again in London that the first major reform of the 20th century took place. Massive suburban expansion during this century and a decline in the population of Inner London led to the engulfment of the (independent) county of Middlesex and of parts of Hertfordshire, Surrey, Kent and Essex. By 1950, this area of approximately 1,864 sq km and over 8m people was administered by 95 authorities (Morrey, 1973). Furthermore, anachronisms such as a rural district in Middlesex continued to exist. The problem was examined at length throughout the decade of 1940, but it was not until 1957 that a Royal Commission on Greater London was established. In issuing a unanimous report in 1960, they recommended a total reform in local government in the Greater London area, recording

“the fact that local government in London does manage to hang together and avoid a breakdown says much for the British knack of making the most cumbrous machinery somehow work”. (1)

Understandably, several authorities faced with extinction (including Middlesex County Council) raised objection to the

---

1 Herbert, 1960.

proposed much enlarged Greater London Council with 52 constituent London boroughs (encompassing parts of Essex, Kent, Surrey and Hertfordshire), and some two years passed in their investigation. The final pattern of 32 London boroughs (and the unaltered City of London, which is totally independent and has not been classified under any system thus far) was drawn up by the Town Clerks of Cheltenham, Oxford, Plymouth and South Shields. The passage of the bill through Parliament was slow, but finally reached the Statute book in January 1963; the reorganisation took place in April, 1965.

During the 1960s, then, the areal basis of provincial government was still, to a large extent, that in existence at the turn of the century. Massive population increase since that date, combined with the decline of agriculture as the major employer, led to a huge urban expansion - in some cases rendering the distinction between urban and rural districts meaningless. Furthermore, as in the London area, areas which were essentially one economic unit were administered by numerous local authorities. Piecemeal expansion of urban areas (which represent almost all the boundary changes in table 4.1) had to some extent redressed the balance, helped by alterations following the reports of the Local Government Commission of 1958. However, the major problem was the large number of areas - 1,366 in England and Wales - and their vast disparity in population size (see table 4.2).

**Table 4.2: Population of pre-1974 local government areas  
in England and Wales.**

England	C.B	M.B	U.D	R.D
Largest	Birmingham 1014670	Poole 107161	Basildon 129330	Meriden 102547
Smallest	Canterbury 33176	Eye 1660	Saxmundham 1709	Masham 1470
Wales				
Largest	Cardiff 279111	Rhondda 88994	Caerphilly 40788	Wrexham 63297
Smallest	Merthyr 55317	Montgomery 968	Llan. Wells 488	Paincastle 1495

Population as at Census of 1971.

Source: See Appendix C.

By the mid-1960s, it was apparent that some type of reform was necessary in the provinces to complement that taking place in the Greater London area. Before terminating operations in 1965, the Local Government Commission had outlined several plans for reform which, by virtue of its terms of reference, it could not implement. Simultaneously, many counties were still carrying out reviews of their internal boundaries under the 1929 Local Government Act and producing quite radical suggestions for reorganisation. In view of mounting evidence of the need for reform, a Royal Commission was appointed in February 1966 to undertake a review of local government in England. Wales was excluded as reform here was based on the Local Government Commission's report for Wales in December, 1962, and a resultant White Paper (Cmd. 3340, July 1967).

The report of the Royal Commission under Lord Redcliffe-Maud was published in June 1969, and contained proposals for a radical restructuring of local government in England. Having proved acceptable to the then Labour government, they were to have been incorporated into a Local Government bill to go before Parliament in the session 1971/2. However, the newly elected Conservative government of June 1970 found the proposals unacceptable, and published a new White Paper in 1971. Together with a consultative document published by the Welsh Office at the same time (based on the 1967 White Paper), this formed the basis of the 1972 Local Government Act.



This Act totally restructured local government in England and Wales. In contrast to the 46 counties subdivided into 80 county boroughs, 227 municipal boroughs, 449 urban districts and 410 rural districts, a pattern of 45 counties emerged, subdivided into 369 districts (excluding the GLC and the Isles of Scilly, the latter being included with Cornwall for census enumeration). Six new metropolitan counties were formed - the major conurbations of Greater Manchester, Merseyside, South Yorkshire, Tyne and Wear, West Midlands and West Yorkshire, subdivided into 36 metropolitan districts in total. The remaining 39 counties were based to a large extent upon the old counties except in Wales, where 13 counties were reduced to eight in number. Three totally new non-metropolitan counties in England were created (Avon, Cleveland and Humberside), whilst the smallest old counties were amalgamated to or with larger ones - Cumberland and Westmorland to the new county of Cumbria, and Rutland to form a new district of Leicestershire. The 39 non-metropolitan counties were subdivided into 296 non-metropolitan districts, the 402 districts in total replacing completely the former system of county and municipal boroughs and urban and rural districts. Within the new areas, the disparity in the size of population is no less great than within the old areas, as illustrated by table 4.3.

The major reorganisation of 1974 did not mark the end of the alteration of boundaries. Over the period May 1974 to June 1981, some 13 changes in boundary have been recorded in England and

Table 4.3: Population of post-1974 local government areas  
in England and Wales.

	Largest	Smallest
Metropolitan Districts	Birmingham 1097961	S. Tyneside 177083
Non-Met. Districts (England)	Bristol 426657	Teesdale 24530
Non-Met. Districts (Wales)	Cardiff 287598	Radnor 18279
London Boroughs (see note)	Lambeth 307516	Kingston-u-Th. 140525

Population as at Census of 1971; data reaggregated by OPCS.

'London Boroughs' excludes the City of London (population 4245).

Source: See Appendix C.

Wales (they are published by the government as Local Statutory Instruments). Fortunately, the population affected by these changes is not great; if it were, they would affect the continuity of data between the 1971 and 1981 Censuses as much as have the previous boundary changes during this century.

#### 4.1.2 Development of local government areas in Scotland

The evolution of the present local government areas in Scotland has followed a much more stable course than its counterpart in England and Wales, apart from one major change earlier in this century.

Local government in Scotland originates from the 12th century, when a number of burghs were granted control over trade within their boundaries (COI, 1972). By the early 19th century, whilst some of these burghs were functioning effectively as local government areas, others - as in England and Wales - had become hopelessly corrupt and inefficient, ruled by self-appointed councils. Parliamentary reform, originating in England and Wales in 1832, spread to Scotland where, by 1850, three classes of burgh (Royal, Barony and Police) had been established (see figure 4.2), all effectively governed by popularly elected commissioners. At the turn of the century, then, Scotland was divided into burghs and extra-burghal county areas; the latter were under the control of elected county councils, and termed

**Figure 4.2: Development of Local Government Areas in Scotland.**

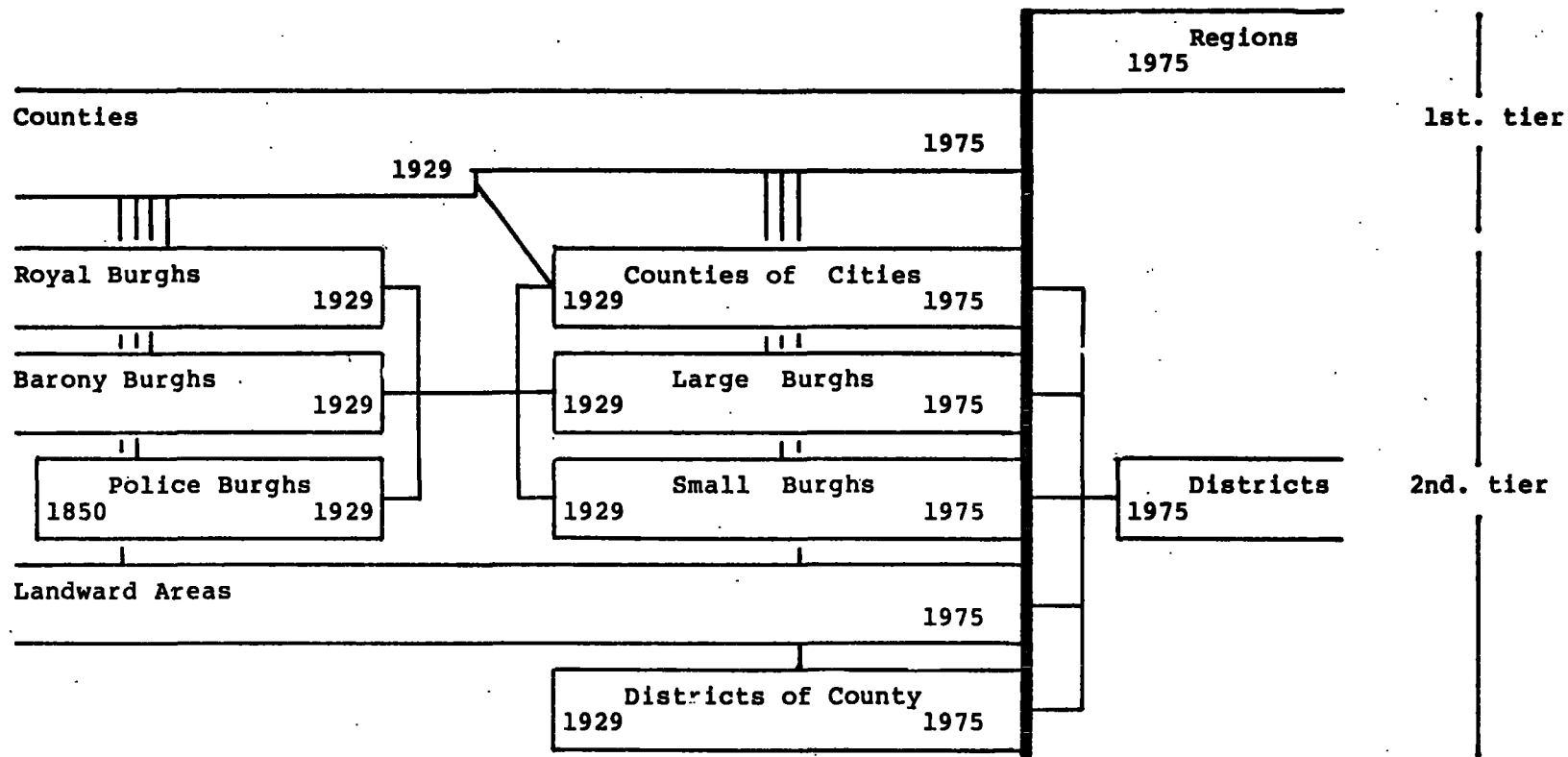

In all areas the parish forms a third tier.

Source: Compiled from basic data.

landward areas. This dual system of burghs and landward areas continued to be used for census taking purposes until 1929, when the Local Government (Scotland) Act was passed, alongside its English counterpart. Under this Act, the landward areas of counties, previously divided only into parishes, were re-divided into county districts (or districts of county, DCs), each being a group of parishes; this in effect introduced a third tier to the hierarchy of areas. Another clause in the same Act reformed the status of burghs; the old classification of three types was replaced by a new one, also of three. The four largest cities of Edinburgh, Glasgow, Aberdeen and Dundee were created as counties of cities, whilst the remainder were divided on population size into large and small burghs.

The system of counties of cities, large and small burghs and districts of county remained in force until 1975. That Scottish local government areas are very much more stable than their English counterparts is confirmed by table 4.4; the number of boundary changes is less than would be expected, even allowing for a much smaller population and a shorter time span over which they can be determined (1931 - 1971 cf. 1901 - 1971 as in England and Wales). Furthermore, the third level of the hierarchy, the parish, exhibits very little change at all (although there is little data published at this level, except for recent censuses).

As in England and Wales, and perhaps because of this lack of change, the areal basis of local government was felt to be increasingly inefficient during the 1960s. A smaller base

Table 4.4: Boundary changes in Scotland.

	a	b	c	d	e	f
Counties of cities	4	4	0	6	1	1
Aberdeen	18	10	8	5	0	2
Angus	13	7	6	3	0	3
Argyll	16	0	16	0	0	0
Ayr	26	13	13	6	4	1
Banff	17	2	15	0	0	1
Berwick	7	2	15	0	0	1
Bute	5	0	5	0	0	0
Caithness	7	2	5	0	1	0
Clackmannan	6	2	4	0	1	0
Dumfries	15	3	12	2	0	0
Dunbarton	12	9	3	3	3	4
East Lothian	12	10	2	1	3	1
Fife	32	17	15	6	7	2
Inverness	12	4	8	2	0	0
Kincardine	9	1	8	1	0	0
Kinross	2	0	2	0	0	0
Kirkudbright	11	3	8	0	0	1
Lanark	17	14	3	4	4	6
Midlothian	13	7	6	2	3	0
Moray	12	5	7	2	1	2
Nairn	2	2	0	0	1	1
Orkney	12	3	9	0	0	2
Peebles	6	2	4	0	0	1
Perth	17	12	5	3	1	6
Renfrew	12	7	5	3	1	0
Ross and Cromarty	18	8	10	1	1	2
Roxburgh	8	3	5	1	0	0
Selkirk	4	3	1	2	0	0
Shetland	15	3	12	1	0	3
Stirling	14	7	7	4	1	0
Sutherland	7	0	7	0	0	0
West Lothian	12	9	3	4	0	4
Wigtown	6	4	2	1	1	0
<b>Total</b>	<b>399</b>	<b>178</b>	<b>221</b>	<b>64</b>	<b>34</b>	<b>43</b>

Total number of boundary changes = 141

a = Total number of local government areas.

b = Total number of changed areas.

c = Total number of unchanged areas.

d = Number of boundary changes: 1961 - 1971

e = 1951 - 1961

f = 1931 - 1951

See also notes to Table 4.1.

Source: See Appendix C.

population and a general decline in population numbers throughout the 20th century have resulted in gross disparities in the number of people within each type of local government unit, as table 4.5 illustrates.

Quite obviously some of the above areas were inadequate and ill-suited to the modern role of local government; Hanson and Walles (1969) cite an extreme example for illustrative purposes. Of the 175 small burghs, each of which was a housing authority, 56 had under 2,000 inhabitants in 1961 (53 in 1971). The housing programme of many of these was just one house per year with many more in the five to ten bracket.

Clearly the same type of reform was needed as had proved necessary in England and Wales, i.e., a marked reduction in the number of local authorities. A White Paper published in 1963 paved the way for the appointment of a Royal Commission on Local Government in Scotland in 1966, the same time as that for England was announced.

Following the publication of the Commission's report in 1969, new proposals for reform were introduced in February 1971, and, after some modification, passed through Parliament as the Local Government (Scotland) Act, 1973. As in England and Wales, the Act markedly reduced the number of constituent areas from 399 to 56, based on a two tier system of regions (ten)<sup>1</sup> and districts (56). The largest district is, not surprisingly, the city of Glasgow, with a population of 982,315, and the smallest, Badenoch and Strathspey in the Highlands, with a population of only 9,309,

---

1. Includes the Island areas as one region.

Table 4.5: Population of pre-1971 local government areas  
in Scotland.

	Largest	Smallest
Counties of cities	Glasgow 897483	Aberdeen 182071
Large Burghs	Paisley 95357	Port Glasgow 22398
Small Burghs	Cumbernauld 31784	New Galloway 338
Districts of County	No.6., Lanarkshire 67877	Cumbræ 56 (see note)

Population as at Census of 1971.

The smallest non-insular DC was Bo'ness, with a population of 514.

Source: See Appendix C.

both in 1971. Although there is a disparity of population as great as before, this can be explained by the lower overall population densities in Scotland - the areas are at least more functional than pre-1975, while at the same time not extending to cover the extremely large areas which would be required to equate the population sizes with those of local government areas south of the border. As in England and Wales, however, some eight modifications to boundaries have been made over the period from June 1975 to June 1981 - one of which was almost immediately revoked! In all cases, the number of people involved was small.

It is not within the scope of this research to discuss whether or not continued alterations in boundary have ultimately been of benefit to local government. Whilst they are in some respects inevitable since the data must be collected for regions which are either functional ones and / or have some administrative significance (and will therefore change under economic development and population shifts), from the author's point of view they can be regarded as nothing more than a hindrance to the construction of a valid time series of data from a source which is otherwise reliable, regular and of known standards of accuracy. In conclusion, it is hard to disagree with an observation by Gaius Petronius in Satyricon (quoted in Jackson, 1976) that

'We tend to meet any new situation by reorganising, and what a wonderful method it can be for creating the illusion of progress, whilst producing confusion, inefficiency and demoralisation.'

The Census of Population could only be used as a source of time series data if some way round these changes in boundaries of areal zones were to be found; a method for this is examined in section 4.3.

#### 4.2 THE MID-YEAR ESTIMATES

In view of the problems with census-derived data which result mainly from boundary changes over time, the idea of using such data for mapping was initially shelved. Instead, use of the mid-year estimates of population was considered and, indeed, the first computer-animated film was made from these data.

##### 4.2.1 Calculation of the mid-year estimates

Annual estimates of the population of local authority areas have been made by the Registrar General since 1915 (1911 for county boroughs), and published yearly in the Registrar General's Statistical Review (Knight, 1980, pers.comm.)<sup>1</sup>. Clearly this is of much higher temporal frequency than the censuses carried out under the 1920 Census Act: some 65 mid-year estimates of population are available in England and Wales, in contrast to the seven available from censuses and the 1939 registration. Over this time period, the method of estimation has changed

---

1 S. Knight. Dept of the Environment.

substantially to keep in step with changing sources of information (OPCS, 1980d) but the present method originates from 1950 when the abolition of National Registration and the ending of rationing meant that some other means for the estimation of the population of each area had to be found. The system at present in use is based on estimating population change through births, deaths and migration, and applying the result to a basic stock of population. This can be contrasted with a direct count, and is preferable in that data relating to population change are more readily available; the basic stock is a figure of known accuracy enumerated for each local authority area at the decennial census. To this are added the number of <sup>end in-migration</sup> births; the number of deaths and the amount of <sup>out</sup> migration are then subtracted. Figures for births and deaths are readily available, since it is compulsory to register them, whilst data on migration is much more difficult to obtain. Repeating this estimate annually until the next census is liable to introduce compounded error; it is for this reason amongst others, that the cancellation of the 1976 Census is to be regretted (Clarke, 1975). However, even allowing for such errors, the population change method is preferable to a direct count, in that the latter is both difficult and expensive to administer if it is to be of sufficient accuracy and of national coverage.

The above description forms a general outline of the methodology used since 1950. However, over this time period, developments in the availability and reliability of both data and

computational methods, helped by the development of the computer for handling increased amounts of data, have meant that (until 1976) no two successive years of estimates used absolutely identical sources and methods.

The results of the 1971 Census of Population showed the 1971 mid-year estimates in some places to be very inaccurate; the extreme case was an overestimate in comparison with the census of 8% (51 thousand persons) for the city of Liverpool, later attributed to a gross underestimate of out-migration from the city (Jones et al, 1973). Partly as a consequence of this, and partly because one source of data became unavailable, the method for estimating migration had to be changed. Furthermore, the cancellation of the 1976 sample census (Clarke, 1975) meant that a new basic stock, from which to continue the estimates until 1981, was no longer available; in view of the use to which the mid-year estimates are put (including their input to the calculation of the Rate Support Grant and its successor, the Block Grant), increased accuracy was needed. Finally, even if the estimates had all been calculated using the same base data and the same methodology, estimates throughout the early 1970s would be non-comparable due to local government reorganisation, and the consequent change to the areal base (as described in section 4.1).

Hence, in 1976, OPCS decided to carry out a retrospective recalculation for data from 1971 onwards, recasting them onto a post-1974 areal base and to use the same method for estimates up

until the 1981 census. As a consequence this was expected to produce at least a decade of approximately comparable figures. It is this series of figures which were used in the first computer-animated film; the series is now examined further.

In keeping with their name, mid-year estimates are held to represent the population as at the 30th June each year. Thus the basic stock on which all changes are enacted is the Census of April 25/26th 1971. The totals for each local authority as re-aggregated by OPCS are used. This figure is then aged to represent the population as at 30th June, 1971 - this is necessary as the mid-year estimates for the London boroughs, metropolitan districts, and all counties are broken down by age as well as sex (data for non-metropolitan districts are broken down by sex only). For each local authority the population represents that 'usually resident'. The definition of this is almost the same as in the Census, with two exceptions: students are, for the purpose of the mid-year estimates, usually resident at their term-time address, and the armed forces at their station - in both cases these are rarely synonymous with their 'usual residence' as defined by the Census. The basic stock as at 30th June 1971 is then corrected for these two groups of people.

Annual corrections are made to this figure representing change in the population. These changes stem from four sources: births, deaths, migration and changes in the institutional population of the area. Data on births and deaths are readily available and are simply added or subtracted to the basic stock. The

estimation of migration has always proved to be more difficult. Prior to 1971, this was done using two sources of data, the Electoral Register and the Housing Development Return (HDR) as supplied by each local authority. The latter was a record of the number of new houses completed, old ones demolished and known changes in ownership / occupancy, together with an estimate of the population involved. In explaining the inaccuracy of the 1971 mid-year estimates in comparison to the census, OPCS held this latter source of data to be responsible. With hindsight, this is easily explained. First, HDRs were not completed by every local authority. Secondly, most authorities supplied figures consistently too low (through internally incomplete returns) or too high (through trying to estimate for incomplete returns). Estimating the numbers of people involved, then, was doubly hazardous. Errors also exist in the Electoral Register. However, these errors tend to be self-correcting sooner or later; this contrasts with errors in the HDR - if something was omitted, it was unlikely to be included in subsequent years (OPCS, 1980d).

The HDR, having been shown to be unreliable, was later abolished in the early 1970s (OPCS, 1978a), and at and since the recalculation of figures in 1976, migration has been estimated using the Electoral Register alone. Service personnel (who can be identified separately within it), and attainments (17 year olds on it) are removed, then with certain adjustments for a known underestimation of about 1% (based on the difference between the number of persons aged 18 plus nationally and the total of those

on the Electoral Register), the change between figures for two successive years is held to represent net migration for the area. For the recalculated period 1971 to 1976, net migration for those people aged under 18 was estimated as a simple proportion of those aged over 18; since 1976, use has been made of DES data (for 7-15 year olds), and the National Health Service Central Register (NHSCR) for 0-6 and 16-17 year olds. A national check of migration figures is obtained by comparing their sum with total net migration for the country as obtained from the International Passenger Survey and the NHSCR; any discrepancies are shared out amongst all districts.

The fourth area of change in the population total of a district occurs within institutional populations. The Home Office is able to supply a detailed breakdown on the number of prison inmates by sex, and prison, and changes can easily be calculated by comparison of two successive years of data. Each local authority can supply figures for those in residential educational establishments, and finally, for armed forces (both British and foreign), data can be obtained from the Ministry of Defence. For each of these three classes of persons, obviously a compensating adjustment has also to be made to the individual's area of 'usual residence'.

#### 4.2.2 Accuracy of the mid-year estimates

OPCS do not claim very high accuracy for their mid-year estimates. Those derived from the recalculation of 1976 ought to be improvements on those available previously - the maximum change between the original and revised figures in any authority being 4% (OPCS, 1978a) which is half the maximum error obtained by comparison of the census and mid-year estimate figures for 1971. However, updating a basic stock over nine rather than four years will compound any errors. Over this time period slight changes in the quality of data sources used could exacerbate the situation. It is not known what the errors are at present (if it were, they could be expunged) or precisely from where they originate. However, it seems likely they originate mainly from data relating to migration of the population. Despite improvements incorporated in 1976 (especially the cessation of use of the HDR and inclusion of DES and NHSCR data), sources of British migration data are indirect and hence poor; until they improve, the mid-year estimates are likely to be error-prone.

It is difficult to provide a bounding figure for the accuracy of the estimates; this cannot be done with certainty until data emanating from the 1981 Census becomes available. However, in connexion with a recent survey of planning officers, the following facts emerged. The OPCS estimate of the 1979 population of Wansbeck District, Northumberland, is 61 thousand. A survey throughout the area, carried out in conjunction with the

electoral registration in 1979, revealed the population to be 62.1 thousand, a difference of some 1.8% (Jacobson, 1980, pers.comm.)<sup>1</sup>. In Wyre, Lancashire, a similar exercise by the district council in 1979 indicated a population of 100,878 which, in comparison to the OPCS figure of 98,200, shows a difference of 2.7% (Leech, 1980, pers.comm.)<sup>2</sup>. Errors exist in the opposite direction: the city of Manchester enumerated their 1978 population to be 484,128, some 5,172 less than the OPCS estimate of 489,300 (Parnell, 1980, pers.comm.)<sup>3</sup>. These are just three cases which emerged from the author's survey of all planning officers: it is not possible to say whether they represent the extremes of error or not. That they are not the only large ones however, seems very likely.

Given such errors, it is arguable that more use should be made of local authority data, rather than that produced by OPCS - not only for this research, but for issues of far greater national importance such as the allocation of the Block Grant. Some authorities, such as the first two cited above, take actual counts in conjunction with the annual electoral registration; these should produce figures of far greater accuracy than the OPCS estimates. In any event, a detailed knowledge of local affairs should lead to a more representative figure. But, set against this, is the fact that if each local authority's estimate is summed, the total represents more than the national population (OPCS, 1978b). Complications occur in that local surveys may have been carried out at different times; moreover, non-response

---

1 I. Jacobson. Wensbeck District Council  
2 R. Leech. Wyre District Council  
3 S. Parnell. City of Manchester Metropolitan District Council

can be a severe problem especially when, unlike the Census, there is no compulsion to answer. Additional refinement of the Electoral Register (perhaps to include those under 17 years of age) will certainly be expensive; is unlikely to guarantee more accurate data; and may also be held by some to represent an invasion of privacy (OPCS, 1980b). Estimates based on housing stock are subject to the same problems as those associated with the HDR (see above), whilst health service and education records may be in error in that they include people using the service, but who may not necessarily reside within the district. Hence there is much to be said for the production of estimates using a method for all areas, and which is repeated regularly; if errors do exist, the summed population can be scaled to equal the national total. For this research, there is a further advantage in using the OPCS figures in that they are available from a central source in one document, the OPCS Monitor series. The workload involved in obtaining a figure from each authority would be very considerable indeed.

#### 4.2.3 The mid-year estimates for Scotland

The mid-year estimates for Scotland, as calculated by the GRO(S), are derived by much the same processes as for England and Wales. The major difference lies in the estimation of migration; here more data sources are used, including assessor and housing

returns and employment data (Travers, 1980, pers.comm.)<sup>1</sup>. A second difference is that data sources change very frequently and slight differences in the methodologies used occur every year. In this research, such differences are ignored and the Scottish mid-year estimates are used alongside those for England and Wales and held to be compatible.

#### 4.2.4 Problems associated with the use of the mid-year estimates

The data used for the production of the first film then were the mid-year estimates for the years 1971 - 1978. Detailed sources of these data are given in appendix C. At the time, the 1979 and 1980 mid-year estimates were unavailable; they have since become so, and have been added to the series. In using these mid-year estimates, no such problems as a change in methodology of derivation were encountered, and slight changes in district boundaries (as detailed in section 4.1) were ignored. The data set was complete (with no missing values) and although, as outlined above, its accuracy was questionable, this was of no great initial concern to the author - it was simply used to test a cartographic process under examination.

The main cartographic problem encountered was simply a lack of significant change within the data set. Table 4.6 lists those areas showing the highest and lowest absolute and percentage

---

1. L. Travers. GRO(S).

increases. Although some of these are quite impressive, the lists are dominated by city centres, London boroughs, new towns and Scottish districts showing high percentage increases, the last areas owing to oil developments. In spatial terms these areas are often very small and thus do not lead to an interesting map. Conversely, the larger Scottish areas of rapid population change contain few people. Over the majority of Great Britain, the population was inherently stable (Clarke and Mounsey, 1980) showing an increase of only 266,000 (0.4%) for the period 1971 to 1979. Furthermore, the average difference by districts (total increase / 458 districts) was an increase of only 600 persons. The results of filming these data were not impressive; the map was dominated by the only geographically large districts exhibiting change - those in the Scottish Highlands.

#### 4.3 DERIVATION OF A CENSUS-BASED POPULATION DATA SET

Since major problems arose with the use of the mid-year estimates as a time series, it was decided to attempt to create a data set utilising census data over the period 1901 - 1971. In using census data, some procedure had to be found to cope with the extensive alterations in local government boundaries, both at and preceding 1974 in England and Wales, and 1975 in Scotland, as outlined in section 4.1. Some 659 authorities (438 in England and Wales, 221 in Scotland) underwent no alteration at all during

Table 4.6: Change in population of selected areas, 1971 - 1979.

1) Percentage change (absolute change in thousands in brackets).

Lowest:	Kensington and Chelsea	-20.39%	(-38.4)
	Glasgow (City)	-18.88%	(-184.9)
	Islington	-16.43%	(-32.9)
	Southwark	-15.95%	(-41.6)
	Liverpool	-14.06%	(-85.1)
	Hackney	-13.16%	(-28.9)
	Lambeth	-13.00%	(-39.8)
	Manchester	-12.33%	(-67.4)
	Lewisham	-11.23%	(-30.1)
	Westminster City	-10.78%	(-25.6)
Highest:	Breckland	28.52%	(21.7)
	Ross and Cromarty	28.61%	(9.9)
	Wimborne	29.29%	(15.2)
	Gordon	31.92%	(14.3)
	Forest Heath	33.02%	(14.0)
	City of London	34.15%	(1.4)
	Cumbernauld and Kilsyth	36.19%	(16.9)
	Tamworth	46.36%	(19.1)
	Redditch	56.07%	(23.1)
	Milton Keynes	69.79%	(46.9)

2) Absolute change (percentage change in brackets).

Lowest:	Glasgow (City)	-184.9	(-18.88%)
	Liverpool	-85.1	(-14.06%)
	Manchester	-67.4	(-12.33%)
	Birmingham	-63.2	(-5.76%)
	Southwark	-41.6	(-15.95%)
	Lambeth	-39.8	(-13.00%)
	Kensington and Chelsea	-38.4	(-20.39%)
	Islington	-32.9	(-16.43%)
	Lewisham	-30.1	(-11.23%)
	Wandsworth	-29.2	(-9.67%)
Highest:	West Lothian	19.9	(17.72%)
	Northampton	21.7	(16.29%)
	Breckland	21.7	(28.52%)
	Basingstoke	22.6	(21.61%)
	Redditch	23.1	(56.07%)
	Peterborough	23.3	(56.07%)
	Halton	24.1	(21.98%)
	The Wrekin	24.7	(24.95%)
	Huntingdon	25.7	(25.75%)
	Milton Keynes	46.9	(69.79%)

Source: See Appendix C.

the period 1901 - 1971, and so here the problem of boundary changes did not arise; in these cases the population data were simply coded from the relevant volume of the census. However, for the remaining 1,206 areas (1,028 in England and Wales, 178 in Scotland), a procedure was adopted which, although rather crude, gave acceptable results: this was based on the number of people, rather than the actual area, being transferred, and the following describes its application for the period 1901 to 1971.

Boundary changes may result in three different conditions (see figure 4.3). First, a number of people who were previously enumerated in area A will now be counted in area B. Although no actual migration of the population is involved, it is convenient to describe this as a movement of N persons from A to B. Both areas remain in existence after the change. Secondly, there are what have come to be termed 'dead areas'. These are local authorities which, by amalgamation into one or several neighbouring areas, have ceased to exist. Finally, there is the converse of this situation, the so-called 'new areas'. Here an area is created, consisting of one or several parts of old or 'dead' areas. Although each of these processes can result in a very different areal arrangement of authorities, the procedure adopted to allow for boundary changes was similar in all cases.

The central tenet of this method is that the ratio of the number of people in the area 'moved' to the number of people in the 'parent' area (the population of the area before the boundary change) has remained constant through time i.e.

Figure 4.3: Types of boundary change.

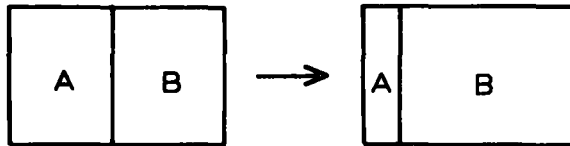

1: Adjustment of boundary.

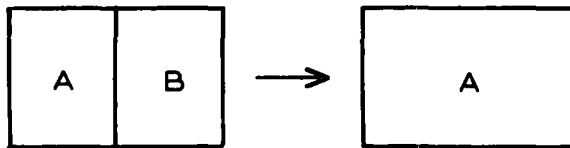

2: B = Dead area.

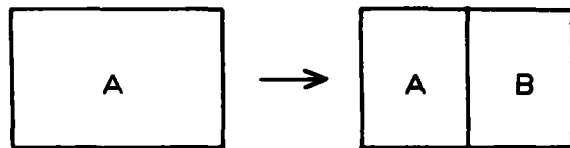

3: B = New area.

$$\frac{P(n-3)x}{P(n-3)X} = \frac{P(n-2)x}{P(n-2)X} = \frac{P(n-1)x}{P(n-1)X}$$

where P = population of area x  
x = part of area X transferred  
n = current census year.

In certain cases, namely New Towns, this is obviously a false assumption, but this problem will be discussed further in chapter 5. Thus the number of people moved can be expressed as a percentage of those in the parent area; at all censuses previous to the date of the boundary change, this percentage may be subtracted from the 'source' area and added to the 'sink' area, resulting in an approximation of the population as spatially defined in 1971.

In the case of 'dead' areas, no problems arise if the area has been merged intact into another or new area. However, if it has been split between several neighbouring areas, then the population moved to each area is taken as a percentage of the parent population, and at all previous censuses the 'dead' area's population is divided according to these percentages. The population of new areas, which obviously do not occur in previous census volumes, are simply calculated from parts of old or 'dead' areas, derived by the same method.

This whole procedure is only made possible by the existence, in every county volume and at each census, of a table recording any inter-censal changes in boundary for that county. Although the exact layout of this table varies with each census, four

items of information are always recorded: the title of the Act of Parliament or Statutory Order giving authority for the change and its date; the source area; the sink area; and the population of the area transferred, as at the previous census. This latter figure is used as the numerator in the percentage calculation, with the original population of the area as the denominator. For example, the 1971 North Yorkshire census volume records 1,283 people as being transferred from Guisborough UD to the newly created Teesside CB in 1966. The population of Guisborough in 1961 (from the county census volume of that year) is listed as 12,079. Hence the percentage is calculated to be  $(1283/12079)*100$  and rounded to give 11%. Ignoring any earlier change of boundary in the area, this figure would be used to allocate the appropriate part of the North Yorkshire population to Teesside at each earlier census. If the resulting percentage was less than 1%, or if the population of the area transferred did not form 1% of the new area (as defined by the boundary change), then the transfer was not recorded. This was done primarily to reduce the number of calculations, especially as the numbers of people involved at this level of detail were very few.

In summary then, in order to encode the population of areas on a 1971 areal basis, it was necessary to work backwards through time and accumulate changes to be applied to any area as coding progressed. Due to a difference in structure between the Scottish, and the English and Welsh local government areas, the encoding of population and recording of boundary changes did not

follow the same pattern in each case. The following stages describe in more detail the process as implemented for the two national groupings.

#### 4.3.1 Encoding population for England and Wales

Stage I Each 1971 Local Authority was assigned a computer code, identical to that used by OPCS on magnetic tapes of the 1971 Small Area Statistics (SAS). If an area was split between counties as a result of the 1974 Local Government Act, OPCS assigned two or more codes, one for each post-1974 segment. (For example, Wantage RD as at 1971 has two codes, one for the part moved to Oxfordshire, and one for the part remaining in Berkshire.) Similarly, two codes were assigned by OPCS to areas containing a New Town, one representing the area within, and one the area outside, the latter. In each of these cases the first code was used in the process, and difficulties would therefore arise in any subsequent attempts to match the encoded population data relating to a specific area with the 1971 SAS for the same area by computer code alone.

The population figures for 1951, 1961 and 1971 were then encoded for each area, utilizing Table 2 of each county volume for 1971. Also encoded were the county totals - to be used in checking for errors at a later stage. If any boundary changes had occurred during this time period, these had been accounted

for by OPCS before tabulation; i.e. the figures in the table all relate to the area as constituted in 1971, and no reworking on the author's part was necessary. To clarify the encoding process, a worked example is illustrated in figure 4.4. The example uses the local government areas of Stockton RD and MB, and Billingham UD, all involved in the creation of Teesside CB in 1966. Stockton MB and Billingham UD represent 'dead areas' in that they were amalgamated to Teesside CB. At this stage, then, only the population of Stockton RD was coded in the example.

Stage II Boundary changes for the inter-censal period 1961 to 1971 were recorded from Table 4 of the 1971 county census volumes, each change being expressed as a percentage of the 1961 population of the old area. No actual figures for the number of people moved were ever recorded as this was not felt to be necessary. The example shows some of the many boundary changes caused by the creation of Teesside CB.

Stage III This was identical to Stage II, for the inter-censal period 1951 to 1961, using 1951 as a base year for calculations.

Stage IV Boundary changes for the period between the date of publication of the second part of each 1931 county census volume, and 1951, were recorded from the 1951 county volumes, Table 5. For convenience, the former date is referred to in text and tabulations as 1935, although in practice, the actual date of publication and that used in calculations varies widely between counties, covering the period 1932 to 1937. Examination of table 4.1 shows there to be the fewest changes in boundary during this

Figure 4.4: To illustrate the method of calculation.

(da = dead area, na = new area).

Stage I. Population totals for 1951, 1961 and 1971.

	1951	1961	1971
Stockton RD	7978	9270	13287

Stage II. Boundary changes, 1961 - 1971.

Source area	Sink area	% transferred
Stockton RD	Hartlepool CB (na)	4%
Stockton RD	Teesside CB (na)	5%
Stockton MB (da)		100%
Billingham UD	Stockton RD	99%
Billingham UD (da)		1%

Stage V. Population estimates for 1939.

for Stockton MB:	original population	66688
	100% -> Teesside CB	-66688
	Dead area	= 0
for Billingham UD:	original population	20228
	99% -> Teesside CB	-20026
	1% -> Stockton RD	- 202
	Dead area	= 0
for Stockton RD:	original population	7920
	4% -> Hartlepool CB	- 317
	5% -> Teesside CB	- 395
	+ Billingham UD (1%)	+ 202
	Estimated population	= 7410

Stage VI. Population estimates for 1921 and 1931.

	1921	1931
for Stockton MB:	original population	64126
	100% -> Teesside CB	-64126
	Dead area	= 0
for Billingham UD:	original population	9389
	99% -> Teesside CB	- 9295
	1% -> Stockton RD	- 94
	Dead area	= 0
for Stockton RD:	original population	8010
	4% -> Hartlepool CB	- 320
	5% -> Teesside CB	- 401
	+ Billingham UD (1%)	+ 94
	Estimated population	= 7383
		= 7306

Figure 4.4 continued.

Stage VII. Boundary changes, 1931 - 1935.

Source area	Sink area	% transferred
Stockton RD	Billingham UD	20%
Hartlepool RD (da)	Stockton RD	65%

Stage VIII. Boundary changes, 1921 - 1931.

Source area	Sink area	% transferred
Stockton RD	Billingham UD (na)	55%

Stage IX. Boundary changes, 1911 - 1921.

Source area	Sink area	% transferred
Stockton RD	Stockton MB	45%

Stage X. Population estimates for 1901 and 1911.

		<u>1901</u>	<u>1911</u>
for Stockton RD:	original population	14819	17530
	45% -> Stockton MB	- 6669	- 7889
		= 8150	= 9641
	55% -> Billingham UD	- 4483	- 5303
		= 3667	= 4338
	20% -> Billingham UD	- 733	- 868
	+ Hartlepool RD (65%)	+ 1875	+ 2181
		= 4809	= 5651
	5% -> Teesside CB	- 240	- 283
	4% -> Hartlepool CB	- 192	- 226
+ Billingham UD (1%)	+ 52	+ 62	
	<u>Estimated population</u>	<u>= 4429</u>	<u>= 5204</u>
for Billingham UD:	new area (from above)	= 4483	= 5303
	+ Stockton RD (20%)	+ 733	+ 868
		= 5216	= 6171
	99% -> Teesside CB	- 5164	- 6109
	1% -> Stockton RD	- 52	- 62
	<u>Dead area</u>	<u>= 0</u>	<u>= 0</u>
for Stockton MB:	original population	51478	52154
	+ Stockton RD (45%)	+ 6669	+ 7889
		= 58147	= 60043
	100% -> Teesside CB	- 58147	- 60043
	<u>Dead area</u>	<u>= 0</u>	<u>= 0</u>

Source: Calculated from basic data.

time period over the total period of study (1901 - 1971) - there were none in the example - and in the majority of these, the population of the area transferred is recorded as that in 1931, with the actual 1931 population being used as the denominator. However, in a very few cases, the General Register Office found it impossible to determine the 1931 population of the area transferred, and so substituted the 1951 figure instead. In these cases, the denominator is then hypothetical, calculated to be the sum of the remaining population in the source area in 1951 (if any), plus the population (as at 1951) of all areas transferred. Since the basic premise of this methodology is that the percentage remains constant over time, its calculation based on 1951 figures (after the boundary change) as opposed to the 1931 figures (before the change) is not thought to constitute a serious problem. At this stage only, the date of the boundary change was also recorded, to be used at the next stage.

Stage V The population figures for 1939 were encoded, applying any post-1939 boundary changes previously recorded. At this stage, the source of data was a document listing the results of the 1939 National Registration of the population, published in one volume, at county, local authority and civil parish level. During the encoding it became apparent that the reliability of this data source should be questioned for, as table 4.7 shows, a common characteristic found throughout was a marked underestimation of population in the largest centres, with a corresponding overestimation at all other levels.

Table 4.7: Population of selected areas, 1921 - 1961.

	1921	1931	1939	1951	1961
Sunderland CB Co. Durham	206942	210885	190115	206815	218645
Newbury MB Berkshire	13028	14242	18124	17783	20397
St. Ives UD Huntingdonshire	6749	6642	8011	7784	8821
Cuckfield RD East Sussex	18671	19627	28111	24268	30095

Source: See Appendix C.

Though the figures obviously do not fit the general pattern of population change, they were included for completeness, forming the only population statistics available between 1931 and 1951 to the author at the time of encoding. Possible reasons for their inaccuracy are included in chapter 5.

The example shows the method of estimating the population for the three areas for 1939: the populations of Billingham UD and Stockton MB are summed together with those of the other constituent parts of Teesside CB to give an estimate of the population for this latter area. The county totals for Durham and North Yorkshire are adjusted by 86,714 (=20,006+66,688) as both Stockton MB and Billingham UD (part) were formerly in Durham but were 'moved' to North Yorkshire on the creation of Teesside CB.

Stage VI The population figures for 1921 and 1931 were encoded, incorporating any post-1931 boundary changes. The data were taken from Part 2, Table C of each county census volume for 1931, that being the section in which both the 1921 and 1931 data have been reaggregated to the areas as constituted following the particular County Review Order. For error-checking purposes, the county totals were also encoded for each year - in the example the Durham and North Yorkshire totals were adjusted as at Stage V.

Stage VII Boundary changes were recorded for the period 1931 to 1935, utilizing Table B of Part 2, the county census volumes. As at stage IV, the numerator was the 1931 population of the area

transferred and the denominator the actual population of the old area. This stage was by far the longest in the whole process for, as table 4.1 shows, the greatest number of boundary changes occurred during this period.

Stage VIII Boundary changes were recorded for the inter-censal period 1921 to 1931 utilizing Table 5 of Part 1, the 1931 county census volumes. The actual 1921 population of the areas undergoing change was used as the denominator.

Stage IX Stage VIII was repeated for the inter-censal period 1911 to 1921, using Table 6 of the 1921 county census volumes. These were the last boundary changes to be encoded for, as will be shown at the next stage, alterations of boundaries for the inter-censal period 1901 to 1911 were already taken into account.

Stage X The final stage involved encoding of the population data for each area, as modified by all the post-1911 boundary changes. As at stages I and VI, it was possible to code more than one year from one table (Table 5, the 1911 county census volumes), as the 1901 data had been reaggregated to the area as defined in 1911. County totals were also included for checking of errors.

Following the example in figure 4.4, a data set for the whole of England and Wales was derived, covering the period 1901 to 1971. Whilst not perfect - there are a number of errors originating from several sources which are examined in chapter 5 - it does provide a much greater degree of change than that for the eight year period 1971 to 1979.

#### 4.3.2 Encoding population for Scotland

Much the same methodology was used to derive a data set covering the years 1921 to 1971 as that used for England and Wales. However, owing to the division of the landward areas into county districts (DCs), and their subsequent use for census enumeration following the 1929 Local Government (Scotland) Act, for the years 1901 and 1911, a different - and less precise - method had to be adopted.

Examination of table 4.4 shows there to be many fewer boundary changes between Scottish areas than were recorded for England and Wales. Furthermore, these changes tend to occur in the more populous and urbanised lowland counties (the Lothians, Renfrew, Lanark and Dunbarton), indicating the greater stability of boundaries in rural areas. A feature of Scottish boundary changes is that the numbers of people involved are very small; despite recording only changes of above 1% (as done in England and Wales), on two occasions a movement of just ten people became 'significant' and had to be incorporated for previous censuses.

The exact methodology adopted was as follows:

Stage I Population figures for the years 1951, 1961 and 1971 were encoded as for English and Welsh areas. The source of data was Table 2, the county census volumes, 1971.

Stage II Boundary changes for the inter-censal period 1961 to 1971 were recorded, as for England and Wales. Table 4 of the 1971 county census volumes provided the relevant information.

Stage III Stage II was repeated for the inter-censal period 1951 to 1961, using Table 5 of the 1961 county census volumes. Unfortunately, at this stage the Scottish census publications begin to differ from their English counterparts in the amount of information recorded. If the transfer of areas involved a burgh, then the same information as for the English and Welsh areas was recorded (see section 4.3.1). However no details are given for alteration of boundary between DCs only; thus the calculation of the percentage figure posed greater problems. Table 2 of the same census volume records the net population added to or deducted from any area in the inter-censal period, so this was used in place of the missing details of boundary changes. After taking away the sum already accounted for by burghal changes, a number of districts still recorded a net loss or gain - the grand total of the former equalling the grand total of the latter, unless a cross-county inter-district change was involved. In all these cases, it was possible then to determine the source and sink areas by reference to a map, assuming that significant changes only took place between spatially contiguous districts.

Stage IV The population figures for 1921, 1931 and 1951 were encoded from Table 1 of each county census volume. Both the 1921 and 1931 figures refer to the area as constituted in 1951; to these figures any post-1951 boundary changes were applied. County totals were also encoded.

Stage V Boundary changes for the inter-censal period 1931 to 1951 were recorded; however, due to data availability problems at the

next stage, these were never used.

Stage VI It was now necessary to encode the population figures for 1901 and 1911. Unfortunately, as the landward areas of each county were only subdivided into districts following the 1929 Act (as described above), the data available were limited to large and small burghs, landward areas, and civil parishes. Thus some method had to be found for division of the population of landward areas, except in the very few cases where islands, now forming separate districts, were at those dates individual civil parishes. Such cases are to be found mainly in the counties of Bute, Orkney and Shetland. The procedure eventually adopted was to take each district population as in 1931 as a percentage of the landward population in 1931, and then divide the (known) landward populations of 1901 and 1911 accordingly. This technique was by no means satisfactory, but it did allow the data set to be completed - if somewhat inaccurately, as will be shown in chapter 5.

#### 4.3.3 The formation of post-1974 areas, England and Wales

The manually encoded data set was transferred on to 80 column computer cards, and copied to magnetic disk. Having checked the pre-1971 data for errors (see chapter 5), it was now necessary to apply boundary changes resulting from the reorganisation of 1974. This was fairly easily achieved using an OPCS publication (OPCS,

1975b). In this, the composition of each new authority by old authorities is given: using data down (where necessary) to Enumeration District level, OPCS calculated the percentage of the population of any old authority in a new district. In some 50 cases, the new county districts are identical to old areas. These are predominantly the old county boroughs. A further 201 of the new areas are simple contiguous amalgamations of complete old areas, leaving just 92 new areas containing parts of divided old areas (OPCS, 1979). The above figures do not include the City of London or the London boroughs; no change took place within these in 1974 following their major reorganisation in 1966.

OPCS (1975b) gives the population of all the new areas in terms of the percentage of the population of any included old area, rather than the percentage of the actual measured area. Thus, for many local authority districts (those which were directly amalgamated to new areas), the figure is 100%.

The procedure adopted for determining the 1901 to 1971 population figures for the new areas was a simple one. First, each new area was assigned a computer code (identical to that used internally by OPCS). Its composition in terms of old area computer codes (the same as those applied at Stage I of the encoding process) and percentages of the population of the old areas were then recorded. It was now a case of searching by computer through the 1901 to 1971 population data and summing up the relevant cases; if the old areas were split in the

reorganisation, then only the appropriate percentage of the population was added. This procedure was not carried out for the GLC as, by 1971 (the base year for the encoding operation), the districts within this county had already been reorganised. Thus the 1951, 1961 and 1971 figures on a post-1966 areal basis were obtained from the 1971 census, and prior to this date, the census data was reaggregated by hand to the new areas, as coding progressed.

#### 4.3.4 The formation of post-1975 areas, Scotland

The calculation of post-1975 figures from pre-1971 data was more difficult for Scotland than for England and Wales, although the essential processes were identical. Unfortunately, the appropriate conversion manual (OPCS, 1975a) lists only the contributing old areas which make up the new areas, and not, as in England and Wales, the percentage of the old population within the new area. The appropriate percentages for Scotland have never been calculated by GRO(S); for those 14 of the new districts which represent whole amalgamations this is, of course, of no difficulty. For the remaining 42 areas, however, these had to be determined by the author by a variety of means. First, the total population of each new area in 1971 is known, together with the population of each whole old area, from the original (1971) and reaggregated (1975) versions of the 1971 census volumes.

Thus, if a new area contains just one split old area - the remainder being whole old areas - the population total minus the total of the whole old areas gives the number of people originating from the split old area, which can then be expressed as a percentage. This solved 22 of the remaining cases. Secondly, even if a new area contains two split old areas, the remainder of these split old areas elsewhere can often be determined by the first method. Thus, simple subtraction reveals the portion of each in the new area; this method was effective for a further three areas. The 17 remaining new areas contained divided old areas such that two unknowns occurred together, and neither of the above methods was satisfactory. The areas mainly occurred in the Glasgow area of Lanarkshire and Renfrewshire and the problem was solved by breaking the old areas down to civil parishes: the composition of each new area in terms of civil parishes is listed in the reaggregated (1975) census volumes. Fortunately, the Scottish civil parish is perhaps the most stable British local government unit; by reconstructing each part of the split old area from these, and summing up the population totals as recorded in the original 1971 census volumes, the relevant percentage could be obtained. Not all new areas are even whole amalgamations of civil parishes but (fortuitously, by working at this level) two unknowns never occurred together and, despite being very laborious, a complete set of percentages was eventually obtained.

From this point onwards, the procedure was identical to that used for England and Wales; the end result was a set of population figures for the post-1975 Scottish areas covering the period 1901 to 1971.

Thus a data set comprising eight population totals (seven censuses and one national registration) was created, covering each of the 458 new districts of England, Wales and Scotland. The process was a long one - over 7,000 calculations were made by hand and an equally large number by computer - but it did result in a time series data set for use in animated filming. With reference to figure 3.1 (page 39) and as noted in section 3.1, the acquisition of a time series data set is often a case of juggling the method of data collection v. the attributes of the data set. In this case, the end result is a data set of consistent attributes: whether the method of data collection meets the requirements as laid down in the framework of figure 3.1, however, is a different matter. The process was certainly operationally definable and carried out repeatedly in both time and space (see sections 4.3.1 and 4.3.2) but the accuracy of the resulting data set remained unproven. In the following chapter, this facet is investigated, along with steps taken to increase accuracy where shortcomings were revealed.

## 5 VALIDATION OF THE DATA SET

Throughout the entire coding and calculation process, numerous problems arose, and potential for error existed. This chapter examines sources of such errors, steps taken to correct them, and the limitations of the final data set. The chapter is divided into five sections: first, it describes a preliminary check on the data set. Secondly, a survey of planning officers is discussed, carried out to assess the validity of the results of the data collection process on the basis of local experience. The third and fourth sections describe further checks on the data set and an interpolation process carried out to generate a matrix of population totals for input to an animated film. Finally the topographic data, needed to map the population data, are described.

### 5.1 ERROR CHECKING: THE FIRST STAGE

As a check for errors which arose during the manual encoding process (sections 4.3.1 and 4.3.2) a crude, but effective, method was used, based on a comparison between the actual coded county total at any one date, and the total as obtained by summing up its constituent parts. More specifically, a percentage figure was derived equal to

$$(T_c - T_s / T_c) * 100$$

where  $T_c$  = coded total and  $T_s$  = summed total.

This resulted in both positive answers (if the summed total was less than the coded total) and negative answers (vice versa). Table 5.1 shows the distribution of these errors (no errors occurred for the years 1951, 1961 or 1971 as the figures are calculated by OPCS and sum to county totals) and, from this, different types of error may be determined.

The first type represents those which are not actually errors in the coding at all. Some boundary changes involve inter-county movements of population. When encoding county totals, an effort was made to adjust these for county gains or losses (see section 4.3.1). However, if the numbers of people involved were very small, then the adjustment was not always made. It is interesting to note that all the errors falling above/below  $\pm 0.3\%$  belong to just six counties: West Yorkshire (2), Hertfordshire, Gloucestershire (2), Warwickshire, Worcestershire and Staffordshire. In each case there have been a number of very small cross-county movements usually due to large cities lying on the boundary. Sheffield (West Yorkshire), for example, gained population from surrounding Derbyshire by these means on a number of occasions. Also included in West Yorkshire is the city of York, which expanded over the time period into both the East and North Ridings of Yorkshire. Hertfordshire, on the one hand, gained Potters Bar from Middlesex and, on the other, lost the Barnet area to the GLC. Finally, the remaining four counties

Table 5.1: Errors.

1) England and Wales.

<u>% Error (+/-)</u>	<u>1901</u>	<u>1911</u>	<u>1921</u>	<u>1931</u>	<u>1939</u>
>/< 0.3	0/2	2/2	0/1	0/1	-
0.2 → 0.29	5/2	6/0	0/1	0/1	0/1
0.1 → 0.19	7/1	4/2	-	-	1/1
0.01 → 0.09	6/4	6/6	4/3	3/5	7/4
>/< 0.01	4/3	4/3	5/3	4/1	4/1
<b>Total, E &amp; W</b>	<b>22/12</b>	<b>22/13</b>	<b>9/8</b>	<b>7/8</b>	<b>12/7</b>

2) Scotland.

0.1 → 0.19	1/1	2/1	1/1	2/0
0.01 → 0.09	6/1	5/0	1/1	2/2
>/< 0.01	3/3	8/3	0/3	0/1
<b>Total, Scot.</b>	<b>10/5</b>	<b>15/4</b>	<b>2/5</b>	<b>4/3</b>

<b>Total, GB</b>	<b>32/17</b>	<b>37/17</b>	<b>11/13</b>	<b>11/11</b>	<b>12/7</b>
------------------	--------------	--------------	--------------	--------------	-------------

+ / - Error.

Source: Calculated from basic data.

show considerable change amongst themselves. Birmingham, lying on the Warwickshire / Staffordshire border, has on numerous occasions gained parts of the latter. Similarly, Dudley (in Staffordshire), Bromsgrove (in Warwickshire) and Smethwick (in Worcestershire) have either been 'moved' from, or expanded into and 'taken' parts of Worcestershire (twice) and Staffordshire respectively. There have been numerous (primarily rural) inter-county movements between Gloucestershire and Worcestershire, and also between Gloucestershire and Somerset (due to the expansion of Bristol). They should not therefore be regarded as serious errors.

The second class of error is that which is undoubtedly genuine, due to mistakes in coding and / or calculation. These are often small errors of about 0.1 to 0.2%, and examination of table 5.1 shows that these occur during the years 1901 and 1911, the data on which most calculations had to be performed owing to the numerous boundary changes resulting from the County Review Orders. If time permitted, most of these errors could probably be removed; however, it takes several hours to trace even the simplest of these and they were sufficiently small to disregard them. It must also be remembered that even at 0.4% the absolute numbers of people involved are usually very small. One of the largest counties, West Yorkshire, has the largest error of the whole study at +0.4% for 1911. This represents an excess of 12,790 people on a coded total of 3,152,551. In Leicestershire, at 1921, an error of +0.28% represents an excess of 1,374 people

on a coded total of 437,490. This class of error was termed inherent error.

The third class of error is that of less than 0.1%; these are rounding errors incurred during calculation. They originate primarily from the division of 'dead' areas where, theoretically, the sum of the parts percentaged should equal 100. However, area transfers were only recorded if they represented a movement of greater than 1% of either the source (parent) population, or of the sink population. Thus if several transfers, each of less than 1% occurred, a certain number of people would be 'lost' from the area. A rule was applied then that not less than 98% of each 'dead' area had to be accounted for, as a safeguard against this happening on too large a scale. In the occasional cases where the total represented less than 98%, a 1% transfer was awarded to the area gaining less than 1% in order of magnitude, until 98% was reached. This occurred on very few (less than ten) occasions throughout the entire time period, and the numbers of people affected are very small.

In all calculations, whole numbers were used; any fraction less than 0.5 was rounded down, and those greater than or equal to 0.5 rounded up. Thus, even if all the population were accounted for in splitting up dead areas, calculations could still result in totals of 99 or 101 due to rounding. This then was a further source of error, but only a very small one. Examination of table 5.1 shows a pairing of errors for the years 1901 and 1911, and again for the years 1921 and 1931, the number

of positive and of negative errors for each set being almost identical. This would suggest that rounding errors, especially in the splitting of dead areas, are predominant; such errors being applied to data of both years would occur twice, whereas a simple error of miscalculation is unlikely to affect both pairs of figures. All forms of rounding errors are otherwise termed allocation errors, since they result in the mis-allocation of persons between two or more districts.

A simple means of comparison was also used to check the accuracy of the figures derived from the second stage of calculation, the 1901 to 1971 data by post-1974/5 areas (see sections 4.3.3 and 4.3.4). At this stage, checking was carried out to verify the contents of the table used to determine the codes of the old areas constituting the new ones; a simple typing error altering any one of the old area codes could have disastrous effects. The control data used were the actual population figures for 1971 as listed in the 1974 (1) census volumes. (These had been encoded by the author some time previously and were also available on the computer.) The calculated 1971 population figures for the new areas were then compared against these; if the difference between the two represented over 1% of the correct (OPCS) figure then in all cases, an error had occurred in the encoding of the old area codes. Unless a new area represented a whole amalgamation of old areas, a perfect match could not be expected to occur, owing to

---

1 See note on page 7.

rounding (allocation error). The percentage of the population of a split old area was always rounded by OPCS for England and Wales, and by the author for Scotland, to the nearest integer. Thus small errors could arise in this way, although never greater than 1% of the final figure, and, theoretically, not greater than 1% of the population of the split area. For simplicity, 1% of the final figure was used as a check.

Errors may be viewed as a mis-match of the summed and coded totals, and generally corrected. However, even if no errors (as outlined above) have occurred in the calculations, figures can emerge which appear substantially higher or lower the expected result when viewed in time series. There are a number of possible reasons for this, which are advanced below.

First, the method of calculating the number of people moved as a result of boundary changes can lead to errors. The figure is simply expressed as a percentage of the population of the entire area and makes the assumption that the distribution of population within the source area does not change through time. Clearly this is not always the case; considerable inhomogeneity exists within most local authority areas, except those at the rural or urban extremes. The greatest problems occur with rural areas bounding urban authorities of rapid growth. At early censuses, the rural area is likely to be fairly evenly populated at a low density. However, as the urban area encroaches upon the surrounding countryside, parts of the rural area will increase in population, producing marked variations in population density

within that rural area. It is usually the case that amalgamation with the urban area is made after the period of urbanisation rather than before, thus the ratio of the number of people moved to the population of the area as a whole is not the same as that at the censuses prior to urban expansion, although it is assumed to be so. This leads to an underestimation of the population of rural areas, and an overestimation in urban areas at earlier censuses - a ratio error. To overcome this problem, it was originally intended to calculate boundary changes at a finer spatial resolution.

At each English and Welsh census, the number of people transferred by a boundary change is broken down to civil parish level and then summed to give the total number of people lost or gained at local authority level. Working at the civil parish level, population movements can be pin-pointed very accurately, and, indeed, the first county to be coded (Norfolk) was done at this level. It was then realised that working at this level was increasing the number of calculations considerably (in the case of Norfolk, some twenty-fold). Also, although the smallest unit recorded in the English and Welsh census is the civil parish, the introduction of county council electoral districts in Scotland meant that the civil parish was not used by GRO(S) to describe boundary changes after the census of 1951. Here, also, boundary changes are not detailed to as great a level as in England and Wales. For these reasons, and despite a loss in accuracy, it was decided to work only at local authority level. The following

example illustrates the problem and results.

Leicester CB was bordered by, amongst other areas, Billesdon RD and Blaby RD. The rapid expansion of Leicester during the 1950s and 1960s resulted in the passing of the Leicester Order in 1966, and the subsequent transfer of 9,624 and 5,955 people to Leicester CB from Billesdon and Blaby RDs respectively, leaving just 8,651 and 50,469 people in each area, respectively. The origins of the transferred population in both cases were civil parishes immediately contiguous with Leicester CB and which exhibited abnormal growth rates, far in excess of those found throughout the rest of the rural areas. The number of people moved represents 53/11% (1) of the entire rural district as at 1961. However, as a percentage of the population of the civil parishes from which they originate, the corresponding figure is 77/18%. Applying these percentages to the 1921 figures, then, gives the following results:

	<u>Billesdon RD</u>	<u>Blaby RD</u>
1921 population (actual)	5335	18964
53/11% of entire area -	2828	2086
therefore remainder =	2507	16878
77/18% of civil parishes -	514	489
therefore remainder =	4821	18475

For 1931:

1931 population (actual)	5901	25840
53/11% of entire area -	3128	2842
therefore remainder =	2773	22998
77/11% of civil parishes -	870	1353
therefore remainder =	5031	24487

---

1 In all cases the first figure represents the percentage for Billesdon, and the second the percentage for Blaby.

When viewed in time series, the measure of difference in the results becomes apparent:

Calculated from the civil parish:

	<u>1921</u>	<u>1931</u>	<u>1951</u>	<u>1961</u>	<u>1971</u>
Billesdon RD	4821	5031	7022	8651	11124
Blaby RD	18475	24487	38688	50539	74242
Leicester CB	238696	259941	285626	288065	284208

Calculated from the district:

	<u>1921</u>	<u>1931</u>	<u>1951</u>	<u>1961</u>	<u>1971</u>
Billesdon RD	2507	2773	7022	8651	11124
Blaby RD	16878	22998	38688	50539	74242
Leicester CB	242607	263688	285626	288065	284208

The method adopted results in a marked underestimation of rural areas in favour of urban areas, and a much faster rate of apparent growth in rural districts between 1931 and 1951.

Ratio error also occurs with New Towns. If the New Town was designated an independent local authority before the period of study began (i.e., before 1901), then no problems arise; the figures are simply encoded taking into account any boundary changes. However, if the local authority was created as a new area between 1901 and 1971, then problems may arise. In some cases, the area is created before any major population growth occurs, therefore the ratio of the number of people in the new area to the number of people in the parent area is representative of the true situation and its use at previous censuses provides a comparatively accurate picture of the population distribution.

Table 5.2 illustrates the population of Welwyn Garden City, Herts., Corby, Northants., and Washington, Co. Durham. Declared as independent urban districts in 1927, 1939 and 1927 respectively, they were not designated as New Towns until 1946, 1948 and 1962. The population calculated for each area at all censuses prior to their formation would seem acceptable.

At the other extreme are New Towns designated as such before becoming independent local authority areas. Here population growth has occurred and the resulting percentage calculation does not give an accurate picture. In some cases the results are not badly out of alignment - Thurrock UD (which encloses the greater part of Basildon New Town) and Cumbernauld SB all show figures which seem to be greater than expected in earlier years, but not serious enough to warrant altering the basic method of calculation.

In two cases, however, the results were so obviously wrong that it was necessary to devise a different method for calculation of the population as at previous censuses. These are the New Towns of East Kilbride, Lanarkshire, and Glenrothes, Fife, designated as such in 1946 and 1947. They were not, however, created as independent local authorities from their parent bodies (No.5 DC, Lanarkshire, and Kirkcaldy DC) until 1963 and 1966 respectively; in the interim period considerable population growth had already occurred. If calculated by the conventional methods used elsewhere, the population of the two areas at the previous censuses is found to be as follows:

Table 5.2: Population of selected New Towns, 1901 - 1971.

NEW TOWN	POPULATION							
	1901	1911	1921	1931	1939	1951	1961	1971
Welwyn G.C. UD, Herts.	1797	1960	1071	8937	17142	18804	35179	40488
Corby UD Northants.	1604	1733	1743	1770	1754	16905	36101	47994
Washington UD, Durham	11711	15330	17721	17704	16952	17879	18850	24057
Thurrock UD, Essex *	43503	53057	48751	61644	63431	82108	114263	125088
Cumbernauld SB Dunbart.	4141	4573	4071	4242	n.a.	3137	5162	31784

\* includes Basildon New Town.

All figures inclusive of population lost/gained as a result of boundary changes.

Source: See Appendix C.

	<u>1921</u>	<u>1931</u>	<u>1951</u>	<u>1961</u>	<u>1971</u>
East Kilbride	14198	13811	4587	31439	63502
Glenrothes	7666	7293	1519	12425	27135

The 1951 and 1961 figures relate to the area as defined in 1971, and were reaggregated before their publication by the GRO(S). These figures are obviously not representative of the true situation, and the areas were therefore recalculated on the basis of the 1951 distribution of the population. The population of each new area as determined by the GRO(S) for 1951 was taken as a percentage of the source area as at 1951, resulting in the following data:

	<u>1921</u>	<u>1931</u>	<u>1951</u>	<u>1961</u>	<u>1971</u>
East Kilbride	4351	4232	4587	31439	63502
Glenrothes	1677	1594	1519	12585	27135

These would appear to constitute a better estimate of the population prior to 1951. Only on these two occasions was a departure made from the procedure outlined earlier in the chapter; all other calculations were made according to that method.

On very rare occasions the reverse of this problem of transferring already developed areas and its effects on previous years data can occur. During a survey of planning officers carried out to test the accuracy of the derived data set (and described in section 5.2), Castle (1980, pers.comm.)<sup>1</sup> revealed this to be the case in rural areas in Shropshire. Here certain parishes with a very rapidly declining agricultural population

1. K. Castle. Shropshire County Council.

have been transferred to surrounding local government areas. The number of people 'moved' at the time of the boundary change represented a lower proportion of the total area's population than at any census previously. Hence the population of the source area has at all times been calculated to be too high, and that of the sink area too low. It is not known how widespread is this problem. However, given the general stability of boundaries between rural areas (most changes being rural-to-urban transfers), it is unlikely to be severe, and the total number of people involved must be very small in view of the low population densities generally encountered within rural areas.

A partial solution to these problems of mis-representation of the population of areas at earlier censuses is shown by Morrey (1973) in his work on the population of the London Boroughs throughout the 20th century. Like this author, he utilises a direct proportion approach in accounting for changes in boundary; however, his percentages are derived from the population totals at the census, two previous to the one in which the boundary change occurred and not one previous as the author used, thus minimising the chance of basing the calculations on urban developments which have already occurred.

More specifically, the method used by the author and given in section 4.3 is summarised as

$$\frac{P(n-3)x}{P(n-3)X} = \frac{P(n-2)x}{P(n-2)X} = \frac{P(n-1)x}{P(n-1)X}$$

where P = population at time n  
and x = part of area X transferred  
n = present census year

To illustrate this, reference should be made to the example on page 126.  $P(n-1)x$  is the population of the area transferred as at the previous census, which is given in the census volume following the change - i.e. in 1961, some 1,283 persons were resident in the area of Guisborough UD transferred to Teesside CB, a figure listed in the 1971 census volume.  $P(n-1)X$  is obtained from the previous census volume and indicates the actual population of the entire unaltered area - 12,079 persons for Guisborough UD in 1961. The author assumes that at any previous census year, the ratio of the number of persons in the area transferred (1,283) to the number of persons in the source area (12,079) remains constant (in this case 11%), an assumption shown above not always to be valid (resulting in ratio error).

The method utilised by Morrey in his calculation of the population of the London boroughs from 1901 to 1971 does not assume the distribution of the population over the source area to be constant through time - i.e., the percentage of the total population resident in the area transferred, at the census immediately prior to the boundary change, is not equal to the percentage resident in that area at earlier censuses -  $P(n-2)x/P(n-2)X$  is not equal to  $P(n-1)x/P(n-1)X$ . Morrey

calculates his 'percentage' using data from the census two previous to the current one (in the above example he would use the 1951 population of Guisborough UD transferred, to the 1951 population of the entire unaltered area, rather than 1961). The justification for this is that most changes in boundary follow rapid urban development. Thus, the use of the 1951 instead of the 1961 figure lessens the chances of moving a disproportionate number of people from the source to the sink area.

The population of the area transferred for the second previous census (i.e.,  $P(n-2)x$ ) is not given in the census volumes, but can be determined in some cases. Each county volume records the total population of the area as defined for the present year and for two censuses previously (i.e.,  $P_nX$ ,  $P(n-1)X$  and  $P(n-2)X$  or, in the above example, the 1971, 1961 and 1951 population of Guisborough UD as spatially defined in 1971). The previous county census volume (that before the boundary change occurred) also gives the three sets of figures for the 'unaltered' area (i.e. the 1961, 1951 and 1931 population of Guisborough UD as spatially defined in 1961). Thus simple subtraction reveals the population of the actual area transferred. The following is used as an example by Morrey:

From the 1931 census volume for Middlesex we can establish

Date of change: 1 - 10 - 1928

Area diminished: Uxbridge RD

Area enlarged: Harrow on the Hill UD.

Population of Uxbridge transferred to Harrow as at the 1921 census : 168

	<u>1901</u>	<u>1911</u>	<u>1921</u>	<u>1931</u>
Population of Harrow (1931 area)	(b)	17202	19637	26380

From the 1921 census volume for Middlesex we can establish

Population of Harrow (1921 area)	10220	17074	19469	-
Difference	(a)	128	168	-
Population of Uxbridge RD (abolished 1928, remainder to Uxbridge UD and Enfield UD).	7845	9240	10643	-

Thus  $P(n-2)x = 128$  and  $P(n-1)x = 168$

$P(n-1)X = 10643$

In the absence of  $P(n-2)x$  (128), this author would base her calculation of the 1901 population of the area of Uxbridge transferred to Harrow ( $P(n-3)x$ ) on the population distribution as in 1931 - i.e.

$$\text{or } \left[ \frac{P(n-1)x}{P(n-1)X} \right] * P(n-3)X$$

$$\left[ \frac{168}{10643} \right] * 7845 = 123$$

The 1901 population of Harrow as determined by the author is then

$$10220 + 123 = 10343$$

Morrey, by subtraction, is able to determine  $P(n-2)x$  as 128.

Therefore he can base his calculation of the 1901 population on the 1921 distribution i.e.

$$P(n-3)x = \frac{P(n-2)x}{P(n-2)x} * P(n-3)x$$

or

$$\frac{128}{9240} * 7845 = 109$$

The 1901 population of Harrow as determined by Morrey is then

$$10220 + 109 = 10329$$

The above then illustrates the overestimation of the population of urban areas as a result of using  $P(n-1)x/P(n-1)x$  as a multiplier. The difference in this case is small: the reason for this boundary change was simply to abolish an anomalous rural district in Middlesex, long since developed. Had rapid urban development actually taken place (and thus the figure 168 been much larger), the discrepancy would have been greater.

Although in theory a better estimate of the population, there is one major flaw in Morrey's method. If an area has received population from only one area at one time over the inter-censal period, then  $P(n-2)x$  can be determined by simple subtraction. However, if the population added to the area originated from more than one area or at more than one time, it is not possible to calculate  $P(n-2)x$  by source area - subtraction will only reveal the total population added to the sink area. It is for this reason the example was changed from Guisborough UD to Uxbridge RD. Teesside CB (the sink area for Guisborough UD) received population from nine different places and it is not possible to isolate the individual Guisborough component. Hence the author's

method has to be used as at (n-1),  $P(n-1)x$  is given in the census volume for each constituent source area (and is assumed to be correct).

A second problem within the data set - for which correction is impossible - has quite marked effects on the study of change in population. This is the alteration of the date of the 1921 census. Every other census this century, with that one exception, has been held in April (see table 5.3). The 1921 census, being held in June, fell within a marked holiday period. Whilst this is not reflected in the returns of most local authorities, certain popular holiday resorts show vastly inflated totals as is shown in table 5.4.

A third problem occurs with the use of population figures originating from the 1939 National Registration of the population, as outlined in section 4.3.1 and illustrated in table 4.7 (page 132). During coding it became apparent that many figures appeared to be out of step with the general trend shown by census data. The reasons for this feature have since been ascertained.

It seems that the National Registration figures represent the civilian population only (Knight, 1980, pers.comm.)<sup>1</sup>. Furthermore, both before and after the National Registration, from which the figures are derived, was set up (September 1939), evacuation had already altered the population distribution in the country quite considerably, and accurate estimation of this has

---

1. S. Knight. Dep't of the Environment.

Table 5.3: Census dates, 1901 - 1971.

---

<u>Year</u>	<u>Date of census</u>
1901	March 31 / April 1
1911	April 2 / 3
1921	June 19 / 20
1931	April 26 / 27
1951	April 8 / 9
1961	April 23 / 24
1971	April 25 / 26

Source: See Appendix C.

---

Table 5.4: Population of selected holiday resorts, 1901-39.

---

	<u>1901</u>	<u>1911</u>	<u>1921</u>	<u>1931</u>	<u>1939</u>
Eastbourne, East Sussex	44527	53608	63126	58644	69748
Ilfracombe, Devon	8557	8935	11772	9175	9407
Hunstanton, Norfolk	2376	3043	5003	3132	3585
Mablethorpe, Lincs.	3126	3461	4916	3928	4575
Bridlington, E. Yorkshire	13238	15090	23540	20194	25429
North Berwick, E. Lothian	2902	3246	4794	3683	n.a.
Arran, Bute	4837	4628	8294	4532	n.a.
Llandudno, Carnarvonshire	10647	12010	21048	15703	17595

Source: See Appendix C.

---

proved to be extremely difficult. Lastly, part of the registration procedure was based on the distribution of ration books which, not surprisingly, resulted in some very faulty information. Figure 5.1 illustrates the population of the post-1974 counties of Tyne and Wear and of Avon, as determined during this research. The marked difference in the 1939 data is illustrated very clearly. During the survey of planning officers held to test the accuracy of the data set (see section 5.2), it was suggested that instead of the National Registration of 1939, the mid-year estimates of the same year should have been used. However, this would not have solved the problem entirely since armed forces are estimated at their stations (see section 4.2.1) and this in itself would have introduced a large amount of distortion. This was in fact the solution adopted by Morrey (1973) in his attempt to derive the populations of the post-1966 London boroughs back to 1901. Within the GLC, the National Registration figures so mis-represent peacetime conditions (see the dashed line for selected areas graphed on figure 5.2) that the 1939 GLC data in the author's data set was amended to equal that presented by Morrey (and graphed a solid line on figure 5.2). This could have been done for the whole country; however, elsewhere the effect on this data set (especially outside the largest conurbations) is rather less marked and it was not considered worth amending the figures for the vast number of old local authority areas (especially since the mid-year estimates would have to be adjusted for all post-1939 boundary changes).

**Figure 5.1: Population of Tyne and Wear, and Avon, 1901 - 1971.**

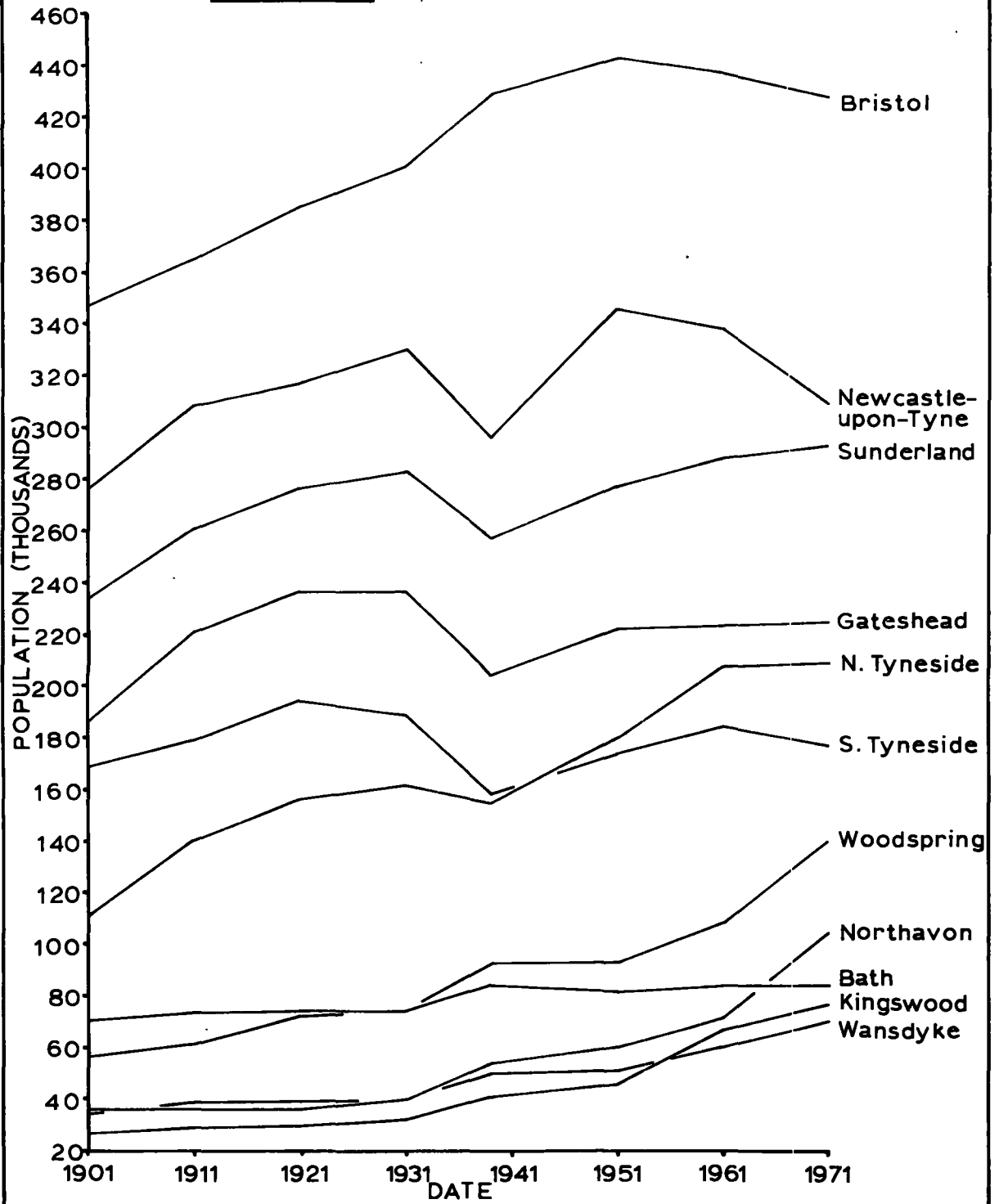

**Figure 5.2: Population of selected London Boroughs, 1901-1971.**

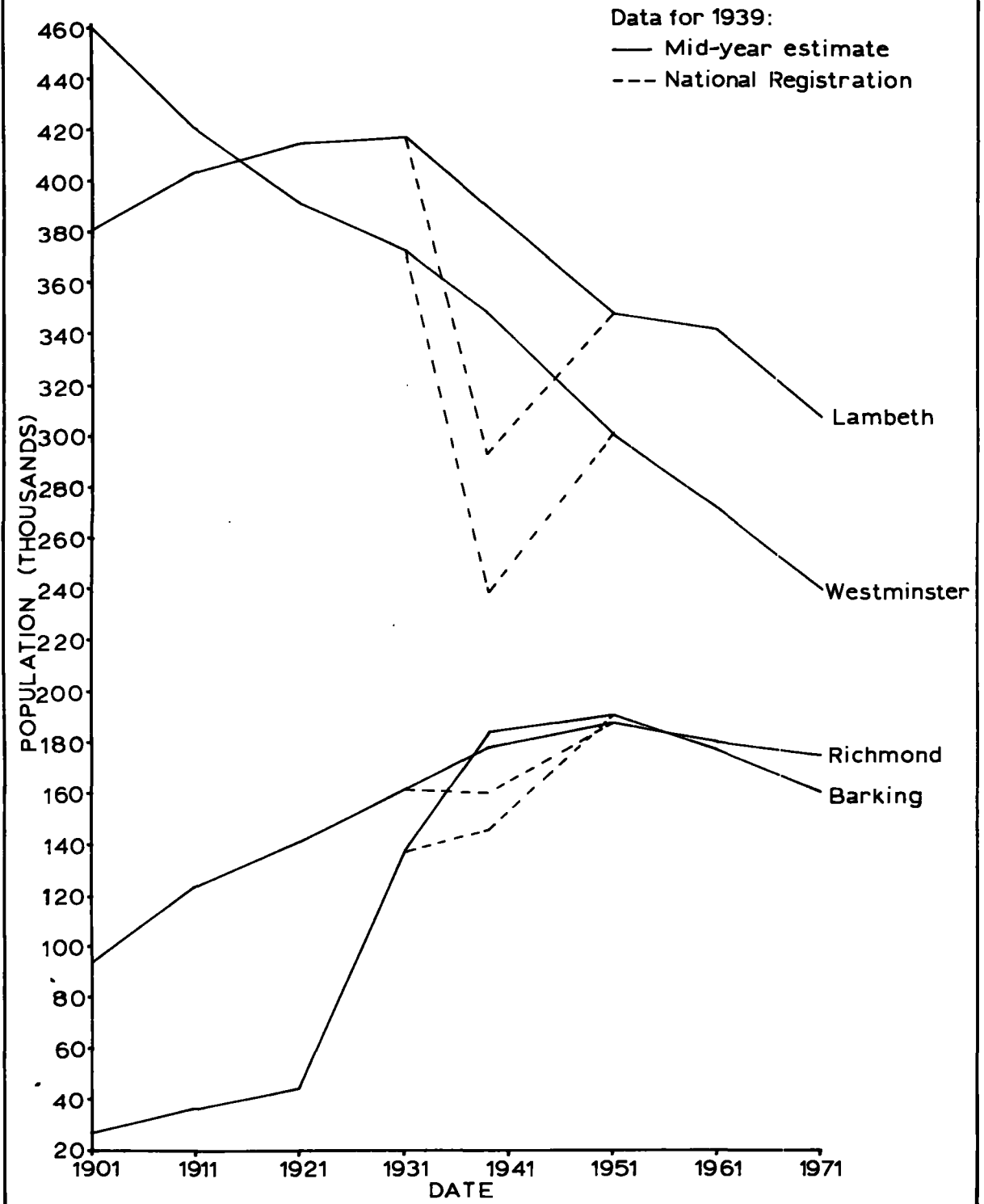

A final problem is that encountered in Scottish data for the years 1901 and 1911 only. As described earlier, an estimate of the division of the population of landward areas into districts was made by taking the distribution as at 1931 as a guide. The 1931 rather than the 1921 distribution was chosen simply because of the June date of the earlier census and inaccuracies introduced through that. After 1911, many burghs gained parts of the landward areas through boundary changes. Thus, part of the landward population as at 1901 and 1911 should have in fact been burghal, in accordance with the aim of estimating the population of the area as at 1971. Because the actual breakdown of landward population into districts was not known, it was not therefore possible to 'move' a percentage of any particular district to the burgh. The net result is that the burghal population is too low and the landward population in every district is too high. It would be possible, having divided the population to districts, to move the relevant percentage of any district exhibiting change to the burgh but, even then, the population of any unchanged district (of which there are a great many) would still be too great, and the numbers transferred too small. This problem is reflected particularly in the districts surrounding the four cities of Aberdeen, Dundee, Edinburgh and Glasgow, and is shown by table 5.5.

The problem could be solved by use of the civil parish. However, as with the use of the civil parish in England and Wales (see above), the amount of work involved would not, in the great

Table 5.5: Population of selected county districts, 1901-51.

---

	<u>1901</u>	<u>1911</u>	<u>1921</u>	<u>1931</u>	<u>1951</u>
Aberdeen DC, Aberdeen	25793	24795	21210	21873	25709
Monifieth DC, Angus	8716	8358	7916	7311	7612
Lasswade DC, Midlothian	7219	8123	5014	5534	6545
Musselburgh DC, Midlothian	6103	6868	5087	4671	6473
No.8 DC, Lanark	48154	60955	39050	44704	56137
First DC, Renfrew	19460	27553	12700	17238	38201

Source: See Appendix C.

---

majority of areas, justify the results.

At this stage then, errors had been removed from the data set and known inaccuracies identified. Checks had been performed to ascertain the feasibility and consistency of the data, but it was not possible to determine how accurately the results represent the population distribution at any one time. The ultimate solution to this problem would be to reaggregate the population data from the enumerators' handbooks to the new areas; obviously this is out of the question, not only because of the enormity of the task involved, but also because the original records are confidential for 100 years. Hence only a partial solution was available and was adopted - a survey of all 458 district planning officers in England and Wales, and Scotland. This is now described.

## 5.2 A SURVEY OF PLANNING OFFICERS

In order to conduct such a survey, each planning officer was sent by post a letter explaining the aims and objectives of the study, a computer printout of the post-dicted population for that area and for all contiguous local authorities at each date, and a note on how the post-dictions were carried out. The planning officers were asked to comment on the enclosed data, outline any local factors which may have rendered the assumptions false, and

(if this were the case) to indicate a likely population for the area at the time. An outline of the methodology (basically a precis of section 4.3) formed the main text of the accompanying note, together with an appendix listing the sources of data used. The population figures supplied were those for the local authority in question and for all contiguous local authorities - the justification for this being that if a massive error had occurred, it was likely that a corresponding and cancelling error would occur in a contiguous area. Contiguous areas were determined from the file of boundary sections described in section 5.5. Each boundary section has associated with it two area codes defining the right- and left-hand polygons. The codes (without the accompanying section co-ordinates) were read. Duplicate pairs of codes arising from polygons which border each other in two or more separate places were removed, as were those pairs of codes in which one represented the sea. The entire file of pairs was then duplicated once, each pair being reversed in the process - as area A borders area B, area B borders area A. The entire file was then sorted, reformatted and used to match up to area names (stored in a separate file) and area population figures, resulting in a printout as shown in figure 5.3.

The response from the above survey was encouraging. Some 219 district planning officers replied, together with 12 county planning officers. Although the latter were not surveyed initially, some smaller districts rely entirely on the parent county councils for specialist advice and research facilities and

Figure 5.3: Example printout for survey of Planning Officers

ESTIMATED POPULATION OF MANCHESTER

AND SURROUNDING AREAS, 1901-1971.

	1901 -----	1911 -----	1921 -----	1931 -----	1939 -----	1951 -----	1961 -----	1971 -----
MANCHESTER	649617	719787	735764	766412	622005	703194	661964	543852
SURROUNDING AREAS:								
MACCLESFIELD	77747	81158	80139	85593	97954	99207	112357	139975
RUCMDALE	163028	170621	175941	176881	168197	170702	189834	203133
SALFORD	307952	334175	343265	338843	287443	305853	294385	279892
OLDHAM	228439	248178	249097	240793	219831	221300	215669	223970
TRAFFORD	96071	121675	129320	155717	186375	205565	224162	227884
TAMESIDE	190516	197384	193106	189726	198639	204733	204232	220856
STOCKPORT	134416	156869	165495	180936	217458	223726	256002	292256
BURY	126914	133689	132125	138150	147421	151415	152297	174542

PLEASE SEE ACCOMPANYING NOTE FOR METHOD OF CALCULATION OF FIGURES.

so passed the survey on to them. The 12 county councils represent (in total) 67 district councils; thus replies were received directly and indirectly from some 286 districts. These are shown in figure 5.4; areal coverage of the replies is seen to be good.

Of the replies received, five districts declined to comment citing as their reason the shortages of staff to deal with such non-essential matters as a result of recent cutbacks in local government expenditure. A further two districts declined to comment as they were unable to see the point of such a survey especially in terms of benefit to themselves. The remaining 212 replies were, without exception, favourable. Whilst none could say conclusively that for 1901 to 1931 the figures were right or wrong, all thought them to be a fair estimate. Doubts were frequently expressed about the 1939 data (which were later dropped) for the reasons outlined in section 5.1.

A large number of districts provided their own figures for the population at various dates, especially for the years 1951, 1961 and 1971, as this data are readily available having been reaggregated by OPCS. Unless the post-1974 districts are whole amalgamations of pre-1974 areas, discrepancies between the OPCS figure and the calculated figure are bound to arise as outlined in section 5.1 and, whilst many planning officers were quick to point out such 'faults' in the data, none appreciated the cause of them. With one exception, none of the data supplied by planning officers was substituted for the calculated data. This

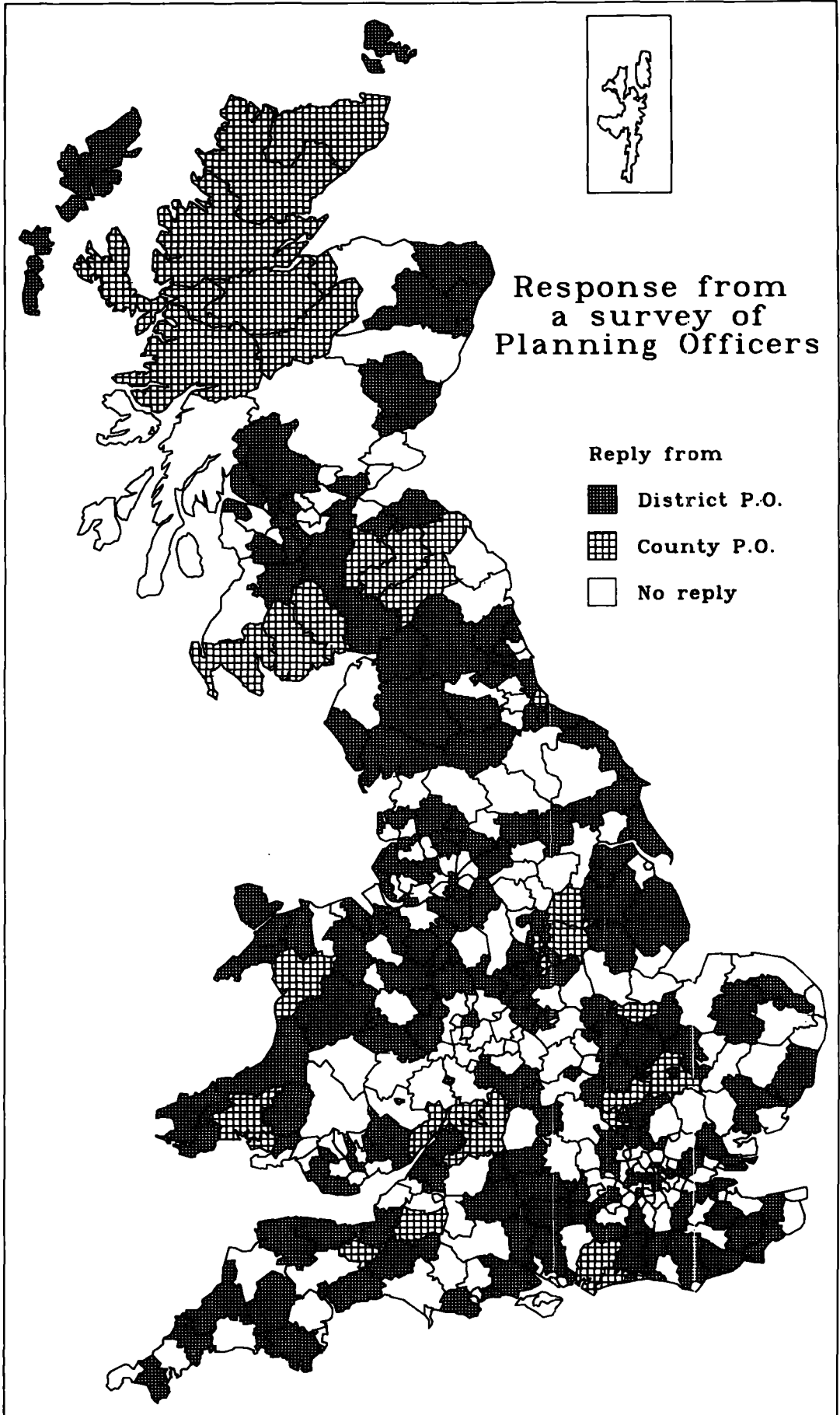

Figure 5.4

was primarily due to a lack of consistency; planning office data originated from a large number of sources including county structure plans, Electoral Register based surveys and a simple reaggregation of constituent parishes whose population was that recorded at the census. In some cases, the source of planning office data was unspecified. Whilst the author does not doubt that some planning office data is a more accurate estimation of the population than that calculated, it would be erroneous to apply such a haphazard set of corrections to what is at least a consistent (if not entirely accurate) data set.

As mentioned above, one change to the data set was made as a result of the survey. During the early 1930s, as a result of a County Review Order (see section 4.1.1), a large number of boundary changes occurred throughout rural Cambridgeshire. The planning officer for the City of Cambridge was able to demonstrate quite conclusively a misallocation of population between the present districts of South Cambridgeshire and the City of Cambridge which originated at that reorganisation, and provided corrected figures. These were the only data changed in the author's data set; at this stage the remaining figures were as originally calculated.

Further points raised (in a descending order of frequency) are now examined. First, a large number of planning officers questioned the actual methodology in that it produces an overestimate in urban areas, and an underestimate in rural areas at years preceding a change in boundary. The reasons for this

are outlined in section 5.1. Many only questioned and were unable to provide examples; however, a few planning officers cited population figures in order to demonstrate the weakness of the method. An example provided by the planning officer for the new district of Kingston upon Hull is most spectacular. In 1967, development of a council housing estate in an area north of Hull and in Beverley RD was begun. Following a change in boundary in 1968, the area became part of Hull CB, involving a movement of 1,770 persons. Using the percentage multiplier method, the author calculated the corresponding figures for 1921 and 1931 as 713 and 709 respectively. However, the movement of population into the new estate was monitored by the Clerk to Beverley RDC, who was then able to provide figures for the actual population of the area as only 220 in April, 1967, 403 in May, 1967 and then 1,770 at the change of boundary in April 1968. This clearly demonstrates the limitations of the author's method (although it is believed to be an unusual example). In such cases the imbalance of population is often redressed by the aggregation of rural and urban areas to form a new (larger) post-1974 district, but this did not occur here. Hull CB remained unchanged as a new district, and Beverley RD was amalgamated with Beverley MB and Haltemprice UD to the new district of Beverley. Thus the imbalance of population still remains within the data set.

A number of planning officers from Scottish districts were critical of the method used to determine the 1901 and 1911 population of the districts of county from the landward areas.

The stability of Scottish civil parish boundaries was demonstrated and several districts provided population data back to 1901 based on a simple amalgamation of parishes. This was not used as it was not available for all areas.

Seven planning officers raised the problem of the location of armed forces bases within their areas and two (Yeovil and Winchester) were concerned that they may have been in areas affected by a boundary change. The regional planning officer for Highland RC noted that the population for the district of Nairn in 1971 included some 2,709 members of HM Forces enumerated on board the Ark Royal stationed off-shore on census night and that it should be reduced accordingly. This suggestion was not carried out as a) it is impossible to assign them elsewhere, and b) other districts will also include such discrepancies. The planning officer for the City of Winchester was able to provide figures for the numbers of military personnel in the district on certain census nights; in 1911 this was as high as 4,016 - 10.7% of the total population of the district.

Two district planning officers claimed errors in the list of contiguous districts, which in turn reflects upon the original boundary data used to generate these lists. The planning officer for Hamilton (Strathclyde) thought his district bordered that of Monklands. Examination of an OS 1:625,000 map of post-1974/5 administrative areas proves this not to be the case. The planning officer for Rushcliffe, Notts. reported his area to be contiguous with Broxtowe which was not on the printout received.

Examination of the above OS map indeed showed a boundary of about 3 km in length. Such a boundary is not included in Baxter's (1976) original segment file and hence is missing from the list of contiguous districts despite being approximately ten times the length of the minimum boundary section (see table 5.6, page 196).

Two district planning officers made impractical suggestions. First, the planning officer for Aberconwy DC suggested that boundary changes should be accounted for at an Enumeration District level, instead of using crude population to area assumptions. However, published Enumeration District data are a development of the 1961 Census but the study goes back to 1901. Furthermore, boundary changes have never been published to a greater level of detail than that of civil parishes, and no amount of computational power could do the initial calculation and encoding of boundary changes from the census volumes, irrespective of level and the actual number of changes involved.

The planning officer for Sefton quotes

'once the system is computerised it would be merely a question of feeding in additional data to give output by age / sex groups'. (1)

The author does not consider this to be a practical suggestion. The amount of additional data required would be extremely large as the age / sex structure of the British population is variable both through time and over space.

---

1 D. Barnett, 1980, pers.comm. Sefton Metropolitan District Council.

Overall, the results of the survey were very favourable, although doubtless many planning officers formulated their opinions on imperfect or incomplete knowledge of the process and problems involved. As a final test, details of the methodology involved were sent to OPCS for criticism. The following constitutes part of the reply received.

'The paper is interesting and the method gives good approximations to the populations concerned. Provided the limitations recognised by the author were made clear in explanatory notes, the figures would seem worthy of wider circulation as they fill a gap in our publication programme. We do not have District level counts nor could we see them being produced'. (1)

The comments of both OPCS and all the planning officers who replied to the survey seem to validate the accuracy of the data as representative of their areas. OPCS suggested the data be controlled to the (new) county level populations as reaggregated by themselves and published in the 1974 county census reports. This suggestion was adopted and is now discussed.

### 5.3 ERROR CHECKING: THE SECOND STAGE

The survey of planning officers described in section 5.2 provided a subjective check on the accuracy of the data: using county population totals calculated by OPCS it was possible to perform a final test on the data set, this time to give some

---

1 C. Denham, 1980, pers. comm. OPCS.

objective results with regard to its accuracy. (1)

Table 2 of each 1974 county census report lists the population of that county (as spatially defined in 1974) at each census since 1801 and also at 1939 (based on the mid-year estimates of that year). To produce this data, OPCS employed a method not entirely dissimilar to that used in this research, but applied at a county - instead of district - level.

The major difference in the method used by OPCS and by the author was that the former reaggregated old local authorities directly to new counties, instead of aggregating first to old authorities as at 1971 and then to new counties - a two stage process. Against the use of the author's two-stage process is that she calculated what were in effect redundant boundary changes between areas subsequently amalgamated in 1974. For instance, in determining the population for 1931 and earlier of Durham RD and Durham MB as spatially defined in 1971, she had to take into account a change in boundary which resulted from the Durham County Review Order of 1937, and transferred part of the former area to the latter. If the author had omitted the stage of calculating to a 1971 base and aggregated directly to a 1974 base then the calculations for this change in boundary would have been unnecessary as the two areas were wholly amalgamated (along with Brandon and Byshottles UD) to the new district of Durham in 1974.

---

1 The test was also carried out for Scotland; for '1974' census volumes substitute '1975', and for 'OPCS', substitute 'GRO(S)'.

In support of the author's two-stage process (as opposed to the more direct one-stage process as employed by OPCS) is the fact that many old local authority areas were actually stable in boundary from the mid-1930s (after the implementation of the County Review Orders) to 1971. It was easier then to code the population of these areas (as they were already on a 1971 base) and then perform the reaggregation to the 1974 areas for the entire period from 1901 to 1971 by computer as a second stage, rather than incorporate such a reaggregation by hand throughout the coding process (as was, in effect, done for the GLC as a result of the 1966 boundary changes).

For calculation of the new county populations for the years 1961 and 1971, OPCS simply used their own records to produce absolute counts for each new district in 1961 and 1971 (published as such in Table 3 of the 1974 volumes and reaggregated to county level in Table 2). For the years including and prior to 1951, a proportionate basis was used for the assignment of population to each new county. However, as the author used old local authority areas to establish the percentage of the population moved, so OPCS used civil parishes and wards. OPCS were able to work at this level of detail since only 47 old local authorities were divided between counties. (The author could have used civil parishes, but the number of divided old areas was considerably higher at district level, which would involve a large amount of work not really justified by inaccuracies introduced into the data at earlier stages.) Furthermore, of all the 47 cases, only

12 had to be calculated on a proportionate basis since although 35 others were split, they were at least divided along civil parish boundaries and at this level a whole amalgamation of areas could be performed.

OPCS then produced a series of county population totals which were compared against the author's data set. Appendix B shows the resultant differences between the two. The most striking is that seen for the year 1939 and is indicative of the weakness of the 1939 National Registration of Population as a source of data. Substantial differences between the two data sets are recorded, the largest being over 152,000 for Greater Manchester. It is for this reason that the 1939 data derived by the author were not subsequently used in the research.

Throughout the remainder of the table the difference between the two data sets can be attributed to three sources, all outlined earlier in the chapter. These are allocation error, inherent error and ratio error.

Allocation error is one introduced through the rounding process and spread throughout the data set (see section 5.1). If a new district is a whole amalgamation of old areas then such an error will not arise. However, if a new district contains part of an old area, the population of the part as at 1971 is expressed as a percentage of the whole area (again as at 1971) and quoted in OPCS (1975b) as a rounded integer percentage. The author used this rounded percentage in her allocation of population to new districts and hence small errors will arise

represented by the differences between the OPCS and the author's data.

Allocation error can be conclusively proved with reference to the 1971 data in appendix B. Inherent error (see section 5.1) does not exist at this time since the old area population figures (from which the reaggregation was done) sum exactly to the old county totals as quoted in the census. Ratio error (see section 5.1) cannot exist as no calculations for boundary changes were carried out on data of this year (the data having been coded directly from the census).

For most counties which are complete amalgamations of old local authority areas (irrespective of their parent county) then allocation error does not exist (see for instance Cambridge, Devon, Kent etc.). Four counties, despite being complete amalgamations at county level, have an error introduced through the splitting of old areas at constituent district level. Summing the percentages quoted in OPCS (1975b), the parts of Northampton RD total 99, and Basford RD (Nottinghamshire), Watford RD (Hertfordshire) and Gloucester RD total 101. This introduces an error (in the author's data) of -238, +708, +545 and +374 respectively.

Some 47 counties contain parts of split old local authorities, and are therefore subject to allocation error. Referring to the 1971 data for the counties of Norfolk and Suffolk, an error of +76 and -76 may be seen. This results from a misallocation of people on the division of the old rural district of Lothingland

between the new districts of Great Yarmouth (Norfolk), and Waveney (Suffolk), which in turn results from the use of the OPCS rounded percentages. Other more obvious allocation errors are between West Sussex and Surrey (43 persons from the division of Dorking and Horley RD), and between Gwynedd and Clwyd (21 persons from the division of Aled and Hiraethog RD). For each county it is possible to calculate the maximum permitted allocation error by taking  $\frac{1}{8}$  of the 1971 population of each split old area within the county and summing them (if more than one). The new county of North Yorkshire contains the most split old areas (eight) and has a 'permitted' allocation error of 1,864. The new county of Tyne and Wear, despite containing only five split old areas has the largest 'permitted' allocation error of all (2,385). If the errors in appendix B are adjusted for OPCS rounding errors (see above, for Gloucestershire etc.), then all the errors are within the maximum permitted allocation error for that county. Most are in fact very much smaller since all but 14 of the 47 counties contain more than one split old area, and rounding of percentages by OPCS can have both a positive and negative effect within a county, one split old area balancing the other.

If this error can be precisely identified in some areas, it should be possible to correct the data set accordingly. For instance, in the above example, it would be possible to add 76 to the population of the new district of Great Yarmouth and subtract the same number from the population of Waveney to balance the

county totals accordingly. However, in other cases, it is more difficult to identify such errors. Some old areas have been split into two or more districts in two new counties. For example, Dorking and Horley RD underwent a three-way division, one part to West Sussex and two parts to Surrey. A known underestimation of the population of Surrey by 43 persons exists, but there is no indication (except by consulting the actual 1974 census volumes) of how these persons should be distributed between the new districts of Mole Valley and Reigate, which both received parts of Dorking and Horley. Other allocation errors are even more complex; the new county of Lancashire, for instance, shared split old areas with Merseyside, Greater Manchester, Cheshire and West Yorkshire. While it would be possible to correct the data set for errors at 1961 and 1971 (from the district data supplied for these two years by OPCS in table 3 of the 1974 census volumes) for years previous to this there is no indication of the extent of allocation error, especially as it is now indiscernible from the other two types of error, inherent and ratio.

The problem of inherent error arises within the data set prior to 1951. This error represents errors introduced through the process of calculation of boundary changes; the precise causes and scale of it are described in section 5.1. The maximum inherent error for the study had been shown to be an excess of some 12,790 persons for the county of West Yorkshire in 1911. This error will still be in the data set somewhere, although it

is difficult to say where as parts of West Yorkshire were moved to South and North Yorkshire as well as Greater Manchester, Lancashire, Cumbria and Humberside on reorganisation. (The population of the new county represents only 55% of that of the old one.) Inherent error does not occur for the years 1951, 1961 and 1971 as the data used for reaggregation are exactly those listed by OPCS in their 1971 census volumes and are not subject to boundary change calculations.

The third type of error discernible in appendix B is that resulting from the use of the percentage multiplier, and is examined in section 5.1. Basically this error stems from the use of a constant percentage multiplier to transfer population as a result of a boundary change and results in a movement of too many people at earlier years, giving an underestimation of the population of the source area and an overestimation of the sink area. At a county level it is generally caused by expansion of a city on the county boundary and is especially severe if a boundary change occurred as a result of this expansion late in the period of study (from 1901 to 1971); by the time such a boundary change has been carried back to the beginning of the study period, the effect of the multiplier is extremely marked. Such an effect may be identified in appendix B with reference to Derbyshire and South Yorkshire. As a result of the Sheffield Order of 1967, an area of Chesterfield RD (Derbyshire) was transferred to Sheffield CB (formerly in West Yorkshire). The 1961 population of this area was 32,224 and represented 32% of

the total population of Chesterfield RD. At all previous censuses, then, 32% of the population was taken from Chesterfield RD and added to that of Sheffield CB even though the development of the area affected by the boundary change (which is known to this author) suggests this to be a false assumption. Previously an area of small mining villages, it rapidly developed as a suburb of Sheffield throughout the 1960s. At early censuses, the population of the area affected by the boundary change was unlikely to represent as much as 32% of the entire rural district, only doing so on 'suburbanisation'. Thus the transfer of 32% of the population was too great, especially earlier in the study period: using this percentage, the author moved some 20,574 and 20,790 persons in 1921 and 1931 respectively; from appendix B it is apparent that the population of Derbyshire is underestimated by the author by some 12,000 persons at each year, and that South Yorkshire (the new parent county of Sheffield) has an excess of some 16,000. It is a reasonable assumption that the 12,000 persons missing from Derbyshire have been moved (in error) to South Yorkshire, and that c.8,000 is more likely to be the population of the area in question at these two dates. The remaining 4,000 difference for South Yorkshire is probably inherent error, together with a possible allocation error of up to approximately 1,000 resulting from the (old) Nottinghamshire contribution to the new county.

Ratio error can also be seen at the scale of whole counties (rather than individual districts as considered above). Appendix

B shows all the new metropolitan counties to have a surplus of people for earlier years, together with a smaller surplus for the new non-metropolitan counties, such as Avon and Cleveland. Surrounding counties show a deficit of people - Lancashire and Cheshire for Greater Manchester, Durham and North Yorkshire for Cleveland, Durham and Northumberland for Tyne and Wear. Urban areas (where population tends to be overestimated) have been grouped together to the urban metropolitan counties, whilst the surrounding old areas, whose population is in general underestimated, now form the more rural / less urbanised surrounding counties.

It is likely that (with the exception of errors for 1939) ratio error is responsible for most of the discrepancies in appendix B. Inherent error is known exactly from the summation of old local authorities to old counties as detailed in section 5.1 - it cannot be more than 12,790. Furthermore, this (largest) inherent error belongs to the old county of West Yorkshire in 1911, which underwent an approximate 35-55-9% split in terms of population on reorganisation. Inherent error should therefore be distributed likewise, reducing its maximum value. Allocation error cannot be more than 2,385; this is for the new county of Tyne and Wear, and represents the sum of 1% of the population of all the split old areas, parts of which are outside the county. Most other counties have considerably smaller allocation errors.

The maximum error for every individual census year between 1901 and 1931 occurs in South Yorkshire. For 1951 and 1961 the

position is held by West Midlands, and for 1971, Gloucestershire. This latter error is due to rounding by OPCS (376 persons), and allocation error (of which the maximum permitted equals 1,102). It is likely that the errors for South Yorkshire are exacerbated by a high inherent error, but they are also due to ratio error resulting from a particularly marked boundary change with Derbyshire. Ratio error is almost certainly the cause of the error for West Midlands in 1951 and 1961 as inherent error is zero (see section 5.1) and the maximum allocation error (at least in 1971) could only have been 1,323.

#### 5.4 PREPARATION OF DATA

In view of the errors shown to exist within the data set at county level (see appendix B), it was decided to control the author's data to that of OPCS, and distribute the errors evenly throughout the districts within each county (an equal percentage to each district). Although the origin of some errors (especially allocation errors) is often fairly clear - and the errors themselves can be assigned to a precise district - this is not always the case, especially in earlier years. Thus, with the exception of the error for 1939, the error for each county was distributed evenly amongst all the districts within that county.

At this stage, then, the author had available to her, for each new local authority area, seven sets of figures representing the

population as at every decennial census from 1901 to 1971. Also available for every new area were a set of population figures derived from the mid-year estimates and spanning the time period from 1971 to 1979. Finally, for the 33 London Boroughs, a set of 1939 data was available based on the mid-year estimates and taken from Morrey (1973).

Although there are methodological differences between these data sets, the author combined them into one for the next stage of the research. The main difference between the census and the mid-year estimates is the date to which they refer. With the exception of 1921, the census has always been held in April (see table 5.3), but the mid-year estimates refer to the population as at 30th June each year. This difference of under three months should not affect the comparability of the data too much. When the 1971 reaggregated census data for new districts were compared against the 1971 mid-year estimates, in 343 of 458 areas the difference between the two was less than +/- 1,000. The maximum gain between the census and the estimate of the same year was one of some 6.5 thousand persons (Plymouth), and the maximum loss, -5.3 thousand persons by South Oxfordshire.

Although the temporal resolution of the data set was now much greater than with the use of the mid-year estimates only, the temporal frequency was not good, the data points being both sparse and irregular - decennial from 1901 to 1931, 1951, 1961 and every year from 1971. It was decided to interpolate a data set using these values, and to produce data at two yearly

intervals from 1901 to 1979. To do this, a small program incorporating a NAG algorithm - E01ADF (NAG, 1981) - for interpolation was written. For each area, all the census figures between 1901 and 1971 were input, together with the mid-year estimates for every alternate year from 1973 onwards. The algorithm interpolated the intervening two yearly values by fitting a cubic spline. Some 40 values for each area were thus produced; to interpolate 29 points from 11 original data values for each of 458 areas took 12.3 seconds of CPU time on the NUMAC IBM 370/168.

Attempts were also made to interpolate a data set by fitting a polynomial (Aitken's method, NAG algorithm E01AAF). Although this is the method of interpolation recommended in the NAG documentation, it gave very poor results, especially in the early (1903 to 1909) and late (1963 to 1969) years. This was probably due to the fact that this method of interpolation performs best with an equal (or similar) number of data points either side of that being interpolated; for early and late years this was obviously not the case.

There was one type of district for which use of the cubic spline gave very unsatisfactory results. At some point in their development, the districts of Harlow, Crawley, Basildon and Stevenage all show a very rapid increase in population over just one decade. In the worst instance (Harlow), this increase was ten-fold over the decade of 1951 to 1961 after its designation as a new town in 1946. Fitting a cubic spline through such data

resulted in a dip in the curve before interpolating through the rapid increase. Figure 5.5 shows the results (in a dashed line) of the first interpolation for Harlow. For this and the other three districts, then, a different method of interpolation was used although the algorithm remained the same. Essentially two interpolations for each district were carried out (three for Crawley which shows two steep increases in population, between 1911 and 1921, and 1951 and 1961). The first of these was to interpolate the population over the period of gradual increase (in the case of Harlow, between 1901 and 1951) and the second for the period of rapid increase, in this case 1951 to 1979. This gives more realistic results than previously for all four places. The results for Harlow are graphed as a solid line on figure 5.5.

For the 33 London boroughs, a set of 1939 population figures was also available derived from the mid-year estimates. Thus the interpolation for these areas was repeated incorporating these data. Comparison of the results gave some idea of the success of the interpolation algorithm. Population change is a complex interaction of births, deaths and migration, and it is doubtful that a method of numerical approximation as crude as this would be effective. The results of this comparison, then, were perhaps a little surprising. Some 17 of the 33 London boroughs showed a difference of less than +/- 10,000 between the interpreted value and the actual value. This may seem to be quite large, but the population of the smallest London borough in 1931 was estimated at over 71 thousand, with 20 over 200 thousand (excepting the

Figure 5.5: Interpolated population for Harlow.

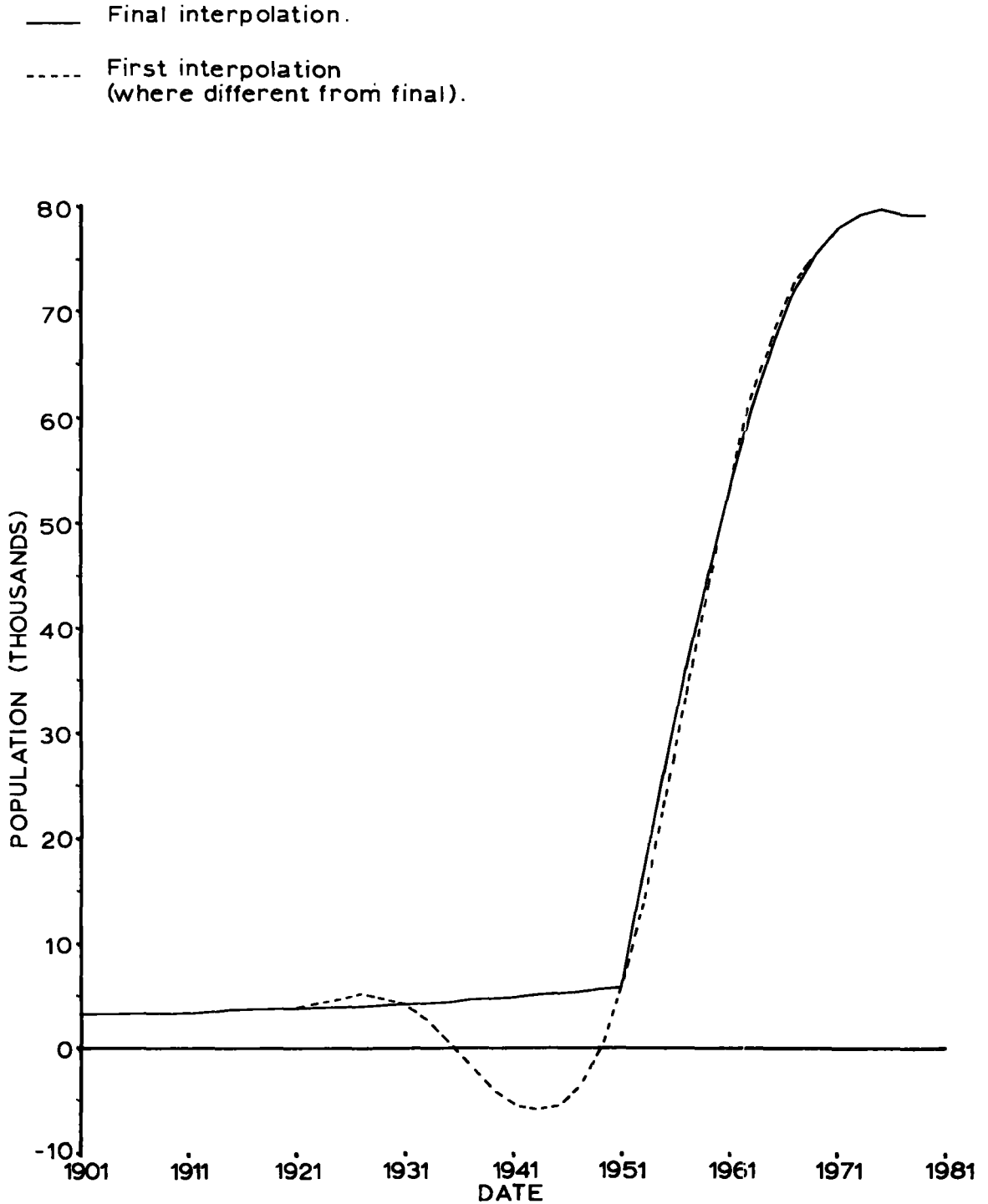

City of London). The difference for eight of the 17 was in fact less than two thousand. A further eight had differences between 10 and 20 thousand and for a last group of eight, the difference exceeded 20 thousand, the largest being 38.8 thousand. This last group of eight is characterised by enormous increases or decreases in population over the years 1931 to 1951. Seven are the peripheral London boroughs of Bexley, Bromley, Enfield, Harrow, Havering, Hillingdon and Sutton, all of which doubled, or almost doubled, their population over 20 years (the extreme case being Harrow which grew from 96.7 thousand to 219.5 thousand). The eighth is the inner London borough of Tower Hamlets, declining in population from 488.6 thousand in 1931 to 230.8 thousand in 1951.

The author then was satisfied that, given the enormous changes in these populations and the inevitable degree of uncertainty associated with Morrey's (1973) figures, the use of the interpolation algorithm gave reasonable results which were representative of the true situation. For the two decades 1931 to 1951 (when nine values had to be interpolated between two end points) no other part of the country experienced growth (or decline) rates quite as large as for these eight London boroughs. Thus the interpolated values may be more accurate. At other dates, the algorithm was only required to interpolate four values between end points (the third, fifth, seventh and ninth years of the decade), thus there is less chance of a wide margin of error. Known problems exist for districts with very steep increases in

their growth curves - namely New Towns - but a satisfactory solution seems to have been achieved here by interpolating the two parts of the curve separately.

There remains only one known but unsolved problem of using an interpolation algorithm. This problem arises when a district has an artificially high number of enumerated residents on census night, a condition which occurred in some holiday resorts in 1921 (see table 5.4), and, secondly, for the district of Nairn in 1971. The latter district has had a resident population of about 8,000 for most of this century. However, on census night of 1971, some 3,000 extra persons were enumerated in the district as a result of the Ark Royal moored offshore (see section 5.2). Thus the population was held to be an artificially high figure of over 11,000. Such a figure, when used in the interpolation procedure, has increased (by increasing amounts through time) the population of the district from 1961 to 1971, giving a false impression of constant population growth. In this case as no interpolation was necessary after 1971 (due to the use of the mid-year estimates) the effect was only seen through one decade. However, if other cases of one-off artificially inflated populations do exist (such as in 1921) then the data of both the preceding and succeeding decades is likely to be inaccurate. The full extent of this problem is unknown, but it seems likely that the case of Nairn (with a large increase on a small initial population) represents the extreme.

In conclusion, then, a data set had been assembled. Whilst the attributes of this data set are constant (see figure 3.1, page 39), the method of collection by no means meets the criteria as laid out in the framework. The contents of the data set can never be proved definitely either right or wrong; although not good enough for detailed local studies (for which some other means of enumerating population change would be used anyway), it seems certain to be good enough for use in animated filming and other tasks when considering the national territory or regional subdivisions. For mapping to be possible, a topographic data set is also required, representing the outlines of the areas on which to map these data. The next section describes the set used in this work.

## 5.5 TOPOGRAPHIC DATA

The areal extent of the post-1974/5 local government boundaries is widely available from OS maps; however, for computer-aided mapping involving area-infilling, a set in digital form was essential. A set of district, county and economic planning region boundaries has been digitised and distributed by Baxter (1976) through the Building Research Establishment (BRE); these outlines were utilised for mapping the population data. A more detailed set subsequently became available for purchase from the DoE (Rose, 1981, pers.comm.) but the Baxter set is entirely

adequate for the mapping carried out.

The boundary data were originally digitised from two source maps at a scale of 1:625,000. The resolution of the data set is fairly low: whilst suitable for mapping at small scales used here, they cannot be successfully used at larger scales without the gross generalisation of boundaries becoming apparent. The data were available on magnetic tape in two formats; the first described the regions, counties and district as complete polygons (three files), and, secondly, as a set of boundary sections which could be built up to any level of the hierarchy of local government areas, or any ad hoc combination of districts (one file). The first format is the simplest method of describing a polygon (Baxter, 1976); the boundary of each area is described as a string of straight line segments. Throughout all the files (including the boundary section file), the co-ordinate system used for point referencing is based in the National Grid; the resolution is 100 metres. Closure of each polygon is assured in that the first point is always the same as the last. In all three files, each polygon is digitised in an anti-clockwise direction; this, combined with a simple key, enables polygons with islands and lakes to be identified. A severe problem associated with the use of polygons described in this format is that each boundary (excepting coastal ones) is stored and hence drawn twice. This "double" drawing of boundaries is frequently a problem on mechanical output devices with low repeatability (see section 7.3). Polygons digitised in this format are useful for

mapping if the user does not have access to, or does not wish to use, a program to build polygons from individual boundary sections. However, this was not the situation in this case; the program GIMMS (see section 7.1.2) contains an algorithm for building polygons and so these three data files were not subsequently used for mapping. However, certain descriptive statistics were determined from them since they define the polygons ultimately handled by the area shading section of GIMMS. These are set out in table 5.6.

The remaining file on the magnetic tape consisted of a series of boundary sections, each with two identifiers. A boundary section comprises a string of segments between two adjacent polygons. For these purposes, the external area (the sea) is also considered to be a polygon. Preceding the co-ordinates (which constitute the segments of each section) are two 'feature codes', one representing the left-hand, and the other the right-hand identifier (in the direction of digitising) for the adjacent polygons. Providing the end-points of the sections represent the node of coincident sections on the ground, and so long as the naming of either the right- or the left-hand area code first is consistent, then the boundary sections can be reversed (if necessary) and chained together to build up polygons for subsequent mapping. Although only one file of segments was provided, it was possible to select which level of local government areas were used to map data through a hierarchical labelling system for the area codes. Except for the external

Table 5.6: Descriptive statistics, polygons.

	<u>Districts</u>	<u>Counties</u>	<u>Regions</u>
No. of areas	458	64	10
Min. no. of points/polygon	5	21	113
in area	Hastings	Isle of Wight	East Anglia
Max. no. of points/polygon	321	537	1507
in area	Argyll and Bute	Highland	Scotland
Mean area (sq.km).	48.48	3421.87	20889.07
Min. area (sq.km).	5.44	340.92	7279.52
in area	City of London	Isle of Wight	North West
Max. area (sq.km).	5395.02	22985.56	60685.38
in area	Perth and Kinross	Highland	Scotland

Source: Calculated from the Baxter (1976) polygon data.

area (the sea) which was given a code of 0, each district was allocated a unique six digit code by Baxter (1976). The first two digits represented the 'grandparent' region code, the second two were those of the 'parent' county code, and the last two specific to the district within each county. Thus, by selecting the number of digits read, and discarding any segments whose area codes at that level were identical, boundary sections could be retrieved from this file at both a county and region level.

Table 5.7 illustrates some of the characteristics of the set of boundary sections which was subsequently input to GIMMS for mapping.

To summarize to this point, then, both the thematic and topographic data were ready to be input to an animated film showing population change in Great Britain from 1901 to 1979. The following chapters describe the creation of such a film, beginning with design strategies (chapter 6).

**Table 5.7: Descriptive statistics, segments and boundary sections.**

---

**For the whole file:**

No. of coordinate pairs	9,083
No. of segments	7,768
Total distance of boundaries	29173.6 km.
No. of boundaries	1,315
Min. segment length	0.1 km.
Max. segment length	21.5 km.
Mean segment length	3.8 km.

**For the boundary sections:**

per boundary.

Max. no. of coordinates	150
Min. no. of coordinates	2
Mean boundary distance	22.2 km.
Min. boundary distance	0.3 km.
Max. boundary distance	641.9 km.

**Source: Calculated from the Baxter (1976) segment data.**

## 6 MAP DESIGN STRATEGIES

The previous chapter examined the derivation of a matrix of some 40 historical population totals for each of 458 districts between the years 1901 and 1979. Using these as the input, this chapter examines the design strategies for the generation of a computer animated film showing population change in Britain, 1901 to 1979.

Given any thematic data set and an appropriate set of location co-ordinates to which the data set refers, the construction of a map from such data which is accurate and conveys a true picture of the distribution to the reader requires a hierarchical set of decisions to be taken in a specified order (Jenks, 1963). These may be termed primary, secondary and tertiary decisions. In this instance, there is only one primary decision to be made: given a data set and location co-ordinates, in what form are the two to be portrayed? Figure 2.1 (page 18) shows some of the many types of map symbolism which may be used, and it is the responsibility of the map producer to select the most appropriate of these. In this research, the decision is whether to illustrate population change using a two- or three- dimensional map: factors generally taken into account are the precise form of the original data (point, line or area) and the intended use of the finished product. In this case, the latter characteristic is of particular importance in that the maps are destined for use in animated filming: each map must be considered not only on its

own, but also in sequence within a time series as well. This places special constraints on map design (see section 6.3).

A secondary decision may be stated simply as how best to portray the data using the selected map type. This usually involves some classification or generalization of the data - in this case, how is population change to be measured and portrayed? There are many possible solutions to the problem, ranging from a simple (but often misleading) change in absolute numbers, to complex indices of change devised for use in the study of population dynamics, such as the index of concentration and of net redistribution (Duncan et al, 1961). The application of some of these measures in relation to this research is considered in section 6.2.

Remaining decisions concern the final appearance of the output map; these may be termed tertiary decisions and vary widely, depending on the type of map symbolism being used. In two-dimensional mapping, they concern layout, colour, text etc., whilst in three-dimensional mapping the concepts of altitude, azimuth, block size etc. are involved. Such decisions taken in relation to this project are examined in section 6.3.

## 6.1 WHAT TYPE OF MAP?

The actual distribution of the population represents a statistical surface, albeit abstract and not easily conceived.

Strictly, it is a two-dimensional surface: unlike the topographic surface, it has no vertical dimension, as each human individual can be located by two co-ordinates only. However, every map involves an element of scale, and is a reduction of reality; hence individuals are grouped and it is convenient to record their number with reference to one place. This number can then be regarded as the vertical (Z) dimension (c.f. a spot height), and the distribution of the population regarded as a statistical surface just as is the topography.

Perhaps the easiest way to visualize such a surface is to construct a block diagram or three-dimensional map. Comparison of successive blocks mapped in a computer-animated film in theory reveals population change. However, this method of animated filming is scarcely novel: as described in section 2.3, Tobler (1970) constructed one of the very first computer-animated films in this manner depicting population change in the Detroit region. Thus, whilst the construction of a series of block diagrams is a feasible way of portraying population change, it depends on the simulation of volume. Whilst Rowles (1978) has shown that the 'average' map reader can interpret block diagrams to a fairly high degree of accuracy, it is not known whether this holds for animated three-dimensional maps. It was decided, therefore, to use two-dimensional mapping, and hence to depict population change without the use of volume. Such displays are both common and widely accepted in static, single map form.

On a dimensionally-based classification, there are three forms of two-dimensional map symbolism (see figure 2.1, page 18): point, line and area. The type selected depends on the form and characteristics of the data displayed. Consider first line symbolism: for some characteristics of the population, chiefly migration, the flow vector type of map is unsurpassed (see for instance Tobler, 1981). However, the data set described in chapters 4 and 5 is essentially stock rather than flow data (see section 3.3.1), and contains no elements of directional change - which are essential to this type of mapping: only non-directional implied change calculated by comparing population totals at two separate times is available. Hence flow mapping could not be used.

Although the data set is based on areas (British local authority districts), areal data can be approximated to a point, enabling the use of isopleth mapping (see for instance Rosing and Wood, 1971). Lines representing equal characteristics of the population (density, potential, etc.) may be calculated and mapped. However, there are a number of reasons why this method cannot successfully be used in population mapping in general and animated filming in particular. The assignment of areal population data to one particular point within that area is subjective in that the point may be in an infinite number of places within the area - including the centre of gravity of population and the mean of the X and Y boundary co-ordinates - yet at no one of them does it truly represent the actual

distribution of the population. The problem is essentially a two-dimensional version of trying to represent a set of numbers by some measure of central tendency. One commonly used approximation to this is the weighted centre of population, as described by Craig (1977) and calculated by him for many of the different local government areas in Britain. Indeed, the National Grid references for wards in the 1981 SAS are calculated from Enumeration District centroids using this procedure. However, even when the data have been assigned to a point, the interpolation of contours between such points is a field of research within itself: there may be several possible results, all in theory correct (Grassie, forthcoming). The use of isopleth mapping in computer-animated filming is possible, especially if the distribution of the phenomenon under study is rapidly changing (e.g., weather pressure patterns). However, changes in population (or any derived measure) are small in relation to the range of such populations; thus changes in contours designed to cover the entire range of values would be slight, and large amounts of local detail lost. (This is of course a problem of scaling, and common to many types of population mapping.)

Many of the same arguments apply to the use of point symbol mapping: again, the determination of any one 'point' for representation of data collected over an area is suspect and may mislead. Moreover, problems of the amount of change in relation to the range of the data limit the use of this method in

computer-animated filming. A further problem of point symbol mapping occurs in overlap of the symbols: unless these are few in number and / or small in size, there is a danger of losing detail. Figure 6.1 is an example of the use of the proportional symbol in time series: although the data has been aggregated to county level and symbols drawn quite small, overlap still occurs and is at the expense of detail. The coarse geographical level ensures that the inhomogeneity of population distribution within counties is lost, as is the difference between county populations, since many symbols are of a similar size. Symbol size could be increased, or the map drawn at district level, but in each case overlap of symbols would cause considerable perceptual and computational problems. Rase (1980) has published such a symbol map, based on the kreise of Germany: much of the detail is extremely difficult to extricate and the synoptic impression of the map is of considerable clutter. Figure 6.1 is drawn using a modified version of his software.

The remaining type of point symbolism which might be used is the dot. As early as 1900, Hettner had argued that the simplest picture of the population of an area is provided by this method - each individual or an equal number of individuals is represented by a uniform sized dot, 'correctly' located on the map (Kosinski, 1979). The number of individuals represented by one dot must be small in relation to the range of the data; the larger the group, the more the location of the symbol is problematic - it becomes a normal (but solid) point symbol. This method should be suited to

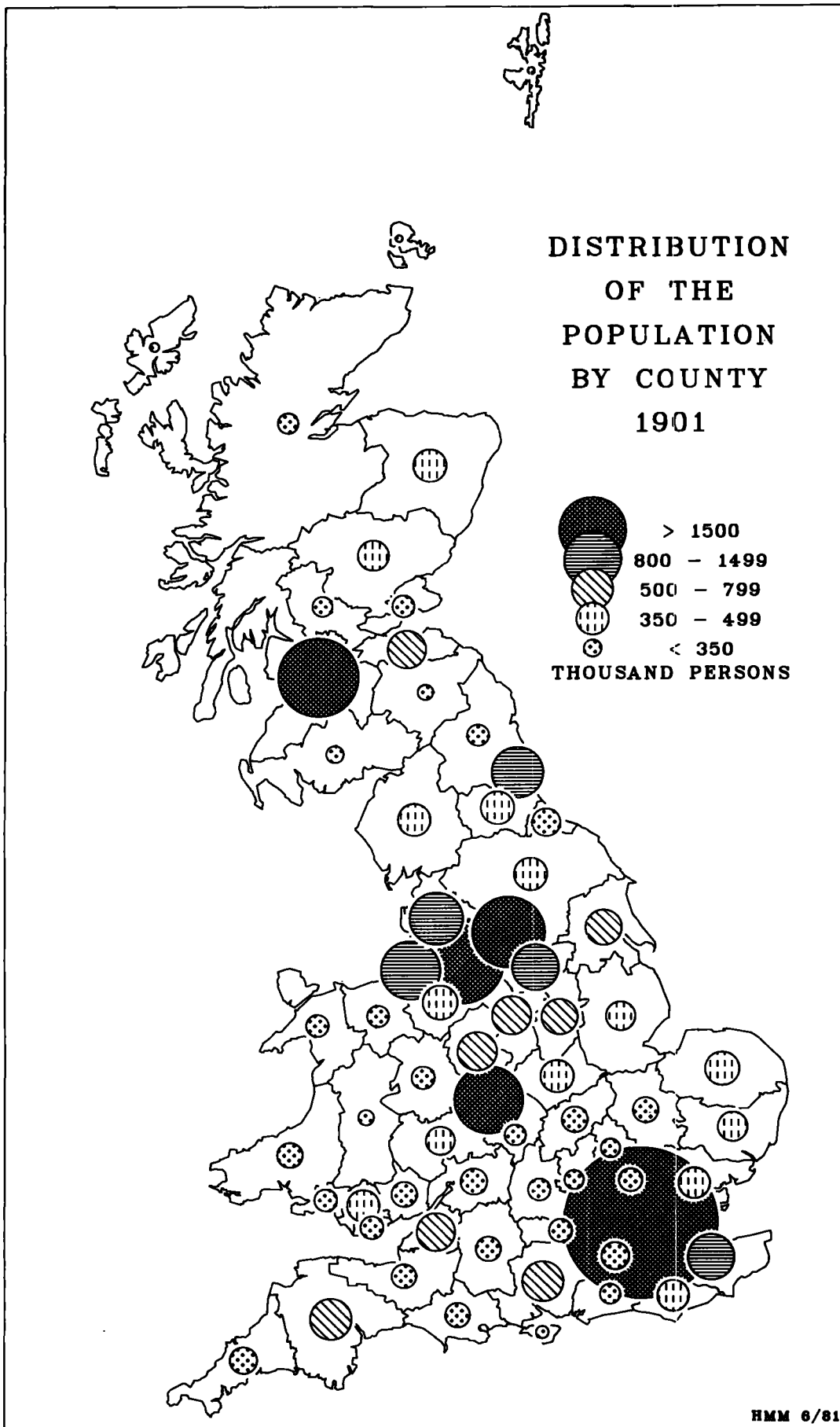

Figure 6.1.1

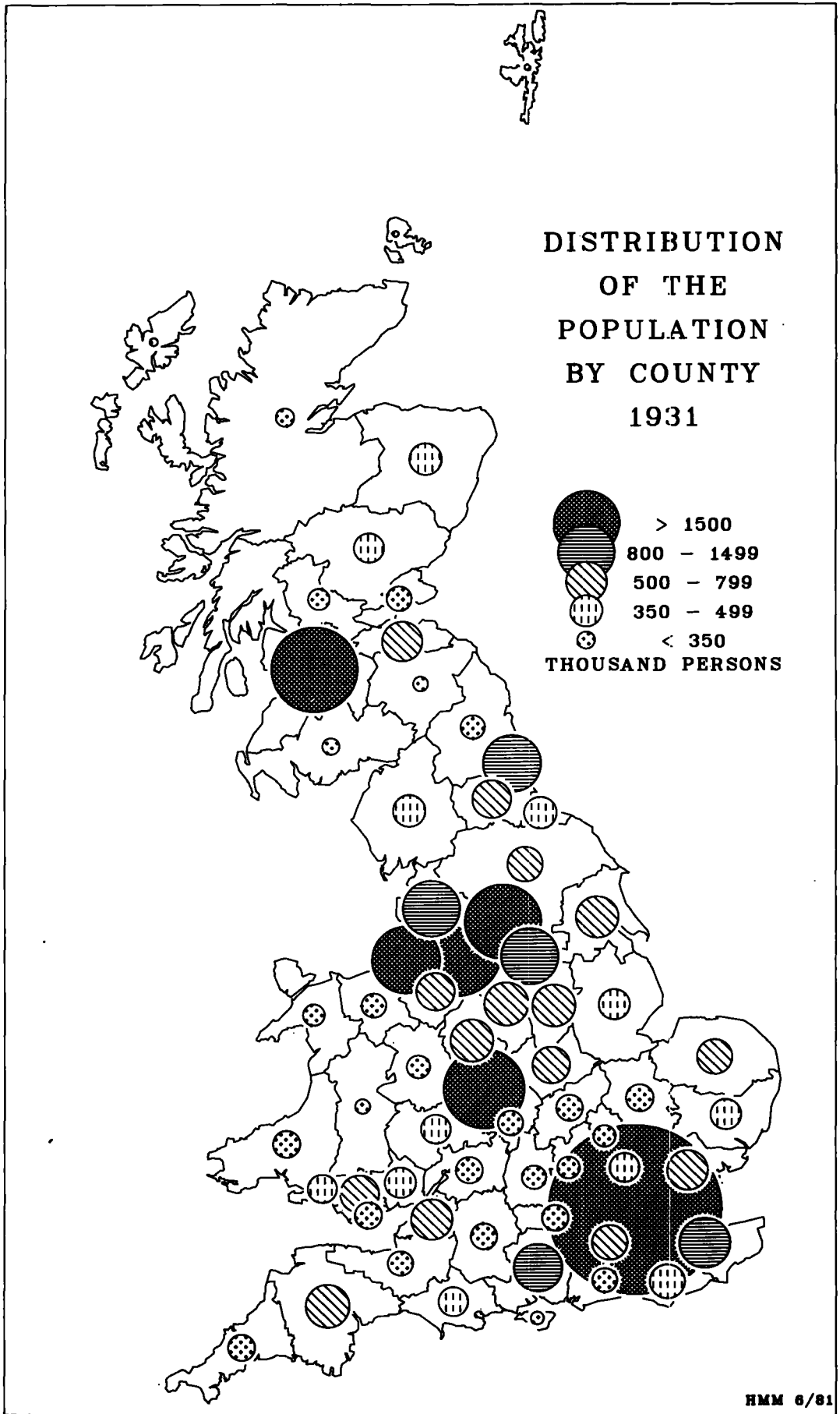

Figure 6.1.2

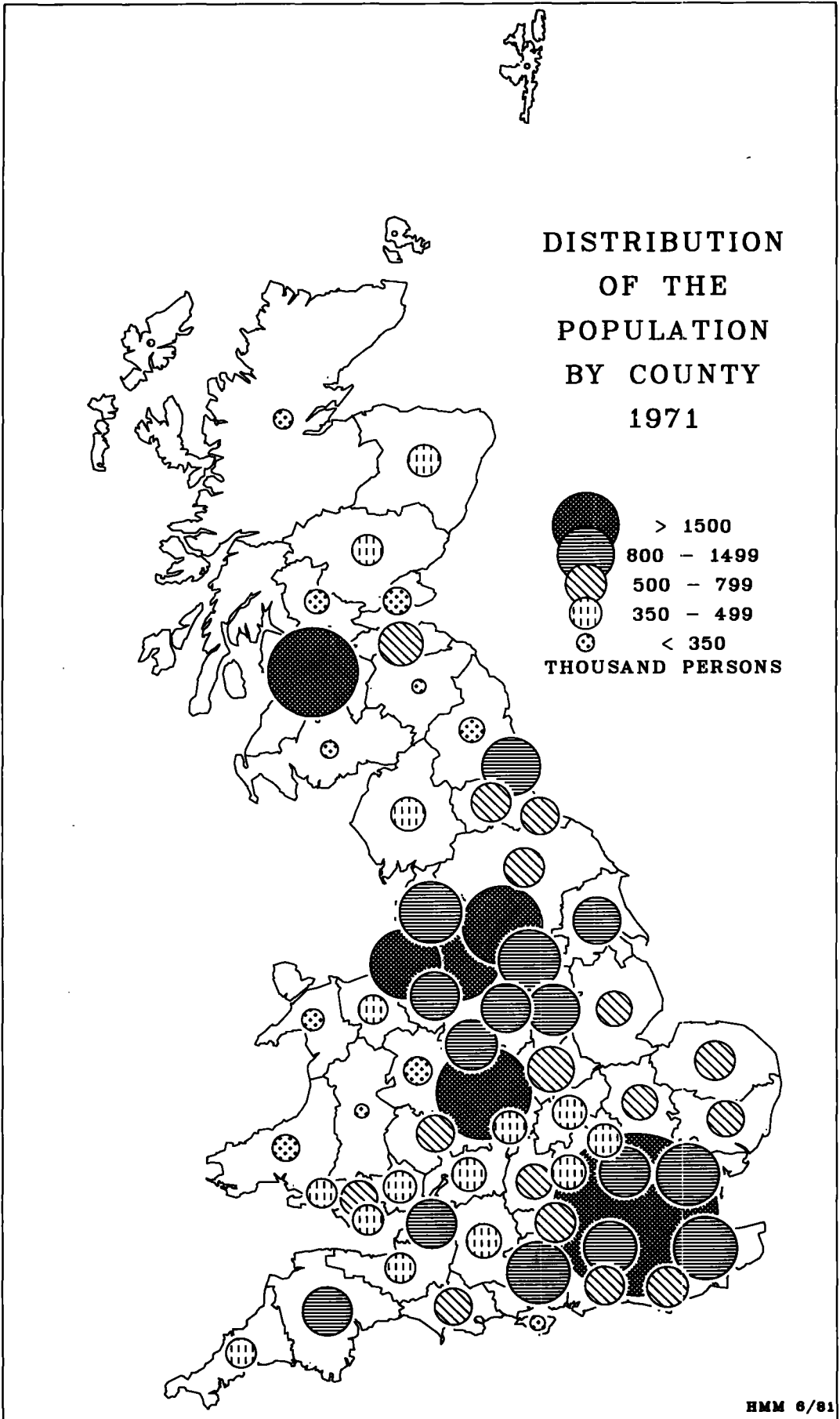

Figure 6.1.3

the mapping of most population data since it is simply a case of distributing the dots over the area to which the data refer. Furthermore, Robinson et al (1978) have argued that this method gives a good visual impression of relative density. Olsen (1975) and Provin (1977), however, have shown user perception of such displays only to be on an ordinal scale (London has very high densities whereas those in Norfolk are lower, for instance); it seems that the map reader, especially one who is untrained, has difficulty in estimating densities on an absolute scale from a single map. The estimation of such values from an animated film is more difficult still, not least for other reasons covered in section 6.2.

In principle, a film could be constructed simply by increasing or decreasing the number of dots per area in relation to any increase or decrease in population. However, whilst this may be true if the area under consideration is divided into small units approximately equal in size, it is not the case with a map of the population of Britain at the small scale necessitated by animated filming. The largest number of dots invariably occur in the smallest areas (notably the London boroughs) where they coagulate to form a solid block. Moreover, although no research is known to have been carried out, the author suspects the film viewer would encounter problems with the perception of such a series of maps: the estimation of changing ordinal densities is probably just as difficult as is the estimation of static absolute densities. Even though the motion of the animated film is

supposed to remove the need for visual interpolation between maps, the limitations of this type of symbolism are clear. Finally, although reasonably easy to construct by hand, dot maps are difficult to automate. Dot placement depends on the use of geographically constrained random number generation and, with simple routines, actual placement of the dots can be too regular and even. The amount of computer time needed for the construction of such maps is large: the placement of every dot has to be calculated, and co-ordinates for every dot stored for later plotting (c.f. line shading where only the beginning and end points of every scan line need to be calculated and stored). There is also a mechanical problem of plotting the maps on mechanical vector-type plotters: it is wise to sort the dots into geographical patches to minimise pen-travel time. Furthermore, if using a pen plotter, the supply of ink to the pen is likely to be irregular when many pen-up / pen-down moves are made (Waugh, 1979). Figure 6.2 provides an illustration of the use of dot mapping on time series data. Dots were allocated at the district level: over much of Great Britain the effect of scale is apparent (it is not possible to locate a few dots in a large area with any degree of accuracy). Population change can only be implied by change in the number of dots, not their location (which is dependent on random number generation). The maps are not good indicators of population change, and each took between 19 and 24 seconds of CPU time at NUMAC to produce; thus to draw in large numbers for an animated film, is ~~is~~ unreasonably expensive.

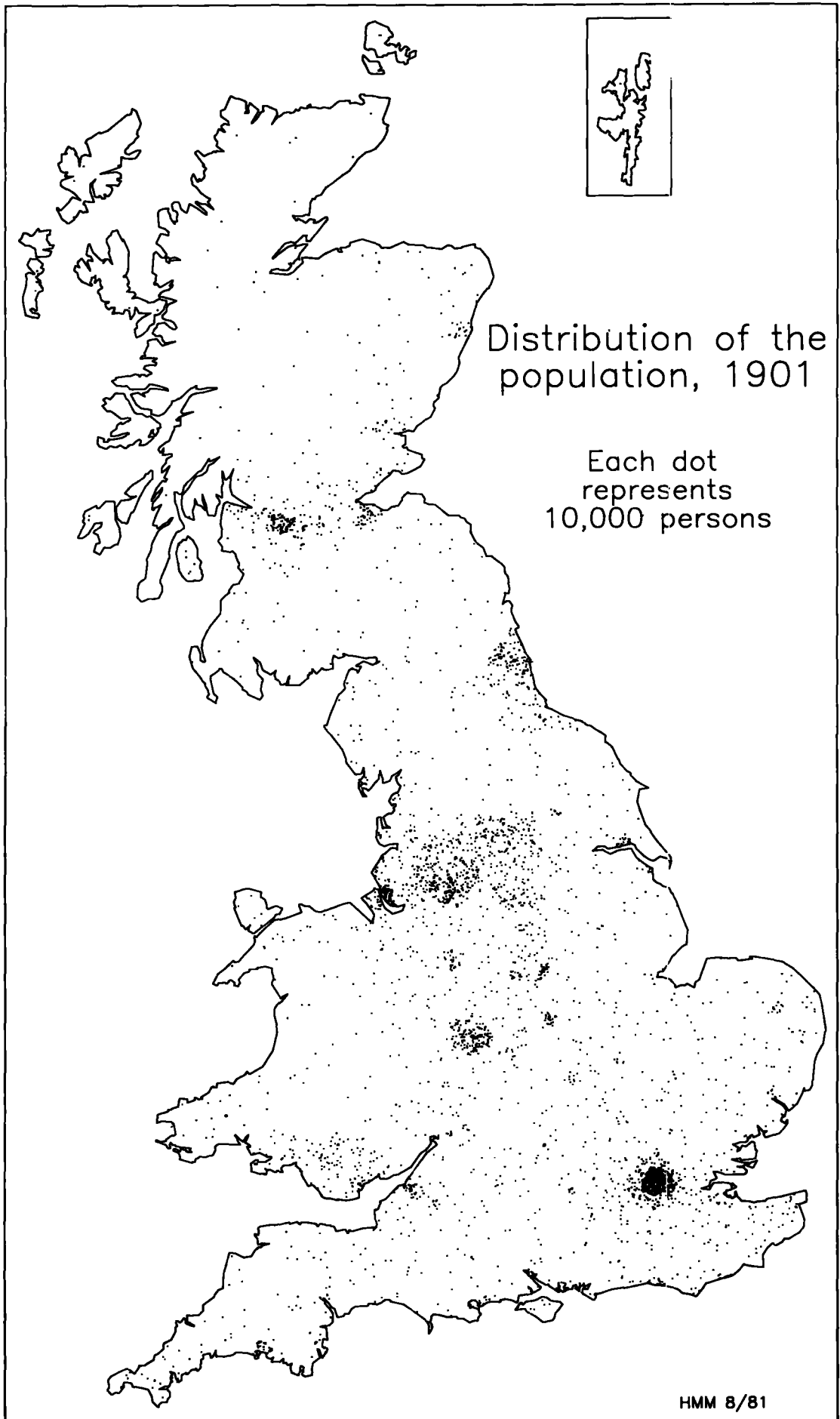

Figure 5.2.1

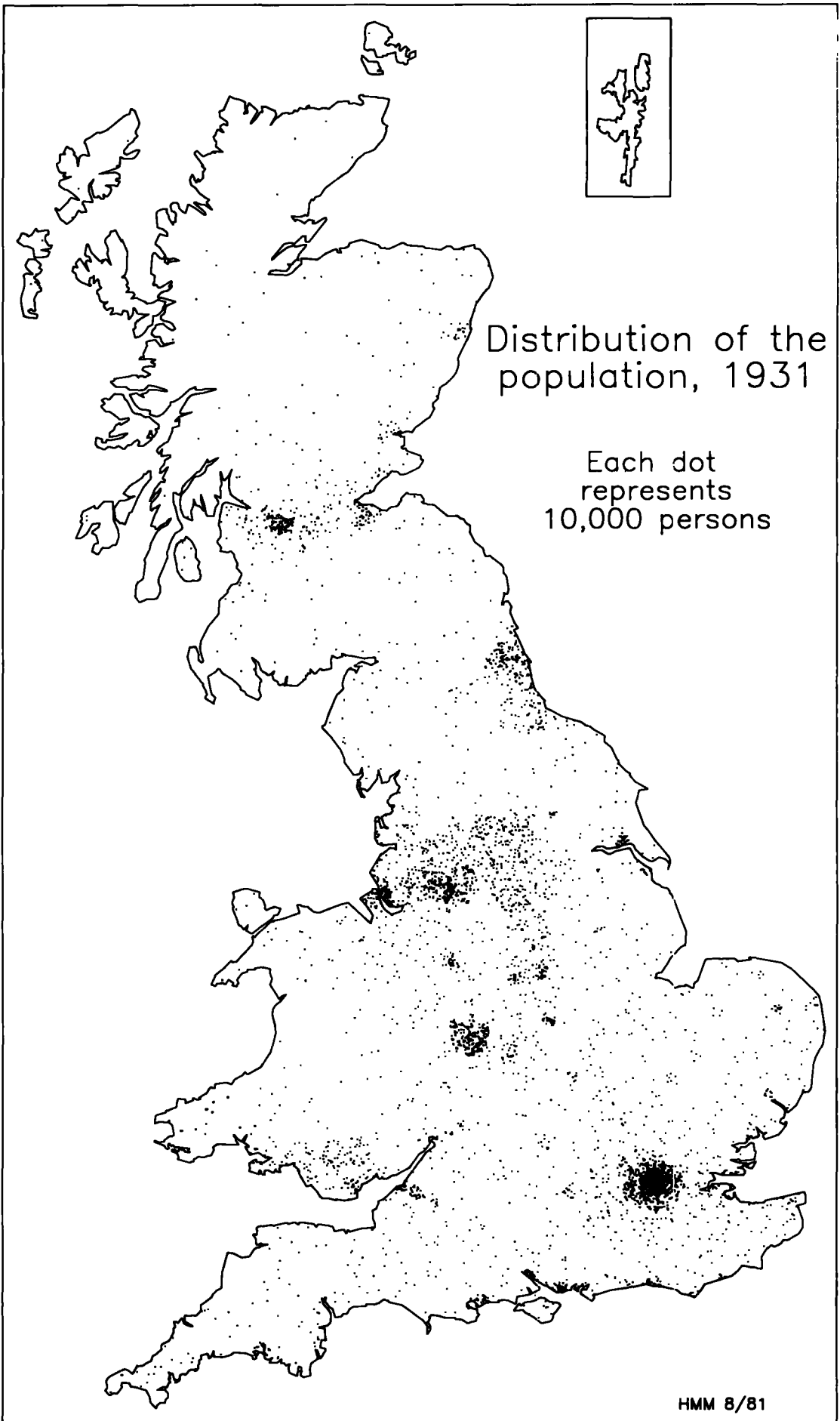

Figure C.2.2

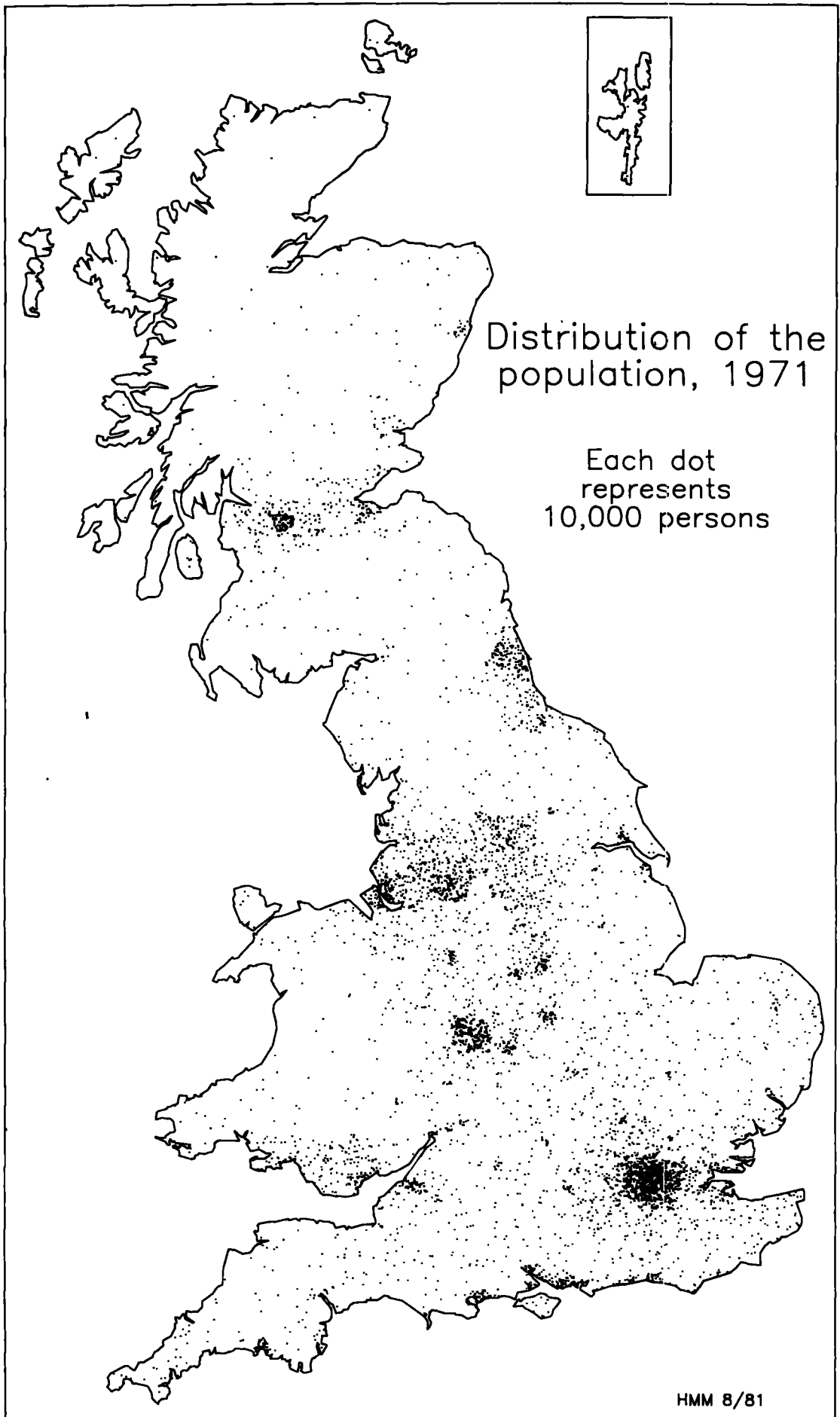

Figure 6.2.3

(To aid comparison, a choropleth map of the same data drawn by GIMMS would take between 10 and 15 seconds, dependent on shading patterns.)

If all types of point and line symbolism and 3-D (simulated volume) mapping are discounted, area shading alone remains. The notion of the distribution of the population as a statistical surface has been outlined (above), analogous to the topographic surface. The analogy however is not complete for, whereas the topography forms a continuous surface with no breaks, that of the population contains breaks, gaps or voids, thus rendering it non-continuous. The nature of these voids depends on scale. At the largest scale, they are represented, for example, by industrial sites in urban areas. At a national scale, remote rural areas may be viewed as voids where there is no population - see, for example, maps in CRU/OPCS/GRO(S) (1980). Internationally, mountain ranges and deserts form such voids. Thus, rather than consider the distribution of the population as a differentiable continuous surface (which is what isopleth mapping and, to a lesser extent, point symbolism and dot mapping do), it is a convenient and simplistic, but realistic, portrayal of the data to view it as a series of plateaux, with breaks representing discontinuities in the statistical surface engendered by the edges of the data collection area. The use of areal symbolism then allows entire areas for which no information on internal inhomogeneity is available to be shaded in one pattern, distinguishing them from areas with different overall

characteristics.

How such areas are defined represents the difference between choropleth and dasymetric mapping (the two types of areal symbolism, see figure 2.1, page 18). In dasymetric mapping, the map producer defines areas of equal characteristics (for instance population density), and shades them accordingly. It is important to note that the determination of areas is in the hands of the map producer, who will group the data points to areas bounded by breaks in the statistical surface; there is no need for the sequence high to middle to low in going from area A to area B to area C (as in isopleth mapping). Choropleth mapping, however, is used for data in which the boundaries of the shading zones are not calculated or selected by the map producer, but represent some previously defined areal unit (generally a political or statistical division of the area being mapped). Such boundaries do not necessarily coincide with breaks in any 'true' statistical surface although they may do so: for instance, the pre-1974 system of local government areas in Britain allowed for areas to be wholly urban or rural in nature - thus if mapping population by these units, the boundaries could well have coincided with a change from a rural to an urban environment. That overspill from urban to rural areas occurred and rendered the distinction inaccurate at least was one reason for the local government reorganisation in 1974 (see chapter 4). But the new districts are now a mixture of both the urban and rural environments, and the boundaries marking a break that would be

shown on a map rarely coincide with marked discontinuities existing in reality. This can be demonstrated by comparison of maps based upon districts with those based on smaller areas - for instance the maps of figure 3.3 (page 67-69) with the 1 km grid square maps in CRU/OPCS/GRO(S) (1980).

Whilst all types of areal symbolism could be used in animated filming, it is clear some are more suited than others for use with the data set. The dasymmetric map could be used - it is easy to envisage (for instance) a series of maps, each showing changing areas of equal population density at one point in time. However, the construction of this type of map is difficult. Some form of external information is required to determine the edges of such groups (breaks in the statistical surface). For this reason, the process is difficult to automate (Robinson et al, 1978). The quality of the data set is not high enough to begin grouping areas and, since such an exercise would have to be undertaken manually - at least for a substantial part - the results from such a data set would not justify the work required to map the period 1901 - 1979. Moreover, the combination of changing value and changing shape of area between frames was considered at an early stage to be liable to be extremely confusing. However, in animated filming of other data types (such as from satellite imagery), dasymmetric mapping should not be ruled out entirely, as the determination of such areas is clearly possible (see section 3.2).

By a process of elimination, then, choropleth mapping is the one technique still remaining by which it was thought animated filming of population change using the available data set - and indeed many others - could be carried out, and be meaningful to map readers versed in the use of traditional, static maps. Such a selection of the remainder accords with the comment of Robinson et al (1978) who concluded that

'it is employed when the problems of doing any other sort of mapping make it out of the question'.

The next section examines this technique and its limitations.

#### 6.1.1 Choropleth mapping

The term choropleth derives from the Greek choros, meaning place or area, and plethos, meaning number or magnitude - the mapping of the number of individuals or occurrences within a fixed areal unit. The principal advantage of the choropleth technique is one of ease of compilation and use. The cartographer can simply shade a pre-determined area according to the value of the phenomenon being displayed. If the boundaries of such areas are in digital form, then choropleth mapping is a relatively easy process to automate, as evidenced by the early development of what is probably still the most widely used computer mapping package, SYMAP, developed in 1963 (Schmidt and Zafft, 1975). Choropleth mapping, especially if automated, is

simple and quick; it can serve an important role in the critical analysis of statistical distributions, and can be developed to high levels of sophistication if care is taken in map design.

Because it is easy to use, choropleth mapping has achieved widespread popularity - so much so that choropleth maps

are sometimes regarded as being the last word in cartographic accuracy and scientific indisputability'.(1)

This is unfortunate since choropleth mapping has many inherent limitations. As with any form of mapping (and perhaps more so than with most), the map can only ever be a sampled and scaled version of reality. More specifically, problems arise through the use of areas; principally, it is not possible to use absolute numbers. If this is done, then any resultant patterns in the map are liable to be partly (and often substantially) a function of the size of the data collection unit. (The exception to this rule is if the areas used are exactly equal in size e.g. grid square mapping.) This should be an obvious limitation of choropleth mapping, but Williams (1976) illustrates violations of this rule with examples from no less than the Annals of the Association of American Geographers and from the New York Times. Totals have to be related to the area of the data collection unit, giving rise to the concept of density (occurrences / unit area). The use of population density in this research is considered further in section 6.2.1.

---

1 Liebenburg, 1976.

Liebenburg (1976) has listed a number of factors which affect the accuracy, reliability and legibility of SYMAP-produced maps. Some of these factors apply more to isopleth than choropleth maps (SYMAP itself produces both types), but they can be applied to choropleth maps in general and to this research in particular. They are listed as follows:

1. Scale and projection of the base map.
2. Nature of the statistical data and the statistical surface concept employed.
3. Reliability of the data.
4. Position of the data points.
5. Shape and size of the unit areas.
6. Number and scatter of the data points.
7. Choice of class interval.
8. Symbolisation.

The scale and projection of the base map are important in choropleth mapping since the latter depends on areas, which in

turn are heavily influenced by these two factors, especially by projection. All maps which hold distance and bearing true necessarily distort area. When mapping at a world scale, this distortion can be marked, and since the distribution of a variable is presented by area, the untrained map reader may be misled (see Williams, 1976). Over smaller areas, such distortion becomes correspondingly less serious for most purposes, and, whilst it occurs in the maps presented here, it is not considered to be severe enough to warrant further examination. Distortions in mapping based on the National Grid projection (a modified form of the Universal Transverse Mercator projection) are briefly described in Harley (1974).

The second factor, the division of the statistical surface to pre-defined areas has been discussed in section 6.1, whilst the third factor is examined in chapter 5. Factors 4 and 6, relating to the data points, are conditioned in choropleth mapping by the number of areas to be displayed - these factors play a greater role in the fidelity of isopleth maps. It is factor 5 which most affects the legibility of a choropleth map - and this in turn determines the accuracy of the picture of the distribution obtained by the map reader. In a choropleth map of areas which are uneven in size, it is not those areas which exhibit extremes in data values which are visually dominant, but those which are largest in area (see Dudley et al, 1981). Conversely, the distribution of a phenomenon through smaller areas is harder to read. There is no real solution to this problem, which

unfortunately occurs in this research as a result of the marked range in size of British local authority districts (274 ha to 675,628 ha).

Factor 7, the choice of class interval with which to divide a range of data, can markedly affect the effectiveness of the resultant map. Such a choice forms an important secondary decision in the design of a map (see Evans, 1977), and is therefore considered in section 6.2. Similarly the choice of symbolism (factor 8) by which to depict a distribution can affect the legibility of the final map; this is considered in section 6.3.

In summary, then, there are marked limitations in choropleth mapping, especially in its dependency on area: the inability to display absolute numbers and the effect of the size and shape of the areas forming particular problems in this research. However, it is the only technique which could effectively be used given the format of the data (based on local authority areas) and the shortcomings of other available methods (see above).

Having selected choropleth mapping, the important secondary decisions of how exactly to measure and portray population change are now examined.

## 6.2 MEASURES OF POPULATION CHANGE

If choropleth mapping is to be used, how then is population change to be determined for presentation by this method? Using the animated film, there are two ways of suggesting this to the viewer. The first of these is to juxtapose a series of maps of the distribution or density of the population at successive points in time on film, enabling the viewer to make comparisons and gain an idea of the change taking place. No actual measure of change is shown: the method depends on the motion of the film to assist the reader in determining where (and when) change has occurred. Each individual frame in the film is simply a 'time slice' and, by itself, presents only the distribution of the population at one point in time. Hence this presents implied change.

The second method which may be used in animated filming is the presentation of measured change. Here some actual measure of change in the population is calculated and mapped. Such a measure often used is a simple percentage change in the population between dates one and two. The resultant percentages are displayed on a map, and successive frames may be combined to form an animated film. The important difference between this method and the use of implied change is that each map in itself provides an indication of change in the population over a specified time period, but no information on the basic characteristics at any one time. The use of measured change in

animated filming may be criticised in that, in effect, it presents change twice: once in each map, and once via the motion of the film. However, whilst this is true, it does not necessarily invalidate the use of measured change in animated mapping: it should be possible, for instance, to separate areas of persistent decline in population (where a loss is shown on several successive frames) from areas which fluctuate in population where, although over any one short period population loss could be as great as that in areas of persistent decline, this may not continue over an extended time period and thus would appear on fewer successive frames in the film.

The following section examines measures which may be used to represent implied change: measured change is examined in section 6.2.2.

#### 6.2.1 The representation of implied change

The representation of implied change uses as a starting point a series of 'time slice' maps at successive dates. Since a limitation of choropleth mapping is that absolute numbers cannot normally be used, some account has to be taken of the variability in size of areal units. This leads to the use of the index of population density. Clarke (1972) notes

'the concept of population density, relating numbers of people to the space occupied by them is one of the most intriguing and most hazardous correlations employed by

geographers. First used in 1837 ... it has since developed as a means partly of assessing overpopulation and underpopulation ... but mainly of obtaining an index for purposes of areal comparison'.

In this research, population density is not only employed as a means of areal comparison but also of temporal comparison: it is proposed to illustrate implied change in the British population by presenting a series of static maps of population density and allowing the reader to make comparisons and deduce change.

Population density has traditionally been calculated as the ratio of population to total land area. As a measure of 'overpopulation' (see above), the use of total area in the ratio is manifestly unsatisfactory and other denominators (the total number of rooms, area of cultivated land etc.) have been proposed. However, it is total land area which is used here, as the employment of other denominators does not necessarily solve all the problems and can introduce others at the geographical resolution of the data utilised. In this research, it could be argued that the measure of persons / room gives a better measure of the distribution of population, especially in the inner city areas. The use of such a ratio would indeed be possible if it were not for boundary changes in census collection areas. Such a ratio has been presented in census volumes since 1911 (Norris and Mounsey, 1982) but only for the areas in force at the time. The re-calculation of such ratios in a manner akin to that carried out on the total population data (described in chapter 4) was not felt to be reliable, an opinion also voiced by Baxter (1980,

pers.comm.).

It is the introduction of the variable 'area' into the calculation which gives rise to most of the problems associated with the use of population density. Statistics of population are traditionally presented by area. The size of these areas is either known, or can be measured if an accurate map is available (also pre-supposing the location of the boundaries is actually known). However, in reality, the distribution of the population forms an uneven statistical surface, and any such partition to bounded areas is artificial, done more often to suit the needs of administrators rather than those of analysts in general and demographers and population geographers in particular. Two problems arise from this partitioning, first, defining the location of such boundaries and, secondly, the variations in size of the resultant areas. The two problems are linked, but each is considered separately below.

Because the distribution of the population over the land surface is by no means even, any partitioning of this surface into areas results in units exhibiting inhomogeneity of varying degrees, the degree of inhomogeneity being dependent on scale. However, even with constant size areas, the location of the boundaries can have a considerable effect on population densities (as well as on relationships between different population characteristics - see, for instance, Openshaw, 1977). Consider figure 6.3, which is illustrative of this problem: figure 6.3.1 shows the density of the population as at the census of 1971: the

data were calculated using the population and areas of the counties then in existence. Figure 6.3.2 shows the density of the population in 1971, to the same vertical scale but using the population and areas of the counties as reorganized in 1974/5. These two SYMVU plots illustrate the problems both of boundary changes and scale (as first outlined in section 3.2.3). (1)

To examine first the problems of boundary changes, consider the case of the the city of Newcastle upon Tyne and the county of Northumberland. In 1971 (figure 6.3.1), the city was part of the county. The higher city densities are counter-balanced by lower county densities and hence the overall density is low. Boundary changes in 1974 led to the incorporation of the city within the metropolitan county of Tyne and Wear, together with the highly urbanised areas along both banks of the River Tyne (figure 6.3.2). The change in size of the county of Northumberland was not great (19,564 ha or 3.7% of the original county lost), but some 65% of its population was lost to Tyne and Wear, hence a lowering of the densities by a change in location of the boundary occurred. Similarly, the high increase shown along the banks of the river is due entirely to an alteration of boundaries, rather than rapid in-migration or natural increase.

The previous example does not involve an extreme alteration in size of areas, and hence scale. To illustrate the effect of

---

1 The plots are also a good example of mis-leading cartography in that no boundaries of data collection areas are shown. Accurate interpretation without this information is therefore extremely difficult.

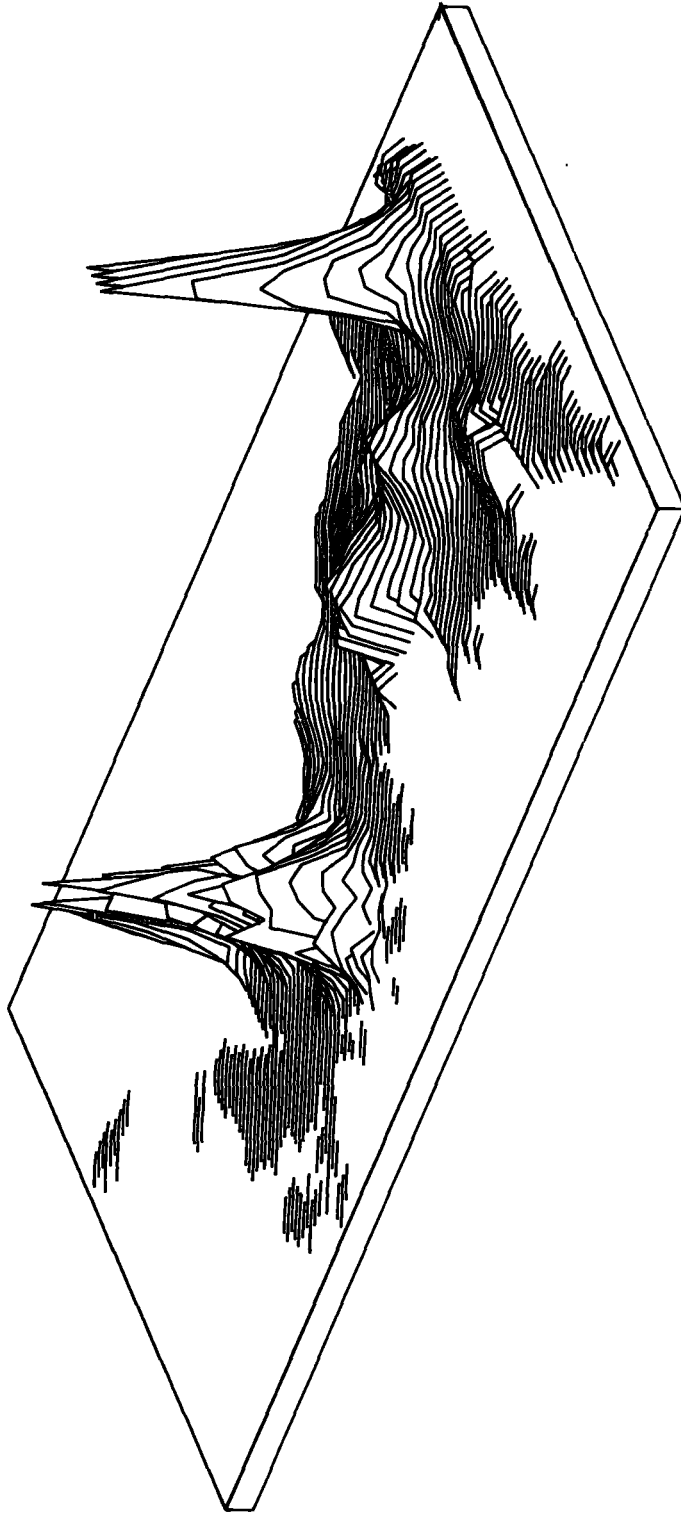

FIGURE 6.3.1: POPULATION DENSITY, 1971 (PRE-1970'S COUNTIES)

AZIMUTH = 45      TILT = 25  
AZIMUTH = 6.00      TILT = 3.00

\* BEFORE FORESHORTENING      JAN 27, 1982

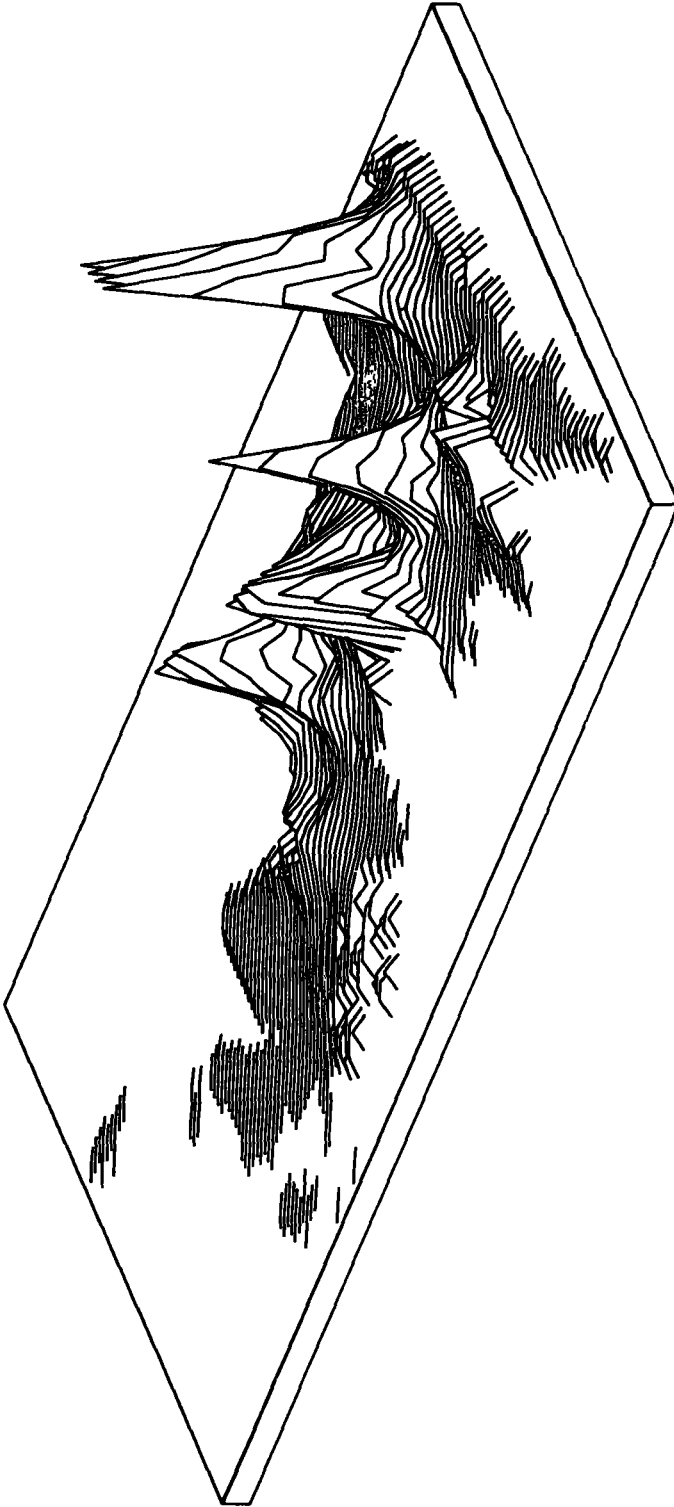

FIGURE 6.3.2: POPULATION DENSITY, 1971 (POST-1974'S COUNTIES)

AZIMUTH = 45      ALTITUDE = 25  
SCALE = 6.60      WINDSPEED = 3.00

BEFORE FORESHORTENING      JUN 27, 1982

alteration in size of areas, consider the case of the Glasgow area. In 1971 (figure 6.3.1) this was divided into the small, highly urbanised counties of Lanarkshire, Renfrewshire, Dunbartonshire and also the city of Glasgow itself, independent of any county. The calculated population densities are thus high, whilst those of the surrounding more rural counties are lower. On reorganisation in 1975 (figure 6.3.2), the city of Glasgow and surrounding areas, both urban and rural, became part of the much larger region of Strathclyde, which essentially represented a change in scale and a vast increase in internal inhomogeneity. Population densities fell owing to the inclusion of the rural areas surrounding Glasgow. The apparent decrease of the population of Glasgow is purely due to a change in scale since the data were originally identical (1971 Census SAS data). The smaller the scale, the more precise the location of the data and hence the more accurate the representation of the population distribution. Data for larger areas are merely at best 'weighted averages, with all the limitations that this term implies' (Clarke, 1972).

Given these limitations, then, is the concept of population density worthwhile? There is no doubt that

'the concept of density is itself an abstraction, its value being determined by the use of a limit area in density calculations which is appropriate to the map'.(1)

If it is possible to select the scale at which to calculate

---

1 Hunt, 1952.

densities, then it is certainly a useful concept. Clarke (1972) has argued that at a continental scale, conditions are so diverse that crude population densities are not comparable. At a national level they are comparable if physical conditions are not too dissimilar, but they are of most use in studies of much smaller units - the ward, parish or enumeration district. Hunt (1952) claims they may only be used if the areas by which the densities are calculated are 'very small' by comparison with the area of the whole map (although he does not define 'small').

In this research, the smallest unit available is the post 1974/5 district, some of which are large, and all of which show a great diversity of area and population (see tables 4.3, page 103, and 5.7, page 198). Given also that they are not very small in comparison with the area of the whole map (ranging between .0024% and 2.4% of the total land surface of Great Britain), their use would seem at least doubtful. However, the primary interest lies not in cross-national comparisons between districts, but comparisons through time for the same areas which allow patterns of population change to be determined. Hence the differing and sometimes large size of areal units assumes less importance in that at least they remain constant through time. There is little doubt that smaller units would be preferable in so far as they would give a more accurate picture: yet the data difficulties ensured that smaller units could not be used (chapter 4) and, in any case, the 'clutter' induced by large numbers of areas became serious (section 7.3.1). It was decided to incorporate these

administratively functional areas into a film of population change in Britain from 1901 to 1979.

How then should the concept of population density be used in an animated film? Since it is implied change that is being presented, in theory the simplest approach is to present a time series of static maps depicting classed population densities. The reader can then compare maps and deduce change in the population. However, though sound in theory, in practice this approach does not work. A change in the actual population of an area will not bring about an equally impressive change in its population density as this is a ratio, not an interval measure; the result is governed both by the population change and by the base population. Changes in population density tend to be small - over the period 1901 to 1979 the maximum absolute increase (density at 1979 minus density at 1901) was one of 35.7 persons / ha (LB of Barking) whilst the maximum decrease was -227.0 persons / ha (LB of Tower Hamlets). In comparison to the amount of change (which is small), the range of population densities in Britain is great - in 1979 these ranged from a minimum of 0.029 persons / ha (the Scottish district of Sutherland) to some 125.4 persons / ha in the LB of Kensington and Chelsea. Cartographic theory suggests such a range should only be divided to five or six classes at the most - indeed experiments confirmed intuition that, for successful viewing of an animated film, the number of levels should be less. Such a range divided (for instance) equally by five gives class intervals of just over 25. Hence

many districts would not change classes throughout the entire time period. Even if an attempt is made to take into account the highly skewed nature of the data set (the mean in 1979 being 11.67 persons / ha, and the range as noted above) by employing 'unequal' class intervals, the problem is still not resolved as the extremes of changes in density involve all densities throughout the entire range. Whilst narrow intervals at one end of the scale solve a problem here (areas may be seen to change density class), they exacerbate the problem at the other end of the scale where equal amounts of density change will not appear due to larger class intervals.

Why use class intervals at all? It is possible to portray population density by continuous shading (Tobler, 1973), but this invokes perception difficulties when used in static maps (Dobson, 1973), let alone animated mapping. The presentation of a series of density maps at two yearly intervals throughout the time period then is not a satisfactory solution to the problem of presenting implied change, there being little change in density in comparison to the actual range of densities encountered. Another problem related to the use of density maps in animated filming is summarised by Monkhouse and Wilkinson (1971)

^Perhaps the most obvious way of showing population growth is to prepare a series of maps in chronological order showing the past and present distributions. Such a series gives a broad picture, but it is a difficult task to measure and compare the growth of population from one district to another without recourse to a very close examination of the map^.

In an animated film, such close examination is not possible, except by 'freezing' of frames. Such action is possible with the use of video tape recording but, as discussed in section 2.4.1, the display resolution of this form of output is too coarse for the type of mapping used here.

In choropleth mapping, however, the concept of density has to be used (see section 6.1.1), so another method of presenting change in population densities is now examined. Stewart and Warntz (1958), amongst others, have shown change in population density to approximate to a series of concentric zones surrounding a city, radiating outwards from a central point, the city centre. Figure 6.4 shows the hypothetical distribution of population density across a city: it is highest, not actually at the city centre (the CBD) but just outside this, falling away in stages to the city suburbs. At this point (the distance of which varies in accordance with the overall population of the city), the density curve flattens out very rapidly. Stewart and Warntz term this the edge effect and argue it marks a transition from an urban to a rural environment.

The pattern of population growth and change throughout this century - at least up to 1971 - is well known: predominantly, it is one of migration from rural to urban areas, with two consequent effects. First, the density of existing urban areas has increased and, secondly, suburban expansion has occurred. An important exception to the first effect is the decrease in density of city centres - areas of Victorian high population

Figure 6.4: Population density around a city centre.

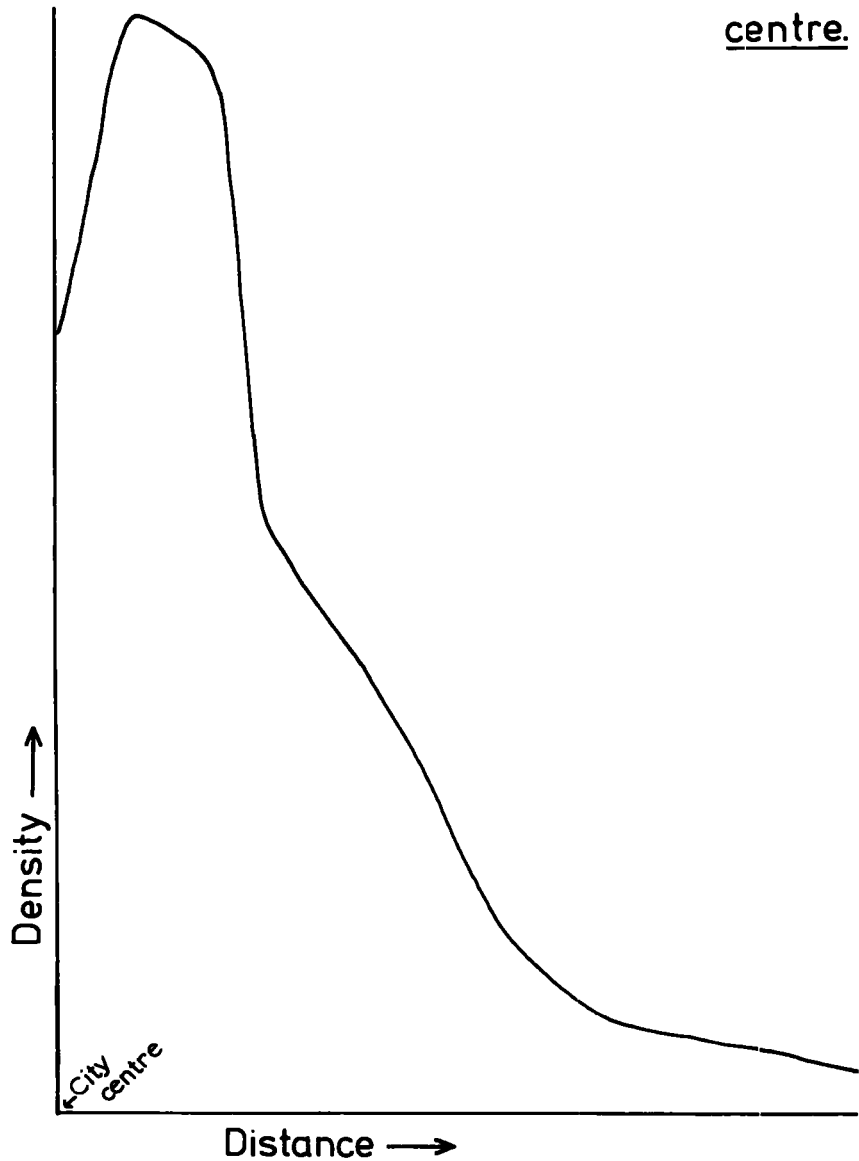

Based on Fig. 4, Rhind, Stanness & Evans (1977).

density, such as Tower Hamlets - contributing to the increase in overall ground area of the city by high out-migration. A time series of graphs as in figure 6.4 would show a movement of the 'edge effect' outwards as suburbanization (from out-migration and the decline in city centre population) results in the change of areas from 'rural' to 'urban'.

A method of mapping population change by population density may thus be proposed. If a series of maps are generated, each showing only districts above the critical density which separates urban from rural environments, then comparison of these maps should reveal change in the distribution of the population. For, as the film progresses, the shaded areas should expand as the density increases to over the critical point, and the district qualifies to be shaded. The maps are thus binary in character - areas above and below the threshold, rather than the more normal polychotomous classed choropleth maps. An obvious question now arises - what should this critical density be equal to?

Stewart and Warntz found in a study of the 1940 census of the USA that the step in the density curve occurred at some 2,000 persons / sq ml (7.72 persons / ha). However, they noted that such a figure could well fall due to increasing urban sprawl and consequent lower densities. Dixon (1972) has since noted it now lies between 0.8 and 8 persons / ha in the US. Comparable figures for Britain are difficult to obtain. O'Dell, in a map of

population distribution at the 1931 Census (1), groups areas with densities between 400 and 1,600 persons / sq ml (1.5 and 4 persons / ha) and terms them 'in transition' between rural and urban environments. More recently, the DoE (n.d.) have defined a de facto urban area as a group of wards or civil parishes with a minimum population of 2,000 and a density of at least 0.6 persons / ha together with one urban feature - a golf course, colliery etc. Such a density figure by itself is low, but it is set as such to ensure the inclusion of suburban fringes; the requirements of total population and urban features ensure the non-inclusion of rural areas (which can exhibit such densities). The use of such a density figure in this study would be misleading, if only because of the effect of geographical scale. It is impossible to apply the criterion of the presence of an urban feature - whilst many wards or civil parishes may be without one urban feature, it is extremely unlikely any district in Britain is found to be so.

In determining the critical density to be used in this research, it is important to note such effects of scale. Densities calculated at a ward or parish level are likely to yield a graph as in figure 6.4 when plotted: considerable homogeneity exists within such areas, and a wide range of densities results. However, at a district level, the range of densities is less due to internal inhomogeneity in these areas: an increase in scale ensures that the most densely populated  
1 1/lm scale, published by the OS in two sheets.

urban areas now include parks, industrial sites etc., whilst rural areas include local communities, causing a compression in the range of population densities. A cross-section of such densities when plotted does not reveal such a step in the curve, as fewer areas are predominantly urban or rural and more are mixed.

Figure 6.5 shows cross sections of population density, in both a N - S and a W - E direction across the Greater London area, and in a N - S direction through Greater Manchester, at 1901, 1921, 1951 and 1971, based on the data set described in chapters 4 and 5. The Y axis represents population density, and the X axis distance: the data are plotted at a point mid-way between the two district (or London borough) boundaries through which the transect passes.

Consider first the two graphs representing Greater London. These approximate very closely to the hypothetical distribution as shown in figure 6.4: lower densities at the city centre are seen, rising to the highest point just outside this zone, then falling away quite steeply to surrounding lower rural densities. Further, the graphs show the change in population densities through time. The rapidly falling densities of the city centre may be seen, and also a decline in the density of the immediately surrounding ring. The edge effect, whilst still visible, is lessening as suburbs of a much lower density expand outwards (e.g., Hillingdon, Broxbourne Croydon etc.). The transect through the Greater Manchester region, however, shows no such

**Figure 6.5.1: Population density through S.E. England (E-W)**

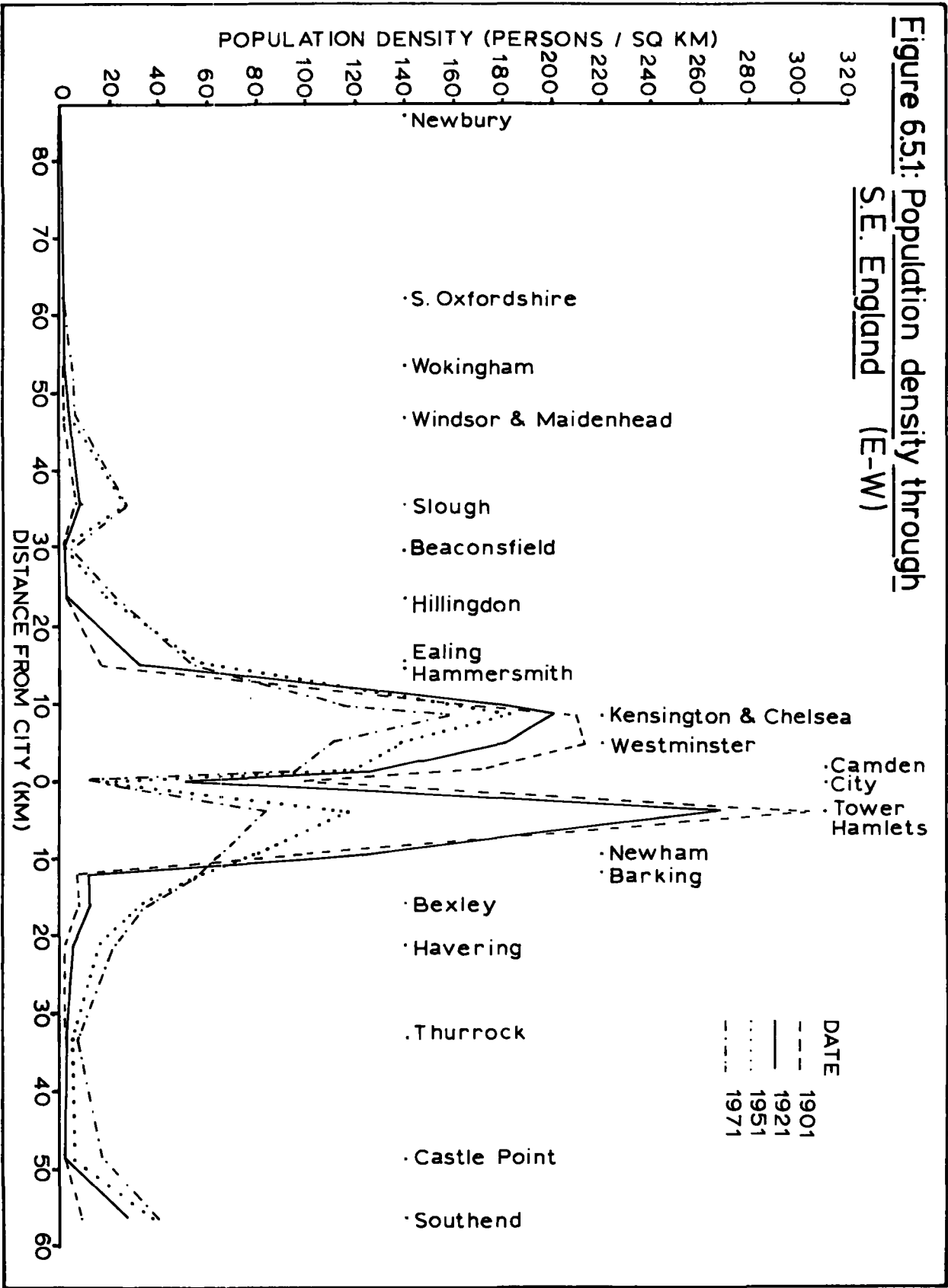
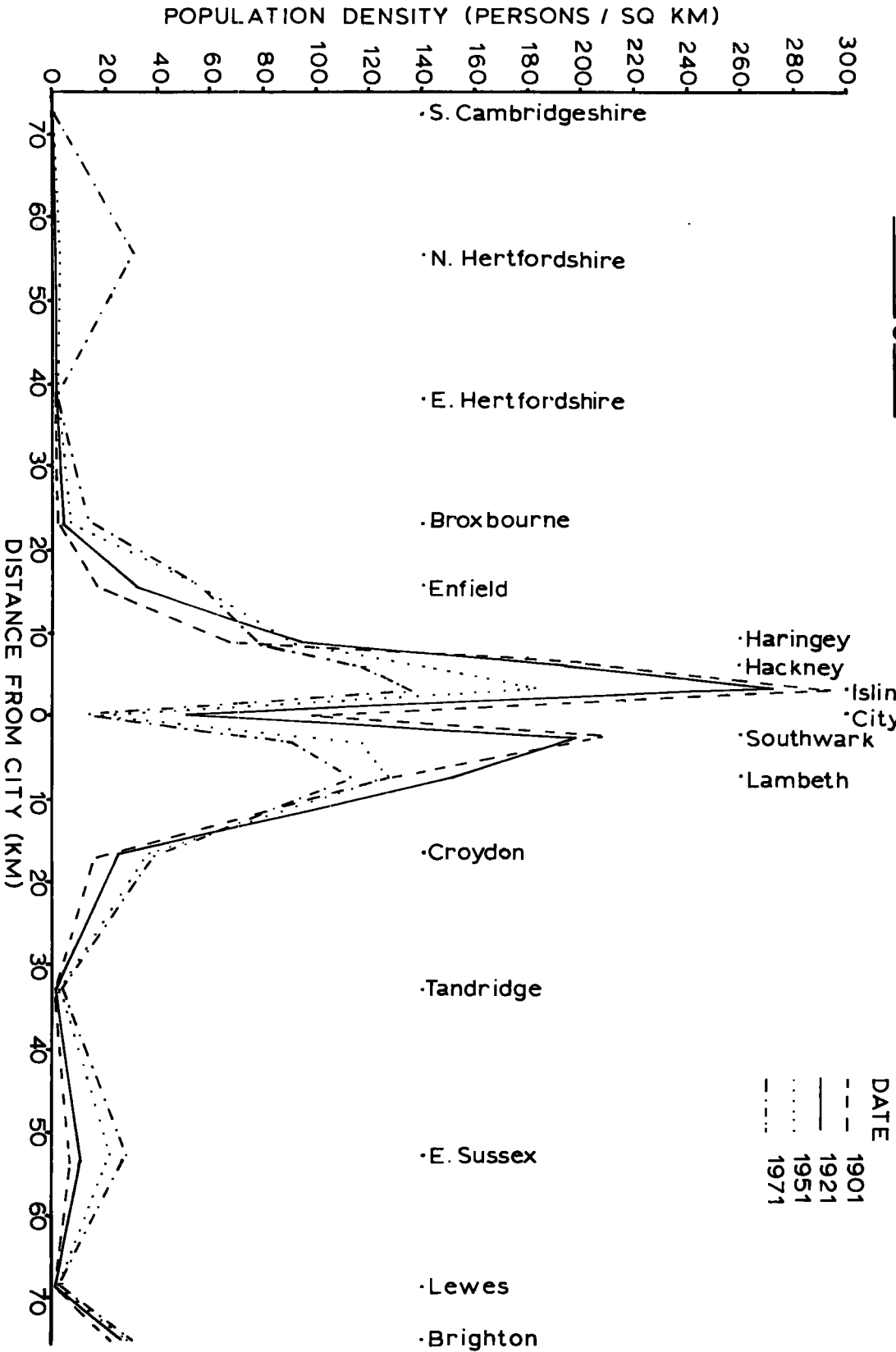
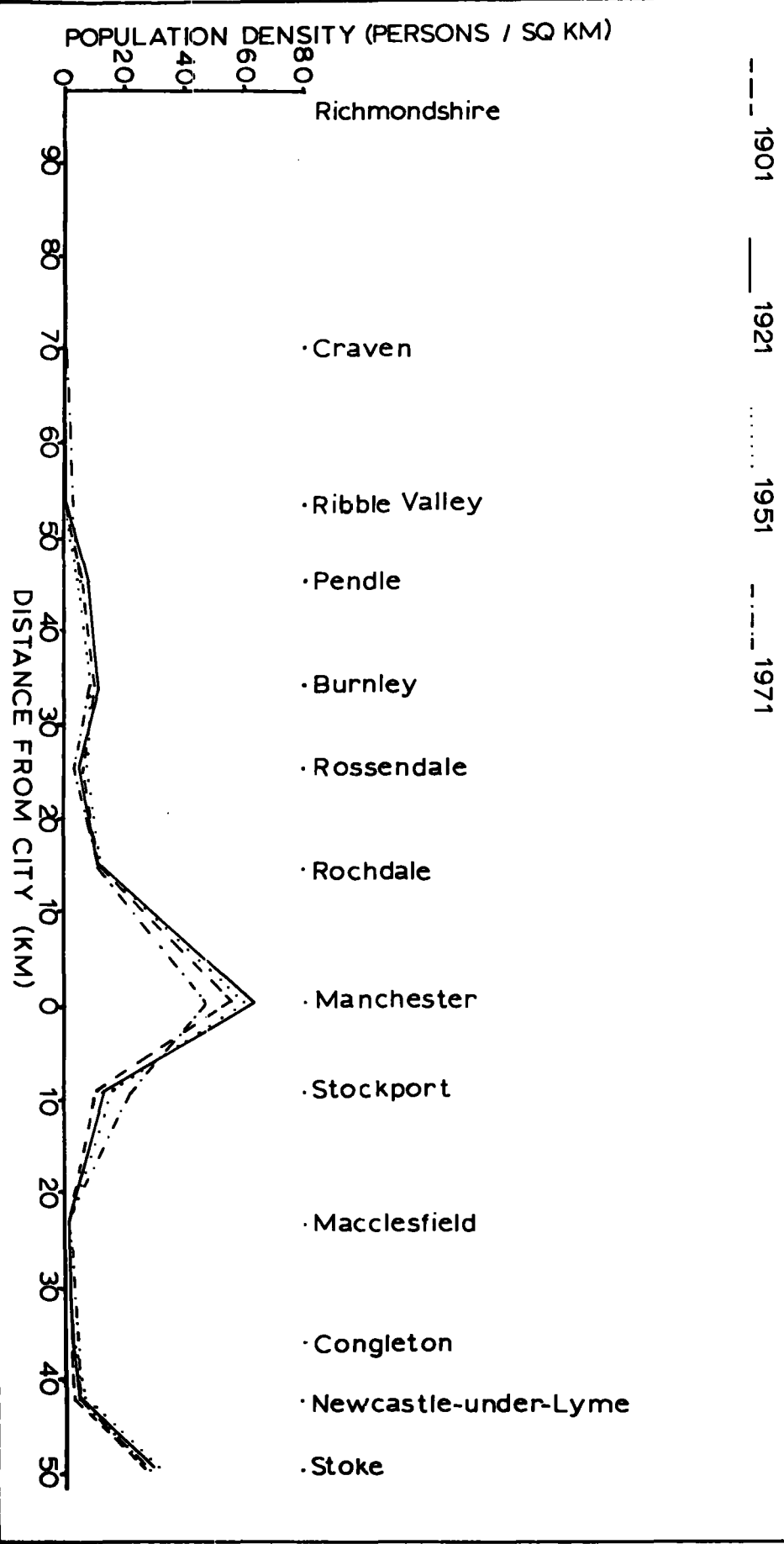

Figure 6.5.2: Population density through

SE. England (N-S)



**Figure 6.5.3: Population density through N England (N-S)**



features, except perhaps a lowering of the population density of Manchester and an increase in that of Stockport, again caused by out-migration from the cities to the suburbs; overall densities on the whole show very little change. The lack of a marked change in population density through space could be attributed to the fact that the districts are much larger in area, with a higher level of inhomogeneity than exists in the London boroughs. This, in turn, has the effect of lowering the peak population densities and losing many of the features seen on the London graphs. Such features could certainly be shown to exist across the Greater Manchester area, but only if a unit area smaller than the district were to be used. The comparative lack of change in population densities through time is due to the fact that the population of the North West has been very stable throughout this century - most change occurred during the 19th century and, subsequently, there has been no substantial in-migration to show increases in density as seen in the Greater London region.

Given that the use of district population density data - except in the Greater London area - may obscure the urban / rural edge effect, how may a critical density be determined? Figure 6.6 represents a graph of population densities of British districts which have been rank ordered. Two characteristics of this graph must be noted before its use is considered. First, it only includes districts with a density of less than 80 persons / ha. A number of districts (never more than 13) have therefore been omitted; without exception, these are London boroughs.

FIGURE 6.6: RANK ORDERED POPULATION DENSITIES, 1901-1971

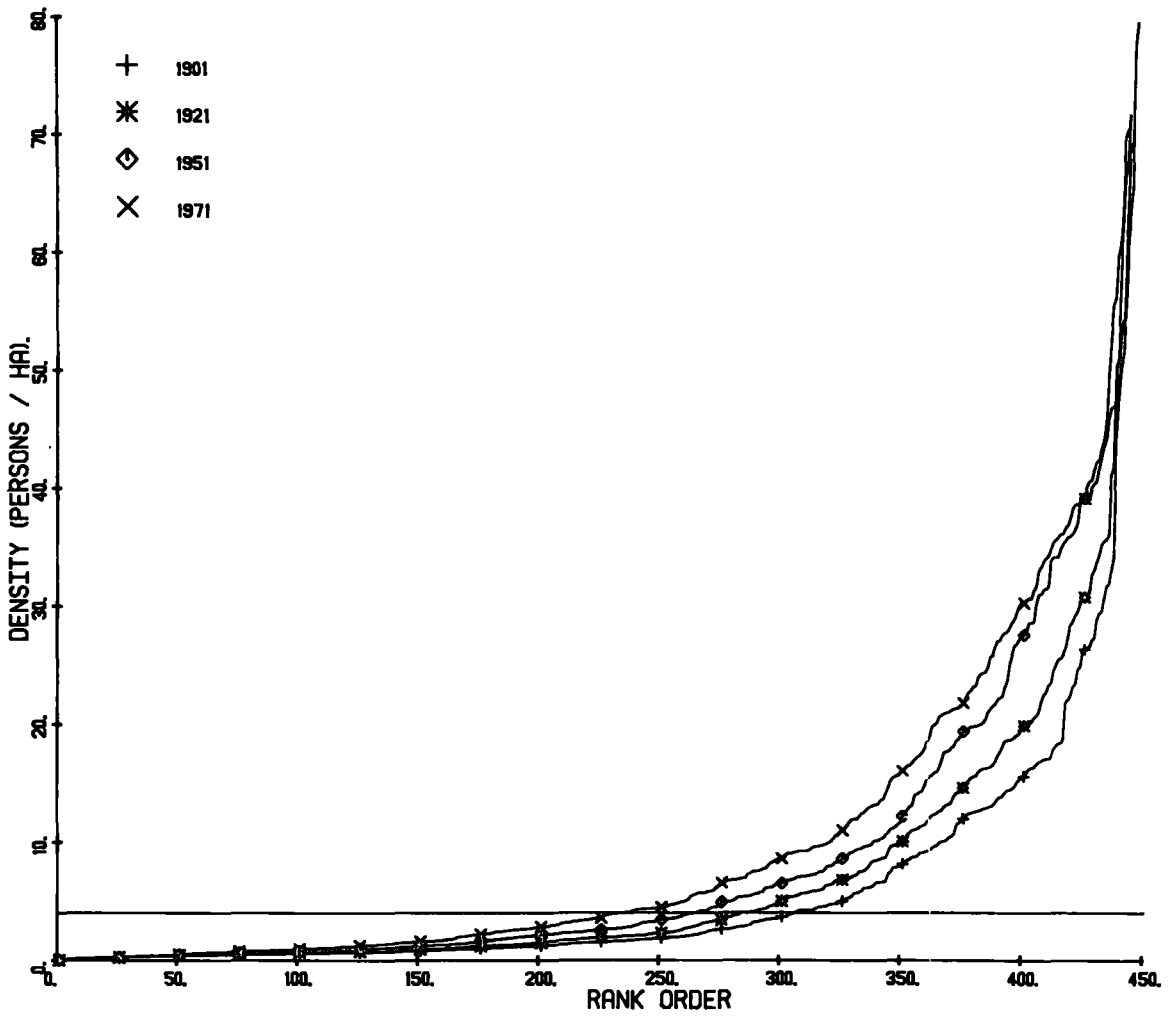

Secondly, the districts have been rank ordered by population density: it cannot therefore be assumed that (for example) the 350th district in 1901 is the same as the 350th district in 1921 nor can it be considered that increase in density in that area is given by the difference on the Y axis: no such specific assumptions may be made, and the graph is designed only to give an overall picture of density change nationally. The graph, however, shows an exponential mean increase in population density throughout British districts. Whilst there has been little change at either the top or the bottom end of the list through time, there has been a general increase in population density in mid-range.

On the graph, however, there is no marked step in the distribution of densities - the size of the districts ensures that they are never wholly urban or rural (with exceptions of some London boroughs) but most are, to a varying degree, mixed. Because of this lack of a step in the graph, a compromise selection of a density of 4 persons / ha as the critical point was made: the horizontal line on the graph indicates this level. A reasonable number of districts (87) pass through a density of 4 persons / ha in the period 1901 - 1979; it is high enough to exclude predominantly rural districts whilst low enough to include those more suburban in nature.

In summary, then, the method chosen to represent implied change was a mapping of areas with density of 4 persons / ha and over. Hereafter, this is termed the density section of the final

film. A density of 4 persons / ha is just over the average density of a populated 1 km grid square in Britain, and is therefore a reasonably stringent condition at district level given that, by the 'laws' of scale (section 3.2.3), densities should be lower. Thus, although this method shows nothing of population change in those areas consistently above or below such a density, it pin-points areas in transition through this density threshold. By shifting the threshold - a trivial operation - and repeating the exercise (perhaps over a more limited geographical area) it would be possible to examine the 'diffusion' of other population increases or decreases. Areas of population decline tend to be of two types: inner city areas where the density remains over 4 persons / ha throughout the period considered, and conversely, rural areas, where it never reaches the level of 4 persons / ha. Only very rarely have districts passed downward through a density of 4 persons / ha. Such districts tend to be those which maintain a density of about 4 persons / ha throughout the entire period from 1901 to 1979, and thus 'oscillate' through the threshold on several occasions (Durham and Dumbarton, for instance). The exception to this is Great Yarmouth: the change in the census date of 1921 (see table 5.3, page 161) temporarily increased the density to over 4 persons / ha, from which value it had declined by the census of 1931.

Before considering tertiary decisions made regarding the use of colour, layout etc. on the maps, it is necessary to examine one remaining secondary decision, namely the selection of a

method for the representation of measured change.

### 6.2.2 The representation of measured change

The representation of measured change involves first the calculation of a variable whose value is representative of population change in an area between two successive dates. If a series of such values are then presented in order via an animated film, some idea can be gained not only of short term change (as shown by each individual map), but also change over a longer time period (by the series of maps in sequence). There are a number of ways of determining such a variable, and these are now examined further.

Perhaps the most common method of presenting change in the population is by the calculation of a simple percentage change in population or percentage change in population density. Here, the difference in population or population density between the two dates is simply taken as a percentage of the population or of the population density at the first of these two dates. Despite the limitations of choropleth mapping, it is not necessary to use population densities if presenting measured change. The variable may be calculated directly from total population figures; dividing through the equation  $C = ((P_2 - P_1) \times 100) / P_1$  by  $A$  (where  $C$  equals change,  $P_1$  and  $P_2$  equal population at times 1 and 2 and  $A$  equals area) to account for densities does not materially alter

the results over several sets of such periods - it merely rescales them. Whilst one problem of choropleth mapping (the use of absolute numbers) is avoided, another remains. The larger of two areas in density shaded monochrome mapping which share the same class is visually dominant (although this need not be true for colour mapping). This becomes a particular problem when mapping local authorities in Britain which are very different in size: in addition, it is often the smallest and the largest of these areas which exhibit the extreme traits and are therefore likely to be shaded.

The first trial film to be made in this research showed measured change as depicted by the variable percentage change in population. It revealed a problem in using such a variable - indeed, one so severe that the method was not used again. Visvalingam (1978) has termed this problem the 'ratio effect'; it stems from basing any form of ratio (including percentages) on a set of areas widely differing in population size.

Clearly a change in population of the same absolute number will result in a different percentage change, dependent on the size of the initial population. Thus, an increase of 1,000 persons will result in a 10% growth on an initial population of 10,000, but only 0.1% growth on a population of 1 million. (Such hypothetical figures are not unrealistic: British districts vary in size from under 8,000, to over 1 million.) Conversely, a growth of some 100,000 persons is needed to produce a percentage change of 10% on an initial population of 1 million. It may be

argued that equal percentage growths have equal effects on the initial populations but, because of the large number of people involved in the latter case (and the likely increased diversity of social characteristics within such a population), the difference may be more important for many practical purposes. Most important, however, are the effects of chance variations, especially when change is being calculated on a population base at least partially devised by interpolation. In chapter 5, the generation of intervening population values between the decennial amounts derived from the census was discussed. The method used was to fit a cubic spline through a scatter of data points; the same 'shape' of curve will be fitted through an identical scatter of points on the graph irrespective of the order of magnitude of these points. Figure 6.7 shows two hypothetical sets of census populations for areas A and B, through which a curve is to be fitted and from which intervening population figures are to be interpolated, specifically for 1941. In any interpolated result, there is a certain amount of chance variation which will be equal for similar curves, irrespective of the order of magnitude e.g. a variation of 300 persons for the year 1941. However, an equal amount of chance variation (the value of which is unknown, and which cannot be separated from genuine change) will produce a different percentage value dependent of the size of the initial population - value  $V_i$  for area B represents a percentage increase of 28.20%,  $V_{ii}$  equalling 20.51%. For area A, the percentages equal 6.92% and 5.03% respectively. Hence chance variation has a

Figure 6.7: Population growth curves.

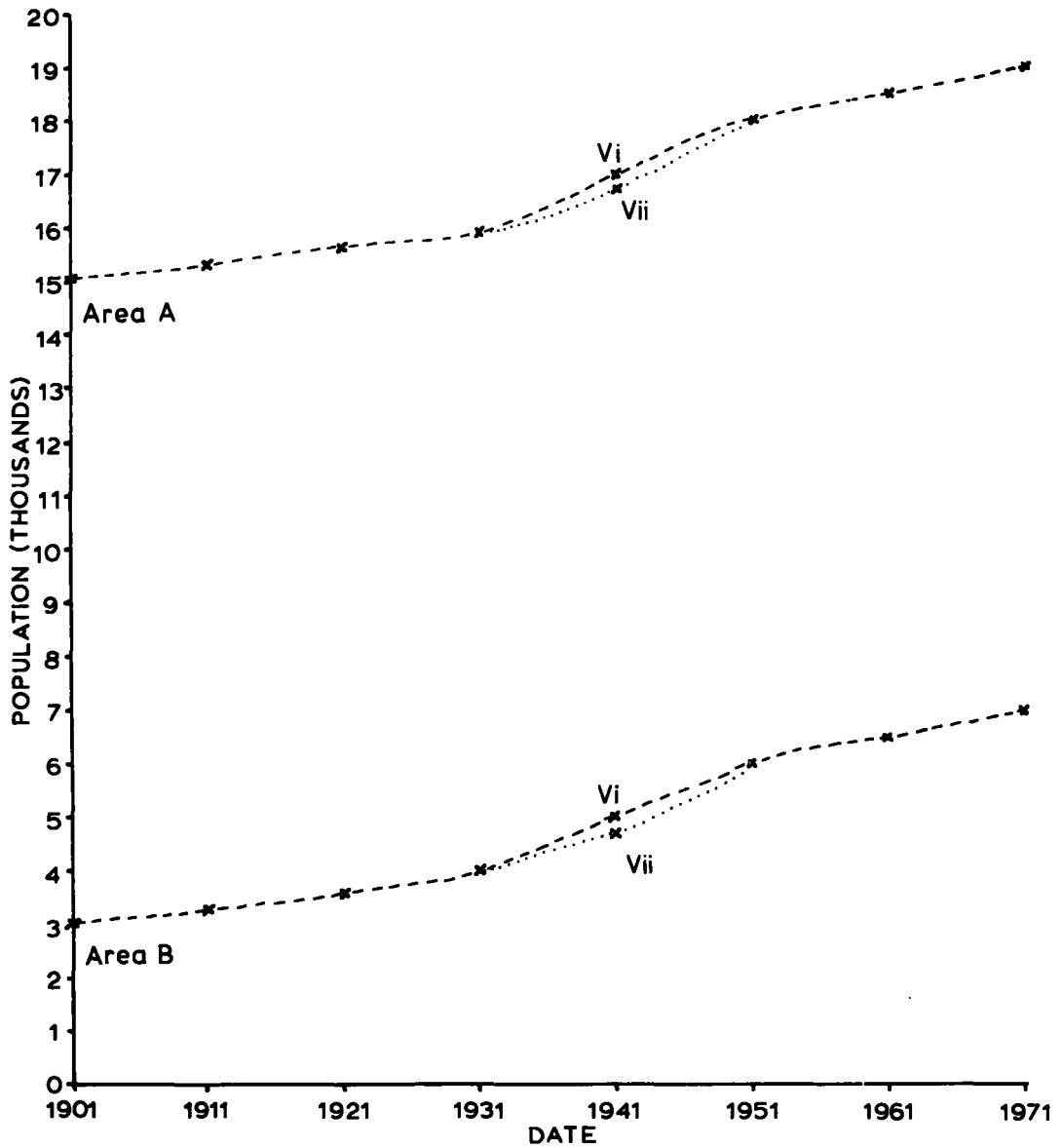

greater effect on smaller populations than larger ones.

A particularly striking example of this problem occurs within this data set, and concerns areas with very small initial populations in Scotland. Some of these areas have been much affected by oil developments resulting in a rapid increase of population during the 1970s. The method of interpolation by fitting a cubic spline has been shown to be at its weakest when interpolating through rapid increases in a data set; thus, whilst no doubt some of the change is genuine, part of the variation supposed to exist and shown by a high percentage change, could in fact be chance variation introduced when interpolating through rapid increase from a small initial population. This problem then has a marked effect if the results are used in an animated film. By portraying only areas above a certain percentage change cutoff point, the Scottish areas are shaded in some frames (high percentage change), but not in others. Thus there is a curious and distracting 'flashing' effect when the film is viewed. Furthermore, since the Scottish districts in question tend to be some of the largest in geographical extent in Britain, they dominate the map visually. The problem of the ratio effect undoubtedly occurs elsewhere in Britain at different times throughout the period 1901 to 1979, but is exacerbated in Scotland during the 1960s and 1970s by a high rate of increase, a low initial population and the use of cubic spline interpolation as compared with, for instance, least-squares based polynomial algorithms - other exact fitting algorithms would give a similar

effect.

An alternative, then, had to be found to the mapping of percentage change if measured change is to be shown on an animated film. The alternative devised was one based on a comparison between the actual population change and that expected by applying the national rate of growth to the population of an area.

In a study of population change in India between 1881 and 1931, Geddes (1942) proposed the use of an index of variability. Coincidentally, like the interpolation algorithm tested in section 5.4, this method was also devised by Aitken. Population change in India over this period of time was rapid, and the index of variability was designed as a more efficient measure than a simple expression of net population change. As Geddes noted: (p 563)

“Where a really large increase of population has taken place unaided by immigration, it can have been reached only by continuous increment. But where the population is the same as 50 years before, it may mean either of two things: a recurrence of disaster, where drought and famine or epidemic decimated the population, or a condition of real stagnation. In the former case decennial rates will show extreme variation; in the latter they will hardly vary. The index of variability is a means of revealing and measuring such contrasts”.

The calculation of the index of variability involves the fitting of a smoothed curve through the first and last of a series of data points, in his case the population totals of the censuses of 1881 and 1931. The method is limited in that the form of this curve must be determined by the user of the index; to this extent, results are therefore subjective. Geddes

proposed an exponential curve for the growth of the Indian population: in a later work on the United States (Geddes, 1954) he fitted a straight line, this being supposedly more representative of the pattern of US population growth. The deviation of the remainder of data points from this curve is measured and averaged. The mean deviation is then expressed as a percentage of the mean of the first and the last population figures. Areas showing a steady growth in population (irrespective of rate) will show low percentage variability; conversely, areas of high percentage variability have experienced uneven growth.

A major limitation of this method is that it can only be applied to population change over a prolonged time period. It is not suited to animated filming as only one measure of change covering a number of years is calculated. Furthermore, the selection of a representative curve to fit through the data makes the method subjective. However, the idea of deviation from a standard or expected curve is one the present author felt worthwhile, and needed further development to enable not one, but a series, of measurements to be derived over a time period in order to construct an animated film.

The method developed was based on one used by Visvalingam (1978), i.e., the signed chi-square statistic. This measure had been developed for use in grid square statistics from the 1971 Census of Population: within this data base, the range of total population figures is much greater than that found at the

district level and problems introduced through the ratio effect correspondingly even more severe. The signed chi-square statistic can 'discriminate over the entire range of values by making suitable but consistent internal adjustments' (Visvalingam, 1978); the effect of small population bases is lessened.

The classic chi-square statistic tests the observed distribution of individuals against an expected distribution. It may be derived as follows

$$\chi^2 = \frac{(O-E) * (O-E)}{E} = \frac{(O-E)^2}{E}$$

where O = observed frequency at any one point within the distribution and E = expected frequency at the same point. The result represents a measure of departure from the expected; subject to the data meeting the appropriate assumptions, tests of probability may then be carried out at differing levels of confidence to assess the significance of the result.

For the research in hand, the classic chi-square statistic was modified, although the idea of taking into account both the absolute (O-E) and the relative ((O-E)/E) deviation from the expected was maintained. In order to obtain a measure of population change, the calculation ((O-E)\*\*2/E) was performed for each area, over each two yearly period (1901 - 3, 1903 - 5 etc.). O was determined to be the actual population at the end of the period, whilst E was calculated and dependent upon the national

population change over the same time period. The national percentage change was applied to the population at the beginning of the time period and the resultant figure substituted for E in the equation. Table 6.1 shows not only the application of the method, but the effect of the size of the population base. Given an equal percentage increase in population, areas with a larger initial population will return a higher chi-square value than those with a smaller population.

In considering population change, it is useful to know whether the population of an area is declining or increasing in relation to the national average. (It must be remembered that declining areas can still be increasing in population, but only at a lower rate than the national average.) In order to give an idea of direction, Visvalingham (1978) developed the signed chi-square statistic. Here, the sign (+ or -) of the calculation ( $O - E$ ) is maintained and applied to the resultant chi-square figure. This principle was applied here; table 6.2 shows the results.

These two tables serve to demonstrate the effectiveness of the signed chi-square statistic. The same relative increase is rated more important in a larger population (see table 6.1). Conversely, the same absolute increase is more important in a smaller population. Furthermore, the 'direction' of the population change in relation to the national change can be identified by the use of the sign of ( $O - E$ ).

Some 39 values of the chi-square statistic were calculated for 458 areas, representing change over two-yearly periods from 1901

Table 6.1: Application of the chi-square measure.

Assuming a national percentage increase of 5%, and an increase by individual areas of 6%.

Population O(=6%) size	E(=5%)	Diff.	Diff <sup>2</sup> .	/E(=χ <sup>2</sup> )
100	106	105	1	9.52x10 <sup>-3</sup>
500	530	525	5	4.76x10 <sup>-2</sup>
1000	1060	1050	10	9.52x10 <sup>-1</sup>
5000	5300	5250	50	0.476
10000	10600	10500	100	0.952
50000	53000	52500	500	4.762
100000	106000	105000	1000	9.523

Table 6.2: Application of the signed chi-square measure.

Assuming an absolute increase of 500 persons in all areas and a national increase of 5% overall.

Population O(=+500) size	E(=5%)	Diff.	Diff <sup>2</sup> .	/E(=χ <sup>2</sup> )
100	600	105	495	2333.6
500	1000	525	475	429.7
1000	1500	1050	450	192.8
5000	5500	5250	250	11.9
10000	10500	10500	0	0
50000	50500	52500	-2000	4m.
100000	100500	105000	-4500	20.25m.

to 1979 inclusive. The data set ranges from -4.304 (the city of Glasgow, 1971 - 1973), to +18.303 (Harlow, 1951 - 1953), although 99.2% of the values in the 39 by 458 matrix fall within +/- 1.0. In order to map these data, it was decided to concentrate on the two extremes of change, selecting cut-off points outside which to shade an area. The two cut-off points were selected at -0.05 and +0.05; again this was partially an arbitrary selection, but, when tested, it was felt to give a reasonably accurate picture of population change over any one time period because a sufficient, but not overwhelming, number of areas 'changed state' in the time period as a whole; it is technically easy to re-compute the maps with different cut-offs. The film made which utilizes these data is hereafter referred to as the 'chi section' (c.f. the 'density section' in section 6.2.1). (1)

### 6.3 MAP DESIGN

Once the map type (see section 6.1) and map contents (section 6.2) are known, these decisions may be tied together in the process of map design. This is probably the most critical stage in the entire map making process for, if the map is badly designed, regardless of the accuracy of the contents it will fail in the ultimate objective, that of communicating the information

---

1 The two sections were combined to form the final film enclosed with this thesis.

contained therein to the map reader. The design of choropleth maps for animated filming is probably more difficult than the design of any other maps, simply because such a technique had not otherwise been used - there were no previous guidelines to work from and many unknown factors. In the following section, then, the basic principles involved are discussed. The final section examines actual design of maps for animated filming. However, it is necessarily brief, as many of the actual decisions regarding the use of colour, etc. were empirical and rested on the results of trial films, the making of which is described in the next chapter.

Given a set of inputs to the map-making process (topographic and thematic data), the resultant 'image' a map presents to the map reader is a result of a complex interaction of several 'graphic elements'. With reference to an individual map, Robinson et al (1980) have described these as clarity and legibility, visual contrast, balance, figure-ground relationships and colour. Each of these elements is under the control of the cartographer who may adjust each one until the desired image is obtained, hopefully one which conveys a true and accurate message to the map reader. This, however, is a somewhat ideal situation and, in reality, a cartographer attempting to produce the desired image is often working under a set of controls such as the objective of the map, 'reality' itself, the scale, the intended audience and technical and resource limitations. In effect, then, a cartographer is attempting to design a map by juggling a

series of graphic elements all under the influence of a set of controls. Obviously both the controls and elements interact with each other, but they are now considered individually.

The most important of the set of controls which may prove a limiting factor in map design is that of the objective itself. Quite simply, it is easier to design a map showing the distribution of one phenomenon than a map showing the distribution of many. A map which seeks to achieve many objectives requires greater planning on the part of the cartographer as regards layout, symbolism and shading, etc. if it is to be successful. In this research, the objective is a simple one: to portray population change between 1901 and 1979. This in itself is not an important control in that it is not difficult to portray population change as such. Greater controls are placed upon the cartographic design process by reality, scale and technical limitations.

Reality acts as a control in that it cannot be altered by the cartographer: for instance, the shape of areas is pre-determined (though some generalisation may be acceptable), as is the past distribution of phenomena throughout time. Thus, portrayed in conventional form, Great Britain maps only to a tall and narrow rectangle. Furthermore, the size and shape of the areas used within Great Britain are markedly different, and (inevitably) it was within some of the largest and the smallest of these that the most significant changes in population occurred. Linked to this is the control exercised by scale: a map which, in order to fit

the desired output medium, is at a very small scale requires quite different design strategies to a map drawn at a larger scale. The plotting of Great Britain on an animated film is necessarily at a small scale, although the final display is at a much larger scale. This then affects not only the amount of detail which may be shown, but also the way in which it is shown (in the use of colour, symbolism etc.).

The intended audience for any cartographic product can control map design in that they show very different perceptual limitations, and actual needs. Maps designed for young children must be very simple (Sorrell, 1974), whilst the requirements from any one topographic map of an area by a motorist or walker will probably be very different - see for example maps of road speed by Morrison (1971). Although the animated films in production were not destined for a specific audience, it seemed highly probable that amongst the audience, there would be those with relatively undeveloped map-reading skills. Furthermore, no research is known to have yet been carried out into the perception of animated films. For all these reasons, then, it was though best to aim for simplicity in both content and design.

The final control, that of technical limitations, is perhaps the most important one in this research in that it concentrates on a new cartographic technique heavily dependent on automated rather than manual methods. The maps had to be designed for a fixed output medium which incorporated certain limitations regarding the size and use of colour, the minimum width of lines

which could be drawn and so on. Other hardware and also the software used in the process imposed some technical limitations. Since the system is described in chapter 7, it would be out of place to discuss such controls here: they will become apparent to the reader throughout the following chapter.

The overall controls on the map design process in this research are thus represented by reality, scale and technical limitations. None acted individually: rather a combination of these controlled the design process. The question to be answered at this stage is how to portray population change in Great Britain over the period 1901 to 1979, given these controls.

If a successful answer is to be provided in the form of a well-designed map, then each of the graphic elements of such a map must be considered. As with the operating controls, they all interact but it is simplest to consider them individually.

Clarity and legibility. In order to be interpreted correctly, a map must be both clear and legible. Whilst this goes for all maps, in animated filming it is of particular importance due to the motion of the film. An unclear or illegible symbol on a static map may become clear and readable after some period of study. However, on an animated film, such a study is not possible: information must be interpreted immediately or else it is gone. Scale acts as a control on clarity and legibility and especially in animated filming. Whilst the actual size of the image on film is constant, that seen by the audience will be determined by the relative location of the projector, screen and

audience: the further away a projector, the larger the image for a constant focal length. Yet the audience can be anywhere between the projector and the screen, thus viewing distances for any one film - unlike those for traditional maps - can vary widely and, whilst 'absolute' symbol size is constant, 'relative' symbol size varies. The symbol size must therefore be large enough to allow for such variations. Furthermore, viewing conditions themselves affect clarity and legibility. At a given viewing distance, a symbol 'in motion' needs to be larger than that on a real map: the factor by which it is increased in size is not known nor was much information available on this ratio at the outset of this research.

Visual contrast. Robinson et al (1978) have argued visual contrast to be the most important graphic element. For, irrespective of size, if a symbol is to be seen it must contrast with the background, and with other surrounding symbols. Visual contrast must be emphasised in animated filming as a symbol must be immediately obvious; the map reader does not have time for conventional visual search processes (Audley et al, 1981) to determine, for example, the location of the boundaries of the area as in a static real map. Visual contrast is closely related to colour (see below).

Figure-ground. The figure-ground phenomenon is perhaps the most complex aspect of human perception. It represents the ability of the eye (subconsciously) to determine within an image which is foreground (figure) and which is background (ground).

From here the viewer will go on to interpret the foreground, whilst disregarding the background. Figure-ground perception depends on a number of factors. Generally, darker areas will emerge as figure whilst lighter ones recede as ground (Robinson et al, 1980). However, closed areas, irrespective of colour, will tend towards figure, as will areas in which there is additional information (internal boundaries, symbolism etc.). The figure-ground phenomenon is especially important in animated filming in that the viewer's eye must be drawn immediately to the figure: the background must be extremely simple.

Balance. Any map must intuitively 'look right' or appear balanced and pleasing to the eye; nothing must appear out of place. Balance is achieved by 'good design' of map layout, and is generally the first stage in the map design process. Unlike the foregoing factors, balance does not change between an animated film and a static map. In either case it is heavily controlled by reality: if the shape of the area to be mapped is awkward, careful design of map layout is required to achieve a balanced map. 'Balance' is essentially a qualitative phenomenon; it is extremely difficult to codify rules which ensure 'good balance'.

Colour. Subsequent experiments (see section 7.3.2) showed colour may be used to good effect in animated filming. It may be possible to portray a distribution on a static map in monochrome as the reader has time to assimilate the image. However, greater flexibility is possible with the use of colour symbolism, and

visual contrast can be increased. Whilst the use of colour enhances animated mapping, it must be used with care. Symbols must be of constant hue, varying only in brightness (see Kolers and Von Grunau, 1976). For, if they vary in hue, the phenomenon of persistence of vision (on which the motion of the animated film depends) does not hold (see section 2.1).

In summary, then, it would seem the cartographer designing an animated film has to aim towards extreme clarity and simplicity in order that the contents of the film should be seen and understood. The aims of clarity and simplicity are, in this research, subject to the controls of reality and scale, and technical limitations. The remainder of this chapter discusses the preliminary design of maps for an animated film: decisions made on the basis of the results of trial films are discussed in the following chapter, along with the actual system used to generate the films.

### 6.3.1 Map design in practice

The first stage of map design is the planning of the layout of the map. This was the only stage completed without the use of trial films, and was carried out using hard copy pen plots. In view of the aims of clarity and simplicity, it was decided only to include three items in any one map: the area itself, the title and the key, all surrounded by a single 'neat-line' frame. The

layout of these three items is now considered: a key factor is the aspect ratio, the ratio of the width of the map frame to its height.

In order to achieve a balanced map, Karssen (1980) has suggested a rectangle with an aspect ratio of 5:3 (or 3:5) to be most stable and pleasing to the eye. It is here, however, that reality exercises its first control. For a frame which will enclose a map of Great Britain with every part at its correct geographical location has an aspect ratio of approximately 2.1:1. This frame is very long and narrow, and certainly not pleasing to the eye. (Figure 6.1 illustrates this layout.) Fortunately the most northerly part of Britain (the islands of the Orkneys and Shetland) are relatively easy to inset. The concept of inseting is often frowned upon by cartographers as it destroys part of the accuracy of the map - everything is not then in its correct geographical position. However, in this case, it was found by experiment that by inseting the Shetlands in the north-east corner of the map, the aspect ratio of a frame needed to enclose the map was now reduced to 5.2:3, much nearer to the ideal as proposed by Karssen. Figure 6.2 shows this layout; in it, not only are the Shetlands removed from their correct location, but also the map reader has no means by which to locate them correctly (grid references are not included in the map, neither is any part of any other land mass included in the inset to assist in relative location). The system relies on the prior knowledge of the map reader both to recognise and correctly to

locate the islands. A second disadvantage of inseting the Shetlands in this particular case is that space which could be used for the title or legend is otherwise used, leaving less room for these two items. However, it was felt the advantages of having a balanced map over-ride the loss of space and incorrect location.

A further advantage of using the above layout is concerned with the placement of the map on the output medium. There are two modes in which an image may be positioned on a film, comic and cine. Figure 6.8 represents the difference between the two. Comic mode is generally used only in microfiche recording: if the material is recorded in this mode for subsequent projection by other than microfiche, the image will appear rotated through ninety degrees, i.e., it is 'sideways on'. Recording material in cine mode, however, preserves the implied time sequence in successive frames on projection and the image is seen the correct way up. There is a problem, however, as illustrated in figure 6.8.3. The aspect ratio of the output medium in cine mode is the opposite to that of the maps (irrespective of size) - the longer side of the map has to be scaled to the shorter side of the output medium frame. It is apparent then that the shorter the Y dimension of the map, the greater the actual size of the image on the output medium as the scaling factor is less. Unfortunately, irrespective of which layout is chosen, the scale of a map of Great Britain drawn in cine mode is smaller than that in comic mode since the map does not fit the page so well: decreasing the

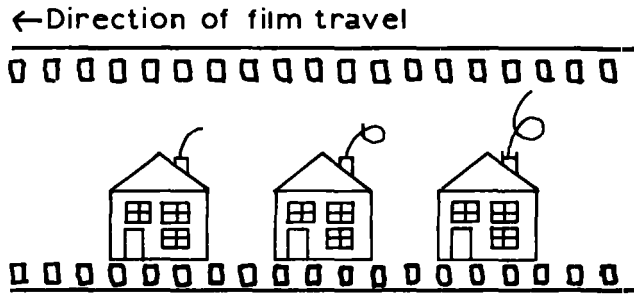

Figure 6.8.1: Comic mode

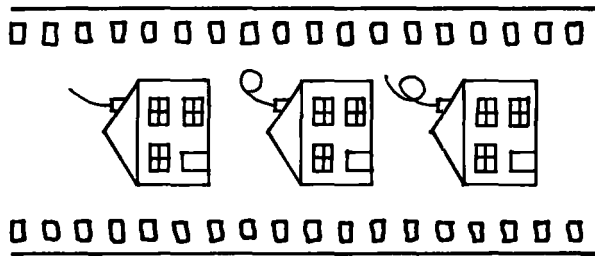

Figure 6.8.2: Cine mode

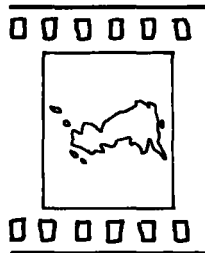

Figure 6.8.3: Great Britain shown  
in cine mode

scale increases the problem of clarity and legibility, especially when considering the already small size of some local authority districts in Britain (the London Boroughs, for instance).

Thus a general layout which, hopefully, appears balanced can be designed: most of the frame is occupied by the map of Britain, with the Shetland Islands removed from their true position and inset within the north-east corner. Below this inset is space to be used for a title and a legend to the map. What form the title and legend should take, and how exactly the data should be portrayed on the map were all the subjects for experiment, the results of which are discussed in the following chapter.

## 7 FILM PRODUCTION

This chapter examines the generation of the film itself, using the design strategies as outlined in chapter 6 and operating under such controls as noted therein. It is divided into four sections: the available technology and computer resources necessarily had a marked impact on the final form of the film and the first two sections describe the relevant facilities at NUMAC (the Northumbrian Universities Multiple Access Computer), and at the Rutherford Laboratory; the last two sections describe the generation of trial films and the final production runs.

The generation of this animated film was, so far as map-making is concerned, a new process and one which necessarily relied heavily on much empirical experimentation. To this point, all that had been determined were the contents of the film, and a rough layout of each map. It was also assumed that output would be to a microfilm plotter rather than video, the former having the advantage of greater resolution, good registration etc. Questions on where the maps were to be produced, and their exact design, still had to be decided.

The only colour microfilm plotter in Britain available to the author (indeed, the only one known in the country) is the FR80 at the SERC's Rutherford Laboratory. This plotter is described in greater detail in section 7.2.1. Initially, it was intended to generate the maps on the IBM 360/195 computer at the Rutherford Laboratory, and plot them on the nearby FR80. This course of

action would have minimised delays from tape transfer problems, etc. This approach was abandoned for four main reasons:

1. It would have necessitated mounting GIMMS (see section 7.1.2) or a similar package on the Rutherford Laboratory machine.
2. It would have necessitated either heavy use of a computer link to plot out sampled test frames prior to plotting on the film or, alternatively, to have involved delays of perhaps a week or more prior to each experiment while waiting for the results to be returned via the post.
3. No genuine interactive facility was available at the time on the Rutherford Laboratory machine.
4. Though the research was SSRC-funded, SERC would have charged the author at external user rate for any significant amount of computing. In contrast, computing power in Durham is essentially free to bona fide researchers.

For these reasons and because the author had already mounted earlier versions of the necessary software on the local computers, a different procedure was investigated, viz., to mount on the NUMAC IBM computer the Rutherford Laboratory software for driving the FR80 plotter. In the event, this also proved untenable since the software assumed the presence of parts of the

Rutherford Laboratory system library. The solution finally adopted was to:

1. design, create and test sample frames of the film using a Tektronix 4014 storage tube CRT linked to NUMAC
2. create a local plot file of the maps
3. send this to the Rutherford Laboratory and convert it on the IBM 360/195 to the commands used in their plotfiles and
4. send the results for plotting on the FR80.

Full details are given below about the facilities used.

## 7.1 FACILITIES AT NUMAC

This section is divided into two parts: an examination of first the hardware and secondly the software available at NUMAC.

### 7.1.1 Hardware

Throughout this research, computing at NUMAC was carried out on an IBM 370/168, sited at Newcastle. This is a large mainframe

machine with eight megabytes of memory, running both in batch mode and interactively under the operating system MTS (Michigan Terminal System). Up to 200 terminals and a number of batch stations and plotters are on-line at any one time. Access to this machine from Durham was through a variety of terminals linked via a Post Office line.

The nature of the IBM 370 when allied to MTS made the machine well suited for cartographic purposes. Furthermore, MTS is a very simple operating system to use (unlike OS at the Rutherford Laboratory). The interactive facilities allow for the design and viewing of maps, whilst the longer production runs could be carried out in batch.

Terminals used in Durham included a Tektronix 4014 with high resolution graphics (4K addressable points in both X and Y): this is a 14 inch storage cathode ray tube, well suited for the interactive design and plotting of maps. Also used were various drum plotters, notably a 30 inch four-pen model: this was used to produce hard-copy output of maps in up to four different colours.

### 7.1.2 Software

Given the local facilities, there were few hardware limitations to the production of a series of maps necessary for the film. In contrast, there were major problems arising from the lack of a suitable program for choropleth mapping at NUMAC.

The package SYMAP had been available for some years but, although Massey has constructed an animated film using this program (see section 2.4.3), it is too unsophisticated in output for the envisaged purposes and is essentially outdated - vastly superior packages were known to exist (see IGU, 1981). Some user-written programs were already available such as LASERMAP (Rhind, Evans and Visvalingham, 1980) but these tended to be written with a particular aim in mind, and not for general choropleth mapping. There seemed to be no program available for choropleth mapping which would provide the flexibility necessary for experiments in animated filming (requiring a number of text fonts, the ability to position and change the size of text, and a wide variety of symbolism for instance). This gap then left two options open to the author: either to write her own suite of programs or to implement at NUMAC an already existing and suitable package from elsewhere.

Since such packages often involve many man-years of work and since the objective of the research work was not to produce a new computer package, the latter solution was chosen. There are a number of packages available which will perform choropleth mapping - Calform (Anon, 1972), GIMMS (Waugh, 1980), Wismap (van Demark, 1977), etc. The package GIMMS (Geographical Information Manipulation and Mapping System) was chosen for implementation at NUMAC. This involved acquiring some understanding of the 30,000 line long program, some re-writing of the subroutines and significant effort to interface it to the local plotting library,

but the amount of work involved was very much less than the amount of programming which would be needed to create a new program comparable in facilities and length to GIMMS.

GIMMS itself is a multi-purpose mapping package, covering all aspects of thematic map design and production (Waugh, 1979). It allows for the input of both topographic and thematic data, the manipulation of thematic data, the interactive design of a map combining both sources, and the final output of a very high quality cartographic product. Parts of the package, written in Fortran, were originally programmed in 1970; Waugh (the author) has chronicled its development since that date elsewhere (Waugh, 1980) and the versions described here are the two which were mounted by the author between 1978 and 1980.

GIMMS is a very general system which may be run interactively or in batch: it can deal with any type of point, line or areal data (but not with volume data). Output can be in a wide variety of forms - dot symbolism, point symbolism (both single and multi-component), choropleth symbolism and - in the latest version - basic line symbolism in the form of arrows. It cannot yet produce isoline maps, nor any form of dasymetric mapping (but since the author had already decided to use choropleth symbolism, these were not limitations). A problem associated with its very general nature is that it is less computationally efficient than a program designed specifically for that purpose would be, but this problem is more than offset by the extreme flexibility offered in interactive map design - a very necessary feature when

little is known about the limitations on design of the output map and much work has to be done by trial and error. Such flexibility in design is achieved through an extremely good user interface. Input is by a series of free format commands - there were over 70 of these in the first version of GIMMS mounted at NUMAC, and more in the second. The general structure of these commands are described in Waugh (1978). Most commands have several options associated with them, thus the number of parameters which may be set by the system exceeds 700 (Waugh, 1980). Each option has a default value, so the system is comparatively easy to use by a beginner wishing to produce simple maps, but also allows the production of very high quality and tailor-made output as and when needed.

An important side effect of the implementation of GIMMS by this author at NUMAC was its availability to other users, aided by its simplicity of use. Numerous other users benefitted from the author's work and, in turn, shared their experience of use of the package. As well as producing maps for the films, GIMMS has also been used for the large scale production of maps of employment in Northern England (Owen et al, 1981), for maps of social and economic conditions within the EEC, and in a variety of other projects and research theses. Over 1,000 maps apart from those drawn for this thesis have been produced by other members of the Geography Departments at Durham and Newcastle Universities.

Any mapping program (other than one designed to output to a line printer) requires a graphic interface as well as a user interface in order to generate plotting instructions to be written to a plot descriptor file (PDF). Such an interface generally consists of calls to a set of system-supplied subroutines which, in turn, generate instructions defining the scaling of the plot, the colour of the output and the movement of the pen, etc. Such subroutines are generally assembled into a graphics library, of which there are several available: each university installation will have one if not more. As supplied, GIMMS includes calls to the libraries GINO-F, CALCOMP, ERCC and GERBER. In version 3 (V3) of GIMMS, the first to be mounted at NUMAC, the user needs to know which library to call. This is not the case in the second version to be mounted at NUMAC - development version 4 (DV4): in this, calls to any graphics library are transparent to the user. To the implementor, however, this may not be the case, for if one of these libraries is not available at his installation, a certain amount of re-programming is necessary. This was the case at NUMAC. Here, both the GINO-F and CALCOMP libraries are available but neither is officially supported (i.e. documentation is poor, 'bugs' exist within them and no effort is made to update the libraries). Thus GIMMS had to be modified to include calls to another graphics library.

Had GIMMS solely to have been used for cine film production, the choice of subroutine library would have been obvious. The

FR80 microfilm recorder only accepts PDFs generated by the Rutherford Laboratory's graphics package SMOG. Thus, ideally, GIMMS should be able to call the SMOG library in order to generate acceptable PDFs for the FR80. The possibility of mounting SMOG at NUMAC was investigated but, unlike most libraries which are simply variants of the CALCOMP package, SMOG was written specifically for the Rutherford Laboratory, and is installation-dependent and non-portable. The effort needed to mount SMOG at NUMAC would have been 'considerable' (Nelson, 1978, pers.comm.)<sup>1</sup> and there would be no more support for it than there is for GINO-F and the CALCOMP packages at present.

It was thus decided to modify GIMMS to include the graphics library IG (Integrated Graphics). This is the standard MIS graphics library, and has the advantage over and above the one remaining library at NUMAC (PLOTSYS) that it is geared to interactive work and thus is well suited to GIMMS. The two versions of GIMMS modified to run at NUMAC - V3 and DV4 - differed in the form of their graphics interface. In V3, the library subroutines are called directly from the program itself. Thus the implementor has to search through some 20,000 or more lines of Fortran source code in order to insert calls to IG alongside those to GINO-F etc. Implementation is not easy, and such a set-up is not totally transparent to the user (who has to specify which library is to be used). In DV4, which was implemented by the author in November 1980 and used to make the final films, GIMMS calls a standard set of subroutines. The

---

1. P. NELSON. Rutherford Laboratories.

implementor then has to write these subroutines, calling the chosen graphics library routines. Thus, although a two-stage process (GIMMS calling the graphics routines directly) has been transformed to a three-stage process (GIMMS calling a common set of subroutines which are supplied by the installation and which in turn contain calls to the installation's graphics library), the program is much easier to implement, and such details have become transparent to the user, if not to the implementor.

GIMMS itself is modular in structure. Entry into the program is via the main control module, in which certain system parameters are set (for instance whether the output is to go to the screen or to a PDF). From this, the user may enter modules for locational (topographic) data management, non-locational (thematic) data management, interactive map design or map production. Such a modular structure allows only parts of the program to be loaded if so wished - one NUMAC variant loads only those parts of GIMMS necessary for interactive design and map production, which allows the program to run in rather less memory than usual. It is usual to run the locational data management and map production modules in batch, with the remainder in terminal mode but this is not always so - by running (for instance) the locational data management module interactively, errors can be found in the linkages of segments to areas - a critical test.

The above constitutes a general description of the principal plotting package used in this research. Section 7.4 provides a

more detailed examination of its application to produce PDFs which were previewed at NUMAC to check for correctness, before being transferred to the Rutherford Laboratory for plotting. The following sections examine the hardware and the software available at the Rutherford Laboratory.

## 7.2 FACILITIES AT THE RUTHERFORD LABORATORY

Once generated and checked, the maps were transferred to the Rutherford Laboratory on nine-track IBM standard labelled tape for plotting. Hardware used at this stage is now examined in greater detail.

### 7.2.1 Hardware

At the time of this research, the Rutherford Laboratory's computing system was based on two IBM 360/195s: an IBM 3032 was also added later but this was not used by the author. Access to the facilities was via a workstation at Durham University - consisting of a 10 inch Tektronix CRT, a card reader and a line printer. These were adequate for the submission of jobs, the previewing of plots and the receipt of printed output. Jobs are submitted to the 360s (which at that time ran under the operating system IBM OS) via the file-handling system ELECTRIC: there were

at that stage no interactive computing facilities available. The 360s were used simply to read the PDFs from magnetic tape and convert the data thereon by program to the local FR80 format; details of this process are given in the next section. A combination of no interactive computing facilities and 12 tape drives ensured that the turnaround of such batch jobs was very good - no more than a few hours even for the longest production jobs.

The FR80 microfilm recorder itself has a CPU of 32K words of 18 bit memory, together with a one-quarter million word fixed head disk and three magnetic tape drives. Output is provided by a precision light source CRT and a choice of four different cameras is available (standard 16/35mm, precision 16mm, microfiche and hardcopy). The device is similar to, but more sophisticated than, that used by Meyer et al (1975) to map the US census data. It is also significantly more sophisticated than the microfilm plotter used by Jeffrey et al (1975) and gave better results than they can claim. It has been used by the author for a number of other mapping purposes (see for instance Adams et al, 1980).

The plots are displayed on a high resolution CRT which is optically flat and has a 3.5 inch plotting area. This screen is divided into a raster of 16,384 points in each direction; any one pixel (picture element) may be addressed. Plotting can be done in any of three modes: vector, point and character (character forms being stored in the CPU). Vector plotting (the only mode

used in this research) is exceptionally fast on the FR80 - optional (user selected) speeds are 1, 2, 4 or 8 milliseconds per full screen vector. The effect of changing the plotting speed is in fact to change the exposure of the film - the higher the speed the less the exposure. A default speed is set up for each camera type (4 milliseconds per full screen vector for the 16/35mm camera) which the author decided not to change - in tests, altering this either under- or over-exposed the film. Plotting is also very accurate: repeatability is equal to 0.25% of the full screen maximum or, within 0.15in of the centre of the film, 0.1%. (It must be stressed that these are the manufacturer's specifications, although tests carried out on the FR30 in October 1979 showed the Rutherford Laboratory's machine to deviate from these by less than the accuracy of the measuring instrument.) Table 2 of Adams et al (1980) compares the FR80 with other contemporary microfilm plotters - it can be seen to compare very favourably.

Colour output may be produced on the FR80 using the standard 16/35mm camera. This camera incorporates a filter system working on an additive basis. There are three filters - cyan, magenta and yellow. By combining these the three primary colours can be produced - cyan and yellow for green, magenta and yellow for red and cyan and magenta for blue. In addition to the three primary colours, the light intensity on the FR80 may be set at any one of 256 levels. Thus by combining different filters and intensity levels, together with line overstriking, it is possible to

produce a wide range of different colours. However, a problem associated with the use of colour is the degradation of resolution. In black and white, two points are discernible as separate entities at a distance of 10 raster units apart. In blue, the corresponding distance is 12 raster units, and from here, it increases through the spectrum to a distance of 25 raster units for red. (These figures depend also on the type of film used, in this case Kodak Ektachrome EF.) Thus if producing animated films in colour, a certain loss of clarity and sharpness must be expected, as compared with those in monochrome.

### 7.2.2 Software

In order to use the FR80, PDFs were dispatched from NUMAC written on magnetic tape. Nine-track IBM standard labelled tapes were used, recorded at 1600 bpi. The transfer of very large PDFs was a major problem; since tapes recorded at 6250 bpi hold approximately four times as much information as the lower density versions, their use for large files is much to be preferred but their creation at NUMAC was impossible at that time. Before the use of the repeat facility (see section 7.3.3) this was indeed a major constraint - the length of early films was in fact limited to the number of PDFs which could be held on one tape recorded at 1600 bpi. Because of the repeat facility, however, it was possible to fit the PDFs for the final films onto one tape only.

PDFs are simply files of binary information which are interpreted by appropriate software to drive output devices, in this case the FR80. PDFs differ in structure depending on the graphics library which produced them (for instance an IG-produced PDF has records of only 256 characters in length, whilst a PLOTSYS one is of up to 32,767 characters). Thus it was necessary to 'interpret' the PDFs from an IG type to one as produced by SMOG and therefore acceptable to the FR80. In order to do this a small interpreting program was written in Assembler and Fortran to run on the Rutherford Laboratory's 360/195 by Mr N Hall, and implemented by the author.

An IG PDF contains only four different types of record: a PBGN record which marks the start of the file and holds the scaling information, a PEND record marking the end of the file, a PPEN record indicating the colour of the output, and a POOD record which simply represents one or more vectors (dependent on length) in the form of positions for 'pen-up' and 'pen-down'. In order to interpret this file, the records were read from magnetic tape one by one and, dependent on the type of record, certain SMOG routines were called to output to a separate PDF the information contained on the tape, this time in SMOG format. On encountering a PBGN record, the program would call SMOG routines to initialise the camera type, set up scaling parameters and also the number of repeats needed (see following section). The device type, plot size and number of repeats were all supplied at run time. PPEN records activated the SMOG subroutines for filter selection

within the chosen camera, whilst PEND records set the number of repeats to zero (see following section), advanced the film and (if followed by a tape marker on the input tape, which indicated the end of the PDF) output the buffers to the SMOG PDF, thus closing it correctly. POOD records simply invoked the SMOG subroutines for moving the pen (or light source in this case) from point A to point B.

The program was compiled and stored on disk at the Rutherford Laboratory. To generate a PDF of commands from an incoming tape, a job was submitted via ELECTRIC and run on the IBM 360/195. This mounted the tape, ran the compiled program to decode the file, and wrote the SMOG PDF to an output tape which was then transferred to the FR80 for plotting off-line. Some time later (depending on the pressure of work for the FR80, but approximately three to four days on average), the processed film would be returned to the author at Durham, by post. The entire process is illustrated in figure 7.1.

Foley (1978) has argued for a world-wide common graphics package, akin to ANSI Fortran. If this were the case, no modification to GIMMS would be needed, neither would the interpretation of PDFs be necessary at the Rutherford Laboratory. All PDFs could be produced by a standard graphics library and run to any output device. Unfortunately, whilst an excellent idea, the great variety of existing hardware, operating systems and plotting packages mitigates against it, and such conversion programs will probably be necessary for the foreseeable future.

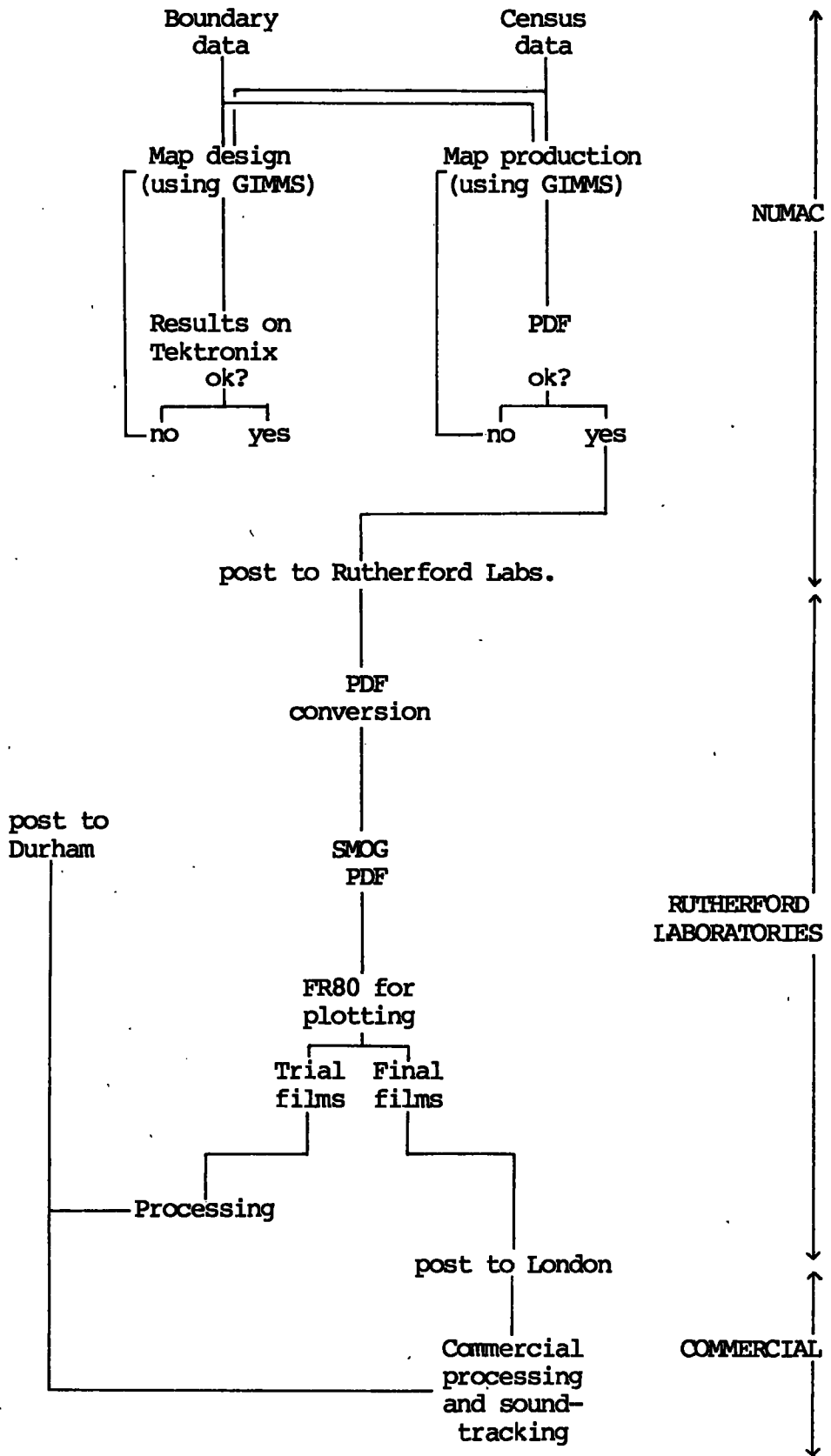

Figure 7.1: The film production process.

### 7.3 FILM TESTS

To summarise to this stage in the film production then, the topographic and thematic data had been assembled and checked (chapters 4 and 5). The mapping program GIMMS had been implemented at NUMAC and a provisional layout of the maps themselves had been determined (chapter 6). The Rutherford Laboratory's end of the process had also been established and tested, and was ready for film production. What was required next was a series of tests to ascertain precisely the likely final form of the film, not in terms of content (which had already been determined, see chapter 6), but in terms of design. To this end, a series of trial films was generated to test aspects of colour, layout, timing etc. Such tests are now examined further.

In order to conduct any trials, the topographic data had to be re-created in a form from which it was possible to map. For use in GIMMS, the disaggregated segments (see section 5.5) had to be built to complete area descriptions, or polygons. To do this, the segments were reformatted and input through the topographic data manipulation module in GIMMS. This is a two stage process: first the actual co-ordinates are read into a GIMMS segment data bank using the \*BASEFILE or \*FILEIN commands (V3 and DV4 respectively). From this data bank, complete areal descriptions are then built using the \*POLYGON command. GIMMS has a facility to allow for the direct input of complete closed areas

(\*CREATEFILE). However, this is not generally used as, apart from being more difficult to digitise closed areas accurately, the use of segments in GIMMS for which both left- and right-hand feature codes are stored eliminates the problem of 'backlash'. On certain plotters, especially drum plotters, there is a certain amount of slackness in the driving motors for X and Y movements. Thus, a line drawn in one direction (from A to B) cannot be accurately repeated if drawn from B to A, particularly if it is on the diagonal between the axes. Common boundaries drawn twice - even if digitised in exact coincidence as separate polygons - appear as double lines. On the FR80, such common boundaries drawn twice appear considerably brighter due to increased exposure. In GIMMS, the left- and right-hand 'feature codes' or attributes are stored in the polygon file - but only if it has been built from segments. When a particular polygon is being plotted, then, it is possible to ascertain which parts of the boundary have already been plotted as part of another polygon, and therefore should not be repeated. Segments rather than complete polygons then were input to GIMMS to be built to closed areas. The topographic data as supplied had formerly been topologically checked once to ensure all areas did in fact close (Baxter, 1976), so no problems were encountered in building the polygons.

Once the boundaries were input to GIMMS, the creation of test films could begin. Several short test films were created, each testing many features. These features were common to both parts

of the final film - the density section (see section 6.2.1) and the chi section, (section 6.2.2), and it was not necessary to run two separate sets of trial films. Common features are now examined under the headings of general layout, colour and timing. Throughout this section, certain measurements are given. These refer to the dimensions of the map and contents as originally plotted on paper hard copy: some overall scaling is necessary when plotting on film.

### 7.3.1 General layout

A general layout for each map was in fact established before any filming took place at all, using hard-copy pen plots (see section 6.3.1). Basically this was a map of Britain, with the Shetland Islands inset within the top left-hand corner, and space beneath these for the title and the key. Since the question of date is of crucial importance to the film this was considered first.

The two conventional methods of indicating the time period to which the data on display refer are the use of a clock or of an extending bar. In the use of a clock, the total time period is represented by a circle around which moves either a pointer or a line parallel to the circumference. In the use of a bar, a line simply grows as time increases. Moellering tested both types in his work on cartographic animated filming, and argued that use of

the bar is preferable (see section 2.4.1). Both types were, however, rejected for these films for two reasons: first, it would be reasonably difficult to draw either a bar or a clock annotated with dates using GIMMS, and secondly, both methods give a better impression of relative rather than of absolute time. Thus it requires some thought to translate into an absolute date how far the clock hands have moved round, or the bar has grown from its origin. In an animated film, "calculation" of the date by the viewer detracts from viewing change on the maps: there is little time to do both. A solution was found in writing the date as the title (e.g. '1901' in the density film, and '1901-03' in the chi film). Since numbers cannot be made to dissolve into each other without distorting themselves gradually over a series of frames, a flick occurred every time the date changed. But, against this one disadvantage, is the advantage that a glance revealed the exact date in question: simplicity and clarity (as argued in chapter 6) are essential in animated filming.

For simplicity, it was also decided not to include a title (other than the date) in each map. The inclusion of a title (to the effect 'density of the population') would have used up valuable space, and the viewer was expected to remember the topic. Some help in this was, however, given in the form of the legend. It was decided to include a legend because, whilst it is easy to remember a general topic, it is more difficult to remember exactly what the symbolism represents. Simple legends of two classes for the density section, and three for the chi

section were therefore included, using the appropriate GIMMS options. The legend was placed below the date which was in turn below the inset of the Shetlands, this being the only space available.

GIMMS includes some 24 different alphabets (including the Hershey fonts). Several tests were made to determine the font and the size of lettering to be used. The results of these tests accorded with the aims of clarity and simplicity - a triplex serif font was eventually chosen. This has very open letters, and may be read very easily; this decision was influenced by the problems of blocking up of certain characters in other fonts which had occurred in the author's work on topographic mapping on COM (Adams et al, 1980). Amongst the 24 fonts in GIMMS is one representing the Greek alphabet. Thus it was possible to use the Greek letter  $\chi$  rather than spelling out 'chi' every time, saving space. Furthermore, it is possible to sub- and super-script letters, allowing ' $\chi^2$ ' to be plotted correctly - and thus easier to read instantly and aesthetically pleasing.

The definition of an appropriate size of lettering, both for the date and legend, was a difficult task. Whilst the requirement of simplicity had been met by choosing an open alphabet, tests showed that in order to achieve the aims of clarity and legibility, lettering sizes had to be greater than that used in static mapping. Figure 7.2 represents example

frames (1) from the final films: in these 'static excerpts' the lettering appears overly large, and the maps unbalanced. The size of the legend lettering, especially for the middle class in the frame from the chi section, was constrained by a lack of space, and whilst readily visible on this map, in the film it could not have been any smaller without becoming illegible.

Examination of figure 7.2 shows all district boundaries other than the coastal ones to have been omitted from the map. This was done deliberately: a white line as produced by the FR80 is brighter than any other colour. In tests of maps which included internal boundaries, the maps appeared confused. The eye was drawn to the boundaries rather than to the shading and, in some areas (especially London), it was not possible to see the shading at all, it having been obscured by the boundaries. As has already been pointed out, on static maps the reader has time to establish the figure and the ground (see section 6.3) but in animated filming, an instantaneous impression has to be gained. If the boundaries are included, the outlines become 'figure' and the symbolism 'ground' - clearly not the desired result! Furthermore, boundaries are not necessary in order to obtain an overall picture of change, though some boundaries are undoubtedly helpful to the viewer in providing a clue to the identity of

---

1. Since these are hard copy pen plots, they are shown with black lines and coloured symbolism on a white background. In the COM output for the final film, the background itself is black and the black lines, white (see section 7.3.2). The coloured symbolism and map contents, however, are identical to these plots.

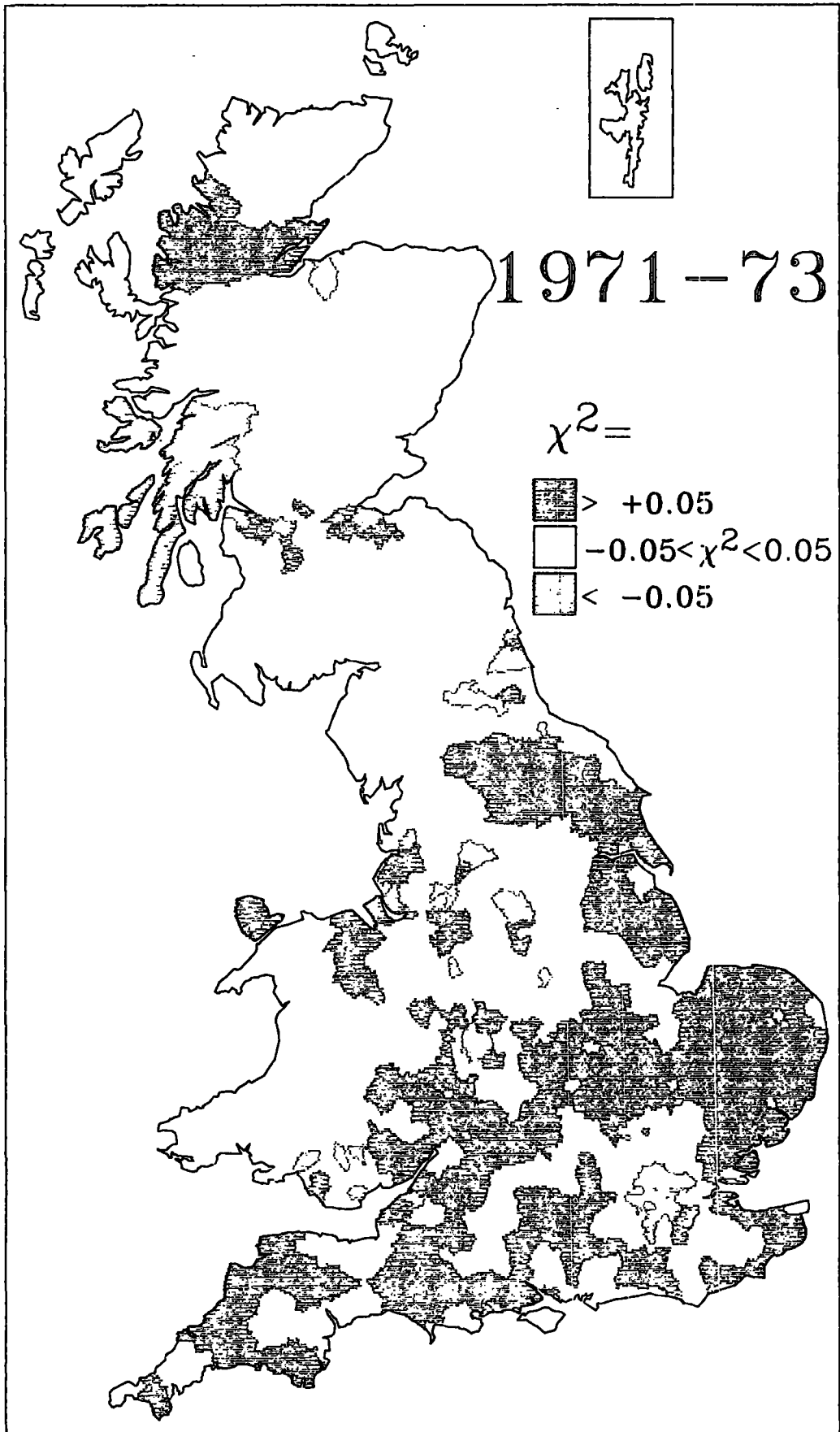

Figure 7.2.1

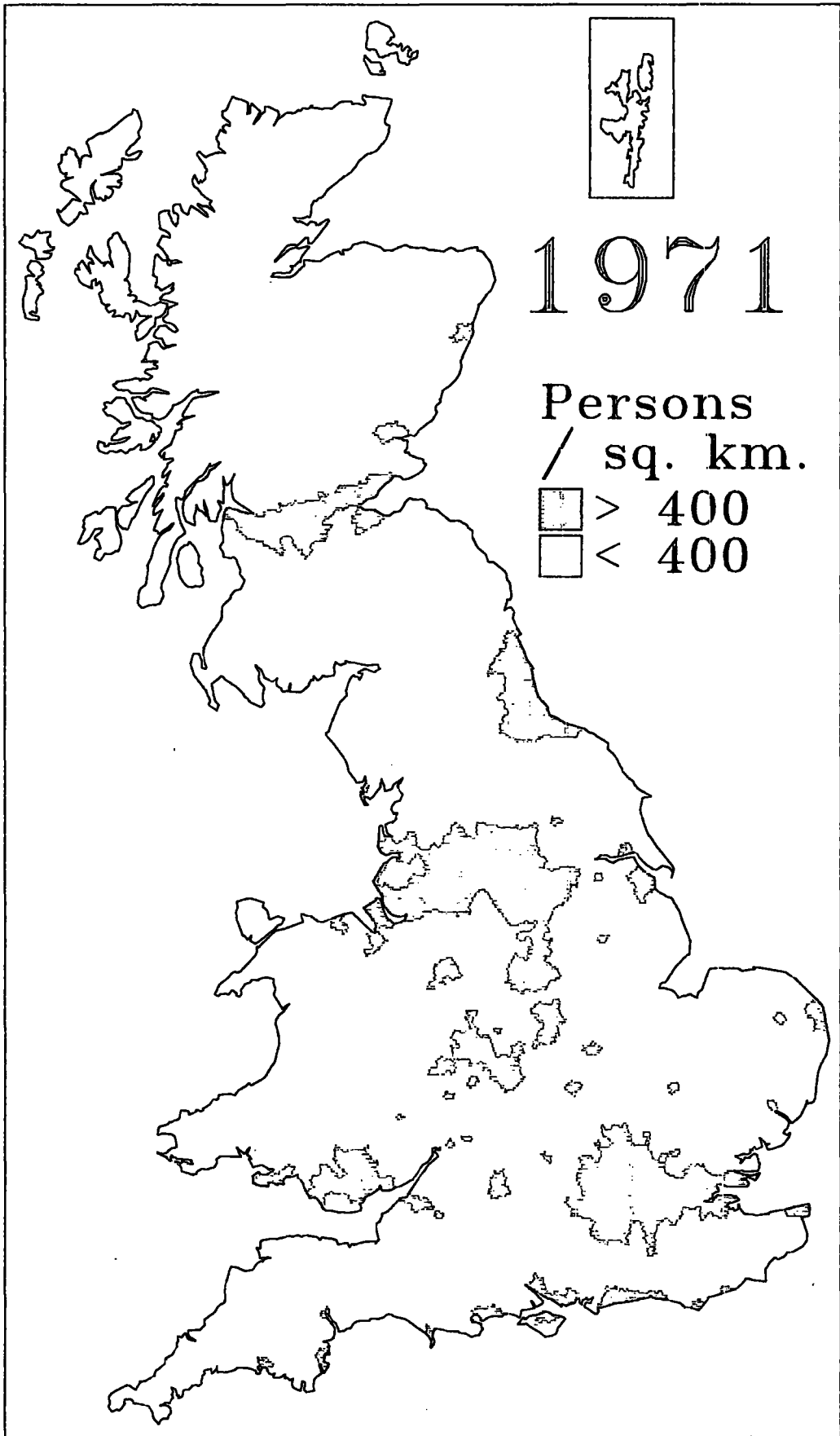

Figure 7.2.2

areas since some have distinctive shapes.

Figure 7.2 then shows the chosen map layout as established by film trials. These proved the titles and legends to be clear and legible and, by the exclusion of boundaries, the eye to be drawn to the symbolism on the map. The form of this symbolism is now examined.

### 7.3.2 Symbolism

Any material originating from the FR80 consists of white or coloured detail against a black background. This is because the film is actually a 'negative' - white or coloured lines represent parts of the film exposed to lines drawn on the screen of the FR80 by the precision light source. The film could be developed to a positive but, if colour is being used, this introduces considerable complications to the process. It was decided to retain a black background to the maps - as Dutton did with material from an FR80 for his work on cartographic animation (see section 2.4.2).

Preliminary tests in black and white showed best results to be achieved with the use of solid blocks of symbolism. Several patterns - dots, variable sized grids, diagonal hachures etc. - were used in attempts to achieve tonal variations (and therefore more than one type of shading) but, at the small scale of filming and against a dark background, there was little if no distinction

between classes. Without the use of solid shading, the darker background became 'figure' and the lighter shading patterns 'ground' - obviously not the desired effect!

This then led to the use of colour in films. In practice, it would have been possible to make the density section of the film in black and white - it only has two classes of density i.e. above and below 4 persons / ha. However, the chi section has three classes which then necessitated the use of colour. As with black and white shading, colour was found to be most effective in solid blocks. GIMMS itself could output material in any colour if the graphic interface permitted it. Unfortunately, the IG system is limited to the use of two colours - red and blue - plus black. IG plotfiles are set up such that the black parts of the image are written first, followed by a pen change record to red, then the red sections of the image. This is followed by a blue pen record and the blue sections of the image. Such a structure is in fact ideal for use at the Rutherford Laboratory since a filter is inserted in the camera in the FR80 to ensure variable coloured output: use of these filters was activated by the interpreting program on reading a PPEN record in the PDF. Being mechanical, filter changes take very much longer than drawing vectors. Hence an IG PDF generates the minimum number of filter changes, doing all the components of a particular colour before changing the filter and proceeding to the next colour. This contrasts with a PLOTSYS PDF where records are written as generated (rather than being stored and output as the final stage

of the program) and therefore pen changes (which would equal filter changes on the FR80) are numerous. The choice of graphics library thus ensured a major saving on the plotter.

Tests showed the use of blue and red as solid shading patterns on the FR80 to be most satisfactory. Experiments with other colours showed, for instance, green to be very 'recessive' and difficult to compare with red and blue. The FR80 itself is of course not limited to two colours (see section 7.2.1) - variable levels of light intensity and filter changes ensure any colour can be produced. But in order to produce anything other than simple primary colours, line overstriking is needed - which is expensive in FR80 resources. Moreover, it is difficult to include information on intensity levels in a PDF for interpretation at the Rutherford Laboratory. The two primary colours red and blue were chosen then for the shading patterns. Tests showed a combination of white outlines and lettering, red shading for the density section, and on the chi section red shading for decline and blue for increase (see section 6.2.2) to give the best results.

A remaining problem was how to create such solid blocks of shading within GIMMS. That package creates maps primarily by plotting and shading each area in turn: the whole process is based on area filling with vectors. First tests used this method primarily with a very small grid pattern of shading; on plotting on the FR80 this reduced to a solid block. Results were satisfactory. However, there is a second method of shading

polygons within GIMMS, designed originally to cope with the problems of unsophisticated pen plotters. If plotting in biro, the flow of ink to the 'nib' is activated by contact with the paper. A small portion at the beginning of any line is lighter than the remainder of the line due to the time taken to achieve an even flow of ink. Conversely, if plotting with liquid ink, the reverse effect occurs. The speed of plotting is generally faster than that of the supply of ink to the 'nib'. Hence the first part of the line - in which the pen is moving very slowly but accelerating - is darker than that following. If shading an area, then, the boundaries (which mark the start of the shading lines) are lighter in biro plotting, and darker in ink.

A GIMMS command (JOINSCAN) exists to minimise this problem. The start and end points of the shading lines for every area are calculated and stored. Before plotting on the screen or writing records to a PDF, the lines are sorted, and those from adjacent zones whose ends are coincident are joined into one vector. Thus the effect of raising and lowering the pen which produces darker or lighter zones at boundaries between areas of the same class is removed, except at the outermost edges of these 'mega-parcels'. Whilst the CPU time for map production is generally increased (due to the need to sort shading lines) a side effect of such a modification is a reduction in plotting time on mechanical plotters, and also in the size of plotfile produced. This method is most effectively used with horizontal line shading, which needs to be closer together than grid shading in order to block

up on reduction (in trials, 0.1 mm separation on the original for horizontal shading, as opposed to 0.15 mm for grid shading). Although the shading lines are closer together, plotting time is decreased due to a reduction in the number of 'pen-ups' and 'pen-downs' necessary. On the FR80 (as on any CRT), a further reduction occurs in that the time taken to draw a vector is not proportional to its length - actual positioning of the starting point of the line takes longer than plotting. Despite decreasing the distance between shading lines (see above) - which to a certain extent counteracts a reduction achieved through the removal of the vertical shading lines - reduction in plotting time is achieved through an overall increase in mean vector length. The reduction in the number of records written to the PDF may be very significant. A POOD record in the PDF simply records the positions for pen-up and pen-down. Thus, the largest number of records are produced by dot shading and conversely, the longer the vectors, the fewer the number of records (fewer pen-ups and -downs have to be recorded). Hence the time taken to read and interpret the PDF's at the Rutherford Laboratory was diminished by the use of JOINSCAN, a factor of some importance when CPU time was being paid for in real money! Table 7.1 shows the results of experiments conducted with the use or omission of JOINSCAN. An interesting feature of this table is the reduction of CPU time required but such a reduction is not guaranteed for every map which uses this command; the sorting of the records usually increases the time.

Table 7.1: Results of film trials.

	FILM NUMBER			
	1	2	3	4
Joinscan	no	no	yes	yes
<u>MIS</u>				
CPU time	44.73	48.54	43.79	46.31
<u>RUTHERFORD</u>				
Tape IOs	203	244	148	155
Job CPU	4	4	3	3
<u>FR80</u>				
No. plot records	133	160	97	102
CPU time	1.883	2.279	1.398	1.503
Plotting time (min.sec)	13.44	17.15	8.47	9.16

Each film had five frames; each frame was repeated 16 times. The contents of films 1 & 3, and of films 2 & 4 were identical.

Source: Calculated from basic data.

In summary, then, solid red and blue symbolism was chosen, created by plotting horizontal shading lines some 0.1 mm apart on the original hard-copy maps. Not only did the use of JOINSCAN slightly decrease the NUMAC map compilation time, but it led to a reduction in both compilation and plotting time at the Rutherford Laboratory.

### 7.3.3 Timing of films

With the final design of the maps complete, all that remained was to plan the timing of the film. The aim is to determine the amount of time a map should be on the screen before moving to the next map, the difference between the two maps representing change. The time a map is on the screen is determined by the number of times the frame is repeated on film, e.g. at sound film speed of 24 frames / second, 12 repeats of a map gives a projection time of 0.5 seconds. The phenomenon of persistence of vision (see section 2.1) dictates that if change is to be absorbed into a smooth motion, each frame should not be repeated more than three times. However, there is a crucial difference between conventional animated filming and the animated filming under study here. In the former, each frame is only fractionally different from its predecessor; in the latter, the difference between the two frames can be substantial (a district may be blank in one and shaded in the next). There is no question (in

this film) of change being fractional and motion smooth - more abrupt change occurred and a jerky motion resulted. (In practice, such abrupt changes were found to be beneficial - the eye was drawn to the changing area.) It must be stressed, however, that smooth translations could be achieved if the data were to be presented differently, for instance by use of continuous shading (see section 6.2.1).

Thus if very smooth motion is not, in this case, the ultimate aim, and there is to be no substantial persistence of vision, the limit of three repeats of each frame does not apply. The aim instead is to determine the number of repeats of each frame which would enable the viewer to interpret the situation before moving to the next map - difference between the two maps suggesting change. There are no published guidelines to suggest film timing - several tests were carried out to ascertain what it should be. Timing of films depends of course on projection speed - 16 frames / second for silent speed and 24 frames / second for sound speed. From a large number of experiments, two seconds projection per map was found to allow the reader time to assimilate the image before moving to the next one. Since the films were ultimately to be soundtracked, this meant a repeat of 48 frames per map. If no soundtrack is required, a film may be projected at three seconds instead of two seconds per map, thus allowing extra time for interpretation if necessary.

A SMOG subroutine for the generation of such identical frames already exists: it would have been impossible to copy every map

48 times to a magnetic tape at NUMAC - the density section alone would have spread over three tape reels. The number of repeats was supplied to the interpreting program at run-time (see section 7.2.2), and written to the head of the SMOG PDF to be interpreted in turn by the FR80 - the image is then drawn and exposed to the film over the desired number of frames (in this case, 48). This method of 'stretching' is perhaps the most convenient; optical methods such as used by Massey and Dutton (see chapter 3) require operator intervention, with a possibility of human error. Moreover, accurate registration can be difficult. A disadvantage of 'stretching' the film on the FR80, however, is that it increases substantially the plotting time. This in turn can be expensive; plotting of the original frames for the film enclosed with this thesis cost in the order of £900. Other film producers should attach no significance to this figure however, as plotting costs vary widely, depending on the type of plotter, ownership and method of usage.

This then completes the design of the film. In the absence of relevant literature and well-developed computer-animation theory, this stage was very much one of trial and error, from the implementation of GIMMS and an interpreting program at the Rutherford Laboratory, to the design of each map itself. Such an operational procedure led to many difficulties and problems, ranging from the trivial (the extremely large size of PDFs in terms of disk space) through the irritating (the poor or non-existent documentation for both GIMMS and the SMOG system) to

the extreme (the general problems of 'distributed' computing - input at one place and output some 400 km away, including delay and total loss in transit of both magnetic tapes and films). Eventually, all such problems were overcome and the films created. The following section examines the production of the final output.

#### 7.4 FILM PRODUCTION

The finished density section of the film consists of a series of 40 maps, one for each alternate year between 1901 and 1979. The chi section has only 39 maps, one for each two yearly interval throughout the same time period. Because the production of such a large number of maps in one GIMMS run is not feasible, each section was split into four runs of ten maps each (9 maps in the final run of the chi section). Thus four PDFs for each section were produced, and joined on being copied to magnetic tape. The one amalgamated PDF for each section was then transferred to the Rutherford Laboratory on tape for plotting.

Figure 7.3 represents a copy of the file of GIMMS commands used to produce each PDF for the density maps. This file runs DV4 of GIMMS - the V3 files were slightly different - and appendix D outlines the purpose of each command.

The ease of use of GIMMS, and its tremendous flexibility should be apparent from figure 7.3 and appendix D. Such

Figure 7.3: Example GIMMS run.

---

```
*PLOTARM PLOTTER
*SYSPARM NOLIST
*TEXTARM FONT=16
*PLOTPROG
*GIMMSFILE 11 F=0.005 *
*GIMMSFILE 10 F=0.005 *
*DATAFILE INPUT 11
$continue with data0121 return
*LEVELS 2
*INTERVALS VARIABLE=2 USER=0.0 4.0 500.0 / V=3 SAME /
V=4 SAME / V=5 SAME / V=6 SAME / V=7 SAME / V=8 SAME /
V=9 SAME / V=10 SAME / V=11 SAME *
*JOINSCAN 7
*LEGEND POSITION = 19.2 31.25
BOXSHIFT = 0.00 1.70
BOXSIZE = 1.50 1.50
NOVALUES
*OUTLINE NONE
*NEWMAP 30 52 F *
*SYSPARM REWIND 7 *
*SCISSOR 21.0 45.0 24.0 51.5 F *
*ORIGIN 21.0 45.0 4100 11000 *
*DRAWMAP 11 *
*SCISSOR OFF *
*ORIGIN MAP=620,0
*DRAWMAP 10 OUTLINES=OUT *
*TEXT 23.4 40.87 2.70
CENTRE CENTVAL=-1
TEXT='1901'
*TEXT 21.24 33.15 1.20
'^> 400' /
21.24 31.45 1.20
'^< 400' /
19.2 37.0 1.20
^P@LERSONS
/ SQ. KM.' *
*MAP 2 AREA *
*END
*STOP
```

flexibility however is achieved to some extent at the expense of computer time - a purpose written program would run quicker than such a general program. The production runs took a total of 339.9 seconds of CPU time on the NUMAC IBM 370. Such a time at first seems very large, but in fact equals only 8.5 seconds / map. Certain commands need only be loaded once per run - generating all the plots in one run then would have saved loading these three extra times, and over 20 seconds of CPU time. The time taken then is not excessive, but is essentially in the ratio of 4.5:1 when compared with the viewing time after the generation of repeats.

With suitable modifications to the \*LEVELS, \*INTERVALS, \*SYMBOLISM and \*TEXT commands, the file as listed in figure 7.3 was also used to generate the chi maps. Production runs for these maps used 336.5 seconds of CPU time, but this is only for 39 maps - generation of each map took 8.6 seconds. (Again the time is increased by splitting the run to four jobs.) This small increase is due to the larger amount of shading on the chi maps, particularly those of 1961 onwards.

Interpreting the PDFs on the Rutherford Laboratory's IBM 360 was a comparatively speedy process - some 13 seconds for the density run and 14 seconds for the chi run (although the IBM 360/195 under OS is approximately four times as fast as the 370/168 running under MTS). However, the plotting of the films on the FR80 plotter took much longer - 3 hours, 53 minutes and 15 seconds for the chi maps, and 3 hours, 55 minutes and 24 seconds

for the density maps (plotting time for the chi maps is less because there were only 39 original maps). The length of the plotting time on the FR80 was in fact a major source of delay - very long jobs take a low priority in the plotting queue and, on occasion, such delays amounted to over a week. (Such a time is obviously a function of the amount of work for the FR80, and so varied considerably: turnaround was on average some three to four days.)

Header and tail frames were also created using GIMMS: PDFs were generated using the same alphabets as were used in the films themselves, and transferred for plotting at the Rutherford Laboratory. Again they were run to 16 mm colour film although the original data were in black and white - it was thought preferable not to change film types at this stage.

Early test films were developed at the Rutherford Laboratory, but the processing facilities there are very limited, and cannot hold a film of more than 2,000 frames. Output developed there, whilst good enough for test films, is generally of relatively low quality and varies in focus throughout. Hence the undeveloped final films were sent to a commercial film processing laboratory in London, where they were also eventually soundtracked. The FR80 films were developed to a master copy, from which prints were taken. To avoid damage to the master film, prints were used to work out the final order of screening, and the soundtrack. In determining the final order of screening, it was found advantageous to repeat both the density section and the chi

section. Viewing each part for a second time aids the process of visual interpretation; it also allows (via the soundtrack), on the first viewing, for an explanation of the basic principles involved and, on the second, for identification of specific areas of population change in Britain.

This completes the section on film production; the reader will find the final film (which consists of both the density and the chi sections joined to one) enclosed with this thesis. The final chapter of the thesis now examines briefly the results.

## 8 AN ANALYSIS OF THE RESULTS

The aim of the research (as noted on page 5) was simply to investigate the use of the animated film in cartography via the creation of one such film: in this chapter, the conclusion, the results of such an exercise are assessed. It is convenient to consider the relative success of the film from two aspects: first as a means for portraying change in the population and secondly, and more generally, as a cartographic technique. These conclusions are brief: in the absence of reliable statistical analyses of perception studies of the animated film, there is no right or wrong answer to this research, and, for the most part, it is left to the viewer to judge the success of the film. The maxim 'beauty is in the eye of the beholder' applies here: the viewer's expectations, skills as a map reader and prior knowledge of British population change will all affect the overall result, thus the conclusions presented here are personal to this author.

### 8.1 THE ANIMATED FILM IN POPULATION MAPPING

The success of the film as a method of portrayal of population change may be considered in three sections. First, features common to both sections of the film (the density and the chi sections) are examined - chiefly these are the data, and, very briefly, the use of choropleth mapping. Secondly, the density

section itself is considered, and thirdly, the chi section.

### 8.1.1 Overall characteristics

The success of the film as a method of portraying population data depends in part upon the data itself, and also upon the method of presentation.

As shown in chapter 5, the historical population data can never be proved right or wrong - the only way to do this would be to reaggregate the enumerators handbooks of each census year to the new districts. This is clearly impossible, if only for reasons of confidentiality: even OPCS had to use a proportional method in their aggregation of population data prior to 1961 to new counties. The derived data set at least was controlled to the OPCS county level population (see chapter 5) and therefore massive errors should not exist within it. But the accuracy of the data set interpolated from this derived data is more questionable. Definite limitations may be associated with the interpolation method as was demonstrated in figure 5.5 (page 190).

In an attempt to measure the overall accuracy of the interpolated data set, the total population for Great Britain at each interpolated year was compared against the Registrar General's mid-year estimates for the same year. Table 8.1 shows the results of this comparison. Certain points may be noted.

Table 8.1: Comparison of mid-year estimates and the interpolated data set.

Date	Mid-year estimate	Interp. data set	Diff.	Date	Mid-year estimate	Interp. data set	Diff.
1901	37091	36993	98	1953	49209	49283	-74
1903	37829	37858	-29	1955	49552	49743	-191
1905	38583	38697	-114	1957	50032	50234	-202
1907	39349	39488	-139	1959	50549	50748	-199
1909	40133	40207	-74	1961	51380	51280	-100
1911	40887	40828	59	1963	52190	51827	363
1913	41302	41339	-37	1965	52892	52379	513
1915	42062	41759	303	1967	53487	52928	559
1917	42341	42117	224	1969	54022	53462	560
1919	42182	42443	-261	1971	54032	53975	57
1921	42814	42767	47				
1923	43337	43119	218				
1925	43802	43497	305				
1927	44138	43901	237				
1929	44433	44333	100				
1931	44831	44793	38				
1933	45262	45276	-14				
1935	45598	45763	-165				
1937	46008	46239	-231				
1939	46467	46685	-218				
1941	46908	47086	-178				
1943	47448	47453	-5				
1945	47823	47795	28				
1947	48170	48136	34				
1949	48941	48482	459				
1951	48918	48852	66				

Change by decade (from mid-year estimates)	
1901 - 1911	3796
1911 - 1921	1927
1921 - 1931	2017
1931 - 1941	2077
1941 - 1951	2010
1951 - 1961	2462
1961 - 1971	2652

All figures in thousands.

Source: See Appendix C.

First the mid-year estimates themselves may vary in accuracy throughout time as a result of variations in the methodology used to produce them (see section 4.2); it is thus not an ideal data set to use as a control. Some indication of the accuracy of the mid-year estimates is given by the difference in totals for census years. For these years, the population totals of the interpolated data set exactly matched the population totals supplied by OPCS in their 1974 census volumes. These years are not interpolated results but actual values from which the intervening interpolations were performed. Yet, whilst the differences in totals for these years are some of the smallest, they give some indication of the overall difference between the mid-year estimates and the census values.

Secondly, differences between the mid-year estimates and the interpolated data set show an irregular but cyclical pattern (see figure 8.1). This is probably a function of the interpolation algorithm.

Thirdly, the differences between the two data sets are not great - except during the 1960s, they are always less than 1%. That they are greater during the 1960s is a measure of the weakness of the interpolation algorithm in interpolating through periods of rapid population increase - as table 8.1 shows, population increase during this decade was the highest this century.

Overall then, the differences between the two data sets are not important, certainly at the national level, and especially if

**Figure 8.1: Difference between the Mid-Year Estimates & the Interpolated Data Set.**

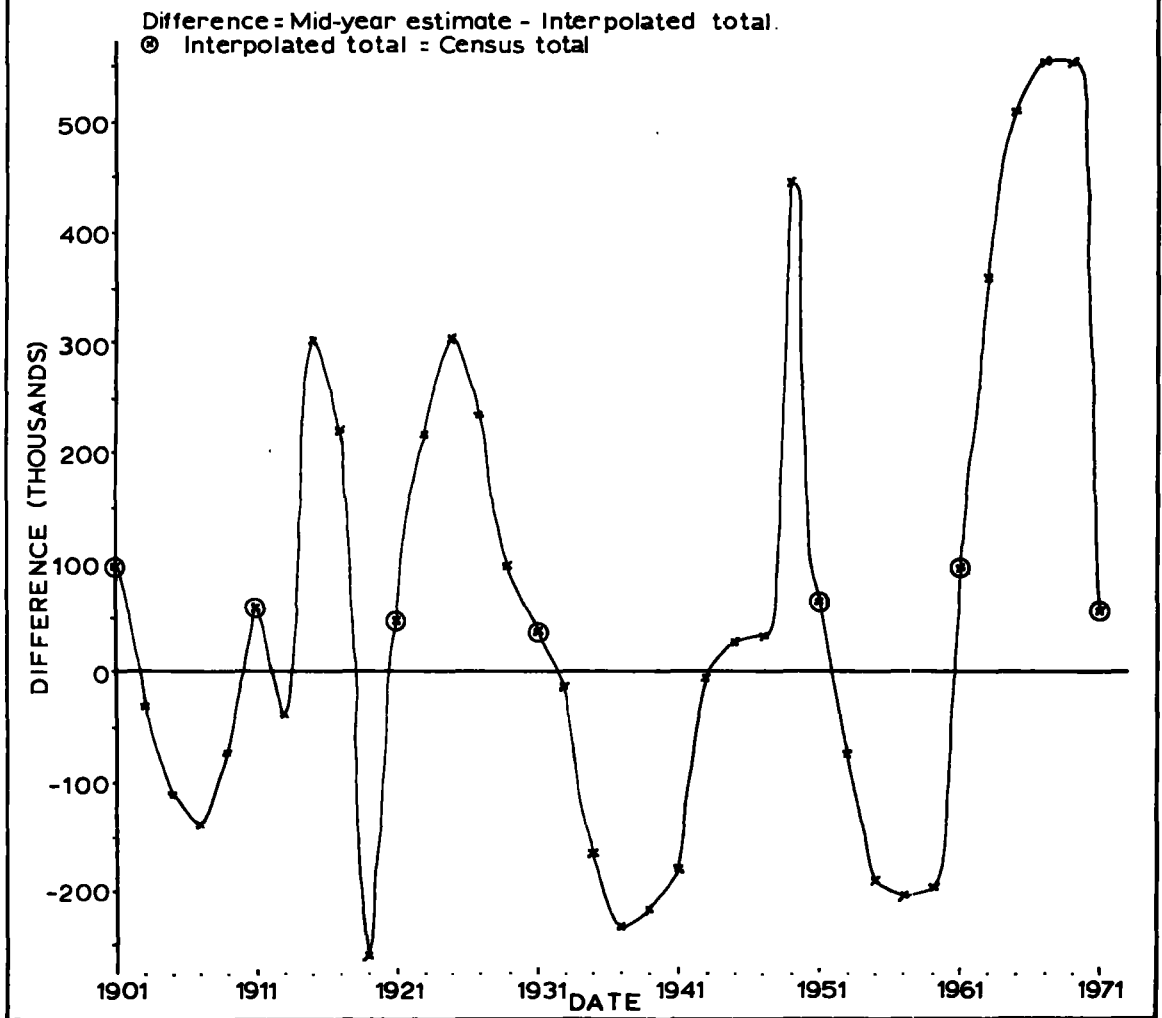

the interpolated data set is viewed as nothing more than a means for testing a cartographic technique. It is conceivable that other researchers will use the derived data set - it is for instance presented as an appendix to Rhind (1982) - but it is unlikely anyone will use the interpolated data.

The success of the film also depends on the method used to portray the data. Choropleth mapping as used here was unused before this research. In some respects, more idea of change is given by '3-D mapping', but values can be very difficult to assess from this, and there are also problems of change in 'hidden' areas; moreover, it is not known how efficient map readers are in perceiving and understanding these displays when used in animated films. There is, in this film, no substantial persistence of vision due to the size of areas, and because of the measures used to present change in the population. But precisely because there is no persistence of vision, areas of change show up - they flick on and (less often) off, drawing the eye towards them.

### 8.1.2 The density section

In this method, the selection of a threshold value is very subjective. Furthermore, it assumes that an 'urban area' may be defined by the same criterion through time - i.e., a specified population density, in this case, a value of 4 persons / ha,

being chosen. But there is some evidence that this is not so; the phenomenon of suburbanisation suggests the critical population density is dropping through time. (In some respects this is simply an increasing concept of spaciousness and is reflected by a lowering of the criterion for overcrowding (number of persons / room) in the census.) Hopefully, a value of 4 persons / ha is low enough to cope with this problem: if anything it would be too low at the start of the century, but there is little evidence of this in the density film.

As suggested by the soundtrack to the film then, some patterns of population change can be deduced from the film. But these are not very detailed due to the overall insensitivity of density as a measure of population change, especially when used in this (very simplistic) manner; this in turn is due to hardware (but not software) constraints.

### 8.1.3 The chi section

In contrast to the density measure, the signed chi-square statistic is much more sensitive and gives greater detail, although some of the patterns can be difficult to interpret. Constant loss in urban centres throughout the 20th century is apparent: a minor criticism of this film which has been made concerns the relative use of red and blue for loss and gain respectively. Such a selection is purely subjective, and may in

fact represent the reverse of many cartographers conceptions. But red is a dominant colour, and blue recessive (Audley et al, 1981). The red areas are also much smaller in extent. If the colours were reversed then red areas of increase would visually dominate over smaller blue areas of decrease; the synoptic view given by red as decrease and blue as increase was felt to be preferable.

As methods of presenting change in the population then, the films are reasonably successful. The use of a density measure is somewhat insensitive, whilst the chi measure gives patterns which, although they conform to, and illustrate in some detail, the generally accepted pattern of population change in Great Britain (inner urban decrease and suburban expansion), are sometimes difficult to interpret at anything other than this general level. The films themselves show, of course, nothing which - in theory at least - was not known before regarding change in the British population. A major criticism is the difficulty of obtaining a synoptic view - by studying one area only (for instance, the Greater London area or the Central Lowlands of Scotland), patterns of population change appear in both sections of the final film which can be interpreted to give meaningful results. Overall, the weaknesses in both sections as indicators of population change stem from two sources. First, are the limitations associated with the use of an interpolated data set. Secondly, the areal units used for choropleth mapping

are not the most ideal. The total field of study (the whole of Great Britain) is large, whilst the subdivisions of this vary greatly in both size and population: there is much internal inhomogeneity in each district and they are, in some cases at least, too coarse perhaps for meaningful patterns to emerge. This, of course, is not a criticism which is solely restricted to animated mapping: it also applies to all static maps showing change over time (see chapter 1), and even some raw census variables. The need for high spatial resolution to avoid the smoothing and confusing effects of variably sized areal units has often been made in the past (see, for instance, Rhind, 1975). In this instance, however, it would have been impossible to devise a more spatially detailed data set which was also consistent through time; even if that had proved possible its use would have involved much more computing (a factor of 20 to work at ward level) and the existing hardware could not have produced national level output (in mapping at this level, for instance, some wards would be smaller in size than the resolution of the FR80).

Despite substantial limitations, the animated film should not be dismissed as a method of portraying population change. The film enclosed with this thesis has had some dramatic success (for instance when shown to an audience of some 200 cartographers at the British Cartographic Society conference in Southampton in September, 1981). The nature of the film was determined by a complex interplay of data, hardware, software and cartographic techniques - to have used, for instance, county or regional level

data would have ensured lower cost, the ability to use more levels of shading and (possibly) the use of video taping as well as providing a simpler image with (possibly) area outlines to aid the user. Against this is the fact that data would have been much less meaningful, even than districts. An obvious solution is to narrow the window and look at only part of Britain. By working over a smaller area (for instance one metropolitan area) at a much finer areal resolution (Enumeration Districts or wards) more significant patterns could perhaps emerge. But this then loses an important aspect of the whole research - to show local variations in a national context. Also, there is a problem with sources of time series data of proven accuracy and reliability, especially at a large scale. The British census is easily accessible and covers a long time period (but both the temporal frequency and, for years prior to 1961, the areal resolution, are poor). Moreover, at the time of this research, only district boundaries were readily available in digitised form, although others of a finer resolution are now (in 1981) becoming available. Reconciling the two problems (data sources and resolution) posed a serious problem; the generation of a time series data set formed a major part of the research, much more than was originally intended. But aside from its use in animated filming, it also fills a gap in existing British historical population data, and thus the work was probably justified, even if the films themselves were of more limited success.

## 8.2 THE ANIMATED FILM AS A CARTOGRAPHIC TECHNIQUE

Despite its limitations for mapping this particular data set, the animated film which utilises choropleth mapping and is created in a manner described herein has a very definite place as a cartographic technique. As noted in the above section, the presentation of change in any data set by choropleth mapping is not easy. Aesthetically, but not perceptually, it may be preferable to use the block diagram. Yet data should always be presented on the same basis as which it was collected; thus in some cases, the animated choropleth map, even though less aesthetically pleasing, must be used because it 'fits' the data format.

Provided absolute simplicity exists in both content and design, then, the choropleth map has a role in animated mapping. It will not, however, succeed if anything more than basic measures or cartographic techniques are used; this was shown by the repeated failure of experiments (from both a perceptual and a technical point of view) utilising complex shading patterns, unduly large amounts of map text etc. From many hours both of map compilation done on a trial and error basis, and of film viewing, three guidelines may be determined. First, repeated viewing of films (not only by presenting the same maps twice in one film as was done here, but also by seeing the entire film several times) aids interpretation. Secondly, a soundtrack is important, even though it increases the overall cost both

directly (through the cost of the magnetic or optical stripe on the film) and indirectly (through the need to generate 24 instead of 16 frames / second). Finally, and most important, the film will only succeed if it is simple in content and design.

A further conclusion which may be drawn from this research is that animated filming is not beyond the reach of the average researcher. Much work in the past has been done with very sophisticated equipment on large budgets. But this need not be the case. This research was unduly complicated by the problems of the availability of time series data sets, and by the necessity of mounting a choropleth mapping package for map generation. But if a researcher is considering generating a film, he is presumably doing so because he already has a data set, and not, as in this research, because he wishes to study a cartographic technique. Thus the first problem does not arise. Secondly, no special equipment is needed. With the ever increasing number of choropleth mapping packages available (the reader should, for instance, compare IGU (1981) with its predecessor of 1978), it is unlikely a researcher will not have access to one of these. From that point, map generation should be a conceptually trivial, if sometimes practically lengthy, process. Access to a microfilm plotter has perhaps in the past been difficult, but not impossible, if only on a bureau basis. Moreover, the increasing sophistication of plotting devices means the user is not limited to this form of output: for some types of data, and as Moellering has shown (see section 3.2.1), the video

recorder may be used. Certain other forms of raster devices may also be suitable for use in animated filming (Jackson, 1981, pers.comm.)<sup>1</sup> but they are of limited resolution.

The question of cost, in any research, is an important one. Unfortunately the only realistic answer which can be given is that films made in this manner should not be expensive. Precise figures cannot be given - these are subject to the data set to be mapped, the method of mapping, and means of access to facilities. In Britain, costs will be less if the research is done within a University due to the essentially free nature of computer time to bona fide researchers at the present time. Costs will vary depending on type and ownership of the output device. An illustration of the importance of the latter is provided by this research. Plotting time on the FR80 is not charged according to real costs: external users are charged three times the internal user rate. Hence plotting of this film, charged at external user rate, was in the order of £900. At internal rate, such costs would have been reduced to about £300.

The creation of computer-animated films, then, is not difficult, and need not be expensive. Moreover, it does not demand great specialist knowledge; only basic cartographic and computing skills are required. As has been shown by this research, the success of the output depends not on the technique itself, but on the data. Given a good time series data set, the animated film could be of use in revealing dynamic patterns within it. Of the film enclosed with this thesis, it is

---

1. M. Jackson. E.C.U.

difficult to disagree with O'Dell's conclusion (page 10) that

'I show this film then not so much as a way of showing dynamic changes of population, but as an attempt which, while failing to reach the ideal, may lead others to a successful solution of a very difficult problem'.

As a method of showing population change in Britain during the 20th century it has significant imperfections. But, more generally, there is little doubt that the computer-animated film has an important role to play in the portrayal of time-changing phenomena.

BIBLIOGRAPHY

The following bibliography includes all works cited in the text, and also others, which, whilst not actually cited, are of relevance to this research.

Throughout the bibliography, periodical titles are abbreviated. The abbreviations used conform to those given in the World List of Scientific Periodicals and in the British Union-Catalogue of Periodicals.

Abler, A, J S Adams and P Gould, (1972). Spatial organization, a geographers view of the world. London, Prentice Hall.

Adams, T A, H M Mounsey and D W Rhind, (1980). 'Topographic maps from computer output on microfilm'. Cartogr J 17(1), 33-39.

Anderson, S E, (1971). 'Computer animation: a survey'. J Microgr 5, 13-20.

Anon, (1972). CALFORM manual. Harvard University, Laboratory for Computer Graphics and Spatial Analysis.

Audley, R J, R J Phillips and L Noyes, (1981). Legibility criteria for maps. Final report to the SSRC for project HR 2917/1.

Baxter, R S, (1976). 'Parsed data set of British local authority boundaries'. BRE Research Note N 138/76.

Benjamin, B, (1970). The Population Census. SSRC Review of current research no. 8. London, Heineman.

Bisco, R L (Ed), (1970). Data bases, computers and the social sciences. New York, Wiley-Interscience.

- Board, C, (1967). 'Maps as Models' in R J Chorley and P Haggett (Eds), Physical and information models in geography. London, Methuen.
- Brazier, S and Hayward, S, (1981). Comment on Masters and Shortridge, op cit.
- Burton, I, (1963). 'The quantitative revolution and theoretical geography'. Can Geogr VII(4), 151-162.
- Carter, P, W E Gardner, T F Smith and M J Jackson, (1977). 'An urban management information system using Landsat imagery'. Photogram Rec 9(50), 157-171.
- Chismon, H, (1977). 'The use of remote sensing data in cartography' in Barrett, E C and L F Curtis (Eds), Environmental remote sensing 2: Practices and problems. London, Edward Arnold.
- Clarke, J I, (1972). Population Geography. 2nd ed. Oxford, Pergamon Press.
- Clarke, J I, (1975). 'The abortive 1976 Census'. Area 7(2), 81-82.
- Clarke, J I and H M Mounsey, (1980). 'Population redistribution and regional policy in Britain'. Occ Paper no. 19/3. London, OPCS.
- COI, (1972). Local government in Britain. Central Office of Information Reference Pamphlet no. 1. London, HMSO.
- Cornwall, B and A H Robinson, (1966). 'Possibilities for computer animated films in cartography'. Cartogr J 3(2), 79-83.
- Cox, N J and D W Rhind, (1978). 'Geographical networks and automatic data processing'. University of Durham, Department of Geography Occ Pub (NS) 11.

- Cox, P R, (1970). Demography. 4th ed. Cambridge University Press.
- Craig, J, (1977). 'Grid references of centres of population, Great Britain 1971'. Occ Paper no. 1. London, OPCS.
- CRU/OPCS/GRO(S), (1980). People in Britain: a census atlas. London, HMSO.
- Dawson, J A and D J Urwin, (1976). Computing for Geographers. Newton Abbot, David and Charles.
- Department of the Environment, (n.d.). The definition of urban areas. Urban Information note 1.
- Dickinson, G C, (1973). Statistical mapping and the presentation of statistics. 2nd ed. London, Edward Arnold.
- Dickinson, R E, (1957). 'The geography of commuting: The Netherlands and Belgium'. Geogr Rev 47(4), 521-538.
- Dixon, O M, (1972). 'Methods and progress in choropleth mapping of population density'. Cartogr J 9(1), 19-29.
- Dobson, M W, (1973). 'Choropleth maps without class intervals: a comment'. Geogr Anal 5, 358-359.
- Duncan, O D, R P Cuzzort and B Duncan, (1961). Statistical geography: problems in analyzing spatial data. Illinois, Free Press of Glencoe.
- Dutton, G, (1978). American Graph Fleeting: United States Population Growth 1790-1970. Harvard University, Lab. for Computer Graphics and Spatial Analysis.
- Evans, I S, (1977). 'The selection of class intervals'. Trans Inst Br Geogr NS 2(1), 98-124.
- Fawcett, C B, (1935). 'Population maps'. Geogr J 86(1), 142-159.

- Fay, W T and R C Klove, (1970). 'The 1970 Census'. Prof Geog 22, 284-289.
- Foley, J. D, (1978). 'A standard computer graphics subroutine package'. Comput & Struct 10, 141-147.
- Fordham, R C, (1975). 'Urban land use change in the UK during the second half of the twentieth century'. Urban Stud 12, 71-84.
- Frosh, R L, (1977). 'An application of orbital imagery to inter-censal population estimation in Western Illinois - South Eastern Iowa' in Shahrokhi, F, op cit. Vol. V.
- Geddes, A, (1942). 'The population of India: variability of change as a regional demographic indicator'. Geogr Rev XXXII, 562-573.
- Geddes, A, (1954). 'Variability of change of population in the United States and Canada, 1900 - 1951'. Geogr Rev XLIV, 88-100.
- Gibbs, J N and R S Howell, (1972). 'Dutch Elm Disease Survey 1971'. Forest Rec, Lond 82, 3-34.
- Gibbs, J N and R S Howell, (1974). 'Dutch Elm Disease Survey 1972-3'. Forest Rec, Lond 120, 3-26.
- Gould, P and R White, (1974). Mental Maps. Middlesex, Penguin Books.
- Grassie, D N D, (forthcoming). Optimum isarithm interpolation in digital modelling. Unpublished Ph.D. thesis. University of Durham, Department of Geography.
- GRO/GRO(S), (1968). Census 1961: Great Britain General Report. London, HMSO.
- Hackathorn, R J, (1977). 'ANIMA II: A 3-D color animation system'. Comput Graphics & Image Process 11, 54-64.

- Hägerstrand, T, (1967). 'The computer and the geographer'. Trans Inst Br Geogr 42, 1-19.
- Hanson, A H and M Wallis, (1972). Governing Britain. London, Fontana.
- Harley, J B, (1974). Ordnance Survey maps: a descriptive manual. Southampton, Ordnance Survey.
- Harris, R, (1979). 'Access to Landsat data'. Area 11(1), 63-6.
- Haviland, A A, (1870). 'A proposed rearrangement of the registration districts of England and Wales, for the purpose of facilitating scientific enquiry'. Rep, Br Ass Advmt Sci, 40th meeting, Liverpool.
- Herbert, E S, (1960). Report of the Royal Commission on Local Government in Greater London, 1957-1960: Chairman Sir Edwin Savory Herbert, KBE. London, HMSO. Cmd. 1164.
- Hubbard, J C E and B H Grimes, (1974). 'Coastal vegetation surveys' in Barrett, E C and L F Curtis (Eds), Environmental Remote Sensing: applications and achievements. London, Edward Arnold.
- Huggins, W H and D R Entwisle, (1969). 'Computer animation for the academic community'. Proc, SJOC AFIPS, 623-627.
- Hunt, A J, (1952). 'Urban population maps'. Town Plann Rev XXIII, 238-248.
- IGU, (1981). Computer software for spatial data handling. IGU Commission on Geographical Data Sensing and Processing, Ottawa, Canada.
- Jackson, P W, (1976). Local Government. 3rd ed. London, Butterworths.
- Jenks, G F, (1963). 'Generalization in statistical mapping'. Ann Ass Am Geogr 53, 15-26.

Jeffrey, M, H O'Hare and C Board, (1975). 'Choropleth mapping on the microfilm plotter'. Int Yearbook Cartogr 15, 39-46.

Jones, H J M, H B Lawson and L Newman, (1973). 'Population Census: some recent British developments in methodology'. Jl R Statist Soc A 136(4), 505-538.

Kadmon, N, (1975). 'Data-bank derived hyperbolic-scale equitemporal town maps'. Int Yearbook Cartogr 15, 47-54.

Kallis, S A, (1971). 'Computer animation techniques'. J Soc Motion Pict Telev Engrs 80, 145-148.

Karssen, A J, (1980). 'The artistic elements in map design'. Cartogr J 17(2), 124-127.

Knowlton, K, (1965). 'Computer produced movies'. Science, NY 150, 1116-1120.

Kolers, P and M von Grunau, (1976). 'Colour and shape in apparent motion'. Vision Res 16, 329-335.

Kosinski, L A, (1979). Population maps. Specialisation Seminal Series no. 27, Population Research Laboratory, Department of Sociology, University of Alberta.

Lee, C, (1971). 'Data banks for planning'. Plann Outl NS 10, 24-35.

Levy, M, H Pollack and P Pomeroy, (1970). 'Motion picture of the seismicity of the Earth, 1961-1967'. Bull, Seism Soc Am 60(3), 1015-1016.

Liebenburg, E, (1976). 'SYMAP: its uses and abuses'. Cartogr J 13(1), 26-36.

London County Council, (1950). Statistical Abstract for London, 1939-1948, XXXI. London, County Hall.

- Manvell, R and J Halas, (1971). The techniques of film animation. London, The Focal Press.
- Massey, J S, (1979). 'Automated production of colour animated movies showing computer-produced maps'. Conf. on Computer Graphics and Spatial Analysis Adelaide, 13-15 Aug.
- Masters, R and J Shortridge, (1981). 'Population estimates from the Electoral Register: review article based on experience in Shropshire'. BURISA 49, 3-9.
- McEvedy, C and R Jones, (1978). Atlas of world population history. Middlesex, Penguin Books.
- Menmuir, P, (1974). 'The automatic production of weather maps'. Cartogr J 11(2), 12-18.
- Menneer, P, (1976). 'The cancellation of the 1976 Census of Population: Filling the gap'. J Market Research Soc 18(2), 93-9.
- Meyer, M A, F R Broome and R H Schweitzer, (1975). 'Colour statistical mapping at the U.S. Bureau of the Census'. Am Cartogr 2(2), 100-117.
- Mitchell, B R and P Deane, (1962). Abstract of British Historical Statistics. Cambridge University Department of Applied Economics Monograph no. 17. Cambridge University Press.
- Mitchell, B R and H G Jones, (1971). Second abstract of British Historical Statistics. Cambridge University Department of Applied Economics Monograph no. 18. Cambridge University Press.
- Moellering, H, (1973). 'The automatic mapping of traffic crashes'. Surv Mapp XXXIII(4), 467-477.
- Moellering, H, (1976). 'The potential uses of CAF'. Accident Anal and Prev 8, 215-227.

Moellering, H, (1978). 'An approach to the real-time cartographic animation of 3-D objects'. Ninth Int. Conf. on cartography ICA, University of Maryland, USA.

Moellering, H, (1980). 'Strategies of real-time cartography' Cartogr J 17(1), 12-15.

Monkhouse, E J and H R Wilkinson, (1971). Maps and Diagrams. London, Methuen.

Morrey, C R, (1973). 'The changing population of the London Boroughs'. GLC Research Memorandum 413. Department of Planning and Transportation Intelligence Unit.

Morrison, A, (1971). 'Experimental maps of road travel speed'. Cartogr J 8(2), 115-131

Muehrcke, P C, (1979). Map use: reading, analysis and interpretation. Madison, Wisconsin, J P Publications.

NAG, (1981). NAG Fortran Library Manual, Mark 8. Numerical Algorithms Group.

Nasatir, D, (1973). 'Data archives for the social sciences: purposes, operations and problems'. UNESCO Reports and papers in the social sciences SS/CH 26.

Norris, P and H M Mounsey, (1982). 'Analysing change through time' in Rhind, D W (Ed), A census users handbook, op cit.

Olsen, J M, (1975). 'Experience and the improvement of cartographic communication'. Cartogr J 12(2), 94-108.

OPCS, (1975a). New Districts for Old. Vol 3, Scotland. Ed. R M Blunden and Sheila Gray. London, HMSO.

OPCS, (1975b). Reorganisation of Local Government areas; correlation of old and new areas. London, HMSO.

- OPCS, (1978a). 'Changes in population estimates'. Popul Trends 12, 2-3.
- OPCS, (1978b). 'Population estimates, 1971-77'. Popul Trends 13, 10-12.
- OPCS, (1979). 'Geographical area units'. Popul Trends 15, 16-22.
- OPCS, (1980a). Census Topics 1801-1981. London, OPCS.
- OPCS, (1980b). 'Extending the electoral register canvass: a feasibility study'. Popul Trends 21, 20-25.
- OPCS, (1980c). Libraries in the United Kingdom holding census data. London, OPCS.
- OPCS, (1980d). 'Local Authority population estimates methodology'. Occ Paper no. 18.
- OPCS, (1980e). Population and health statistics in England and Wales. London, OPCS.
- OPCS/GRO(S), (1977). Guide to the census reports, Great Britain 1801 - 1966. London, OPCS.
- Openshaw, S, (1977). 'A geographical solution to scale and aggregation problems in region-building, partitioning and spatial modelling'. Trans Inst Br Geogr NS 2(4), 459-472.
- Owen, D W, P Dodds and A E Gillespie, (1980). Employment in the Northern Region. Unpublished report to the MSC.
- Place, J L, (1976). 'Monitoring change in land use over large areas'. US Geol Survey Prof Paper 929.
- Pollack, H, (1969). 'A numerical model of Grand Canyon'. Four Corners Geol Soc Guide 61-62.

Provin, R W, (1977). 'The perception of numerosness on dot maps'. Am Cartogr 4(2), 111-125.

Rase, W D, (1980). Subroutines for plotting graduated symbol maps. EDV Report 2/1980. Bonn, BFLR.

Redlich, J and F W Hurst, (1970). The history of local government in England. 2nd ed. Ed. B Keith Lucas. London, Macmillan.

Rehder, J B, (1974). 'The uses of ERIS-I imagery in the analysis of landscape change' in Shahrokhi, F, op cit. Vol. III.

Rhind, D W, (1975). 'The reform of areal units'. Area 7(1), 1-3.

Rhind, D W, (1977). 'Computer Aided Cartography'. Trans Inst Br Geogr NS 2(1), 71-97.

Rhind, D W, (1978). An environmental data manipulation and mapping system for the EEC. Unpublished report to the EEC. University of Durham, Department of Geography.

Rhind, D W (Ed), (1982). A Census Users Handbook. London, Methuen.

\*

Rhind, D W and R Hudson, (1980). Land Use. London, Methuen.

Rhind, D W, K Stanness and I S Evans, (1977). 'Population distribution around selected British cities' Census Research Unit Working Paper 11. University of Durham, Department of Geography.

Riffe, P D, (1970). 'Conventional map, temporary map or non-map?'. Int Yearbook Cartogr 10, 95-103.

Robertson, I M L, (1969). 'The census and research: ideals and realities'. Trans Inst Br Geogr 48, 173-187.

\* Rhind, D.W, I.S.Evans & M. Viswalingem (1980). 'Making a national atlas of population by computer'. Cartogr. J. 17(1), 3-11.

- Robinson, A H, (1971). 'The genealogy of the isopleth'. Cartogr J 8(1), 49-53.
- Robinson, A H and B B Petchenik, (1975). 'The map as a communication system'. Cartogr J 12(1), 7-15.
- Robinson, A H, R D Sale and J L Morrison, (1978). Elements of cartography. 4th ed. New York, John Wiley.
- Rose, R, (1974). 'The dynamics of data archives'. Soc Sci Inf 13(6), 91-107.
- Rosing, K E and P A Wood, (1971). Character of a conurbation. London, University of London Press.
- Rowles, R A, (1978). 'Perception of perspective block diagrams'. Am Cartogr 5(1), 31-44.
- Schmidt, A H and W A Zafft, (1975). 'Programs from the Harvard University Laboratory for Computer Graphics and Spatial Analysis' in Davis, J C and M J McCullagh (Eds), Display and analysis of spatial data. London, John Wiley.
- Shahrokhi, F, (1975, 1977). Remote Sensing of Earth Resources. Tullahoma, Tennessee, University of Tullahoma Space Institute.
- Short, J R, (1978). 'Population turnover: problems in analysis and an alternative method'. Area 10(3), 231-235.
- Soot, S, (1975). 'Methods and measures of centrography: a critical survey of geographic applications'. Occ Pubs of the Department of Geography no. 8. Graduate Students Association, University of Illinois at Urbana, Champaign.
- Sorrell, P, (1974). 'Map design - with the young in mind'. Cartogr J 11(1), 82-90.
- Stewart, J Q and W Warntz, (1958). 'Physics of population distribution'. J Reg Sci 1(1), 99-123.

- Survey Archive, (n.d.). Survey Archive Data Catalogue. SSRC Survey Archive, University of Essex, Colchester.
- Taylor, P, (1977). Quantitative methods in geography. Boston, Houghton-Mifflin.
- Thrower, N J W, (1959). 'Animated cartography'. Prof Geogr XI(6), 9-12.
- Thrower, N J W, (1961). 'Animated cartography in the U.S'. Int Yearbook Cartogr 1, 20-30.
- Tobler, W R, (1969). 'Satellite confirmation of settlement size co-efficients'. Area 3(1), 30-34.
- Tobler, W R, (1970). 'A computer movie'. Econ Geogr 46(2), 234-240.
- Tobler, W R, (1973). 'Choropleth maps without class intervals?'. Geogr Anal 3, 358-360.
- Tobler, W R, (1981). 'A model of geographical movement' Geogr Anal, 13(1), 1-20.
- Tomlinson, R F (Ed), (1972). Geographical data handling. IGU Commission on Geographical Data Sensing and Processing. Proc. 2nd. Symposium on Geographical Information Systems, Ottawa, Canada.
- van Demark, P, (1977). User's primer for Wismap 2. University of Wisconsin, Cartography Laboratory.
- Visvalingam, M, (1978). 'The signed chi-square measure for mapping'. Cartogr J 15(2), 93-98.
- Waugh, T C, (1974). Geographic data in a systems environment. Unpublished M.Phil. thesis, University of Edinburgh, Department of Geography.

Waugh, T C, (1978). 'A parameter driven language for use in application systems'. Proc Advanced Symp on Topological Data Structures. Harvard University, Laboratory for Computer Graphics and Spatial Analysis.

Waugh, T C, (1979). GIMMS reference manual. Inter-University / Research Council Series report no. 30.

Waugh, T C, (1980). 'The development of the GIMMS computer mapping system' in Taylor, D R F (Ed), The computer in contemporary cartography. Chichester, John Wiley.

Williams, R L, (1976). 'The misuse of area in mapping census-type numbers'. Hist Methods Newsl 9(4).

Wilson, J R, C Blackman and G W Spann, (1977). 'Land use change detection using Landsat data'. in Shahrokhi, F, op cit Vol. V.

APPENDIX A: The population data set

Chapters 4 and 5 described the creation of a population data set; the results of this process are set out on the following pages. The order in which the data are listed is hierarchical and alphabetical: region by county by district.

LOCAL AUTH. NAME	1901	1911	1921	1931	1951	1961	1971	1981
Cambridge	50535	55889	61468	69910	81500	95527	98840	90440
East Cambridge	39243	40774	38964	40532	44925	45124	49109	53629
Fenland	45401	50394	53911	56211	61998	62790	64682	67215
Huntingdon	47725	48842	48632	48157	59824	68218	96986	123450
Peterborough	49523	53644	56635	63405	77484	90957	105637	132464
South Cambridgeshire	50828	52723	48975	50698	65161	73939	90413	107979
Cambridgeshire	283256	302267	308583	328913	390892	436555	505667	575177
Breckland	58536	59493	56257	54450	62851	61895	76417	96444
Broadland	33856	35152	35072	39273	55304	65919	86532	98323
Great Yarmouth	63615	69034	74362	70953	68985	72591	75763	80820
North Norfolk	64152	67033	69646	66190	77358	73855	74238	82037
Norwich	114392	121908	121157	127154	122368	120953	122094	122270
South Norfolk	57675	57551	55527	56358	62958	64690	80706	92842
West Norfolk	83791	87835	91830	90627	101695	106009	110043	120754
Norfolk	476020	498008	503853	505005	551518	565915	625792	693490
Babergh	48342	49377	47851	45493	47618	47132	63249	73697
Forest Heath	23353	23296	22328	22160	29012	31818	39589	51907
Ipswich	68120	75515	81121	89784	107681	117528	123301	120447
Mid Suffolk	55100	55447	53148	53168	54521	54264	60722	69787
St. Edmundsbury	49686	49859	45708	44971	51094	55606	71353	86054
Suffolk Coastal	60706	66150	68586	68279	74561	82960	89123	95223
Waveney	65328	71628	78387	74164	74617	77825	90680	99239
Suffolk	370636	391270	397127	398019	439105	467130	538018	596354
East Anglia	1129912	1191545	1209563	1231937	1381515	1469600	1669477	1865021
Amber Valley	75109	84275	89429	93740	103897	102811	105261	109379
Bolsover	48896	70161	72214	73583	73001	75356	72315	70423
Chesterfield	67052	76958	80269	88672	93461	94186	96120	96710
Derby	146728	153509	165394	183663	196256	212720	219582	215736
Erewash	47733	64190	65887	69687	87252	92722	99682	101838
High Peak	65876	72730	74232	74521	71782	70280	79236	82142
NE. Derbyshire	45500	49799	54785	55412	67203	81025	88394	96547
South Derbyshire	39284	42736	42977	45286	54440	55111	60948	67669
West Derbyshire	57252	60839	60312	61486	62745	62596	65073	66485
Derbyshire	593433	675194	705503	746050	810037	846807	886611	906929
Blaby	9309	11391	16119	21964	38688	50539	74242	77210
Charnwood	53494	58333	64147	71542	89351	104032	125596	134204
Harborough	27404	30329	30566	31866	39077	42494	52964	60766

LOCAL AUTH. NAME	1901	1911	1921	1931	1951	1961	1971	1981
-----	----	----	----	----	----	----	----	----
Hinckley and Bosworth	36668	42567	44487	49433	61525	65020	75374	87518
Leicester	223970	241980	242415	263691	285626	288065	284208	279791
Melton	25206	27881	27053	28191	32730	34435	38894	43260
NW. Leicestershire	45806	52423	57191	59277	62576	64487	71044	78589
Dadby and Wigston	10153	11499	12453	15671	21576	33577	49780	50569
Rutland	19188	20499	18376	17401	20537	23504	27469	30670
Leicestershire	451199	496899	512807	559036	651687	706153	799571	842577
Boston	35484	37757	38005	40444	45311	47339	48823	52634
East Lindsey	75471	78076	83401	81173	92559	90566	94698	104546
Lincoln	51378	60511	66921	67167	70931	77693	74269	76660
North Kesteven	39046	42120	42886	44721	57939	59742	72720	78527
South Holland	41991	44972	47713	51682	56244	55988	56867	61734
South Kesteven	62669	66392	64299	64844	71781	75048	85560	97600
West Lindsey	54804	57744	55978	54638	61848	62281	70560	75859
Lincolnshire	360844	387573	399203	404669	456613	468657	503497	547560
Corby	5072	5477	5499	5596	21454	40466	52694	52667
Daventry	31602	31821	32016	31818	36072	37354	48091	57656
East Northamptonshire	44796	47151	46369	45680	50561	51720	56739	60843
Kettering	45784	48670	47904	50405	57635	59484	65794	71314
Northampton	98425	101508	101848	106855	115453	123320	133565	156848
South Northamptonshire	33166	33065	32024	31091	37418	41593	55749	64057
Wellingborough	35663	36108	36742	38030	41125	44121	55991	64147
Northamptonshire	294506	303797	302404	309474	359721	398057	468623	527532
Ashfield	53042	68032	76554	80101	91856	94901	101958	106521
Bassetlaw	50119	56721	59830	73325	84636	90295	97434	101970
Broxtowe	34292	39608	45787	50748	76729	86945	98365	102801
Gedling	29631	38465	42960	51139	68200	80568	96275	104134
Mansfield	28576	52280	65383	70811	80064	84892	95394	99349
Newark	44102	47203	47920	64838	73905	83952	98837	104139
Nottigham	245201	266252	264665	277405	307849	311770	300532	271080
Rushcliffe	29142	35197	37649	43964	56932	67669	85775	92587
Nottighamshire	514107	603761	640749	712330	840174	900989	974573	982631
East Midlands	2214089	2467224	2560666	2731559	3118232	3320663	3632875	3807229
Hartlepool	86433	86003	92080	91556	91788	96708	99512	94359
Langbaurgh	81885	96033	105107	105649	113525	130585	147571	149508
Middlesbrough	85635	99101	110160	120899	134429	149937	158905	149770
Stockton-on-Tees	84236	97435	110616	120426	133527	149267	161778	172138

LOCAL AUTH. NAME	1901	1911	1921	1931	1951	1961	1971	1981
Cleveland	338188	378572	417964	438531	473269	526497	567766	565775
Allerdale	94756	94589	98953	91176	95429	95369	94943	95664
Barrow-in-Furness	70852	74686	86732	76691	77874	75243	75269	72635
Carlisle	78033	78437	80094	83353	97643	100745	100847	100692
Copeland	68689	68254	70271	64746	67724	73519	71794	72788
Eden	46064	44661	43891	44156	43877	42446	41971	43984
South Lakeland	77263	75766	81096	77148	81851	82808	91309	97664
Cumbria	435656	436394	461036	437270	464398	470130	476133	483427
Chester-le-Street	30903	39484	44873	44075	42580	43272	48303	51719
Darlington	50736	62715	70530	75706	89355	93450	98150	97788
Derwentside	82386	105567	111175	110093	102837	99889	92220	88132
Durham	66697	76515	77387	73698	72542	75439	81752	85190
Easington	50318	74843	91141	105780	107347	110237	108234	100717
Sedgefield	58265	74742	80827	75905	77833	84626	88436	92887
Teesdale	29433	31412	32414	27479	28103	26385	24644	24425
Wear Valley	83749	91823	94786	84292	76289	71967	65439	63870
Durham	452483	557098	603129	597030	596889	605263	607174	604728
Alnwick	30330	30333	33450	29620	29893	29812	27931	28734
Berwick-upon-Tweed	34135	32989	33507	30044	29847	27857	25778	26230
Blyth Valley	43735	51010	53558	54650	56456	57241	60615	76787
Castle Morpeth	22640	27124	29147	30245	35745	40789	47630	50570
Tynedale	50230	53309	58576	53813	53158	52063	53144	55087
Wansbeck	38201	56930	65758	66110	67544	66555	64455	62497
Northumberland	219271	251693	273993	264481	272644	274315	279556	299905
Gateshead	184791	220306	235991	235995	222481	223310	224892	211658
Newcastle upon Tyne	274628	306228	317120	330302	346336	338348	308063	277674
North Tyneside	109842	139687	156611	162783	180641	207896	207940	198266
South Tyneside	166791	178783	193951	189193	174726	185111	177000	160551
Sunderland	233264	260309	277479	282673	277207	289181	293797	295096
Tyne and Wear	969317	1105314	1181151	1200944	1201391	1243848	1211694	1143245
North	2414915	2729071	2937273	2938256	3008591	3120053	3142323	3097080
Chester	71512	74932	77612	80711	97417	102053	115608	116157
Congleton	37991	39518	40616	42684	50575	55346	70902	79028
Crewe and Nantwich	74502	79138	80125	80995	89135	91295	97100	98217
Ellesmere Port	11461	18658	23628	31134	42788	56582	78419	81549
Halton	54936	60138	62763	65895	76769	82249	95463	121972

LOCAL AUTH. NAME	1901	1911	1921	1931	1951	1961	1971	1981
Macclesfield	78371	81609	80360	85759	99571	112357	139878	149003
Vane Royal	61381	65049	66547	69926	82934	88326	105909	111521
Warrington	94352	108229	112972	120850	147972	141573	163280	168846
Cheshire	484508	527272	544622	577950	687162	729779	866556	926293
Bolton	253361	271131	267978	267418	254039	251211	259533	260830
Bury	126543	133422	131923	137960	151162	152112	174557	176568
Manchester	649246	719520	735562	766222	702941	661779	543867	449168
Oldham	228068	247911	248895	240603	221055	215484	223985	219817
Rochdale	162657	176354	175739	176691	170449	189649	203148	207255
Salford	307581	333908	343063	338653	305600	294200	279907	243736
Stockport	134045	158602	165293	180746	223473	255817	292271	289730
Tameside	190145	197117	192904	189536	204480	204047	220871	217341
Trafford	95700	121408	129118	155527	205312	223977	227899	221406
Wigan	256518	278897	283321	273744	277688	271633	302963	308927
Greater Manchester	2403868	2638269	2673801	2727104	2716204	2719913	2728997	2594778
Blackburn	172986	179457	170849	165323	148883	143254	141142	141758
Blackpool	52072	64771	102845	107032	147870	153385	151909	147854
Burnley	119338	131578	125976	120134	104622	99317	96560	93779
Chorley	56840	62429	62768	62825	67297	67207	77808	90986
Fylde	24469	30659	39440	39935	54054	58578	67049	68440
Hyndburn	93271	100327	97328	92060	82420	80077	80599	78860
Lancaster	75037	76723	84808	88229	112001	115018	123663	120914
Pendle	87306	104494	106256	101768	90684	86304	85619	85573
Preston	125430	131727	132241	137647	145351	141763	134687	125886
Ribble Valley	35075	37968	38880	41498	42468	43605	51312	51968
Rossendale	85515	84147	79686	77961	69078	65447	61968	64480
South Ribble	30145	34002	36602	42362	55799	68220	86162	97164
West Lancashire	36760	39586	40366	41282	52081	61000	91428	106735
Wyre	31128	37405	42866	52757	65990	78007	94851	97721
Lancashire	1025372	1115274	1160916	1170814	1238599	1261188	1344762	1372118
Knowsley	20740	22056	24935	27309	92962	156607	194610	173356
Liverpool	711683	753831	803493	853985	789208	745471	609904	510306
St. Helens	121751	138291	146450	152585	167310	169518	188762	189909
Sefton	182272	211364	232201	243686	274870	294866	307668	300011
Wirral	196885	252339	290077	309008	338382	351724	355602	339488
Merseyside	1233332	1377879	1497157	1586575	1662733	1718186	1656545	1513070
North West	5147080	5658694	5876496	6062443	6304698	6429066	6596860	6406259

LOCAL AUTH. NAME	1901	1911	1921	1931	1951	1961	1971	1981
Luton	42877	57070	64540	73891	113588	140044	161405	164049
Mid Bedfordshire	46082	47120	48377	49966	63401	69117	89829	102063
North Bedfordshire	60983	66181	67875	69113	90494	103815	124554	132084
South Bedfordshire	23922	26480	28042	29989	45951	69730	88489	106790
<b>Bedfordshire</b>	<b>173864</b>	<b>196850</b>	<b>208835</b>	<b>222958</b>	<b>313434</b>	<b>382706</b>	<b>464277</b>	<b>504986</b>
Bracknall	15858	17589	18889	17996	23187	43763	64141	81885
Newbury	45352	49194	48875	51472	63766	82470	104470	120231
Reading	81340	87826	92410	97135	113975	120508	132945	132037
Slough	17171	21593	24227	38461	73584	92755	99330	97008
Windsor and Maidenhead	57869	61748	67316	69204	83037	107375	124054	130054
Wokingham	18038	21045	23063	27530	44505	63223	99670	113938
<b>Berkshire</b>	<b>235625</b>	<b>258995</b>	<b>274780</b>	<b>301801</b>	<b>402054</b>	<b>510096</b>	<b>624612</b>	<b>675153</b>
Aylesbury Vale	55987	58376	59499	61587	80590	90435	114406	132709
Chiltern	21744	27527	32168	39311	53338	71739	88917	91728
Milton Keynes	35797	38364	37806	36328	43183	48675	66800	123782
South Buckinghamshire	13708	16767	20067	25830	39444	57589	63726	62182
Wycombe	45306	49591	53670	62685	87026	109424	142375	155591
<b>Buckinghamshire</b>	<b>172541</b>	<b>190627</b>	<b>203211</b>	<b>225742</b>	<b>303583</b>	<b>377863</b>	<b>476222</b>	<b>565992</b>
Brighton	127079	135395	148413	148720	158068	163159	161351	146134
Eastbourne	44449	53620	63126	58644	57821	60918	70921	77608
Hastings	66471	62166	67515	66321	65522	66478	72410	74803
Hove	42650	49854	55726	64520	83109	88747	91222	84740
Lewes	33687	35502	37041	40173	49023	56560	72201	77507
Rother	40454	43924	48884	52012	60537	63968	71046	75278
Wealden	55595	62238	65481	67345	80227	86400	108309	116498
<b>East Sussex</b>	<b>410387</b>	<b>442696</b>	<b>486186</b>	<b>497735</b>	<b>554307</b>	<b>586230</b>	<b>647460</b>	<b>652568</b>
Basildon	13153	16038	13217	28464	44201	89667	130581	152301
Braintree	52099	53555	53308	58775	67877	74502	93384	111818
Brentwood	17595	21782	26540	30760	39545	61216	73700	71978
Castle Point	5243	6575	8048	15763	31140	48000	74674	85533
Chelmsford	34338	38715	43994	52928	73618	93683	122829	138318
Colchester	60553	66642	65825	72949	85500	93810	118156	133681
Epping Forest	34812	37444	37452	43322	82679	104367	114099	116204
Harlow	3110	3384	3823	4186	5771	53680	78087	79253
Maldon	22395	24796	26003	25522	28654	31017	40536	47726
Rochford	8327	10468	13840	20516	28997	49350	68469	73540
Southend-on-Sea	38108	77288	113753	129923	151806	165093	162770	156683
Tendring	45181	53600	63141	62165	75522	80381	102413	113819
Thurrock	32427	39199	48380	61168	81287	113120	123837	126870
Uttlesford	37996	38982	36885	36933	42579	45730	54493	61341

LOCAL AUTH. NAME	1901	1911	1921	1931	1951	1961	1971	1981
Essex	405334	488473	554215	643375	839177	1103616	1358028	1469065
Corp. of London	26882	19619	14158	11054	5324	4767	4245	5893
Barking	27225	38881	44627	138006	189430	177092	160800	150175
Barnet	76080	118100	147139	231156	320438	318373	306560	292331
Bexley	53112	59978	76591	95552	205400	209893	217076	214818
Brent	120046	165693	184232	250879	311081	295899	280657	251257
Bromley	100318	116062	126729	164176	267771	293394	305377	294451
Camden	376623	353201	340962	325995	258318	245707	206737	171563
Croydon	143840	188690	212919	270627	310433	323927	333870	316557
Ealing	94985	164694	181545	225673	310690	301646	301108	280042
Greenfield	104589	154709	167047	201528	288112	273857	268004	258825
Enfiewich	210563	214878	238282	244922	235549	229810	217664	211806
Hackney	388953	384544	378813	363638	265349	257522	220279	180237
Hammersmith	249487	274767	281474	286506	241431	222124	187195	148054
Haringey	208951	271341	285400	307446	277316	259156	240078	203175
Harrow	24106	42030	49271	96711	219494	209083	203215	195999
Havering	25763	33130	38478	77284	192094	245598	247696	240318
Hillingdon	29218	38580	48194	84012	210312	228361	234888	229183
Hounslow	84891	109432	117605	155590	211075	208893	206956	199782
Islington	436413	415288	406983	391738	271002	261232	201874	159754
Kensington and Chelsea	250429	238664	239807	239763	219117	218528	188227	138759
Kingston upon Thames	56417	68731	74409	93408	146615	146010	140525	132411
Lambeth	380707	403882	414743	416259	346964	341624	307516	245739
Lewisham	237852	270292	286979	326899	303071	290582	268474	233225
Merton	61946	98479	114310	157669	200140	189013	177324	164912
Newham	365669	424907	446701	439155	294017	265388	237390	209290
Redbridge	65800	112279	123897	178887	256902	250080	239889	225019
Richmond	94877	123372	141603	161070	188100	180949	174628	157867
Southwark	596238	579100	571305	534586	337638	313413	262138	211708
Sutton	37277	55118	60308	103332	176151	169095	169494	168407
Tower Hamlets	597061	570391	529724	488576	230790	205682	165776	142975
Waltham Forest	198375	257461	267582	283416	275468	248591	234680	215092
Wandsworth	321935	373203	384673	392660	330883	335451	302258	255723
Westminster City	460247	420934	390263	372184	300332	271703	239748	190661
GLC	6506889	7160441	7386755	8110358	8196807	7992443	7452346	6696008
Basingstoke	35958	38838	40080	43826	52750	68324	103427	129899
East Hampshire	31154	42179	40470	46021	58981	63018	79493	89831
Eastleigh	23111	30917	32473	38161	51432	61213	78570	92491
Fareham	14054	16466	18926	22047	42772	58363	80412	88274
Gosport	30500	35191	35830	38673	58531	62512	76125	77276
Hart	17288	20012	21801	24141	31493	37426	61692	75654
Havant	13639	16140	17511	22951	35668	74607	109332	116649
New Forest	39672	45510	49238	60761	86257	107067	130877	145123
Portsmouth	192532	235511	248280	252651	233797	215132	197440	179419
Rushmoor	45417	52618	44911	54371	64622	63191	74873	78107

LOCAL AUTH. NAME	1901	1911	1921	1931	1951	1961	1971	1981
Southampton	130054	151834	167991	183741	190337	205081	215127	204406
Test Valley	31973	39346	37437	43056	58151	61539	79902	90853
Winchester	45160	50414	53393	54469	64817	73186	85734	88385
Hampshire	650507	774974	808335	884872	1029612	1150653	1373008	1456367
Broxbourne	19519	20887	21132	24330	36717	53226	71077	79562
Dacorum	33268	36775	37953	42380	58487	96821	119182	128801
East Hertfordshire	49338	53470	53999	55642	67826	79901	102219	106994
Hertsmere	13189	16995	18715	26963	53298	87821	91190	87752
North Hertfordshire	32842	41274	46941	54315	72008	85481	99415	106986
St. Albans	32779	42898	46696	55993	86626	107105	121204	124867
Stevenage	4199	5268	5438	5911	7215	43014	67084	74381
Three Rivers	15679	18450	19853	25596	59120	77153	80907	77836
Watford	30784	42723	48217	58527	73092	75569	78410	74356
Welwyn Hatfield	10195	11631	11911	23653	47059	81757	93939	93000
Hertfordshire	241797	290373	310860	373313	561445	787850	924632	954535
Medina	49561	53117	54051	53358	57693	56316	64423	67569
South Wight	32857	35069	40615	35096	37932	39436	45089	50623
Isle of Wight	82418	88186	94666	88454	95625	95752	109512	118192
Ashford	42418	44730	46156	49069	56378	61914	79083	85832
Canterbury	56607	59169	65297	70172	82517	91182	110130	116829
Dartford	36557	42780	47220	51074	65792	78334	83333	78236
Dover	80532	85141	84721	91150	92426	93962	98969	100751
Gillingham	46496	56214	58289	61583	70676	72910	86862	93741
Gravesham	47720	50312	55392	60312	71093	84122	96461	95841
Maldstone	61613	64820	67373	73863	88665	97117	121220	130053
Rochester-upon-Medway	78691	85144	86430	86354	101490	117046	139296	143384
Sevenoaks	44366	46768	49904	55605	69752	88237	99535	109402
Shepway	58681	64380	69448	71113	73217	73839	82016	86074
Swale	72796	73398	77812	75953	82293	84345	100897	109506
Thanet	68475	78507	111690	91798	97958	104110	114870	121150
Tonbridge and Malling	45789	48222	50059	51221	61384	69306	93385	96205
Tunbridge Wells	65745	69336	68315	69436	77512	82140	93406	96051
Kent	806488	868927	938112	958701	1091153	1198564	1399463	1463055
Cherwell	41884	42655	40343	42343	61489	69930	94365	106947
Oxford	57773	62711	66984	80242	98544	106168	108824	98521
South Oxfordshire	47659	51275	53745	58572	85376	101023	133624	128596
Vale of White Horse	37708	39523	39978	41380	62244	76875	93325	100749
West Oxfordshire	40728	41780	39191	40149	48699	55764	75036	80266
Oxfordshire	225754	237945	240243	262684	356351	409762	505172	515079

LOCAL AUTH. NAME -----	1901 ----	1911 ----	1921 ----	1931 ----	1951 ----	1961 ----	1971 ----	1981 ----
Elmbridge	34386	42349	49029	57900	89689	106211	115552	110683
Epsom and Ewell	14513	23866	22808	35053	68102	71147	72305	69230
Guildford	44056	50361	55163	65613	93031	108852	118752	120072
Mole Valley	26038	30005	31353	39642	58871	72126	77531	76614
Reigate and Banstead	45289	52677	54634	65416	92903	115791	119627	116191
Runnymede	25413	27337	29290	34006	55589	70949	75683	71082
Spelthorne	21636	23892	26819	34609	63436	83263	96902	92898
Surrey Heath	14843	22083	23409	27434	34542	44720	66045	76519
Tandridge	30297	37159	40159	47462	64243	75212	79792	75845
Waverley	47615	54575	58576	63861	82073	89749	104108	108901
Woking	21368	28969	31548	35809	47643	67507	75956	81358
<b>Surrey</b>	<b>325456</b>	<b>393270</b>	<b>422787</b>	<b>506800</b>	<b>750122</b>	<b>905530</b>	<b>1002252</b>	<b>999393</b>
Adur	11927	14469	16754	21579	38073	47802	55034	58032
Arun	29988	34637	43439	48462	73464	84162	104583	119206
Chichester	46563	50625	51636	56860	72600	78578	91200	97617
Crawley	3598	3780	8238	8875	11167	54722	68647	73081
Horsham	38245	43693	41920	44163	58447	67050	85639	100647
Mid Sussex	37247	41260	42729	45685	59923	79392	100143	118311
Worthing	24298	32216	37094	46499	69357	80348	88401	91668
<b>West Sussex</b>	<b>191868</b>	<b>220682</b>	<b>241811</b>	<b>272124</b>	<b>383032</b>	<b>492051</b>	<b>593646</b>	<b>658562</b>
<b>South East</b>	<b>10428928</b>	<b>11612439</b>	<b>12170796</b>	<b>13348917</b>	<b>14876702</b>	<b>15993116</b>	<b>16930630</b>	<b>16723955</b>
Bath	70429	73901	73371	73771	81605	83598	84787	79965
Bristol	345945	364916	384474	406392	442777	437538	426774	387977
Kingswood	26589	28540	29902	32073	45725	67061	77925	84045
Northavon	35774	35179	35593	39184	60153	71533	104494	118804
Wansdyke	34037	38950	39008	39173	51069	60151	70980	76322
Woodspring	56119	61047	72109	73305	93237	109069	140932	162295
<b>Avon</b>	<b>568894</b>	<b>602535</b>	<b>634456</b>	<b>663900</b>	<b>774567</b>	<b>828953</b>	<b>905890</b>	<b>909408</b>
Caradon	51426	50174	50806	47690	52837	48508	54145	67894
Carrick	55495	54903	53447	55315	61239	63448	70057	76188
Kerrrier	64485	64918	60849	59708	63187	64699	74779	83009
North Cornwall	46887	48992	48791	49266	56034	52379	56489	66189
Penwith	55825	56094	51623	49641	52069	49813	51332	55431
Restormel	46124	50921	53439	54607	58908	62143	72440	79167
<b>Cornwall</b>	<b>320242</b>	<b>326001</b>	<b>318956</b>	<b>316228</b>	<b>344274</b>	<b>340990</b>	<b>379242</b>	<b>430506</b>
East Devon	57947	62248	63815	68102	79487	84226	97215	106320
Exeter	60881	65894	65874	72719	81884	88598	95729	95621

LOCAL AUTH. NAME	1901	1911	1921	1931	1951	1961	1971	1981
-----	----	----	----	----	----	----	----	----
Mid Devon	46371	44927	42329	42769	45618	47154	52325	58057
North Devon	55975	57188	61044	57253	63503	62804	70495	78728
Plymouth	208916	224396	227041	228933	226678	230406	239452	243895
South Hams	43639	45626	45198	47012	55354	55515	59898	67861
Teignbridge	57420	59837	62375	65374	75971	79744	90016	95665
Torbay	51334	59270	63147	74034	88311	96293	109257	115582
Torrridge	42821	42803	41809	39989	41103	40504	44693	47275
West Devon	36892	37513	36985	36782	38712	37455	39324	42996
<b>Devon</b>	<b>662196</b>	<b>699703</b>	<b>709614</b>	<b>732968</b>	<b>796621</b>	<b>822699</b>	<b>898404</b>	<b>952000</b>
Bournemouth	62372	82136	95394	116429	144435	154207	153854	144803
Christchurch	7317	8835	9781	12710	22232	28680	34291	37708
North Dorset	34395	33642	31401	30408	37205	36050	42333	46479
Poole	28673	40442	45535	59822	82597	92022	107146	118922
Purbeck	16630	18179	24222	24385	28512	31990	36676	40414
West Dorset	60938	62725	61076	61064	67083	68269	74052	78337
Weymouth and Portland	39845	44432	41972	41156	48066	52525	54663	57176
Wimborne	18548	20291	20698	22823	28860	35975	51381	68151
<b>Dorset</b>	<b>268720</b>	<b>310685</b>	<b>330077</b>	<b>368796</b>	<b>458990</b>	<b>499721</b>	<b>554394</b>	<b>591990</b>
Cheltenham	54355	54586	53906	55306	68916	80183	84247	84014
Cotswold	51788	53393	50429	49935	63808	61235	62680	68382
Forest of Dene	54247	55335	57896	57483	61452	62770	65888	72651
Gloucester	57668	60613	60857	63292	74437	82874	90046	92133
Stroud	57569	58264	59553	58910	74466	80125	90445	101356
Tewkesbury	29790	31438	30485	30798	47620	59066	73818	80815
<b>Gloucestershire</b>	<b>305418</b>	<b>313629</b>	<b>313127</b>	<b>315721</b>	<b>390698</b>	<b>426254</b>	<b>467126</b>	<b>499351</b>
Mendip	62306	62605	61284	60887	65770	69781	79312	87030
Sedgemoor	47309	49828	49933	50873	62024	69243	80972	89051
Taunton Deane	54260	56018	55077	56970	69555	73169	81986	86025
West Somerset	22212	23402	24881	26125	28313	28768	29753	32299
Yeovil	82119	84965	83164	86351	99824	104503	114332	130583
<b>Somerset</b>	<b>268205</b>	<b>276820</b>	<b>274337</b>	<b>281204</b>	<b>325484</b>	<b>345462</b>	<b>386356</b>	<b>424988</b>
Kennet	47101	49724	47015	47984	57581	54773	64487	63333
North Wiltshire	55097	54759	52096	53350	82502	86171	94995	102492
Salisbury	60560	65457	69869	72293	89543	91558	101105	100929
Thamesdown	59319	65925	70780	77883	90570	119451	139352	152112
West Wiltshire	48960	50584	51927	51685	66470	70997	86808	99301
<b>Wiltshire</b>	<b>271038</b>	<b>286449</b>	<b>291687</b>	<b>303193</b>	<b>386666</b>	<b>422950</b>	<b>486747</b>	<b>518167</b>
<b>South West</b>	<b>2664713</b>	<b>2815822</b>	<b>2872254</b>	<b>2982010</b>	<b>3477300</b>	<b>3687029</b>	<b>4078159</b>	<b>4326410</b>

LOCAL AUTH. NAME	1901	1911	1921	1931	1951	1961	1971	1981
Bromsgrove	23440	25446	30692	35842	52412	64615	77149	88004
Hereford	21841	23135	23525	24404	32501	40434	46503	47652
Leominster	38637	37557	35959	34796	35498	33240	33224	37196
Malvern Hills	64684	65098	63923	61137	69342	70464	77052	81875
Redditch	19261	21482	22534	22673	29222	34252	40839	66593
South Herefordshire	38856	39199	38683	37709	43661	42623	44364	47511
Worcester	51066	52569	51819	53704	62364	66240	73807	74790
Wychavon	46326	49787	52173	52057	64120	69613	82002	95123
Wyre Forest	45921	45985	45836	49285	63857	70406	85061	91474
Hereford and Worcester	350035	360255	365146	371608	452977	491887	560001	630218
Bridgnorth	33576	33883	31429	31316	41379	42601	47700	50259
North Shropshire	38198	40010	39139	39089	46790	45213	47114	50114
Oswestry	24549	25689	26335	26491	31376	29741	30264	30679
Shrewsbury and Atcham	51798	53834	55228	57205	67962	72885	82395	87218
South Shropshire	36419	36132	35863	34718	34068	32594	32391	33815
The Wrekin	55242	56758	55067	55336	68424	74708	97238	123525
Shropshire	239783	246307	243062	244156	289999	297742	337102	375610
Cannock Chase	33435	38468	42722	45828	54044	60301	79290	84526
East Staffordshire	75722	74038	74696	74871	81315	86857	94423	94862
Lichfield	33885	37040	36775	38103	49862	51833	80360	88454
Newcastle-under-Lyme	75482	82515	84944	88994	104577	114636	119990	117922
South Staffordshire	22874	25501	28568	32524	43290	62101	82794	96493
Stafford	52711	56881	61085	61936	83856	92911	111154	117555
Staffordshire Moorlands	49864	54239	57004	61403	74163	78046	90183	95842
Stoke-on-trent	242761	266342	273624	283131	279867	277251	265258	252351
Tamworth	16675	19082	20720	20257	23180	25429	40285	64315
Staffordshire	603407	654110	680142	707049	794154	849365	963737	1012320
North Warwickshire	24431	28897	31836	33787	37729	43120	58119	59808
Nuneaton	34073	48805	58247	65438	79866	90178	107604	113521
Rugby	38071	45931	52427	55192	67897	75187	83620	86120
Stratford-on-Avon	54414	55853	55699	57659	71857	80972	94523	100431
Warwick	54772	56771	61479	65135	81834	97296	111566	113740
Warwickshire	205759	236257	259688	277210	339185	386752	455450	473620
Birmingham	777964	864718	947597	1034020	1160062	1182092	1098085	1006908
Coventry	83217	123736	155756	181420	264616	316024	336387	314124
Dudley	163946	174249	185921	199144	230131	253108	294029	299351
Sandwell	232118	263168	286608	304416	341295	338380	330284	307389
Solihull	21913	26865	29504	42333	94435	136172	191811	198287
Walsall	148188	158817	169593	181035	214899	245697	273456	266123
Wolverhampton	159365	168357	179933	200717	241133	260422	269236	252447

LOCAL AUTH. NAME	1901	1911	1921	1931	1951	1961	1971	1981
West Midlands (County)	1586709	1779913	1954909	2143088	2546568	2731892	2793288	2644634
West Midlands (Region)	2985693	3276842	3502947	3743111	4422883	4757638	5109578	5136402
Beverley	36678	40682	41600	46426	72330	81399	101349	105698
Boothferry	49328	54290	53230	53802	54269	53982	55178	60290
Cleethorpes	16217	28506	36434	38611	41341	49249	66768	68241
East Yorkshire	48273	50039	58218	54152	62986	63563	65503	74997
Glanford	26591	31912	39295	41050	43931	46316	57517	66761
Grimsby	65027	78325	86475	93207	95717	97978	95541	92147
Holderness	19730	21811	26132	26345	31290	33267	39956	45877
Kingston-upon-Hull	241736	279734	291420	314288	299594	303984	285971	268302
Scunthorpe	18207	24411	27399	33758	54291	67347	70908	66353
Humberside	521787	609708	660205	701640	755753	797083	838692	847666
Craven	44169	45895	45966	45616	46034	44939	46469	47653
Hambleton	47062	48780	51100	50090	56920	58878	67187	74153
Harrogate	77901	86358	91292	93647	108590	115245	127527	139736
Richmondshire	28515	28508	29199	38641	50113	39760	42557	42531
Ryedale	50033	51807	50804	52072	58780	65369	72619	84113
Scarborough	76614	76308	88871	81883	90289	88920	97337	101425
Selby	37503	41443	46237	47472	52706	53634	68695	77212
York	86602	91758	91185	96431	109523	108511	104799	99787
North Yorkshire	448396	470855	494655	505853	572952	575255	627191	666610
Barnsley	142296	181556	187885	205944	218385	222693	225514	224906
Doncaster	81110	113280	149596	216410	245396	267872	281035	288801
Rotherham	106783	140043	161481	178207	205364	226869	243110	251336
Sheffield	474381	528337	568964	572199	583703	585865	572853	536770
South Yorkshire	804571	963215	1067926	1172759	1252847	1303300	1322514	1301813
Bradford	422238	436217	434857	446771	449588	452672	461693	457677
Calderdale	228058	221640	216689	214023	208122	200588	195240	191292
Kirkstiles	319472	348033	353452	354409	353507	352297	369354	371780
Leeds	584129	612521	621086	652191	696858	714038	738997	704974
Wakefield	192892	233650	249602	271425	277471	285841	302357	311787
West Yorkshire	1746791	1852059	1875695	1938820	1985546	2005434	2067642	2037510
Yorkshire and Humberside	3521545	3895837	4098481	4319072	4567098	4681072	4856039	4853599

LOCAL AUTH. NAME -----	1901 ----	1911 ----	1921 ----	1931 ----	1951 ----	1961 ----	1971 ----	1981 ----
Alyn and Deeside	24789	31154	35372	38890	48751	51426	65398	72003
Colwyn	23643	27761	34835	34417	38110	38676	45189	48639
Delyn	35521	38191	39885	42829	51283	50756	56881	65140
Glyndwr	37006	37760	37936	37457	39250	38087	37819	40329
Rhuddlan	16017	17927	25667	25849	37605	42044	47524	52338
Wrexham Maelor	76754	85782	88968	89494	98950	101306	105767	111724
<b>Clwyd</b>	<b>213728</b>	<b>238575</b>	<b>262862</b>	<b>268937</b>	<b>313946</b>	<b>322296</b>	<b>358581</b>	<b>390173</b>
Carmarthen	48997	49682	50160	49394	50119	50159	49429	51733
Ceredigion	61078	59880	60881	55184	53278	53648	54882	57372
Dinefwr	33280	42625	45065	45110	41440	38825	36195	36717
Llanelli	53051	68102	79848	84596	80475	79024	76938	75422
Preseli	49156	51686	53185	53886	57059	59621	61130	69323
South Pembrokeshire	38738	38273	38793	33320	33847	34503	37838	39410
<b>Dyfed</b>	<b>284300</b>	<b>310245</b>	<b>327932</b>	<b>321490</b>	<b>316218</b>	<b>315780</b>	<b>316412</b>	<b>329977</b>
Blaenau Gwent	84114	115363	127611	110273	98547	94418	85603	79573
Islwyn	30833	53812	71212	72057	66444	65896	65949	64769
Monmouth	40434	42251	47166	44324	47509	53905	64344	71511
Newport	77208	96325	106882	111812	122443	128449	136822	133698
Torfaen	52941	67754	73645	70635	69756	81035	88423	90133
<b>Gwent</b>	<b>285530</b>	<b>375505</b>	<b>426517</b>	<b>409101</b>	<b>404701</b>	<b>423705</b>	<b>441141</b>	<b>439684</b>
Aberconwy	37615	39934	51785	45974	47851	48532	50878	52503
Arfon	61285	58558	52275	52245	53575	51719	52481	52284
Dwyfor	31476	30842	30711	29123	29099	27478	25902	26285
Meirionnydd	43592	40309	40019	38382	37204	34334	31508	32056
Ynys Mon (Anglesey)	50478	50804	51612	48934	50596	51654	59765	67340
<b>Gwynedd</b>	<b>224446</b>	<b>220449</b>	<b>226403</b>	<b>214659</b>	<b>218324</b>	<b>213719</b>	<b>220535</b>	<b>230468</b>
Cynon Valley	78491	97827	102752	91354	76187	72561	69427	67188
Merthyr Tydfil	75811	90448	90093	80323	69158	67129	63287	60528
Ogwr	60783	86901	103492	98939	104172	111024	123593	129773
Rhondda	115101	154175	163567	142049	111538	100419	88953	81725
Rhymney Valley	47183	88233	105475	102010	95162	95969	101960	105525
Taff-Ely	49112	67394	79890	76036	73866	72550	84624	93127
<b>Mid Glamorgan</b>	<b>426478</b>	<b>584978</b>	<b>645266</b>	<b>590708</b>	<b>530080</b>	<b>519650</b>	<b>531847</b>	<b>537866</b>
Brecknock	39300	42548	43595	42016	41340	39495	37764	40691
Montgomery	55020	53232	51284	48500	46118	44230	43124	48201
Radnor	23400	22676	23538	21350	20121	18536	18284	21575
<b>Powys</b>	<b>117720</b>	<b>118457</b>	<b>118418</b>	<b>111866</b>	<b>107578</b>	<b>102260</b>	<b>99173</b>	<b>110467</b>

LOCAL AUTH. NAME -----	1901 ----	1911 ----	1921 ----	1931 ----	1951 ----	1961 ----	1971 ----	1981 ----
Cardiff	183577	209810	236226	245566	267577	290263	287646	273856
Vale of Glamorgan	48855	58495	67373	70787	83718	90005	102623	110777
South Glamorgan	232432	268306	303600	316354	351294	380267	390269	384633
Afan	26958	39728	50833	50915	53301	60642	59347	54663
Lliw Valley	35008	51811	59428	63229	58409	55652	56283	59745
Neath	44136	60576	68038	71566	72146	70122	67792	66587
Swansea	122139	152290	167178	174507	172677	179930	189824	186199
West Glamorgan	228242	304406	345476	360217	356534	366346	373246	367194
Wales	2012876	2420921	2656474	2593332	2598675	2644023	2731204	2790462
Berwickshire	25550	24504	23560	22114	20662	18337	16995	18092
Etrick and Lauderdale	37770	38643	35730	35314	34403	33509	32429	31594
Roxburgh	41510	39996	38154	39136	38761	36221	35374	35180
Tweeddale	15196	15283	15495	15192	15317	14166	13681	14382
Borders	120027	118425	112938	111755	109142	102232	98477	99248
Clackmannan	32608	32103	32895	32258	37939	41932	46093	47806
Falkirk	96476	110010	109754	115623	125910	132255	140501	144437
Stirling	56306	62475	64974	63650	69028	70432	76433	80835
Central	185389	204589	207624	211532	232876	244620	263028	273078
Annandale and Eskdale	33420	33345	35197	33664	33624	35347	34592	35338
Nithsdale	43476	43712	49577	50608	55317	56031	56465	56493
Stewartry	31437	30594	25166	24558	24813	23299	22208	23138
Wigtown	36307	35539	33368	31889	34251	31757	29922	30109
Dumfries and Galway	144639	143190	143308	140719	148005	146434	143187	145078
Dumfries	76033	98569	114196	102190	118465	120003	120530	122232
Kirkcaldy	84858	104785	113609	113419	125405	139617	144955	141861
NE. Fife	57946	64378	65121	60759	62908	61072	61645	62387
Fife	218837	267733	292925	276368	306778	320692	327131	326480
Aberdeen (City)	174146	184028	178700	187326	204101	208054	211960	203612
Banff and Buchan	90309	92194	88014	81839	80307	75100	72854	81446
Gordon	63819	61283	57603	57057	53658	48907	45008	62157
Kinross and Deeside	41720	39781	40138	35296	36655	33303	33117	47112
Moray	78428	77841	74177	71548	76375	74989	75693	81269
Grampian	448421	455127	438633	433066	451094	440351	438630	470596

LOCAL AUTH. NAME	1901	1911	1921	1931	1951	1961	1971	1981
Badenock and Strathspey	10459	10313	11016	9806	9563	9121	9309	12355
Caithness	37953	35845	31859	28683	24970	29416	29610	27383
Inverness	40404	39201	38266	40120	45686	45848	49760	56557
Lochaber	17021	16290	13765	15499	15613	15910	19193	20539
Nairn	9377	9423	8862	8368	8785	8451	11051	10139
Ross and Cromarty	42026	42885	39068	34442	33653	32698	34855	47305
Skye and Lochalish	17502	16234	14028	12699	11023	10062	9725	11327
Sutherland	18818	17844	15467	14230	12407	12290	11971	14425
Highland	193559	188035	172328	163846	161702	163796	175473	200030
East Lothian	53300	62252	67232	66773	72802	74431	77406	80187
Edinburgh	406368	415380	432045	449943	478340	484250	476629	436271
Mid Lothian	52847	58033	45444	48029	57481	65683	79744	81661
West Lothian	67206	79649	77946	74525	82254	85799	111843	137373
Lothian	579722	615316	622668	639271	690878	710163	745623	735892
Argyll and Bute	80327	76434	91536	70798	72340	66046	65141	68786
Bearsden and Milngavie	7278	7141	7050	8302	20250	26024	35873	39322
Clydebank	30199	46459	55465	55984	52669	57867	58805	51825
Clydesdale	51759	62787	54431	51123	54415	54625	53524	57361
Cumbarnauld and Kilsyth	14988	15292	15277	15433	16826	18663	45632	61707
Cumnock and Doon Valley	41592	41463	41725	40760	46668	52832	48779	45509
Cunninghame	84371	85507	110073	92366	106199	111259	125878	138265
Dumbarton	57884	61385	65557	60260	65990	70477	78806	78041
East Kilbride	25325	30611	24450	22935	14145	40899	74159	82499
Eastwood	19997	26787	12673	17225	38175	43825	49857	53547
Glasgow (City)	940087	976418	1123563	1166779	1174552	1139970	982203	763162
Hamilton	87354	106288	91571	88219	95566	96876	104731	107987
Inverclyde	97900	108534	119615	114115	113734	112458	109365	99966
Kilmarnock and Loudoun	65703	66575	68390	69189	73826	78945	81010	82149
Kyle and Carrick	71433	77937	93223	89547	101175	105076	110476	114463
Monklands	76405	87907	84885	86009	97203	106465	109646	110455
Motherwell	141559	177544	155158	151075	154470	159976	161435	150015
Renfrew	141421	163884	154018	156612	172673	182538	202901	205884
Strathkelvin	43439	50896	41176	43491	52681	59241	77302	86884
Strathclyde	2079017	2269840	2409832	2400223	2523548	2584068	2575514	2397827
Angus	100927	95017	90845	83520	87221	85109	84152	92841
Dundee (City)	185503	188721	182511	188933	189943	195523	197466	180064
Perth and Kinross	113026	114370	115078	111264	119031	117187	115987	118624
Tayside	399455	398109	388433	383716	396194	397820	397605	391529
Orkney	28699	25897	24111	22077	21255	18747	17077	18906
Shetland	28166	27911	25521	21421	19352	17812	17327	26716

<u>LOCAL AUTH. NAME</u>	<u>1901</u>	<u>1911</u>	<u>1921</u>	<u>1931</u>	<u>1951</u>	<u>1961</u>	<u>1971</u>	<u>1981</u>
Western Isles	47647	47606	44177	38966	35591	32609	29891	31766
Islands	104512	101414	93809	82484	76198	69168	64295	77388
Scotland	4473578	4761778	4882498	4842980	5096415	5179344	5228963	5117146

APPENDIX B: Distribution of errors

The tables on the following pages list the differences between the county population totals, from 1901 to 1971, as given in the 1974 census volumes by OPCS, and those as calculated by the author. Data for each county are presented as a 4 by 8 matrix, and the row and column headings are as follows:

Row 1: OPCS county population total.

Row 2: The author's county population total.

Row 3: Difference (OPCS total - author's total).

Row 4: Difference as a percentage of OPCS total.

Col. 1: 1901

Col. 2: 1911

Col. 3: 1921

Col. 4: 1931

Col. 5: 1939

Col. 6: 1951

Col. 7: 1961

Col. 8: 1971

There are no 1939 National Registration figures for Scotland. There is also no difference between the OPCS data and the author's county population total for any of the Island areas.

101 CAMBRIDGESHIRE

283256	302267	308583	328913	346840	390892	436555	505667
282763	301804	310121	330467	377626	390892	436555	505667
493	463	-1538	-1554	-30785	0	0	0
0,174	0,153	-0,498	-0,472	-8,876	0,0	0,0	0,0

102 NORFOLK

476020	498008	503853	505005	505780	551518	565915	625792
477872	500589	506049	506853	536211	553360	566843	625716
-1852	-2581	-2196	-1848	-30431	-1842	-928	76
-0,389	-0,518	-0,436	-0,366	-6,017	-0,334	-0,164	0,012

103 SUFFOLK

370636	391270	397127	398019	402200	439105	467130	538018
368836	389158	394931	396171	433506	437263	466202	538094
1800	2112	2196	1848	-31306	1842	928	-76
0,486	0,540	0,553	0,464	-7,784	0,419	0,199	-0,014

201 DERBYSHIRE

593433	675194	705503	746050	764088	810037	846807	886611
580857	659024	693322	733756	758150	810037	846807	886611
12576	16170	12181	12294	5938	0	0	0
2,119	2,395	1,727	1,648	0,777	0,0	0,0	0,0

202 LEICESTERSHIRE

451190	496899	512807	559036	586860	651687	706153	799571
455887	495525	512807	559036	600844	651686	706153	799571
-4688	1374	0	0	-13984	1	0	0
-1,039	0,277	0,0	0,0	-2,383	0,000	0,0	0,0

203 LINCOLNSHIRE

360844	387573	399203	404669	413109	456613	468657	503497
360738	387383	399203	404669	421233	456613	468657	503497
106	190	0	0	-8124	0	0	0
0,029	0,049	0,0	0,0	-1,967	0,0	0,0	0,0

204 NORTHAMPTONSHIRE

294506	303797	302404	309474	318540	359721	398057	468623
294424	303716	302311	309377	359629	359571	397883	468385
82	81	93	97	-41089	150	174	238
0,028	0,027	0,031	0,031	-12,899	0,042	0,044	0,051

205 NOTTINGHAMSHIRE

514107	603761	640749	712330	756593	840174	900989	974573
514009	603630	640708	711827	750871	840179	902024	975354
98	131	41	503	5722	-5	-1035	-781
0,019	0,022	0,006	0,071	0,756	-0,001	-0,115	-0,080

301 CLEVELAND

338188	378572	417964	438531	439877	473269	526497	567766
341853	382060	418887	439170	425008	473409	526925	567662
-3665	-3488	-923	-639	14869	-140	-428	104
-1,084	-0,921	-0,221	-0,146	3,380	-0,030	-0,081	0,018

302 CUMBRIA

435656	436394	461036	437270	428572	464398	470130	476133
435135	436393	461037	437270	473534	464398	470130	476133
521	1	-1	0	-44962	0	0	0
0,120	0,000	-0,000	0,0	-10,491	0,0	0,0	0,0

303 DURHAM

452483	557098	603129	597030	577601	596889	605263	607174
449003	556077	602085	597100	586483	598030	605153	606266
2580	1021	1044	-70	-8882	-1141	110	908
0,570	0,183	0,173	-0,012	-1,538	-0,191	0,018	0,150

304 NORTHUMBERLAND

219271	251693	273993	264481	262717	272644	274315	279556
215215	248701	270870	263528	278218	271683	275655	279583
4056	2992	3123	953	-15501	961	-1340	-27
1,850	1,189	1,140	0,360	-5,900	0,352	-0,488	-0,010

305 TYNE AND WEAR

069317	1105314	1181151	1200944	1188433	1201391	1243848	1211694
077776	1110863	1184877	1201356	1073565	1200801	1242206	1212107
-8459	-5549	-3726	-412	114868	590	1642	-413
-0,873	-0,502	-0,315	-0,034	9,665	0,049	0,132	-0,034

401 CHESHIRE

484508	527272	544622	577950	608517	687162	729779	866556
479514	523663	542855	576626	627055	684240	729781	867335
4994	3609	1767	1324	-18538	2913	-2	-779
1,031	0,684	0,324	0,229	-3,046	0,424	-0,000	-0,090

402 GREATER MANCHESTER							
2403868	2638269	2673801	2727104	2714226	2716204	2719913	2728997
2407574	2640940	2675816	2729000	2562014	2718729	2721759	2728851
-3706	-2671	-2015	-1896	152212	-2525	-1846	146
-0,154	-0,101	-0,075	-0,070	5,608	-0,093	-0,068	0,005

403 LANCASHIRE							
1025372	1115274	1160916	1170814	1171082	1238599	1261188	1344762
1015516	1105137	1150355	1159137	1221552	1231066	1258382	1344071
9856	10137	10561	11677	-50470	7533	2806	691
0,961	0,909	0,910	0,997	-4,310	0,608	0,222	0,051

404 MERSEYSIDE							
1233332	1377879	1497157	1586575	1607213	1662733	1718186	1656545
1243651	1388271	1506751	1597008	1531336	1670882	1719581	1657591
-10319	-10392	-9594	-10433	75877	8149	-1395	-1046
-0,837	-0,754	-0,641	-0,658	4,721	-0,490	-0,081	-0,063

501 BEDFORDSHIRE							
173864	196850	208835	222958	268196	313434	382706	464277
172508	195463	207362	221483	297843	313434	382706	464277
1356	1387	1473	1475	-29647	0	0	0
0,780	0,705	0,705	0,662	-11,054	0,0	0,0	0,0

502 BERKSHIRE							
235625	258995	274780	301801	334407	402054	510096	624612
235022	258749	273988	301882	399777	403380	506668	624574
603	246	792	81	-65370	-1326	3428	38
0,256	0,095	0,288	-0,027	-19,548	-0,330	0,672	0,006

503 BUCKINGHAMSHIRE							
172541	190627	203211	225742	247415	303583	377863	476222
171702	189315	202635	224311	286341	301241	380677	476354
839	1312	576	1431	-38926	2342	-2814	-132
0,486	0,688	0,283	0,634	-15,733	0,771	-0,745	-0,028

504 EAST SUSSEX							
410387	442696	486186	492735	514921	554307	586230	647460
410861	442615	486186	497735	621857	554307	586230	647460
-474	81	0	0	-106936	0	0	0
-0,116	0,018	0,0	0,0	-20,767	0,0	0,0	0,0

## 505 ESSEX

405334	488473	554215	643375	718850	839177	1103616	1358028
403153	486242	552571	641414	745726	839176	1103616	1358028
2181	2231	1644	1961	-26876	1	0	0
0,538	0,457	0,297	0,305	-3,739	0,000	0,0	0,0

## 506 GLC

6506889	7160441	7386755	8110358	8615050	8196807	7992443	7452346
6508228	7161684	7378470	8108542	8617972	8196807	7992443	7452346
-1339	-1243	8285	1816	-2922	0	0	0
-0,021	-0,017	0,112	0,022	-0,034	0,0	0,0	0,0

## 507 HAMPSHIRE

650507	774974	808335	884872	959219	1029612	1150653	1373008
646469	770335	805442	881876	871172	1026332	1149944	1372887
4038	4639	2893	2993	88047	3280	709	121
0,621	0,599	0,358	0,338	9,179	0,319	0,062	0,009

## 508 HERTFORDSHIRE

241797	290373	310860	373313	455780	561445	787850	924632
242772	290511	310905	373370	525594	561828	788378	925177
-975	-138	-45	-57	-69814	-383	-528	-545
-0,403	-0,048	-0,014	-0,015	-15,317	-0,068	-0,067	-0,059

## 509 ISLE OF WIGHT

82418	88186	94666	88454	85800	95625	95752	109512
82418	88186	94666	88454	93377	95625	95752	109512
0	0	0	0	-7577	0	0	0
0,0	0,0	0,0	0,0	-8,831	0,0	0,0	0,0

## 510 KENT

806488	868927	938112	958701	1014520	1091153	1198564	1399463
806752	867493	938848	959655	1057966	1091153	1198564	1399463
-264	1434	-736	-954	-43446	0	0	0
-0,033	0,165	-0,078	-0,100	-4,282	0,0	0,0	0,0

## 511 OXFORDSHIRE

225754	237945	240243	262684	293782	356351	409762	505172
227197	239504	241771	264171	330139	357367	410375	505079
-1443	-1559	-1528	-1487	-36357	-1016	-613	93
-0,639	-0,655	-0,636	-0,566	-12,375	-0,285	-0,150	0,018

512 SURREY							
325456	393274	422787	506800	627700	750122	905530	1002252
324464	392921	424383	508763	701767	749605	905659	1002209
992	349	-1596	-1963	-74067	517	-129	43
0,305	0,089	-0,377	-0,387	-11,800	0,069	-0,014	0,004
513 WEST SUSSEX							
191868	220682	241811	272124	327279	383032	492051	593646
191712	221142	242132	272494	419064	383549	491921	593689
156	-460	-321	-370	-91785	-517	130	-43
0,081	-0,208	-0,133	-0,136	-28,045	-0,135	0,026	-0,007
601 AVON							
568894	602535	634456	663900	701644	774567	828953	905890
574743	608239	640379	669148	753169	778082	831950	905190
-5849	-5704	-5923	-5248	-51525	-3515	-2997	700
-1,028	-0,947	-0,934	-0,790	-7,343	-0,454	-0,362	0,077
602 CORNWALL							
320242	326001	318956	316228	310100	344274	340990	379242
321544	327262	320077	317295	328231	344274	340990	379242
-1302	-1261	-1121	-1067	-18131	0	0	0
-0,407	-0,387	-0,351	-0,337	-5,847	0,0	0,0	0,0
603 DEVON							
662196	699703	709614	732968	746790	796621	822699	898404
661166	698512	708267	731657	780244	796621	822699	898404
1030	1191	1347	1311	-33454	0	0	0
0,156	0,170	0,190	0,179	-4,480	0,0	0,0	0,0
604 DORSET							
268720	310685	330077	368796	394151	458990	499721	554394
272550	314922	332967	371789	448474	462270	500430	554516
-3830	-4237	-2890	-2993	-54323	-3280	-709	-122
-1,425	-1,364	-0,876	-0,812	-13,782	-0,715	-0,142	-0,022
605 GLOUCESTERSHIRE							
305418	313629	313127	315721	321906	390698	426254	467126
302375	310833	310150	313450	353824	389325	424543	468240
3043	2796	2977	2271	-31918	1373	1711	-1114
0,996	0,891	0,951	0,719	-9,915	0,351	0,401	-0,238

606 SOMERSET							
268205	276820	274337	281204	281780	325484	345462	386356
265056	273818	271724	278541	326512	323901	344819	386710
3149	3002	2613	2663	-44732	1583	643	-354
1,174	1,084	0,952	0,947	-15,875	0,486	0,186	-0,092
607 WILTSHIRE							
271038	286449	291687	303193	310500	386666	422950	486747
270867	286274	291707	303250	346987	386666	422950	486747
171	175	-20	-57	-36487	0	0	0
0,063	0,061	-0,007	-0,019	-11,751	0,0	0,0	0,0
701 HEREFORD AND WORCESTER							
350035	360255	365146	371608	382932	452977	491887	560001
345901	355155	363317	369438	431416	452977	491887	560001
4134	5100	1829	2170	-48484	0	0	0
1,181	1,416	0,501	0,584	-12,661	0,0	0,0	0,0
702 SALOP							
239783	246307	243062	244156	244900	289999	297742	337102
239326	245820	243307	244389	266967	289999	297742	337102
457	487	-245	-233	-22067	0	0	0
0,191	0,198	-0,101	-0,095	-9,011	0,0	0,0	0,0
703 STAFFORDSHIRE							
603407	654110	680142	707049	728172	794154	849365	963737
604228	655897	681608	708433	738093	794154	849365	963737
-821	-1787	-1526	-1384	-9921	0	0	0
-0,136	-0,273	-0,224	-0,196	-1,362	0,0	0,0	0,0
704 WARICKSHIRE							
205759	236257	259688	277210	295696	339185	386752	455450
194756	224182	247533	262866	292752	328258	378313	455292
11003	12075	12155	14344	2944	10927	8439	158
5,348	5,111	4,681	5,174	0,996	3,222	2,182	0,035
705 WEST MIDLANDS							
1586709	1779913	1954909	2143088	2334810	2546568	2731892	2793288
1599829	1792986	1966483	2157344	2277492	2557134	2739805	2792420
-13120	-13073	-11574	-14256	57318	-10566	-7913	868
-0,827	-0,734	-0,592	-0,665	2,455	-0,415	-0,290	0,031

801 HUMBERSIDE							
521787	609708	660205	701640	733882	755753	797083	838692
521364	609143	659843	701666	691515	755425	796878	838682
423	565	362	-26	42367	328	205	10
0,081	0,093	0,055	-0,004	5,773	0,043	0,026	0,001
802 NORTH YORKSHIRE							
448396	470855	494655	505853	519713	572952	575255	627191
435719	459585	489470	501892	551889	568891	572232	627054
12677	11270	5185	3961	-32176	4061	3023	137
2,827	2,394	1,048	0,783	-6,191	0,700	0,526	0,022
803 SOUTH YORKSHIRE							
804571	963215	1067926	1172759	1192493	1252847	1303300	1322514
828678	990248	1083986	1189224	1182115	1253908	1302359	1322596
-24107	-27033	-16060	-16465	10378	-1061	941	-82
-2,996	-2,807	-1,504	-1,404	0,870	-0,085	0,072	-0,006
804 WEST YORKSHIRE							
1746791	1852059	1875695	1938820	1940164	1985546	2005434	2067642
1755504	1859636	1880101	1942634	1894405	1989081	2008556	2067421
-8713	-7577	-4406	-3814	45759	-3535	-3122	221
-0,499	-0,409	-0,235	-0,197	2,359	-0,178	-0,156	0,011
901 CLWYD							
213728	238575	262862	268937	277100	313946	322296	358581
212980	237855	262203	268462	305189	313625	322043	358602
748	720	659	475	-28080	321	253	-21
0,350	0,302	0,251	0,177	-10,133	0,102	0,078	-0,006
902 DYFED							
284300	310245	327932	321490	306900	316218	315780	316412
284300	310242	327932	321490	318239	316218	315780	316412
0	3	0	0	-11339	0	0	0
0,0	0,001	0,0	0,0	-3,695	0,0	0,0	0,0
903 GWENT							
285530	375505	426517	409101	379564	404701	423705	441141
290825	379885	426871	410256	390324	406299	424818	441056
-5295	-4380	-354	-1155	-10760	-1598	-1113	85
-1,854	-1,166	-0,083	-0,282	-2,835	-0,395	-0,263	0,019

904 GWYNEDD

224446	220449	226403	214659	207021	218324	213719	220535
225086	221067	227062	215133	233947	218645	213972	220514
-640	-618	-659	-474	-26926	-321	-253	21
-0,285	-0,280	-0,291	-0,221	-13,006	-0,147	-0,118	0,010

905 MID GLAMORGAN

426478	584978	645266	590708	526188	530080	519650	531847
418285	576614	640169	586493	527640	529189	519352	532090
8193	8364	5097	4215	-1452	891	298	-243
1,921	1,430	0,790	0,714	-0,276	0,168	0,057	-0,046

906 POWYS

117720	118457	118418	111866	102557	107578	102260	99173
117363	118198	118354	111785	109753	107195	102066	99157
357	259	64	81	-7196	383	194	16
0,303	0,219	0,054	0,072	-7,017	0,356	0,190	0,016

907 SOUTH GLAMORGAN

232432	268306	303600	316354	314821	351294	380267	390269
235664	272619	308741	319765	327274	350927	379678	390347
-3232	-4313	-5141	-3411	-12453	367	589	-78
-1,391	-1,607	-1,693	-1,078	-3,956	0,104	0,155	-0,020

908 WEST GLAMORGAN

228242	304406	345476	360217	351040	356534	366346	373246
228321	304421	345249	360081	355173	356749	366538	373362
79	-15	227	136	-4133	-215	-192	-116
-0,035	-0,005	0,066	0,038	-1,177	-0,060	-0,052	-0,031

1001 BORDERS

120027	118425	112938	111755	108478	109142	102232	98477
119506	118326	112287	111192	0	108803	102193	98459
521	99	651	563	108478	339	39	18
0,434	0,084	0,576	0,504	100,000	0,311	0,038	0,018

1002 CENTRAL

185389	204589	207624	211532	219909	232876	244620	263028
185498	203454	208529	212353	0	233402	244631	262949
-109	1135	-905	-821	219909	-526	-11	79
-0,059	0,555	-0,436	-0,388	100,000	-0,226	-0,004	0,030

1003 DUMFRIES AND GALWAY

144639	143190	143308	140719	141193	148005	146434	143187
144668	143190	143308	140719	0	148005	146434	143187
-29	0	0	0	141193	0	0	0
-0,020	0,0	0,0	0,0	100,000	0,0	0,0	0,0

1004 FIFE

218837	267733	292925	276368	285206	306778	320692	327131
218753	267630	292857	276314	0	306778	320692	327130
84	103	68	54	285206	0	0	1
0,038	0,038	0,023	0,020	100,000	0,0	0,0	0,000

1005 GRAMPIAN

448421	455127	438633	433066	443419	451094	440351	438630
453987	458817	441517	438396	0	453586	441993	438487
-5566	-3690	-2884	-5330	443419	-2492	-1642	143
-1,241	-0,811	-0,657	-1,231	100,000	-0,552	-0,373	0,033

1006 HIGHLAND

193559	188035	172328	163846	160810	161702	163796	175473
192872	187203	171755	163255	0	161172	163572	175474
687	832	573	591	160810	530	224	-1
0,355	0,442	0,333	0,361	100,000	0,328	0,137	-0,001

1007 LOTHIAN

579722	615316	622668	639271	677870	690878	710163	745623
582077	618170	623319	639834	0	691217	710203	745642
-2355	-2854	-651	-563	677870	-339	-40	-19
-0,406	-0,464	-0,105	-0,088	100,000	-0,049	-0,006	-0,003

1008 STRATHCLYDE

2079017	2269840	2409832	2400223	2504706	2523548	2584068	2575514
2068818	2284403	2410349	2400469	0	2524051	2584385	2575523
10199	-14563	-517	-246	2504706	-503	-317	9
0,491	-0,642	-0,021	-0,010	100,000	-0,020	-0,012	-0,000

1009 TAYSIDE

399455	398109	388433	383716	385060	396194	397820	397605
398853	397514	388044	383213	0	395874	397717	397674
602	595	389	503	385060	320	103	-69
0,151	0,149	0,100	0,131	100,000	0,001	0,026	-0,017

APPENDIX C: Sources of data

This appendix lists the principal sources of data used for this research.

- Population data presented in tables 4.2, 4.3 and 4.5 were taken from the original (1971) and reaggregated (1974/5) Census volumes. These figures represent original OPCS data. Data presented in tables 5.2, 5.4 and 5.5 represent the results of calculations to derive a data set, described in chapter 4; population data used in these calculations originate from the County Census Reports, for the Censuses of 1911 to 1971 inclusive.

The same volumes were used for information on changes in boundaries of local government areas, as used in chapter 4 and presented in tables 4.1 and 4.4, and for the dates of 20th century censuses presented in table 5.3.

- 1939 population totals were obtained from a volume entitled 'National Registration of England and Wales, 1939' and published by the GRO in 1940.
- The mid-year estimates of population used in chapter 4 and table 4.6 were obtained from the OPCS Monitor, Series PP. Mid-year estimates quoted in table 8.1 were obtained from the

relevant volumes of the Registrar General's Statistical Review of England and Wales, and the Annual Report of the Registrar General for Scotland.

The above sources can all be found in Durham or in Newcastle University Library.

APPENDIX D: Description of a GIMMS command file

In order to give some idea of a GIMMS production run for a frame in the film, each command in figure 7.2 (page 301) is now briefly described.

\*PLOTARM: this sets up the plotting parameters, directing output to a PDF (c.f. the screen).

\*SYSPARM: sets up system parameters, here switching off data listings.

\*TEXTARM: sets up text parameters, selecting alphabet 16 (triplex serif).

\*PLOTPROG: enters the plotting program.

\*GIMMSFILE: opens up locational data files on units 10 and 11, and sets the scaling factor at 0.005.

\*DATAFILE: command to read thematic data, 11 variables / zone. (Variable 1 is in fact the area code to which the remaining ten density values refer.)

\$continue with ... : MTS command to switch to reading thematic data file.

\*LEVELS: sets up two classes for the output map.

\*INTERVALS: class intervals for ten variables.

\*SYMBOLISM: sets up the shading for each area - blank for the first, and for the second, lines 0.08 mm apart, at 0 degrees

(i.e. horizontal), in line type 0 (solid) and pen 3 (red).

\*JOINSCAN: requests joining of shading lines (see above) with intermediate storage on unit 7.

\*LEGEND: sets up parameters for the key.

\*OUTLINE: switches off boundary drawing.

\*NEWMAP: defines frame area (30 \* 52 cm with a surrounding frame).

\*SYSPARM: here, this command causes file 7 (used in \*JOINSCAN) to be rewound to the beginning for use with a new map.

\*SCISSOR: positions the inset plotting area for the Shetlands (in cms).

\*ORIGIN: sets up the co-ordinate system for the Shetlands in the above inset.

\*DRAWMAP: draws the outline of the file on unit 11 (the Shetlands).

\*SCISSOR: resets the plotting area to the default (as specified by \*NEWMAP).

\*ORIGIN: resets the co-ordinate system - the National Grid co-ordinates X=0 and Y=620 are placed at X=0, Y=0 on the plotting area.

\*DRAWMAP: draws the external outline only of the file on unit 10 (Great Britain).

\*TEXT: positions and sets the size of text, also centring it. All text is in upper case unless preceded by the modifier @L.

\*MAP: shades variable 2 according to the above options.

The above is the sequence of commands for one map: all those from \*NEWMAP to \*MAP are repeated a further nine times to generate the ten maps in one run. The remaining commands (\*END and \*STOP) then cause the exit from the plotting program and the final exit from GIMMS itself, outputting the plot buffers to the PDF.

