

Durham E-Theses

Effect of application of carcinogenic substances on the epidermal cell populations of mouse skin

Ian Richard Major

How to cite:

Major, Ian Richard (1971) Effect of application of carcinogenic substances on the epidermal cell populations of mouse skin. Masters thesis, Durham University.

Use policy

The full-text may be used and/or reproduced, and given to third parties in any format or medium, without prior permission or charge, for personal research or study, educational, or not-for-profit purposes provided that:

- a full bibliographic reference is made to the original source
- a <https://etheses.durham.ac.uk/id/eprint/10244/> is made to the metadata record in Durham E-Theses
- the full-text is not changed in any way

The full-text must not be sold in any format or medium without the formal permission of the copyright holders.

Please consult the [full Durham E-Theses policy](#) for further details.

EFFECT OF APPLICATION OF CARCINOGENIC
SUBSTANCES ON THE EPIDERMAL CELL
POPULATIONS OF MOUSE SKIN

Ian Richard Major
University College

Master of Science Thesis
1971

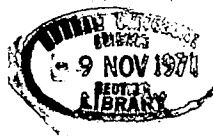

CONTENTS

	<u>Page Number</u>
Acknowledgements	5
List of Plates	7
Summary	9
Chapter 1 - Introduction	11
Cancer	11
Carcinogenic Agents	14
Tobacco Smoke	16
Epidermal Thickening	18
Screening Tests	22
Chapter 2 - Materials and Methods	23
Animals	23
Chemicals	24
Tobacco Smoke Condensate	25
Shaving	30
Administration	31
Sampling	31
Fixing	31
Washing	32
Processing	33
Embedding	33
Microtomy	33
Staining	34
Chapter 3 - The Histology of Mouse Skin	35
Epidermis	35
Dermis	36
Hairs	37

Chapter 4 - The extent and duration of changes in width of the epidermis induced by topical application of condensed tobacco smoke compared with those brought about by other substances	39
Measurement of Epidermal Thickness	40
Single Exposure - acetone and water	41
tobacco smoke condensate ..	42
3.4 - Benzpyrene	46
Phenol and Toluene ..	46
Ethanol and Dimethylsulphoxide	48
Repeated Exposure Tobacco Smoke Condensate	48
Chapter 5 - The effect of various substances on the rate of cellular division of the epidermal cell population in the area of topical application	55
Stathmokinetic Agents	56
Proliferation Rate	57
Mitotic Duration	57
Cell Counting	58
Control Results	58
3.4 - Benzpyrene	61
Tobacco Smoke Condensate	61
Neutral Fraction	61
Efficiency of Arrest	61
Chapter 6 - The effect of a carcinogenic and a non- carcinogenic polycyclic aromatic hydrocarbon on the epidermis com- pared with that of a non-carcinogenic irritant.	64
20 - Methylcholanthrene	65
1.2 - Benzanthracene	66
Allyl-iso-thiocyanate	66

Chapter 6 - (continued)

Epidermal Thickness	66
Cell Population	67
Mitotic Index	67
Cell Size	68
Control Results	69
Diurnal Rhythm	70

Chapter 7 - An attempt to correlate early epidermal changes with the two stage mechanism of carcinogenesis by examining the effect of a single painting of urethane and Compound A₁

Tumour Regression	103
Initiation	104
Transformation	105
Cocarcinogenic Promotion	105
Urethane	107
Compound A ₁	115
Urethane followed by Compound A ₁	116

Chapter 8 - An investigation of the response patterns of several more examples of each class of activity and the subsequent development of a screening test, for carcinogens and co-carcinogens

9.10 - Dimethyl 1.2 - Benzanthrane	126
3.4 - Benzpyrene	127
1.2.5.6. - Dibenzanthracene	128

Chapter 8 - (continued)

1.2.7.8. - Dibenzanthracene	129
1.2.3.4. - Dibenzanthracene	130
20 - Methylcholanthrene	131
Tricycloquinazoline	131
Acridine	132
Cantharidin	133
Croton Oil	133
Analysis and Interpretation of Results	134

Chapter 9 - The application of the short term test to fractions of tobacco smoke condensate in an attempt to predict their biological activity in long term skin painting experiments

143

Results on Fractions

147

Chapter 10 - General Discussion

155

Practical Considerations

155

Irritation Versus Promotion

156

Tobacco Smoke Condensate Mode of Action ..

157

Value of the Screening Test

158

Theoretical Considerations

158

References

Plates

ACKNOWLEDGEMENTS

The work reported here was carried out on behalf of the Tobacco Research Council as part of my duties whilst employed at the Harrogate Laboratories from 1965-1970, and I express my gratitude to the Council and the United Kingdom Tobacco Companies for permission to present it in this form. The suggestion to submit this work as a thesis was made by Professor F. Dickens, Director of the Laboratories from 1966-1969. Professor D. Barker of the Zoology Department arranged for my admission as an external candidate for the degree of Master of Science and the appointment of my internal Teacher Consultant. Dr. K. Bowler agreed to act in this capacity and Dr. R. F. Davies acted as my external supervisor. To all these I express my gratitude for their interest and encouragement which largely sustained by confidence and enthusiasm.

I thank Dr. J. K. Whitehead and Dr. K. Rothwell for permission to include details of the smoking procedures, condensate collections and fractionation schemes. I am particularly grateful to Dr. Whitehead, Principal of the Harrogate Laboratories and former Head of the Chemistry Department, who demonstrated his interest and confidence in the work by affording me the opportunity to submit the condensate fractions to the screening test.

I am indebted to Miss M. V. Chapman who supervised the animal husbandry and assisted me in carrying out the experiments, willingly giving of her free time at weekends, evenings and several times throughout the night. It is also a pleasure to acknowledge Mrs. A. Tennant who

processed all the skins, prepared the sections for measuring and counting and assisted with the photography of the plates and figures.

I am grateful to Mr. P. N. Lee who showed such a personal interest in the work, advised me on the best statistical analyses and devised a computer programme so that the results in the later chapters could be analysed without carrying out tedious calculations.

My thanks are due to all those other members of the T.R.C. staff who were always ready to advise and help with specific problems. Finally I express my appreciation to the typists for the draft and final copies of this thesis.

LIST OF PLATES

1. NORMAL EPIDERMIS - Section through the epidermis of the shaved area of skin from an untreated albino mouse.
2. HYPERTROPHY - Section of epidermis taken from a mouse two days after painting with 20 - methylcholanthrene. The number of cells is similar to that found in untreated mice but the epidermal thickness is increased by cellular hypertrophy.
3. HYPERPLASIA - Section of epidermis taken from a mouse four days after painting with 20 - metholcholanthrene showing hyperplasia of the squamous cells with very little hypertrophy.
4. HYPERPLASIA AND HYPERTROPHY - Section of epidermis taken from a mouse two days after painting with compound A₁ showing extensive hyperplasia and hypertrophy.

Plates 1-4 are at the same magnification = x 2,300

5. Section of skin stained to show the basement membrane marking the boundary between the epidermis and dermis. Periodic acid-Schiff, gallocyanin and light green.
6. Whole skin preparation from the shaved area of an untreated mouse. Toluidine blue.
7. Whole skin preparation from a mouse treated with smoke condensate (100 mg. in 0.3 ml.) showing engorgement of blood vessels and increased number of mast cells and inflammatory bodies.
8. High power of mast cells in a whole skin preparation from an untreated mouse (Toluidine blue stained metachromatically).

9. Disruption of mast cells with release of granules into the dermis of a mouse treated with smoke condensate.
10. Technique used to shave an area on the back of the mice.
11. Application of test substances by Jencons repette
12. Excision of skin from the painted area.
13. Skin samples removed from the painted area.
14. Measuring scale and square inscribed on the eyepiece graticule superimposed on a section of epidermis to illustrate how the measurements were made.
15. Section of epidermis from a mouse painted with an irritant and injected with colchicine three hours before sampling to show arrested metaphase nuclei.
16. Section of epidermis from a mouse injected with colchicine three hours before sampling. The presence of anaphase and telophase nuclei indicates that some cellular division is still in progress and the arrest of metaphase figures is not fully efficient.

SUMMARY

Application of certain substances to the shaved skin of mice results in an increase in thickness of the epidermis. This phenomenon was examined to determine its nature and whether any distinction could be drawn between the mechanism by which it is produced by carcinogens and non-carcinogenic irritants. Such a distinction might form the basis of a short term bio-assay which would be invaluable in helping to identify carcinogens, the presence of which is suspected in many substances consumed by the human population.

Increase in epidermal thickness was shown not to be proportional to carcinogenic potency, but evidence is presented which suggests that the powerful carcinogens induce thickening by the same specific mechanism and this is related to their promoting properties. The response of the epidermis after treatment with irritant chemicals appears to be non-specific and depends upon the nature of the applied material. Simple quantitative measurements of cell population, size of cells and thickness of the epidermis were made over the first five days of exposure to a single application of many active substances and response patterns were recognised which could be correlated with initiation, promotion and total carcinogenicity. Initiating activity appears to be associated with an interference in the progress of cells through the cell cycle and although this results in a measurable reduction in total cell population, there does not appear to be a direct effect upon mitosis.

The development of a short term cancer test provided a rapid method of examining the biological activity of condensed tobacco smoke which induces tumours to arise in mouse skin after prolonged and persistent application. The response patterns following a single application of fractions of the condensate, isolated by physico - chemical separations indicated that some of these contained co-carcinogenic constituents, although there was little evidence of initiating activity.

CHAPTER 1

INTRODUCTION

CANCER

Benign and malignant tumours
Nomenclature of tumours
Chemical induction
Skin tumours

CARCINOGENIC AGENTS

Latent period and tumour incidence
Promotion and initiation

TOBACCO SMOKE

EPIDERMAL THICKENING

Contributing parameters
Irritant and carcinogenic

SCREENING TESTS

CANCER

A tumour was defined by Willis (1948) as "an abnormal mass of tissue, the growth of which exceeds and is unco-ordinated with that of normal tissue, and persists in the same excessive manner after cessation of the stimuli which evoked the change". Biological organisms have a high degree of organisation which is attained through growth and differentiation based on a cellular structure. The growth of an organism is achieved by cellular division which is strictly controlled and limited. Differentiation of cells leads to the formation of



specialised tissues and organs within the organism. Tumour growth is unique in that it does not follow this purposeful organisation which characterises a living organism. Tumour cells are derived from normal cells but have in some way escaped the control of the forces which govern normal cell growth. Some authorities believe that tumour cells have acquired a new characteristic which enables them to overcome the intrinsic governing organisational forces of the body, while other authorities believe that it is the systemic control itself which has been lost and all cells would behave like tumour cells if this influence were removed.

In benign tumours the cells are properly differentiated to show the characteristic features of the tissue of origin. They grow by expansion and the rate of growth is quite slow and may stop quite suddenly and be followed by a partial or complete regression. Malignant tumours generally bear little resemblance to the original tissue and are characterised by this lack of differentiation. Growth is very rapid and new tissue infiltrates into the surrounding normal tissue. The malignant cells have the power to enter the blood and lymphatic systems and pass to other localities in the body and develop into secondary tumours or metastases. Benign tumours may develop into malignant tumours but it is not known whether all malignant tumours pass through an intermediate benign phase.

Tumours are named after the tissue from which they originated

and according to whether they are malignant or benign. Tumours of the non-glandular epithelia are termed papilloma if benign and carcinoma if malignant. The latter are also given a prefix to indicate the type of epithelium from which they are derived. In this way, a malignant tumour arising from the epidermis is known as a squamous cell carcinoma. In experimentally induced skin cancer, this is normally preceded by the formation of a papilloma, which is simply an outgrowth of the epidermis, topped by a conical mass of keratin. Malignant tumours of supporting tissue such as connective tissue, bone, cartilage muscle or fat are named sarcoma. Glandular tumours are termed adenoma if benign and adenocarcinoma if malignant. There exist also tumours involving the cells of lymph and blood e.g. lymphosarcoma and tumours of nerve tissue.

All these tumours can be produced experimentally in animals by chemical carcinogens. The least complex and most easily observed action of carcinogens is the production of tumours at the site of application, e.g. when painted on the skin of the experimental animal or injected subcutaneously. The process becomes more complex when tumours arise at distant sites after, for example, intravenous injection.

Yamagiva and Ichikawa (1918) were the first workers to succeed in inducing papillomata in the skin of rabbits by persistent topical application of coal tar. Prior to the formation of a papilloma, there is an increase in thickness of the epidermis and epithelial hyperplasia and the formation of papillary processes extending upwards between the enlarged

and cystic hair follicles, which are filled with keratin. Later, at the beginning of the malignant stage, a typical proliferation occurs at the base of the epidermis and cell processes break through the basement membrane and into the underlying connective tissue. Cell growth spreads invasively downwards through the connective tissue and the panniculus carnosus muscle. The tumour cells themselves, forming a large solid mass, show some resemblance to the epidermal structure with early squamous cells at the periphery and keratinised cells on the outside, sometimes with pearls of keratin. Very malignant skin tumours, however, may assume a trabecular arrangement and consist only of irregular polygonal cells. The tumour is supplied and supported by a stroma of fibrous connective tissue containing blood vessels. If growth is so rapid as to outstrip the vascular supply, haemorrhages and necrosis may occur in the centre of the tumour mass.

CARCINOGENIC AGENTS

Carcinogenic substances are those which significantly increase the yield of malignant neoplasms in an animal population. They can broadly be separated into three main classes: ionising radiation, viruses and chemical compounds. This work is only concerned with the latter class. The vast majority of chemical carcinogens can be classified further according to their chemical or biological activity e.g. polycyclic aromatic hydrocarbons, azo dyes, biological alkylating agents, aromatic amines, inorganic substances and hormones. Very often they only induce tumours at particular sites within the animal's

body and they may be active in particular species e.g. the skin of the rat is relatively resistant to the polycyclic hydrocarbons, whereas that of the mouse is relatively susceptible.

Some of the polycyclic hydrocarbons have been found to be very potent carcinogens on mouse skin and are capable of producing a high tumour incidence after only a single painting. Many chemical carcinogens, however, must be painted persistantly over and over again before tumours arise. In both cases there is a period of time between the first exposure to a group of mice and the appearance of the first tumour. The duration of this period appears to be associated with the identity and dose level of the carcinogen and also with the strain of mice employed. This period of time which elapses between the application of the carcinogen and the first appearance of a tumour for any given dosage is known as the latent period. The tumour incidence is the proportion of animals bearing tumours out of the whole number of animals treated with a given dosage. It is important to extend the experiment until no more tumours are being produced in the exposed group and that the number of animals is sufficiently large to give a reliable estimate. In general, a carcinogen which produces a high tumour incidence also has a short latent period and vice versa, but there are some exceptions. These two criteria are usually used in combination when trying to compare the relative potency of carcinogens.

In addition to pure chemical carcinogens, some substances can enhance tumour incidence and shorten the latent period when applied together with, or shortly after the carcinogen although they are not

capable of giving rise to tumours on their own. These substances are known as cocarcinogens or promoting agents and the phenomenon is termed promotion. Very often when the dose level of a pure carcinogen is gradually reduced, the latent period is extended until the tumour incidence falls to zero. Dose levels below this threshold are known as initiating dose levels and the carcinogen is then known as a cocarcinogenic initiator since the subsequent application of a promoting agent restores the carcinogenic activity and results in the induction of tumours.

TOBACCO SMOKE:

The work at the Tobacco Research Council Laboratories is concerned with the relationship between tobacco smoking and health. Cancer research forms a large part of the programme because human epidemiological studies (Best Josie and Walker, 1960; Doll and Hill, 1954:1956) suggest that the risk of developing lung cancer, particularly squamous cell carcinoma, may be increased by cigarette smoking. It would seem logical to assume that the development of this type of cancer must proceed through a stage in which the normal columnar cells of the lung undergo a metaplastic transformation into squamous cells. Such a transformation has been demonstrated in experimental animals subjected to inhalation treatment with tobacco smoke. It has also been known for some time that condensed tobacco smoke applied persistantly to shaved mouse skin is capable of inducing epithelial tumours (Wynder and Hoffmann, 1953). The relevance of these observations to human lung cancer may be rather obscure, but similar attempts to demonstrate

a carcinogenic activity of tobacco smoke on lung tissue of experimental animals have met with very limited success (Stewart and Herrold, 1962; Peacock and Peacock, 1966; Harris and Negroni, 1967) and topical application provides the most satisfactory bio-assay system. The disadvantages of this system are:

- (a) the time required (two years-three years);
- (b) its relevance to human lung tissue;
- (c) its inability to demonstrate a recognisable change with cocarcinogenic agents which are incapable of inducing tumours on their own, but which may, nevertheless, be potentially very potent.

Tobacco smoke condensate contains many thousands of constituents and it seems likely that its total carcinogenic activity results from the separate cocarcinogenicity of several of these constituents. Attempts are being made to identify these substances on the assumption that they fall into distinctive chemically related groups. Progress in splitting tobacco smoke condensate into fractions using physico-chemical separations is good (Whitehead and Rothwell, 1969), but determination of the biological activity of these fractions is held up by the length of time taken in carrying out each long term skin painting experiment. During the course of the routine pathological screening of skin samples taken from the treated area of mice which had been removed from some of the earlier long term experiments, a thickening of the epidermis was noted. Tests were carried out and it was shown that even single applications of tobacco smoke condensate produced an increased epidermal thickness within a few hours.

EPIDERMAL THICKENING

Increase in width of the epidermis is an integral part of the initial response of mouse skin to treatment with irritants and carcinogens and it is a parameter which can be measured very readily. Chapter 4 is devoted to a description of the preliminary work carried out on this single parameter. It can be analysed into three distinctive components, any of which could change and contribute to its increase:

- (a) the cell population;
 - (b) the size of the constituent cells;
 - (c) the size of the intercellular spaces.
- (a) Hyperplasia would result if the normal process of cell loss was reduced or if the rate of cell production was increased. A reduction in the rate of cell loss would suggest some interference with the process of differentiation or maturation of the squamous cells. An increase in the rate of cell production could result from either a regenerative attempt to compensate for cells which have been irreversibly damaged or a stimulative shock which forces cells to enter cellular division prematurely. Such a condition could be demonstrated by a stathmokinetic investigation and this is discussed in Chapter 5.
- (b) Hypertrophy most probably results from an increased fluid uptake by the cells. The reason for this remains a matter of conjecture but would be most likely to result from

damage to cell membranes or the reticulo endothelium.

Investigations of changes in cell size are described in Chapters 6 and 7.

- (c) The reason for an increase in the size of the intercellular spaces is again very uncertain, but it may be associated with changes in the adhesive properties of the cell membrane. It is also difficult to visualise a technique by which such a parameter could be measured. Setala, Merenmies, Stjernvall, Nyholm and Aho (1960) used the electron microscope to examine changes after treatment with Tween 60 and concluded that there was an increase in the intercellular space, and this contributed to less than one fifth of the greatest increase in epidermal thickness.

Treatment of mouse skin with a carcinogen induces a hyperplastic response in the epidermis within a few hours, but hyperplasia is not a specific response to carcinogenic administration and is frequently observed in association with lesions caused by physical or chemical damage. Wolbach (1936), Orr (1938) and Page (1938) were unable to distinguish hyperplasia induced by carcinogens from that induced by non-carcinogenic irritants. The latter type forms part of a regenerative process which occurs after a part of that tissue has been destroyed, and these workers considered the carcinogen-induced hyperplasia to be part of such a regenerative process.

Pullinger (1940:1941) described the changes which occur each day

in the epidermal cell population, drawing attention to the increase in volume of nuclei and cells, the disturbance in the incidence of mitotic division and the discrepancy between the comparatively small proportion of degenerative cells and the subsequent strong hyperplasia. She believed that these, and other characteristics could be used to distinguish a carcinogen from a non-carcinogen. Glucksmann (1945) showed that the hyperplasia produced by benzpyrene (BP) is not related to any noteworthy degenerative effect and that the duration of the hyperplastic activity cannot be correlated with tissue damage. Reller and Cooper (1944) reported a rise in mitotic activity which starts within forty-eight hours of application and is progressive for the first thirty-seven days. Evensen (1961) also observed an increase in the mitotic count and suggested that this was due to either an increase in the number of cells going into mitosis, or to prolonging of the division time. Cramer and Stowell (1942) preferred to regard the initial thickening of the epidermis as cellular differentiation rather than hyperplasia, since they were unable to correlate the increase in the number of cells with a proportional increase in mitotic activity, even after treatment with colchicine. They reported a true hyperplasia occurring much later, about three to four weeks after a single application of 20 - methylcholanthrene (MC), but this only occurred in a proportion of the mice which they termed the 'susceptible' animals. In these the hyperplasia often develops into a tumour without further application of the carcinogen. They also demonstrated that the dose of

20 - methylcholanthrene necessary to induce skin cancer diminishes as the interval between successive applications of the carcinogen is prolonged. They believe that a carcinogen might react with living tissue in two ways which conflict with each other; both stimulating and inhibiting mitotic activity. Prolonging the interval between successive applications would diminish the toxic inhibiting action and enable the proliferating action to proceed to a point above which it becomes uncontrolled.

Exhaustive studies were carried out (Iversen, 1960a:1960b:1961: Iversen, Aandahl and Elgjo, 1965; Iversen and Bjerknes, 1963; Iversen and Evensen, 1962; Iversen and Iversen, 1964; Elgjo, 1963:1966; Evensen, 1962:1964; Evensen and Iversen, 1962) into the rate of cell renewal and cell loss in the epidermis of hairless mice after carcinogen and irritant treatment. These indicate that DNA - synthesis and cellular division are immediately inhibited on carcinogen treatment and this inhibition lasts for several hours. It is accompanied by loss of damaged cells from the surface. This loss is then made good by a rapid rate of cell renewal and within a short time, a transient hyperplasia is evident. These workers have suggested that this is a regenerative process. The epidermis then returns to normal except for the mitotic index, which may be persistently higher for the next ten weeks. Proliferation is at a normal level and the increased index is due to a longer duration of cellular division.

This report describes the investigation carried out to determine

whether these early epidermal changes could be correlated with the carcinogenic or cocarcinogenic activity of the substances painted on the skin and, if this was so, whether a short term bio-assay system could be designed to screen the activity of fractions of tobacco smoke condensate.

SCREENING TESTS

Screening tests based on epidermal hyperplasia, incidence of sebaceous glands and inflammatory changes, have been reported in the literature (Lazar, Libermann, Chouroulinkov and Guerin, 1963; Riley, 1966), but their reliability is doubtful and they are restricted in that they are only useful for general comparative work. It would seem likely that many of the changes upon which they are based are associated with the promoting activity of carcinogens and that several aspects of these changes undoubtedly result from treatment with non-carcinogenic irritants as well.

CHAPTER 2

MATERIALS and METHODS

MATERIALS

Animals
Chemicals
Tobacco Smoke Condensate
Preparation
Fractionation

METHODS

Shaving
Administration
Sampling
Fixing
Washing
Processing
Embedding
Microtomy
Staining

MATERIALS

Animals - The mice were supplied by Dr. D. G. Davey of the Pharmaceuticals Division, Imperial Chemical Industries Limited from the specific pathogen free albino colony maintained near Macclesfield in Cheshire. The females are more easily maintained because they have less tendency to fight with each other than the males and can, therefore, be caged together. The long term skin painting experiments carried out in these laboratories are, therefore, confined to the testing of female mice. The early part of this work, investigating changes in thickness, was also carried out on female mice. When the work was extended to include observations on cellular division male

mice were used, because the oestrous cycle in female mice is known to have an effect upon the mitotic index (Bullough, 1946). The mice were isolated in an air-conditioned room which was maintained at a constant temperature (20°C-21°C) and they were provided with Oxoid breeding diet pellets and water ad libitum. The males were housed separately in galvanised iron boxes on sterile sawdust. In order to avoid disturbing the animals during the course of an experiment, the boxes were not changed and the room was only visited for essential maintenance and to obtain skin samples at the appropriate time. They were supplied when three months old and then allowed to become accustomed to their surroundings for two weeks.

Chemicals - These were obtained from the following sources: Professor E. Hecker, Biochemisches Institut, Heidelberg (Cocarcinogen A₁); Chester Beatty Research Institute (Croton Oil); University of Nottingham (Tricycloquinazoline); British Drug Houses Limited (Urethane, 1.2 - benzanthracene, phenol, toluene, ethyl alcohol, dimethyl sulphoxide); Fluka A. G., Buchs, Switzerland (20 - methylcholanthrene, 1.2.5.6 - dibenzanthracene); Koch Light Laboratories (9.10 - dimethyl 1.2 - benzanthracene, 1.2.3.4 - dibenzanthracene, 3.4 - benzpyrene, acridine); Middletons Limited, Stockton on Tees (allyl-iso-thiocyanate); B. Newton Maine Limited (1.2.7.8 - dibenzanthracene); C.I. B.A. Laboratories (Colcemid).

The 1.2 - benzanthracene was purified by repeated recrystallization from ethanol. The other agents were used without additional purification.

Tobacco Smoke Condensate (TSC) - Preparation - This was carried out by the Chemistry Department at the Tobacco Research Council Laboratories according to the method described by Day (1967):

Plain cigarettes (length 70 mm., circumference 25.3 mm., average weight 1.125 g.) were specially manufactured from a composite blend of flue-cured tobacco representing the major plain cigarette brands smoked in the United Kingdom, packed in batches of fifty in vacuum-sealed tins and stored at 4°C. before use.

The automatic smoking machine used operates by connecting each of twenty-four cigarettes, secured in holders situated round a revolving disc, in turn to a source of vacuum the unlighted end of each cigarette being open to atmosphere between puffs. Cigarettes were lighted by an electrically heated coil. When individual cigarettes had reached an estimated butt length of 20 mm., the butts were removed and replaced with fresh cigarettes.

Automatic smoking constants were chosen to simulate the manner used by the average cigarette smoker in the United Kingdom (Bentley and Burgan, 1961):

Puff volume 25 ml.; Puff duration two seconds
Puff interval one minute; butt length 20 mm.

Cigarette smoke was collected in four glass traps connected in series, cooled in acetone/crushed solid carbon dioxide. Traps 3 and 4 each contained glass helices (100 g., 4 mm. diam. single turn). On completion of smoking, traps were allowed to attain room temperature, condensed smoke was washed from the traps and connecting tubes with

acetone (about 900 ml.), the washings filtered through glass wool and an aliquot of the combined filtrate taken to check non-volatile whole smoke yield by determination of nicotine. The average yield of nicotine was 1.61 mg./cigarette, range 1.30-1.91 mg./cigarette.

Fractionation - This was carried out as described by Whitehead and Rothwell (1969):

Fractions B and C - A suspension of TSC (20 g.) in acetone (25 ml.) was poured, in small quantities, into distilled water (300 ml.) with shaking after each addition. Rapid cooling and vigorous shaking caused the insoluble material to adhere to the flask and a clear yellow filtrate was obtained by filtration through a wet, double, fluted filter (Whatman No. 1). The insoluble residue was treated similarly twice using 12 ml. of acetone and 150 ml. of distilled water for each further treatment.

Fraction B - (yield 52.0% w/w TSC) was recovered by freeze drying the combined aqueous extracts and Fraction C (yield 45.3% w/w TSC) was recovered by dissolving the insoluble materials in acetone and evaporating the combined solutions to constant weight, under reduced pressure, at not more than 10°C.

Fractions D and E - The bulked aqueous extracts were continuously extracted with ether for twenty-four hours. The ethereal extract after drying (anhydrous MgSO₄) was evaporated below 10°C. to leave Fraction E. Yield 26.0% w/w TSC.

Fraction D was recovered by freeze drying the residual aqueous solution. Yield 26.4% w/w TSC.

Fractions F and G - Fraction C (from 20 g. TSC) in methanol (180 ml.) was vigorously shaken with cyclohexane (200 ml.) and after dilution with water (20 ml.) the shaking was continued. The phases were separated by centrifugation. Four further extractions of the lower phase with cyclohexane (200 ml.) were carried out. Fraction G was recovered from the combined cyclohexane extracts (yield 24.5% w/w TSC) and Fraction F from the methanol by evaporation to constant weight as above (yield 15.1% w/w TSC).

Fractions F and G - Fraction C (from 20 g. TSC) in methanol (180 ml.) was vigorously shaken with cyclohexane (200 ml.) and after dilution with water (20 ml.) the shaking was continued. The phases were separated by centrifugation. Four further extractions of the lower phase with cyclohexane (200 ml.) were carried out. Fraction G was recovered from the combined cyclohexane extracts (yield (24.5% w/w TSC) and Fraction F from the methanol by evaporation to constant weight as above (yield 15.1% w/w TSC).

Fractions H and J - Fraction G (from 20 g. of TSC) dispersed in methanol (100 ml.) was shaken with urea (20 g.). The mixture was cooled from 25°C. to 0°C. ($\frac{1}{2}$ °C. per hour) and kept at 0°C. overnight. After the mixture had attained room temperature, aqueous saturated urea solution (12 ml.) was added and the whole was extracted with cyclohexane (6 x 100 ml.) centrifuging when necessary to break any emulsions formed. The cyclohexane solution was dried (MgSO₄) and the solvent at 10°C. under reduced pressure to leave Fraction J (urea non-adductable). Yield 17.9% w/w TSC.

The urea adduct and aqueous methanolic residue were mixed with hot water (600 ml., 80°C.) and the mixture formed was extracted, after cooling, with benzene (100 ml. aliquots) until colourless. The bulked benzene washings were dried (MgSO₄) and the solvent removed, as before, to leave Fraction H. Yield 5.3% w/w TSC.

Fractions K and L - Fraction J (from 20 g. TSC) was dissolved in cyclohexane (30 ml.) and the solution was extracted with DMSO (4 x 20 ml.). Each aliquot of DMSO was then washed successively with cyclohexane (3 x 10 ml.). Solvents were equilibrated before use. The combined upper phases were washed with water (2 x 50 ml.), dried and evaporated, as above, to give Fraction K. Yield 8.8% w/w TSC. The combined lower phases were diluted with the aqueous washings and distilled water (ca. 800 ml.) and the solution, after saturation with salt, was extracted with benzene (100 ml. aliquots) until colourless. The benzene extract was dried and evaporated to give Fraction L. Yield 5.3% w/w TSC.

Fractions M and N - Fraction L (from 20 g. TSC) dissolved in benzene (200 ml.) was shaken with silica gel (14 g.) (Koch-Light chromatographic grade, 50-100 mesh, deactivated by adjusting the water content to 7.9% w/w). After filtering and washing the gel with benzene (10 ml.), the volume of the filtrate and washings was reduced to 50 ml. under reduced pressure. The above procedure was repeated with a further batch of silica (7 g.). Fraction N was recovered by evaporation of the solvent from the combined benzene solutions and washings. Yield

1.6% w/w TSC. Fraction N was obtained by extraction of the silica gel residues with methanol in a Soxhlet extractor. Yield 3.0% w/w TSC.

Fractions G2a, G1 and G2b - A Quickfit and Quartz Steady State Distribution Machine was modified so that extraction could be carried out simultaneously in each of two 5l tube trains. The solvent pair was made by equilibrating cyclohexane with 9:1 methanol:water, the water being half saturated with AnalaR Sodium Chloride. The work was carried out in a temperature controlled room at 20°C.

Fraction G (35 g.) dissolved in upper phase (175 ml.) was charged in tubes 0 to 6 in each tube train numbered as follows:

delivery of)	(delivery of
upper phase) (+8 to +1) (0 to -6) (-7 to -42)	(lower phase
from machine)	(from machine

The machine was programmed to carry out 614 transfers, delivering 25 ml. of upper phase and 25 ml. of lower phase in opposite directions in the ratio of two upper phase transfers to eleven lower phase transfers. All the upper phase delivered from the machine was collected in a single receiver and the lower phase from transfers 0-319 and from 320-614 in separate receivers. The residues were recovered from the lower phase, after the methanol had been removed, by extraction into cyclohexane which was then washed with water, dried (MgSO_4) and evaporated to constant weight. Upper phase was washed with water, dried (MgSO_4) and the residue recovered by evaporating off the solvent. The sub-fractions collected were made up as follows:

G2A Lower phase ejected during transfers 0-319

This fraction contained all the material within the distribution coefficient range 0-2.50 with a proportion of material from 2.5-2.75 and the yield was 4.9% w/w TSC.

G1 Material remaining in tubes +7 to -42 after 614 transfers and lower phase ejected during transfers 320-614.

This fraction contained all the material within the distribution coefficient range 2.75-6.06 with some material from 2.5-2.75 and from 6.06-6.58. The yield was 2.0% w/w TSC.

G2B The contents of tubes +8 and 9 and the upper phase ejected during transfers 0-614. This fraction contained all the material within the distribution coefficient range 6.58-∞ with some material from 6.06-6.58 and the yield was 14.3% w/w TSC.

Subfraction G1 contains all the unsubstituted polycyclic aromatic hydrocarbons.

Subfraction G2 is made by recombining fractions G2A and G2B and contains no polycyclic aromatic hydrocarbons.

Shaving

About twenty-four hours before treatment, a strip of skin, approximately 2 cms. wide, was shaved along the dorsal midline of the mice from the nape of the neck to the base of the tail. (Plate 10). Great care was taken to avoid damaging the skin and on the rare occasions when this did happen, the mouse was discarded. The clippers were lubricated with sesame oil which is generally regarded as having no promoting properties. The shaving was always started at 10.00 hours G. M. T. to avoid changes which might be associated with a diurnal rhythm. Several technicians worked on each batch of mice and, on average, one person could shave one mouse each minute.

Administration

Painting was carried out at 08.30 hours on the following day when a volume of 0.3 ml. of the test solution was delivered directly from the syringe of a Jencons repette to form a shallow lake bound by the unshaved hair on the edge of the treated area and the solvent was then allowed to evaporate (Plate 11). The mice were removed from their boxes and passed to the person carrying out the dosing procedure.

Skin painting was always performed by the same technician at a rate of about twelve mice every three minutes. The Jencons repettes were checked and recalibrated before each experiment. After painting, the mouse boxes were replaced on the battery and labelled according to the sampling scheme.

Sampling

At specific times which were rigidly adhered to in all cases, the mice were killed by cervical dislocation and a rectangular area of skin, with the longer side at right angles to the dorsal line of the animal and slightly wider than the treated area, was removed from the lower thoracic region of each mouse (Plate 12). The under surface of the skin was applied to thin card to minimise distortion during fixation.

Fixing

Fixation was carried out in Zenker's fluid with 5 per cent glacial acetic acid.

Mercuric chloride	5.0 g.
Potassium dichromate	2.5 g.
Sodium sulphate monohydrate ..	1.0 g.
Distilled water	100 ml.

This stock solution can be stored for long periods and the glacial acetic acid added just before use. The optimum time for fixation was found by trial and error to be about four hours. Sometimes when the skin samples were taken at inconvenient times, such as late in the evening, part of the fixation was carried out in a refrigerator at about 4° C. when the appropriate fixation time was increased sixfold and the samples could then be removed more conveniently from the fixative during the course of the following day.

Washing

During processing the potassium dichromate is gradually reduced to the very insoluble green chromium salts which are impossible to remove and inhibit haematoxylin staining. To avoid this, it is necessary to remove the dichromate by washing with tap water. The dichromate is particularly difficult to remove from mouse skin and it was found necessary to set up a special syphoning arrangement which continually flushed the samples with tap water for seven full days. Before continuing to process the samples they were immersed in distilled water for one hour.

Processing

The following scheme was used:

50% alcohol	two changes over two hours
70% alcoholic iodine	several changes until the following day
70% alcohol	half hour
96% alcohol... .. .	two changes over one and a half hours
Absolute alcohol	Three changes over six hours
Absolute alcohol/chloroform..	the samples were left in absolute alcohol overnight and when they became completely dehydrated they dropped down into the chloroform layer
Xylene	the following morning the samples were carefully transferred to xylene and within ten-twenty minutes they became completely translucent
Paraffin wax at about 56° C. ..	two changes of two and a half hours each

All processing was carried out manually without the aid of an automatic processing machine.

Embedding

The samples were blocked in paraffin wax individually using the Tissue Tek system. This consists of plastic rings which fit into metal boats in which the tissue is embedded. The plastic ring is filled up with wax and fits very conveniently into the microtome chuck.

Microtomy

The blocks were pre-cooled on trays of ice and cut at 5 μ m. on a Jung rotary microtome. Two sections of skin were mounted on each slide and these were selected from different ends of the ribbon. The slides were allowed to dry overnight and then stained the next day.

Staining

Ehrlich's haematoxylin with eosin counterstaining was the normal method of staining.

1. Removal of wax with xylene - five minutes
2. Absolute alcohol - until slides ran clear
3. 70% alcohol - " " " "
4. Distilled water - " " " "
5. Iodine in potassium iodide - three minutes - washed in tap water
6. 5% sodium thiosulphate solution - three minutes - washed in tap water
7. Distilled water - a short rinse
8. Ehrlich's haematoxylin - time depending upon ripeness
9. Washed in two rinses of tap water
10. Acid alcohol to differentiate - washed in tap water
11. Blued in warm tap water - twenty minutes
12. 1% aqueous eosin - five-ten minutes
13. Washed in water until the water remained clear
14. 70% alcohol
15. Absolute alcohol
16. Cleared in xylene and mounted in DPX

CHAPTER 3

THE HISTOLOGY OF MOUSE SKIN

INTRODUCTION

EPIDERMIS

DERMIS

HAIRS

INTRODUCTION

The skin consists of two main layers, the surface epithelium or epidermis which is derived from the ectoderm and the lower dense connective tissue layer, the dermis which is derived from the mesenchyme. In addition, there is often a looser connective tissue layer below the dermis which may consist of much subcutaneous fatty tissue and is sometimes referred to as the hypodermis. The boundary between the epidermis and the dermis is well defined, but it is impossible to draw a sharp histological boundary between the dermis and the subcutaneous layer because the fibres pass between the two layers.

EPIDERMIS

In the normal adult mouse the epidermis consists of two or more layers of nucleated cells. The basal layer is composed of genuine basal cells, together with some spinous cells. The external layers are formed from non-nucleated keratinising cells and between these and the basal layer additional spinous cells and a non-uniform stratum granulosum may sometimes be distinguished.(Plate 1). Its main function is protective; it is very difficult to moisten with water and it

prevents the underlying tissues from drying. The very thin keratin plates on the surface are welded so closely together that they are very hard to isolate, even after prolonged maceration. The epidermis has no vascular system and it is supplied by tissue fluid which penetrates into the inter-cellular spaces of the nucleated cells from the blood capillaries in the underlying connective tissue. Between the epidermis and the dermis there is a basement membrane which stains positively with periodic acid-Schiff (Plate 5).

It requires only one application of a carcinogen to transform this very thin epidermis into several layers, in which the basal layer, stratum spinosum, stratum granulosum and stratum corneum become distinct. There is also a progressive increase in the size of the cells and nuclei. It is very easy to make the mistake of regarding the epidermis as a constant stationary feature, when it should be visualised as a living tissue in a constant state of activity. A proportion of the keratinised cells are continually being lost from the surface and replaced by new cells moving up from the basal layer.

DERMIS

Bundles of collagenous fibres run in various directions of which the main one is always more or less parallel to the surface and these form a dense network which is strengthened by elastic fibres occupying the spaces between collagenous fibres. The connective tissue contains many cells such as fibroblasts, undifferentiated cells, macrophages, lymphoid wandering cells, mast cells, eosinophils, plasma cells and fat cells. Deeper in the dermis, the connective tissue

becomes less tightly packed and areolar connective tissue is more abundant. Sometimes this is differentiated separately as the hypodermis. In female mice this layer is much thicker and the collagenous elastic layer is thinner than it is in male animals. The lower dermal layers are penetrated everywhere by large blood vessels and nerve tracks and contain many nerve endings.

Following carcinogen treatment, the collagenous fibres become swollen and may appear to be fragmented and more widely separated than normal. The capillary vessels become swollen and engorged with blood (Plates 6 and 7) and the lymphatic capillaries also become dilated, suggesting an eodematous condition. Acute inflammation is very evident with an abundance of polymorphonuclear leucocytes. Accumulations of mononuclear cells, fibroblasts and various other cells such as mast cells can be observed. The mast cells become disrupted and in many areas the granules can be seen to be discharged (Plates 8 and 9).

HAIRS

These arise from the epidermis in tubular invaginations of the skin, the walls of which are composed of modified epidermal and dermal tissue. The connective tissue papilla projects into the bottom of the hair follicle deep in the dermis. The root of the hair develops into the hair shaft, the free end of which protrudes beyond the surface of the skin. The hairs are oiled by secretions from the sebaceous glands which are located in the obtuse angle between the follicle and the surface and open into the neck of the follicle. The hairs afford protection against cold, water and general attrition and also play a part in escape responses and sexual display.

After carcinogen treatment, many of the hair follicles may become blocked by the excessive production of keratin around their mouths and pressure atrophy is often evident. It has been shown by fluorescence studies (Simpson and Cramer, 1943) that carcinogenic polycyclic hydrocarbons can penetrate the hair follicles and become localised in the sebaceous glands.

The experiments were always performed when the mice were three and a half months old, since mitotic index is thought to vary with age (Bullough, 1949). In addition, it is known that the activity of the epidermis is associated with the hair cycle since it was shown that hair proliferation has an effect upon the number of cells in the epidermis, the thickness of the dermis and adipose layer and the size of the sebaceous glands (Chase, Montagna and Malone, 1953). The hair cycle is believed to be in the resting phase at this age (Andreasen, 1953).

CHAPTER 4

THE EXTENT AND DURATION OF CHANGES IN WIDTH OF THE EPIDERMIS INDUCED BY TOPICAL APPLICATION OF CONDENSED TOBACCO SMOKE COMPARED WITH THOSE BROUGHT ABOUT BY OTHER SUBSTANCES

INTRODUCTION

METHODS

Measurement of epidermal thickness

RESULTS

Single exposure

Acetone and distilled water (9:1 by volume)

Tobacco smoke condensate

3.4 - Benzpyrene

Phenol and toluene

Ethanol and dimethylsulphoxide

Repeated exposure

Tobacco smoke condensate

DISCUSSION

CONCLUSIONS

INTRODUCTION

This chapter describes the preliminary studies which were undertaken to establish the duration and magnitude of the initial response, using increase in width as a representative characteristic.

The response to single applications of different dose levels of tobacco smoke condensate were compared to determine whether there was a qualitative correlation and, if so, whether it was displayed by changes in magnitude or duration. This was followed by an examination of the effect of repeated applications of the highest dose level. It

seemed unlikely that epidermal thickening would continue to increase indefinitely and such an experiment might provide information on the ways in which the epidermis might make adjustments to deal with a prolonged and persistent insult. In addition, it was important to determine the rate at which the cell population recovered after treatment had been terminated. The behaviour of the epidermis after treatment with tobacco smoke condensate was compared with the response obtained after treatment with two dose levels of a pure carcinogen (3.4 - benzpyrene) and mixtures of tobacco smoke condensate and the same carcinogen.

Experiments were carried out with various organic liquids to see whether they induced any epidermal changes which would prohibit their use as solvents. Finally, the response to single applications of non-carcinogenic irritant substances was investigated.

The main purpose in this series of experiments was to establish the time factors involved in the various changes, i. e. the time between painting and the first increase in thickness, the time before maximum thickness was attained and the duration of the recovery period. The design of future experiments depended very much upon whether the progress of the hyperplastic reaction was the same after treatment with all the different types of test substances and whether single peaks or multiple peaks of activity invariably occurred.

Measurement of Epidermal Thickness

This was measured with a scale on a graticule incorporated in the microscope eyepiece (Plate 14). The measurement was always

made to the nearest division on the scale. Calibration was carried out with a standard stage micrometer on which a millimetre scale was engraved in 0.1 and 0.01 graduations. The eyepiece division was about 1 micrometer using a 100x oil immersion lens and 10x oculars. The measurements were made from the junction between the epidermis and the dermis to the outer extremity of the basophilic keratohyline granules (Plate 1). During processing of the skins, a proportion of the cornified cells on the surface become stripped off the underlying cells and the amount of keratinised material removed in this way varies considerably along the length of the skin and depends upon so many factors that it is impossible to make any experimental corrections. At intervals, the epidermis is interrupted by hair follicles and it was necessary to avoid these because its thickness increases around their mouths. Great effort was made to make the method as objective as possible and ten measurements were always made at regular predetermined intervals over a distance of 10 mm. except where the mouth of a follicle intervened. In this event, the microscope stage was moved another half division on the vernier scale.

Experiments and Results

Several experiments were carried out to determine whether a mixture of acetone and distilled water (nine parts to one by volume) produced any changes in epidermal thickness. Even after repeated applications, no response could be demonstrated. After application of 0.3 ml. of this mixture on three consecutive days the mean

epidermal thickness was 7.3 μm . (6.92-7.61).

Following single applications of tobacco smoke condensate, the width of the epidermis appeared to fluctuate quite markedly (Table 1) but, on closer examination, it became evident that there was some connection between the thickness and the time at which the skins had been sampled. For this reason, only the results which had been obtained from samples taken at 08.30 hours are presented in the figures. Twenty-four hours after painting with tobacco smoke condensate, the increase in thickness was greatest after a 50 mg. dose and least with a 100 mg. dose, whereas after seventy-two hours the width of the epidermis was proportional to the dose level.

Figure I

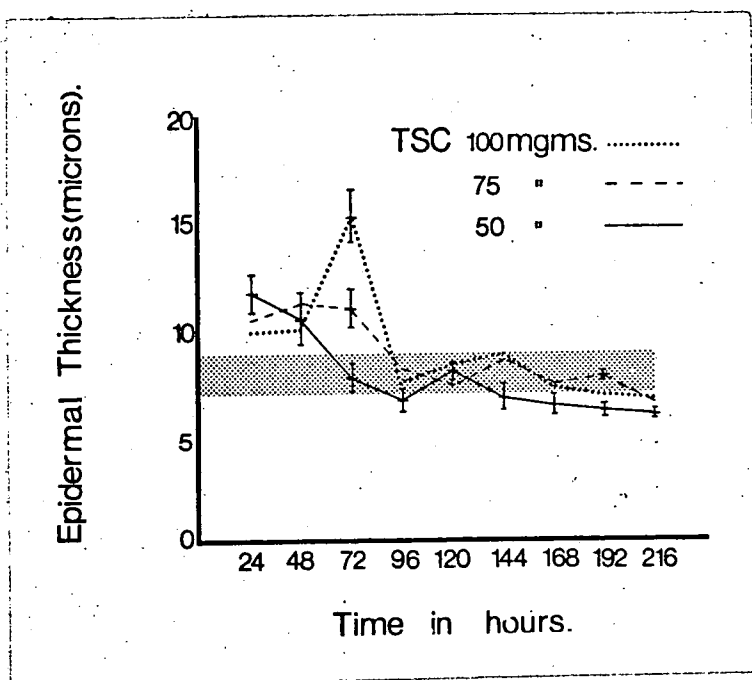

Comparison of the effect of a single application of three dose levels of tobacco smoke condensate (T. S. C.) on the thickness of the living layer of epidermal cells measured on a section perpendicular to the surface of the skin.

In association with this it appeared that the time of maximum response varied according to the dose level, twenty-four hours with 50 mg., forty-eight hours with 75 mg. and seventy-two hours with 100 mg. By the fifth day the epidermis had returned to normal thickness but this was followed by an almost imperceptible decrease in the thickness. Treatment with tobacco smoke condensate in the presence of 3.4 - benzpyrene resulted in a more persistent response accompanied by changes in the time of maximum response, in addition to a slight increase in magnitude (Table 2).

Figure 2

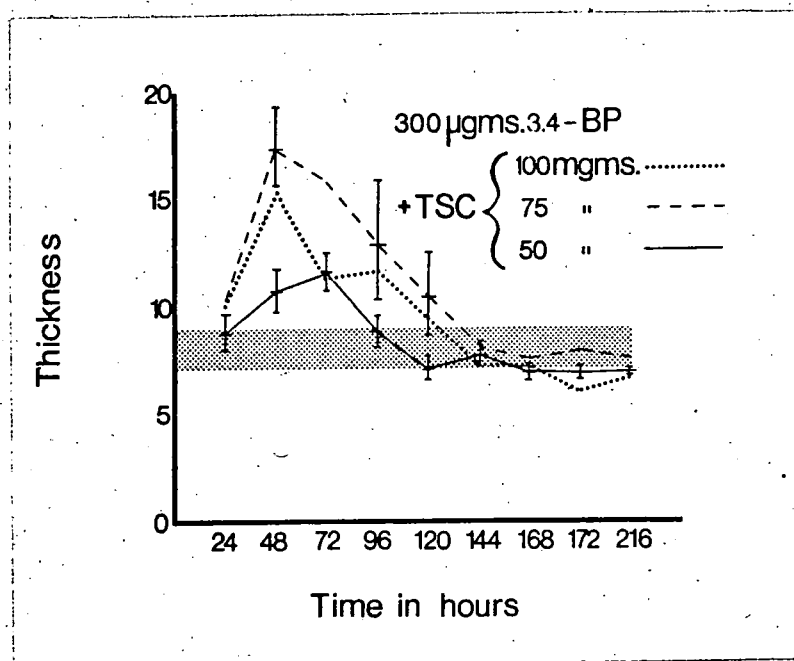

Changes in epidermal thickness throughout the ten days following a single application of three different dose levels of tobacco smoke condensate (T. S. C.) to which a standard amount (300 µg.) of 3.4 benzpyrene had been added.

TABLE 1

Single Application of Three Dose Levels of Tobacco Smoke Condensate

Time after Application (Hours)	(100 mg.)		(75 mg.)		(50 mg.)	
	Mean Epidermal Thickness (μm)	68% Confidence Limits	Mean Epidermal Thickness (μm)	68% Confidence Limits	Mean Epidermal Thickness (μm)	68% Confidence Limits
5	6.1	5.6 - 6.7	9.0	8.5 - 9.5	5.7	5.5 - 6.0
12	10.6	10.1 - 11.2	9.0	8.3 - 9.8	8.5	7.8 - 9.3
24	9.9	9.2 - 10.7	10.5	9.7 - 11.4	11.7	10.9 - 12.6
31	13.7	12.8 - 14.8	9.2	8.4 - 10.1	12.7	11.7 - 13.8
48	10.0	9.2 - 11.0	11.2	10.6 - 11.9	10.5	9.3 - 11.8
55	11.6	10.4 - 12.8	13.3	12.4 - 14.2	9.1	8.8 - 9.5
72	15.3	14.1 - 16.6	11.0	10.2 - 11.9	7.8	7.2 - 8.5
79	9.0	8.6 - 9.5	7.1	6.4 - 7.8	8.7	7.5 - 10.0
96	7.7	7.2 - 8.1	8.2	7.5 - 8.9	6.7	6.2 - 7.3
103	7.4	7.0 - 7.8	8.4	7.9 - 8.8	6.3	6.0 - 6.6
120	8.5	7.8 - 9.2	7.5	7.1 - 8.0	8.2	7.8 - 8.6
145	8.8	8.4 - 9.3	8.7	7.7 - 9.8	6.9	6.4 - 7.6
168	7.3	6.8 - 7.9	7.6	6.6 - 8.7	6.5	6.1 - 7.0
192	6.9	6.4 - 7.3	7.8	7.6 - 8.1	6.3	6.0 - 6.6
216	6.7	6.4 - 7.0	6.6	6.3 - 6.9	6.1	5.9 - 6.3

TABLE 2

Single Application of Three Dose Levels of Tobacco Smoke Condensate and 300 ugms. of B. P.

Time after Application (Hours)	(100 mgs)		(75 mgs)		(50 mgs)	
	Mean Epidermal Thickness (µm)	68% Confidence Limits	Mean Epidermal Thickness (µm)	68% Confidence Limits	Mean Epidermal Thickness (µm)	68% Confidence Limits
5	5.6	5.1 - 6.2	6.6	6.1 - 7.2	7.2	6.8 - 7.6
12	8.6	7.8 - 9.4	7.4	7.0 - 7.9	8.4	7.4 - 9.4
24	10.1	9.3 - 10.9	10.2	9.7 - 10.8	8.7	8.0 - 9.6
31	16.0	14.7 - 17.4	10.6	10.2 - 10.9	11.9	10.9 - 12.9
48	15.2	13.9 - 16.7	17.5	15.7 - 19.4	10.7	9.8 - 11.8
55	16.0	13.4 - 19.0	14.6	11.7 - 18.2	6.7	6.4 - 7.0
72	11.4	10.2 - 12.7	15.9	12.6 - 20.1	11.6	10.8 - 12.5
79	15.2	13.2 - 17.4	11.8	10.1 - 13.8	11.6	10.0 - 13.5
96	11.6	9.7 - 14.0	12.9	10.4 - 16.0	8.8	8.2 - 9.6
103	8.0	7.1 - 9.0	9.2	8.1 - 10.6	7.3	7.0 - 7.6
120	9.5	8.5 - 10.6	10.4	8.7 - 12.5	7.1	6.6 - 7.7
145	7.2	6.4 - 8.2	8.1	7.7 - 8.5	7.7	7.2 - 8.3
168	7.2	6.6 - 7.8	7.5	7.1 - 8.0	6.9	6.5 - 7.3
192	6.0	5.5 - 6.6	7.9	7.3 - 8.6	6.9	6.6 - 7.2
216	6.7	6.3 - 7.1	7.5	7.1 - 8.0	7.0	6.9 - 7.1

Figure 3

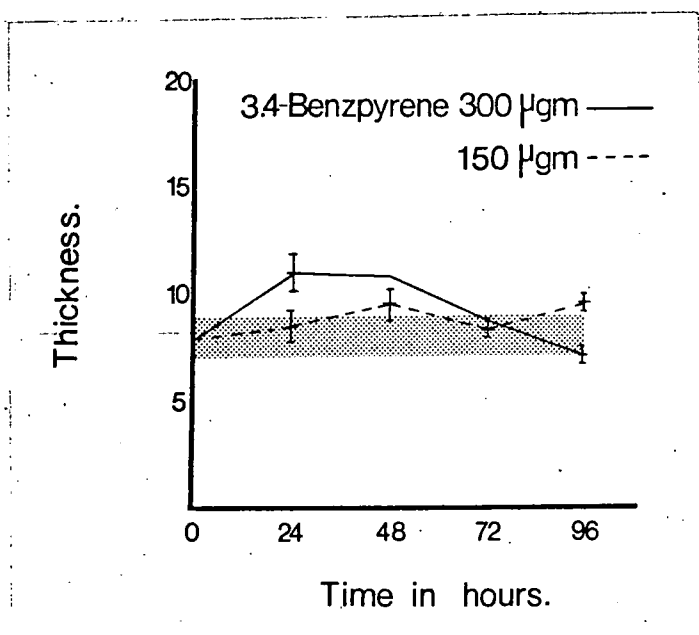

The effect of two dose levels of 3.4 benzpyrene on epidermal thickness. Painting was carried out at 08.30 hours G.M.T. (0 hours on the abscissa)

3.4 Benzpyrene treatment alone produced a slight thickening, but with the lower dose level this is almost negligible. The response was nowhere near as marked as that produced by tobacco smoke condensate. The greater part of the thickening appeared to be due to hypertrophy rather than hyperplasia. Cytoplasmic vacuolation and accumulation of chromatin within the nuclei were observed, but the majority of cells appeared to recover fairly rapidly and very few degenerated completely. Pyknosis and karyolysis were observed very infrequently.

The irritants, phenol and toluene (Table 4)

Figure 4

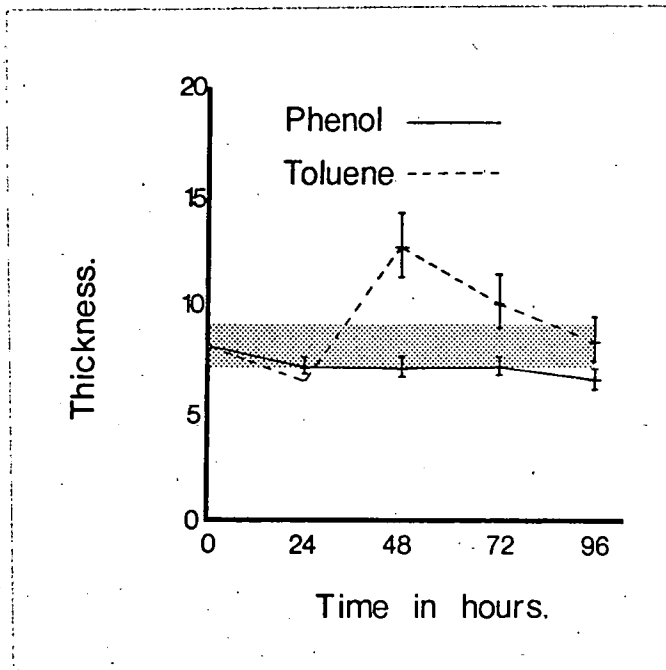

Effect of a single application of phenol and toluene on epidermal thickness over the next four days.

(Dose levels: Phenol - 1.41 mg. Toluene - 0.3 ml.)

appeared to have different effects at the dose levels applied. Phenol depressed the activity of the tissue whereas toluene caused extensive damage resulting in a typical regenerative hyperplasia coupled with much inflammation. Some parts of the epidermis were destroyed completely and there was extensive ulceration in many areas. This was so bad in two of the samples that they could not be measured.

A group of untreated mice were also killed at the same time intervals and over the same period as the 3,4 - benzpyrene experiment. The shaded area in each of the figures represents the 98 per cent confidence limits calculated from the measurements of the samples taken at 08.30 hours.

Ethanol and dimethylsulphoxide (DMSO) both produced changes in the epidermal thickness and this suggests that they would be unsuitable for use as solvents. The results are presented in Table 4.

Figure 5

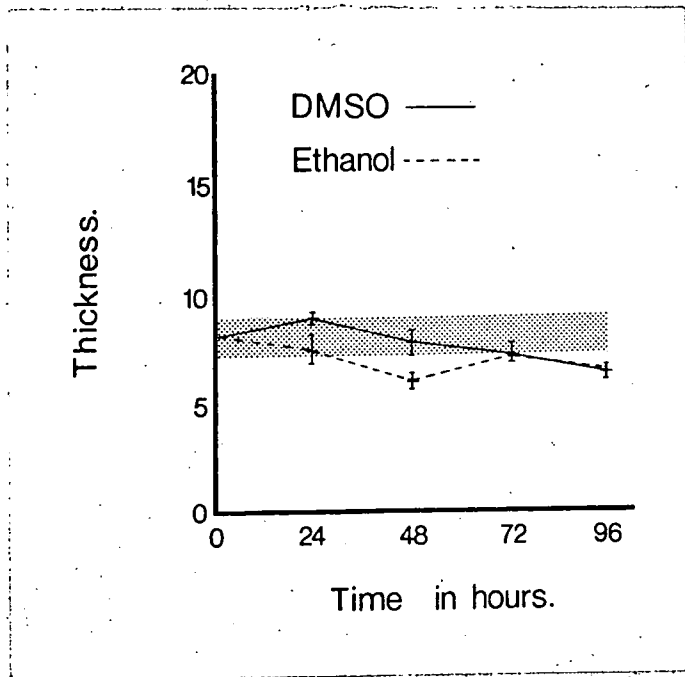

Effect of a single application of 0.3 ml. of dimethylsulphoxide and ethanol on epidermal thickness over the next four days.

100 mg. of smoke condensate in 0.3 ml. of 90 per cent aqueous acetone were applied to the shaved dorsal midline of a batch of mice on fourteen consecutive days. From the second day six mice were removed each day and a piece of skin was excised from the treated area of each mouse. Control mice were treated with the same volume of pure solvent. Sufficient mice had been included to continue withdrawing six mice from both the control and the treated group for a further period of fourteen consecutive days after dosing had terminated, in order to gain information about the recovery period.

Examination of the sections obtained from the control mice showed that no hyperplasia developed and application of the solvent alone had no observable effect upon any of the skin layers. The results obtained from the treated skins are presented in Table 5 and Figure 6.

Figure 6

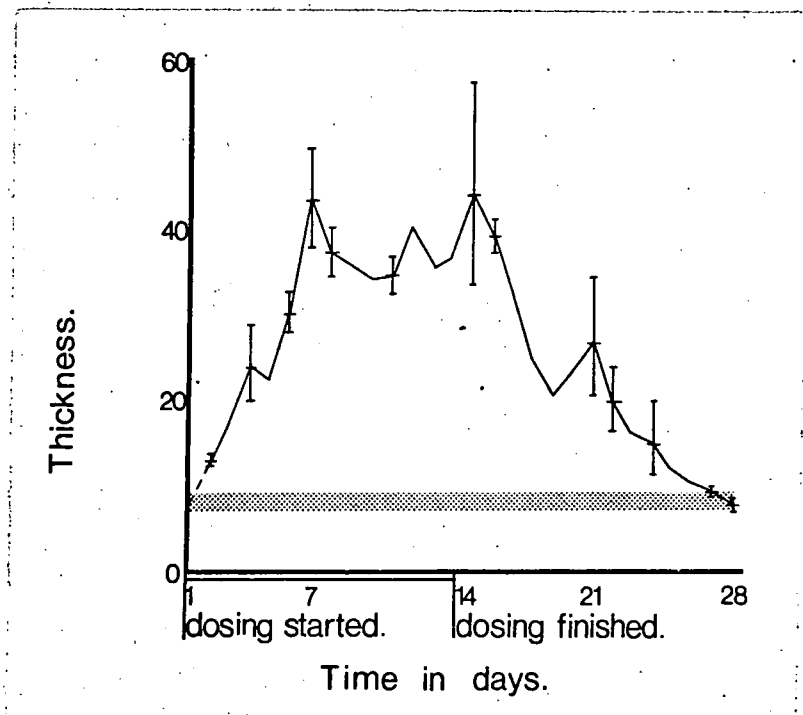

The response of the epidermis to repeated applications of 100 mg. of tobacco smoke condensate on fourteen consecutive days as measured by changes in epidermal thickness.

The epidermis thickened rapidly to reach a maximum on the seventh day and this level was maintained until after treatment had stopped. On the ninth day the skins of all the mice were so badly ulcerated that measurements could not be made. The mean epidermal thickness had returned to normal by the twenty-eighth day.

TABLE 3

Single Application of Two Dose Levels of BP Compared with Untreated Controls

Time after Application (Hours)	BP - 300 µg.		BP - 150 µg.		Untreated Controls	
	Mean Epidermal Thickness (µm)	68% Confidence Limits	Mean Epidermal Thickness (µm)	68% Confidence Limits	Mean Epidermal Thickness (µm)	68% Confidence Limits
5	-	-	7.1	6.8 - 7.4	6.8	6.6 - 7.0
7	6.8	6.1 - 7.6	-	-	-	-
12	-	-	7.4	7.2 - 7.6	7.6	7.0 - 8.1
24	10.9	10.0 - 11.8	8.4	7.8 - 9.2	8.5	8.1 - 8.9
31	13.2	12.2 - 14.2	8.5	7.7 - 9.5	6.6	6.1 - 7.0
48	10.5	9.8 - 11.2	9.3	8.6 - 10.2	7.5	7.3 - 7.7
55	9.5	8.6 - 10.4	9.7	9.0 - 10.5	6.9	6.5 - 7.3
72	8.8	7.9 - 9.7	8.2	7.8 - 8.6	8.3	7.7 - 8.9
79	8.8	8.3 - 9.2	7.3	6.8 - 7.8	8.9	8.6 - 9.2
96	7.0	6.6 - 7.5	9.5	9.1 - 9.9	7.3	6.9 - 7.8
103	6.9	6.5 - 7.3	7.4	6.7 - 8.2	7.1	6.5 - 7.7

TABLE 4

Single Application of Irritants and Solvents

(Mean Values Followed by 68 per cent Confidence Limits in Brackets)

<u>Time after Application (Hours)</u>	<u>Phenol</u>	<u>Toluene</u>	<u>Ethanol</u>	<u>DMSO</u>
5	5.8 (5.4-6.2)	3.7 (2.5- 5.4)	7.1 (6.6-7.6)	6.7 (6.4- 7.1)
12	6.5 (6.2-6.9)	*	6.9 (6.8-7.1)	6.9 (6.5- 7.2)
24	7.2 (6.8-7.6)	6.7 (5.1- 8.8)	7.4 (6.9-8.0)	8.8 (8.5- 9.1)
31	7.3 (6.9-7.7)	12.7 (11.3-14.3)	6.7 (6.5-6.8)	8.5 (8.0- 9.0)
48	7.0 (6.6-7.5)	*	6.0 (5.6-6.3)	7.8 (7.2- 8.4)
55	7.3 (6.7-7.9)	10.4 (9.3-11.6)	6.7 (6.3-7.0)	7.5 (6.7- 8.4)
72	7.2 (6.8-7.7)	10.2 (9.0-11.5)	7.2 (6.8-7.6)	7.2 (6.7- 7.7)
79	7.0 (6.3-7.8)	9.4 (8.9- 9.9)	6.4 (6.2-6.7)	8.9 (8.0-10.0)
96	6.6 (6.1-7.2)	8.4 (7.4- 9.5)	6.5 (6.1-6.9)	6.4 (6.0- 6.7)
103	7.3 (7.0-7.7)	9.5 (8.8-10.3)	7.1 (6.6-7.7)	7.0 (6.6- 7.3)

DMSO - Dimethylsulphoxide

*Extensive ulceration

TABLE 5

Application of Tobacco Smoke Condensate (100 mg.) on Fourteen Consecutive Days

Time after First Application (Days)	Mean Epidermal Thickness (μm)	68% Confidence Limits	Time after First Application (Days)	Mean Epidermal Thickness (μm)	68% Confidence Limits
	Thickness (μm)	Limits	Application (Days)	Thickness (μm)	Limits
1	13.0	12.4-13.7	15	39.1	37.1-41.1
2	16.7	15.7-17.8	16	32.8	27.3-39.4
3	23.7	19.6-28.6	17	24.9	19.2-32.1
4	22.3	18.7-26.6	18	20.5	16.4-25.6
5	29.7	27.1-32.5	19	23.1	17.5-30.5
6	43.2	37.7-49.4	20	26.5	20.5-34.3
7	37.2	34.4-40.2	21	19.7	16.3-23.8
8	*		22	16.0	13.7-18.8
9	34.2	32.8-35.7	23	14.8	11.1-19.8
10	34.4	32.3-36.6	24	12.0	10.7-13.4
11	40.2	35.9-45.0	25	10.4	9.0-12.1
12	35.6	32.6-38.9	26	9.2	8.6- 9.9
13	36.7	34.1-39.4	27	7.5	6.8- 8.3
14	43.7	33.4-57.2	28	**	

* Extensive ulceration

**Insufficient skins for measurement owing to death of four animals during experimental period

DISCUSSION

After repeated applications of tobacco smoke condensate, the epidermis become transformed into a layer about eight times its normal width in a comparatively short time. This remarkable increase appeared to have come about as a result of changes in all three of the features mentioned in Chapter I, but the rapidity with which it regained its former width when administration was stopped, suggested that inhibition of differentiation was the main contributing factor. It is difficult to understand how enough desoxyribonucleic acid (DNA) could have been synthesised rapidly enough to keep pace with such a vast increase in the cell synthesising process.

Comparison of the qualitative observations made on these treated samples of epidermis suggested that the thickening produced by the tobacco smoke condensate was due more to a stimulating effect, whereas after 3.4 benzpyrene treatment some regeneration in response to cell damage was responsible. With an irritant such as toluene, the process would seem to be entirely regenerative.

Both dose levels of 3.4 benzpyrene would produce a high proportion of skin tumours after repeated application to mouse skin (Badger, Cook, Hewett, Kennaway, Martin and Robinson, 1940), whereas tobacco smoke condensate is not nearly so potent (Day, 1967) and yet the increase in thickness after 3.4 benzpyrene treatment was much less than that obtained with tobacco smoke condensate. It is clear, therefore, that the neoplastic process is not dependent upon the magnitude of the disturbance in the epidermal cell population. It

is possible that it is more concerned with the combination of the two influences; a stimulative mechanism and a regenerative mechanism. Tobacco smoke condensate may act primarily as a stimulant of cellular proliferation but, if it is applied in sufficient quantity over a long period, the accumulation of toxic substances is great enough to exceed the irritant threshold and bring about malignancy.

CONCLUSIONS

- (i) Epidermal thickness is increased after application of tobacco smoke condensate, 3.4 - benzpyrene and toluene. It is, therefore, not a specific response to painting with a carcinogen.
- (ii) Increase in thickness was greater after treatment with smoke condensate than after 3.4 - benzpyrene. Carcinogenic activity is not quantitatively related to increase in epidermal thickness.
- (iii) Degenerative cellular changes were most pronounced after treatment with the non-carcinogenic irritants. There was some evidence of these after treatment with smoke condensate, but they were more apparent after 3.4 - benzpyrene.
- (iv) Measurement of increase in epidermal thickness alone is an unsuitable method of comparing the carcinogenic activity of chemical substances.

CHAPTER 5

THE EFFECT OF VARIOUS SUBSTANCES ON THE RATE OF CELLULAR DIVISION OF THE EPIDERMAL CELL POPULATION IN THE AREA OF TOPICAL APPLICATION

INTRODUCTION

Stathmokinetic agents
Proliferation rate
Mitotic duration

METHODS

Cell counting
Histology

RESULTS

Control
3.4 - Benzpyrene
Tobacco smoke condensate
Neutral fraction
Efficiency of arrest

DISCUSSION

CONCLUSION

New cells are produced in the epidermis by division of the basal cells (Flemming, 1884). After division, one or both of the daughter cells may start to differentiate or they may remain as basal cells and either divide or differentiate some time later (Greulich, 1964). Mitosis can be arrested by treatment with certain substances such as colchicine and colcemid.

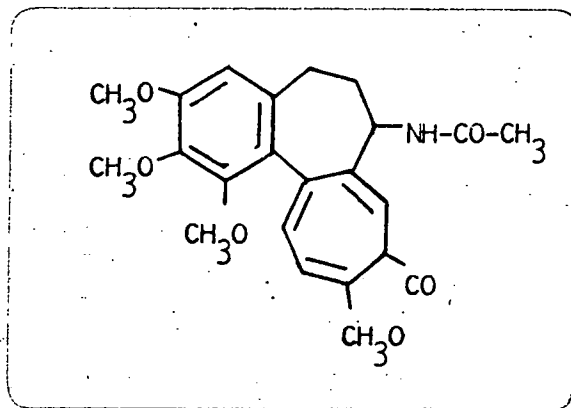

Colchicine

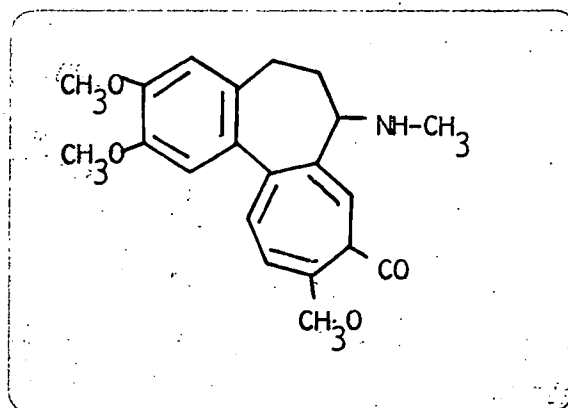

Colcemid

These alkaloids are believed to act by inhibiting the formation of the spindle in metaphase, but the passage of dividing cells which are in anaphase and telophase at the time of injection suffers no interference. The action of colchicine on the cells and its use as a stathmokinetic agent have been extensively studied (Eigsti and Dustin, 1955; Dustin, 1959; Bertalanffy, 1964). 0.2 mg. per 100 g. body weight of colchicine injected subcutaneously into mice, arrests metaphase nuclei for up to about eighteen hours. If the mice are killed only a few hours after injection, before sufficient time as elapsed for the

effect of the drug to become diminished, the number of cells accumulated in mitosis per unit of time gives an estimate of the rate of cellular division.

$$K = \frac{N_m^A}{D^A}$$

where: K = proliferation rate (mitosis per hour)
 N_m^A = percentage of arrested metaphases
 D^A = duration of arrest (hours)

In order to ensure an efficiency of 100 per cent, the mice in these experiments were killed six hours after injection of colchicine. Four consecutive groups of six animals were used to furnish data on the percentage of cells dividing in the epidermis during a complete twenty four hour period. The six animals of the first group were injected with colchicine and killed six hours later, when the second group was injected and so on. The epidermis of the twenty-four animals combined contain, arrested in metaphase, all the cells which entered division during the twenty-four hour period. The entry of the cells into division is not affected by treatment with colchicine. Colchicine treatment in each experiment was started exactly forty-eight hours after painting and the last group of mice was killed seventy-two hours after painting. An additional group of mice was killed sixty hours after painting. These were not treated with colchicine and the mitotic counts from these animals represent the proportion of cells dividing at the instant of sampling. The duration of mitosis can be calculated from the following formula:

where: T_m = duration of mitosis

$$T_m = \frac{N_m}{K}$$

N_m = percentage of mitotic figures

K = proliferation rate (Mitoses per hour)

METHOD OF MEASUREMENT

Ten groups of one hundred nucleated cells were differentiated at one millimetre intervals down the epidermis of each section. Prophase nuclei were counted as interphase nuclei, but any anaphase and telophase nuclei, which would indicate inefficiency of arrest, were enumerated.

HISTOLOGY

Preliminary studies on skins fixed in Lillie's calcium formol, Bouin, Zenker, Helly, Clarke, Carnoy and Newcomer's fixatives and formol saline indicated that Zenker-acetic and Bouin were by far the best for staining with Ehrlich's haematoxylin and eosin. The slightly more eosinophilic staining after Zenker, made the mitotic figures more conspicuous and easier to differentiate than after Bouin fixation.

RESULTS

The results obtained from the control animals were compared with those obtained after treatment with the neutral fraction using the Student's 't' test:

<u>Time Period</u>	<u>Probability</u>
48-54	0.001-0.01
54-60	0.001-0.01
60-66	0.01 -0.02
66-72	0.02 -0.05

TABLE 6

Comparison of the Arrested Metaphase Index (N_m^A) over different Periods after Treatment with Benzpyrene (BP), Tobacco Smoke Condensate (TSC) and the Neutral Fraction (NF)

(Six mice per group)

Periods of Arrest after Application (Hours)	Control	N_m^A (S. E.)	TSC	NF
		BP		
48 - 54	3.17 (0.90)	7.50 (3.48)	117.33 (24.28)	17.00 (6.22)
54 - 60	2.00 (0.77)	5.83 (0.56)	91.80 (34.37)	6.33 (1.14)
60 - 66	2.50 (0.73)	3.50 (0.84)	24.42 (14.17)	7.33 (2.30)
66 - 72	3.00 (0.65)	2.17 (0.40)	36.58 (13.75)	7.17 (2.20)

TABLE 7

Comparison of Proliferation Rate (K) over Different Periods after Treatment with Benzpyrene (BP), Tobacco Smoke Condensate (TSC) and the Neutral Fraction (NF)

Periods of Arrest after Application (Hours)	Control	K (Calculated from Table 6)			NF
		BP	TSC		
48 - 54	0.53	1.25	19.55	2.83	
54 - 60	0.33	0.97	15.30	1.06	
60 - 66	0.42	0.58	4.07	1.22	
66 - 72	0.50	0.36	6.10	1.19	

TABLE 8

Comparison of the Mitotic Index (Nm) Sixty Hours after =
Application of the Test Substances

Substance Painted	Total Count	Nm.
Solvent only	15/30,000	0.83
Benzpyrene (300 µg.)	89/18,000	4.94
Tobacco smoke condensate (100 mg.)	193/18,000	10.37
Neutral fraction (100 mg. equivalent)	51/18,000	2.83

TABLE 9

Comparison of Duration of Mitotic Division (Tm), Sixty
Hours after Application of the Test Substances

	Tm (Nm/K) Hours
Solvent only	2.22
Benzpyrene	6.36
Tobacco smoke condensate	1.11
Neutral fraction	2.49

The proliferation rate over the forty-eight to fifty-four hour period was found to be significantly different ($p = 0.02-0.05$) from that of the fifty-four to sixty hour period after painting with neutral fraction. (For an explanation of the origin of the neutral fraction see Chapter 9).

Anaphase and telophase figures were present in small proportion in two of these experiments (tobacco smoke condensate - 1.035%; 3.4 benzpyrene - 12.28%) so it is doubtful how much significance can be attached to these results. These phases of mitosis were not seen in the control experiment or after treatment with the neutral fraction and they were never observed lower down the hair follicles than 20 μm from the top. Elgjo (1966) has described a method for testing the efficiency of the arresting agent whereby specimens of skin are taken one, two, three, four, five and six hours after injection and the time at which the increasing straight line collection of mitoses begins to fall off indicates the duration over which the drug is effective. Experiments were carried out using this technique to test colchicine, colcemid and vinblastine by intraperitoneal, intravenous and subcutaneous injection.

Figure 7

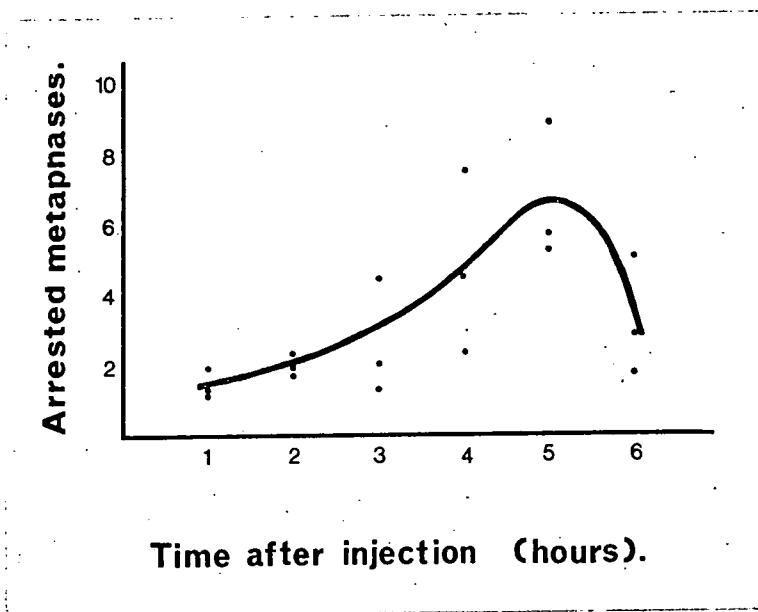

Incidence of arrested metaphase figures after increase in the duration of treatment with colchicine. The maximum point (here shown to be after five hours) is considered by some authorities to indicate the limit of efficiency of the arresting agent, but this technique does not take into account the fluctuations in mitotic activity associated with a diurnal rhythm.

Straight line collections of arrested metaphases were obtained (Figure 7) up to five hours, but in every experiment a few anaphase and telophase figures were seen in sections taken from earlier samples.

DISCUSSION

The reliability of this method would seem very doubtful in view of the incidence of anaphase and telophase figures and the results obtained are probably best used as a guide to the interpretation of the general changes which are taking place. Changes resulting from treatment are obviously still taking place seventy-two hours after application and these are quite marked with the tobacco smoke condensate and the neutral fraction. The rate of proliferation in all cases is rapidly

returning to normal throughout the forty-eight to seventy-two hour period. According to Montagna (1962) the normal duration of mitosis is about two and a half hours which is in very good agreement with the results obtained from the control and neutral fraction experiments. The value obtained after the 3.4 - benzpyrene treatment is absurd because the total time of arrest was only six hours.

CONCLUSIONS

This technique proved too unreliable to draw any firm conclusions.

CHAPTER 6

THE EFFECT OF A CARCINOGENIC AND A NON-CARCINOGENIC POLYCYCLIC AROMATIC HYDROCARBON ON THE EPIDERMIS COMPARED WITH THAT OF A NON-CARCINOGENIC IRRITANT

DIURNAL VARIATION IN MITOTIC DIVISION

TEST SUBSTANCES

20 - Methylcholanthrene
1.2 - Benzanthracene
Allyl-iso-thiocyanate

METHODS OF MEASUREMENT

Epidermal thickness
Cell population
Mitotic Index
Cell size

EXPERIMENTAL PROCEDURE

RESULTS

Diurnal rhythm
Unshaved, shaved and solvent painted
controls
Treated mice

DISCUSSION

CONCLUSIONS

This section of the work is concerned primarily with the relative contributions of hyperplasia and hypertrophy to increase in epidermal thickness. A parallel investigation of the mitotic index was carried out to determine whether there was any correlation between incidence

of cellular division and the size of the epidermal population. Because the measurements on proliferation rate had been anomalous, the normal frequency of epidermal mitosis throughout a complete twenty-four hour period was examined to determine whether it was associated with a diurnal rhythm. This proved to be the case. The precautions involving consistent shaving, painting and sampling at the same time of day were shown to be of very great importance. Moreover, the highest incidence of cellular division was seen to occur in the middle of the day, an observation which demonstrated that the mice were still behaving as nocturnal animals, in spite of the experimental conditions, and from this time the experimental room was permanently locked and only visited when it was absolutely necessary.

One example of each class of test substances was examined and the solvent in each case was the same (90 per cent aqueous acetone).

A Carcinogenic Polycyclic Hydrocarbon - 20 Methylcholanthrene

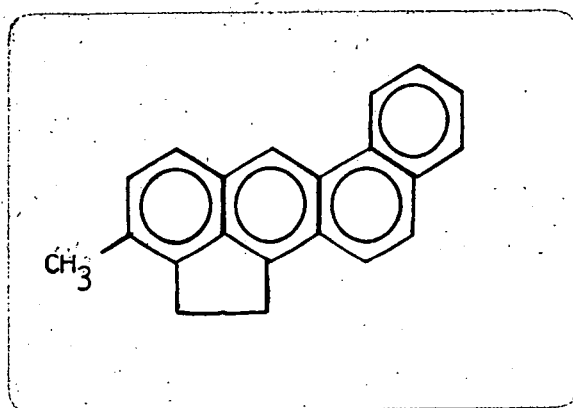

The carcinogenicity of methylcholanthrene is well known (Cramer and Stowell, 1943). In addition the early response of mouse epidermis to application of this carcinogen has been studied in detail (Cramer and Stowell, 1942, 1943 a and b; Liang, 1947; Reller and Cooper, 1944; Simpson and Cramer 1943, 1945; Suntzeff and Carruthers, 1946; Terracini, Shubik and Della Porta 1960; Iversen and Evensen, 1962; and Elgjo, 1966).

A Non-Carcinogenic Polycyclic Hydrocarbon - 1,2 Benzanthracene

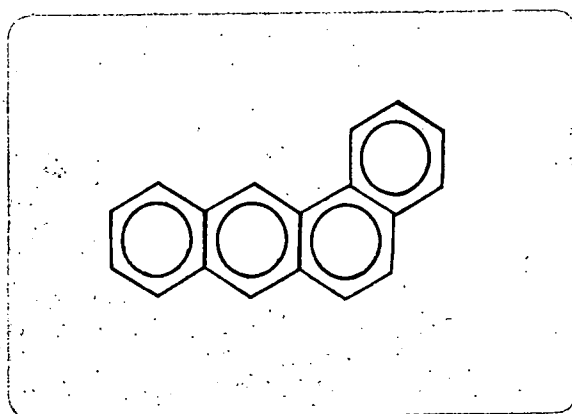

There are conflicting reports in the literature concerning the activity of benzanthracene. Occasional tumours have been noted after skin painting but these are generally considered to have developed 'spontaneously' (Kennaway, 1930; Barry, Cook, Haselwood, Hewett, Hieger and Kennaway, 1935; and Hill Stanger, Pizzo, Riegel, Shubik and Wartmann, 1951). Berenblum (1941) was unable to demonstrate an initiating activity with this compound in an experiment in which a saturated solution of benzanthracene in acetone containing 0.025 per cent croton oil resin was painted on twenty consecutive weeks. Graffi, Vlamynck, Hoffmann and Schulz (1953) and Roe and Salaman (1955) succeeded in inducing skin tumours to arise with very high doses of benzanthracene and subsequent croton oil treatment. Samples of benzanthracene obtained from the manufacturers generally contain quantities of related polycyclic hydrocarbons which would be sufficient to initiate neoplastic activity and precautions should be taken to increase their purity. The sample used in this work was purified by repeated recrystallization from ethanol.

A Non-Carcinogenic Irritant - Allyl-iso-thiocyanate

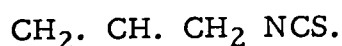

This compound is the active ingredient of mustard and it seems unlikely that it possesses any carcinogenic or cocarcinogenic activity, but this has never been confirmed experimentally.

METHODS OF MEASUREMENT

Epidermal Thickness

The width of the epidermis was measured with a scale on a graticule incorporated in the microscope eyepiece (Plate 14). The graticule divisions represented 1.042 μm . at the magnification used.

During processing there is a tendency for the stratum corneum to become displaced from the surface in some areas, so only the thickness of the non-cornified layers were measured in this way.

'Number of Cells per Millimetre' of Epidermis

The eyepiece graticule (Plate 14) was also inscribed with a square around the measuring scale used for thickness measurements, and the number of nuclei within this area was enumerated at ten different locations on each section of epidermis. These locations correspond to readings on the vernier scale of the stage and were pre-selected to avoid subjective errors. Only nuclei in the interfollicular epidermis were counted.

Mitotic Index

Ten groups of one hundred nucleated cells were differentiated at one millimetre intervals down the epidermis of two sections from each mouse. In some experiments, interphase, prophase, metaphase, anaphase and telophase nuclei were differentiated. In other experiments normal interphase nuclei, normal mitotic figures, atypical mitotic figures, invalid mitotic figures and degenerate cells were distinguished. Dissolution of the nuclear membrane was taken as the criterion for entry into prophase. The end of prophase was indicated by contraction of the chromosomes into a regular arrangement in the centre of the cell and this appeared oblong, when viewed equatorially, or annular in polar view. The separation into two clumps marked the beginning of anaphase. The beginning of telophase was signified by contraction of the cell membrane about the central axis and its

termination by breaking up of the chromatin and lack of regularity in its arrangement. Reappearance of the nuclear membrane is unsuitable as a criterion for the end of telophase. Atypical mitotic figures were recognised when chromatin bridges were present across the spindle or abnormally long chromatin arms projected from the main spireme. The mitotic figures were considered to be invalid when pieces of chromatin were distinctly observed to be lying outside the cell membrane. When the contents of the nuclear vesicles and the chromatin had become tightly packed into a dense basophilic mass or broken up into coarse fragments or when they had disappeared completely leaving a non-nucleated eosinophilic dead cell, these were counted as degenerate cells. In the second type of differential count normal, atypical and invalid mitotic figures were all included in calculating the actual mitotic index. The purpose of this type of count was to determine whether any correlation could be found between initiating activity and the proportion of atypical or invalid mitotic figures and between 'irritancy' and the proportion of degenerate cells.

Cellular Diameter

The size of the cells was calculated from the epidermal thickness and the number of cells per millimetre of epidermis:

$$\text{Diameter} = 2 \times \sqrt{\frac{\text{mean thickness} \times 1,000}{\text{number of cells per millimetre} \times \pi}}$$

This parameter is intended to be merely a guide to changes in cell size. It is based on the false assumption that the cells are perfectly

spherical and does not take into account any change in the size of the intercellular spaces. Nevertheless, so long as these deficiencies are borne in mind, it is a useful parameter for comparing hypertrophic changes.

EXPERIMENTAL PROCEDURE

Measurements were carried out on three batches of control mice to determine what effect shaving and application of solvent had upon the epidermis. Each batch consisted of twenty-four mice divided into four equal sized groups which were sampled at times equivalent to four, twelve, twenty-seven and seventy-five hours after solvent treatment. The first batch were untreated (A), the second batch were shaved along the dorsal midline (B) and the third batch were painted with 0.3 ml. of solvent twenty-two and a half hours after shaving (C). Mice which were not shaved or not painted were removed from their boxes and received sham treatment at the relevant time of day.

The effect of a single application of the solvent was examined over five consecutive days. Seventy-two mice were painted at 08.30 hours and then randomised into twelve groups of six. Four groups were killed on the day of painting and thereafter sampling was carried out twice a day at 11.30 hours and 20.30 hours.

Methylcholanthrene and Benzanthracene:

Seventy-two mice each received a single total dose of 300 µg. (0.3 ml. of a 0.1% solution in 90% aqueous acetone). Sampling was carried out as in the solvent control experiments.

Allyl-iso-thiocyanate

Preliminary experiments were carried out to establish the most-suitable dose level to be used. The compound, which is liquid at room temperature, was mixed with 90 per cent aqueous acetone to produce concentrations of 20 per cent, 10 per cent, 5 per cent and $2\frac{1}{2}$ per cent by volume. A 40 per cent concentration could not be obtained since it was non-miscible. Sampling was carried out two days after painting with the above concentrations and the epidermis was scored on the basis of increase in thickness and absence of nuclei in the cells adjacent to the basement membrane:

20% - All showed absence of nuclei

10% - One third showed absence of nuclei

5% - All showed an increased epidermal thickness

$2\frac{1}{2}$ % - All showed an increased epidermal thickness

Following these observations, a single application of 0.3 ml. of a 5 per cent solution was applied to seventy-two mice which were sampled in the normal manner.

RESULTS

Diurnal Rhythm

The mean mitotic index was determined in twelve groups of six mice which had been killed at two hourly intervals throughout a complete twenty-four hour period. These results are presented in Figure 8 and Table 10. The index followed a precise diurnal rhythm reaching

a maximum at about 14.30 hours and a minimum in the early hours of the morning.

Figure 8

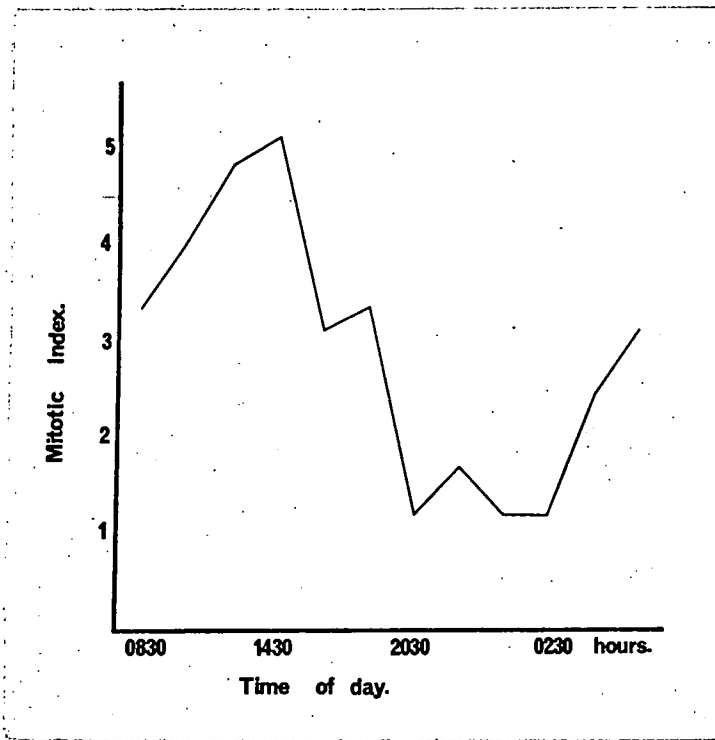

Changes in the mitotic index throughout a twenty-four hour period.

Control Observations

The results are presented in Table 11 and Figures 9-12

Figure 9

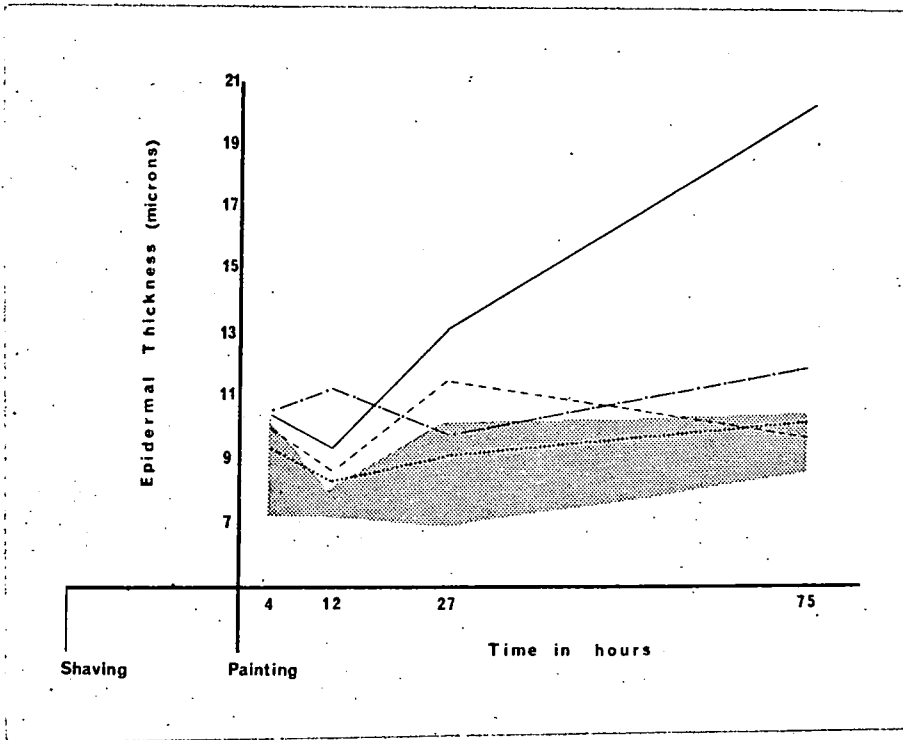

Variation in thickness of the epidermis in three groups of control mice compared with a single application of 300 μ g. of methylcholanthrene.

CONTROL A
(Sham shaving; sham painting)
CONTROL B - - - - -
(Shaved only)
CONTROL C -
(Shaved & painted with solvent)
TREATED _____
(0.3mls. of 0.1% 20:MC)

Figure 10

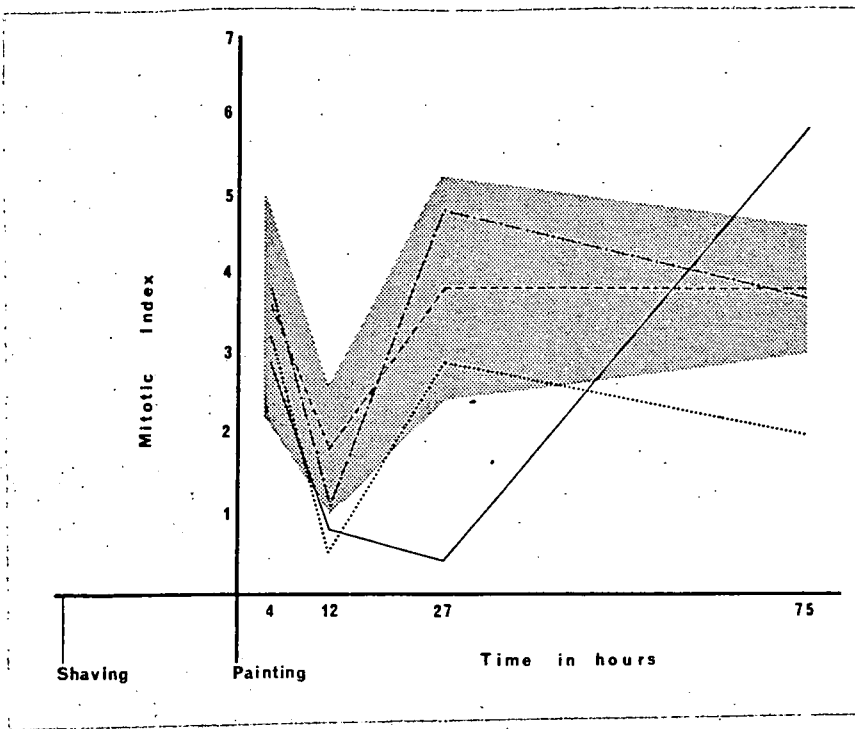

Changes in the mitotic index in the epidermis of three groups of control mice and one group of carcinogen treated mice.

Figure 11

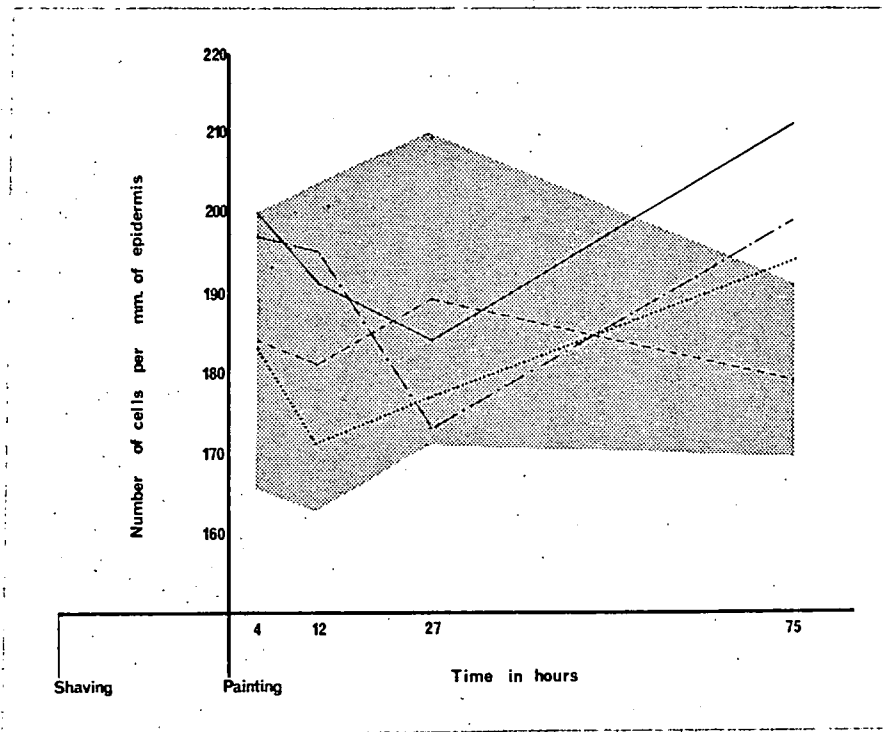

Variation in the epidermal cell population of three groups of mice treated with a single application of carcinogen.

TABLE 10

Time of Day	Mitotic Index
• 08.30	3.33
10.30	4.00
12.30	4.83
14.30	5.08
16.30	3.08
18.30	3.33
20.30	1.17
22.30	1.67
00.30	1.17
02.30	1.17
04.30	2.42
06.30	3.08

TABLE 11

Effect of Shaving and Application of Solvent on the Four Parameters Compared with Values obtained from Normal Untreated Animals. Mean Values are followed by 68 per cent Confidence Limits in Brackets

	Hours after Painting (in Series C)		
	3	12	27
Epidermal Thickness (μm)			
(a) Normal untreated	8.5 (7.8-9.3)	7.6 (7.4-7.8)	8.4 (7.6-9.2)
(b) Shaved untreated	9.3 (8.8-9.9)	8.1 (7.6-8.7)	10.5 (9.6-11.5)
(c) Shaved and solvent treatment	9.8 (8.9-10.7)	10.4 (10.0-10.9)	9.0 (8.5-9.6)
Mitotic Index			
(a) Normal untreated	0.32 (0.27-0.37)	0.05 (0.03-0.07)	0.29 (0.26-0.32)
(b) Shaved untreated	0.36 (0.29-0.43)	0.18 (0.14-0.22)	0.38 (0.31-0.45)
(c) Shaved and solvent treatment	0.38 (0.28-0.48)	0.11 (0.08-0.14)	0.48 (0.38-0.58)
Number of Cells per Millimetre			
(a) Normal untreated	183 (177-189)	171 (160-183)	177 (168-187)
(b) Shaved untreated	184 (175-192)	181 (172-192)	189 (180-199)
(c) Shaved and solvent treatment	197 (187-208)	195 (186-205)	173 (166-180)
Apparent Cellular Diameter (μm)			
(a) Normal untreated	7.7 (7.4-8.0)	7.5 (7.1-8.0)	7.8 (7.4-8.1)
(b) Shaved untreated	8.0 (7.9-8.1)	7.6 (7.4-7.7)	8.4 (8.1-8.7)
(c) Shaved and solvent treatment	7.9 (7.7-8.2)	8.2 (8.1-8.4)	8.1 (8.0-8.3)

Figure 12

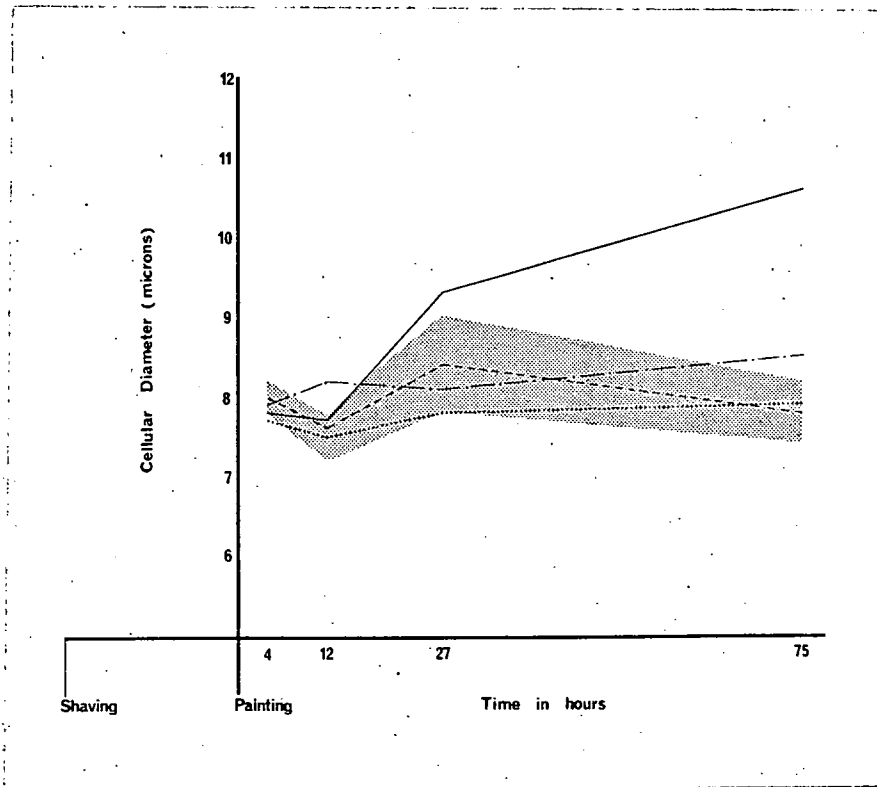

Variation in cell size following a single application of methylcholanthrene compared against three different types of controls.

The measurements of epidermal thickness and the mitotic counts of these three experiments were compared by analyses of variance. These confirmed that the thickness did not vary significantly over the experimental period, but shaving and subsequent application of the solvent brought about an increase in thickness. There was a slight insignificant increase after shaving, but a significant increase ($p < 0.01$) after both shaving and solvent treatment. In association with this, it was shown that shaving and painting with the solvent produced a significantly higher level ($p < 0.01$) of cellular division. The changes in mitotic index associated with diurnal rhythm

were also shown to be significant, ($p < 0.001$).

Control Samples over Five Days

Figure 13

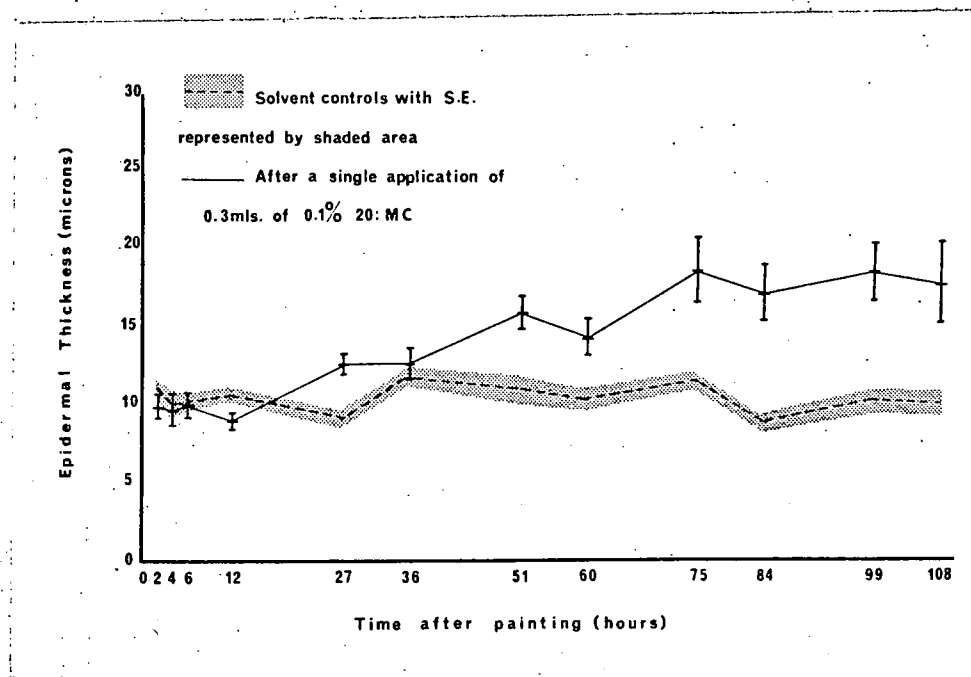

Increase in epidermal thickness following a single application of 300 μ g. of methylcholanthrene.

Figure 14

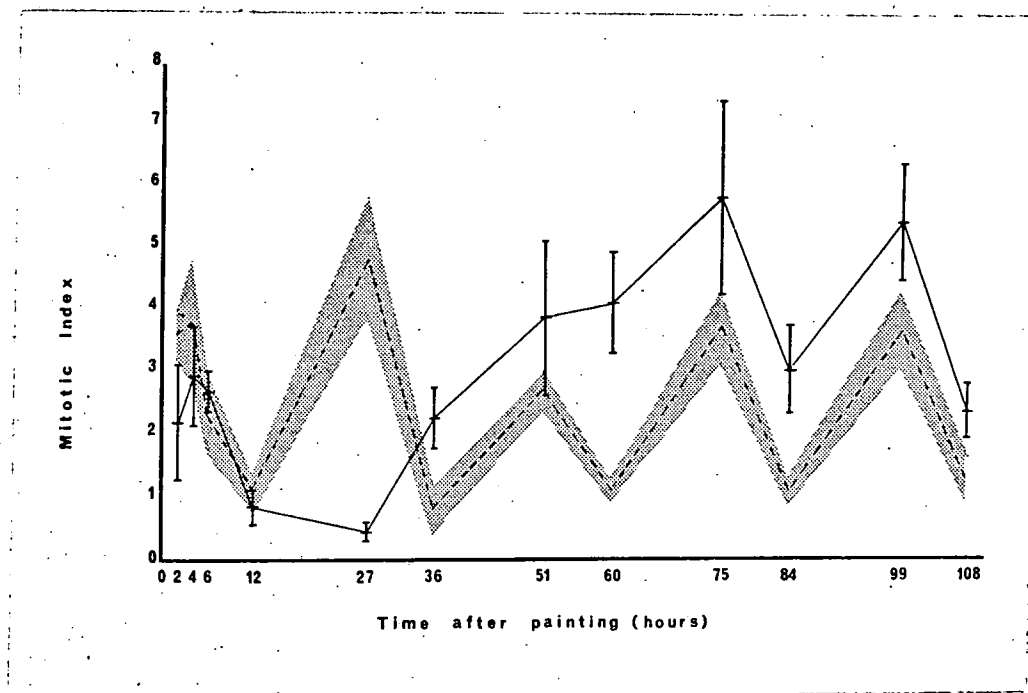

Variation in cellular division in the area of epidermis over the five days following exposure to a single application of methylcholanthrene. Note the almost total absence of mitosis twenty-seven hours after painting and the "compensating effect" on the fourth and fifth days.

The mitotic counts again showed a diurnal variation since the counts made on the evening samples were consistently lower than those at mid-day, resulting in five maximum points (Figure 14). On the first day and the last two days of sampling, the results were the same, but the maximum on the second day was somewhat higher and that on the third day somewhat lower than the average. It is not entirely clear whether this is associated with the solvent treatment but seem reasonably probable. The other parameters were all fairly constant and did not appear to be associated with a diurnal rhythm (Figures 13, 15 and 16).

Figure 15

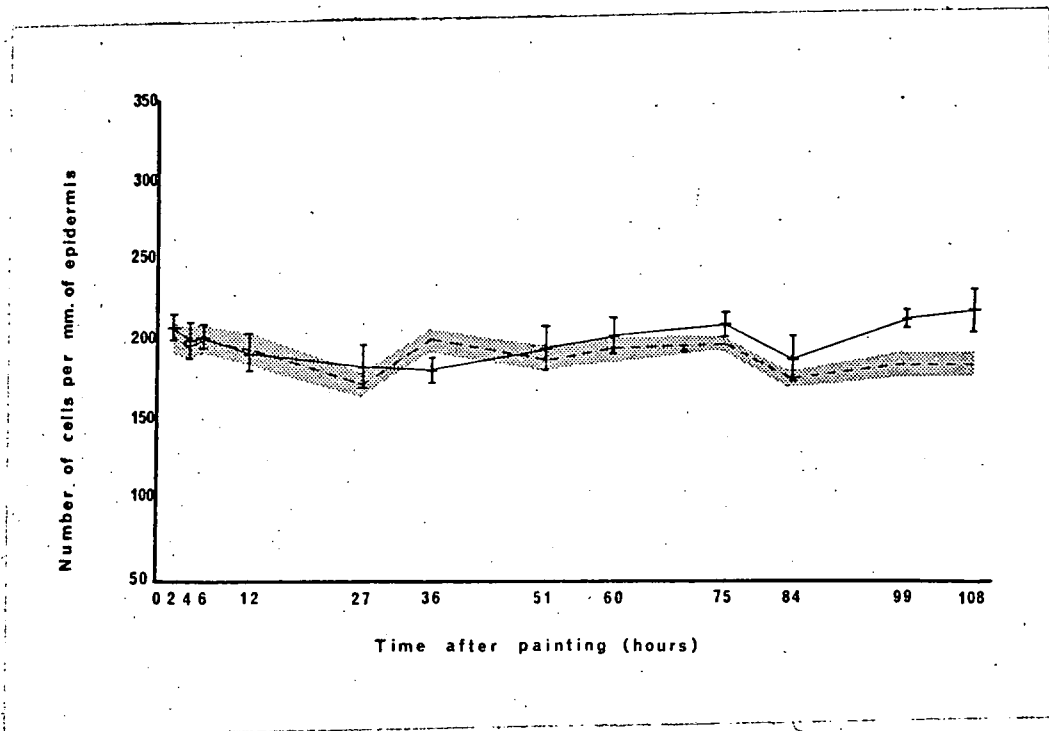

Changes in the epidermal cell population after exposure to methylcholanthrene. Note the hyperplastic changes on the fourth and fifth days in agreement with Figure 14.

Figure 16

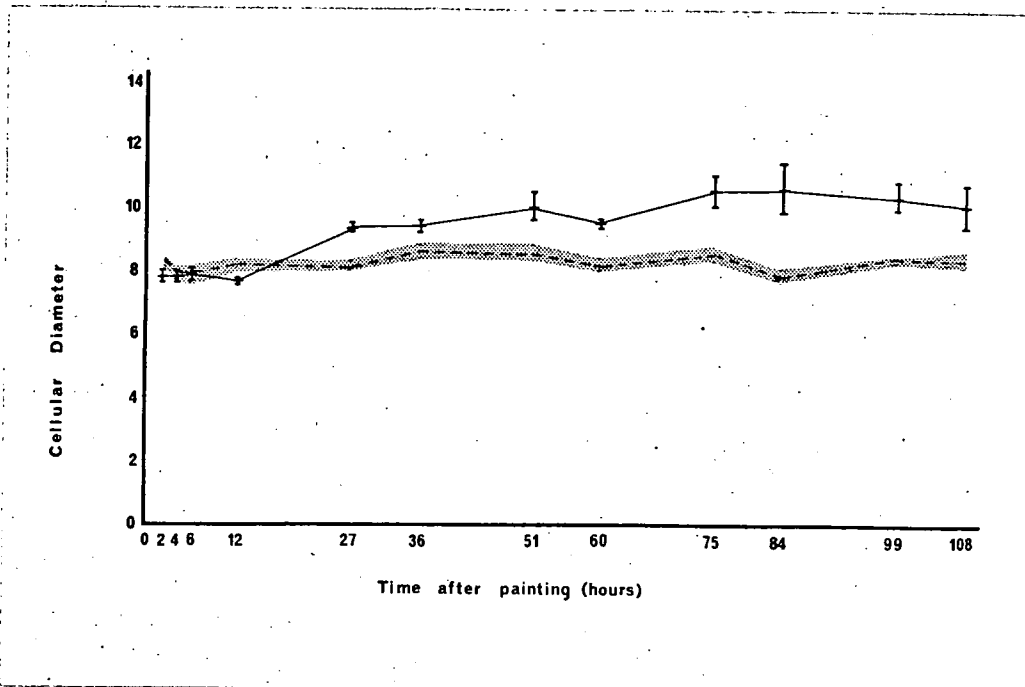

Pronounced cellular hypertrophy shown by measurements of apparent cellular diameter following a single application of methylcholanthrene.

Methylcholanthrene

The results are compared with the solvent controls in Figures 13-16. After treatment with this carcinogen, the epidermis responded with a slight reduction in thickness followed by a steady increase throughout the second and third days. The increase was then maintained on the fourth and fifth days. It has been shown that in the early stages this was largely due to hypertrophy, but on the fifty day a greater proportion is due to the hyperplasia which originated on the third day. These changes correlate very well with the level of cellular division. A depression in the mitotic index became apparent very soon after painting and after twenty-seven hours division was almost com-

TABLE 12

Epidermal Thickness (µm)

(Mean Values followed by 68 per cent Confidence Limits in Brackets)

<u>Time after Application (Hours)</u>	<u>Shaved Controls</u>	<u>MC</u>	<u>BA</u>	<u>AITC</u>
2	10.9 (10.5-11.3)	9.9 (9.2-10.7)	9.2 (8.6- 9.7)	10.6 (9.8-11.5)
4	9.8 (8.9-10.7)	9.6 (8.7-10.7)	8.3 (7.7- 9.0)	9.9 (9.2-10.7)
6	9.9 (9.3-10.5)	10.0 (9.2-10.8)	7.8 (7.5- 8.0)	9.9 (9.2-10.8)
12	10.4 (10.0-10.9)	8.9 (8.5- 9.4)	8.5 (8.2- 8.9)	10.9 (10.3-11.6)
27	9.0 (8.5- 9.6)	12.6 (11.9-13.3)	10.7 (9.8-11.6)	16.4 (15.3-17.6)
36	11.7 (11.1-12.3)	12.6 (11.7-13.6)	10.0 (9.5-10.7)	12.7 (11.8-13.6)
51	10.9 (10.0-11.8)	15.8 (14.8-16.8)	12.0 (11.4-12.5)	14.4 (13.8-15.0)
60	10.3 (9.7-11.0)	14.2 (13.1-15.5)	11.1 (9.7-12.6)	11.0 (10.4-11.7)
75	11.4 (10.9-11.9)	18.5 (16.5-20.7)	10.4 (9.9-11.0)	11.4 (10.6-12.2)
84	8.7 (8.2- 9.2)	17.0 (15.3-18.9)	11.6 (10.5-12.7)	11.5 (10.7-12.4)
99	10.3 (9.7-11.0)	18.3 (16.6-20.2)	10.1 (9.8-10.3)	10.7 (9.7-11.8)
108	10.1 (9.4-10.8)	17.5 (15.1-20.3)	10.7 (10.2-11.3)	9.2 (8.2-10.3)

MC - Methylcholanthrene BA- Benzanthracene AITC - Ally-iso-thiocyanate

TABLE 13

Mitotic Index

(Mean Values followed by 68 per cent Confidence Limits in Brackets)

<u>Time after Application (Hours)</u>	<u>Shaved Controls</u>	<u>MC</u>	<u>BA</u>	<u>AITC</u>
2	3.58 (3.17-4.00)	2.17 (1.24-3.09)	2.17 (1.61-2.72)	1.42 (0.98-1.85)
4	3.83 (2.85-4.81)	2.92 (2.09-3.75)	1.92 (1.46-2.37)	0.75 (0.50-1.00)
6	2.33 (1.75-2.92)	2.67 (2.34-2.99)	1.58 (1.08-2.09)	0.33 (0.17-0.50)
12	1.08 (0.81-1.36)	0.83 (0.54-1.13)	0.58 (0.43-0.74)	0.58 (0.09-1.07)
27	4.75 (3.76-5.74)	0.42 (0.26-0.58)	3.17 (2.69-3.64)	6.58 (4.99-8.18)
36	0.83 (0.45-1.21)	2.25 (1.79-2.71)	2.08 (1.41-2.76)	3.50 (2.30-4.70)
51	2.67 (2.39-2.95)	3.83 (2.53-5.14)	4.58 (3.36-5.80)	2.67 (2.21-3.13)
60	1.08 (0.88-1.28)	4.08 (3.23-4.93)	1.75 (1.33-2.17)	1.33 (0.91-1.76)
75	3.67 (3.11-4.22)	5.83 (4.20-7.46)	4.42 (3.96-4.87)	0.75 (0.19-1.31)
84	1.08 (0.93-1.24)	3.00 (2.27-3.73)	1.33 (1.12-1.54)	0.75 (0.42-1.09)
99	3.58 (2.99-4.18)	5.42 (4.46-6.37)	3.50 (3.16-3.84)	2.83 (2.55-3.11)
108	1.33 (0.93-1.74)	2.33 (1.87-2.80)	1.42 (1.06-1.77)	0.58 (0.43-0.74)

MC - Methylcholanthrene BA - Benzanthracene AITC - Ally-iso-thiocyanate

pletely blocked. Recovery was evident throughout the third day and on the last two days of sampling the index again assumed a precise rhythm although it was maintained at a higher value than normal. The similarity of the shape of the curves obtained for mitotic index and proliferation rate (Figure 17) would indicate a fairly constant value for the duration of division and this is demonstrated in Figure 18. It is possible that mitotic division was proceeding faster by the end of the fourth day and throughout the fifth.

Figure 17

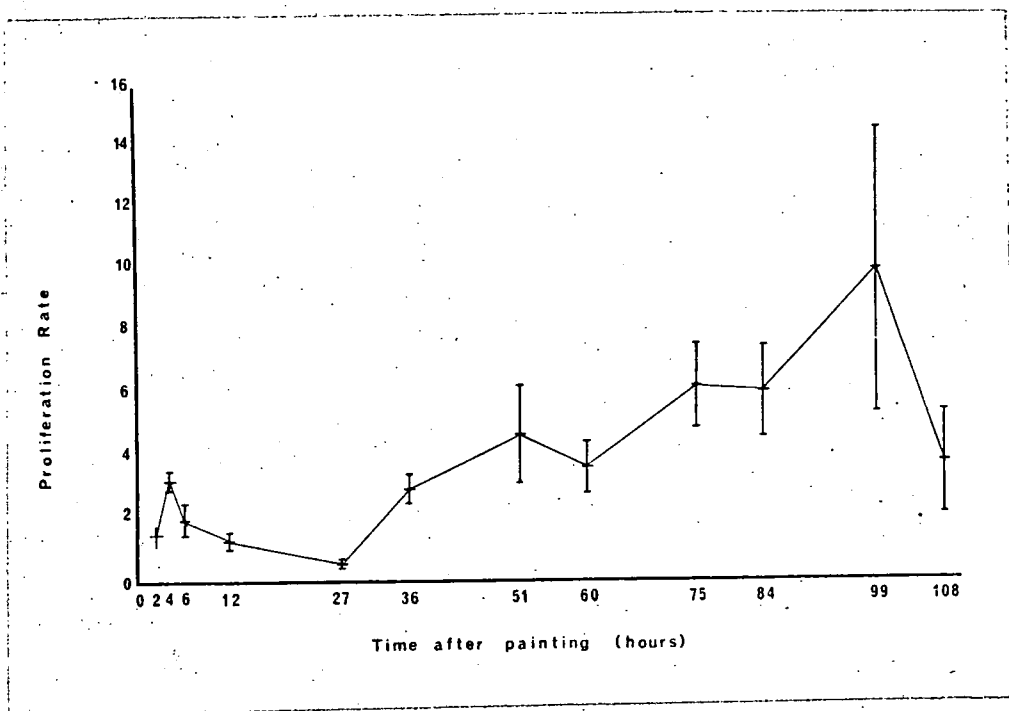

Changes in proliferation rate after a single application of methylcholanthrene. The mice were injected with colcemid three hours before sampling.

Figure 18

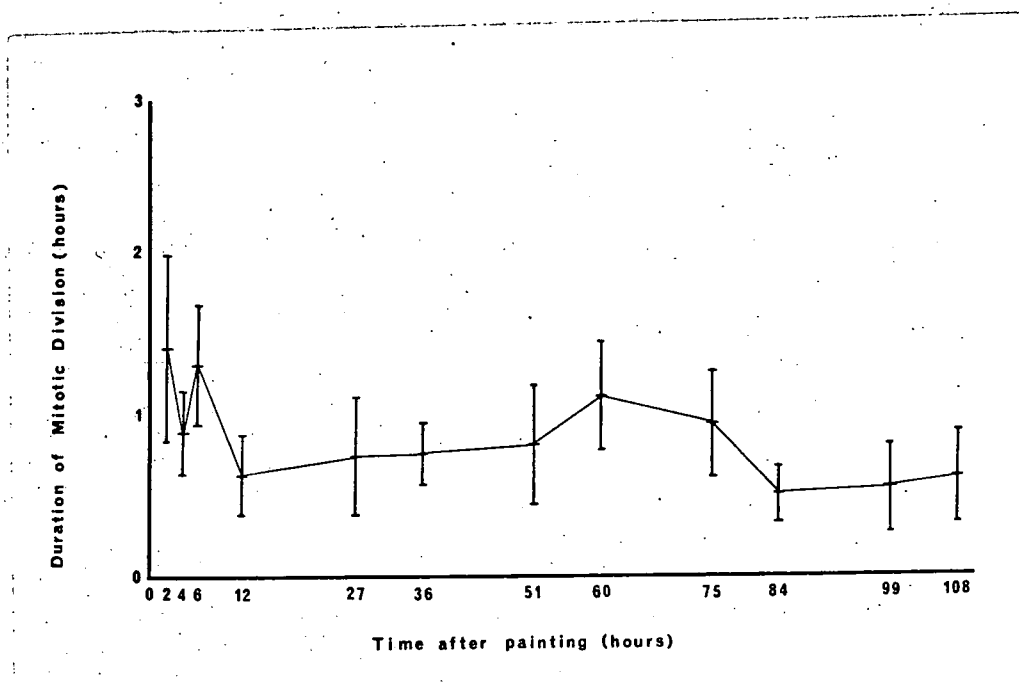

Changes in mitotic duration of the epidermal cells following a single application of methylcholanthrene. The duration was calculated from the mitotic index and the proliferation rate.

Benanthracene

The results are presented in Figures 19-22. Epidermal thickness was reduced for a few hours immediately after painting, but had begun to recover by the evening. This is reflected in the number of epidermal cells present. From the second day onwards these parameters showed very little variation from those of the controls. A very mild hyperplastic condition may have prevailed on day four ($p < 0.05$) but this level of significance results from an unusually low control value at this particular time. It is possible that the cells were somewhat enlarged after the first day, but even on the third day this was hardly significant ($p < 0.2$). The mitotic index was reduced throughout

the day of application, but had recovered by the next day. It reached a maximum on the third day; the mean value is one standard error greater than that of the shaved controls.

Figure 19

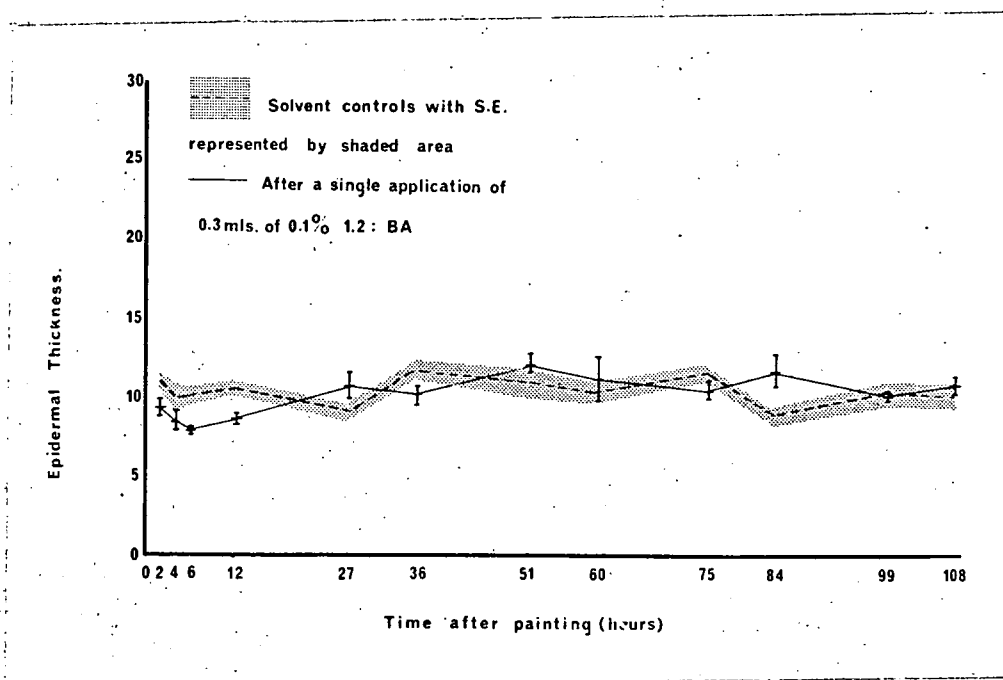

The effect of a single application of 300 μ g. of benzantracene on the thickness of the living layer of epidermal cells measured on a section perpendicular to the surface of the skin.

Figure 20

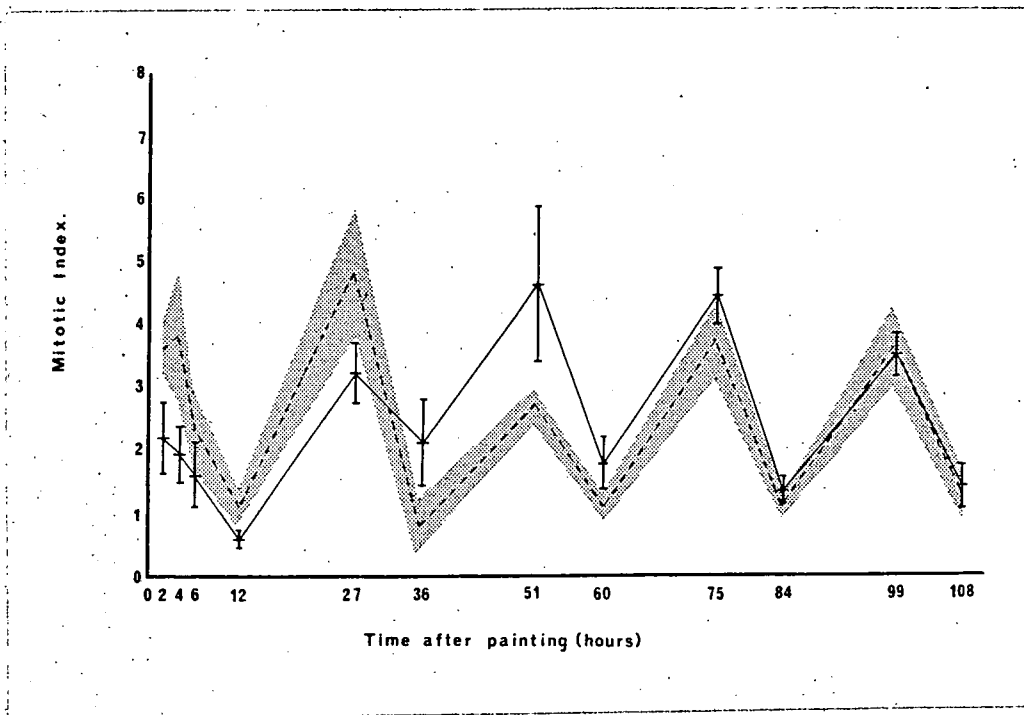

Variation in incidence of cellular division in the epidermis over the five days following a single application of benzanthracene.

Figure 21

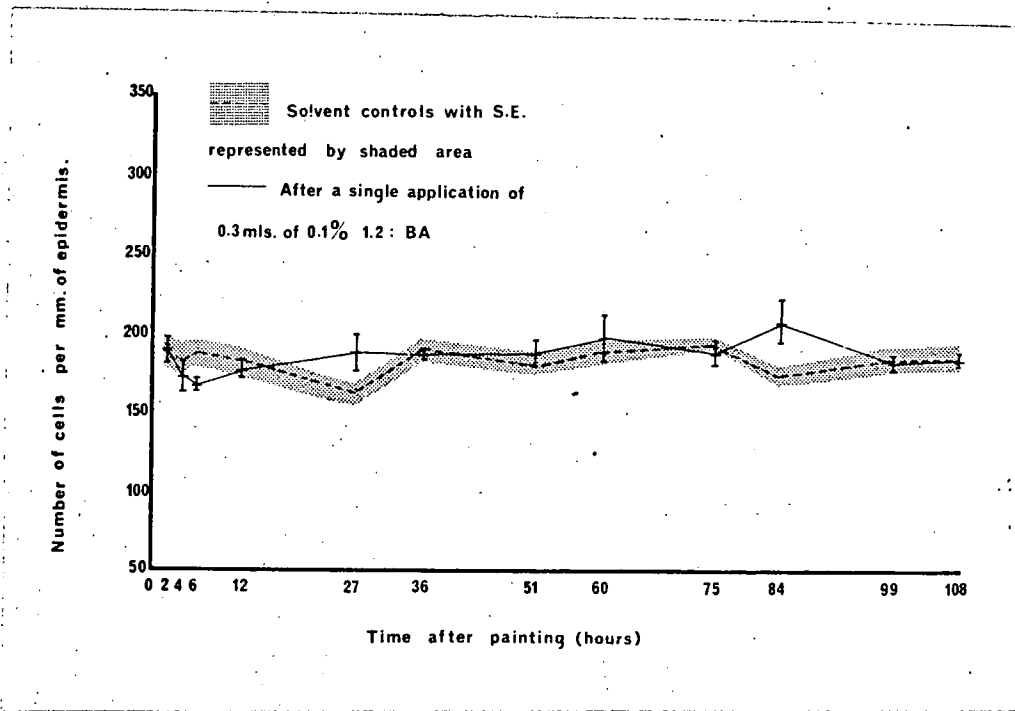

Changes in the epidermal cell population following a single application of benzanthracene.

Figure 22

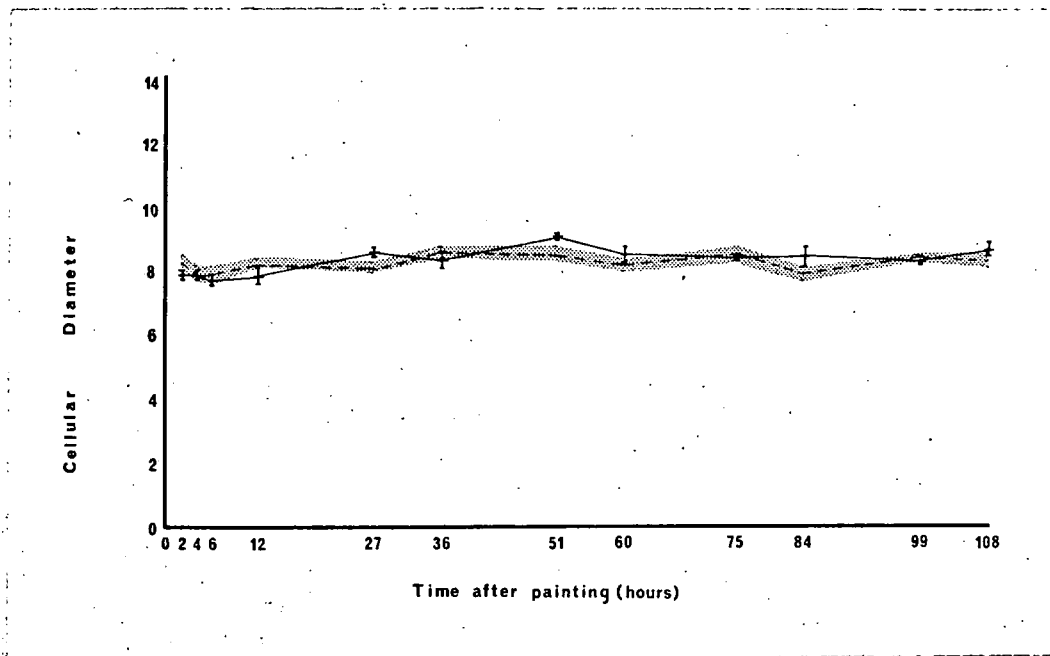

Variation in cell size over the five days following a single application of benzantracene. Note that this hydrocarbon did not produce hypertrophy.

Allyl-iso-thiocyanate

The results are presented in Figures 23-26. The epidermal thickness was significantly increased on the second and third days after painting and this increase was entirely due to enlargement of the squamous cells. No hyperplasia was evident at any time and there was a pronounced tendency for the number of cells to diminish after the third day.

TABLE 14

Number of Cells per Millimetre of Epidermis

(Mean Values followed by 68 per cent Confidence Limits in Brackets)

<u>Time after Application (Hours)</u>	<u>Shaved Controls</u>	<u>MC</u>	<u>BA</u>	<u>AITC</u>
2	202 (192-212)	208 (200-216)	189 (180-197)	181 (174-187)
4	197 (187-208)	200 (189-212)	171 (162-181)	174 (165-183)
6	201 (193-210)	202 (195-210)	166 (162-170)	172 (166-179)
12	195 (186-205)	191 (180-204)	175 (170-181)	187 (180-195)
27	173 (166-180)	184 (171-198)	186 (175-197)	196 (191-202)
36	201 (194-208)	182 (174-190)	186 (183-188)	178 (168-188)
51	189 (182-197)	195 (182-210)	186 (177-195)	197 (190-204)
60	195 (187-202)	203 (192-214)	196 (182-211)	173 (167-179)
75	199 (195-203)	211 (204-218)	187 (179-195)	176 (170-183)
84	177 (172-182)	189 (175-205)	207 (194-221)	176 (165-188)
99	185 (177-194)	214 (209-220)	186 (181-191)	172 (164-181)
108	186 (178-194)	220 (207-233)	183 (179-187)	170 (162-179)

MC - Methylcholanthrene BA - Benzanthracene AITC - Ally-iso-thiocyanate

TABLE 15

Cellular Diameter (μm)

(Mean Values followed by 68 per cent Confidence Limits in Brackets)

<u>Time after Application (Hours)</u>	<u>Shaved Controls</u>	<u>MC</u>	<u>BA</u>	<u>AITC</u>
2	8.3 (8.1-8.5)	7.8 (7.6- 8.0)	7.9 (7.7-8.0)	8.7 (8.4- 9.0)
4	7.9 (7.7-8.2)	7.8 (7.6- 8.0)	7.9 (7.7-8.0)	8.5 (8.4- 8.6)
6	7.9 (7.6-8.2)	7.9 (7.7- 8.1)	7.7 (7.6-7.9)	8.6 (8.2- 8.9)
12	8.2 (8.1-8.4)	7.7 (7.6- 7.8)	7.9 (7.7-8.1)	8.6 (8.4- 8.8)
27	8.1 (8.0-8.3)	9.3 (9.2- 9.5)	8.6 (8.4-8.7)	10.3 (10.1-10.6)
36	8.6 (8.4-8.8)	9.4 (9.2- 9.6)	8.3 (8.1-8.6)	9.5 (9.2- 9.8)
51	8.5 (8.3-8.8)	10.1 (9.7-10.6)	9.1 (9.0-9.2)	9.6 (9.5- 9.8)
60	8.2 (8.0-8.4)	9.5 (9.3- 9.6)	8.5 (8.2-8.8)	9.0 (8.7- 9.3)
75	8.5 (8.3-8.8)	10.6 (10.1-11.1)	8.4 (8.3-8.5)	9.1 (8.8- 9.3)
84	7.9 (7.7-8.1)	10.7 (9.9-11.5)	8.4 (8.1-8.8)	9.1 (8.9- 9.3)
99	8.4 (8.3-8.5)	10.4 (10.0-10.9)	8.3 (8.2-8.4)	8.9 (8.6- 9.2)
108	8.3 (8.1-8.6)	10.1 (9.4-10.7)	8.7 (8.4-8.9)	8.3 (8.0- 8.6)

MC - Methylcholanthrene BA - Benzanthracene AITC - Ally-iso-thiocyanate

Figure 23

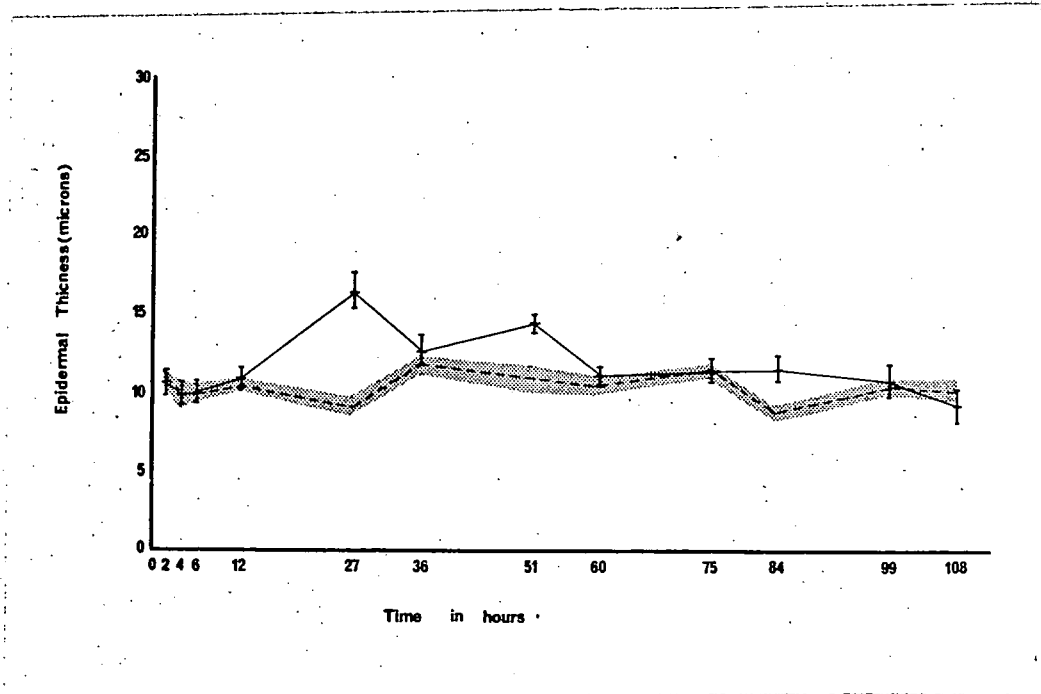

The effect of painting 15 μg . of allyl-iso-thiocyanate on the thickness of the epidermis compared with that of the pure solvent (acetone water, 9:1 by volume). The shaded area represents 1 standard error of the control.

Figure 24

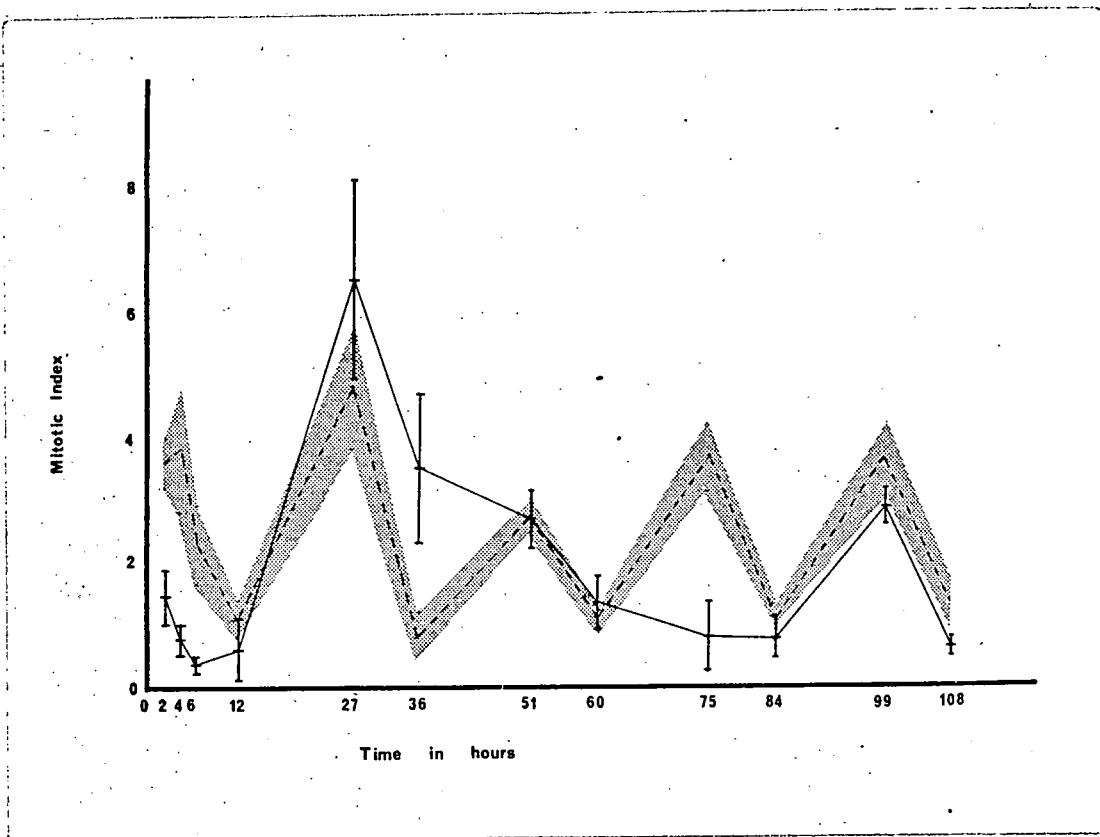

Variation in incidence of cellular division in the epidermis over the five days following a single application of allyl-iso-thiocyanate. Note the depression on the first and fourth days.

Figure 25

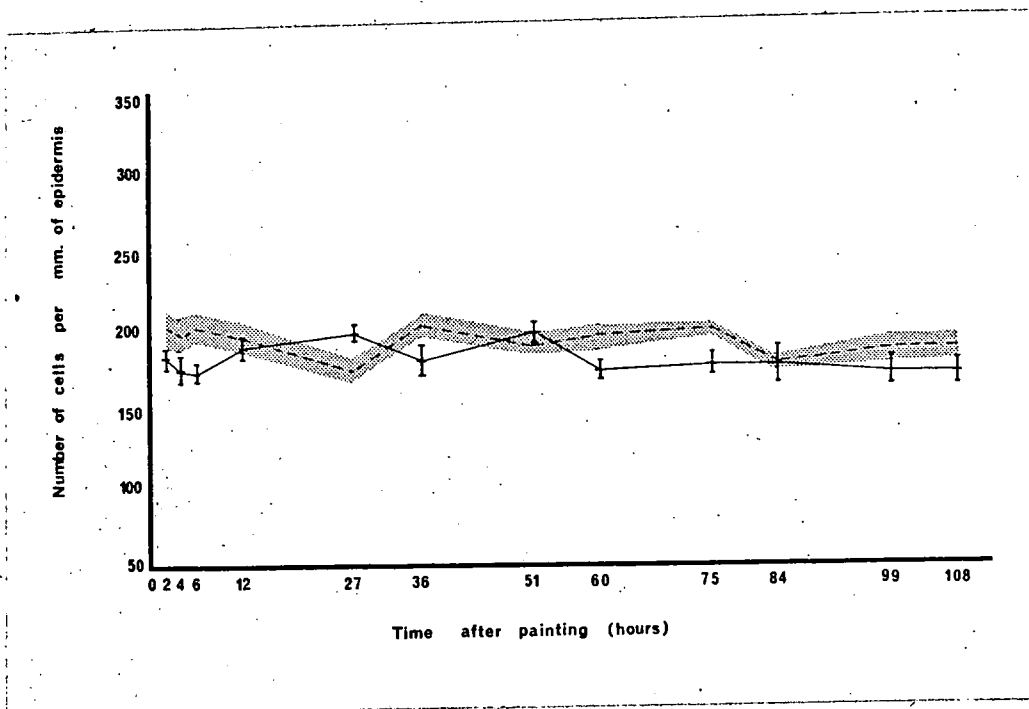

Changes in the epidermal cell population following a single application of allyl-iso-thiocyanate.

Figure 26

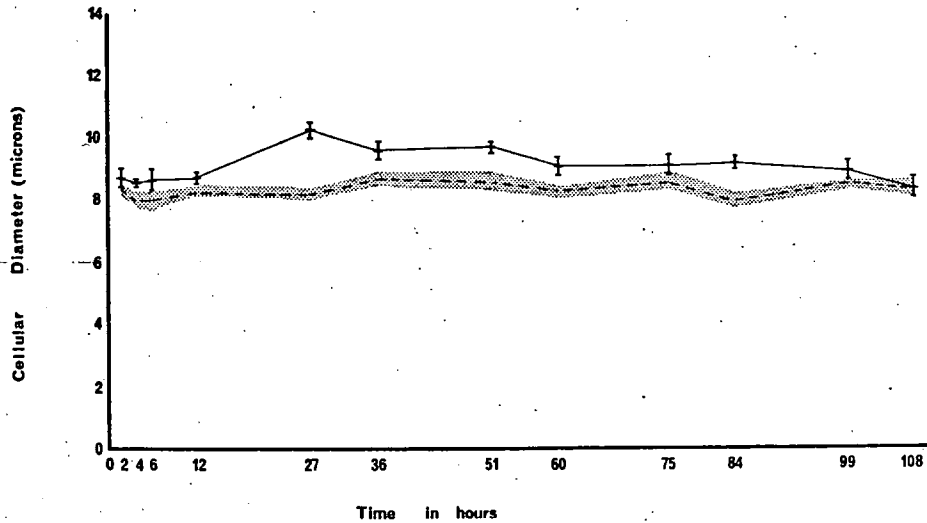

Variation in cell size after a single application of allyl-iso-thiocyanate. Note the hypertrophy from days two-four inclusive.

The treatment immediately reduced the level of cellular division for at least the first twelve hours. On the following day there were many mitotic figures, but in several of these the separate pieces of chromatin were contracted and this was especially evident in anaphase when the two arms of each chromosome did not appear to be extended towards the equator as they usually are. Pyknotic cells were seen adjacent to the basement membrane and a few had degenerated further and were karyolytic. The mitotic index was severely depressed on the fourth day. It is possible that so many of the cells from one phase of the proliferating section of the epidermis had been destroyed and insufficient daughter cells were prepared to divide until the next day when the

daily rhythm was resumed. An interesting feature of these results is that they resemble the variation of the mitotic index found after painting with the solvent. In both cases a high mitotic index on the morning of the second day was followed by a reduced count on the third day, and, although this was much less conspicuous with the latter, it could have resulted from a mild irritation.

TABLE 16

Incidence of Degenerate Cells and Abnormal Mitotic Figures in a Count of 12,000 Nucleated Epidermal Cells after AITC Treatment

<u>Time after Application (Hours)</u>	<u>Degenerate Cells</u>	<u>Atypical Mitoses</u>	<u>Invalid Mitoses</u>
2	16	2	0
4	38	0	0
6	39	0	0
12	87	0	0
27	94	0	0
36	110	1	0
51	56	1	0
60	39	0	0
75	20	0	0
84	36	0	0
99	10	3	0
108	29	0	0

DISCUSSION

There can be no doubt that the three substances examined in this section have very different effects upon the epidermal cell population. Application of methylcholanthrene or allyl-iso-thiocyanate is followed by an increase in epidermal thickness. In both cases it is apparent that this results more from changes in the size of the constituent cells than an increase in their number. The difference, however, lies in the persistence of these changes after treatment with the carcinogen. The increased thickness induced by allyl-iso-thiocyanate treatment is only a transitory response. Both of these compounds also produced marked changes in the proliferating compartment of the tissue. The difference in this case lies in the timing of the response. The irritant produced an immediate inhibition of cellular division whereas a delay of twenty-four hours occurred after methylcholanthrene treatment. At this time the epidermis which had been exposed to the irritant was in a very active state of cell production which would seem to agree with the hypothesis that this is a regenerative phenomenon in which the tissue is undergoing a state of self repair in response to cell damage. This is again confirmed by the high proportion of pyknotic and karyolytic cells observed at this time. A quantitative measurement was not made of the degenerate cells in the methylcholanthrene-exposed tissue, but qualitative examination suggested that the incidence was at no time higher than that of the control tissue. This is supported by quantitative findings with other carcinogens (Chapter 7). The reason for a second phase of

mitotic inhibition following allyl-iso-thiocyanate treatment is not clear. At this time the methylcholanthrene-exposed epidermis displayed a highly active state of cellular division with accompanying hyperplasia. This was not accompanied by a proportional increase in cellular degeneration and the new daughter cells appeared to be less hypertrophied and more normal in shape. These observations on samples taken a few days after exposure to the carcinogen are in agreement with those of many other workers (Frei and Stephens, 1968). There is a distinct impression that this latter phase is associated with a stimulation of mitosis rather than a regenerative mechanism.

There is no evidence to suggest that treatment with either methylcholanthrene or benzanthracene has influenced the duration of any of the phases of mitotic division (Figures 27-29). Berg (1948) discussed the contradictory reports on the relative incidence of the various phases and compared these with his own results in which benzanthracene treatment was followed by a very much reduced incidence of metaphase figures. Figure 28 demonstrated the rapidity with which the incidence of the various phase changes during the first thirty-six hours after the treatment and may help to explain the apparent contradictions which have led to confusion in the past.

Figure 27

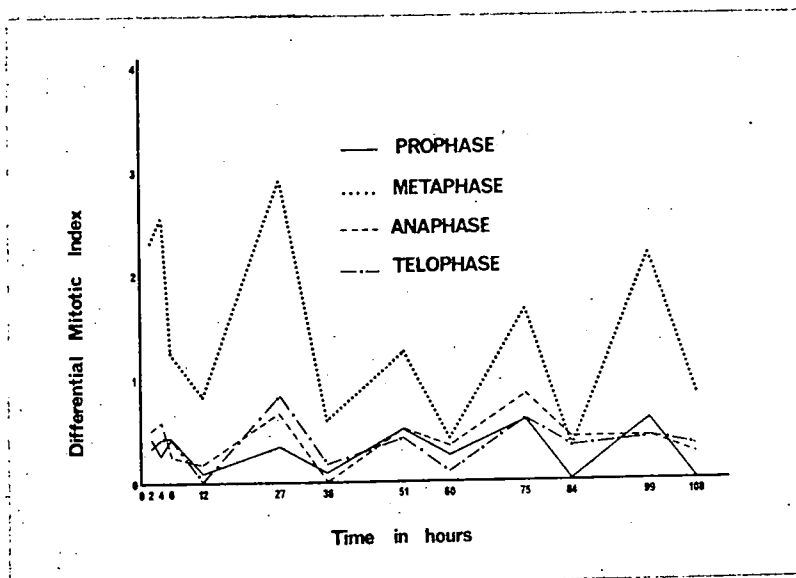

Variation in the various phases of mitosis in the epidermis following a single application of the pure solvent.

Figure 28

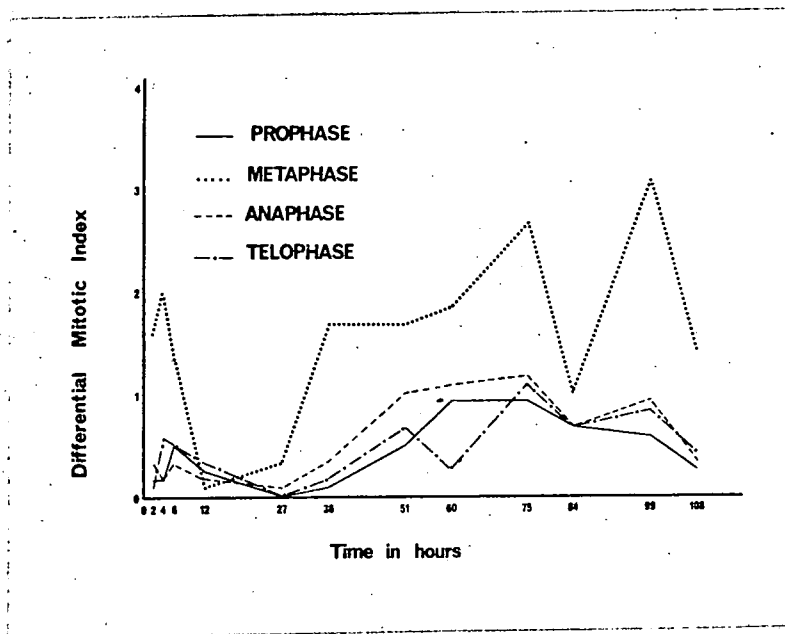

Incidence of the phases of cellular division over the five days following a single application of 0.1% methylcholanthrene in 90% aqueous acetone at 0 hours (08.30 hours G.M.T.). Since none of the phases occurs in unusually high proportion at any time, it would appear that the carcinogen does not interfere with the actual mechanism of mitosis.

Figure 29

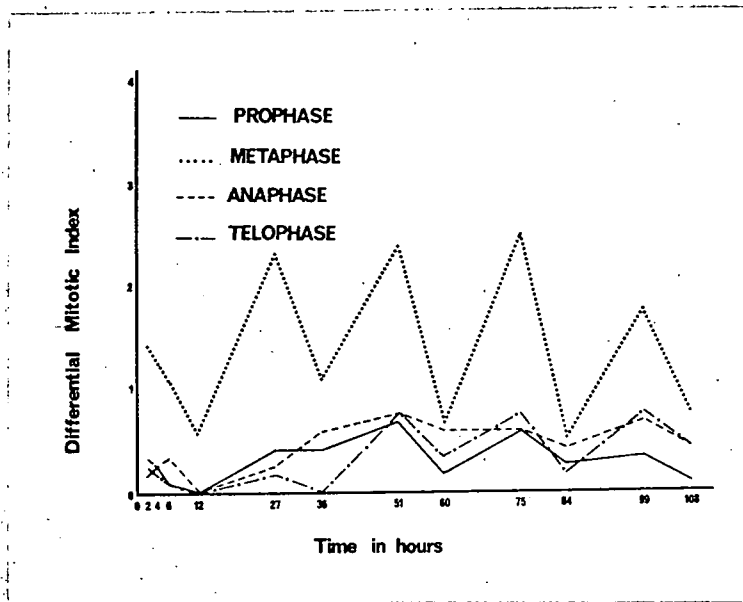

Incidence of the phases of cellular division over the five days following a single application of 0.1% benzanthracene in 90% aqueous acetone at 0 hours (08.30 hours G. M. T.).

The control observations suggest that the application of an acetone/water mixture is just as irritating as careful shaving. Because this slight response only became evident in an examination of the measurements and was not noticeable in the skin sections, it has been shown that this type of quantitative study is very valuable in detecting comparatively minor changes in the epidermis and obtaining information which may contribute to a better understanding of the cancer mechanism.

CONCLUSIONS

- (i) Treatment with the carcinogen brought about an increase in epidermal thickness which was still very much in evidence on the fifth day after exposure.



- (ii) This increase was due to both hyperplasia and hypertrophy, but the latter contributed more, especially in the earlier stages.
- (iii) Treatment with a non-carcinogenic irritant produced a transient increase in epidermal thickness which was entirely due to cellular hypertrophy.
- (iv) The non-carcinogenic hydrocarbon did not induce epidermal thickening.
- (v) All three test substances and the solvent vehicle had an appreciable affect upon the incidence of dividing cells in the epidermis. This was much less marked with benzanthracene treatment than the other two test substances. The pattern of change was very different between the carcinogen and the non-carcinogenic irritant.

CHAPTER 7

AN ATTEMPT TO CORRELATE EARLY EPIDERMAL CHANGES WITH THE TWO STAGE MECHANISM OF CARCINOGENESIS BY EXAMINING THE EFFECT OF A SINGLE PAINTING OF URETHANE AND COMPOUND A1

INTRODUCTION

Tumour regression
Initiation
Transformation
Co-carcinogenic promotion

METHOD

RESULTS

Urethane
Compound A1
Urethane followed by Compound A1

DISCUSSION

CONCLUSIONS

Persistent application of tar to the skin of mice induces papillomata to arise from the epidermis which are likely to regress if the treatment is stopped. After a much shorter period of tar painting the tumours reappear in the same place. They may also be induced to reappear by painting with turpentine or by wounding the previously painted area. There is no apparent histological difference between the area of epidermis which replaces a regressed papilloma and normal healthy epidermis (Rous and Kidd, 1941 and Mackenzie and Rous,

1941). These observations would suggest that some of the cells of the epidermis which replace the tumour are altered in some way, although they present a normal appearance and, in the presence of a suitable stimulus, they are capable of giving rise to a new papilloma.

Berenblum (1941) was interested in the effect of irritants upon the mouse epidermis. He found that croton oil, turpentine and xylene did not produce any appreciable increase in the tumour yield obtained with high dose levels of benzpyrene. With low dose levels however, he discovered that croton oil resin did produce an increased tumour yield. Since this was much greater than the sum of the tumours produced by these substances when painted separately, he concluded that the low dose level of benzpyrene initiated the cancer mechanism, but was incapable of bringing it to completion without the subsequent application of the croton oil, rather than a simple summation effect of two weak carcinogens. This was the first indication that the cancer mechanism might be divided into two stages. Berenblum considered high doses of benzpyrene to be capable of bringing about both these stages. Mottram (1944), using a similar type of test system, showed that a single application of a low dose of benzpyrene was sufficient to initiate latent tumour cells. In 1947, Berenblum and Shubik demonstrated that the initiation stage was irreversible and that the transformed cells remain dormant in the skin and do not gradually disappear. This was shown by delaying the start of the subsequent croton oil treatment when the latent

period was increased in proportion, but the tumour yield remained the same.

Much of the information concerning the initiation stage is theoretical. For instance, the existence of these transformed dormant cells has never been demonstrated and there is no experimental evidence which would exclude an overall tissue change. It is difficult to understand the persistence of transformed cells in a tissue such as the epidermis which is in a continual state of cell turnover. A few pure initiating agents are known. One of these is urethane (Salaman and Roe, 1953) which has been shown to initiate skin tumours although in the lung it is a total carcinogen (Nettleship and Henshaw, 1943). There is no record in the literature of any workers observing an epidermal response after treatment with urethane.

Conversely the response evoked by promoting agents is very marked and has been extensively studied. Croton oil is not a pure promoting agent because it is capable of producing a few tumours when painted alone. In 1968 Hecker and his colleagues succeeded in isolating a compound, 13 - acetyl phorbol 12 - myristate, from croton oil which they showed to be the active constituent. Before its identity was known they referred to it as compound A1. and this terminology became accepted in the literature. Other pure promoters are known, and the most important of these are the non-ionic detergents, known by the trivial names of Tween and Span. These have been investigated by Setala and his colleagues (1956 and 1957). All the known promoting agents produce a short term response which is characterised by

extensive epidermal hyperplasia and hypertrophy. This can also be evoked by treatment with irritants which are not carcinogenic, but it would not seem to be as persistent as that produced by the promoting agents. Such a condition also forms part of the response produced by many, if not all, of the carcinogenic polycyclic hydrocarbons as has been demonstrated with methylcholanthrene in the previous chapter. It has also been observed, however, after treatment with anti-carcinogens (Berenblum, 1929).

METHOD

In this section the initiator, urethane and the co-carcinogen A₁ were subjected to the test system developed in Chapter 5. In these experiments samples were not taken in the evening because the extra work involved did not seem to have provided any more valuable information in the cases already tested. The urethane was applied as a 20 per cent solution in 90 per cent aqueous acetone (i. e. single application of 60 mg.). In the following experiment 3.75 µg. of compound A₁ were applied in a single application of 0.3 ml. of solvent. If urethane behaves as a pure initiating agent and compound A₁ behaves as a pure promoting agent, then application of both these substances would be expected to produce tumours after prolonged exposure of the shaved skin. In order to determine whether the epidermal response to compound A₁ was modified by pretreatment with urethane, an experiment was performed in which the same quantity of compound A₁ was applied exactly seventy-two hours after a single application of 20 per

cent urethane. It was anticipated that any modification which was likely to occur might be very dependent upon the relative concentrations of the two compounds and the duration of the intervening period between applications. A period of seventy-two hours was chosen because previous experiments, such as the one involving treatment with methylcholanthrene had shown that the major disruptive changes, which had been observed and were therefore likely to occur in the epidermis, had all had a chance to operate by this time. The same dose volumes and concentrations were used so that the response could be compared directly with the parameters already determined.

RESULTS

The results obtained after treatment with both urethane and compound A₁ are compared with those already obtained in Figures 30-33. Numerical values are presented in Tables 17-20.

Urethane

On the day following treatment, the epidermis was considerably reduced in thickness, but on subsequent days, it gradually returned to normal and on the fifth day there was evidence to suggest that an almost imperceptible thickening was still in progress. The early reduction in thickness is explained by a very low cell population on two subsequent days and the later thickening is accounted for by a return to a normal population accompanied by a slight increase in the size of the squamous cells. The mitotic index was within normal control limits throughout the course of the experiments.

TABLE 17

Epidermal Thickness (µm)

(Mean Values followed by 68 per cent Confidence Limits in Brackets)

<u>Time after Application (Hours)</u>	<u>Urethane</u>	<u>Compound A</u>	<u>Combination</u>
3	9.8 (9.1-10.4)	10.4 (10.0-10.8)	11.9 (11.2-12.5)
27	7.7 (7.3- 8.2)	18.9 (18.0-19.8)	16.7 (15.1-18.5)
51	9.2 (8.6- 9.9)	21.4 (17.8-25.8)	20.6 (17.6-24.0)
75	10.2 (9.3-11.3)	22.3 (18.3-27.0)	21.9 (18.9-25.3)
99	11.7 (11.1-12.4)	21.3 (18.7-24.0)	16.3 (14.3-18.6)

TABLE 18

Mitotic Index

(Mean Values followed by 68 per cent Confidence Limits in Brackets)

<u>Time after Application (Hours)</u>	<u>Urethane</u>	<u>Compound A₁</u>	<u>Combination</u>
3	2.58 (2.18-2.98)	0.17 (0.06- 0.27)	0.75 (0.47- 1.02)
27	3.00 (2.61-3.39)	15.00 (11.63-18.37)	9.58 (8.49-10.67)
51	3.42 (3.09-3.75)	7.25 (5.89- 8.61)	6.17 (4.86- 7.48)
75	3.33 (2.89-3.77)	6.42 (5.37- 7.47)	7.50 (6.56- 8.44)
99	4.00 (3.14-4.86)	6.83 (5.82- 7.84)	3.58 (2.57- 4.59)

TABLE 19

Number of Cells per Millimetre of Epidermis

(Mean Values followed by 68 per cent Confidence Limits in Brackets)

<u>Time after Application (Hours)</u>	<u>Urethane</u>	<u>Compound A₁</u>	<u>Combination</u>
3	178 (175-181)	176 (170-183)	206 (198-215)
27	155 (151-160)	198 (190-206)	205 (194-216)
51	158 (150-165)	231 (212-251)	235 (223-251)
75	184 (175-193)	260 (234-289)	266 (248-285)
99	187 (175-199)	266 (250-283)	225 (211-240)

TABLE 20

Cellular Diameter (μm)

(Mean Values followed by 68 per cent Confidence Limits in Brackets)

<u>Time after Application (Hours)</u>	<u>Urethane</u>	<u>Compound A1</u>	<u>Combination</u>
3	8.4 (8.1-8.6)	8.7 (8.6- 8.7)	8.6 (8.3- 8.9)
27	8.0 (7.8-8.1)	11.0 (10.7-11.4)	10.2 (9.7-10.7)
51	8.6 (8.4-8.9)	10.9 (10.2-11.6)	10.6 (10.0-11.1)
75	8.4 (8.2-8.7)	10.5 (10.0-11.0)	10.2 (9.8-10.7)
99	8.9 (8.8-9.1)	10.1 (9.7-10.5)	9.6 (9.3-10.0)

Figure 30

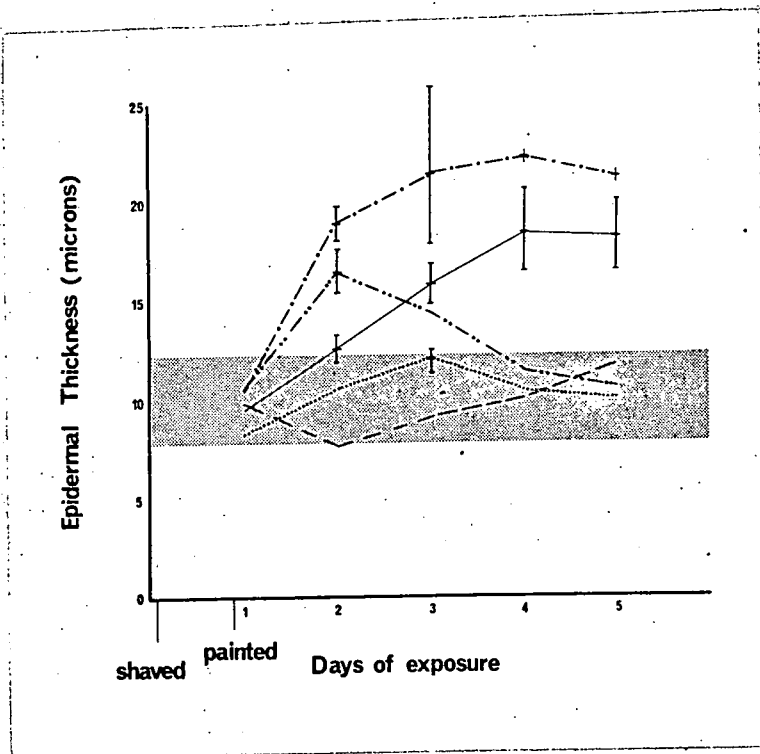

Comparison of the effect of a single application of various substances on the thickness of the living layer of epidermal cells measured on a section perpendicular to the surface of the skin. For key see Figure 31.

Figure 31

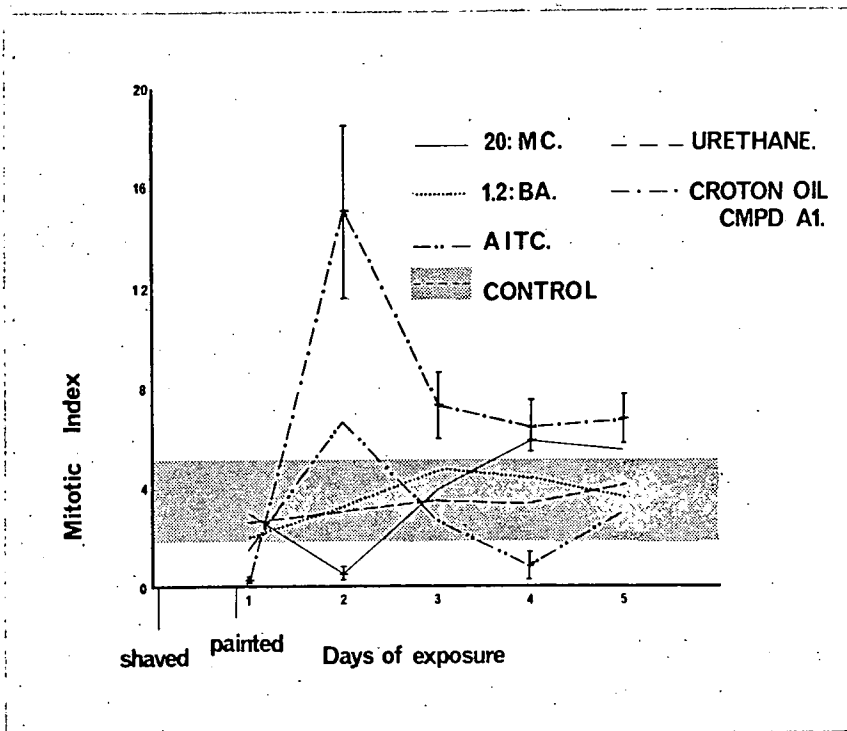

Comparison of the effect of a single application of various substances on the incidence of mitosis at 11.30 hours G. M. T. on the first five days of exposure. The boundaries of the shaded area represent deviations of 2. S. E. from the mean calculated from all results obtained from normal, shaved and solvent treated mice at this time of day.

Figure 32

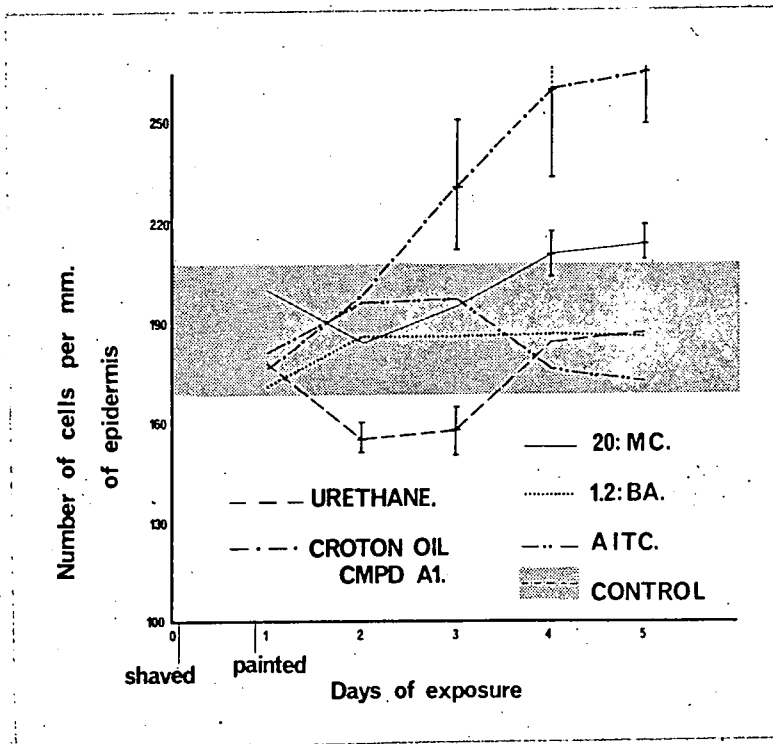

Comparison of the effect of a single application of various substances on the epidermal cell population.

Figure 33

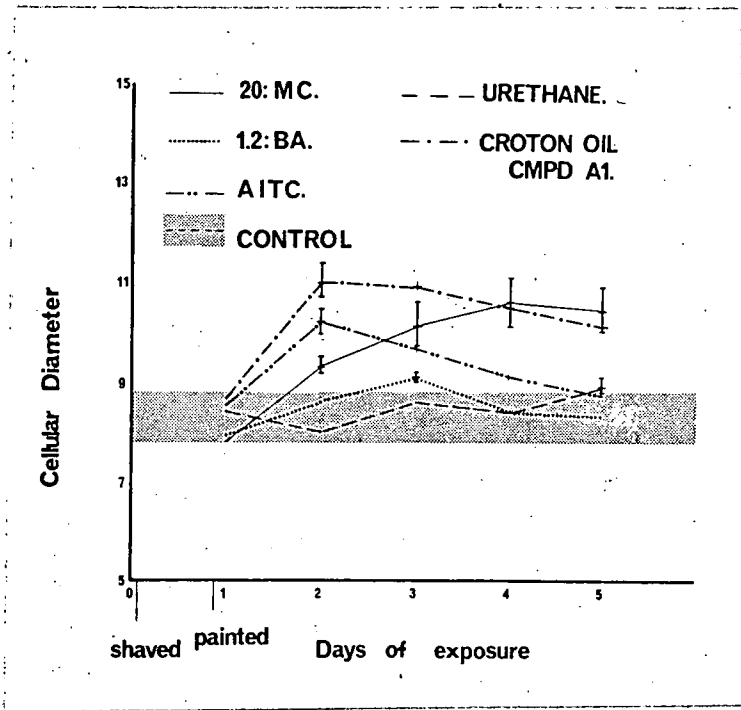

Comparison of the effect of a single application of various substances on the apparent size of the epidermal cells.

Compound A₁

Treatment was followed almost immediately by an increase in the size of the cells, but the epidermal thickness remained unaltered because of a slight drop in cell population. This was probably caused by a temporary inhibition of cellular division since the mitotic index was almost negligible. On subsequent days there was a dramatic increase in all parameters. On the day following treatment mitotic figures were incredibly abundant as if they had been arrested for a long period with colchicine but all phases were present and appeared to be normal. The mitotic index was the highest ever recorded in

this series of experiments. On subsequent days it was much reduced, but still significantly higher than the control value ($p < 0.001$). This intense cellular proliferation led to a progressive increase in the number of epidermal cells which still persisted on the last day of sampling and was accompanied by an increased thickness. Maximum thickness was achieved on the fourth day, the reduction on the following day being associated with a gradual loss of hypertrophied cells. Distortion of the cells was most apparent on the day after treatment and thereafter the cells became progressively smaller. Presumably only those cells which were formed during the first twenty-four hours after treatment were affected in this way and they were gradually lost by differentiation and exfoliation from the surface.

Urethane followed by Compound A₁

The results obtained are compared with those obtained for urethane and compound A₁ in Figures 34-37.

Figure 34

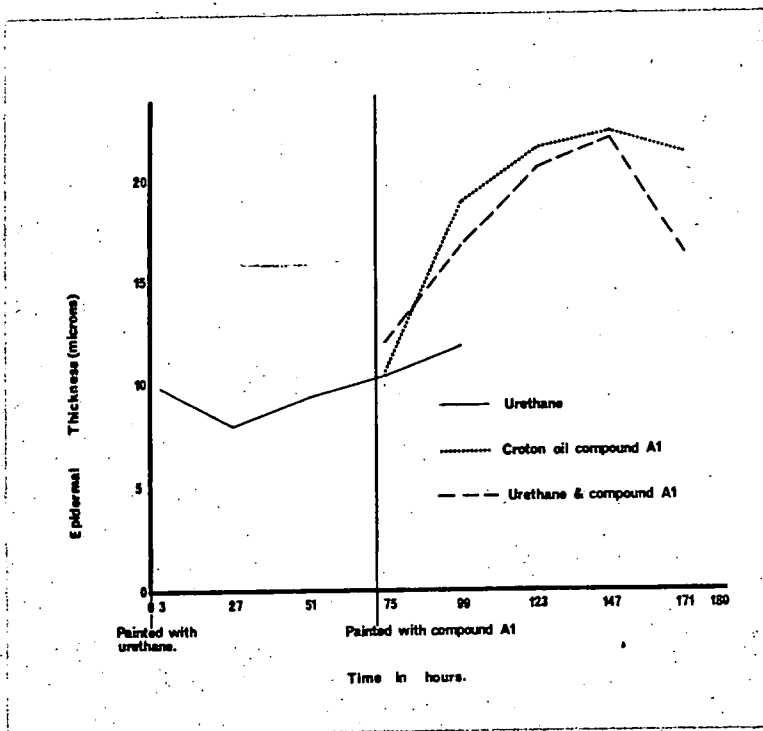

Effect of the combination on epidermal thickness

TABLE 21

Incidence of Degenerate Cells and Abnormal Mitotic Figures
in a Count of 12,000 Nucleated Epidermal Cells

Time after Application (Hours)	Urethane			Compound A1			Combination		
	D	A	I	D	A	I	D	A	I
3	0	2	2	18	1	0	17	1	0
27	4	4	0	2	13	2	14	3	0
51	4	4	0	3	3	0	9	6	1
75	10	7	0	1	1	0	16	1	0
99	8	4	2	9	0	0	11	0	0

D = Degenerate cells A = Atypical Mitoses I = Invalid Mitoses

Figure 35

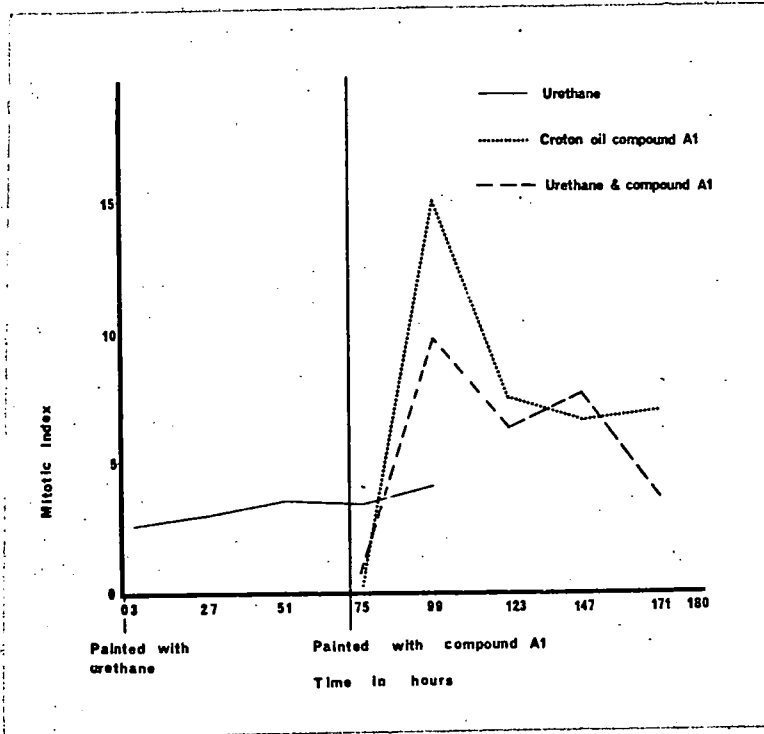

The effect of a combination of urethane and compound A₁ on the incidence of cellular division in the epidermis. Note the reduced level of division ninety-nine hours after the start of the experiment.

Figure 36

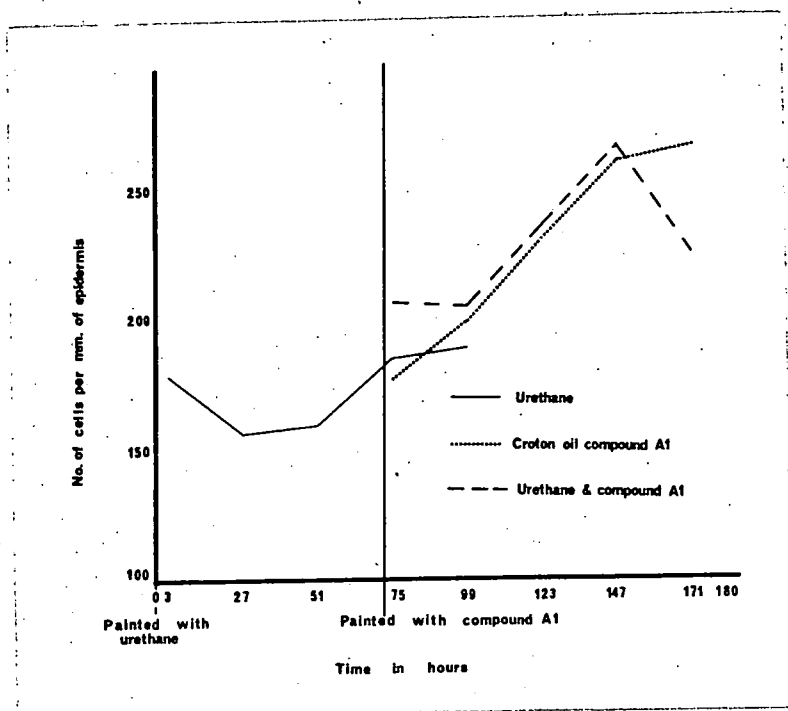

The effect of a combination of a weak initiator and a powerful co-carcinogenic promoter on the epidermal cell population.

Figure 37

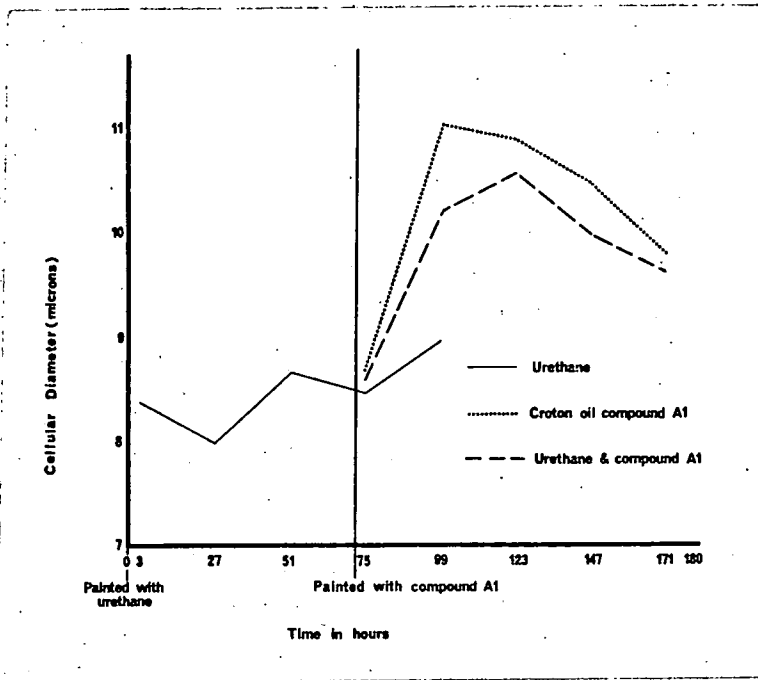

The effect of a combination of urethane and compound A₁ on the apparent size of the epidermal cells compared with that of each of these substances separately.

On the day following the application of compound A₁, the mitotic index had again risen dramatically, but only just over half as much as that following compound A₁ alone. The difference is not significant, however, ($p < 0.2$). On the fifth day the index returned to normal. This modification was also reflected in the epidermal thickness and the number of squamous cells, the values of which were both decreasing rapidly on the last day of sampling. It is interesting to note that the number of cells in the epidermis was much higher ($p < 0.02$) three hours after subsequent treatment with compound A₁ than it had been after application of this substance on its own.

DISCUSSION

Treatment with urethane is followed by a transient hypoplasia of the epidermal cell population. Whether this is a general characteristic of initiating agents remains difficult to prove in the absence of other members of this class which can be shown to be definitely devoid of promoting properties. The mechanism by which this hypoplastic state is induced also remains somewhat obscure. It could result from an abnormal loss of cells by surface exfoliation. Alternatively, it might be associated with a change in the rate of cellular division. An increase in the duration of mitosis with a proportional decrease in the dividing population would show an apparently normal mitotic index at any instant of time, but would result in a reduction in the cell population.

The absence of any noteworthy cellular degeneration coupled with the very high incidence of cellular division following treatment with compound A₁ suggests that the changes observed are not associated with a regenerative response. The persistence of the hyperplastic response is very notable and is strongly reminiscent of the response following methylcholanthrene treatment. When treatment was preceded by application of urethane, the hypertrophy which was most apparent on the day after dosing, did not reach a maximum until the next day. This might indicate that the initiating effect operates by subduing early changes so that if the potency of the initiating agent could have been greatly increased, the response would tend more to

resemble that shown by methylcholanthrene.

Correlation of 'somatic mutations', expressed as atypical or invalid mitotic figures, with initiating activity is certainly not evident (Table 21). This may be because the numerical values are too small, but, since each represents the value obtained from a count of 12,000 nuclei, a more reliable value would necessitate an enormous amount of cell counting.

Recent work (Oehlert and Grimm, 1966; Hecker and Paul, 1968) using tritium labelled carcinogenic hydrocarbons suggests that there is some reaction between these and the cellular constituents of the epidermis very shortly after administration, and that this reaction may be completed in about the first twenty-four hours. The evidence also suggests that the reaction products remain in the epidermis for at least seventy-two hours and they are then gradually eliminated over the next eight days. Investigations of the synthesis of DNA and RNA (Paul, 1969) after administration of hydrocarbons and compound A₁ suggest that synthesis is interrupted by carcinogens during the twenty-four hours following treatment and this is followed by stimulation, whereas the promoting agent stimulates synthesis without a preliminary inhibition. Stimulation of DNA synthesis continued for up to seventy-two hours. The duration and timing of the various aspects of the response obtained with urethane, compound A₁ and methylcholanthrene are in very good agreement with the observations of these workers.

CONCLUSIONS

- (i) Application of the initiator was followed by a reduction in the thickness of the epidermis which was entirely due to a diminished population of cells.
- (ii) Application of the co-carcinogenic promoter resulted in massive epidermal thickening due to both hyperplasia and hypertrophy. In addition, the incidence of cellular division was extremely pronounced.
- (iii) The visible changes associated with the initiator were completed in the first three days. The changes associated with the promoter were still very much in evidence on the fifth day after exposure.
- (iv) Cellular degeneration and chromosome aberrations occurred very seldom and could not be correlated with either type of treatment.

CHAPTER 8

AN INVESTIGATION OF THE RESPONSE PATTERNS OF SEVERAL MORE EXAMPLES OF EACH CLASS OF ACTIVITY AND THE SUBSEQUENT DEVELOPMENT OF A SCREENING TEST FOR CARCINOGENS AND COCARCINOGENS

INTRODUCTION

METHOD

SUBSTANCES TESTED

A. Polycyclic aromatic hydrocarbons

- 9.10 - Dimethyl 1.2 - benzanthracene
- 3.4 - Benzpyrene
- 1.2.5.6. - Dibenzanthracene
- 1.2.7.8. - Dibenzanthracene
- 1.2.3.4. - Dibenzanthracene
- 20 - Methylcholanthrene

B. Nitrogen Heterocyclics

- Tricycloquinazoline
- Acridine

C. Miscellaneous substances

- Cantharidin
- Croton oil

ANALYSIS AND INTERPRETATION OF THE RESULTS

DISCUSSION

CONCLUSIONS

The series of experiments described in this section were carried out with the object of determining whether the features of the epidermal response were characteristic of the various classes of activity under

investigation and whether particular aspects could be specifically associated with carcinogenic or cocarcinogenic substances. As the work progressed, it became evident that there were correlations between the activity of the test substances and the response patterns which were beginning to emerge. These patterns were analysed into distinctive features and a short term test was developed.

METHOD

Essentially the same test system was used, but, in order to increase the number of substances which could be tested, sampling was carried out on the first, second and fourth days only, because the most important changes in mitotic index had been observed at those times. In addition, an examination of the samples taken previously showed that six mice per group produced very little more information than a sample of four. In each experiment twelve mice, which had been shaved on the previous day at 10.00 hours, were painted with a solution of the test substance at 08.30 hours. These were divided into three groups which were sampled three, twenty-seven and seventy-five hours after treatment.

EXPERIMENTS AND RESULTS

A. Polycyclic Hydrocarbons

9.10 -- Dimethyl 1,2 --Benzanthracene (DMBA), 300 µg.

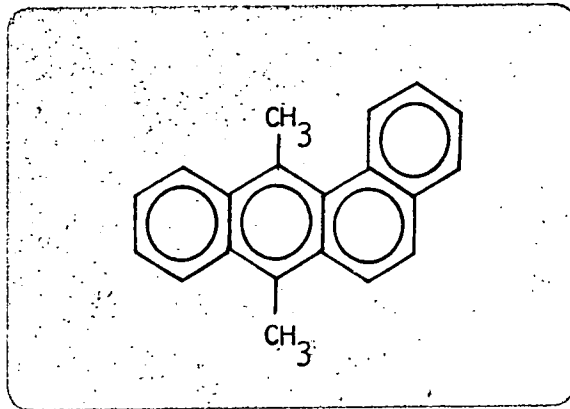

It is well established that this is a very potent carcinogen (Burrows, Roe and Schober, 1945). Application was followed, initially by a slight rise in mitotic index, but on the following day cellular division was strongly inhibited. Four days after treatment, the mitotic index was slightly lower than normal and accompanied by a reduced cell population, possibly indicating some irritant activity. The most striking aspect of the response on this day was the enormous enlargement of the cells which gave rise to an abnormally thickened epidermis.

TABLE 22

	<u>Epidermal Thickness</u>	<u>Mitotic Index</u>	<u>Number of Cells</u>	<u>Cellular Diameter</u>	<u>Dead Cells</u>
Day 1	-	4.50	-	-	0.13
Day 2	10.7	0.75	177	8.8	3.13
Day 4	19.2	2.38	167	12.1	6.25

3.4 - Benzpyrene (BP), 300 µg.

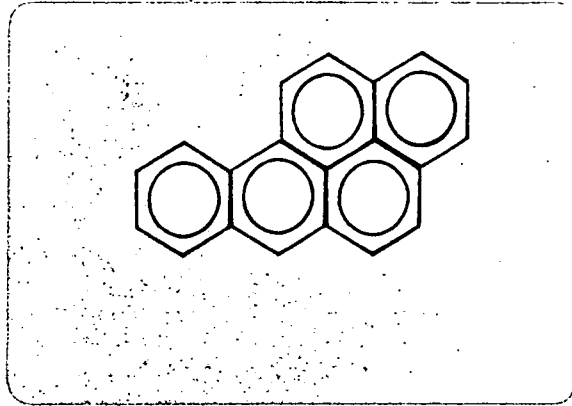

This is another highly potent carcinogen (See Chapter 3). The response was very similar to that obtained after methylcholanthrene.

TABLE 23

	<u>Epidermal Thickness</u>	<u>Mitotic Index</u>	<u>Number of Cells</u>	<u>Cellular Diameter</u>	<u>Dead Cells</u>
Day 1	-	2.00	-	-	1.00
Day 2	10.1	0.13	150	9.3	1.38
Day 4	14.2	4.25	189	9.8	2.50

1.2.5.6. - Dibenzanthracene (DBA), 300 µg.

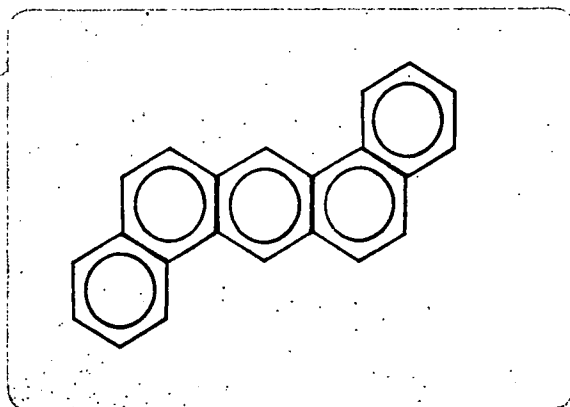

This is another standard carcinogen used in cancer testing. Its activity is less than methylcholanthrene, dimethylbenzanthracene and benzpyrene (Pullinger, 1945). On the day after treatment hyperplasia was evident and this was accompanied by a reduction in the mitotic index. This reduction was not as marked as has been observed with methylcholanthrene, dimethylbenzanthracene or benzpyrene and this may reflect the lower activity of 1.2.5.6. - dibenzanthracene. Cellular hypertrophy and an increased mitotic index were evident on the fourth day. This response pattern is of particular interest since it is possible to distinguish similarities to the separate patterns observed after treatment with urethane and compound A₁; hypoplasia, twenty-seven hours after treatment is followed by an increased mitotic index and cellular hypertrophy seventy-five hours after treatment.

TABLE 24

	<u>Epidermal Thickness</u>	<u>Mitotic Index</u>	<u>Number of Cells</u>	<u>Cellular Diameter</u>	<u>Dead Cells</u>
Day 1	-	3.25	-	-	1.13
Day 2	10.3	2.88	164	8.9	1.00
Day 4	11.0	6.63	164	9.2	1.00

1.2.7.8. - Dibenzanthracene, 300 µg.

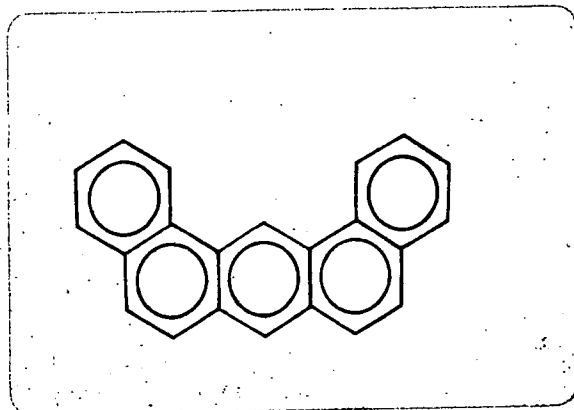

Its activity is equivocal since it has not been examined very thoroughly. Barry, Cook, Haselwood, Hewett, Hieger and Kennaway (1935) found one malignant and three benign tumours in the skin of twenty mice. After an initial depression, the mitotic index rose considerably higher than normal. The comparatively low cell population on the second day is not in agreement with the high mitotic index. Hypertrophy was evident on the fourth day.

TABLE 25

	<u>Epidermal Thickness</u>	<u>Mitotic Index</u>	<u>Number of Cells</u>	<u>Cellular Diameter</u>	<u>Dead Cells</u>
Day 1	-	2.50	-	-	1.38
Day 2	10.1	6.88	180	8.5	0.63
Day 4	12.0	4.63	170	9.5	0.88

1.2.3.4. - Dibenzanthracene, 300 µg.

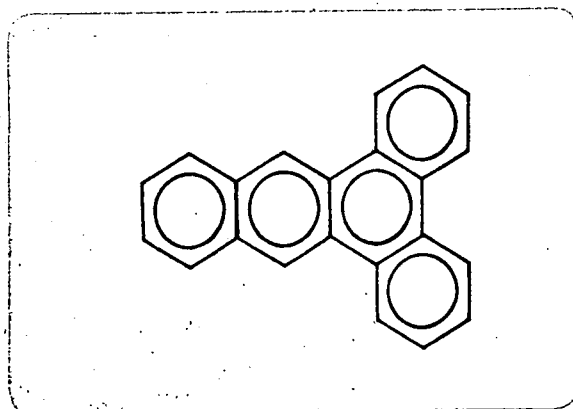

This has been painted very seldom and then only with small numbers of mice. Cook, Heiger, Kennaway and Mayneord (1932) produced two tumours, but the purity of the sample was uncertain. Barry, Cook, Haselwood, Hewett, Heiger and Kennaway (1935), with the pure compound, produced no tumours in twenty mice 487 days after the beginning of treatment. In this case, the anomaly between the number of epidermal cells and the mitotic index on the second day was even more evident. On the fourth day, although the mitotic index was at its highest and well above the normal range, the cell population remained very low. Hypertrophy was again evident on the fourth day.

TABLE 26

	<u>Epidermal Thickness</u>	<u>Mitotic Index</u>	<u>Number of Cells</u>	<u>Cellular Diameter</u>	<u>Dead Cells</u>
Day 1	-	3.25	-	-	2.13
Day 2	9.2	4.25	157	8.6	2.50
Day 4	10.6	5.13	168	9.0	1.75

20 - Methylcholanthrene, 150 µg.

The response was almost identical to that obtained at the higher dose level (see Chapter 5).

TABLE 27

	<u>Epidermal Thickness</u>	<u>Mitotic Index</u>	<u>Number of Cells</u>	<u>Cellular Diameter</u>	<u>Dead Cells</u>
Day 1	-	4.38	-	-	0.50
Day 2	11.1	0.50	165	9.2	2.25
Day 4	14.8	8.50	176	10.4	1.13

B. Nitrogen Heterocyclics

Tricycloquinazoline (TCQ) 25.8 µg.

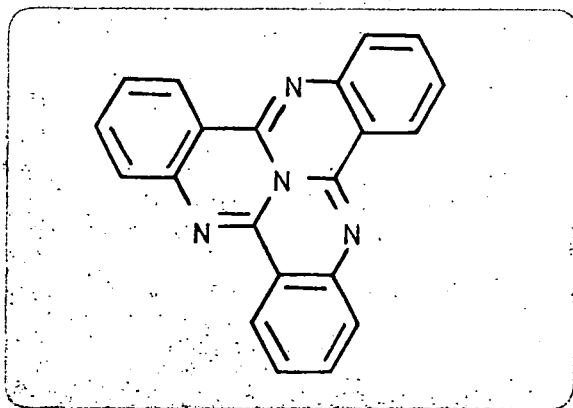

300 µg. applied twice weekly produced malignant tumours in twenty-six mice out of a total of thirty-six after 280 days (Baldwin, Cunningham and Partridge, 1959). This compound is, therefore, highly carcinogenic. Unfortunately, its solubility in the acetone-water mixture was very limited and this was the highest dose which could be applied without altering the standard experimental conditions. There appeared to be a slight elevation in the mitotic index three hours after treatment and on the following day this had become significant. Conversely, the cell population was considerably reduced and a marked hypoplasia was apparent. Cellular hypertrophy was not detected at any time and on the fourth day the mitotic index had fallen to normal.

TABLE 28

	<u>Epidermal Thickness</u>	<u>Mitotic Index</u>	<u>Number of Cells</u>	<u>Cellular Diameter</u>	<u>Dead Cells</u>
Day 1	-	4.38	-	-	0.50
Day 2	9.5	5.50	153	8.9	0.63
Day 4	10.4	3.00	176	8.7	2.00

Acridine, 300 µg.

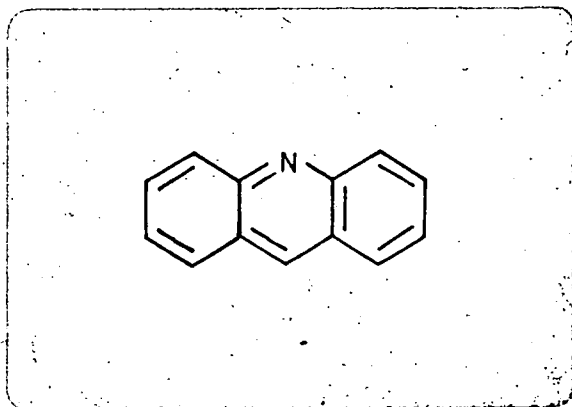

This compound is not known to have produced any skin tumours although it has often been tested, (Kennaway, 1924 a, b and c.). It is generally regarded as a non-carcinogenic irritant.

TABLE 29

	<u>Epidermal Thickness</u>	<u>Mitotic Index</u>	<u>Number of Cells</u>	<u>Cellular Diameter</u>	<u>Dead Cells</u>
Day 1	-	2.38	-	-	1.38
Day 2	10.5	2.75	192	8.4	2.00
Day 4	8.6	2.63	158	8.3	2.38

The mitotic index was slightly lower than normal on each day and this probably accounts for the significantly reduced cell population ($p < 0.01$) on the fourth day. Hyperplasia and hypertrophy were not observed throughout the course of the experiment.

C. Miscellaneous Substances

Cantharidin, 60 µg.

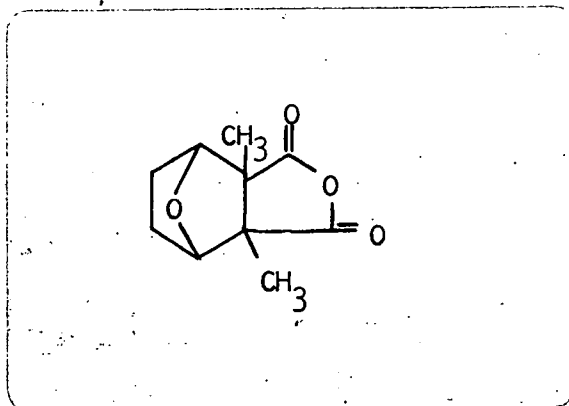

This is a very powerful skin irritant. It was shown to be non-carcinogenic by Orr (1938), to reduce the carcinogenicity of tar by Berenblum (1935), to have no promoting activity by Gwynn and Salaman (1953) and to have no initiating activity by Roe and Salaman (1955). This dose level was found to be the highest non-lethal dose, indicating that it is much more toxic in this strain of mice than in the hairless mice (Elgjo, 1966). An elevated mitotic index on the day following treatment was accompanied by a significant increase in the number of degenerate cells. Cellular hypertrophy was evident on the second and fourth days, but the cell population did not show any appreciable fluctuations. The mitotic index had returned to normal by the fourth day.

TABLE 30

	<u>Epidermal Thickness</u>	<u>Mitotic Index</u>	<u>Number of Cells</u>	<u>Cellular Diameter</u>	<u>Dead Cells</u>
Day 1	-	3.38	-	-	2.22
Day 2	14.3	7.00	186	9.9	5.50
Day 4	12.3	3.75	189	9.1	2.25

Croton Oil, 300 µg.

The promoting activity of croton oil is well known (See Chapter 7). Through the kind co-operation of Mr. B. C. V. Mitchley, a sample of proved activity was obtained from the Chester Beatty Research Institute.

Three hours after treatment, mitotic activity was almost completely inhibited. On the second day the epidermis was found to be in a very active state of division with an increased cell population and much hypertrophy. Two days later mitotic activity was not so pronounced, although it had not returned to normal. An even larger population of cells was evident, but a greater proportion of these were of normal size.

TABLE 31

	<u>Epidermal Thickness</u>	<u>Mitotic Index</u>	<u>Number of Cells</u>	<u>Cellular Diameter</u>	<u>Dead Cells</u>
Day 1	-	0.75	-	-	1.25
Day 2	17.1	10.88	208	10.2	0.88
Day 4	14.9	6.13	216	9.4	1.25

ANALYSIS AND INTERPRETATION OF THE RESULTS

A more thorough statistical examination was made of the control results obtained in Chapter 5 to determine the exact values at which the changes in the various parameters became significant. Special attention was paid to the connection between the level of cellular division and the size of the cell population. An analysis was carried out on the measurements made on all the shaved control skins sampled at 11.30 hours and the results are presented in Table 32. The changes in the various parameters were then studied to determine those features which appeared to be related to the activity of the test substances. The significant features obtained by analysis of the response patterns were then coded as follows:

- A. Mitotic index less than 2.36 on Day 1.
- B. Mitotic index on Day 2 less than that on Day 1.
- C. Mitotic index greater than 5.14 on Day 2.
- D. Cell population less than 166 on Day 2.
- E. Cell population less than 185 on Day 2 when the mitotic index is greater than 5.14.
- F. Cell population greater than 204 on Day 4.
- G. Cellular diameter greater than 8.7 on Days 2 or 4.
- H. Degenerate cell incidence greater than 4.0 on Day 2.
- J. A marked decrease in the cell population between twenty-seven hours and seventy-five hours after painting.

In this way the response patterns were subjected to a close qualitative comparison, based upon strict quantitative criteria and the test substances were found to separate into groups of which the respective members all possessed the same activity. (Table 33).

TABLE 32

Analysis of Shaved Control Results

(Series B from Chapter 5)

Distribution of mitotic index of average of four animals
obtained from results of six animals on three separate
occasions at 11.30 hours G. M. T.

S. E.	+3	+2	+1	0	-1	-2	-3
	5.83	5.14	4.44	3.75	3.06	2.36	1.67

Distribution of number of cells per millimetre of epidermis
from average of four animals obtained from results of six
animals on three separate occasions at 11.30 hours G. M. T.

S. E.	+3	+2	+1	0	-1	-2	-3
	215	204	194	184	175	166	158

Distribution of cellular diameter of average of four animals
obtained from results of six animals on three separate
occasions at 11.30 hours G. M. T.

S. E.	+3	+2	+1	0	-1	-2	-3
	9.0	8.7	8.4	8.1	7.8	7.6	7.3

TABLE 33

<u>Test Substance</u>	<u>Response Code</u>										<u>Activity</u>
	A	B	C	D	E	F	G	H	J		
Methylcholanthrene		x		x			x				Potent carcinogen
Dimethyl benzanthracene		x					x				Potent carcinogen
Benzpyrene	x	x		x			x				Potent carcinogen
1.2.5.6. - DBA		x		x			x				Carcinogen
1.2.7.8. - DBA			x		x		x				Weak carcinogen
1.2.3.4. - DBA				x	x		x				Weak carcinogen
Tricycloquinazoline			x	x	x		x				Carcinogen at low dose
Benzanthracene	x										Non-active
Urethane				x							Initiator
Allylthiocyanate	x		x				x	x	x		Irritant
Cantharidin			x				x	x			Irritant
Acridine									x		Irritant
Compound A ₁	x		x			x	x				Promoter
Croton oil	x		x			x	x				Promoter

Some of these results are compared diagrammatically in Figure 38.

Figure 38

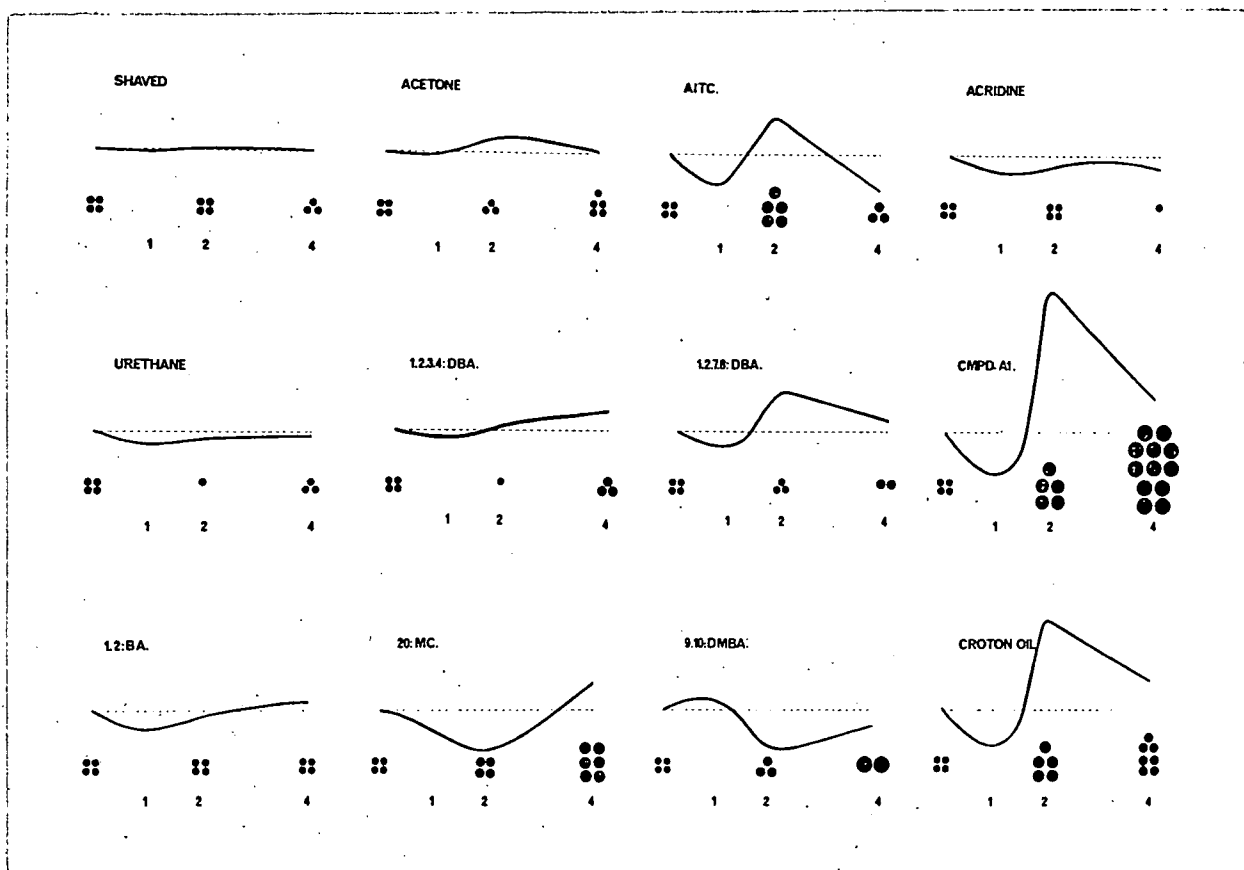

Diagrammatic illustrations of changes in mitotic index, cell population and cell size in the mouse epidermis on the first, second and fourth days following application of various test substances. The curves indicate changes in mitotic index and are superimposed on the dotted line which indicates the normal level of cellular division. The number of cells present in the population is indicated by circles of different sizes representing changes in cell size.

DISCUSSION

These features which have emerged can be recognised as being specifically, characteristically or occasionally associated with the types of activity under investigation. It seems likely that a reduction in the epidermal cell population (D and E), whether it is associated with a reduced mitotic index (A and B) or is brought about by some unknown

mechanism, is a specific response to treatment with an initiating agent. The response to topical application of urethane is apparent between twenty-seven hours and fifty-one hours after application, whereas the response associated with promoting activity proceeds beyond this time and is still apparent at least seventy-five hours after treatment. A relatively persistent hyperplasia (F) would appear to be specifically associated with promoting activity and such a response has been shown to invariably correlate with a high incidence of mitotic division twenty-seven hours after application (C). Other characteristics are an initial suppression of mitosis (A) and a gross hypertrophy of the squamous cells (G). Substances which are in themselves capable of inducing tumours of the epidermis after prolonged treatment, have been shown to evoke responses which show features of both these types. There are indications that the response to a carcinogen depends upon not only the potency, but also the dose level. Application of powerful carcinogens such as methylcholanthrene or dimethylbenzanthracene is followed by a marked depression of mitotic index twenty-seven hours later (B), but this feature changes with decreasing potency to an elevated index associated with a lower cell population than the mitotic index would predict (E). When the dose level of methylcholanthrene is reduced by half, the B response is still of the same order of magnitude, whereas those aspects which are associated with promoting activity i. e. F and G are much reduced. If this trend continues as the dose level is reduced methylcholanthrene

would be expected to behave as an initiating agent with very poor promoting activity at very low doses. Tricycloquinazoline was found to be only slightly soluble in the solvent and was tested at a comparatively low dose level. The results indicated that, under these conditions, its activity would be limited to initiation. Unfortunately, this has not been verified by long term experiments, but these examples are in accord with the two stage theory. Further studies investigating the response to minimal doses of carcinogens are in progress. Treatment with chemical irritants produces a transient hyperplasia and an elevated mitotic index with a high incidence of mitotic cells which is most apparent on the following day.

A similar type of short term test has been developed at the Institut de Recherches sur le Cancer du C. N. R. S. at Villejuif (Lazar Libermann, Chouroulinkor and Fuerin, 1963). This is based on observations of disappearance of the sebaceous glands and development of epidermal hyperplasia in the same strain of mice as have been used in this work. The test substance is applied dropwise in highly volatile solvents such as acetone on three occasions with an interval of forty-eight hours between each. The mice are sampled forty-eight hours after the final application. The number of sebaceous glands, number of nuclei and width of the epidermis are measured in several microscope vision fields. The activity of the test substances is related inversely to the first parameter and directly to the last two parameters. This system has not found wide application because of certain

important limitations:

1. many non-carcinogenic irritants produce identical changes in these parameters;
2. the epidermal thickening produced by tobacco smoke condensate is much greater than that produced by high doses of carcinogenic polycyclic hydrocarbons which give rise to a much greater tumour yield in long term studies;
3. urethane is completely inactive in this test.

On the basis of the results obtained in this work, the above system would probably be very effective in comparing the potency of promoting agents.

The similarity between the response evoked by crude croton oil and its active ingredient (compound A₁) is very striking. The other ingredients might have been expected to have obscured any similarities but the only distinction is in magnitude. The absence of any noteworthy cellular degeneration, coupled with the very high incidence of cellular division, indicates that the changes observed are not associated with a regenerative response. This supports the hypothesis that promoting activity is associated with a stimulative response (Frei and Stephens, 1968).

CONCLUSIONS

1. Potent carcinogens appear to bring about a marked decrease in mitotic activity on the day following application. As would be expected, this is usually accompanied by a

reduction in the epidermal cell population.

2. Promoting agents cause an immediate reduction in mitotic activity followed by a high level of division on the following day which is relatively persistent and causes epidermal hyperplasia.
3. Non-carcinogenic substances may cause marked changes in the epidermal cell population, but the response appears to be non-specific and quite unlike that of carcinogens and co-carcinogens.
4. Weaker carcinogens or potent carcinogens applied in minute quantities cause changes which suggest a combination of the responses brought about by pure initiating and pure promoting agents.

CHAPTER 9

THE APPLICATION OF THE SHORT TERM TEST TO FRACTIONS OF TOBACCO SMOKE CONDENSATE IN AN ATTEMPT TO PREDICT THEIR BIOLOGICAL ACTIVITY IN LONG TERM SKIN PAINTING EXPERIMENTS

INTRODUCTION

RESULTS

Fraction G
Fraction G1
Fraction G2
Fraction G2a
Fraction G2b
Fraction F
Fraction H
Fraction K
Fraction Q
Fraction L(G) 1
Fraction L(G) 2a
Fraction L(G) 2b
Fraction R
Fraction P
Fraction K(G)
Fraction L(G)
Fraction L(G2b)

DISCUSSION

CONCLUSIONS

Repeated and persistent application of tobacco smoke condensate to the shaved back-skin of mice produces benign and malignant tumours in the epidermis and dermis (Wynder, Graham and Croninger, 1953; Day, 1967). The condensate contains many thousands of constituent compounds and identification of those responsible for this activity depends upon a scheme whereby these constituents are separated into

groups of chemically related substances which are then subjected to biological testing. Theoretically the carcinogenic constituents might be expected to separate out in the same group and betray their presence by inducing tumours in a long term skin test at each stage of the fractionation scheme. Those sub-fractions which do not display carcinogenic activity in this way can then be discarded. The process would continue until only carcinogenic substances remain in the final fraction. Once these had been identified, methods could be devised to either prevent their formation or remove them from cigarette smoke. Unfortunately the process does not work out so simply in practice. The two stage cancer mechanism does not require the total carcinogenicity to be located in one substance, (see Chapter 7).

Initiators and cocarcinogens are very often from completely unrelated chemical groups and it has been shown that there are cocarcinogens present in tobacco smoke condensate which separate into fractions other than those containing initiators (Roe, Salaman, and Cohen, 1959; Wynder and Hoffmann, 1961). Evidence for the presence of cocarcinogenic agents was demonstrated as early as 1956 by Gwynn and Salaman and Hamer and Woodhouse. A further problem is the time required to obtain positive results in the long term tests on mouse skin. If the fractionation scheme can only proceed one stage further every two or three years, it could be decades before it is possible to even make an informed guess as to the identity of the active substances. The presence of polycyclic aromatic hydrocarbons and heterocyclic

compounds in smoke condensate has been demonstrated and the sub-fraction in which they were mainly localised was shown to have the highest activity in the Triton test (Bonnet and Neukomm, 1957, Neukomm, 1957). Since these are only present in very small amounts, Wynder and Hoffmann (1968) considered it more likely that some of them were only responsible for initiating the tumour process. The first steps in the fractionation schemes involved the separation of the smoke condensate into basic, phenolic, acidic and neutral fractions and the techniques involved the use of strong acid and alkali (Wynder and Wright, 1957). The activity was mainly localised in the neutral fraction from which Wynder and Hoffmann (1959) isolated a polycyclic aromatic hydrocarbon-rich fraction which also proved to be active in long term tests. Unfortunately there was a considerable discrepancy between the tumour yield obtained after whole smoke condensate treatment and that obtained after treatment with the neutral fraction or recombinations of the four sub-fractions mentioned above. It seemed likely that some of the substances responsible for the carcinogenic activity of the condensate were being inactivated by the separation procedure. As a result, an alternative fractionation scheme (Figure 39) was developed at these laboratories using solvent partition methods (Whitehead and Rothwell, 1969). This scheme was also aimed at concentrating the polycyclic aromatic hydrocarbons into a single fraction, but there is reason to be less confident about the importance of these compounds.

Figure 39

SMOKE CONDENSATE FRACTIONATION SCHEMES

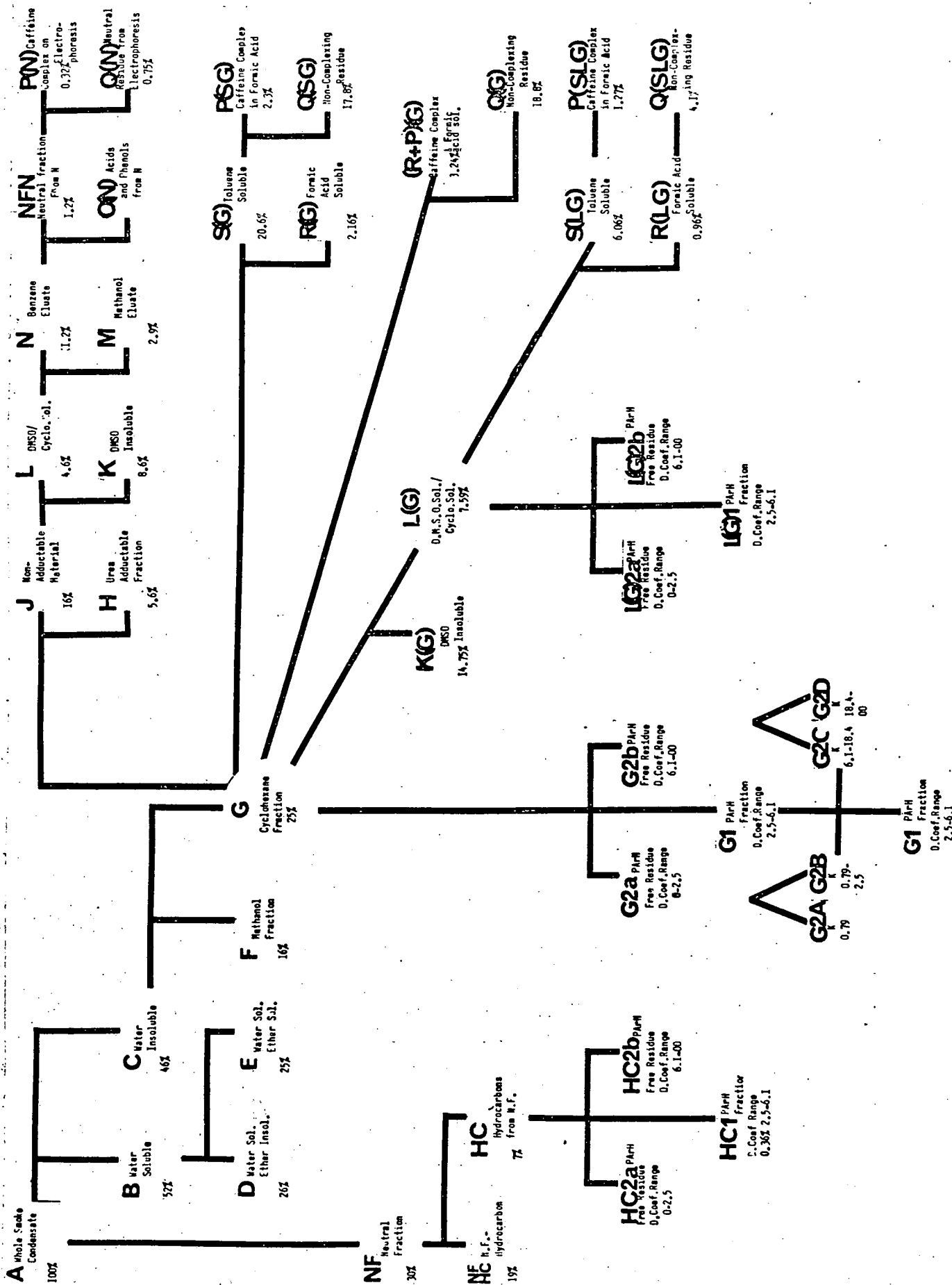

Fractions and sub-fractions of tobacco smoke condensate were selected by the Senior Chemist, recoded and examined by the preliminary screening method developed in Chapter 8 in a "blind" test.

RESULTS

Numerical values and coded response patterns are compared with the results obtained from shaved control animals in Table 34. The figures given for percentage of tumour bearing animals are obtained from those long term experiments which have been completed at the time of writing. These experiments are directed by the pathologist, Dr. R. F. Davies, who confirms the presence of tumours histologically. The fractions are applied to the shaved backs of mice three times a week from the age of about ten weeks to the time when they are considered to have a tumour which has penetrated the panniculus carnosus or until they die. Further information on the techniques employed in the long term experiments may be found in the reports which have been published (Day, 1967; Davies and Day, 1969; Whitehead and Rothwell, 1969).

Seventeen fractions and sub-fractions were tested and two of these were duplicated, although this was not known at the time. In each case the dose was equivalent to 200 mg. of whole smoke condensate (A).

Fraction G - (Coded ST86)

The mild initiating response (E) coupled with a comparatively potent promoting pattern (ACG) indicated that the test substance would

TABLE 34

Changes in the Epidermis at 11.30 Hours G. M. T. on the First, Second and Fourth Days following Single Applications of Fractions of Tobacco Smoke Condensate at 08.30 Hours on Day 1

Fraction	Hours after Painting						Response Patterns (Refer to Text)	Percentage of T. B. A. from Long Term Experiments
	3			27				
	M	N	S	M	N	S		
Shaved controls	3.65	3.84	189	8.4	0.50	179	7.8	2
P	1.50	4.25	172	9.5	1.63	177	9.3	2
L(G)2b	1.63	3.25	165	8.7	1.75	170	8.4	AG
L(G)2b	1.13	4.38	161	8.6	0.88	166	8.7	AD
G2b	1.75	6.38	166	8.9	0.75	188	9.2	AD
G2b	0.50	5.63	176	9.4	3.13	154	8.9	ACDEG
L(G)1	1.13	5.88	149	8.6	1.38	168	8.3	ACEGJ
K(G)	0.38	7.00	177	9.6	1.50	181	9.4	ACDE
G1	0.63	7.38	181	9.4	1.50	170	8.4	ACEG
R	1.13	9.38	182	10.2	1.50	171	9.4	ACEG
G	0.25	10.50	177	10.9	0.63	178	9.6	ACEG
G2	1.00	19.13	178	11.0	1.88	171	9.5	ACEG
Q	0.88	10.25	182	9.8	1.63	167	9.0	ACEG
L(G2b)	2.00	7.13	194	9.5	1.38	152	8.9	ACEG
G2a	1.50	10.38	202	10.8	1.38	178	9.3	ACGJ
F	0.13	18.25	185	10.2	0.88	201	10.2	ACGJ
H	1.63	11.38	186	9.4	1.25	187	9.0	ACG
L(G)	1.25	12.25	191	10.3	1.63	179	9.0	ACG
L(G)2a	1.50	13.50	194	10.5	1.25	178	9.2	ACG

M - Mitotic Index N - Number of Cells S - Cellular Diameter D - Dead Cells

be capable of inducing epidermal tumours when applied persistently at a high dose level.

Fraction G1 - (Coded ST87)

The initiating response (E) was borderline and the promoting response (ACG) was much lower than that obtained with G suggesting that, although the test substance was a total carcinogen, its activity would be very limited.

Fraction G2 - (Coded ST88)

In this case the initiating response was less marked than with G, but the promoting response was greater, suggesting that this substance would be capable of tumour production, but the yield would be increased by priming the skin with small initiating doses of methylcholanthrene or dimethyl-benzanthracene.

Fraction G2a - (Coded ST89)

This gave a moderately strong promoting response, but there was evidence of the presence of irritant substances and this leads to confusion in trying to estimate the magnitude of the promoting response. No initiating activity was detected.

Fraction G2b - (Coded ST90 and ST108)

This gave a well defined initiating response and a slight promoting response. This material would be expected to produce a few skin tumours in a long term experiment.

Fraction F - (Coded ST95)

A powerful promoting response was demonstrated and very slight.

initiating activity. This material may produce skin tumours in a long term experiment, but only a small number, unless the skin had been primed with a powerful initiator when it would probably produce a high proportion.

Fraction H - (Coded ST96)

The result was similar to Fraction F, but the promoting response was only about half as marked.

Fraction K - (Coded ST97)

After counting only a few skins, it became evident that the results were equivocal and counting was stopped. This material is either non-active or was dissolved in an unsuitable solvent vehicle.

Fraction Q - (Coded ST98)

The response suggests that this substance is a carcinogen with sufficient initiating and promoting activity to produce a fairly high tumour yield in a long term experiment.

Fraction L(G) 1 - (Coded ST99)

This substance produced a strong initiating response, but the promoting response was very limited and suggests that only a low tumour yield would be obtained in a classical long term experiment. Painting this material in conjunction with a promoting agent such as croton oil would probably produce quite a high yield of tumours.

Fraction L(G) 2a - (Coded ST100)

This produced a similar response to that obtained after croton oil treatment. There were some differences in magnitude; the

mitotic index was slightly higher twenty-seven hours after painting and the cell population was slightly lower and this could be interpreted as indicating traces of initiating material. It is possible that a long term experiment could produce several tumours, but this is more likely if the skin is primed with a small dose of dimethylbenzanthracene.

Fraction L(G) 2b - (Coded ST101 and ST107)

The response was very similar to that given by urethane and indicated that this substance is entirely initiating. Although urethane is incapable of inducing tumours from the epidermis, it is a total lung carcinogen and this may also be true for this fraction.

Fraction R - (Coded ST103)

The response suggests that this is a much milder carcinogen than Fraction Q. A low tumour yield would be expected in a long term experiment.

Fraction P - (Coded ST104)

There were fluctuations in the various parameters, but the mean values were inside the shaved control confidence limits. At this dose level it would appear to be inactive.

Fraction K(G) - (Coded ST105)

This produced a weak carcinogen response, similar to that of Fraction G1.

Fraction L(G) - (Coded ST106)

This demonstrated a promoting response, but the initiating response was entirely absent. Such a result is somewhat anomalous

since subfractions have demonstrated initiating activity. It may be that a fairly powerful promoting response could overwhelm and obscure a relatively mild initiating response.

Fraction L (G2b) - (Coded ST109)

This demonstrated a mild promoting response.

DISCUSSION

Long term experiments have shown that almost all the activity of tobacco smoke condensate is found in Fraction C which contains all the polycyclic aromatic hydrocarbons. These are then concentrated into Fractions G, J, L and N respectively. Carcinogenic activity is confirmed by tumour induction after repeated skin painting, but the activity of Fraction N is much lower than that of the others and only about one fifth of Fraction G. It would seem that much of the activity had become bound to the silica gel and could not be regained, since recombination of N and M still only produced about one fifth of the activity of G. An alternative system was adopted in which G was separated by a counter current distribution between cyclohexane and aqueous methanol into three sub-fractions of which the middle one, G1, was shown to contain the polycyclic hydrocarbons. The other two were combined to give G2. In long term experiments, G2 was unexpectedly found to be more active than G1. The short term response patterns suggest that the main promoting activity has separated into G2a, whilst the main initiating activity has separated into G2b and the residual promoting and initiating activity is found in G1.

Fraction L(G) was obtained from G by omitting the intermediate (Fraction J) stage. When this was submitted to a similar counter current distribution the short term response indicated that the initiating activity previously associated with G2b had now appeared in L(G)1. The explanation for this phenomenon might be associated with the physical properties of the active substances.

Waxy substances are more soluble in cyclohexane and would, therefore, appear in G2b, unless there is pretreatment with dimethylsulphoxide, when the waxy substances would pass into K(G) leaving the active principle in L(G). In the absence of these waxy substances, the latter would then be less soluble in cyclohexane and pass into L(G)1. These observations have not been confirmed by long term experiments since, at the time of writing, these are in the early stages and no tumours have yet appeared.

There is a striking similarity between the response to Fraction F and that produced by compound A₁. Whether this will prove to be such a potent promoting agent remains to be demonstrated and long term experiments are due to start shortly.

CONCLUSIONS

1. None of the fractions produced the response pattern typical of potent carcinogens.
2. Several fractions, in particular Fraction F, produced a response pattern which has been shown to be typical of cocarcinogenic promoting agents.

3. In some cases a mild initiating response pattern could be discerned, coupled with some aspects of the promoting response.
4. The initiating activity of tobacco smoke condensate is very low and may be almost negligible.
5. Tobacco smoke condensate has a considerable promoting activity which may be due to several different chemical constituents because it was distributed between many of the fractions.
6. It may be more meaningful to consider that tobacco smoke contains a tumour promoter than to regard it as a primary cancer causing agent.

CHAPTER 10

GENERAL DISCUSSION

PRACTICAL CONSIDERATIONS

IRRITATION VERSUS PROMOTION

TOBACCO SMOKE CONDENSATE - ITS MODE OF ACTION

VALUE OF THE SCREENING TEST

THEORETICAL CONSIDERATIONS

PRACTICAL CONSIDERATIONS

The crux of this technique lies in recognition of the rapidity with which the mitotic index changes throughout the day, and the importance of carrying out the various procedures at exactly the same time each day. Delays of even an hour or two would produce spurious results and a valid interpretation would be impossible. Moreover, the action of such a mild solvent as acetone, which does not seem to have any visible effect upon the epidermis in thin sections, indicates that the choice of test vehicle is not to be taken lightly. Organic solvents, such as benzene and toluene, produce changes which are likely to obscure the delicate fluctuations in the epidermal cell population. Using this technique, much valuable information can be obtained in a short space of time after only a single application of the test substance.

IRRITATION VERSUS PROMOTION

The response patterns observed after treatment with allyl-isothiocyanate, acridine and cantharidin suggest that irritant treatment is not associated with any characteristic changes in the epidermal cell population. Disturbances undoubtedly occur in the rhythm of proliferation and this is generally, but not invariably associated with changes in cell size. The activity can probably be distinguished into two types; toxic irritation which results in cellular degeneration leading to pyknosis and karyolysis at the cellular level and acanthosis and hyperkeratosis at the tissue level, and non-toxic irritation which affects the proliferative compartment, but causes no visible alteration in epidermal structure at either level. On the other hand, promoting agents would seem to produce a characteristic response. Croton oil, compound A₁ and fractions F, H, G2a and L(G) 2a all produce similar changes and the progress of these changes would seem to be identical. Acanthosis in this case is extensive, massive and very persistent, but the most striking aspect is the absence of the gross degenerative changes seen after toxic irritation. Hyperkeratosis and gross hypertrophy form part of the response, but again this is not focal as it appears to be after toxic irritant treatment. These differences in the response patterns all point to a secondary regenerative response to injury following irritant treatment and a primary stimulative action on the part of the promoting agents.

TOBACCO SMOKE CONDENSATE - ITS MODE OF ACTION

None of the fractions produced a depression in the mitotic index on the day following treatment. This change was observed after treatment with all the potent polycyclic hydrocarbons and would appear to be associated with their initiating properties. It seem likely, therefore, that tobacco smoke condensate either only contains traces of initiating material or the activity of the initiating agents is very weak. On the other hand, the similarity between the responses of compound A₁ and fraction F suggests that the promoting activity may be very marked. These observations only apply to the activity of the condensate on the skin of mice and may be of little relevance to its activity in lung tissue. Urethane produces lung tumours in mice, but the epidermal response bears no resemblance to that of compound A₁ and little resemblance to that of the carcinogenic polycyclic hydrocarbons. It would be useful to turn to an examination of the changes in the epithelium of trachea and bronchi under the influence of these substances. Unfortunately these epithelia are not so easy to work with since it is difficult to apply the test substances with any degree of certainty. Small rodents almost invariable breathe through the nose and the mucous membranes covering the scroll bones remove many of the ingredients of smoke and aerosols. Many of the disadvantages can be overcome by performing the experiments on isolated pieces of tissue in organ culture and such a programme is scheduled to start in the near future. It is hoped that the execution of this programme will be greatly facilitated by the observations made on the epidermal cell population.

VALUE OF THE SCREENING TEST

Quantitative correlations could not be recognised, but the qualitative nature of the procedure does not reduce its value as a preliminary screening test. Not only is it a rapid bio-assay technique but it has the advantage of demonstrating initiating and promoting activity separately. In a long term experiment using topical application, the only criterion which can be used is the induction of tumours. Pure initiating agents or pure co-carcinogenic substances are not recognisable in a simple long term test, since they are incapable of producing tumours even though they may be very potent. In order to demonstrate their activity, it is necessary to set up a more complicated system in which they are applied in conjunction with the complementary agent, and, in many cases, there is insufficient evidence to go to such lengths. On the other hand, the production of tumours is the only satisfactory criterion which can be used in identifying a potentially active substance and this short term technique can never be more than a screening test to be used in conjunction with the classical long term system.

THEORETICAL CONSIDERATIONS

High resolution autoradiography with tritiated thymidine has produced information on the progress and fate of cells in a dividing population (review; Baserga, 1965). In the epidermis either or both of the daughter cells produced by mitotic division may differentiate into keratin plates, or they may remain attached to the basement membrane

and subsequently divide again. Nothing is known about the influence which determines which of these courses the cell will follow. The progress of the basal cells between one mitosis and the next is known as the cell cycle (Howard and Pelc, 1951) and is believed to last for about one hundred and fifty hours in the mouse epidermis (Dormer, Tulinius and Oehlert, 1964). Before division can take place, the cells must double the nuclear DNA content so that duplication of the chromosomes can occur. A distinct period of DNA synthesis has been recognised which last for about eight hours and is known as the S phase of the cell cycle. The period prior to the S phase and following the last division has been distinguished into two phases G₀ and G₁. G₀ is believed to be variable in duration and in a period of intense cell production may be non-existent. G₁ is the first phase in a proliferative sequence of events which are believed to be constant in duration. During this phase the cell synthesises RNA and proteins for about fifteen hours. S is followed by a second phase of RNA synthesis known as G₂ which lasts for about one hour and is followed by the first stage of mitosis. Therefore, the series of events (G₁, S, G₂ and M) through which the cell must continue to proceed, once it has been committed, lasts for a total of just over twenty-four hours. This would suggest that the depression in mitotic index which has been observed twenty-seven hours after single applications of potent polycyclic hydrocarbons, results from changes brought about in the latent basal cells in the G₀ phase. Allison and Paton (1969) have

suggested that carcinogens attack the lysosomes of latent basal cells, allowing enzymes to escape which subsequently alter the nuclear membrane. This could then be followed by an attack on the nuclear constituents, either by the enzymes of other tissue or cell components, or by the carcinogens. The evidence accumulated in this investigation of short term response patterns suggests that initiating activity is exerted within forty-eight hours of application and this is supported by the observation that single small doses of initiator are sufficient to start the tumour process in long term experiments. If the transformation occurs in latent basal cells during the first forty-eight hours of exposure to air, do these transformed cells remain in G0 or are they the small number seen to be dividing twenty-seven hours later? Since depression of the mitotic index does not occur after urethane treatment, it is possible that the initiating transformation does not produce a cellular breakdown great enough to prevent the cells from entering the proliferative compartment. When this occurs with methylcholanthrene, it may be because the damage is unnecessarily severe. On this assumption, it would seem likely that the small number of cells, seen to be dividing twenty-seven hours after the treatment, include the transformed cells. If the latter were able to proceed to the next division in a normal manner, the chances of their being lost by differentiation and exfoliation would be increased. It is more likely that they remain attached to the basement membrane in a comparatively quiescent state. This is supported by the observations that delay in subsequent croton oil treatment produces an equivalent prolongation of the latent period without a reduction in tumour yield. Carrying the

discussion to its logical conclusion, the stimulative action of a promoting agent forces the quiescant transformed cells to pass through the proliferating compartment. Repeated treatment increases the cells ability to do this and eventually it reacquires the ability to cycle on its own, leading to multiplication and eventually a tumour.

REFERENCES

ALLISON, A. C. and PATON, G. R. - (1969)

Lysosomes, chromosomes and cancer.

Biochem. J., 115, 31.

ANDREASEN, E. - (1953)

Cyclic changes in the skin of the mouse.

Acta. Path. Scand., 32, 157.

BADGER, G. M., COOK, J. W., HEWETT, C. L., KENNAWAY, E. L.,

KENNAWAY, N. M., MARTIN, R. H. and ROBINSON, A. M. - (1940)

The production of cancer by pure hydrocarbons. Part V.

Proc. Roy. Soc., B 129, 439

BALDWIN, R. W., CUNNINGHAM, G. J. and PARTRIDGE, M. W. -

(1959)

Studies of the carcinogenic action of tricycloquinazoline.

Brit. J. Cancer, 13, 94

BARRY, G., COOK, J. W., HASLEWOOD, G. A. D., HEWETT, C. L.,

HIEGER, I. and KENNAWAY, E. L. - (1935)

The production of cancer by pure hydrocarbons. Part III.

Proc. Roy. Soc. B 117, 318

BASERGA, R. - (1965)

The relationship of the cell cycle to tumour growth and control of
cell division: A review.

Cancer Res., 25, 581

BERENBLUM, I. - (1929)

The modifying influence of dichlorethylsulphide on the induction of tumours in mice by tar.

J. Path. Bact., 32, 425.

BERENBLUM, I. - (1935)

Experimental inhibition of tumour induction by mustard gas and other compounds.

J. Path. Bact., 40, 549.

BERENBLUM, I. - (1941)

The cocarcinogenic action of croton resin.

Cancer Res., 1, 44.

BERENBLUM, I. - (1941)

The mechanism of carcinogenesis. A study of the significance of cocarcinogenic action and related phenomena.

Cancer Res., 1, 807.

BERENBLUM, I. and SHUBIK, P. - (1947)

A new, quantitative approach to the study of the stages of chemical carcinogenesis in the mouse's skin.

Brit. J. Cancer, 1, 383.

BERENBLUM, I. and SHUBIK, P. - (1949)

The persistence of latent tumour cells induced in the mouse's skin by a single application of 9.10 - dimethyl 1.2 - benzanthracene.

Brit. J. Cancer, 3, 109.

BERG, N. O. - (1948)

Comparison of the epidermal hyperplasia in the skin of mice
after application of carcinogenic and non-carcinogenic irritants.

Acta. Path. Microbiol. Scand., 25, 34.

BERTALANFFY, F. D. - (1964)

Tritiated thymidine versus colchicine technique in the study of
cell population cytodynamics.

Lab. Invest., 13, 871.

BEST, E. W. R., JOSIE, G. H. and WALKER, C. B. - (1960)

A Canadian study of mortality in relation to smoking habits. A
preliminary report.

Canad. J. Publ. Hlth., 52, 99.

BONNET, J. and NEUKOMM, S. - (1957)

On the chemical composition of tobacco smoke. II The alkaline
fraction.

Helv. Chim. Acta, 40, 113.

BULLOUGH, W. S. - (1946)

Mitotic activity in the adult female mouse, *Mus musculus* L. A
study of its relation to the oestrous cycle in normal and
abnormal conditions.

Phil. Trans., B 231, 453.

BULLOUGH, W. S. - (1949)

Age and mitotic activity in the male mouse, *Mus musculus* L.

J. Expt. Biol., 26, 261.

BURROWS, H., ROE, E. M. F. and SCHOBBER, P. - (1945)

Potential differences in the skin of mice during carcinogenesis.

Cancer Res., 5, 524.

CHASE, H. B., MONTAGNA, W. and MALONE, J. D. - (1953)

Changes in the skin in relation to the hair growth cycle.

Anat. Rec., 116, 75.

COOK, J. W. - (1932)

The production of cancer by pure hydrocarbons. Part II.

Proc. Roy. Soc., B 111, 485

COOK, J. W., HIEGER, I., KENNAWAY, E. L. and MAYNEORD, W. V. -

(1932)

The production of cancer by pure hydrocarbons. Part I.

Proc. Roy. Soc., B 111, 455

COOPER, Z. K. and FRANKLIN, H. C. - (1940)

Mitotic rhythm in the epidermis of the mouse.

Anat. Rec., 78, 1.

CRAMER, W. and STOWELL, R. E. - (1942)

The early stages of carcinogenesis by 20 - methylcholanthrene in
the skin of the mouse. I Experimental technique and macroscopic
changes.

J. Nat. Cancer Inst., 2, 379.

CRAMER, W. and STOWELL, R. E. - (1943)

Skin carcinogenesis by a single application of 20 - methylcholanthrene.

Cancer Res., 3, 36.

CRAMER, W. and STOWELL, R. E. - (1943)

On the qualitative evaluation of experimental skin carcinogenesis by methylcholanthrene. The factors of dosage, time, spacing of application and the multiplicity of the carcinogenic response.

Cancer Res., 3, 668.

DAY, T. D. - (1967)

Carcinogenic action of cigarette smoke condensate on mouse skin - an attempt at a quantitative study.

Brit. J. Cancer, 21, 56.

DAVIES, R. F. and DAY, T. D. - (1969)

A study of the comparative carcinogenicity of cigarette and cigar smoke condensate on mouse skin.

Brit. J. Cancer, 23, 363.

DOLL, W. R. and HILL, A. B. - (1954)

The mortality of doctors in relation to their smoking habits. A preliminary report.

Brit. Med. J., i, 1451.

DOLL, W. R. and HILL, A. B. - (1956)

Lung cancer and other causes of death in relation to smoking ; a second report on the mortality of British doctors.

Brit. Med. J., ii, 1071

DORMER, P., TULINIUS, H. and OEHLERT, W. - (1964)

Untersuchungen über die generationszeit, DNS - synthesezeit
und mitosedauer von zeller der hyperplastischen epidermis
und des plattenepithelcarcinoms der maus nach
methylcholanthrenpinselung.

Z. Krebsforsch., 66, 11.

DUSTIN, P. - (1959)

The quantitative estimation of mitotic growth in the bone marrow
of the rat by the stathmokinetic (colchicine) method.

In Stohlman, F., The Kinetics of Cellular Proliferation.

Grune and Stratton, Inc., London.

EIGSTI, O. J. and DUSTIN, P. - (1955)

Colchicine in Agriculture, Medicine, Biology and Chemistry.

The Iowa College Press, Ames.

ELGJO, K. - (1963)

Duration and rate of mitosis after a single application of
methylcholanthrene.

Nature, 200, 608.

ELGJO, K. - (1966)

Epidermal cell population kinetics in chemically induced hyperplasia.

Norwegian monographs on medical science.

EVENSEN, A. - (1961)

Changes in the synthesis of desoxyribonucleic acid (DNA) and
in mitotic count in epidermis of hairless mice after a single
application of one per cent 3 - methylcholanthrene in benzene.
Acta path. microbiol. Scand., 148, 43.

EVENSEN, A. - (1962)

Significance of mitotic duration in evaluating kinetics of cellular
proliferation.

Nature, 195, 718.

EVENSEN, A. - (1964)

Epidermal mitoses. Effect of adrenaline.

Proc. XIV Scand. Congr. Path. Microbiol., Universitetsforlaget.,
Oslo, 175-176.

EVENSEN, A. and IVERSEN, O. H. - (1962)

Rate of cell proliferation in a mouse squamous cell carcinoma.

Nature, 196, 383.

FLEMMING, W. - (1884)

Zur kenntwiss der regeneration der epidermis beim saugetier.

Arch mikroskop. Anat. u. Entuicklungsmech, 23, 148.

FREI, J. V. and STEPHENS, P. - (1968)

The correlation of promotion of tumour growth and of induction
of hyperplasia in epidermal two-stage carcinogenesis.

Brit. J. Cancer, 22, 83.

GLUCKSMANN, A. - (1945)

The histogenesis of benzpyrene induced epidermal tumours in the mouse.

Cancer Res., 5, 385.

GRAFFI, A., VLAMYNCK, E., HOFFMANN, F. and SCHULZ, J. - (1953)

Untersuchungen uber die geschwulstauslosende wirkung verschiedener chemischen stoffe in der kombination mit crotonol

Arch Geschwulst., 5, 110.

GREULICH, R. C. - (1964)

Aspect of cell individuality in the renewal of stratified squamous epithelia.

In Montagna, W. and Lobitz, W. C. The Epidermis.

Academic Press, New York.

GWYNN, R. H. and SALAMAN, M. H. - (1953)

Studies on cocarcinogenesis. SH - reactors and other substances tested for cocarcinogenic action in mouse skin.

Brit. J. Cancer, 7, 482.

GWYNN, R. H. and SALAMAN, M. H. - (1956)

Tests for tobacco products for tumour initiation and promotion in mouse skin.

British Empire Cancer Campaign 34th Annual Report, p 193.

HAMER, D. and WOODHOUSE, D. L. - (1956)

Biological tests for carcinogenic action of tar from cigarette
smoke.

Brit. J. Cancer, 10, 49.

HARRIS, R. J. C. and NEGRONI, G. - (1967)

Production of lung carcinomas in C57BL mice exposed to a
cigarette smoke and air mixture.

Brit. Med. J., 4, 637.

HECKER, E. and PAUL, D. - (1968)

Zum biochemischen mechanismus der carcinogenese der
mausehaut. 1. Verteilung und stoffwechsel intragastral
verfütterten 9.10 - dimethyl 1.2 - benzantracene in der
maus.

Z. Krebsforsch., 71, 153

HECKER, E. and SCHAIRER, H. U. - (1967)

Über die Wirkstoffe des crotonols VIII Verbessertes
isolierungserfahren für die wirkstoffgruppen A und B
sowie isolierung und charakterisierung weiterer wirkstoffe
der Gruppe A.

Z. Krebsforsch., 70, 1.

HILL, W. T., STANGER, D. W., PIZZO, A., RIEGEL, B.,

SHUBIK, P. and WARTMAN, W. B. - (1951)

Inhibition of 9.10 - dimethyl 1.2 - benzantracene skin
carcinogenesis in mice by polycyclic hydrocarbons.

Cancer Res., 11, 892.

HOFFMANN, D. and WYNDER, E. L. - (1966)

The tumour initiator in tobacco smoke (Abstract 123).

Proc. Am. Ass. Cancer Res., 7, 32.

HOWARD, A. and PELC, S. R. - (1951)

Nuclear incorporation of P-32 as demonstrated by autoradiographs.

Exptl. Cell Res., 2, 178.

IVERSEN, O. H. - (1960)

Cell metabolism in experimental skin carcinogenesis.

Act path. microbiol. Scand. 50, 17.

IVERSEN, O. H. - (1960)

A homeostatic mechanism regulating the cell number in epidermis.

Proc. 1st Congr. int. cybernetic. Med., Gianni, Napoli.

IVERSEN, O. H. - (1961)

The regulation of cell numbers in epidermis. A cybernetic point
of view.

Acta path. microbiol. Scand. Suppl., 148, 91.

IVERSEN, O. H., AANDAHL, E. and ELGJO, K. - (1965)

The effect of an epidermis - specific mitotic inhibitor (chalone)
extracted from epidermal cells.

Acta path. microbiol. Scand., 64, 506.

IVERSEN, O. H. and BJERKNES, R. - (1963)

Kinetics of epidermal reaction to carcinogens.

Acta path. microbiol. Scand., Suppl. 165.

IVERSEN, O. H. and EVENSEN, A. - (1962)

Experimental skin carcinogenesis in mice.

-Acta path. microbiol. Scand., Suppl. 156.

IVERSEN, O. H. and IVERSEN, U. - (1964)

A study of epidermal tumourigenesis in the hairless mouse
with a single and with repeated applications of 3 - methyl-
cholanthrene at different dosages.

Acta path. microbiol. Scand., 62, 305.

IVERSEN, S. and EDELSTEIN, J. M. - (1952)

On the mechanism of experimental carcinogenesis. 4 The early
mitotic effect of 9.10 - dimethyl 1.2 - benzantracene and
1.2.5.6 - dibenzanthracene on epidermal cells of the mouse
ear.

Acta path. microbiol. Scand., 30, 213.

KENNAWAY, E. L. - (1924)

The formation of cancer producing substances from isoprene
(2 - methylbutadiene).

J. Path. Bact., 27, 233.

KENNAWAY, E. L. - (1924)

On the cancer producing factor in tar.

Brit. Med. J., 1, 564.

KENNAWAY, E. L. - (1924)

On cancer producing tars and tar fractions.

J. Indust. Hyg., 5, 462.

KENNAWAY, E. L. - (1930)

Further experiments on cancer producing substances.

Biochem. J., 24, 497.

LACASSAGNE, A., BUU-HOI, N. P., LECOCQ, J. and RUDALI, G. -
(1946)

Activite cancerigene, sur la peau de la souris, de substances du
groupe des benzacridines angulaires.

Bull. Assoc. franc. p. l'etude du cancer, 33, 48.

LAZAR, P. LIBERMANN, C., CHOUROULINKOV, I. and
GUERIN, M. - (1963)

Tests sur la peau de souris pour la determination des activites
carcinogenes: Mise au point methodologique.

Bulletin du Cancer, 50, 567.

LIANG, Hsu-Mu. - (1947)

Localised changes in methylcholanthrene treated epidermis.

Cancer Res., 7, 211.

MACKENZIE, I. and ROUS, P. - (1941)

The experimental disclosure of latent neoplastic changes in
tarred skin.

J. exp. Med., 73, 391.

MAJOR, I. R. - (1970)

Correlation of initial changes in the mouse epidermal cell
population with two stage carcinogenesis - A quantitative study.

Brit. J. Cancer, 24, 149.

MONTAGNA, W. - (1962)

Structure and function of skin, (2nd Edition).

Academic Press.

MOTTRAM, J. C. - (1944)

A sensitising factor in experimental blastogenesis.

J. Path. Bact., 56, 391.

MOTTRAM, J. C. - (1944)

A developing factor in experimental blastogenesis.

J. Path. Bact., 56, 181.

NETTLESHIP, A. and HENSHAW, P. S. - (1943)

Induction of pulmonary tumours in mice with ethyl carbamate
(urethane).

J. Nat. Cancer Inst., 4, 309.

NEUKOMM, S. - (1957)

Recherches experimentales sur le pouvoir cancerigene de la
fumee du tabac et d'autres polluants de l'atmosphere.

Oncologia, Basel, 10, 137.

OEHLERT, W. and GRIMM, D. - (1966)

Das verteilungs und einbaumuster radioaktiv markeirter
carcinogene in der mausenepidermis nach lokaler applikation.

Z. Krebsforsch., 68, 14.

ORR, J. W. - (1938)

The changes antecedent to tumour formation during the treatment
of mouse skin with carcinogenic hydrocarbons.

J. Path. Bact., 46, 495.

PAGE, R. C. - (1938)

Cytologic changes in the skin of mice during application of
-carcinogenic agents.

Arch. Path., 26, 800.

PAUL, D. - (1969)

Effects of carcinogenic, non-carcinogenic and cocarcinogenic
agents on the biosynthesis of nucleic acids in mouse skin.

Cancer Res., 29, 1218.

PEACOCK, P. M. and PEACOCK, P. R. - (1966)

Spontaneous and induced hyperplasia and neoplasia in the mouse
lung.

Brit. J. Cancer, 20, 127.

PULLINGER, B. D. - (1940)

The first effects on mouse skin of some polycyclic hydrocarbons.

J. Path. Bact., 50, 463.

PULLINGER, B. D. - (1941)

Correlation between carcinogenic potency and the first skin
reaction to certain hydrocarbons.

J. Path. Bact., 53, 287.

PULLINGER, B. D. - (1945)

A measure of the stimulating effect of simple injury combined
with carcinogenic chemicals on tumour formation in mice.

J. Path. Bact., 57, 477.

RELLER, H. C. and COOPER, Z. K. - (1944)

Mitotic incidence in the first forty-eight hours of methylcholanthrene
epidermal carcinogenesis.

Cancer Res., 4, 236

RILEY, J. F. - (1966)

Mast cells and cancer in the skin of mice.

Lancet, 2, 1457.

ROE, F. J. C. and SALAMAN, M. H. - (1955)

Further studies on incomplete carcinogenesis; Triethylene

melamine (T. E. M.), 1.2: - benzanthracene and β -

propiolactone as initiators of skin tumour formation in the

mouse.

Brit. J. Cancer, 9, 177.

ROE, F. J. C., SALAMAN, M. H. and COHEN, J. - (1959)

Incomplete carcinogens in cigarette smoke condensate: tumour-

promotion by a phenolic fraction.

Brit. J. Cancer, 13, 623.

ROUS, P. and KIDD, J. G. - (1941)

Conditional neoplasms and subthreshold neoplastic states. A

study of the tar tumours of rabbits.

J. exp. med., 73, 365.

SALAMAN, M. H. and ROE, F. J. C. - (1953)

Incomplete carcinogens : ethyl carbamate (urethane) as an

initiator of skin tumour formation in the mouse.

Brit. J. Cancer, 7, 472.

SETALA, K. - (1956)

Tumour promoting and cocarcinogenic effects of some non-ionic

lipophilic - hydrophilic (surface active) agents. An experimental

study on skin tumours in mice.

Acta path. microbiol. Scand., Suppl. 115.

SETALA, K., SETALA, H., MERENMIES, L. and HOLSTI, P. -
(1957)

Untersuchungen über die tumorauslösende (tumour promoting)
Wirkung einiger nichtionisierbaren oberflächenaktiven
Substanzen bei Maus und Kaninchen.

Z. Krebsforsch., 61, 534.

SETALA, K., MERENMIES, L., STJERNVALL, L., NYHOLM, M.
and AHO, Y. - (1960)

Mechanism of experimental tumorigenesis. V Ultrastructural
alterations in mouse epidermis caused by Span 60 and Tween 60
type agents.

J. Nat. Cancer Inst., 24, 355.

SIMPSON, W. L. and CRAMER, W. - (1943)

Fluorescence studies of carcinogens in skin. I Histological
localization of 20 - methylcholanthrene in mouse skin after a
single application.

Cancer Res., 3, 362.

SIMPSON, W. L. and CRAMER, W. - (1945)

Fluorescence studies of carcinogens in skin. II Mouse skin
after single and multiple applications of 20 - methylcholanthrene.

Cancer Res., 5, 449.

STEVENS HOOPER, C. E. - (1961)

Use of colchicine for the measurement of mitotic rate in the
intestinal epithelium.

Am. J. Anat., 108, 231.

STEWART, H. L. and HERROLD, K. M. - (1962)

A critique of experiments on attempts to induce cancer with
tobacco derivatives.

Bull. intern. statist. Inst., 39, 457.

SUNTZEFF, V. and CARRUTHERS, C. - (1946)

The water content in the epidermis of mice undergoing carcinogenesis
by methylcholanthrene.

Cancer Res., 6, 574.

TERRACINI, B., SHUBIK, P. and DELLA PORTA, G. - (1960)

A study of skin carcinogenesis in the mouse with single applications
of 9.10 - dimethyl 1.2 - benzanthracene at different dosages.

Cancer Res., 20, 1538.

WHITEHEAD, J. K. and ROTHWELL, K. - (1969)

The mouse skin carcinogenicity of cigarette smoke condensate :
fractionated by solvent partition methods.

Brit. J. Cancer, 23, 840.

WILLIS, - (1948)

Pathology of Tumours.

Butterworth, London.

WOLBACH, S. B. - (1936)

The latent period in experimental carcinogenesis.

Arch. Path., 22, 279.

WYNDER, E. L., GRAHAM, E. A. and CRONINGER, A. B. - (1953)

Experimental production of carcinoma with cigarette tar.

~~Cancer-Res.~~, 13, 855.

WYNDER, E. L. and HOFFMANN, D. - (1959)

A study of tobacco carcinogenesis. VII The role of higher polycyclic hydrocarbons.

Cancer, N.Y., 12, 1079.

WYNDER, E. L. and HOFFMANN, D. - (1961)

A study of tobacco carcinogenesis. VIII The role of the acidic fractions as promoters.

Cancer, N.Y., 14, 1306.

WYNDER, E. L. and HOFFMANN, D. - (1968)

Experimental tobacco carcinogenesis.

Science, N.Y., 162, 862.

WYNDER, E. L. and WRIGHT, G. F. - (1957)

A study of tobacco carcinogenesis. I The primary fractions.

Cancer, N.Y., 10, 255.

YAMAGIWA, K. and ITCHIKAWA, K. - (1918)

Experimental study of the pathogenesis of carcinoma.

J. Cancer Res., 3, 1.

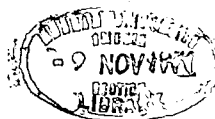

PLATE I

NORMAL EPIDERMIS

Section through the epidermis of the shaved area of skin
from an untreated albino mouse.

(Mag. = x 2,300)



PLATE 2

HYPERTROPHY

Section of epidermis taken from a mouse two days after painting with 20 - methylcholanthrene. The number of cells is similar to that found in untreated mice but the epidermal thickness is increased by cellular hypertrophy.

(Mag. = x 2,300)



PLATE 3

HYPERPLASIA

Section of epidermis taken from a mouse four days after painting with 20 - methylcholanthrene showing hyperplasia of the squamous cells with very little hypertrophy.

(Mag. = x 2,300)

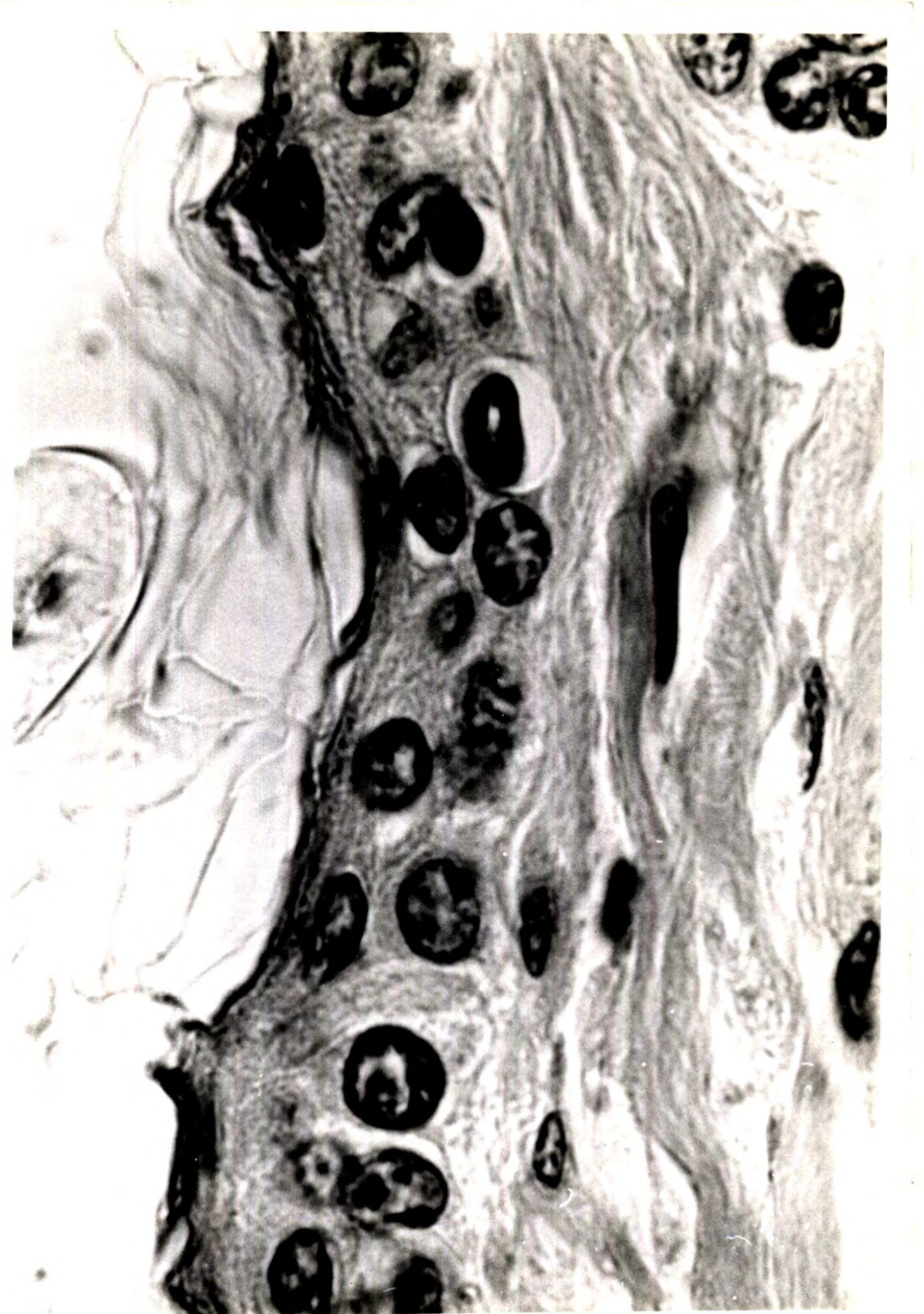

PLATE 4

HYPERPLASIA AND HYPERTROPHY

Section of epidermis taken from a mouse two days after painting with compound A₁ showing extensive hyperplasia and hypertrophy.

(Mag. = x 2,300)

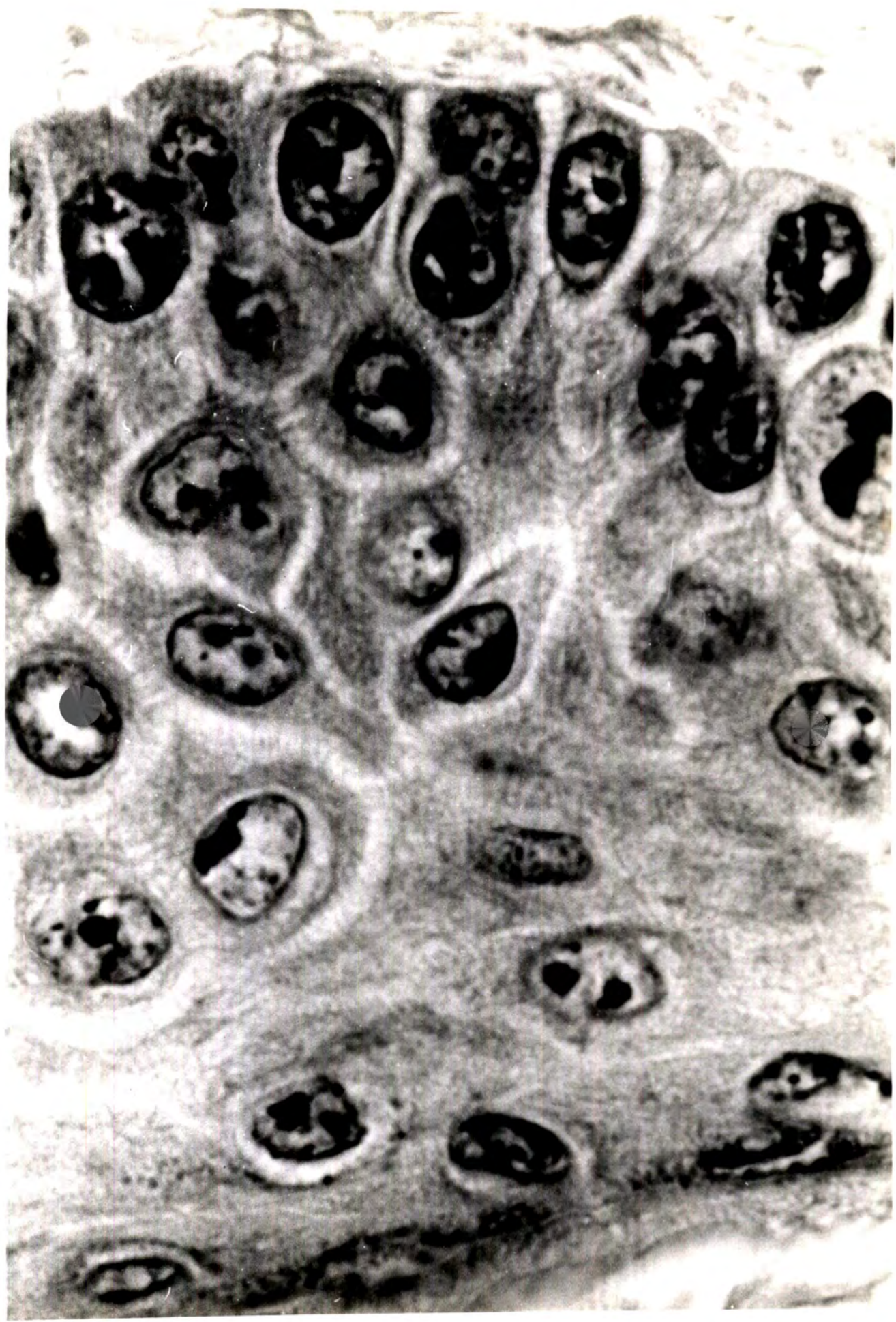

PLATE 5

Section of skin stained to show the basement membrane
marking the boundary between the epidermis and dermis.
Periodic acid-Schiff, gallocyanin and light green.

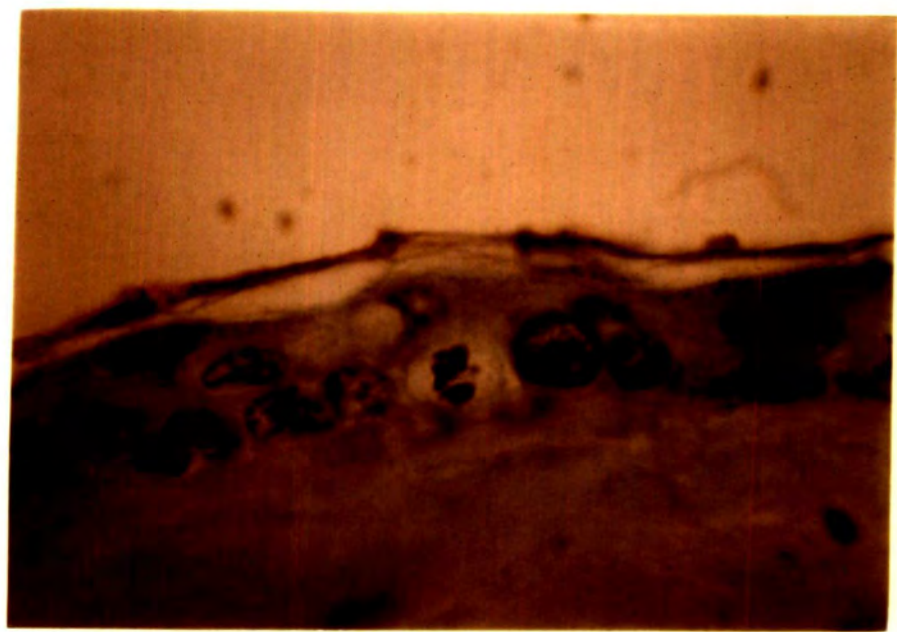

PLATE 6

Whole skin preparation from the shaved area of an untreated mouse. Toluidine blue.

PLATE 7

Whole skin preparation from a mouse treated with smoke condensate (100 mg. in 0.3 ml) showing engorgement of blood vessels and increased number of mast cells and inflammatory bodies.



PLATE 8

High power of mast cells in a whole skin preparation from an untreated mouse (Toluidine blue stained metachromatically).

PLATE 9

Disruption of mast cells with release of granules into the dermis of a mouse treated with smoke condensate.



PLATE 10

Technique used to shave an area on the back of the mice.



PLATE 11

Application of test substances by Jencóns repette.



PLATE 12

Excision of skin from the painted area.



PLATE 13

Skin samples removed from the painted area.



ST 19/2

PLATE 14

Measuring scale and square inscribed on the eyepiece graticule superimposed on a section of epidermis to illustrate how the measurements were made.

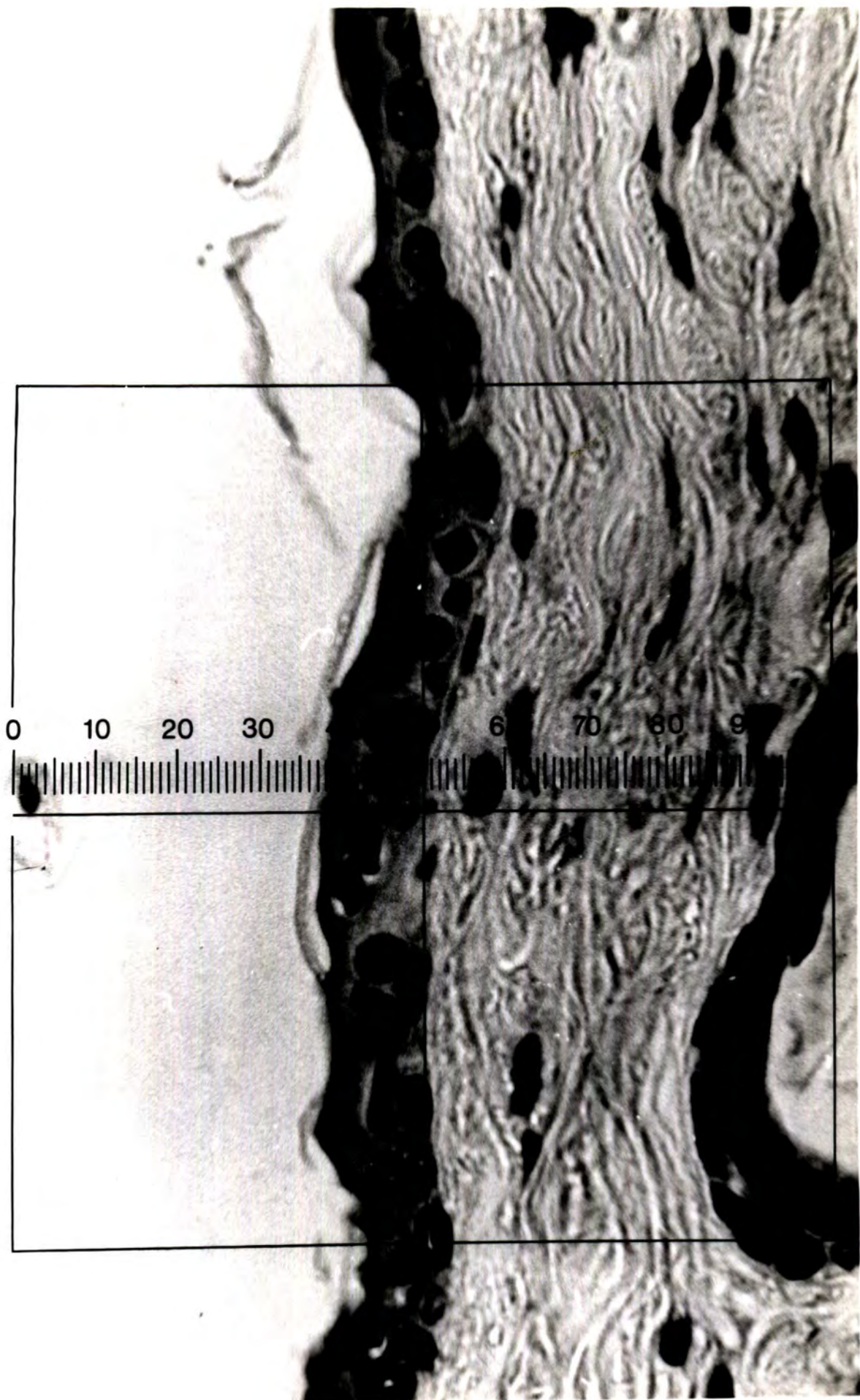

PLATE 15

Section of epidermis from a mouse painted with an irritant
and injected with colchicine three hours before sampling
to show arrested metaphase nuclei.



PLATE 16

Section of epidermis from a mouse injected with colchicine three hours before sampling. The presence of anaphase and telophase nuclei indicates that some cellular division is still in progress and the arrest of metaphase figures is not fully efficient.

