

## Durham E-Theses

---

### *The chemical constitution of some of the components of Tung oil*

Geoffrey G. Shone

#### How to cite:

---

Shone, Geoffrey G. (1962) The chemical constitution of some of the components of Tung oil. Masters thesis, Durham University.

#### Use policy

---

The full-text may be used and/or reproduced, and given to third parties in any format or medium, without prior permission or charge, for personal research or study, educational, or not-for-profit purposes provided that:

- a full bibliographic reference is made to the original source
- a <https://etheses.durham.ac.uk/id/eprint/10099/> is made to the metadata record in Durham E-Theses
- the full-text is not changed in any way

The full-text must not be sold in any format or medium without the formal permission of the copyright holders.

Please consult the [full Durham E-Theses policy](#) for further details.

A Thesis Entitled

THE CHEMICAL CONSTITUTION  
OF SOME OF THE  
COMPONENTS OF TUNG OIL

by

Geoffrey G. Shone

A candidate for the degree of Master of Science  
Durham Colleges in the University of Durham  
1962



## ACKNOWLEDGEMENTS

I wish to express my most sincere thanks to Professor W.K.R. Musgrave for his advice and constant encouragement, to the Physical Chemistry Section of the Tropical Products Institute for some of the infra-red and ultra-violet absorption spectra and the elemental analyses presented in this thesis, to Miss P.J. Rose for experimental assistance, to the Director of the Tropical Products Institute for permission to submit this work (which was carried out at the Institute), and to my wife for her patience during the winter evenings when the manuscript was being compiled.

## CONTENTS

1.	<u>INTRODUCTION</u>	1
1.1	Reason for the Examination of the Composition of the Unsaponifiable Material Present in Tung Oil.	3
1.2	Composition of Tung Oil.	5
1.21	Saponifiable material.	5
1.22	Unsaponifiable material.	7
2.	<u>EXPERIMENTAL</u>	10
2.1	General.	10
2.11	Materials.	10
2.12	Infra-red and ultra-violet absorption spectra and optical rotations.	10
2.2	Saponification.	11
2.21	Estimation of the efficiency of saponification.	12
2.3	Chromatographic Separation of the Component Unsaponifiables.	13
2.31	Preparation of thin layers of silicic acid.	13
2.32	Preparation of thin layers of aluminium oxide.	17
2.33	Thin layer chromatography of the isolated unsaponifiable material.	18
2.34	Column chromatography of the isolated unsaponifiable material.	28
2.341	Preparation of column.	28
2.342	Separation of component unsaponifiables.	29
2.343	Observations on the colour present in some of the fractions.	31
2.344	Attempted separation of the isolated unsaponifiables on charcoal.	35

2.4	Identification of the Isolated Unsaponifiable Materials.	36
2.41	Fraction IA (Possibly squalene).	36
2.42	Fraction II ( $\alpha$ -tocopherol).	38
2.43	Fraction III ( $\gamma$ -tocopherol).	48
2.44	Fraction IB (Artefact of $\gamma$ -tocopherol)	56
2.45	Fraction IV ( $\Delta^5$ -stigmasten- $3\beta$ -ol).	62
2.46	Fraction V (Glyceryl ester).	69
2.47	Fraction VI.	71
2.48	Carotenoid pigment.	72
2.5	Infra-red Absorption Spectra.	74
2.6	Ultra-violet and Visible Absorption Spectra.	81
3.	<u>DISCUSSION</u>	84
3.1	Saponification.	84
3.11	Prevention of oxidation during saponification.	84
3.12	Estimation of the efficiency of saponification.	86
3.2	Chromatography.	86
3.3	Identification of the Isolated Components.	95
3.31	Fraction IA (Possibly squalene).	95
3.32	Fraction II ( $\alpha$ -tocopherol)	97
3.33	Fraction III ( $\gamma$ -tocopherol).	101
3.34	Fraction IB (Artefact of $\gamma$ -tocopherol)	107
3.35	Fraction IV ( $\Delta^5$ -stigmasten- $3\beta$ -ol).	113
3.36	Fraction V (Glyceryl ester).	125
3.37	Fraction VI.	127
3.38	Carotenoid pigment.	127
4.	<u>SUMMARY</u>	128
5.	<u>REFERENCES</u>	131

1. INTRODUCTION

"Tung oil is used in China in both crude and boiled forms . . . . . junks are proofed and impregnated with tung oil . . . . . all woodwork, both inside and outside the home is protected with tung oil . . . . . (it) is used for oiled paper . . . . . for waterproofing fabrics . . . . . in some regions of China tung oil is also used as a fuel oil for lighting purposes and for soap manufacture."(1).

The main use for tung oil in the western world is in the formulation of high gloss and chemically resistant paints. At one time this oil was obtained almost exclusively from China but during the 1920-1930's other territories began growing the tung tree with a view to setting up a tung oil industry, e.g. Burma, United States of America, Nyasaland, and in some instances success was achieved. The present major tung oil producing countries are tabulated below.



Table I:      Production of tung oil for 1959  
                  (thousands of tons)<sup>(2)</sup>

China	75.0 *
United States	18.1
Argentina	15.7
Paraguay	3.4
Brazil	(1.6)
Madagascar	1.8
Nyasaland	1.3
Soviet Union	(0.8)

\* Unofficial estimate

The majority of these countries cultivate trees of the Aleurites fordii species which is said to "flourish in rocky areas and on poor soils. It requires a cool climate, but is very frost tender . . . .

An elevation of 2,800-3,500 feet, and a rainfall of about 50 inches is best suited to its growth."<sup>(3)</sup>.

In Nyasaland, however, trees of the related species, Aleurites montana, are more usually cultivated as

this species tends to flourish in the warmer climate where A. fordii does not do so well. The A. montana species "can thrive in a warmer climate and withstand heavier rainfall (than A. fordii) . . . . A rainfall varying from 70-110 inches and a maximum temperature of 96°F and a minimum of 43°F have not proved unfavourable to its growth . . . . It is frost tender."(3).

1.1 Reason for the Examination of the Composition of the Unsaponifiable Material Present in Tung Oil.

The paint industry employs a 'gelation' test in order to ensure that tung oils are unadulterated. This test (B.S.391 (1949)) involves the heating of a quantity of oil to 276±1°C and the recording of the time taken for gelation to occur. It is well known<sup>(4-7)</sup> that the gel time for oil from A. fordii nuts is very much shorter than that for oil from nuts of the A. montana species of Nyasaland origin (13-15 minutes in the former case, as opposed to 20-27 minutes in the latter). The reasons for this difference have not previously been fully investigated, though it has

been shown that the free fatty acid content does slightly affect the gel time of tung oils (5).

It was at one time thought that gel time varied with elaeostearate content, but this was later shown not to be the case (4,6,7).

Variations in the gel time of tung oils must be reflections of chemical composition. At the commencement of this work it was considered that the major variations in gelation time encountered when dealing with A. fordii and A. montana oils could probably be explained by (a) the presence/absence, or a variation in the quantities, of trace amounts of catalyst or inhibitor in the unsaponifiable material of either or both oils, or (b) a variation in glyceride composition, i.e. if a large quantity of tri-elaestearin were present in an oil, it is likely that this oil would gel at a faster rate than an oil containing less of this component, as there is a greater potential "three dimensional" structure.

This thesis is concerned with the separation of the unsaponifiable material found in tung oil

derived from the A. montana species, and the identification of the isolated components. One oil of the A. fordii species was also examined in less detail, and no qualitative difference found in the unsaponifiable content of oils from the two species. The gel times of samples of these oils enriched with added unsaponifiables have also been shown not to differ from the times of gelation of the original oils.

The first possible explanation for the observed difference in gel time of the two oils ((a) above) was therefore rejected. Work is at present in progress on the second possible explanation ((b) above).

## 1.2 Composition of Tung Oil

### 1.21 Saponifiable material

The saponifiable portion of tung oil (approximately 99.5 per cent of the oil) is composed of approximately 90 per cent fatty acids (Table II) and 10 per cent glycerol which are combined in the form of triglycerides.

There is, however, a small free fatty acid content and a corresponding quantity of mono- and/or di-glycerides due to hydrolysis of the oil after harvesting of the tung fruit.

Table II: Component fatty acids of tung oil (per cent)

	<u>Hilditch</u> <sup>(8)</sup>	<u>by V.P.C.</u> <sup>(9)</sup>
α-Elaeostearic (I)	65-82	77.0
Linolenic (II)	-	3.0
Linoleic (III)	9-15	9.1
Oleic (IV)	4-18	7.4
Stearic (V) )	4-6	( 1.3
Palmitic (VI) )		

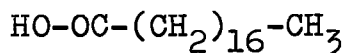

V

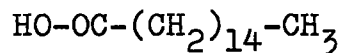
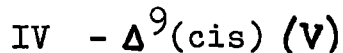
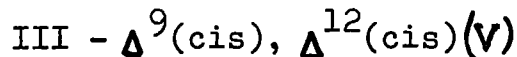
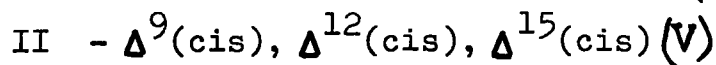
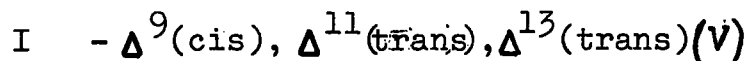

VI

## 1.22 Unsaponifiable material

There are few literature references to the composition of the unsaponifiable material which is present in tung oil to the extent of 0.3 - 0.76 per cent<sup>(10)</sup>.

In 1938 Bilger and Westgate<sup>(11)</sup> reported that a sterol (m.p. 130-136°C), capable of being precipitated by digitonin, was present to the extent of some 37 per cent of the unsaponifiable matter of this oil.

Tošić and Moore later (1945)<sup>(12)</sup> reported the carotenoid pigment content of the tung oil they examined to be 4 µg./g. oil (equivalent to approximately 0.1 per cent of the unsaponifiables). They also examined the unsaponifiable fraction for 'Vitamin E' activity, and found it to contain the equivalent of 2370 µg./g. oil of ferric chloride reducing substances, but biological tests showed the presence of a very low level of 'Vitamin E' (VII). The unsaponifiable material was then adsorbed on to

an alumina column and a 'Vitamin E containing fraction' eluted off with a petroleum spirit-ethanol mixture; this contained 444 µg./g. oil of 'unadsorbed' material which was shown biologically to contain a high concentration of 'Vitamin E'. No attempt was made to purify this fraction or to examine the nature of the 'Vitamin E'.

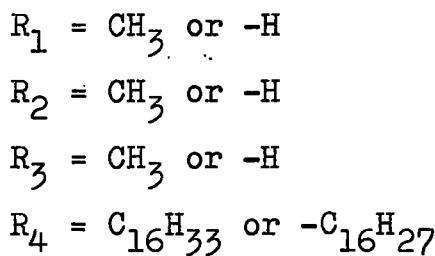
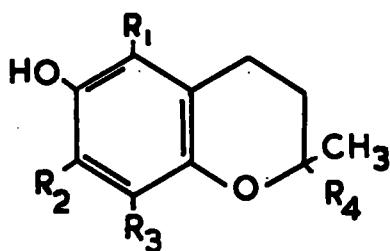

) see P.88

VII 'Vitamin E'  
(The tocopherols)

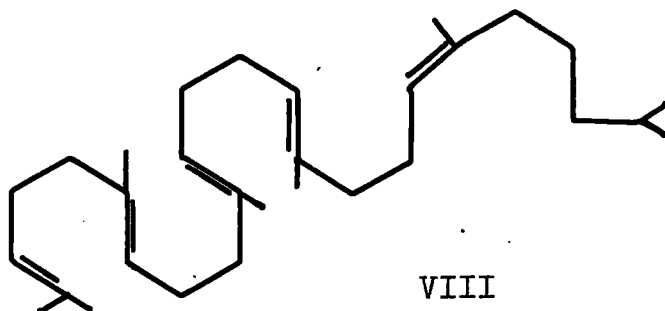

VIII

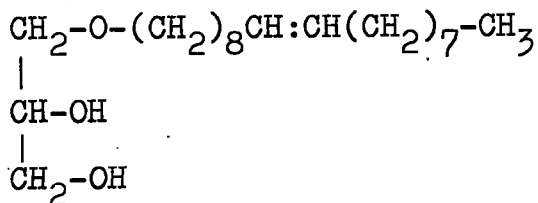

IX

Squalene (VIII) was reported by Dickhart<sup>(13)</sup> to occur to the extent of some 6 per cent and  $\alpha$ -glyceryl ether by Karnovsky and Rapson<sup>(14)</sup> to the extent of approximately 1.9 per cent (as selachyl alcohol (IX)), of the unsaponifiable material present in tung oil. Both these estimations are held to be highly suspect for the reasons put forward in Sections 3.31 and 3.36 respectively.

No other work has been reported on the composition of the unsaponifiable material present in tung oil.

## 2. EXPERIMENTAL

### 2.1 General

#### 2.11 Materials

The tung oil used in this work was obtained from Vipya Tung Estates, Nyasaland, and was derived (by expression) from nuts of the species Aleurites montana.

All solvents were of Analytical Reagent grade, unless otherwise stated, and were used without any preliminary treatment. The petroleum spirit fractions used were free from aromatic hydrocarbons, i.e. > 0.5 per cent aromatics.

#### 2.12 Infra-red and ultra-violet absorption spectra and optical rotations

The infra-red absorption spectra were obtained on approximately 1-2 per cent solutions in carbon disulphide (unless otherwise stated) using a Hilger H800 or a Perkin Elmer, model 137 Infracord, double beam spectrophotometer fitted with rock-salt optics.

The ultra-violet absorption spectra were measured on ethanolic solutions (unless otherwise stated) using either a Unicam SP500 or an Optica CF4 D.R.N.I., grating, double beam spectrophotometer.

Specific rotations were measured on 1-4 per cent solutions in chloroform (path length 5 cm.) using a Bellingham & Stanley (Model A) instrument.

## 2.2 Saponification

Tung oil (200 g.) was saponified for one hour, under an atmosphere of nitrogen and in the presence of 5 per cent pyrogallol (to prevent oxidation of any readily oxidisable compounds present<sup>(15)</sup>) using 12 per cent alcoholic potassium hydroxide (500 ml.). The reaction mixture was cooled and the (apparent) unsaponifiable matter extracted with diethyl ether after the addition of iced water; six extractions, each with 65 - 70 ml. ether were found to be necessary. The combined ether extracts were washed with distilled water and 10 per cent aqueous potassium hydroxide and then washed free from alkali with distilled water. The neutral ether extract was dried over anhydrous sodium sulphate and the solvent evaporated under nitrogen; the last few millilitres of ether were removed in a tared flask under reduced pressure, using a water bath at 65-75°C. The red-brown residue was weighed (820-840 mg.) dissolved in petroleum spirit

(b.p. 60-80°C), and made up to a standard volume.

## 2.21 Estimation of the efficiency of saponification

The original tung oil contained 70 per cent of  $\alpha$ -elaeostearic acid (as glyceride). This was determined spectrophotometrically by obtaining the extinction coefficient of a 1 per cent solution of the oil in cyclohexane at 268  $m\mu$ <sup>(16)</sup> and relating this to the extinction coefficient of pure  $\alpha$ -elaeostearic acid (m.p. 47-48°C), prepared by the method of Hoffmann et al<sup>(17)</sup>, at this wavelength ( $E_{1cm}^{1\%}$  1513). This value (70 per cent) was checked by determining the extinction coefficients at 269 and 271.5  $m\mu$  and using the method of Hoffmann et al<sup>(17)</sup> to calculate the elaeostearic acid content. The deviation in elaeostearate content from these three calculations was  $\pm 1$  per cent.

A measure of the efficiency of saponification was therefore made by determination of the conjugated triene content of the isolated unsaponifiables by obtaining the extinction coefficient at 268  $m\mu$  and relating this value to the extinction coefficient of  $\alpha$ -elaeostearic acid. This presumed that no conjugated

triene was present in the unsaponifiable matter as such.

### 2.3 Chromatographic Separation of the Component Unsaponifiables

The method of separation of the component unsaponifiables was developed using thin layer chromatography; the established system was then transferred to a column scale and the same solvent systems used as in the case of 'thin layers'.

#### 2.31 Preparation of thin layers of silicic acid

Silica gel, 100-200 mesh (Griffin & George Ltd.) (80 g.) and plaster of Paris (Hopkin & Williams Ltd.) (20 g.) were mixed into a slurry with distilled water, and layers of thickness  $0.20 \pm 0.02$  cm. were produced on glass plates (15 x 10 x 0.2 cm.) by spreading the slurry on to the plates (bounded by glass rods of diameter

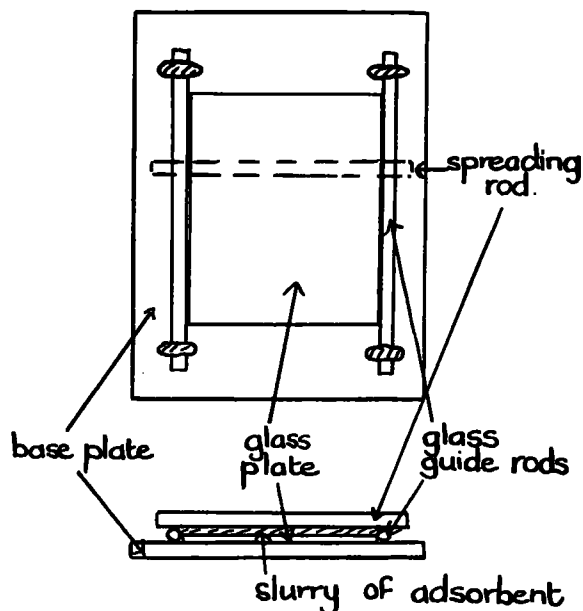

Fig. 1.

0.4 cm.) using a glass rod, as shown in Fig. 1. 100 g. material was found to be sufficient for ten plates.

The plates (now coated with the silica/plaster of Paris mixture) were placed in an oven (with the vent holes open, but not fitted for forced air circulation), at 100°C. for 1.5 - 2 hours. On removal from the oven, the plates<sup>x</sup> were allowed to cool in a vacuum dessicator over anhydrous calcium sulphate for several hours before use.

It was not absolutely necessary to remove the plates from the oven after two hours, and it was found that they could be left overnight at 100°C. without any change in the degree of activity, but the minimum drying time for reproducible constant activity was found to be 1.5 hours (Table III).

---

x The term 'plate' here and subsequently, refers to a glass plate coated with adsorbent layer; also, e.g. 'silica plate' refers to a glass plate coated with silica gel/plaster of Paris.

The activity (and variation therein) of the plates was determined by running approximately 2  $\mu$ g. quantities of the sodium salt of indo-phenol blue (phenol-indophenol), Sudan red, and butter yellow (p.dimethylaminoazobenzene (also known as dimethyl yellow)) as suggested by Stahl<sup>(18)</sup>, in benzene and 15 per cent ether/benzene (Table IV). It will be seen that the thin layers of silicic acid used in this work were slightly more active than those used by A. Seher<sup>(19)</sup> (Table V) and also than those referred to by E. Demole<sup>(20)</sup>.

Table III: Effect of variations in time of heating at 100°C. during preparation, on the activity of silica plates.

Heating Time (hr.)	$R_f$				
	1		1½	2	18
Eluent	$C_6H_6$	$C_6H_6$	15%E/ $C_6H_6$	15%E/ $C_6H_6$	15%E/ $C_6H_6$
Sudan Red	1.00	0.08	0.70	0.66	0.71
Butter Yellow	1.00	0.00	0.55	0.56	0.48
Indophenol Blue	-	0.00	0.05	0.04	0.04
$\alpha$ -tocopherol	1.00	-	0.77	0.78	0.80
$\gamma$ -tocopherol	1.00	-	0.64	0.65	0.66

E = Diethyl ether

Table IV: Degree of activity of silica plates using the accepted indicator colours.

Eluent	Rf			
	n-Hexane	C <sub>6</sub> H <sub>6</sub>	5%E/ C <sub>6</sub> H <sub>6</sub>	15%E/ C <sub>6</sub> H <sub>6</sub>
Sudan Red	0.00	0.08	0.33	0.71
Butter Yellow	0.00	0.00	0.15	0.48
Indophenol Blue	0.00	0.00	0.00	0.05

E = Diethyl ether

Table V: Thin layer silicic acid chromatography of  $\alpha$ - and  $\gamma$ -tocopherols - Rf. values.

	CHCl <sub>3</sub>		C <sub>6</sub> H <sub>6</sub>	
	Seher <sup>(19)</sup>	This work	Seher <sup>(19)</sup>	This work
$\alpha$ -tocopherol	0.56	0.35	0.72	0.39
$\gamma$ -tocopherol	0.41	0.21	0.50	0.28
Sudan red	-	0.07	-	0.09

2.32 Preparation of thin layers of aluminium oxide

Neutral aluminium oxide, activity grade 1, (M. Woelm) (90 g.) and plaster of Paris (Hopkin & Williams Ltd.) (10 g.) were mixed into a slurry with distilled water, and layers of thickness  $0.20 \pm 0.02$  cm. produced on glass plates as before. 100 g. of material was found to be sufficient for seven plates.

The activity of the plates was checked periodically by the procedure used in the case of the silica plates, but using 50 per cent diethyl ether/benzene as eluent (Table VI).

It is presumed that alumina and silica plates of varying degrees of activity could be prepared by exposure of the coated plates to differing relative humidities, but this was not investigated.

Table VI: Degree of activity of alumina plates using the accepted indicator colours (Eluent - 50%(C<sub>2</sub>H<sub>5</sub>)<sub>2</sub>O/C<sub>6</sub>H<sub>6</sub>)

	Rf
Sudan Red	0.89
Butter Yellow	0.13
Indophenol Blue	0.00
α-tocopherol	0.46
γ-tocopherol	0.27

2.33 Thin layer chromatography of the isolated unsaponifiable material.

Separation of the component unsaponifiables was attempted using both silica and alumina plates and various solvent systems (see Tables VIII - XII) as follows:-

The isolated unsaponifiable material (20-40 μg), dissolved in petroleum spirit (b.p. 40-60 or 60-80°C.) was spotted on to a base line 1.5 cm. from one end of a plate and the solvent allowed to evaporate for 1 - 2 minutes in the atmosphere. The plate was placed in a vertical position in a tank (16 x 25 x 12 cm.) containing 100 ml. of the chosen solvent mixture (benzene, 5 per cent ether/benzene, etc. - Tables VIII - XII) to a depth of approximately 1 cm., and

the solvent front allowed to run up the adsorbent to a point 10 cm. from the base line. The plate was then removed from the tank, the solvent evaporated in an oven at 100°C., and the separated components detected.

Concentrated sulphuric acid, dispensed on to the warm plate using a dropper, was found to be the most sensitive method of detection and was used on both silica and alumina plates throughout the work, unless otherwise stated (see Table VII).

The following spray methods of detections were tried:

1. 0.5 per cent fluorescein (sodium salt) in water. The plate was dried in an oven and then exposed to bromine vapour. Unsaturated components appeared as yellow spots on a pink-red background. Not as sensitive as sulphuric acid detection.
2. Saturated solution of antimony trichloride in chloroform. Plate heated with an infra-red lamp. Components appeared as coloured spots on a white background. Not as sensitive as sulphuric acid for the detection of some

components (e.g. tocopherol).

3. 0.05 per cent rhodamine B in ethanol. After drying, the plate was examined under ultra-violet light ( $\lambda$ , 3650 and 2537 Å). Dark blue spots appeared on a red background. Not very sensitive.
4. 6 per cent dodecamolybdophosphoric acid in ethanol. Dark purple spots on a yellow-green background given by unsaturated compounds on heating (infra-red lamp). Not as sensitive as sulphuric acid.

Table VII: Colour of spots on thin layer chromatograms before and after sulphuric acid detection.

<u>Component</u>	<u>Before</u>	<u>After</u>
Sudan Red	Red	
Butter Yellow	Red	
Indophenol Blue	Red	
Fraction IA (squalene ?)	not visible	orange-brown
" IB (tocopherol artefact)	" "	purple
" II ( $\alpha$ -tocopherol)	" "	yellow
" III ( $\gamma$ -tocopherol)	" "	yellow-green
" IV ( $\beta$ -sitosterol)	" "	orange-brown
" V (elaeostearin)	" "	dark brown

Separation of the component unsaponifiabiles  
was obtained using:

(a) Alumina plates and the following solvent mixtures -

1. Diethyl ether/petroleum spirit (b.p. 40-60°C)
2. Ethyl acetate/ " " "
3. Diethyl ether/benzene

Of these, the second and third appeared to give reasonably satisfactory separation of the components (Tables VIII, IX).

(b) Silica plates, with the following solvent mixtures -

1. Diethyl ether/petroleum spirit (b.p. 40-60°C)
2. Ethyl acetate/ " " "
3. Ethanol / " " "
4. Diethyl ether/benzene (together with benzene/petroleum spirit (b.p. 40-60°C)).

The third mixture was not acceptable as very pronounced streaking occurred. Diethyl ether/benzene gave the most satisfactory separation, followed by ethyl acetate/petroleum spirit. Tables X - XI give the Rf values obtained for the separated components using silica plates.

Table VIII:

Separation of the unsaponifiable material by thin layer chromatography on alumina plates using ethyl acetate/petroleum spirit mixtures.

		Rf						
Eluent		5%	10%	20%	30%	50%	80%	100%
Component	P.S.	E.A./P.S. E.A./P.S. E.A./P.S. E.A./P.S. E.A./P.S. E.A./P.S. E.A.						
Trace Components	5 components present	all at 0.95						
Purple Spot (tocopherol artefact)	0.03	0.79	0.95	0.95	0.95	0.95	0.95	0.95
Yellow Spot (tocopherol)	0.00	0.00	0.29	0.37	0.74	0.85	0.90	0.90
Orange Spot (sterol)	0.00	0.00	0.14	0.22	0.41	0.55	0.78	0.89
Residue								0.00

P.S. = Petroleum Spirit (b.p. 40-60°C.) : E.A. = Ethyl Acetate

Table IX: Separation of the unsaponifiable material on alumina plates using diethyl ether/petroleum spirit and diethyl ether/benzene mixtures.

Eluent Component		Rf		
		50% E/P.S.	100% E.	50% E/C <sub>6</sub> H <sub>6</sub>
Trace Components		-	-	-
Purple Spot (tocopherol artefact)		0.90		1.00
Yellow Spot (tocopherols)		0.45	1.00	0.46 (α) 0.27 (γ)
Orange Spot (sterol)		0.22	0.43-0.74	
Residue			0.00	

P.S. = Petroleum Spirit (b.p. 40-60°C.)

E. = Diethyl Ether

**Table X:** Separation of the unseparatable material on silica plates using diethyl ether/petroleum spirit and ethyl acetate/petroleum spirit mixtures.

Eluent Fraction	Rf									
	2.5%	15%	25%	45%	10%	15%	30%	50%	100%	
	E/P.S	E/P.S	E/P.S	E/P.S	E.A/P.S	E.A/P.S	E.A/P.S	E.A/P.S	E.A	
I	0.15	0.67	1.00							
II ( $\alpha$ -tocopherol)	0.09-	0.18-	0.35-							
	0.11	0.32	0.50	0.70	0.35	0.42	0.72	0.92	1.00	
III ( $\gamma$ -tocopherol)	0.00-	0.04-	0.20-							
	0.09	0.18	0.35	0.58	0.25	0.32	0.61	0.77	1.00	
IV (sterol)	0.00	0.00	0.00-							
			0.20	0.45	0.10	0.16	0.39		1.00	
V (elaeostearin)				0.00						

P.S. = Petroleum Spirit (b.p. 40-60°C.)

E. = Diethyl ether

E.A. = Ethyl Acetate

Table XI: Separation of the unsaponifiable material of tung oil on silica plates using petroleum spirit/benzene and diethyl ether/benzene mixtures

		Rf									
Eluent	Fraction	80% P.S/ C <sub>6</sub> H <sub>6</sub>	50% P.S/ C <sub>6</sub> H <sub>6</sub>	5%E/ C <sub>6</sub> H <sub>6</sub>	10%E/ C <sub>6</sub> H <sub>6</sub>	15%E/ C <sub>6</sub> H <sub>6</sub>	20%E/ C <sub>6</sub> H <sub>6</sub>	25%E/ C <sub>6</sub> H <sub>6</sub>	50%E/ C <sub>6</sub> H <sub>6</sub>	60%E/ C <sub>6</sub> H <sub>6</sub>	100% E
		(CH <sub>3</sub> ) <sub>2</sub> CO	CH <sub>3</sub> OH								
IA	(squalene ?)	0.70	1.00								
IB	(tocopherol artefact)	0.09	0.7- 0.8	1.00							
II	(α-tocopherol)			0.40	0.56	0.80					
III	(γ-tocopherol)			0.27	0.38	0.54	0.66	0.72	0.90	1.00	
IV	(β-sitosterol)			0.12	0.28	0.35	0.39	0.47	0.61	0.71	0.80
V	(elaeostearin)								0.22	0.3- 0.4	1.00
VI											0.00
											1.00

E. = Diethyl ether

P.S. = Petroleum Spirit (b.p. 40-60°C)

Table XII: Attempted separation of the unsaponifiable material on an alumina/plaster of Paris (90/10) column - Example of the thin layer chromatography of some of the fractions, on alumina plates.

Tube No.	Eluted off column with	Thin layer chromatography
339-372	50% E.A./P.S.	Sterol - Rf 0.00 - also 4 spots less polar than sterol (5% E.A./P.S.)
398-407	100% E.A.	Sterol - Rf 0.55 - also 3-4 spots less polar and 3 spots more polar than sterol (50% E.A./P.S.)

N.B. The original unsaponifiables showed only four spots when chromatographed using 50% E.A./P.S. (see Table VIII).

E.A. = Ethyl Acetate

P.S. = Petroleum Spirit (b.p. 40-60°C.)

It was decided not to proceed with the use of solvent mixtures involving ethyl acetate in view of the fact that traces of this compound in isolated fractions can give rise to spurious carbonyl absorption bands in the  $1730\text{ cm.}^{-1}$  region of the infra-red absorption spectra.

When separation of the isolated unsaponifiable material was attempted using an alumina column, decomposition of the components occurred, e.g. Table XII, tubes 398-407; these were eluted off an alumina/plaster of Paris column with ethyl acetate and the eluate contained eight components (by thin layer chromatography as in Table VIII), whereas the original isolated unsaponifiable matter showed only four spots when similarly chromatographed (Table VIII). Later work showed that tocopherols present in the unsaponifiables broke down to give many artefacts when chromatographed on alumina/plaster of Paris columns.

In view of the occurrence of the above phenomenon, it was decided not to use alumina for the separation of the component unsaponifiables, but to use silica/plaster of Paris and diethyl ether/benzene

(also benzene/petroleum spirit) mixtures, as in Table XI. The thin layer chromatography of the isolated unsaponifiable matter using these materials resulted in the mixture being resolved into seven components.

This system was then used in column form to separate the total unsaponifiable material isolated from 200 g. tung oil.

2.34 Column chromatography of the isolated unsaponifiable material

2.341 Preparation of column

Silica gel (20 g.) and plaster of Paris (50 g.) were mixed into a slurry with petroleum spirit (b.p. 40-60°C.) and poured into a cylindrical glass chromatographic column measuring 60 x 3.5 cm., (fitted with a sintered glass disc (which was covered with a circle of 'Whatman No. 1' filter paper) and a tap below the disc) containing a few millilitres of petroleum spirit and with the tap open; as the solid material moved down the column further quantities of the slurry were added until the solid phase packed down under the flow of organic phase to about 2 cm. from the top of the column.

2.342 Separation of the component unsaponifiables

The residue from the saponification stage (approximately 830 mg.) was dissolved in a few millilitres of petroleum spirit (b.p. 40-60°C.) and adsorbed on to the top of the column. A reservoir was then fitted, and the column eluted with solvent mixtures as in Table XIII. Acetone and methanol were found to be necessary to remove coloured constituents which were present in small quantity and had not been detected by thin layer chromatography.

Table XIII: Examples of the eluents used to separate the unsaponifiable material of tung oil on the main silica gel/plaster of Paris column.

<u>A: Oil 1M (12/1)</u>	<u>B: Oil 2M (6/7)</u>
400 ml. Benzene	600 ml. Benzene
100 ml. 3.5% Diethyl ether/ benzene	400 ml. 5% Diethyl ether/ benzene
500 ml. 5% Diethyl ether/ benzene	150 ml. 50% Diethyl ether/ benzene
100 ml. 10% Diethyl ether/ benzene	150 ml. Diethyl ether
100 ml. 20% Diethyl ether/ benzene	150 ml. Acetone
400 ml. 50% Diethyl ether/ benzene	Methanol
640 ml. Diethyl ether	
300 ml. Acetone	
Methanol	
Column hold-up 300 ml.	Column hold-up 300 ml.

Table XIV: Eluents used to separate the components of the first 3-4 tubes from the main column on a secondary silica gel/plaster of Paris column.

80% Petroleum Spirit (b.p. 40-60°C.)/benzene, to elute the first component IA (Rf 0.70 - Table XI)

50% Petroleum Spirit (b.p. 40-60°C.)/benzene, to elute the second component IB (Rf 0.7-0.8 - Table XI)

50 ml. fractions were collected using a Towers automatic fraction collector, and the purity and content of each fraction tube determined qualitatively by thin layer chromatography, using silica plates. Tubes were bulked on the basis of this information and the quantity of individual components determined by weighing after the evaporation of the solvent under water pump vacuum at 65-75°C. In the event of a tube containing two components, the content was weighed separately and the proportion of individual components determined; for example, in a case involving tocopherols, by paper chromatography and spectrophotometric estimation by the Emmerie and Engel method (see Section 2.42).

The results of the separation of the unsaponifiable matter of two A. montana oils are given in Tables XV and XVI.

2.343 Observations on the colour present in some of the fractions

The pale yellow colour which occurred in the first one or two tubes disappeared on standing for 16 hours (even at 0°C.) in unstoppered tubes, the eluate becoming colourless. This colour was presumably due to non-oxidised, non-polar carotenoid pigment.

The major portion of the coloured material (yellow-orange) was eluted off the column with the sterol, and it is presumed that this polar material could be oxidised carotenoids. The carotenoid pigment content of the unsaponifiable material is discussed in Sections 2.48 and 3.38.

The yellow band, which was brought down the column with the acetone front must be quite polar. The fraction accounted for less than 1 per cent of the unsaponifiables (Tables XV, XVI) and is not considered further.

The copper-green band, eluted from the column with the methanol front, is considered in Sections 2.47 and 3.37.

**Table XV:** Detailed examples of the chromatographic separation of the unsaponifiable material isolated from tung oil on silica gel/plaster of Paris columns

**A:** The separation of the unsaponifiables of oil IM (12/1)

Tube No. (50 ml. fractions)	Eluent	Weight (mg.)	Component	Weight (mg.)	%
1-4	C <sub>6</sub> H <sub>6</sub>	46	( Squalene (?)	9	1.1
5-7	"	64.3	Tocopherol Artefact	37	4.6
8	"	20.4	α-tocopherol	α -74.1	9.0
9-16	5%E/C <sub>6</sub> H <sub>6</sub>	284.8	α (9.8)+ γ (10.6) tocopherols	γ -295.4	35.9
17-29	5,10 & 20% E/C <sub>6</sub> H <sub>6</sub>	365	γ-tocopherol	365	44.4
			Sterol		
30-42	50%E/C <sub>6</sub> H <sub>6</sub> +100%E.	27.1	Elaeostearin	27.1	3.3
43	Acetone	6.1	Yellow-orange band	6.1	0.7
44	Methanol	9.4	Copper-green band	9.4	1.1
	Total	823			

Table XV: B: The separation of the unsaponifiables of oil 2M (6/7)

Tube No. (50 ml. fractions)	Eluent	Weight (mg.)	Component	Weight (mg.)	%
1-3	C <sub>6</sub> H <sub>6</sub>	64	{ Squalene (?)	12	1.7
4-6	"	60	{ Tocopherol Artefact	53	7.4
7	"	17	{ α-tocopherol	α -76	10.7
8-16	C <sub>6</sub> H <sub>6</sub> & 5%E/C <sub>6</sub> H <sub>6</sub>	243	{ α(16)+γ(1) tocopherol		
17	5% E/C <sub>6</sub> H <sub>6</sub>	10	{ γ-tocopherol	γ -246	34.5
18-22	5 & 50% E/C <sub>6</sub> H <sub>6</sub>	281	{ γ-(2) tocopherol and ) sterol (8) ) Sterol )	sterol - 299	4.2
23-26	50% E/C <sub>6</sub> H <sub>6</sub> + 100% E.	31	{ Sterol (10) + Elaeostearin (21)	elaeo'n - 21	3.0
27	Acetone	0	-		
28	"	1	Yellow band	1	0.1
29-30	Methanol	6	Copper-green band	6	0.8
	Total	713			

E = Diethyl ether

Table XVI: The composition (per cent) of the unsaponifiables of two A. montana tung oils

Fraction	Oil		LM	12/1	16/3	LM	average	3/11	LM	30/5	LM	2M
	Ref. No.	LM										
IA (squalene ?)	1.3	1.1	0.7	1.0						15.7		( 2.2
IB (tocopherol artefact)	3.9	4.6	3.1	3.9				8.9				( 6.8
II ( $\alpha$ -tocopherol)	47.0	( 9.0	8.9	9.0				10.4		7.3		( 10.7
III ( $\gamma$ -tocopherol)		( 35.9	36.4	36.2				29.4		28.2		( 34.5
IV ( $\beta$ -sitosterol)	44.4	44.4	46.3	45.0						43.3		( 42.0
V (elaeostearin)	1.7	3.3	3.4	2.8				516.0				( 3.0
Yellow band	0.6	0.7	0.4	0.6						4.7		( 0.1
Green band	0.9	1.1	1.2	1.1								( 0.8
Total	99.9	100.1	100.4	99.6				100.3		99.2		( 100.2
On column mg.	854.0	823.0	763.0					690.0		886.0		( 720.0
Off column mg. *	840.0	823.0	768.0					705.0		854.0		( 713.0
% partially saponified material	1.9	1.9	2.9					1.5				( 4.9
Remarks								pyro-gallol not used		unsaponifiables isolated 10 weeks before separation		

\* Based on the conjugated triene content of the unsaponifiables (see Section 2.21)

2.344 Attempted separation of the isolated unsaponifiables on charcoal

A single attempt to separate part of the unsaponifiable material from oil LM on a charcoal column was not pursued. Elution was carried out with ethyl acetate/petroleum spirit mixtures. The carotenoid pigment present contaminated all fractions and the tocopherol fractions contained more components (by thin layer chromatography on silica plates) than did the original unsaponifiable material. Tocopherol artefacts were formed by oxidation on the column presumably due to adsorbed oxygen.

## 2.4 Identification of the Isolated Components

### 2.41 Fraction IA

This material appeared to be homogeneous on chromatography on silica plates having the same Rf as commercial squalene (90 per cent, Practical - Eastman Chemical Company), i.e. 0.71 for 80 per cent petroleum spirit/benzene, (see Table XI). The spot was orange-brown in colour in both cases, after sulphuric acid detection. When the plate was placed in an oven at 100°C. for 1-2 hours after detection with sulphuric acid, the isolated material was observed to tail, and it appeared that a small quantity of a second component of similar polarity to the first could have been lying close behind the original orange-brown spot.

The infra-red spectra of this fraction showed absorption bands at  $\nu_{\max}$ . (CS<sub>2</sub>/Infracord), 1740 (small), 1370 (C-CH<sub>3</sub>), 1260, 1095, 1020, 805, (R<sub>1</sub>R<sub>2</sub>C = CHR<sub>3</sub>), 758, 720 cm<sup>-1</sup>; (CHCl<sub>3</sub>/Infracord), 1708, 1600 (C = C), 1460 (-CH<sub>2</sub>-), 1420 (C-CH<sub>3</sub>), 1370 (C-CH<sub>3</sub>), 1350 cm<sup>-1</sup> (Fig. 3).

The infra-red spectra of commercial squalene (90 per cent, Practical) gave absorption maxima at  $\nu_{\text{max}}$ . ( $\text{CS}_2$ /Infracord) 1730 (small), 1652 (C = C) 1367 (C- $\text{CH}_3$ ), 1320 (-CH-), 1148, 1106, 981, 831 ( $\text{R}_1\text{R}_2\text{C} = \text{CHR}_3$ ),  $740 \text{ cm}^{-1}$ ; ( $\text{CHCl}_3$ /Infracord) 1735, 1665, 1602, 1460 (- $\text{CH}_2$ -), 1420 (C- $\text{CH}_3$ ), 1375 (C- $\text{CH}_3$ ), 1150, 1108,  $986 \text{ cm}^{-1}$  (Fig. 3).

## 2.42 Fraction II

This fraction was found to be liquid in character, fairly viscous at normal laboratory temperatures, and soluble in petroleum spirit (b.p. 40-60°C.) and in ethanol.

The infra-red absorption spectrum showed absorption bands at  $\nu_{\max.}$ , 3578 (-OH), 1618 (arom. C = C), 1263 (= C-O-), 1211 (phenolic - OH), 1085 (cyclic ether  $>C_3$ ) $\text{cm}^{-1}$  (Fig. 4) and the ultra-violet absorption curve gave  $\lambda_{\max.}$  292  $\mu$  ( $E_{1\text{cm.}}^{1\%}$  72),  $\lambda_{\min.}$  260  $\mu$  (Fig. 11).

As 'Vitamin E' had previously been detected in the unsaponifiables of tung oil<sup>(12)</sup>, it seemed likely that this fraction was composed of one of the tocopherols.

### Preparation of the 3.5 dinitrophenylurethan derivative of the isolated material. (after Smith and Sprung<sup>(21)</sup>)

60 mg. of isolated material and 63 mg. 3.5 dinitrobenzazide (see below for the preparation of this reactant) were dissolved in 5 ml. dry toluene and heated under reflux for 2.5 hours. The colour of the solution changed from orange to yellow during the reaction.

The solvent was removed under vacuum and the resultant residue crystallised three times from 90 per cent ethanol, m.p. 146-147°C.

The derivative was dried at 110°C/0.05 mm. and sent for carbon and hydrogen analysis. Found, C, 67.63; H, 8.67 per cent.  $C_{36}H_{53}O_7N_3$  requires C, 67.56; H, 8.34 per cent.

Preparation of 3.5 dinitrobenzazide. (after Smith and Sprung<sup>(21)</sup>).

10 g. 3.5 dinitrobenzoyl chloride was dissolved in 30 ml. acetic acid and 3 g. sodium azide added with stirring - the temperature being kept below 45°C. Thirty minutes after the addition of all the azide the solid product was separated by centrifuging, and the liquid phase discarded. The product was washed with distilled water, dried in a vacuum desiccator, washed with petroleum spirit (b.p. 40-60°C.) and again dried. 110 mg. product was recovered, m.p. 100-103°C.

The preparation was repeated, but this time the reactants were allowed to stand for two days instead

of thirty minutes. 6 g. product was recovered of the same melting point range as previously.

Paper Chromatography of Fraction II.

1. Method recommended by the Vitamin E Panel (Analytical Methods Committee)<sup>(22)</sup>

Whatman No. 1 chromatographic paper was impregnated with zinc-amine solution (containing fluorescein) and dried for one hour in the atmosphere followed by three hours at 100°C. (The ammine salt is decomposed, on drying, to zinc carbonate.) 50 µl. of a solution of Fraction II in petroleum spirit (b.p. 60-80°C.) (containing 65 µg.) was applied in a narrow band to the paper (see Fig. 2) and the chromatogram developed in the ascending manner, using 30 per cent v/v benzene/cyclohexane, the chromatographic tank being kept in darkness.

After the solvent front had run for approximately 15 cm., the paper was removed from the tank and allowed to dry for one hour in the atmosphere. The paper was then impregnated with liquid paraffin (see Fig. 2), using a 3 per cent w/v solution of light liquid paraffin B.P. (Hopkin & Williams Ltd.) in

petroleum spirit (b.p. 60-80°C.), and the solvent allowed to evaporate. The paper was run in the second dimension using 75 per cent ethanol as the mobile phase. When the solvent had travelled approximately 10 cm. in the paraffin phase, the paper was removed from the tank and allowed to dry in the atmosphere.

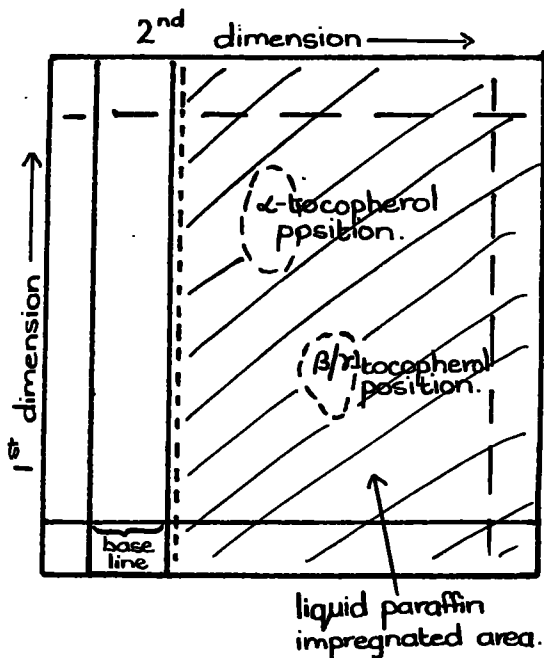

Fig. 2.

One spot was observed on the completed chromatogram when examined under ultra-violet light ( $\lambda$  3650Å) and this appeared in the  $\alpha$ -tocopherol position (Table XVII).

2. The method of Kodicek and Ashby<sup>(23)</sup>

Approximately 30  $\mu$ g. of Fraction II was applied to each of three strips of Whatman No. 1 chromatographic paper impregnated with liquid paraffin by drawing through a 5 per cent v/v solution in

petroleum spirit (b.p. 60-80°C.), and allowing the solvent to evaporate.

These papers were then run in the ascending manner, using the following solvent mixtures as mobile phases:-

1. 35 per cent ethyleneglycolmonoethyl ether/  
10 per cent n-proponal/30 per cent methonal/  
25 per cent water.
2. 15 per cent n-proponol/82 per cent methanol/  
3 per cent water.
3. 95 per cent methanol/5 per cent water.

After removal from the tanks, the chromatograms were air dried, sprayed with a saturated solution of antimony trichloride in chloroform (approximately 24 per cent) and heated with an infra-red lamp. The material appeared as a single yellow spot on a white background and in the position reported for  $\alpha$ -tocopherol (Table XVII).

A sample of commercial  $\alpha$ -tocopherol appeared in identically similar positions.

3. The method used by Harrison, et al<sup>(24)</sup>

Approximately 30 µg. of Fraction II was chromatographed by the ascending method on Whatman No. 1 paper impregnated with vaseline (2.5 per cent w/v in ether/air dried) and using 77 per cent ethanol as mobile phase.

The material appeared in the α-tocopherol position (Table XVII) after detection with approximately 6 per cent dodeca-molybdophosphoric acid in ethanol and heating with an infra-red lamp. Commercial α-tocopherol behaved in an identically similar manner.

Table XVII: Paper chromatography of isolated α-tocopherol - Rf values.

Method	Isolated material	Literature values
1. Vitamin E Panel -		
1st dimension	0.70	0.77 <sup>(22)</sup>
2nd dimension	0.21	0.28
2. Kodicek & Ashby -		
1st solvent system (A)	0.17	0.15 <sup>(23)</sup>
2nd solvent system (B)	0.59	0.58
3rd solvent system (C)	0.40	-
3. Harrison et al	0.47	0.55 <sup>(24)</sup>

Attempted preparation of the o-quinone

Oxidation with nitric acid under the conditions used by Eggitt and Norris<sup>(25)</sup> failed to produce an o-quinone.

Method: To a solution containing 2.28 mg. Fraction II in 10 ml. chloroform, 1 ml. nitric acid (A.R.) was added. After shaking for ten seconds the organic phase was drawn off and the absorption spectrum in the 400-600 m $\mu$  range obtained (against a blank prepared in a similar manner). The chloroform phase was very pale yellow in colour and showed no absorption maximum in this range.

A sample of commercial  $\alpha$ -tocopherol (Eastman Chemical Co.) was treated in like manner, and gave a similar result.

Attempted preparation of the nitroso compound

Reaction with nitrous acid failed to give a nitroso compound absorbing in the 400-450 m $\mu$  range<sup>(25)</sup>.

Method: To 0.98 mg. Fraction II in 5 ml. ethanol were added 0.2 ml. acetic acid, 3 ml. sodium nitrite solution (2 per cent in water), 2 ml. potassium hydroxide solution (20 per cent in water), a small

quantity of anhydrous sodium sulphate, and 10 ml. cyclohexane. After shaking for one minute the organic layer was removed and its absorption in the 300-450  $\mu$  range obtained against a blank prepared in a similar manner. A low absorption maximum was obtained at 365  $\mu$ .

A sample of commercial  $\alpha$ -tocopherol also gave a negative result.

Preparation of the 3.5 dinitrophenylurethan of commercial  $\alpha$ -tocopherol

This was prepared by the same procedure as that used for the isolated material, using 94 mg. of the commercial material and a 1.5 hour reflux time. The m.p. of the derivative after crystallisation three times from 90 per cent ethanol was 146.5-147.5°C.

Mixed melting point of the 3.5 dinitrophenylurethans of the isolated and commercial  $\alpha$ -tocopherols

Isolated material - 146-147°C.

Commercial material - 146.5-147.5°C.

Mixed (50/50) m.p. - 146-147°C.

Infra-red and ultra violet absorption spectra of commercial  $\alpha$ -tocopherol were identical with those of the isolated material ( $E_{1\text{cm.}}^{1\%}$  at  $\lambda_{\text{max.}}$  (292  $\mu$ )<sup>73</sup>) (Fig. 4).

### Purity of the isolated material

The purity of the isolated material was established by:

1. The extinction coefficient at 292 m $\mu$  (see above and Table XXV).
2. The chromatographic methods referred to above, i.e. thin layer and paper chromatography.
3. The ferric chloride/ $\alpha\alpha'$ -dipyridyl method of Emmerie and Engel<sup>(26)</sup>, using the method recommended by the Vitamin E Panel (but omitting the paper chromatography)<sup>(22)</sup>.

### Summary of method (3):

Approximately 30  $\mu\text{g}$ . (weight known accurately) of the isolated material (Fraction II) in 25  $\mu\text{l}$ . of ethanol was run into a "Quickfit" test tube and 3 ml. ethanol added. (The rest of the procedure was carried out in very dim artificial light.) To this solution was added 0.5 ml.  $\alpha\alpha'$ -dipyridyl solution (0.5 per cent in ethanol) followed by 0.5 ml. ferric chloride solution ( $\text{FeCl}_3 \cdot 6\text{H}_2\text{O}$  - 0.2 per cent in ethanol) and the extinction at 520 m $\mu$

determined exactly two minutes after addition of the ferric chloride solution, against a blank prepared in a similar manner. The determination was done in duplicate.

$$\text{Purity (\%)} = \frac{E \times F}{W} \times 100$$

Where E = net extinction measured

F = spectrophotometric factor for 4 ml.  
= 98 for  $\alpha$ -tocopherol

W = Weight of fraction taken

Examples of purity obtained for Fraction II from various separations

<u>Column</u>	<u>Purity</u>
6/7	77 per cent
6/7 repeat	105 per cent
12/1	71 per cent
16/3	72 per cent
3/11	72 per cent
Commercial	86 per cent

These figures are within the range which is considered acceptable by the Vitamin E Panel for 100 per cent pure  $\alpha$ -tocopherol determined by this method<sup>(22)</sup>.

### 2.43 Fraction III

This fraction was also found to be a fairly viscous liquid, soluble in petroleum spirit (b.p. 40-60°C.) and in ethanol.

The infra-red and ultra-violet absorption spectra showed the following absorption bands -

$\nu_{\max.}$ , 3509 (-OH), 1618 (C=C), 1376 (C-CH<sub>3</sub>), 1239 (=C-O), 1220 (phenolic-OH), 1080 (cyclic ether >C<sub>3</sub>) cm.<sup>-1</sup>;  $\nu_{\max.}$  (Infracord/CHCl<sub>3</sub>), 1470 (CH<sub>2</sub>-) 1428 (C-CH<sub>3</sub>), 1380 (C-CH<sub>3</sub>);  $\lambda_{\max.}$  297 m $\mu$  (E<sub>1cm.</sub><sup>1%</sup> 96)  $\lambda_{\min.}$  260 m $\mu$ . (see Figs. 5 and 11).

#### Preparation of the 3.5 dinitrophenylurethan derivative of the isolated material

The procedure used was the same as that in Section 2.42<sup>(21)</sup>, using 244 mg. isolated material in 11 ml. toluene and a reflux time of two hours. After three crystallisations from 90 per cent ethanol a m.p. 156-157.5°C. was obtained.

The product was dried at 110°C./0.05 mm. for approximately five hours. Found, C, 67.48; H, 8.74 per cent. C<sub>35</sub>H<sub>51</sub>O<sub>7</sub>N<sub>3</sub> requires C, 67.17; H, 8.21 per cent.

Preparation of the 3.5 dinitrobenzoate of the isolated material

To 140 mg. isolated material in 6 ml. dry toluene, 0.3 ml. dry pyridine was added, together with 121 mg. 3.5 dinitrobenzoyl chloride. The reaction mixture was heated under reflux for forty hours. (Thin layer chromatography on silica plates, using 10 per cent ether/benzene, after four and sixteen hours reaction time, showed the presence of large quantities of original material and only a small amount of product at Rf 0.95. After forty hours only a small quantity of original material was detected.)

After evaporation of the solvent, the residue was chromatographed on a silica column, using benzene and ether/benzene mixtures. 104 mg. crude product was obtained (74 per cent yield). Crystallisation from ethanol (twice) yielded pure product of m.p. 94-96°C., which was dried at 80°C./0.05 mm. Found, C, 68.82; H, 8.77 per cent.  $C_{35}H_{50}O_7N_2$  requires C, 68.81; H, 8.25 per cent.

Paper Chromatography of Fraction III

1. When chromatographed by the two-dimensional method recommended by the Vitamin E Panel (see Section 2.42<sup>(22)</sup>) a single spot was observed in the  $\beta/\gamma$ -tocopherol position (Table XVIII).
2. Partition chromatography using liquid paraffin impregnated paper (Kodicek and Ashby<sup>(23)</sup>) - see Section 2.42) produced a single spot of the Rfs given in Table XVIII.
3. When chromatographed on paper impregnated with vaseline<sup>(24)</sup> (see Section 2.42) the material appeared at Rf 0.87 (77 per cent ethanol as mobile phase) and 1.00 (absolute ethanol).

Table XVIII: Paper chromatography of isolated  $\gamma$ -tocopherol  
- Rf values

Method	Isolated material	Literature values
1. Vitamin E Panel -		
1st dimension	0.43	0.38 <sup>(22)</sup>
2nd dimension	0.44	0.48
2. Kodicek & Ashby -		
1st solvent system (A)	0.32-0.39 (streak)	0.26 <sup>(23)</sup>
2nd solvent system (B)	0.75	0.72
3rd solvent system (C)	0.66	-
3. Harrison et al <sup>(24)</sup>	0.87	-

### Preparation of the o-quinone

Oxidation of 2.03 mg. Fraction III in 10 ml. chloroform with 1 ml. concentrated nitric acid, as in Section 2.42<sup>(25)</sup>, gave a permanent red o-quinone,  $\lambda_{\max.}$ , 480 m $\mu$ ,  $E_{1\text{cm.}}^{1\%}$  32 (assuming quantitative conversion to the o-quinone) (Table XXVIII).

Preparation of the o-quinone in quantity by the above method but using 45 mg. of isolated material, gave a  $\lambda_{\max.}$  466 m $\mu$  ( $E_{1\text{cm.}}^{1\%}$  18) and infra-red absorption bands at  $\nu_{\max.}$ , 1735; 1677 (C=O), 1648 (C=O), 1630, 1376 (C-CH<sub>3</sub>), 1318, 1274 (=C-O), 1167, 1104 (cyclic ether >C<sub>3</sub>) 902 (Fig. 7).

### Preparation of the nitroso compound

A yellow nitroso compound was formed when 1.28 mg. material was reacted with nitrous acid, using the procedure described in Section 2.42<sup>(25)</sup>. This gave  $\lambda_{\max.}$ , 420 m $\mu$  ( $E_{1\text{cm.}}^{1\%}$  59),  $\lambda_{\min.}$ , 353 m $\mu$ , together with other maxima and minima (see Fig. 12).

The preparation of the nitroso compound was repeated using 567  $\mu$ g. of isolated material. 28  $\mu$ g. of the product was chromatographed on zinc carbonate impregnated paper, using 30 per cent benzene/cyclohexane

in the first dimension and, after impregnation with liquid paraffin, 93 per cent ethanol in the second dimension. A single spot was observed (Table XIX).

Table XIX: Paper chromatography of the nitroso derivatives of  $\beta$ - and  $\gamma$ -tocopherols

	Rf(1st dimension)	Rf(2nd dimension)
isolated $\gamma$ -tocopherol	0.22	0.22
$\beta$ -tocopherol ) literature	( -	0.415
$\gamma$ -tocopherol ) values <sup>(27)</sup>	( -	0.192

Condensation of the isolated material with p-nitrobenzene-diazonium chloride (after Quaife<sup>(28)</sup>)

0.61 mg. isolated material was dissolved in 2 ml. ethanolic sodium hydroxide (10 per cent 0.5N aqueous NaOH in ethanol) and cooled in iced water. Addition of 1.5 ml. of an ice cold arbitrary solution of p-nitrobenzenediazonium chloride (prepared by mixing p-nitroaniline with dilute hydrochloric acid and aqueous sodium nitrite) produced an immediate red colouration. The pH of the solution needed slight adjustment with dilute sodium hydroxide to 6-6.5, after which the azotocopherol was extracted into

7 ml. petroleum spirit (b.p. 80-100°C.). The extract was dried with anhydrous sodium sulphate.

The ultra-violet/visible absorption spectrum of this extract, against a blank prepared in a similar manner, showed maxima at 386 ( $E_{1\text{cm.}}^{1\%}$  198) and 532 ( $E_{1\text{cm.}}^{1\%}$  76) m $\mu$ ;  $\lambda$  min., 458 m $\mu$ .

Colour test which differentiates between  $\beta$ - and  $\gamma$ -tocopherols

Approximately 30  $\mu$ g. of the isolated material was spotted on to chromatographic paper and sprayed with a solution of 1 per cent ceric sulphate in 35 per cent sulphuric acid; a violet-blue colouration was produced (indicative of  $\gamma$ -tocopherol) rather than a brown colour, which is formed in the case of  $\beta$ -tocopherol<sup>(19)</sup>.

Preparation of the 3.5 dinitrophenylurethan of commercial  $\gamma$ -tocopherol

76 mg. commercial  $\gamma$ -tocopherol was reacted with 3.5 dinitrobenzazide as in Section 2.42. After crystallisation of the derivative five times from 90 per cent ethanol a m.p. 155.5°C. was obtained.

Mixed melting point of the 3.5 dinitrophenylurethans  
of the isolated and commercial  $\gamma$ -tocopherols

Isolated material	-	156-157.5°C.
Commercial material	-	155.5°C.
Mixed m.p. (50/50)	-	156-157°C.

Infra-red and ultra-violet absorption spectra of  
commercial  $\gamma$ -tocopherol

These were identical with those of the isolated material ( $E_{1\text{cm.}}^{1\%}$  at  $\lambda_{\text{max.}}(296 \text{ m}\mu) = 93$ ) (Fig. 5).

Purity of the isolated material

This was established by (1) the extinction coefficient at 296 m $\mu$  (see above and Table XXVII), (2) the chromatographic methods referred to above, i.e. thin layer and partition chromatography (Section 2.42) and (3) the ferric chloride  $\alpha$ 'dipyridyl method recommended by the Vitamin E Panel (but omitting the paper chromatography)<sup>(22)</sup>. The method used was the same as that used in the case of Fraction II (Section 2.42), the spectrophotometric factor being 90 in this case.

Examples of the purity obtained for Fraction III  
from various separations

6/7	98 per cent
12/1	86 per cent
12/1 (repeat)	78 per cent
3/11	97 per cent

These figures are within the range which is considered acceptable by the Vitamin E Panel for 100 per cent pure  $\gamma$ -tocopherol determined by this method<sup>(22)</sup>.

2.44 Fraction IB

This pale yellow viscous liquid gave infra-red and ultra-violet absorption bands at  $\nu_{\max.}$ , 3540 (-OH) (Infracord), 1732, (-C=O), 1615 (-C=C-), 1373 (-C-CH<sub>3</sub>), 1242 (=C-O-), 1220 (phenolic -OH) 1094, 1085 (cyclic ether >C<sub>3</sub>);  $\lambda_{\max.}$ , 295 m $\mu$  ( $E_{1\text{cm.}}^{1\%}$ . 73);  $\lambda_{\min.}$ , 263 m $\mu$  (Figs. 6 and 11). These spectra are, in certain respects, similar to those of  $\gamma$ -tocopherol, though some bands are not of such great intensity or are slightly displaced. The occurrence of the -C=O group suggests that this may be an oxidation product of one of the tocopherols (see Section 3.34).

Paper Chromatography

1. When chromatographed in two dimensions (after Vitamin E Panel - see Section 2.42<sup>(22)</sup>) no spot was produced in the liquid paraffin impregnated area.
2. Partition chromatography by the method used by Harrison et al<sup>(24)</sup> on vaseline impregnated paper gave the results shown in Table XX.

Table XX: Partition chromatography on vaseline impregnated paper using 77 per cent and 100 per cent ethanol.

Fraction	Rf values	
	<u>77% Ethanol</u>	<u>100% Ethanol</u>
II ( $\alpha$ -tocopherol)	0.48	1.00
III ( $\gamma$ -tocopherol)	0.87	1.00
IB (single spot produced)	0.00	0.56

Formation of a quinone of the isolated material

1. When 2 mg. isolated material, dissolved in 10 ml. chloroform, was oxidised with concentrated nitric acid as in Section 2.42 (but shaken for 15 seconds) a red organic phase was obtained of  $\lambda_{\text{max.}}$ , 465 m $\mu$  in the 400-500 m $\mu$  region ( $E_{1\text{cm.}}^{1\%}$ , 16).

2. The above procedure was repeated using 22 mg. isolated material and the infra-red absorption spectra of the product obtained:  $\nu_{\text{max.}}$  (Infracord/CS<sub>2</sub>), 1735, 1680 (C=O), 1650 (C=O), 1378 (C-CH<sub>3</sub>), 1320, 1277 (=C-O), 1261, 1168, 1104 (cyclic ether  $>C_3$ ), 903, 808 cm<sup>-1</sup> (see Fig. 7);  $\nu_{\text{max.}}$  (Infracord/CHCl<sub>3</sub>), 1594, 1460 (-CH<sub>2</sub>-), 1398 cm<sup>-1</sup>, c.f. infra-red spectrum of o-quinone of  $\gamma$ -tocopherol (Fig. 7).

Air Oxidation of the isolated material

Air was passed through a solution of the material (17 mg. in 10 ml. chloroform) for several days.

A colour change from very pale yellow to deep orange-red was observed. The infra-red absorption spectrum of this residue showed a similar absorption pattern to that of the original material, but the intensity of several bands was changed.

When the residue from the air oxidation was chromatographed on a silica column, the main fraction obtained was original material, but a deep red band remained at the top of the column and was unmoved by benzene (the o-quinone of  $\gamma$ -tocopherol was also retained at the top of a silica column as a deep red band under these conditions).

Attempted preparation of this compound from  $\gamma$ -tocopherol by air oxidation

Air was drawn through a solution of 50 mg.  $\gamma$ -tocopherol in approximately 10 ml. ethanol for 30 hours. Thin layer chromatography on silica plates using petroleum spirit/benzene (50/50) gave unchanged  $\gamma$ -tocopherol of Rf. 0.18 as the main component, and

a purple spot (after detection) of Rf 0.84 (Rf 0.09 in 80/20 petroleum spirit/benzene).

The ethanol was removed under vacuum and the reaction mixture chromatographed on a silica column using petroleum spirit/benzene (50/50) to elute the 'purple spot' material and diethyl ether/benzene (50/50) to recover the unchanged  $\gamma$ -tocopherol, 3 mg. 'purple spot' material was isolated; thin layer chromatography, using the solvent systems referred to above, gave Rf values of 0.80 and 0.09.

The infra-red absorption spectrum on this 3 mg. material on a sodium chloride disc (Infracord) gave very weak absorption bands, due to insufficient material being available, but it will be seen from Fig. 6 that they exactly coincide with the absorption bands of Fraction IB.

Attempted reduction of Fraction IB with ascorbic acid

1. Method I (after Boyer<sup>(29)</sup>)

8.3 mg. isolated material was dissolved in approximately 8 ml. ethanol and 2 ml. 10 per cent aqueous ascorbic acid added. After allowing to stand for 20 minutes (duplicate for 80 minutes), approximately

2 ml. water was added and the material extracted with petroleum spirit (b.p. 40-60°C). The extract was dried over anhydrous sodium sulphate and then subjected to thin layer chromatography on silica plates using benzene as eluent. In both cases only original material was found to be present (Rf 1.00) i.e. no tocopherols were formed.

2. Method II (after Harrison et al<sup>(24)</sup>)

8.3 mg. isolated material was dissolved in 40 ml. 80 per cent ethanol which contained sufficient acetic acid to give a pH of 3.2. Approximately 200 mg. ascorbic acid was added, and the solution allowed to stand for 30 minutes. The material was extracted and chromatographed as in Section 2.42 and only one spot was observed (Rf 1.00).

3. Method III (after Bouman and Slater<sup>(30)</sup>)

8.3 mg. isolated material was dissolved in approximately 3 ml. ethanol and 1 ml. hydrochloric acid and 200mg. ascorbic acid added. The solution (which was pale orange-red in colour) was refluxed for 30 minutes, cooled, approximately 6 ml. ethanol and 3 ml. aqueous potassium hydroxide (containing

4.4 g. KOH) added, and the mixture heated under reflux for 10 minutes. The orange-red reaction mixture was cooled, 80 ml. water added and extracted with petroleum spirit (b.p. 40-60°C.). The extract was weighed after removal of the solvent, and no residue was found in the flask. All the coloured material remained in the aqueous phase.

2.45 Fraction IV

This fraction was found to be composed of a white solid together with trace quantities of red pigment. The solid was freed from pigment by crystallisation from petroleum spirit (b.p. 40-60°C.) at -80°C; crystallisation from ethanol and then from petroleum spirit yielded white needle-like crystals of m.p. 134.5-135°C. and  $[\alpha]_D^{22}$ , -40.

Infra-red and ultra-violet absorption spectra gave the following bands (Figs. 8 and 13) -  $\nu$  max., 3582 (-OH), 1666 (-C=C-), 1376, 1367 (inflexion) (-C-CH<sub>3</sub> and C-(CH<sub>3</sub>)<sub>2</sub>), 1053 (-OH (primary or secondary)), 832, 795 (R<sub>1</sub>R<sub>2</sub>C = CHR<sub>3</sub>);  $\lambda$  max., 204 m $\mu$  ( $E_{1\text{cm}}^{1\%}$  64;  $\epsilon_{204}$  2,650 (Table XXI)).

Table XXI: Molecular extinction coefficients of  $\beta$ -sitosterol.

	$\lambda$ max.	$\epsilon$ max.	$\epsilon_{210}$	$\epsilon_{215}$	$\epsilon_{220}$
Previously reported <sup>(31)</sup>	203	2,800	1,600	750	350
This work -					
Isolated material	204	2,650	1,520	540	223
Commercial material	204	2,168	1,237	466	220

Molecular Weight (Rast method)

An impure specimen of the isolated material (m.p. 130.5-132°C.) was used for this determination; while giving an incorrect result the order of the molecular weight was then known.

The depression of the melting point of camphor using 1-2 mg. isolated material (in duplicate) was determined and the molecular melting point depression determined using naphthalene. This gave a molecular weight of 323 for the impure material.

Colour tests

1. Salkowski test for steroids - When concentrated sulphuric acid was added to a solution of the isolated compound in chloroform, an immediate red colouration was produced.
2. Liebermann-Burchard test for steroids - The addition of concentrated sulphuric acid and acetic anhydride to a solution of the isolated material in chloroform gave a positive result, the colour produced changing quite rapidly from red to blue, to green on standing, and finally to brown-green after standing for 18 hours.

Formation of a digitonide

A saturated solution of digitonin, in 90 per cent ethanol, when added to a solution of the isolated material in the same solvent produced an immediate white turbidity on shaking, followed by a definite white precipitate.

A solution of cholesterol gave an identical result when treated in a similar manner.

Purity of the isolated material

The isolated material appeared to be homogeneous when subjected to thin layer chromatography and the partition chromatographic methods of Kodicek and Ashby<sup>(23)</sup> (method and solvent systems as in Section 2.42) (Table XXII).

Table XXII: Paper chromatography of the isolated  $\beta$ -sitosterol (after Kodicek and Ashby) - Rf values.

	Isolated material	Literature values <sup>(23)</sup>
1st solvent system (A)	0.00	0.00
2nd solvent system (B)	0.49	0.51
3rd solvent system (C)	streaked	0.42

Elemental Analysis

A sample of the pure material (m.p. 134.5-135°C.) was dried at 110°C./0.05 mm. for 6-7 hours. Found, C, 82.67; H, 12.41; O, 5.08 per cent.

$C_{29}H_{50}O - \frac{1}{2}H_2O$  requires C, 82.20; H, 12.13; O, 5.67 per cent. It was not found possible to remove this water of crystallisation (see P.123).

Preparation of the derivatives of the isolated material

1. Benzoate - To 77 mg. isolated material in 5 ml. dry benzene were added 0.3 ml. dry pyridine and 0.15 ml. benzoyl chloride. The reaction mixture was heated under reflux for 3 hours. Thin layer chromatography (silica plates/benzene) showed that the reaction had gone almost to completion, R<sub>f</sub> (product) 0.85-0.90 (trace of starting material at R<sub>f</sub> 0.00).

The reaction mixture was chromatographed on a silica column and the benzoate eluted off with benzene. 90 mg. of product appeared in the eluate (94 per cent). After crystallisation three times from ethanol m.p. 146.5°C. was obtained;  $[\alpha]_D^{22}$ , -13.9. Found, C, 83.27; H, 10.59 per cent.  $C_{36}H_{54}O_2$  requires C, 83.34; H, 10.49 per cent.

2. 3.5 Dinitrobenzoate - The same procedure as used above was followed, but using 3.5 dinitrobenzoyl chloride. Thin layer chromatography (alumina plates) of the reaction mixture using 20 per cent ethyl acetate/petroleum spirit showed one spot, Rf 0.95 (original material Rf 0.22 - Table VIII). m.p. after three crystallisations from ethanol, 201-202°C.;  $[\alpha]_D^{23}$ , -10.8. Found, C, 71.09; H, 9.20 per cent.  $C_{36}H_{52}O_6N_2$  requires C, 70.90; H, 8.76 per cent.

3. Acetate - The same procedure as above was used, but employing acetyl chloride. Thin layer chromatography of the reaction mixture (alumina plates - 20 per cent ethyl acetate/petroleum spirit) showed the product, Rf 0.95, and a trace of original material. After two crystallisations from ethanol m.p. 120.5-121.5°C.;  $[\alpha]_D^{22}$ , -41.6. Found, C, 81.61; H, 11.34 per cent.  $C_{31}H_{52}O_2$  requires C, 81.58; H, 11.60 per cent. The infra-red absorption spectrum is shown in Fig. 8.

4. 3.5 Dinitrophenylurethan - 44 mg. isolated material was dissolved in 5 ml. dry toluene and

70 mg. 3.5 dinitrobenzazide (Section 2.42) was added. The reactants were heated for 2 hours under reflux.

The reaction mixture, after evaporation of the solvent, was chromatographed on an alumina column and the first yellow band (product) eluted off with 20 per cent ethyl acetate/petroleum spirit. Thin layer chromatography of the product on alumina plates gave Rf. 0.50 (20 per cent ethyl acetate/petroleum spirit).

After crystallisation from ethanol (three times) m.p. 159-159.5°C. Found, C, 69.16; H, 8.58 per cent.  $C_{36}H_{53}O_6N_3$  requires C, 69.20; H, 8.71 per cent.

Commercial 'β-sitosterol'

This was found to be highly impure - m.p. 118-120°C. Rough chromatography on a silica column indicated contamination by two ketonic substances (probably  $\Delta^4$  and  $\Delta^5$ -3-ones, from infra-red absorption bands) to the extent of some 15 per cent.

A sample of this crude commercial material was purified by chromatography and crystallisation from petroleum spirit (b.p. 40-60°C.), ethanol, and

finally petroleum spirit. m.p. 134-135.5°C.  
Infra-red and ultra-violet absorption spectra  
were identical with those of the isolated material  
(see Fig. 8);  $\lambda$  max. 204 m $\mu$  ( $E_{1\text{cm.}}^{1\%}$  53;  $\epsilon$  204, 2,168  
(Table XXI)).

Mixed melting point of isolated and  
commercial  $\beta$ -sitosterol

Isolated material	-	134.5-135°C.
Commercial material	-	134-135.5°C.
Mixed m.p.	-	135-135.5°C.

2.46 Fraction V

The ultra-violet absorption spectrum showed characteristic conjugated triene bands at  $\lambda$  max., 260, 271, 283  $\mu$  (Fig. 14), suggesting the presence of partially saponified material.

The material on which the infra-red absorption spectrum was obtained was unfortunately inadvertently contaminated with Fraction IV (' $\beta$ -sitosterol') but the following bands were present in the infra-red spectrum which did not appear in the sterol spectrum (Figs. 8 and 9);  $\nu$  max. 1730 (-C=O, ester), 1285, 1260, (CH-OH and -CH<sub>2</sub>-OH), 1212 (ester C-O), 1120 and 1072 (CH-OH and -CH<sub>2</sub>-OH).

The fraction was resaponified as follows:-

31 mg. (containing 8 mg. sterol) was saponified for one hour under nitrogen, with 14 ml. ethanolic potassium hydroxide (10 per cent KOH in 90 per cent EtOH). After cooling and the addition of iced water, the mixture was extracted with petroleum spirit (Extract I). The aqueous phase was acidified with dilute hydrochloric acid (cloudiness produced) and extracted with diethyl ether (Extract II). The

ultra-violet absorption spectra on these extracts showed, for Extract I, a shoulder at 269  $\mu$  ( $E_{1\text{cm.}}^{1\%} 31$ ), and, for Extract II, an absorption maximum at 269  $\mu$  ( $E_{1\text{cm.}}^{1\%} 85$ ).

Extract I was again saponified and no maximum was visible above the background absorption in the 269  $\mu$  region for Extract I (I) but shoulders at 260 and 269  $\mu$  were observed for the ether extract (Extract I (II)).

2.47 Fraction VI

This material was found to be labile in character. A colour change was observed shortly after isolation from a bright copper-green to a dull grey-green, together with a marked change in solubility (in both carbon disulphide and petroleum spirit (b.p. 40-60°C.)). The infra-red absorption spectrum of the freshly isolated material in chloroform showed low absorption maxima (due to the small quantity of material available) at 1727 (C=O), 1605 (C=C-), 1548, 1490, 1456 (CH<sub>2</sub>-), 1438 (C-CH<sub>3</sub>) cm.<sup>-1</sup>, below 1400 cm.<sup>-1</sup> the absorption maxima produced were identical with the absorption of the solvent blank. Absorption was noted in the 280-500 mμ range, giving λ max. 327 mμ, inflexion at 356 mμ in chloroform, and then only the maximum at 327 mμ in ethanol.

The quantity of material isolated was insufficient for further investigation.

## 2.48 Carotenoid Pigment

Most of the yellow-orange colour was eluted from the chromatographic column together with the sterol. Carotene determinations at 453  $\mu$  on the sterol fraction gave a negative result, but absorption in the 260-320  $\mu$  region was observed. It was thought that this absorption was possibly due to oxidised carotenoid pigment; this was substantiated by the detection of polar materials, in addition to a weakly polar component (Table XXIII) by partition chromatography of the isolated coloured material. The total unsaponifiable matter was therefore examined in the 450  $\mu$  region (in absolute ethanol) prior to chromatography, as was the original tung oil (in petroleum spirit (b.p. 40-60°C.)), before saponification. In the former case absorption maxima were observed at 430, 453, 480 (inflexion)  $\mu$ , and strong absorption was noted in the 320-360  $\mu$  region;  $E_{1\text{cm.}}^{1\%}(453) = 2.21$ .  $E_{1\text{cm.}}^{1\%}$  for  $\beta$ -carotene in n-hexane at 452  $\mu$  is quoted as 2650<sup>(33)</sup>, therefore the carotenoid pigment recorded was equivalent to

840  $\mu\text{g./g.}$  of the unsaponifiables as  $\beta$ -carotene ( 3.4  $\mu\text{g./g.}$  oil based on an unsaponifiable content of 0.41 per cent). In the latter case absorption maxima were observed at 406, 430, 453, 476 (inflexion)  $m\mu$  and strong absorption was again noted in the 320-360  $m\mu$  region  $E_{1\text{cm.}}^{1\%}(453) = 0.152$ . This is equivalent to a carotenoid pigment content (as  $\beta$ -carotene) of 5.8  $\mu\text{g./g.}$  oil ( 1,424  $\mu\text{g./g.}$  unsaponifiables).

Partition paper chromatography of the pigment, using the method of Kodicek and Ashby<sup>(23)</sup> (see Section 2.42) gave at least four spots of the following Rf values:-

Table XXIII:

Mobile Phase	1	2	3
Rf of component (1)	0.92	0.96	0.97
(2)	0.30	0.72	-
(3)	0.15	0.57	0.47
(4)	0.00	0.02	0.00

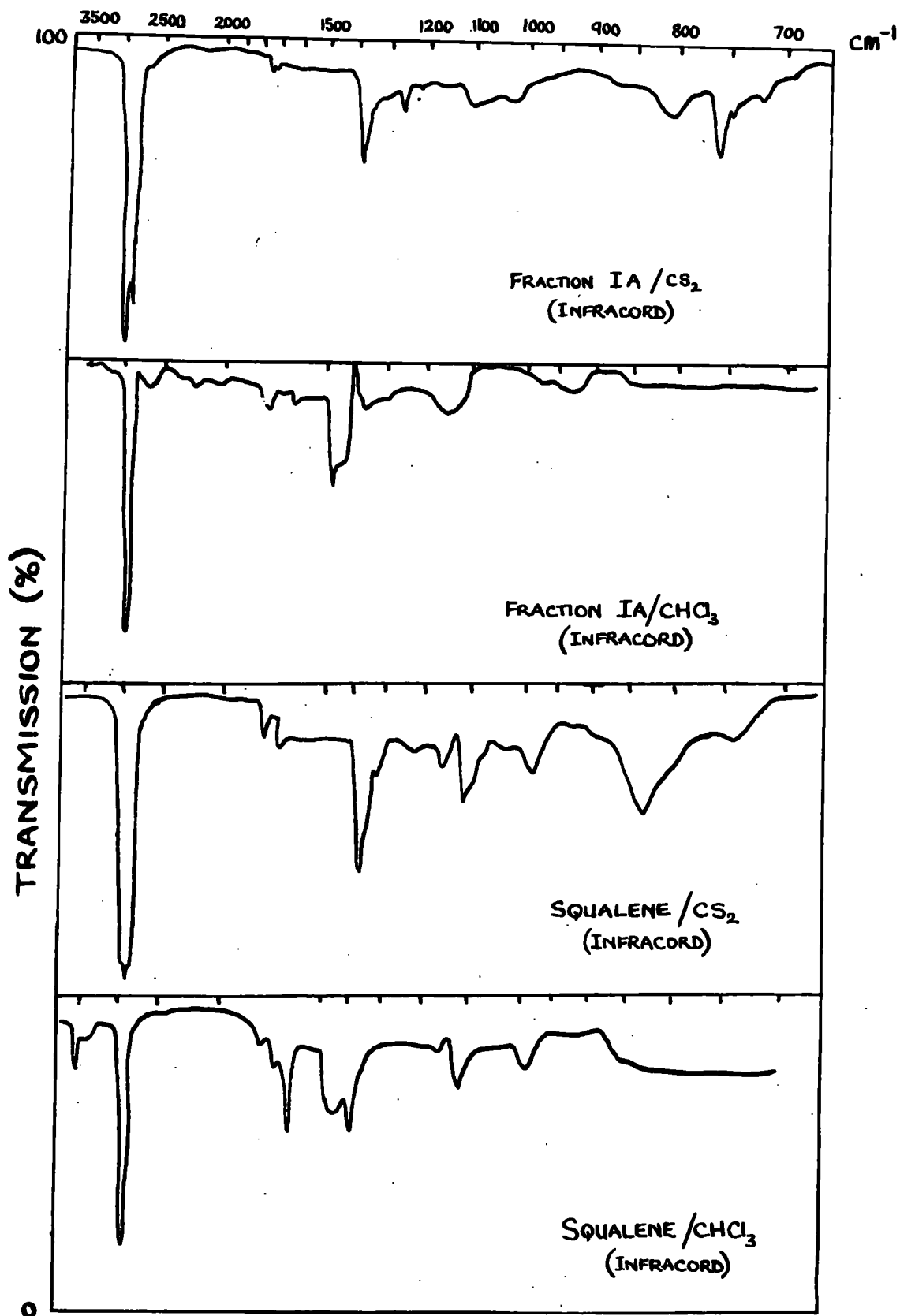

Fig. 3.

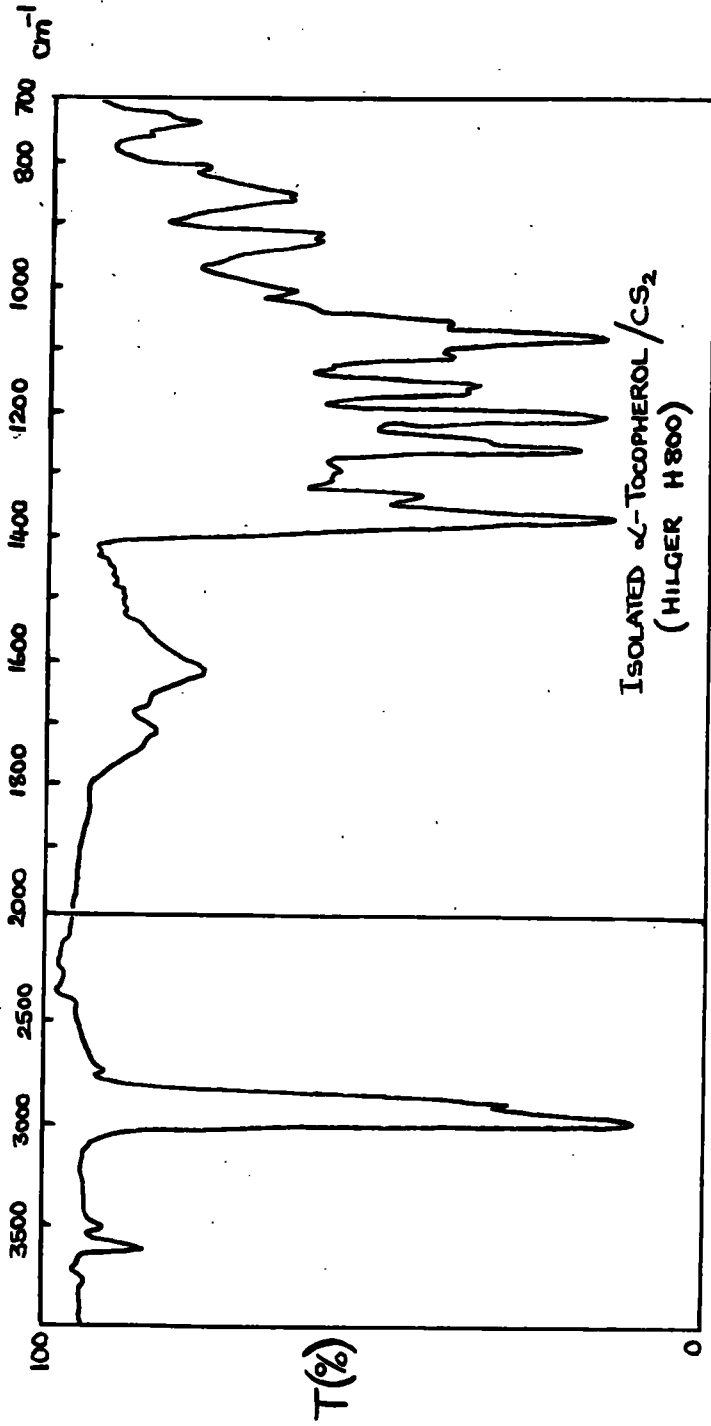

Fig. 4

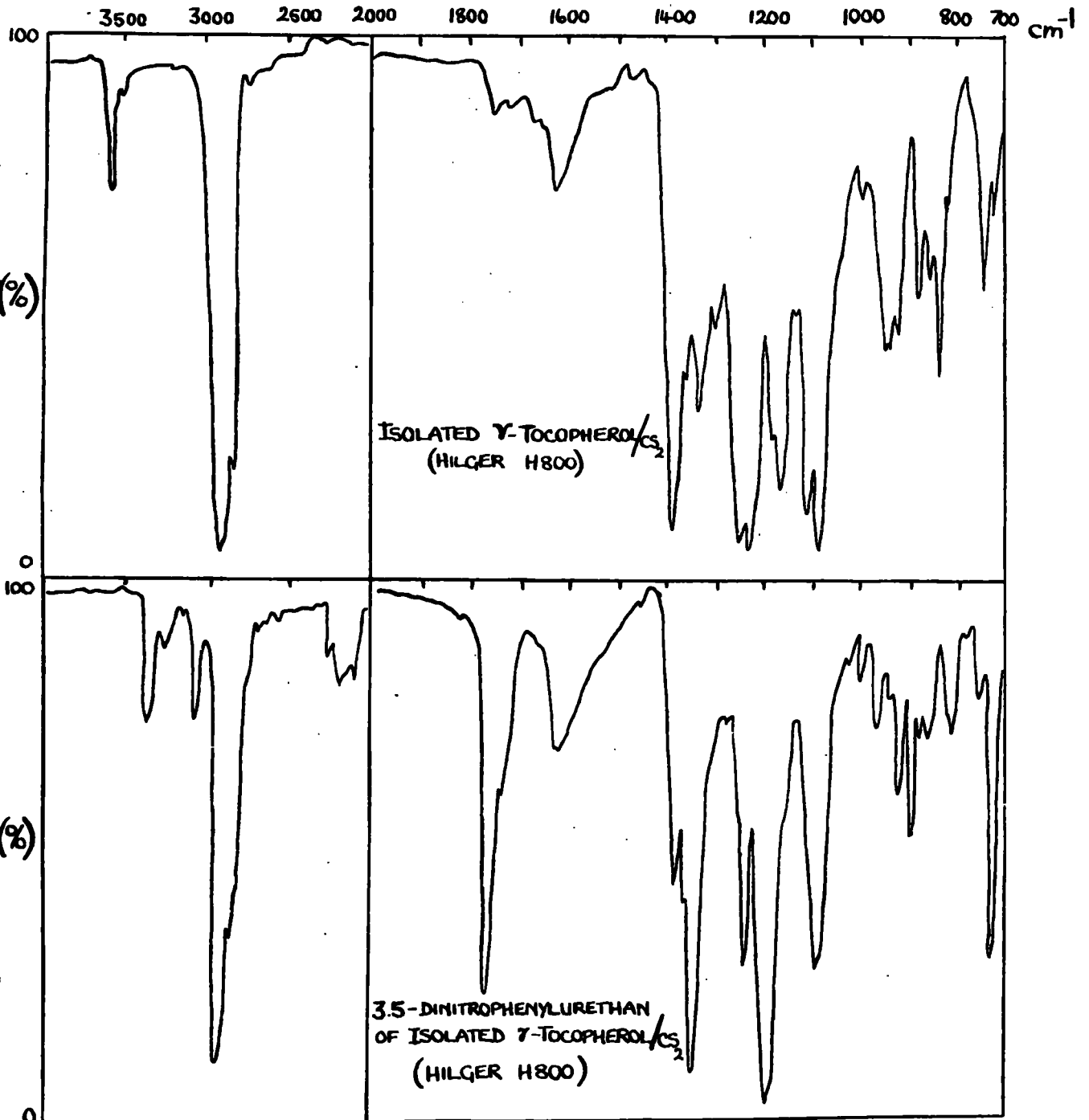

Fig. 5

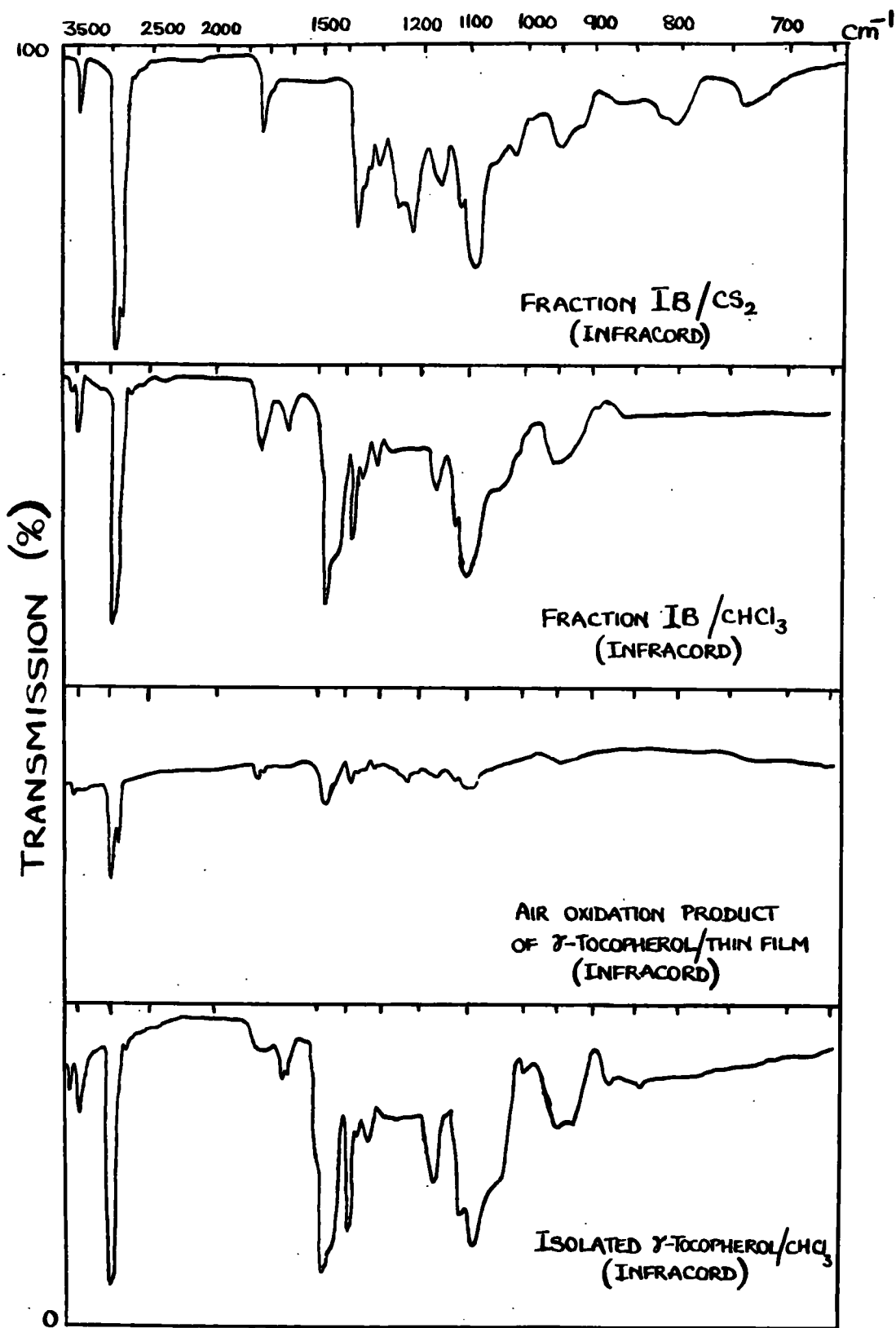

Fig. 6

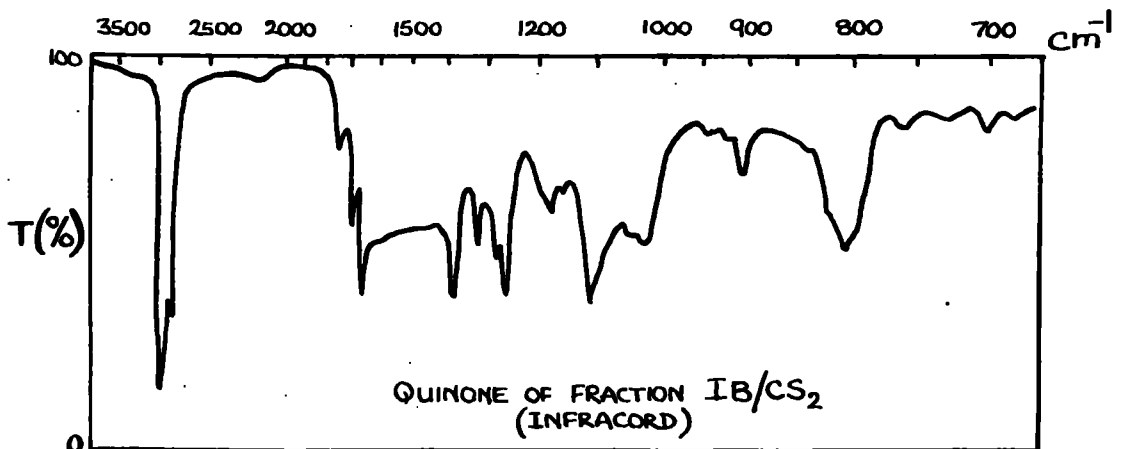
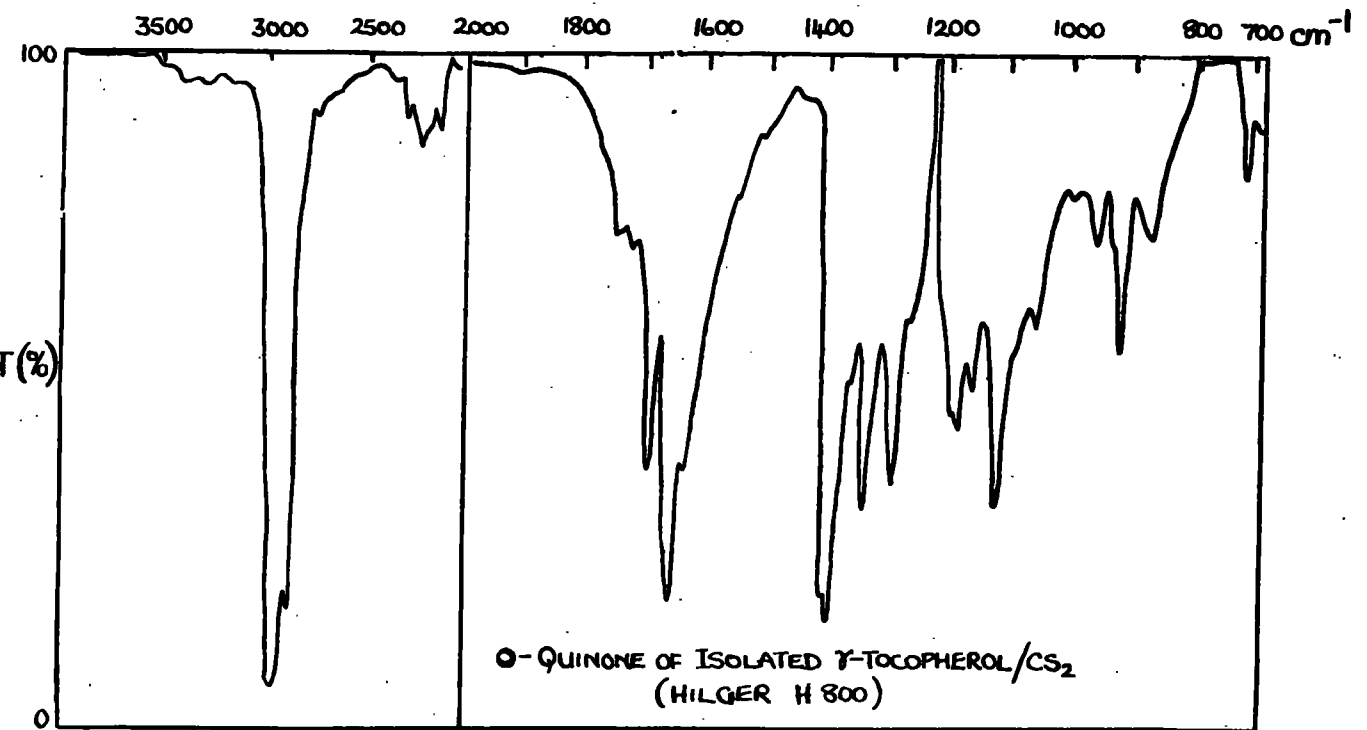

Fig. 7

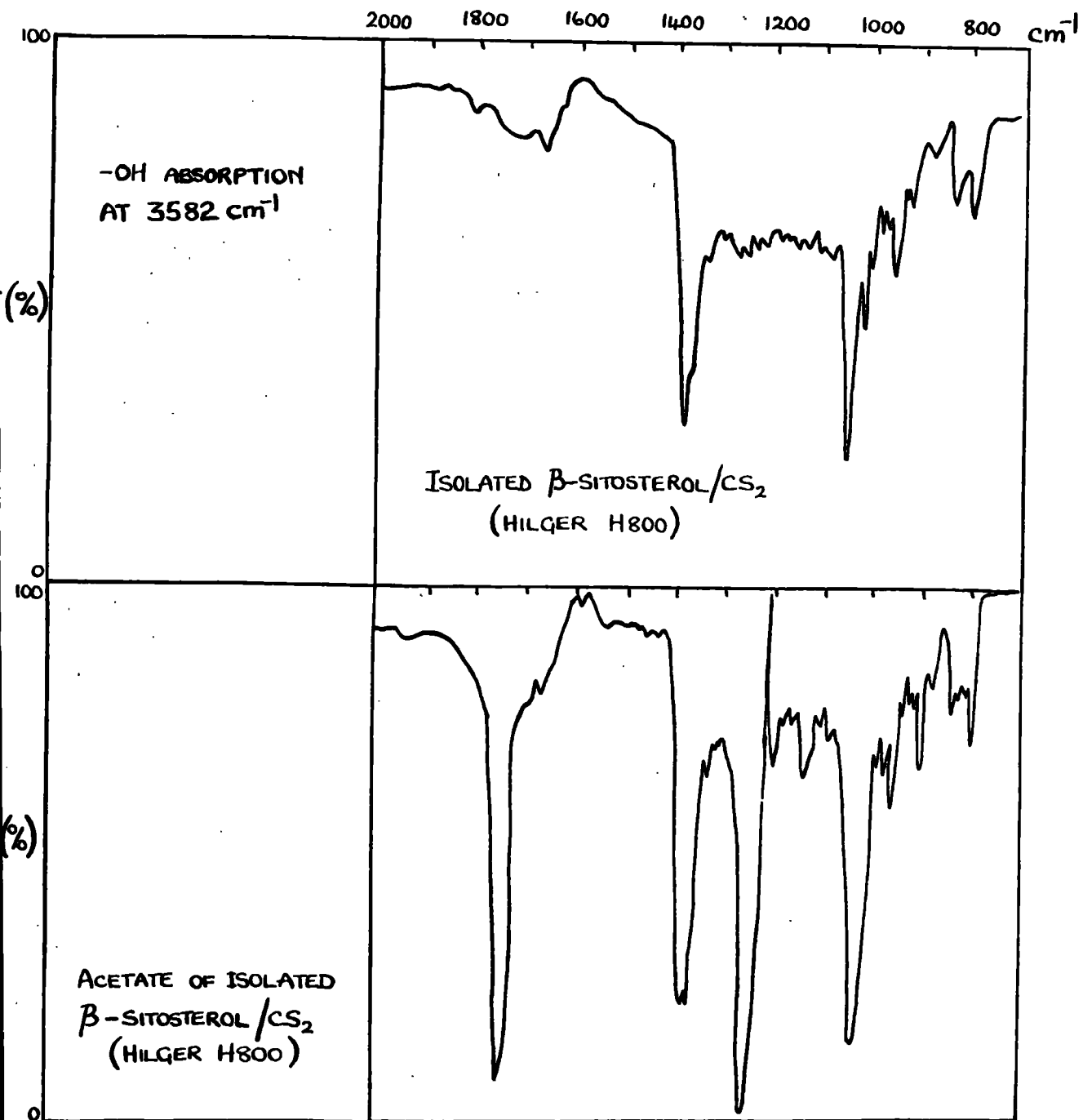

Fig. 8

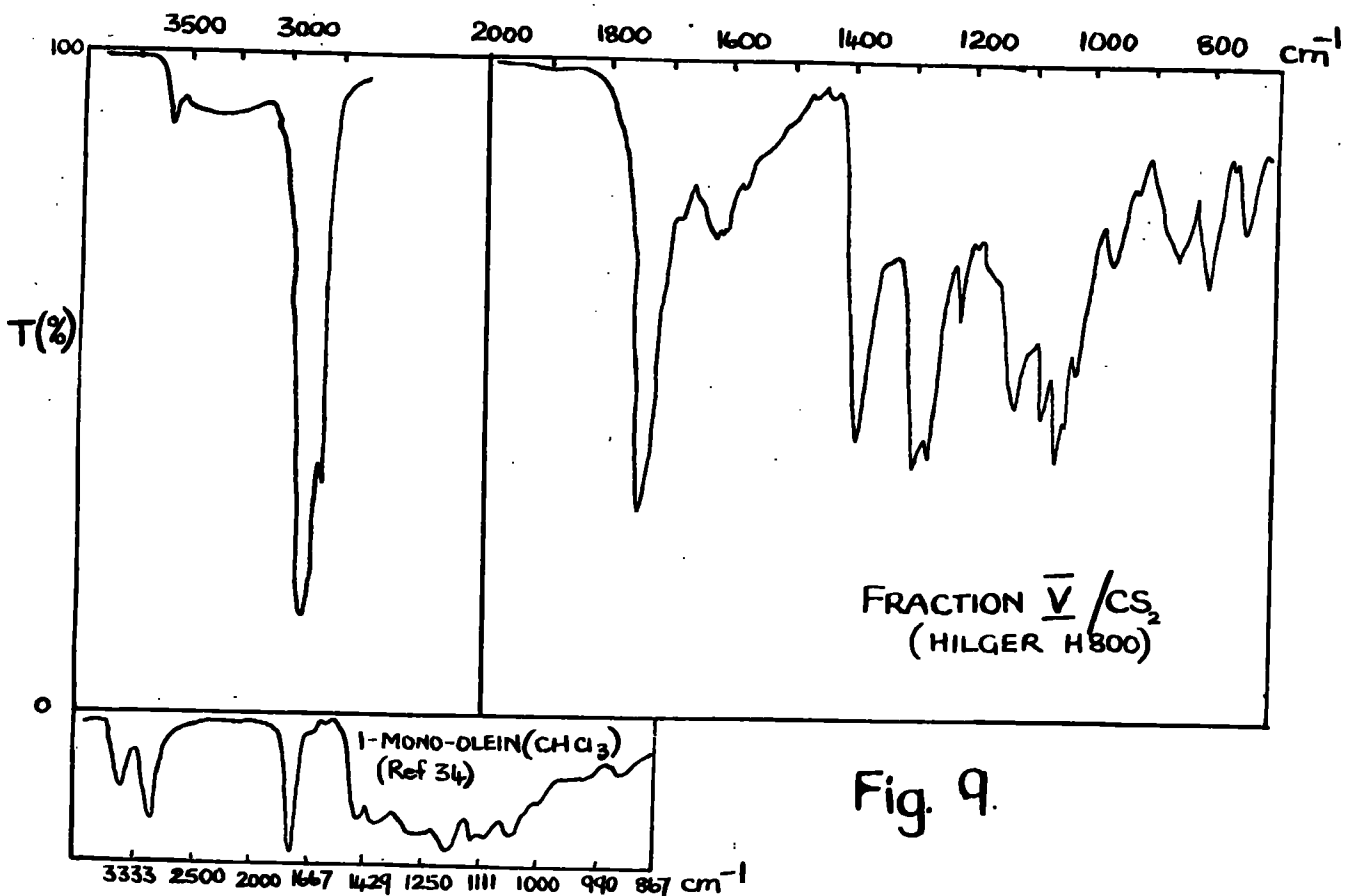
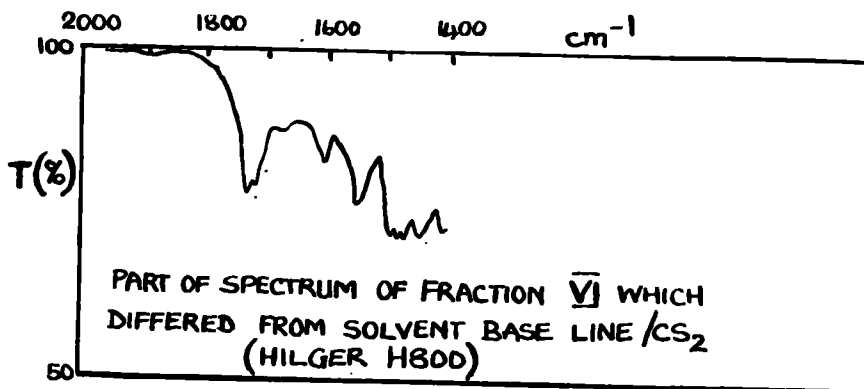

Fig. 9.

Fig. 10.



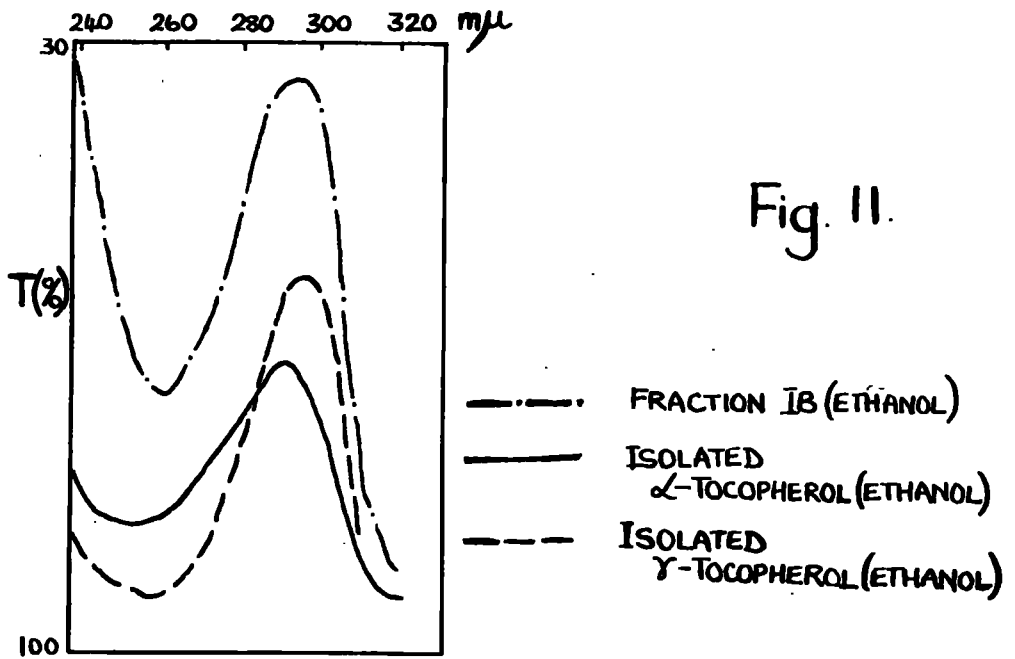

Fig. 11.

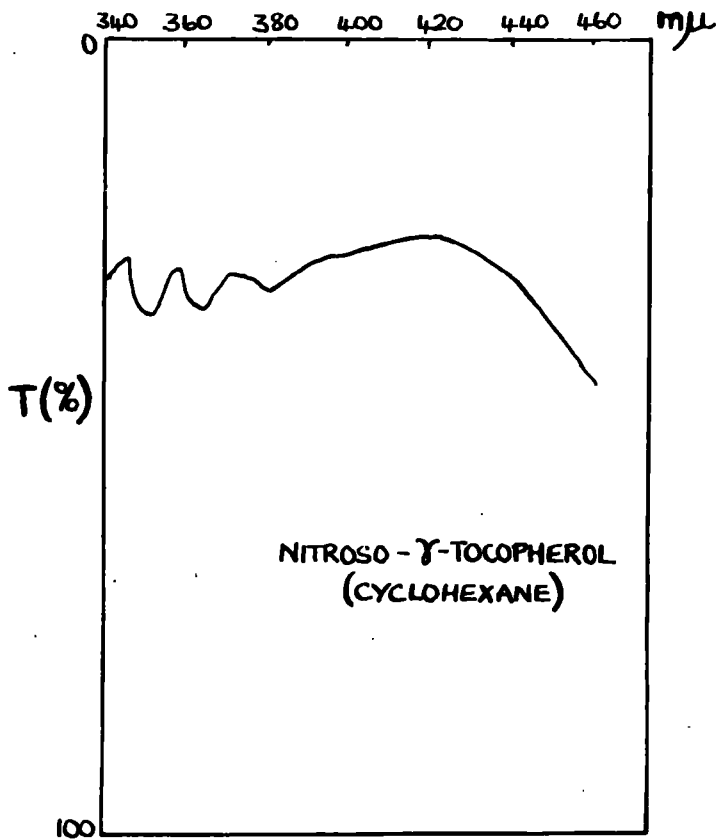

Fig. 12.

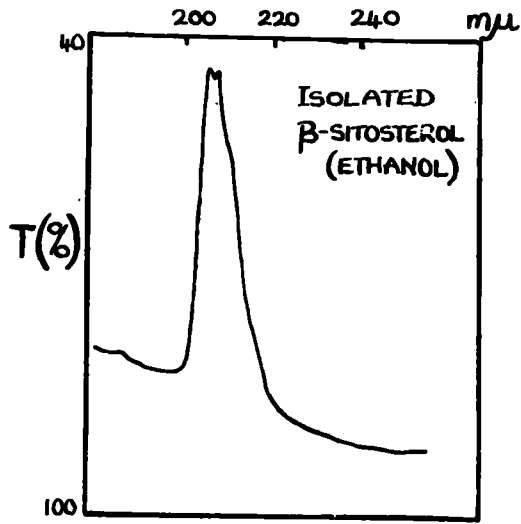

Fig. 13.

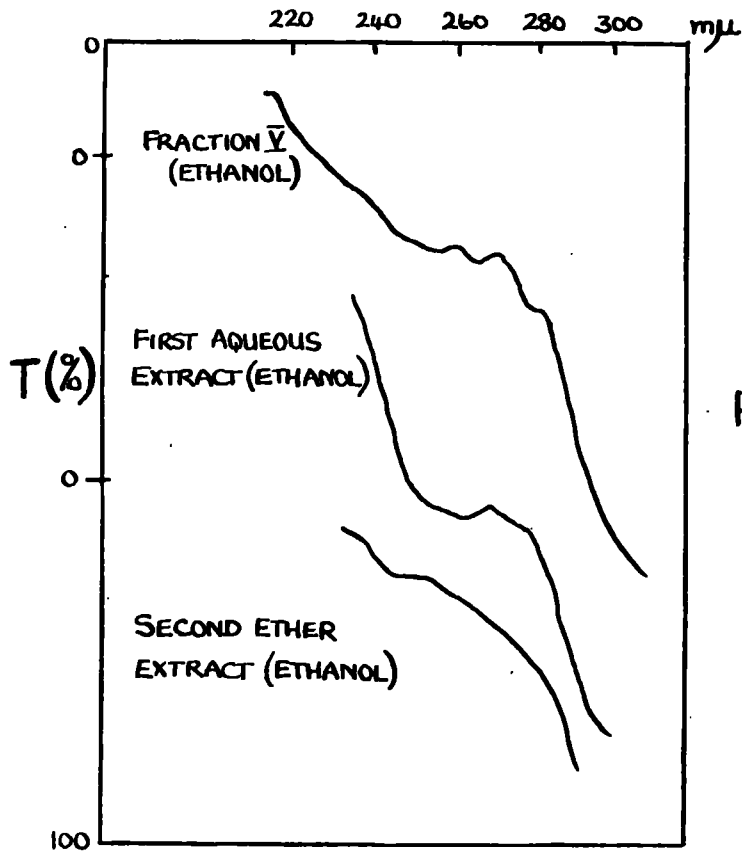

Fig. 14.

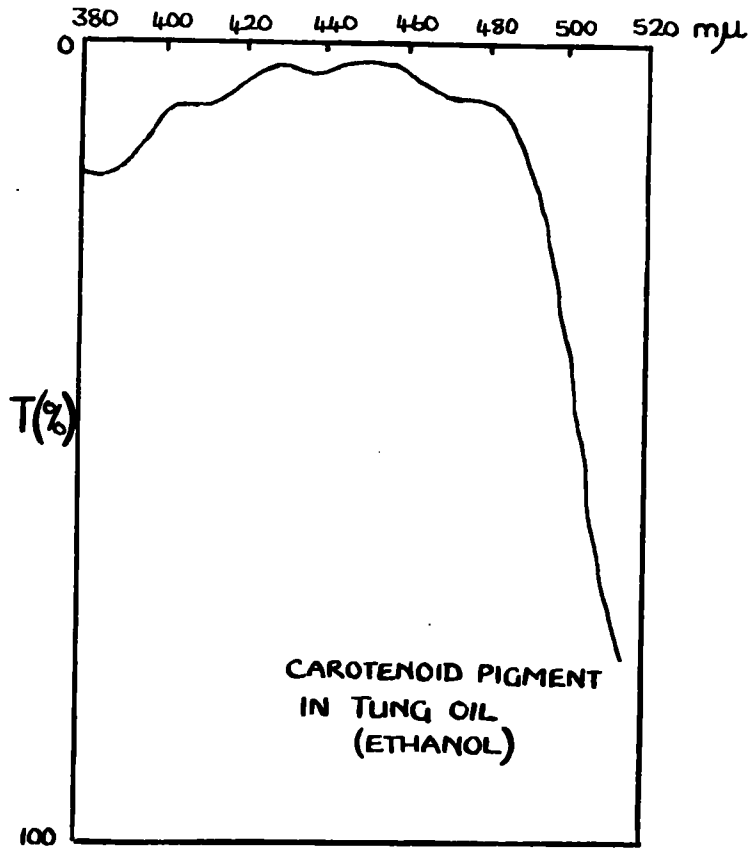

Fig. 15.

### 3. DISCUSSION

The saponification of tung oil, the chromatographic separation of the unsaponifiable material and the identification of the isolated components will be discussed separately.

#### 3.1 Saponification

##### 3.1.1 Prevention of oxidation during saponification

An atmosphere of nitrogen and the presence of pyrogallol were used in the saponification stage in order to prevent oxidation of any labile unsaponifiable materials. The nitrogen eliminated most of the oxygen from the reaction vessel and any traces remaining were removed by the pyrogallol. If, however, any radicals were formed by oxygen attack these, and any present in the original oil, would be prevented from further reaction by the chain breaking properties of the pyrogallol. The efficacy of polyphenols as radical chain breakers depends upon a fast reaction



rate and the stability of the intermediate radical  $RO\cdot$  (32).

The necessity of using pyrogallol is illustrated by the fact that when this compound was not present

during saponification, the total amount of tocopherols isolated from the unsaponifiables of tung oil was lower, and the quantity of tocopherol artefact (Fraction IB) correspondingly higher than when pyrogallol was used (Table XVI).

Other workers emphasise the desirability of using pyrogallol in the saponification of oils containing tocopherols. Kubin and Fink<sup>(15)</sup> suggest the use of either sodium ascorbate or pyrogallol; the Vitamin E Panel<sup>(22)</sup> specify the use of pyrogallol; and Tošić and Moore<sup>(12)</sup> quote figures for the recovery of added  $\alpha$ -tocopherol after saponification in the presence and absence of pyrogallol (Table XXIV).

Table XXIV: Recovery of synthetic  $\alpha$ -tocopherol after saponification in the presence and absence of pyrogallol.

	Recovery (%)	
	Absence	Présence
$\alpha$ -tocopherol - absence of oil	58.7	99.2
	57.2	98.2
from the acetate - absence of oil	37.7	98.8
	58.4	99.4
	52.8	99.2
	85.2	98.2
from the acetate in presence of groundnut oil	89.3	98.2
	87.4	98.6
	83.2	97.5
	86.0	98.6

### 3.12 Estimation of the efficiency of saponification

In order to obtain the efficiency of saponification of the isolated unsaponifiable material (Table XVI), the elaeostearate content was calculated from absorption data (Section 2.21) and multiplied by a factor of 1.43 to correct for the 30 per cent fatty acids which were not estimated by the above procedure.

### 3.2 Chromatography

One of the main advantages in using thin layer chromatography to separate a mixture of compounds is that the adsorbent and solvent mixtures used as eluents to effect such a separation may be transferred to a column scale with the certain knowledge that similar separations of components can be achieved. A further point in favour of this type of chromatography is the extreme rapidity with which results can be obtained; it takes 20-30 minutes to run a thin layer chromatogram, and this is extremely advantageous both when developing a separatory method, prior to running a chromatographic column, and when ascertaining the purity of fractions obtained from a column. Also, a wide range of methods of detecting spots may be used

and aggressive reagents and high temperatures employed, e.g. concentrated sulphuric acid was found to give very sensitive detection (down to the order of 1  $\mu$ g) for most compounds encountered; this reagent could not be used in conjunction with paper chromatograms.

Thin layer chromatography was successfully used in the terpenoid field in the early 1950's<sup>(35)</sup>; during the past few years it has found favour in many other fields<sup>(20)</sup>, e.g. steroids, pyrethrins, vitamins<sup>(19, 36)</sup>, 2,4 dinitrophenylhydrazones<sup>(37)</sup>, etc.<sup>(38)</sup>, but workers seem to have confined themselves almost solely to the use of layers of silicic acid.

The method of preparation of the thin layers described in Sections 2.31, 2.32, was found to give satisfactory results. Thinner layers may be satisfactorily obtained by varying the diameter of the glass guide rods and/or the thickness of the glass plates. Equipment has recently been marketed by C. Desaga of Heidelberg and by Carl Roth of Karlsruhe, which is designed to give layers of thickness of

about 275  $\mu$ . The availability of these pieces of apparatus is probably responsible for the increasing popularity of this method of separation.

Separation of the component materials of a mixture by adsorption chromatography is dependent upon the differing polarities of the component molecules, the more polar entities being more strongly adsorbed on to the solid phase and therefore travelling the least distance up (in the case of thin layers) the chromatogram.

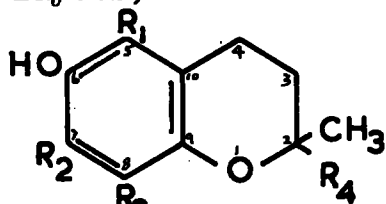

- X -  $R_1 = R_2 = R_3 = -CH_3$ ;  $R_4 = \left[ -CH_2 \cdot CH_2 \cdot CH_2 \cdot \overset{\overset{CH_3}{|}}{CH} - \right]_3 \cdot CH_3$
- XI -  $R_1 = R_3 = -CH_3$ ;  $R_2 = -H$ ;  $R_4 =$  as above
- XII -  $R_1 = -H$ ;  $R_2 = R_3 = -CH_3$ ;  $R_4 =$  as above
- XIII -  $R_1 = R_2 = -H$ ;  $R_3 = -CH_3$ ;  $R_4 =$  as above
- XIV -  $R_1 = R_3 = -CH_3$ ;  $R_2 = -H$ ;  $R_4 = \left[ -CH_2 \cdot CH_2 \cdot \overset{\overset{CH_3}{|}}{CH} = \overset{\overset{CH_3}{|}}{C} - \right]_3 \cdot CH_3$
- XV \* -  $R_1 = R_2 = -CH_3$ ;  $R_3 = -H$ ;  $R_4 =$  as for X
- XVI -  $R_1 = R_3 = -H$ ;  $R_2 = -CH_3$ ;  $R_4 =$  as for X

\* This proposed structure is now in serious doubt<sup>(22)</sup>

It has been stated<sup>(39)</sup> that the reason for the separation of the tocopherols into three groups ( $\alpha$ (X),  $\beta$ (XV);  $\beta$ (XI),  $\gamma$ (XII),  $\epsilon$  (XIV),  $\eta$  (XVI);  $\delta$ (XIII)) by adsorption chromatography is due to the ring methyl groups sterically hindering the approach of the phenolic -OH group to the adsorbent molecular surface. This is possible, but it seems likely that any such effect would be slight as 'Catalin' molecular models show little steric hindrance. Another factor which probably plays no small part in the separation of the tocopherols into these three groups, and which would be reinforced by any small steric effects present, is the change in polarity of the phenolic -OH group with aromatic ring methyl substitution. Separation probably depends largely upon the relative polarity of the phenolic -OH groups, as these are the most polar parts of the molecules. The polarity of the -OH group will change slightly with the number and position of the methyl groups attached to the aromatic ring. This is due to an inductive effect reinforced by a strong hyperconjugation resulting from overlap of the methyl C-H  $\sigma$

with the ring  $\pi$  orbitals. Thus methyl groups in the 5 and/or 7 position would tend to produce less polarity in the -OH group than would the 8 methyl group. Tocopherols containing both 5 and 7 methyl substituents would be expected to be chromatographically less strongly adsorbed than those containing 5 or 7 methyl groups which in turn would be expected to be less polar than 8 methyl substituted molecules. In fact,  $\alpha$ - and  $\beta$ -tocopherols chromatograph at the fastest rate followed by  $\beta$ ,  $\gamma$ ,  $\epsilon$  and  $\eta$  (all with 5 or 7 methyl groups);  $\delta$ -tocopherol being the most polar member of the series (no 5 or 7 substituents) travels the least distance.

After this work on the thin layer chromatography of  $\alpha$ - and  $\gamma$ -tocopherols had been completed, A. Seher<sup>(19)</sup> published a paper entitled 'Analysis of Tocopherol Mixtures by Thin Layer Chromatography'. The  $R_f$  values for  $\alpha$ - and  $\gamma$ -tocopherols (chromatographed on thin layers of silicic acid, using chloroform and benzene eluents) from Seher's work, are compared in Table V with those obtained in this work for the  $\alpha$ - and  $\gamma$ -tocopherols isolated from tung oil. As

mentioned previously (Page 15), the thin layers of silica used in this work were slightly more active than those used by Seher (also than those referred to by Demole<sup>(20)</sup>).

Some notes on the non-use of aluminium oxide and charcoal columns

A cursory examination of the possibility of using alumina as adsorbent for the separation of the unsaponifiable material did not produce separation between  $\alpha$ - and  $\gamma$ -tocopherols, whereas silicic acid did give obvious separation; later, when pure  $\alpha$ - and  $\gamma$ -tocopherols were chromatographed on alumina plates a separation was achieved. This accounts for the fact that an 'elongated' tocopherol spot was obtained when the unsaponifiables were chromatographed on thin layers of alumina.

Also, as mentioned in Section 2.33 and illustrated in Table XII, tocopherols were found to undergo chemical change when separation was attempted using alumina columns (Grade 1), many artefacts of varying polarities being formed. This problem was not experienced to any significant extent when chromatographing

tocopherols on thin layers of alumina, as the contact time with the adsorbent was short.

Many instances of chemical change in the presence of alumina have been reported. For example, hydroxy methylene groups adjacent to aromatic rings may be converted to ketonic groupings in yields up to 92 per cent by passing air through a mixture of the compound and alumina at 120°C. for 48 hours<sup>(40)</sup>; An Aldol type condensation reaction between quinones (XVII) and ketones occurs in the presence of alumina at room temperature<sup>(41)</sup>

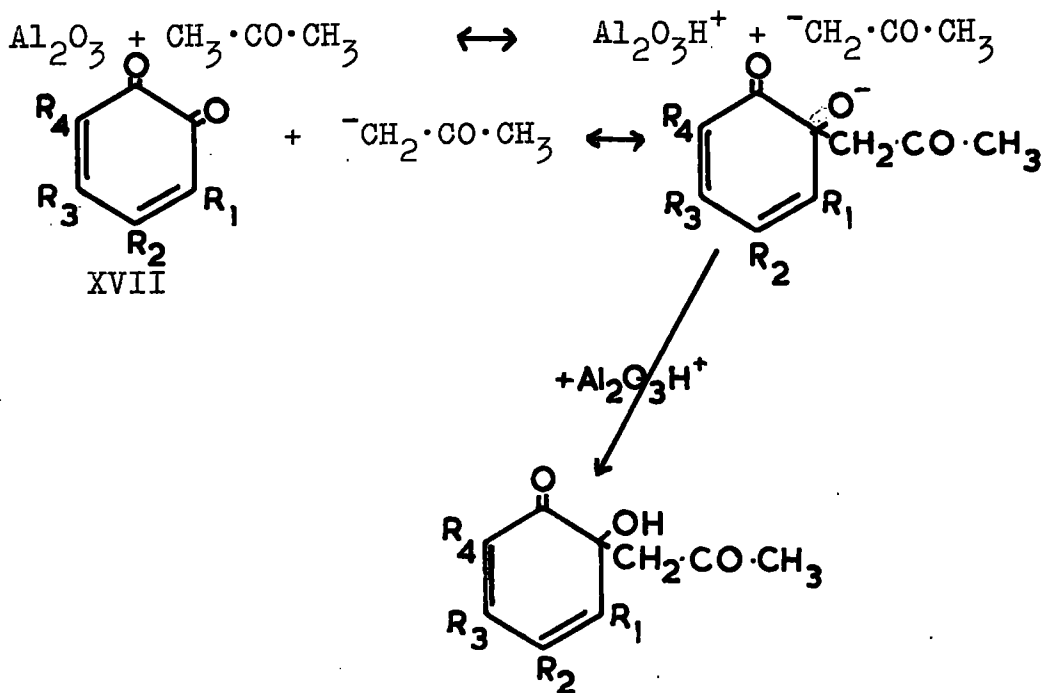

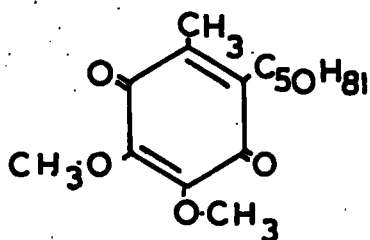

XVIII

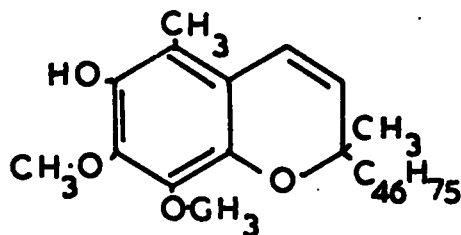

XIX

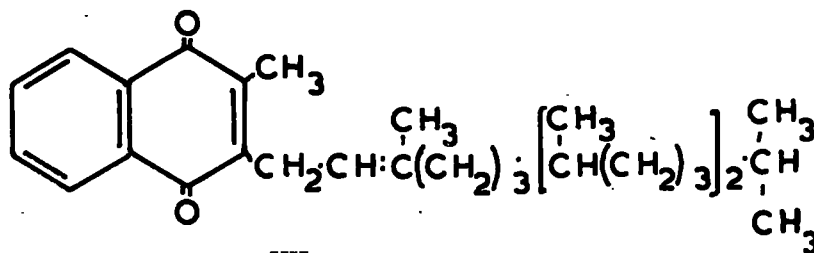

XX

and the partial conversion of ubiquinone (XVIII) to ubichromenol (XIX) by contact with grade 0 alumina at room temperature overnight and of vitamin K (XX) to an artefact by contact with acid washed grade 2 alumina, have recently been reported<sup>(42)</sup>.

During the course of this work on tung oil unsaponifiables, the inadvertent use of an alumina (Griffin & George Ltd. - chromatographic grade) column instead of silicic acid adsorbent (due to a labelling error on the part of the suppliers!) to purify a tocopherol isolate, resulted in the total loss of the tocopherol. Acetone was used in an attempt to

remove some of the more polar products and a quantity of white crystalline solid material was found in the eluate, together with traces of a volatile liquid which smelled strongly of mesityl oxide. Presumably condensation of the acetone had occurred in the presence of the alumina. The product was not investigated further.

The use of charcoal, as adsorbent, was not pursued due to the production of tocopherol artefacts on the column (see Section 2.344).

### 3.3 Identification of the Isolated Components

#### 3.31 Fraction IA (Possibly Squalene)

The manner in which this material chromatographed on silicic acid suggests a weakly polar molecule. The fact that the isolated material chromatographed in the same position, and gave a spot of similar colour (after detection) as a commercial sample of squalene on thin layers of silicic acid, suggests a molecule of similar polarity. The infra-red absorption spectra (Fig. 3) show ill-defined bands of low intensity due to the small quantity of material available. However, the presence of methyl groups and unsaturation and the absence of other group absorption bands, suggests a molecule of the squalene (VIII) type (especially as squalene has been reported as being present in the unsaponifiables of tung oil<sup>(13)</sup> (Section 1) and that the view is held that squalene is an intermediate in the biosynthesis of sterols.

The major component of this isolated fraction may be squalene or a similar unsaturated hydrocarbon.

The possible occurrence of squalene to the extent

of approximately 0.8 per cent of the unsaponifiable matter of tung oil reported here (when Dickhart<sup>(13)</sup> reports about 6 per cent for the tung oil he examined) is not surprising when the method of estimation of squalene content used by Dickhart (the method of J. Fitelson<sup>(43)</sup>) is examined. The least polar material from the unsaponifiabiles of tung oil was eluted from an alumina chromatographic column with petroleum spirit, and the measured unsaturation of this material assumed to be due to the sole presence of squalene. The homogeneity of the eluted material was not examined and it is likely that squalene, if present, was accompanied by other unsaturated material.

Dickhart<sup>(13)</sup> has reported the presence of squalene in palm, rapeseed and tung oils to the extent of 15-29 mg./100 g. oil (approximately 3-6 per cent of the unsaponifiabiles).

3.32 Fraction II ( $\alpha$ -tocopherol)

The infra-red and ultra-violet absorption spectra suggest the possibility that this material is a tocopherol and these spectra are identical with those of a commercial sample of  $\alpha$ -tocopherol (Figs. 4 and 11). The extinction coefficient of the isolated material agrees with previously reported values (Table XXV).

Table XXV: Position of absorption maxima and minima and  $E_{1\text{cm.}}^{1\%}$  for  $\alpha$ -tocopherol in absolute ethanol.

	$\lambda$ max., $\mu$	$E_{1\text{cm.}}^{1\%}$	$\lambda$ min., $\mu$
Isolated $\alpha$ -tocopherol	292	72	260
Commercial sample	292	73	259
Literature values Ref. (44)	292	74.5	-
Ref. (45)	292	71	-
Ref. (46)	292	75.8	256

When paper chromatographed by the methods given in Section 2.42, the material appeared in the  $\alpha$ -tocopherol position (Table XVII).

Failure to give an o-quinone and a nitroso compound by the methods stated agree with published observations on the properties of  $\alpha$ -tocopherol<sup>(25)</sup>.

The 3.5 dinitrophenylurethan derivative (XXI)

analysed for the molecular formula of this derivative of  $\alpha$ -tocopherol had a melting point in agreement with the reported value<sup>(21)</sup> of 145-147°C. for this compound.

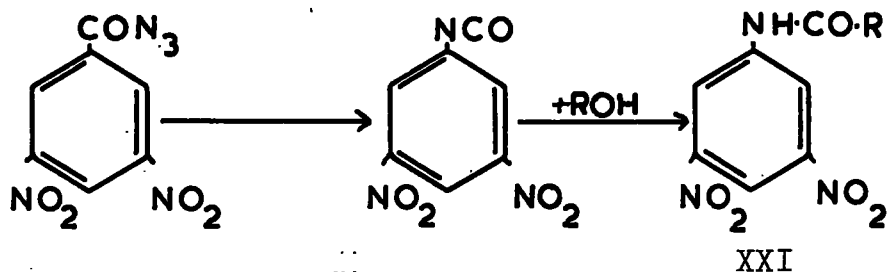

No melting point depression was observed when this derivative was mixed with the 3,5 dinitrophenylurethan of commercial  $\alpha$ -tocopherol and it is concluded that the isolated material of Fraction II is  $\alpha$ -tocopherol.

The low results obtained in the estimation of the purity of the isolated material by the method recommended by the Vitamin E Panel<sup>(22)</sup> deserve some comment. The results ranged from 71-105 per cent and this range is within that which is considered acceptable for this method by the Panel (see Table XXVI).

Table XXVI: Collaborative recovery tests of tocopherols added to an oil<sup>(22)</sup>

Laboratory	% Recovery of		
	$\alpha$	$\gamma$	$\delta$
B	106	118	100
D	88 105	95 117	79 92
F	97 99 93	98 106 94	94 96 95
G	70	108	57
H	105 80	76 87	39 56

It should be noted that it is essential to carry out the second stage of this estimation (i.e. the addition of the ferric chloride solution) in artificial light of the lowest intensity possible and to transfer the spectrophotometer cells to the instrument in the dark. The reason for this is that the determination depends upon the colour produced by chelation of ferrous ion (XXII) (formed by reduction of ferric ion by tocopherol). The presence of stray light will also effect the change  $Fe^{3+} \rightarrow Fe^{2+}$  to a very significant extent in the case of sample and

blank (though not to the same degree). It is probably this effect which is responsible for the wide range of results obtained.

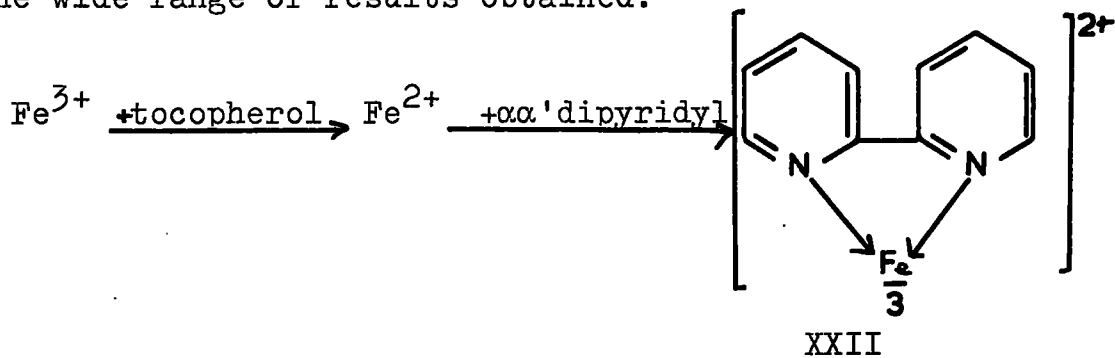

3.33 Fraction III ( $\gamma$ -tocopherol)

The infra-red and ultra-violet absorption spectra of this fraction were identical with those of a commercial sample of  $\gamma$ -tocopherol and the extinction coefficients obtained at  $\lambda$  max. were found to agree with those previously reported (Table XXVII).

Table XXVII: Position of absorption maxima and minima and  $E_{1\text{cm}}^{1\%}$  for  $\beta$ - and  $\gamma$ -tocopherols in absolute ethanol.

	$\lambda$ max., $\mu$	$E_{1\text{cm}}^{1\%}$	$\lambda$ min., $\mu$
<u><math>\gamma</math>-tocopherol -</u>			
Isolated material	297	96	260
Commercial sample	296	93	260
Literature values			
Ref. (47)	298	92.8, 90	-
Ref. (45)	298	93.2	-
Ref. (46)	298	91.4	257
<u><math>\beta</math>-tocopherol -</u>			
Literature values			
Ref. (45)	297	87.6	-
	295	87	-
	295.8	86	-
Ref. (46)	296	89.4	257.5

When paper chromatographed by the methods given in Section 2.43, the material appeared in the  $\beta/\gamma$  position (Table XVIII).





Table XXVIII: Absorption maxima of the o-quinones of  $\beta$ - and  $\gamma$ -tocopherols.

		$\lambda_{\text{max.}}$ m $\mu$
Isolated material	(1 mg. scale)	480
	(45 mg. scale)	466
Literature values <sup>(25)</sup>		
$\left. \begin{array}{l} (\beta\text{-tocopherol}) \\ (\gamma\text{-tocopherol}) \end{array} \right\}$	(1 mg. scale)	530
		480

The nitroso compound (XXIV) gave an absorption maximum which agreed with that reported for  $\gamma$ -tocopherol<sup>(25)</sup> (Table XXIX) and when paper chromatographed in two dimensions as described by Marcinkiewicz and Green<sup>(27)</sup>, a single spot appeared in the  $\gamma$ -tocopherol position (Table XIX) showing that the fraction was uncontaminated by  $\beta$ - or other tocopherols.

Table XXIX: Nitroso derivatives of  $\beta$ - and  $\gamma$ -tocopherols.

	$\lambda_{\text{min.}}$ m $\mu$	$\lambda_{\text{max.}}$ m $\mu$	$E_{1\text{cm.}}^{1\%}$ (max.)
Isolated $\gamma$ -tocopherol	353	420	59
Literature values <sup>(25)</sup>			
$\left. \begin{array}{l} (\beta\text{-tocopherol}) \\ (\gamma\text{-tocopherol}) \end{array} \right\}$	(300)	410	43.3
	(308)	416	59.4

$\beta$ -tocopherol does not condense with p-nitrobenzenediazonium chloride in the pH range 4.5-11<sup>(48)</sup>. The isolated material did condense with this reactant and the resulting azotocopherol (XXV) gave absorption maxima in agreement with those reported for the  $\gamma$  derivative (Table XXX).

Table XXX: Absorption maxima of p-nitrobenzene-azotocopherols formed at pH 6-6.5

	Quantity of material (mg.)	$\lambda$ max.	$\lambda$ min.	$E_{1cm.}^{1\%}$ (532)	$\epsilon$ (532)
Isolated $\gamma$ -tocopherol	0.65	386,532	459	76	3,163
Literature values <sup>(48)</sup>					
( $\beta$ -tocopherol)	(0.2-0.5	no absorption		-	-
( $\gamma$ -tocopherol)	(0.2-0.5	380,530	-	-	-

The ceric sulphate colour test<sup>(19)</sup> provided additional confirmation that the isolated material was  $\gamma$ -tocopherol rather than the  $\beta$ -compound.

The 3.5 dinitrophenylurethan gave a melting point of 156-157.5°C., which is not in agreement with the previously reported value for the  $\gamma$  derivative of

143-145°C.<sup>(21)</sup>. However, as no depression was observed when mixed with the derivative of a commercial sample of  $\gamma$ -tocopherol, it is assumed that the figure recorded by Smith and Sprung<sup>(21)</sup> is incorrect, and that this isolated fraction is, in fact, composed of  $\gamma$ -tocopherol. The melting point of 94-96°C. for the 3.5 dinitrobenzoate of  $\gamma$ -tocopherol appears not to have been recorded previously.

The tocopherols occur to some extent in most natural oils but their abundance varies considerably, and there appears to be no pattern to the occurrence of the individual members of the group in various environments (Table XXXI).  $\alpha$ - and  $\gamma$ -tocopherols appear to be those found most frequently in nature,  $\alpha$ -tocopherol having the highest biological (Vitamin E) activity.

Table XXXI: Tocopherol content of some vegetable oils (mg./100 g. oil)<sup>(49)</sup>

	Total	$\alpha$	$\beta$	$\gamma$	$\delta$
Cottonseed (crude)	110	76		34	
Palm	56	30		$\gamma$ & $\delta$	26
Groundnut	34	13		14	7
Soybean	99	21		78	
Wheat Germ (Merit)	268	161	107		
Tung (this work)	185	37		148	

In unsaturated oils the tocopherols play the important role of antioxidants, being preferentially oxidised themselves (to give oxidation products such as the artefact found in tung oil which is discussed in Section 3.34); their efficiency as oxidation inhibitors varies with the substrate, e.g. in lard fatty acid<sup>(50)</sup> methyl esters (predominant unsaturateds - oleate) at 90°C. there is a definite trend in antioxidant efficiency in the direction monomethyl > dimethyl > trimethyl, chromanol, but in poly-unsaturated substrates the reverse is true and antioxidant efficiency increases with nuclear methylation.

3.34 Fraction IB (Artefact of  $\gamma$ -tocopherol)

As mentioned in Section 2.44, the infra-red and ultra-violet absorption spectra of this material were found to resemble those of  $\gamma$ -tocopherol in certain respects, and the absorption band at  $1732 \text{ cm.}^{-1}$  suggests possibly a tocopherol oxidation product. The material was shown not to be a tocopherol by two dimensional paper chromatography<sup>(22)</sup>.

Further evidence supporting the view that this material is an oxidation product of  $\gamma$ -tocopherol was obtained when nitric acid oxidation produced a quinone which gave an identical infra-red absorption spectrum to that of the o-quinone of  $\gamma$ -tocopherol (Fig. 7); also, air oxidation of  $\gamma$ -tocopherol gave 2 mg. of material which produced a spot, by thin layer chromatography, of the same Rf and of the same colour (after sulphuric acid detection) as fraction IB. The infra-red absorption spectrum of this 2 mg. of material gave low absorption bands, due to the small quantity available, but these are identical with the bands given by fraction IB (Fig. 6).

Oxidation products of  $\gamma$ -tocopherol have received little attention to date, the o-quinone being the only one reported. In contrast, many such products of  $\alpha$ -tocopherol have been reported, viz:-  $\alpha$ -tocopheroxide<sup>(51,52)</sup> (XXVI),  $\alpha$ -tocopherylquinone (XXVII),  $\alpha$ -tocopheryl-o-quinone (XXVIII),  $\alpha$ -tocopurple<sup>(53)</sup> (XXIX), and various other unidentified oxidation products (e.g. the blue-grey oil of Frampton et al<sup>(54)</sup> and the unidentified materials produced by permanganate oxidation by Issidorides<sup>(55)</sup>).

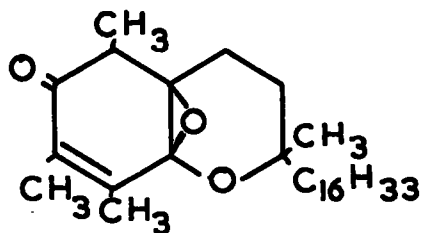

XXVI (a)

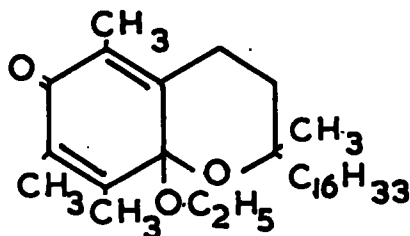

XXVI (c)

XXVI (b) - oxo group in 8, 9 position

(a) and (b) - first suggested structure of  $\alpha$ -tocopheroxide<sup>(51)</sup>.

(c) - most recent structure<sup>(52)</sup>.

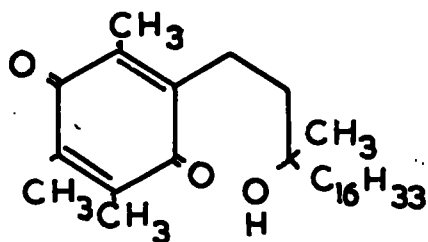

XXVII

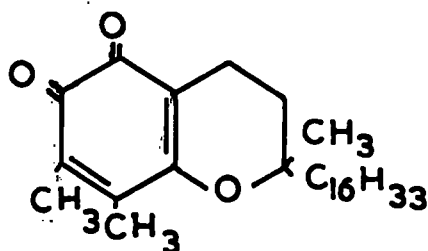

XXVIII

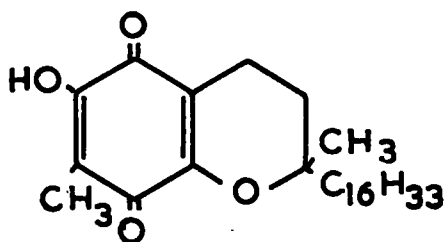

XXIX

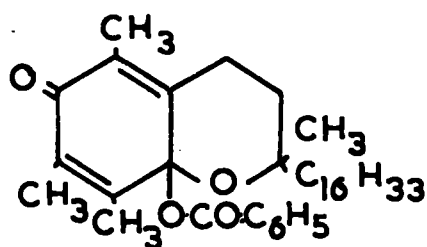

XXX

(56)  
 It has been reported that the main oxidation product of  $\alpha$ -tocopherol in autoxidizing fat is  $\alpha$ -tocopherylquinone together with a small quantity of an unknown structure with infra-red absorption bands at  $\nu_{\text{max.}}$ , 1736, 1685, 1370, 1260, 1090, 1015  $\text{cm.}^{-1}$  and no -OH peaks. Reaction of  $\alpha$ - and  $\gamma$ -tocopherols with benzoyl peroxide<sup>(57)</sup> give  $\alpha$ -tocopherylquinone and  $\gamma$ -tocopheryl-o-quinone respectively, and it has been suggested that a structure of the type (XXX) is an intermediate in the case of the  $\alpha$ -tocopherol reaction.

The isolated material (Fraction IB) is prevented from being the  $\gamma$ -analogue of any of the above compounds on infra-red and ultra-violet absorption grounds. The absorption spectra (Figs. 6 and 11) show the heterocyclic ring to be intact and ketonic and hydroxyl groups to be present. In view of the fact that chromatography on both silicic acid and on vaseline impregnated paper (Table XXXII) indicated a molecule of low polarity it is surprising that a hydroxyl group is present; it is possible, therefore, that steric effects prevent the hydroxyl group from coming into close contact with other molecular surfaces.

Table XXXII: Chromatography of  $\alpha$ -tocopherol, some of its oxidation products and Fraction IB, on vaseline impregnated paper.

	Rf(77% EtOH)	Rf(100% EtOH)
Fraction IB	0.00	0.56
$\alpha$ -tocopherol	0.48	1.00
Literature values <sup>(24)</sup>		
$\alpha$ -tocopherol	0.55	-
$\alpha$ -tocopheroxide	0.08 - 0.90	-
$\alpha$ -tocopherylquinone	0.92	-
$\alpha$ -tocopheryl-o-quinone	0.98	-

Attempts to reduce the isolated material (Fraction IB) to the parent compound using ascorbic acid, which has been successful in the case of  $\alpha$ -tocopheryloxide<sup>(24,29,30)</sup>, failed.

It is reasonably certain that this fraction is composed of an artefact of  $\gamma$ -tocopherol, but the structure of the compound is obscure. It probably contains the basic tocopherol ring structure with alkyl, ketonic and hydroxyl substituents. It could possibly be similar to the hemi-ketal type of structure (XXXI) which has been suggested by Harrison et al<sup>(24)</sup> as a possible common intermediate in reactions (1) and (2) below:-

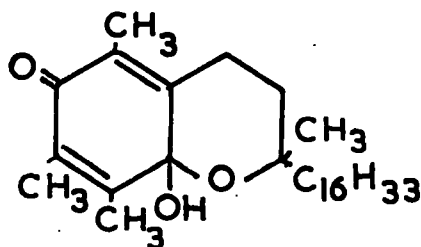
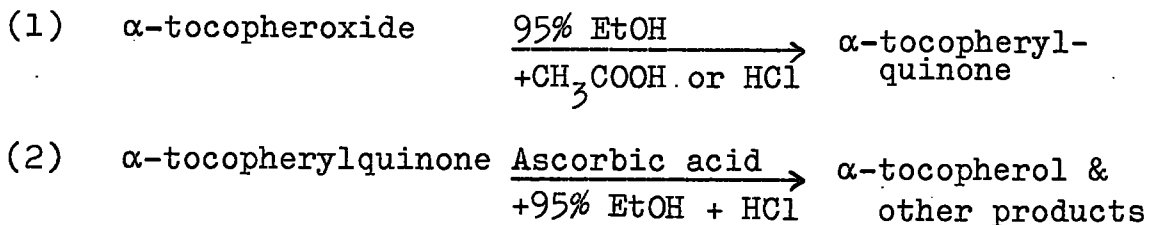

XXXI

In a structure of this type the tertiary hydroxyl group would not be nearly as polar as the phenolic -OH group at position 6- in a tocopherol structure; also, a considerable amount of protection would be afforded to a tertiary hydroxyl group in this position and therefore a structure of this type would be expected to appear chromatographically very much less polar than a tocopherol structure.

3.35 Fraction IV ( $\Delta^5$ -stigmasten- $3\beta$ -ol)

The positive Salkowski and Liebermann-Burchard colour reactions suggest that this fraction was composed of a sterol. The latter test also gives a positive result with triterpenoids but the colours produced are generally red, pink, or purple in this case, as opposed to the blue/green colours suggestive of steroids<sup>(58)</sup>. The Liebermann-Burchard test is stated to be positive for stenols and negative for stanols<sup>(59a)</sup>, but there are many exceptions. A recent paper on this test makes a few more valid generalisations<sup>(60)</sup>, viz., that a blue-green colour is obtained only when a complete nineteen carbon

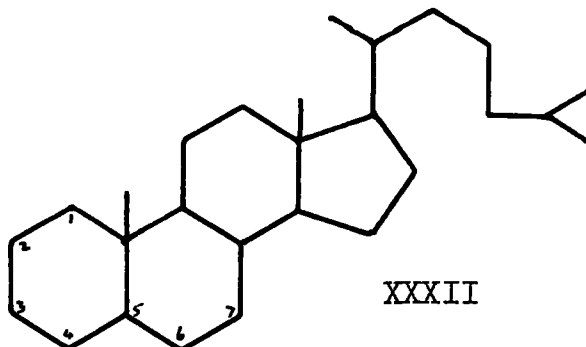

steroid skeleton and a side chain of at least eight carbon atoms are present - that the group attached to  $C_3$  (XXXII) may be a free or esterified hydroxyl

group (axial conformation is the more reactive) - the presence of a double bond, or an incipient double bond at C<sub>7</sub> confers increased reactivity - and if unsaturation is present at C<sub>7</sub> then an oxo-substituent at C<sub>3</sub> would give a positive result.

The infra-red and ultra-violet absorption spectra indicated the presence of a hydroxyl group and unsaturation of the R<sub>1</sub>R<sub>2</sub>C = CHR<sub>3</sub> type and the formation of an insoluble digitonide suggests a 3β-sterol<sup>(59b)</sup>.

Cole, Jones and Dobriner<sup>(61)</sup> have considered the hydroxyl absorption band position in the 995-1055 cm.<sup>-1</sup> region of the infra-red, with relation to the stereochemical configuration of rings A and B of 3-hydroxysteroids, and have found that certain configurations are associated with different positions of the hydroxyl group absorption in this region (Table XXXIII). The hydroxyl group of the sterol isolated from tung oil was found to absorb at 1053 cm.<sup>-1</sup>, which is in the position quoted by Cole et al for the hydroxyl group of a 3β-Δ<sup>5</sup>-sterol..

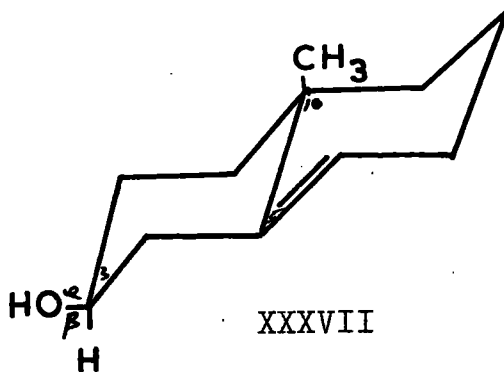
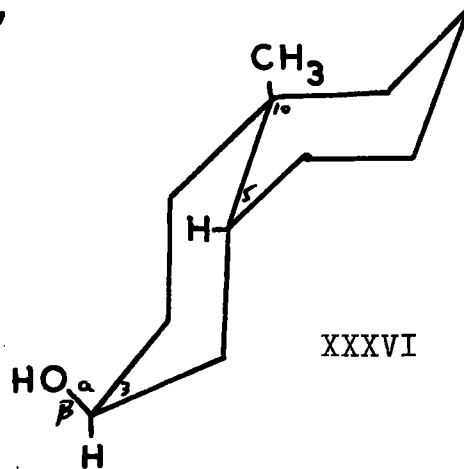
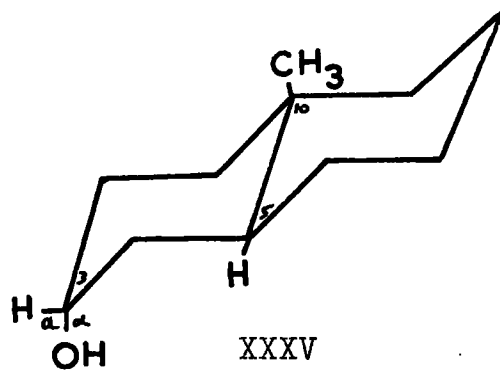
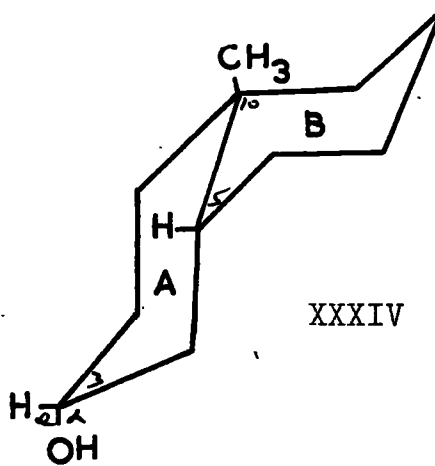
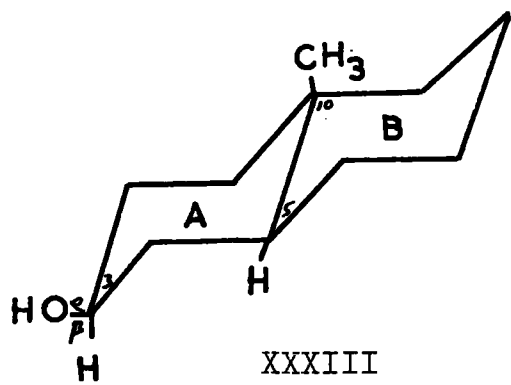

Table XXXIII: Position of -OH group absorption in the 995-1055  $\text{cm.}^{-1}$  region of the infra-red for various stereochemical configurations of 3-hydroxysteroids<sup>(61)</sup>

<u>Structure</u>	<u><math>\nu</math> (<math>\text{cm.}^{-1}</math>)</u>	<u>Digitonin</u>
XXXIII	1037-1040	Precipitate
XXXIV	1037-1044	No Precipitate
XXXV	996-1002	No Precipitate
XXXVI	1032-1036	Precipitate
XXXVII	1050-1052	Precipitate
Tung Oil Sterol (this work)	1053	Precipitate

The infra-red absorption spectrum of the acetate of the isolated material (Fig. 8) indicates that the isolated compound is a  $3\beta$ -hydroxy- $\Delta^5$ -steroid, as the absorption bands correspond exactly with those reported<sup>(62,63)</sup> for acetates of this type of structure (Tables XXXIV, XXXV).

Table XXXIV: Infra-red absorption bands of  $3\beta$ -acetoxy- $\Delta^5$ -steroids, below  $1350 \text{ cm.}^{-1}$

<u>Jones and Herling (62)</u>		<u>Acetate of sterol from tung oil - this work (see Fig. 8)</u>
<u><math>\nu</math> (cm.<sup>-1</sup>)</u>	<u>Rating</u> <sup>*</sup>	<u><math>\nu</math> (cm.<sup>-1</sup>)</u>
A 1318-1314	3	1315
B 1244-1241	1	1240
C 1204-1197	3	1195
D 1168-1160	3	1160
E 1138-1135	2	1132
F 1037-1030	1	1030
G 1027-1018	3	inflexion 1020
H 995-984	3	990
I 981-974	3	973
J 961-954	2	955
K 944-935	3	938
L 923-913	3	925 and 915
M 905-902	2	900
N 884-875	3	875
O 844-834	2	835
P 816-808	2	808
Q 800-796	2	796
R 738-730	3	not present

<sup>\*</sup> Rating - 1. refers to prominent bands  
 2. refers to confirmatory bands  
 3. refers to bands which may be present in more simple structures.

Table XXXV: Complexity of C-O stretching absorption in the 1200-1260  $\text{cm.}^{-1}$  region of the infra-red for various stereochemical configurations of acetoxysteroids(63).

<u>Structure</u>	<u><math>\nu(\text{cm.}^{-1})</math></u>	<u>No. of Peaks</u>
XXXIII	1200-1260	single
XXXIV	"	"
XXXV	"	2-3 strong peaks
XXVI	"	"
XXVII	"	single
12 $\alpha$ -acetates	1240-1242	"
12 $\beta$ -acetates	1232-1235	"
17 $\beta$ -acetates	1242	"
Tung oil sterol acetate (this work)	1240	"

The fact that the isolated material was a  $3\beta$ - $\Delta^5$ -sterol was confirmed by the molecular rotation differences between the isolated parent compound and its derivatives (Table XXXVI) and the specific and molecular rotations obtained agree with those reported for  $\Delta^5$ -stigmasten- $3\beta$ -ol (' $\beta$ -sitosterol') and its derivatives (Tables XXXVII, XXXVIII).

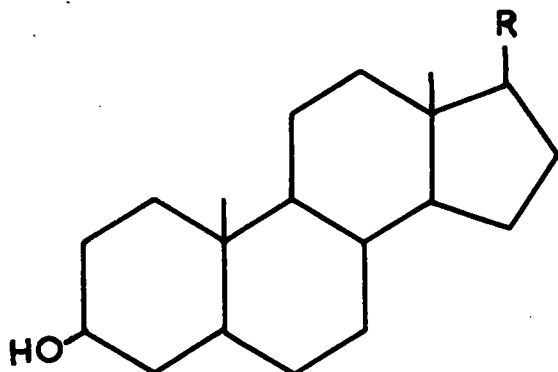

XXXVIII	:	as above	XLII	:	$\Delta^7$
XXXIX	:	$\Delta^5$	XLIII	:	$\Delta^{8,9}$
XL	:	$\Delta^{8,14}$	XLIV	:	$\Delta^{9,11}$
XLI	:	$\Delta^{14}$	XLV	:	$\Delta^5, \Delta^7$

Table XXXVI: Molecular rotation differences between various 3-sterol structures and their derivatives<sup>(64)</sup>.

Basic Structure	$\Delta_1$	$\Delta_2$	$\Delta_4$
XXXVIII	-26/-45	+5(one result)	-15/+13
XXXIX	-27/-45	+65/+92	+65/+90
XL	-23/-44	-42/-43	-
XLI	-30/-32	+9/+29	-
XLII	-6(variable)	+6/+35	-
XLIII	+15(only one result recorded)		-
XLIV	-47/-56	-2/+8	-
XLV	+77/+156	+170/+199	-
Isolated Sterol (This work - Fraction IV)	-26	+93	+99

$\Delta_1$	=	$[M]_D$	of parent alcohol	-	$[M]_D$	of its acetate
$\Delta_2$	=	$[M]_D$	" " "	-	$[M]_D$	of its benzoate
$\Delta_4$	=	$[M]_D$	" " "	-	$[M]_D$	of its 3,5-dinitro - benzoate

**Table XXXVII:** Molecular rotations of the more abundant phytosterols and their derivatives (64, 59c)

Compound	Sterol	Acetate	Benzoate	3.5 Dinitrobenzoate	$\Delta_1$	$\Delta_2$	$\Delta_4$
$\alpha_1$ -sitosterol	-8	+132	+217	+224	+140	+225	+232
$\alpha_2$ -sitosterol	+17	+80	+143	+161	+61	+126	+144
$\alpha_3$ -sitosterol	+16	+27	+72	+85	+11	+56	+69
$\beta$ -sitosterol	-149	-178	-73	-61	-29	+76	+88
$\gamma$ -sitosterol	-178	-210	-104	-	-32	+74	-
$\delta$ -sitosterol	-99	-109	-83	-	-10	+16	-
$\epsilon$ -sitosterol	-162	-205	-	-	-43	-	-
Stigmasterol	-202	-241	-129	-133	-39	+73	+69
Brassicasterol	-255						
Campesterol	-131						
Spinasterols	-16 - +25						
Fucosterol	-157						
Isolated $\beta$ -sitosterol (XLVIII)	-166	-192	-73	-67	-26	+93	+99
(this work)							

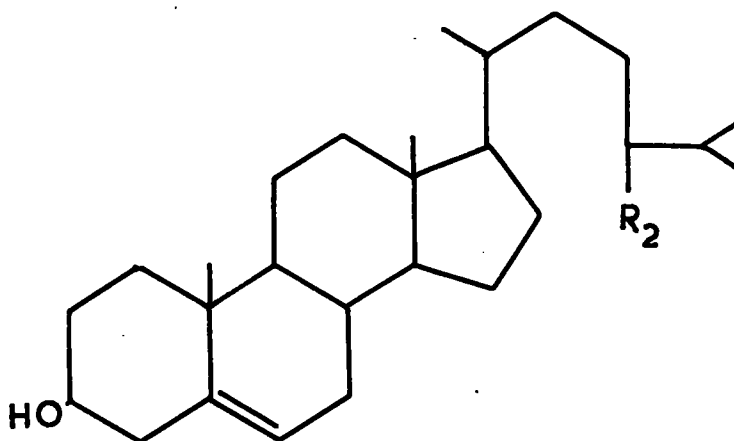

- XLVI : R<sub>1</sub> = -H; R<sub>2</sub> = -C<sub>2</sub>H<sub>5</sub>; Δ<sup>8,14</sup>  
 XLVII : R<sub>1</sub> = -CH<sub>3</sub>(α); R<sub>2</sub> = =CH·CH<sub>3</sub>; Δ<sup>7</sup>  
 XLVIII : R<sub>1</sub> = -H; R<sub>2</sub> = -C<sub>2</sub>H<sub>5</sub>

Barton<sup>(64)</sup> has suggested that the α-sitosterols (α,-XLVI) may on re-examination be assigned a C<sub>30</sub> formulation and brought into the triterpenoid class as optical rotation data makes a steroidal structure unlikely. A later suggestion by Mazur, Weismann and Sondheimer<sup>(65)</sup> that the α-sitosterols could be mixtures of, for example, citrostadienol (4α-methyl-24-ethylidene-Δ<sup>7</sup>-cholesten-3β-ol (XLVII)) and β-sitosterol (XLVIII) (or other Δ<sup>5</sup>-3β-sterol) which have sharp melting points, places some doubt on the existence of the α-sitosterols.

**Table XXVIII:** Summary of melting point and optical rotation data for the  $\beta$ -sitosterol isolated from tung oil and comparison with previously reported results

	Isolated Material						Reported Values			
	Analysis (%)			Calcd. H	m.p.		Ref.(66) m.p.(°C)	Ref.(67) m.p.(°C)	Ref.(66) [ $\alpha$ ] <sub>D</sub> <sup>25</sup>	Ref.(67) [ $\alpha$ ] <sub>D</sub> <sup>18</sup>
	Found C	H	C		°C.	[ $\alpha$ ] <sub>D</sub>				
$\beta$ -sitosterol	82.67	12.41	82.20 (for C <sub>29</sub> H <sub>50</sub> O· $\frac{1}{2}$ H <sub>2</sub> O)	12.13	134.5- 135.0	-40	135	139-140	-37	-35
Acetate	81.61	11.34	81.58	11.60	120.5- 121.5	-42	125	129-130	-41.5	-44
Benzoate	83.27	10.59	83.34	10.49	146.5	-14	144	146-147	-14.5	-12
3.5 Dinitro- benzoate	71.09	9.20	70.90	8.76	201.0- 202.0	-11	201	200-201	-	-11
3.5 Dinitro- phenylurethan	69.16	8.58	69.20	8.71	159.0- 159.5	-	-	-	-	-

The infra-red and ultra-violet absorption spectra and the melting point of a purified commercial sample of ' $\beta$ -sitosterol' were identical with those of the isolated material, and zero depression of the mixed melting point confirmed the identity of this material as  $\Delta^5$ -stigmasten- $3\beta$ -ol.

The molar extinction coefficients for the isolated material at various wavelengths are compared in Table XXI with those previously reported<sup>(31)</sup>. However, accuracy below 205-210  $\mu$  is open to question due to stray light errors<sup>(68)</sup>.

It is well known that  $3\beta$  hydroxy steroids isolated from plant sources may contain water of crystallisation which is difficult to remove<sup>(69)</sup> and only recently analysis figures for an isolated sample of  $\beta$ -sitosterol were said to be "in good agreement with calculated values for sitosterol with one molecule of water"<sup>(70)</sup>. It was found to be impossible to free the  $\beta$ -sitosterol isolated from tung oil, in this work, from the presence of moisture by prolonged drying at 110°C./0.05 mm. and the product analysed for  $C_{29}H_{50}O \cdot \frac{1}{2}H_2O$  (Table XXXVIII).

$\beta$ -sitosterol is widely distributed in the unsaponifiable matter of natural oils and has been reported by P. Capella, et al<sup>(71)</sup>, as the major constituent of the unsaponifiable content of olive, soybean, teaseed and rapeseed oils. This ubiquitous compound has also been found in wood<sup>(72)</sup>, bark<sup>(73)</sup>, leaves<sup>(66b)</sup>, etc.<sup>(69)(74)</sup>.

### 3.36 Fraction V (Glyceryl ester)

It would appear that this material is composed largely of partially saponified material as conjugated triene bands (260, 271 and 283  $\mu$ ) were found in the aqueous phase on extraction after re-saponification. From the infra-red and ultra-violet absorption spectra it would seem as though the isolated material was at least in part glyceryl  $\alpha$ -monoelaeostearin as conjugated triene,  $-C=O$  (ester),  $-CH_3$ , and secondary and primary alcohol groups appear to be present. The infra-red absorption spectrum is similar to that of glyceryl  $\alpha$ -mono-olein (Fig. 9) except that the band at about  $1177\text{ cm.}^{-1}$  ( $-C-O$  ester) is missing for the isolated material (there is, however, a small additional band at  $1212\text{ cm.}^{-1}$ ) and the band at  $1285\text{ cm.}^{-1}$  is probably not resolved in the case of  $\alpha$ -mono-olein.

It is presumed that the isolated material contains some small quantity of linolein, olein and/or saturated ester as triglycerides of these acids occur in the original tung oil (Table II).

No evidence was found in this work for the presence of  $\alpha$ -glyceryl ether in the unsaponifiables of tung oil.

The evidence for this material being present to a significant extent (1.9 per cent) in the tung oil unsaponifiables examined by Karnovsky and Rapson<sup>(14)</sup> (Section 1.22), rests with the fact that formaldehyde was liberated on oxidation with periodic acid.

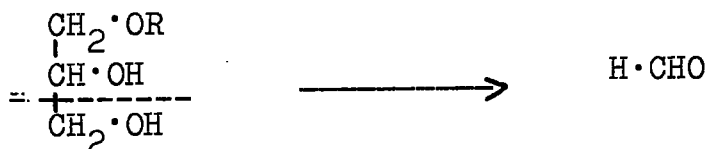

No attempt, however, appears to have been made by these workers to estimate the efficiency of their saponification stage, and if  $\alpha$ -glyceryl ester were present this would also yield formaldehyde on oxidation with periodic acid.  $\alpha$ -glyceryl ethers have been isolated from numerous animal sources but the only report of their occurrence in vegetable oils is by Karnovsky and Rapson, who found trace quantities in the unsaponifiable material from sesame (0.2 per cent) and castor (0.2 per cent) oils in addition to the 1.9 per cent from the unsaponifiables of tung oil<sup>(14)</sup>.

3.37 Fraction VI

This intensely green coloured labile material was obtained in insufficient quantity for any conclusions to be drawn regarding its composition.

3.38 Carotenoid pigment

A carotenoid pigment content of 6  $\mu\text{g.}/\text{g.}$  oil (0.14 per cent of the unsaponifiables) was found. This is of the same order as that found by Tošić and Moore for the tung oil they examined<sup>(12)</sup>.

4. SUMMARY

The composition of the unsaponifiable material present in tung oil has been examined in order to ascertain whether the gelation time of the oil at  $276 \pm 1^\circ\text{C}$ . was affected by any trace catalyst, or inhibitor, present in this part of the oil. No difference in gelation time was observed when oils derived from the Aleurites montana and Aleurites fordii species were reinforced with isolated unsaponifiable materials.

A method for the separation of the unsaponifiable material present in the Aleurites montana oils examined, was developed using thin layer silicic acid chromatography. Column chromatography was then used - employing the same solvent systems as in the case of the thin layers - in order to separate sufficient quantities of the components for identification purposes.

Identification of the three major components -  $\alpha$ -tocopherol (9 per cent),  $\gamma$ -tocopherol (36 per cent), and  $\Delta^5$ -stigmasten- $3\beta$ -ol ( $\beta$ -sitosterol) (45 per cent) - was achieved using ultra-violet and infra-red absorption analysis, optical rotation data, etc., and

eventual comparison of the isolated material with authentic samples. A fourth fraction was identified as an artefact of  $\gamma$ -tocopherol (4 per cent) which was probably formed by autoxidation during the original processing of the oil; the properties of this material did not correspond with those of any known structure. Infra-red and ultra-violet absorption spectra showed the presence of the tocopherol ring structure, a carbonyl group, and a hydroxyl group, but the material was chromatographically very much less polar than the tocopherols. A possible type of structure is suggested for this component. The carotenoid pigment content of the unsaponifiable material was found to be 0.14 per cent as  $\beta$ -carotene (determined on the original oil).

The possible presence of squalene or material of similar structure, to the extent of up to 1 per cent was noted, but no definite conclusion could be arrived at due to the small quantity present in the oil. It is suggested that the previously reported figure of 6 per cent for the squalene content of tung oil unsaponifiables is probably incorrect due to the method of estimation adopted.

It is also suggested that the method of estimation of the  $\alpha$ -glyceryl ether content of the unsaponifiable material from tung oil by previous workers is open to criticism as no evidence was found in the work now being reported for the presence of this type of structure. Inefficient saponification however, accounted for the presence of some 3 per cent of partially saponified material in the isolated unsaponifiables, and if this were present as  $\alpha$ -glyceryl ester in the unsaponifiable material isolated by the other workers it would have been estimated as  $\alpha$ -glyceryl ether.

5. REFERENCES

1. Fonrobert, E., 'Das Holzöl', 1951, p.328 (Berliner Union, Stuttgart.).
2. 'Vegetable Oils and Oilseeds', 1961, p.185 (Commonwealth Economic Committee - H.M.S.O. London).
3. 'The Wealth of India', Vol. 1, 1948, p.p. 45-49 (Council of Scientific and Industrial Research, Delhi.).
4. Raymond, W.D. and Ward, J.B., Colonial Plant and Animal Products, 6(1956)120.
5. Cutting, C.V., J.Sci.Food Agric., 3(1952)510.
6. Hilditch, T.P. and Mendelowitz, A., ibid., 2(1951)548.
7. Jordan, L.A., J.Oil Col.Chem.Assoc., 35(1952)577.
8. Hilditch, T.P., Offical Digest (Fed.Soc.Paint Technol.) 31(1959)975.
9. Zielenski, W.L., Mosley, W.V. and Bricker, R.C., ibid., 33(1961)622.
10. Fonrobert, E., 'Das Holzöl', 1951, p.109.
11. Bilger, L.N. and Westgate, J.M., Hawaii Agr.Expt.Sta. Ann. Rept., 1937(1938)54.(C.A. 35(1941)2022.).
12. Tošić, J. and Moore, T., Biochem.J., 39(1945)498.
13. Dickhart, W., Am.J.Pharm., 127(1955)359.
14. Karnovsky, M.L. and Rapson, W.S., J.Soc.Chem.Ind., 65(1946)138,425.
15. Kubin, H. and Fink, H., Fette Seifen Anstrichmittel, 63(1961)280.
16. Hilditch, T.P., Morton, R.A., and Riley, J.P., Analyst, 70(1945)68.
17. Hoffmann, J.S., O'Connor, R.T., Heinzelman, D.C., and Bickford, W.G., J.Amer.Oil Chem.Soc., 34(1957)338.
18. Stahl, E., Pharmazie, 11(1956)633.
19. Seher, A., Mikrochimica Acta, 1961, 308.

20. Demole, E., *J.Chromatog.*, 6(1961)2.
21. Smith, L.I. and Sprung, J.A., *J.Amer.Chem.Soc.*  
64(1942)433.
22. Vitamin-E Panel (Analytical Methods Committee of  
the Society for Analytical Chemistry), *Analyst*,  
84(1959)356.
23. Kodicek, E. and Ashby, D.R., *Biochem.J.*, 57(1954)xii.
24. Harrison, W.H., Gander, J.E., Blakley, E.R. and  
Boyer, P.D., *Biochem. et Biophys. Acta*, 21(1956)150.
25. Eggitt, P.W.R. and Norris, F.W., *J.Sci.Food Agric.*,  
7(1956)493.
26. Emmerie, A. and Engel, C., *Rec.Trav.Chim.Pays-Bas*,  
58(1939)283.
27. Marcinkiewicz, S. and Green, J., *Analyst*, 84(1959)304.
28. Quaife, M.L., *J.Amer.Chem.Soc.*, 66(1944)308.
29. Boyer, P.D., *J.Amer.Chem.Soc.*, 73(1951)733.
30. Bouman, J. and Slater, E.C., *Biochem. et Biophys.*  
*Acta*, 26(1957)624.
31. Bladon, P., Henbest, H.B. and Wood, G.W., *J.Chem.Soc.*,  
1952,2737.
32. Bennett, G.J. and Uri, N., *Nature*, 192(1961)354.
33. Zechmeister, L., *Chem.Revs.*, 34(1944)267.
34. O'Connor, R.T., DuPre, E.F. and Feuge, R.O.,  
*J.Amer. Oil Chem.Soc.*, 32(1955)88.
35. Kirchner, J.G., Miller, J.M. and Keller, G.J.,  
*Anal.Chem.* 23(1951)420.
36. Blattná, J. and Davídek, J., *Experientia*, 17(1961)474.
37. Dhont, J.H. and deRooy, C., *Analyst*, 86(1961)74.
38. Wollish, E.G., Schmall, M. and Hawrylyshyn, M.,  
*Anal.Chem.* 33(1961)1138.
39. Green, J., Marcinkiewicz, S. and Watt, P.R., *J.Sci.*  
*Food Agric.* 6(1955)~~645~~274.

40. Pratt, E.F. and Trapasso, L.E., J.Amer.Chem.Soc., 82(1960)6405.
41. Magnusson, R., Acta Chem.Scand., 14(1960)1643.
42. Hemming, F.W., Morton, R.A. and Pennock, J.F., Biochem.J., 80(1961)445.
43. Fitelson, J., J.Assoc.Off.Agric.Chem., 26(1943)499,506.
44. Lambertsen, G. and Braekkan, O.R., Analyst, 84(1959)706.
45. Robeson, C.D., J.Amer.Chem.Soc., 65(1943)1660.
46. Eggitt, P.W.R. and Norris, F.W., J.Sci.Food Agric., 6(1955)689.
47. Baxter, J.G., Robeson, C.D., Taylor, J.D. and Lehman, R.W., J.Amer.Chem.Soc., 65(1943)918.
48. Quaife, M.L., J.Amer.Chem.Soc., 66(1944)308.
49. Lange, W., J.Amer.Oil Chem.Soc., 27(1950)414.
50. Lea, C.H. and Ward, R.J., J.Sci.Food Agric., 10(1959)537, 11(1960)212.
51. Boyer, P.D., J.Amer.Chem.Soc., 73(1951)733.
52. Martius, C. and Eilingsfeld, H., Biochem.Zeitschrift, 328(1957)507.
53. Frampton, V.L., Skinner, W.A., Cambour, P. and Bailey, P.S., J.Amer.Chem.Soc., 82(1960)4632.
54. Frampton, V.L., Skinner, W.A. and Bailey, P.S., Science, 116(1952)34.
55. Issidorides, A., J.Amer.Chem.Soc., 73(1951)5146.
56. Knopp, F.W. and Tappel, A.L., J.Amer.Oil Chem.Soc., 38(1961)151.
57. Inglett, G.E. and Mattill, H.A., J.Amer.Chem.Soc., 77(1955)6552.
58. Simes, J.J.H., Tracey, J.G., Webb, L.J. and Dunstan, W.J., Australian Phytochemical Survey, Bull. No. 281,1959,p.7. Commonwealth Scientific and Industrial Research Organisation, Melbourne.).

- 59.a. Shoppee, C.W. and Shoppee, E. in Rodd, E.H.,  
'Chemistry of Carbon Compounds', Vol.II, 1953,p.836.  
(Elsevier Publishing Co., London.)
- b. Idem., *ibid.*, p.804.
- c. Idem., *ibid.*, p.856.
60. Cook, R.P., *Analyst*, 86(1961)373.
61. Cole, A.R.H., Jones, R.N. and Dobriner, K.,  
*J.Amer.Chem.Soc.*, 74(1952)5571.
62. Jones, R.N. and Herling, F., *ibid.*, 78(1956)1152.
63. Jones, R.N., Humphries, P., Herling, F. and  
Dobriner, K., *ibid.*, 73(1951)3215.
64. Barton, D.H.R., *J.Chem.Soc.*, 1945, 813.
65. Mazur, Y., Weizmann, A. and Sondheimer, F., *Bull.*  
*Res.Council Israel*, 7A(1958)82.
- 66.a. Sinha, A., *Indian J.Appl.Chem.*, 23(1960)35.
- b. Idem., *ibid.*, 23(1960)40.
67. Weizmann, A., Meisels, A. and Mazur, Y., *J.Org.Chem.*,  
20(1955)1173.
68. Applewhite, T.H. and Micheli, R.A., *Tetrahedron*  
*Letters*, 1961,560.
69. Weizmann, A., and Mazur, Y., *J.Org.Chem.*, 23(1958)832.
70. Carter, H.E., Ohno, K., Nojima, S., Tipton, C.L. and  
Stanacev, N.Z., *J.Lipid Res.*, 2(1961)215.
71. Capella, P., de Zotti, G., Ricca, G.S., Valentini, A.F.  
and Jacini, G., *J.Amer.Oil Chem.Soc.*, 37(1960)564.
72. Akisanya, A., Bevan, C.W.L., Hirst, J., Halsall, T.G.  
and Taylor, D.A.H., *J.Chem.Soc.*, 1960, 3827.
73. Lawrie, W., McLean, J. and Taylor, G.R., *ibid.*, 1960,4303.
74. Abu-Mustafa, E.A., Fayez, M.B.E., Gad, A.M. and  
Osman, F., *J.Org.Chem.*, 25(1960)1269.

## COMPOSITION OF THE UNSAPONIFIABLE MATERIAL IN TUNG OIL

By G. SHONE

The unsaponifiable matter of an *Aleurites montana* tung oil (Nyasaland) has been examined and found to contain some 46% of  $\Delta^5$ -stigmasten-3 $\beta$ -ol, 9% of  $\alpha$ -tocopherol, 36% of  $\gamma$ -tocopherol, 3% of tocopherol artifact and 0.16% of carotenoid pigment (determined on the original oil). No evidence for the previously reported presence of  $\alpha$ -glyceryl ether or squalene to the extent suggested by former workers was found.

### Introduction

There are few references in the literature to the composition of the unsaponifiable content of tung oil. In 1938 it was reported<sup>1</sup> that a sterol (m.p. 130-136°), capable of being precipitated by digitonin, was present to the extent of some 37% of the unsaponifiable matter of this oil. Tošič & Moore later reported<sup>2</sup> the 'carotenoid pigment' content of the tung oil they examined to be 4  $\mu$ g./g. of oil ( $\equiv$  approx. 0.1% of the unsaponifiables) and also recorded a 'vitamin E' content of about 444  $\mu$ g./g. of oil ( $\equiv$  approx. 9% of the unsaponifiables); they did not, however, examine the nature of this 'vitamin E'. Squalene<sup>3</sup> has also been reported to occur to the extent of approximately 6% and  $\alpha$ -glyceryl ether<sup>4</sup> comprises 1.9% of the unsaponifiable material present in tung oil.

### Experimental and results

The tung oil used in this work was obtained from Vipya Tung Estates, Nyasaland, and was derived from nuts of the species *Aleurites montana*.

#### (1) Saponification

Tung oil (200 g.) was saponified for 1 h., in the presence of 5% pyrogallol<sup>5</sup> and under a nitrogen atmosphere, with 12% alcoholic potassium hydroxide (500 ml.). The apparent unsaponifiable matter was extracted with diethyl ether and recovered by evaporation of the ether in a nitrogen atmosphere. The residue (820-840 mg.) was dissolved in aromatics-free light petroleum (b.p. 60-80°) and the efficiency of saponification estimated by spectrophotometric determination of the conjugated triene content at 268  $m\mu$ .<sup>6</sup> Conjugated triene (estimated as elaeostearic acid) was found to be present to the extent of 1-3%.

#### (2) Separation of components

The method of separation of the component unsaponifiables was established by thin-layer chromatography.<sup>7</sup> Silica gel, 100-200 mesh (Griffin & George Ltd.) (80 g.), and plaster of Paris

(Hopkin & Williams Ltd.) (20 g.) were mixed into a slurry with water, and layers of thickness  $0.20 \pm 0.02$  cm. were produced on glass plates by a spreading technique. The prepared plates were then dried for 1.5–2 h. (this time was not critical) at  $100^\circ$  and cooled in a vacuum desiccator. Satisfactory separation of the component unsaponifiables was obtained by running with solvent mixtures as shown in Table I. Concentrated sulphuric acid, dispensed from a dropper, gave sensitive detection of the component spots after evaporation of the mobile phase.

Table I

*R<sub>F</sub> values of component unsaponifiables separated by thin-layer chromatography*

Solvent system	20% benzene/ L.P.	50% benzene/ L.P.	Benzene	5% ether/ benzene	15% ether/ benzene	50% ether/ benzene	100% ether
I A Fraction B	0.70 0.09	0.7–0.8	1.00				
II ( $\alpha$ -tocopherol)			0.40	0.56			
III ( $\gamma$ -tocopherol)			0.27	0.38	0.66	0.90	1.00
IV ( $\beta$ -sitosterol)				0.12	0.35	0.61	0.80
V						0.22	0.3–0.4
VI							0.00

$R_F$  of fraction V = 1.00 in acetone and of fraction VI = 1.00 in methanol  
L.P. = Light petroleum (b.p.  $40-60^\circ$ ), free from aromatic hydrocarbons

The residue from the saponification stage (approx. 830 mg.) was placed on a silica gel/plaster of Paris (80/20) column ( $60 \times 3.5$  cm.) containing 250 g. of stationary phase. Elution was carried out with (a) benzene 550 ml., (b) 5% diethyl ether in benzene 400 ml., (c) 50% diethyl ether in benzene 300 ml., (d) diethyl ether 300 ml., (e) acetone 150 ml., (f) methanol 200 ml. (all solvents A.R. grade), 50-ml. fractions being collected. The purity and content of each fraction tube was determined qualitatively by thin-layer chromatography and tubes bulked on the basis of this information (Table II).

Fraction I (Table II), eluted from the main column with benzene, was rechromatographed on a silica gel/plaster of Paris column with light petroleum (b.p.  $40-60^\circ$ )/benzene mixtures as mobile phase, and fractions IA and IB isolated (Tables I and II).

Table II

*Separation of component unsaponifiables on the main column*

Fraction	Tube no. (50 ml. capacity)	Wt. of fraction, %	Composition
I A } B }	1–3	{ 0.8 3.2	(Possibly squalene?) tocopherol artifact
II	5–7	9.1	$\alpha$ -tocopherol
III	9–16	36	$\gamma$ -tocopherol
IV	17–25	46	$\Delta^6$ -stigmasten-3 $\beta$ -ol (' $\beta$ -sitosterol')
V	28–33	3.5	$\alpha$ -glyceryl elaeostearin
VI	35–36	1.2	?

### (3) *Infra-red and ultra-violet absorption spectra*

The infra-red absorption spectra were measured on approximately 1–2% solutions in carbon disulphide in a Hilger H800 double beam spectrophotometer with rock-salt optics, and the ultra-violet absorption spectra on ethanolic solutions with either a Unicam SP500 or an Optica CF4 D.R. N.I. grating, double beam spectrophotometer.

### (4) *Identification of components*

*Fraction IA.*—This material gave a single spot by thin-layer chromatography, of the same  $R_F$  and of the same colour, after sulphuric acid treatment, as commercial squalene (Eastman Kodak Co.). The quantity of this fraction was insufficient for further investigation.

*Fraction IB.*—This unidentified material appears, from the absorption spectra, to be an oxidation product of one of the tocopherols and has the following absorption bands,  $\nu_{\max}$ . 1732 ( $-\text{C}=\text{O}$ ), 1615 (unsaturation), 1220 ( $-\text{OH}$ ), 1242, 1085 (chrom anether), 1094 (?)  $\text{cm.}^{-1}$   $\lambda_{\max}$ . 295  $\text{m}\mu$  ( $E_{1\text{cm.}}^{1\%}$  73),  $\lambda_{\min}$ . 263  $\text{m}\mu$ .

In the absence of pyrogallol in the saponification stage the quantity of this fraction was found to double (to approximately 6%).

*Fraction II.*—This fraction was liquid in character and gave infra-red and ultra-violet absorption bands at  $\nu_{\max}$ . 3578 ( $-\text{OH}$ ); 1263, 1085 (chroman ether)  $\text{cm.}^{-1}$ ;  $\lambda_{\max}$ . 292  $\text{m}\mu$  ( $E_{1\text{cm.}}^{1\%}$  72),  $\lambda_{\min}$ . 260  $\text{m}\mu$ . The 3,5-dinitrophenylurethane derivative<sup>8</sup> had m.p. 146–147° (Found, C, 67.63; H, 8.67%.  $\text{C}_{35}\text{H}_{53}\text{O}_7\text{N}_3$  requires C, 67.56; H, 8.34%).

When run on a paper chromatogram, in two dimensions, by the procedure recommended by the Vitamin E Panel,<sup>9</sup> the compound appeared in the  $\alpha$ -tocopherol position.

Oxidation with nitric acid under the conditions used by Eggitt & Norris<sup>10</sup> failed to produce an *o*-quinone (absence of absorption maximum between 400 and 650  $\text{m}\mu$ ) and attempts to produce the nitroso compound<sup>10</sup> also failed (pale yellow colour, small  $\lambda_{\max}$ . 365  $\text{m}\mu$ ). Both these results are in agreement with the properties of  $\alpha$ -tocopherol.<sup>10</sup>

A commercial sample of  $\alpha$ -tocopherol (Eastman Kodak Co.) gave infra-red and ultra-violet absorption spectra identical with those of the isolated material, and the m.p. (commercial sample) and mixed m.p. of the 3,5-dinitrophenylurethane derivatives were 146.5–147.5° and 146–147° respectively.<sup>8</sup>

The purity of the isolated material was established by (1) the extinction coefficient at 292  $\text{m}\mu$  (see above), (2) the ferric chloride/ $\alpha\alpha'$ -bipyridyl method of Emmerie & Engel<sup>11</sup> as recommended by the Vitamin E Panel<sup>9</sup> (but omitting the paper chromatography), (3) thin-layer chromatography, and (4) partition chromatography with the three mobile phases of Kodicek & Ashby.<sup>12</sup>

*Fraction III.*—This fraction was also liquid and gave infra-red and ultra-violet absorption maxima at  $\nu_{\max}$ . 3509 ( $-\text{OH}$ ), 1239, 1080 (chroman ether)  $\text{cm.}^{-1}$ ;  $\lambda_{\max}$ . 297  $\text{m}\mu$  ( $E_{1\text{cm.}}^{1\%}$  96),  $\lambda_{\min}$ . 260  $\text{m}\mu$ . The 3,5-dinitrophenylurethane<sup>8</sup> melted at 156–157.5° (Found, C, 67.48; H, 8.74%.  $\text{C}_{35}\text{H}_{51}\text{O}_7\text{N}_3$ , requires C, 67.17; H, 8.2%) and the 3,5-dinitrobenzoate at 94–96° (Found, C, 68.82; H, 8.77%.  $\text{C}_{35}\text{H}_{50}\text{O}_7\text{N}_2$  requires C, 68.81; H, 8.25%).

When chromatographed by the procedure referred to above<sup>9</sup> the compound appeared in the  $\beta$ - $\gamma$ -tocopherol position.

Oxidation with nitric acid gave the permanent red colour of the *o*-quinone of  $\lambda_{\max}$ . 480  $\text{m}\mu$  ( $\beta$ -tocopherol is reported to give a transient violet colour).<sup>10</sup> The nitroso compound gave an ultra-violet absorption spectrum which indicated that the isolated material was  $\gamma$ -tocopherol.<sup>10</sup> This was confirmed by condensing the tocopherol with *p*-nitrobenzenediazonium chloride which resulted in an azotocopherol being formed with  $\lambda_{\max}$ . 386, 532;  $\lambda_{\min}$ . 458  $\text{m}\mu$ . These absorption bands are in agreement with those reported for the  $\gamma$ -tocopherol derivative.  $\beta$ -Tocopherol does not condense with *p*-nitrobenzenediazonium chloride in the pH range 4.5–11.<sup>13</sup> When the tocopherol (on paper) was sprayed with a solution of ceric sulphate in 35% sulphuric acid, a violet-blue colour was produced (indicative of  $\gamma$ -tocopherol) rather than a brown colour which is formed with  $\beta$ -tocopherol.<sup>14</sup>

The infra-red and ultra-violet absorption spectra of this material were identical with those of a commercial sample of  $\gamma$ -tocopherol (Bios Laboratories Inc.) and the m.p. (commercial sample) and mixed m.p. of the 3,5-dinitrophenylurethane derivatives were 155.5–157 and 156–157° respectively.<sup>8</sup>

The purity of the isolated material was established by (1) the extinction coefficient at 297  $\text{m}\mu$  (see above), (2) the Emmerie–Engel method, (3) thin-layer chromatography and (4) the partition chromatographic techniques previously mentioned.

*Fraction IV.*—This fraction was composed of a white solid together with trace quantities of pigment. The solid was freed from pigment by crystallisation from light petroleum (b.p. 40–60°) at  $-80^\circ$ ; crystallisation from ethanol and then from light petroleum yielded white needle-like crystals of m.p. 134.5–135°.

The isolated compound appeared to be homogenous when subjected to thin-layer and partition chromatography with three solvent systems.<sup>12</sup> The compound gave positive

Salkowski (red) and Liebermann-Burchard (red → blue → green) colour tests and a precipitate with digitonin, which suggested a  $3\beta$ -sterol. Infra-red and ultra-violet spectra gave the following absorption bands:  $\nu_{\max}$ . 3582, 1053 (—OH), 1666, 832, 795 (unsaturation), 1376, 1367 (shoulder) (—CMe and —CMe<sub>2</sub>) cm.<sup>-1</sup>;  $\lambda_{\max}$ . 204 m $\mu$  ( $E_{1\%}^{1\text{cm}}$ . 64).

The acetate, benzoate, 3,5-dinitrobenzoate and 3,5-dinitrophenylurethane were prepared and melting points and optical rotations ( $\alpha$ -2% in chloroform) of these derivatives determined (Table III).

Table III

Characteristics of fraction IV

	Analysis (%)				m. p., °C	[ $\alpha$ ] <sub>D</sub>	[M] <sub>D</sub>	$\Delta$	$\Delta$ for $3\beta$ - $\Delta^5$ sterols <sup>18</sup>	[ $\alpha$ ] <sub>D</sub> *
	Found		Calc.							
	C	H	C	H						
Sterol	82.67	12.41	82.20 (for C <sub>29</sub> H <sub>50</sub> O, $\frac{1}{2}$ H <sub>2</sub> O)	12.13 11.60	134.5-135	-40	-166	—	—	-37
Acetate	81.61	11.34	81.58	11.60	120.5-121.5	-42	-192	-26	-29 (-27/-45)	-42
Benzoate	83.27	10.59	83.34	10.49	146.5	-14	-73	+93	+76 (+65/+92)	-14
3,5-Dinitrobenzoate	71.09	9.20	70.90	8.76	201-202	-11	-67	+99	+88 (+65/+90)	-10
3,5-Dinitrophenylurethane	69.16	8.58	69.20	8.71	159-159.5	—	—	—	—	—

\* Values of [ $\alpha$ ]<sub>D</sub> for  $\Delta^5$ -stigmasten- $3\beta$ -ol and derivatives quoted in 'Elsevier's Encyclopaedia of Organic Chemistry'.<sup>18</sup>

The infra-red spectrum of the acetate gave bands corresponding to those of  $3\beta$ - $\Delta^5$ -acetates as reported by Jones & Herling<sup>15</sup> and the molecular rotations are in agreement with figures for this class of sterol.<sup>18</sup>

Optical rotation and m.p. data suggest that this fraction is composed of  $\Delta^5$ -stigmasten- $3\beta$ -ol (' $\beta$ -sitosterol'). Infra-red and ultra-violet spectra of the material were identical with those of a purified commercial specimen of ' $\beta$ -sitosterol' (Nutritional Biochemical Corp.) and the mixed m.p. of 135-135.5° (commercial m.p. 134-135.5°) confirmed the identity of this material.

It is well known that  $3\beta$ -hydroxy-steroids may contain water of crystallisation which is difficult to remove<sup>17</sup> and it was found impossible to free this isolated sterol from the presence of moisture by prolonged drying at 110°/0.05 mm. The product analysed for C<sub>29</sub>H<sub>50</sub>O,  $\frac{1}{2}$ H<sub>2</sub>O.

**Fraction V.**—The ultra-violet absorption spectrum showed characteristic conjugated triene bands ( $\lambda_{\max}$ . 260, 271, 283 m $\mu$ ) suggesting partially saponified material (especially as the conjugated triene content varied with the saponification time). The fraction was re-saponified and extracted and the conjugated triene shown to be present in the aqueous extract, confirming the presence of partially saponified material after the saponification of the oil.

**Fraction VI.**—This material was labile in character, a colour change being observed shortly after isolation, from a bright copper-green to a dull grey-green, together with a marked change in solubility (in both carbon disulphide and light petroleum). The infra-red spectrum of the freshly isolated material showed absorption maxima at 1727 ( $\text{C}=\text{O}$ ) and 1605 (unsaturation) cm.<sup>-1</sup> The quantity of material isolated was insufficient for further investigation.

**Carotenoid pigment.**—Most of the yellow-orange colour was eluted from the chromatographic column together with the sterol. Carotene determination at 453 m $\mu$  on the sterol fraction gave a negative result, but absorption in the region 260-320 m $\mu$  was observed. It was thought that this absorption was due to oxidised carotenoid pigment and therefore the total unsaponifiable material was examined in the 450-m $\mu$  region before chromatography, as was the original tung oil before saponification. In the former case, 3  $\mu$ g./g. of oil ( $\equiv$ 0.08% of the unsaponifiables) of carotenoid pigment (as  $\beta$ -carotene at 453 m $\mu$ ) was determined and 6  $\mu$ g./g. ( $\equiv$ 0.16% of the unsaponifiables) in the latter. In both cases there remained a strong absorption in the 320-340 m $\mu$  region. The value 6  $\mu$ g./g. is of the same order as that found by Tošič & Moore,<sup>2</sup> for the tung oil they examined.

## Discussion

$\Delta^5$ -stigmasten-3 $\beta$ -ol is widely distributed in the unsaponifiable matter of natural oils and has been reported by Capella *et al.* to be the major constituent of the unsaponifiable content of olive, soya-bean, teaseed and rapeseed oils.<sup>19</sup>

The tocopherols occur to some extent in most natural oils, but their abundance varies greatly, up to about 500 mg./100 g. in the case of wheat germ oils.<sup>20</sup> There appears to be no pattern to the occurrence of the individual tocopherols in various environments. The melting point of the 3,5-dinitrophenylurethane derivative of  $\gamma$ -tocopherol reported in this paper (156–157.5°) differs from that previously published (143–145°).<sup>8</sup>

The tocopherol artifact (fraction IB) was probably not formed in the saponification stage, as the presence of pyrogallol reduced the quantity of the fraction by about 50%, suggesting that the pyrogallol was an effective oxidation inhibitor. An increase in the time of saponification or of the quantity of the inhibitor present had no effect on the quantity of the fraction isolated. It would appear that this artifact was present in the oil and was probably formed by oxidation during extraction and/or subsequent storage.

Squalene has been reported by Dickhart<sup>3</sup> to be present in rapeseed, palm and tung oils to the extent of 15–20 mg./100 g. oil ( $\approx$ approximately 3–6% of the unsaponifiables). The possible occurrence of squalene to the extent of only 0.8% of the unsaponifiable matter of tung oil, reported in this paper, is not surprising when the method of estimation of squalene content used by Dickhart is examined. The least polar material from the unsaponifiables of tung oil was eluted from an alumina chromatographic column with light petroleum and the whole of the measured unsaturation of this material was assumed to be due to the presence of squalene. The homogeneity of the eluted material was not examined and it is likely that squalene, if present, was accompanied by other unsaturated material.

$\alpha$ -Glyceryl ether was reported by Karnovsky & Rapson<sup>4</sup> to be present in the unsaponifiables of sesame (0.2%), castor (0.2%), and tung (1.9%) oils. The evidence for this rests on the fact that formaldehyde was liberated on oxidation of the unsaponifiable matter of these oils with periodic acid. In the present work no evidence was found for the presence of  $\alpha$ -glyceryl ether, but the presence of a small quantity of partially saponified material was noted. From the ultra-violet absorption spectra and  $R_F$  values, it would appear that this material is glyceryl monoelaeostearin, which, if present as the  $\alpha$ -isomer, would also yield formaldehyde on oxidation with periodic acid. It may well be that the 1.9% of  $\alpha$ -glyceryl ether reported by Karnovsky & Rapson was largely  $\alpha$ -glyceryl ester, as no estimate of the efficiency of saponification appears to have been made.

## Acknowledgments

The author wishes to express his thanks to Miss P. J. Rose for experimental assistance, the Physical Chemistry Section of the Tropical Products Institute for the analytical, infra-red and (in part) ultra-violet absorption results presented in this paper, and to the Colonial Development Corp. for the sample of tung oil.

(Crown copyright reserved)

Tropical Products Institute  
56–62 Gray's Inn Road  
London, W.C.1

Received 1 November, 1961

## References

- <sup>1</sup> Bilger, L. N., & Westgate, J. M., *Hawaii agric. Exp. Sta., Annu. Rep. 1937*, p. 54 (*Chem. Abstr.*, 1941, **35**, 2022)
- <sup>2</sup> Tošič, J., & Moore, T., *Biochem. J.*, 1945, **39**, 498
- <sup>3</sup> Dickhart, W., *Amer. J. Pharm.*, 1955, **127**, 359
- <sup>4</sup> Karnovsky, M. L., & Rapson, W. S., *J. Soc. chem. Ind., Lond.*, 1946, **65**, 138, 425
- <sup>5</sup> Kubin, H., & Fink, H., *Fette Seif. Anstrichm.*, 1961, **63**, 280
- <sup>6</sup> Hilditch, T. P., Morton, R. A., & Riley, J. P., *Analyst*, 1945, **70**, 68
- <sup>7</sup> Kirchner, J. G., Miller, J. M., & Keller, G. J., *Analyt. Chem.*, 1951, **23**, 420
- <sup>8</sup> Smith, L. I., & Sprung, J. A., *J. Amer. chem. Soc.*, 1942, **64**, 433
- <sup>9</sup> Vitamin E Panel, *Analyst*, 1959, **84**, 356
- <sup>10</sup> Eggitt, P. W. R., & Norris, F. W., *J. Sci. Fd Agric.*, 1956, **7**, 493

## References (cont.)

- <sup>11</sup> Emmerie, A., & Engel, C., *Rec. Trav. chim. Pays-Bas*, 1939, **58**, 283
- <sup>12</sup> Kodicek, E., & Ashby, D. R., *Biochem. J.*, 1954, **57**, xii
- <sup>13</sup> Quaife, M. L., *J. Amer. chem. Soc.*, 1944, **66**, 308
- <sup>14</sup> Seher, A., *Mikrochim. Acta*, 1961, 308
- <sup>15</sup> Jones, R. N., & Herling, F., *J. Amer. chem. Soc.*, 1956, **78**, 1152
- <sup>16</sup> Barton, D. H. R., *J. chem. Soc.*, 1945, p. 813; 1946, p. 512; Klyne, W., 'Determination of Organic Structures by Physical Methods' (Eds. Braude, E. A., & Nachod, F. C.), 1955, p. 108 (New York: Academic Press Inc.)
- <sup>17</sup> Weizmann, A., & Mazur, Y., *J. org. Chem.*, 1958, **23**, 832
- <sup>18</sup> 'Elsevier's Encyclopaedia of Organic Chemistry', 1940, **14**, p. 90 (New York: Elsevier Publishing Co.)
- <sup>19</sup> Capella, P., de Zotti, G., Ricca, G. S., Valentini, A. F., & Jacini, G., *J. Amer. Oil Chem. Soc.*, 1960, **37**, 564
- <sup>20</sup> Lange, W., *J. Amer. Oil Chem. Soc.*, 1950, **27**, 414

