

## Durham E-Theses

---

### *Roman glass with special reference to material from North Britain*

Winifred Jane Halliday

#### How to cite:

---

Halliday, Winifred Jane (1971) Roman glass with special reference to material from North Britain. Masters thesis, Durham University.

#### Use policy

---

The full-text may be used and/or reproduced, and given to third parties in any format or medium, without prior permission or charge, for personal research or study, educational, or not-for-profit purposes provided that:

- a full bibliographic reference is made to the original source
- a <https://etheses.durham.ac.uk/id/eprint/10081/> is made to the metadata record in Durham E-Theses
- the full-text is not changed in any way

The full-text must not be sold in any format or medium without the formal permission of the copyright holders.

Please consult the [full Durham E-Theses policy](#) for further details.



ROMAN GLASS, WITH SPECIAL REFERENCE TO  
MATERIAL FROM NORTH BRITAIN.

A Thesis submitted for the M.A. Degree, University of Durham, 1971,  
by Winifred Jane Halliday, B.A., St. Mary's College, Durham.

SYNOPSIS.

This work is divided into three Sections. The first considers the ancient glass industry as a whole; the second limits the subject historically to the Roman period; in the third the subject is further limited geographically to Roman Glass from North Britain.

The opening section considers the ancient glass industry, its origins and history in pre-Roman and Roman times, and the technology of ancient glass, its compositions, manufacture, colour, and the different methods by which vessels were produced.

The second Section specifically concerns Roman glass. It begins with an account of possible glass-producing centres in Roman Britain, notably Wilderspool, Caistor by Norwich, Colchester and Mancetter. There follows a consideration of sites in Egypt, Europe and Britain where Roman glass has been found, together with their relative importance and a discussion of published works on Roman glass. The archaeological approach to the dating of glass by examination of the stratification and history of the sites on which examples have been found is also described.

In the third Section, 35 types of glass vessels found in North Britain are described in seven basic groups: unguentaria, flasks, flagons, bottles, jars, beakers, bowls and plates, following the progression from narrow vessels to broad. In each case a description of the type is given; the possible place of manufacture; North British examples; and parallels from elsewhere. Finally dating evidence is given, and a date based on this is suggested for each type. Interspersed between the types are four short notes on techniques used to decorate vessels. This section is illustrated by nine pages of Figures.

There are three appendices. Two consider snakethread glass and the weathering of glass. The third is a report on the Roman glass found recently at Malton.

September 1971.

ACKNOWLEDGEMENTS.

In producing this thesis I have visited several museums and corresponded with a number of archaeologists to obtain information. I would like to record here my thanks to them and to everyone who has made this work possible.

I am indebted to the curators and staff of the following museums for their help, and where indicated for supplying illustrations.

Chesters Museum, Northumberland.  
Corstopitum Museum, Corbridge, Northumberland.  
The Guilbenkian Museum, Durham. (Plates I, II, XIV.)  
Housesteads Museum, Northumberland.  
The Manchester Museum. (Plate VII).  
The Museum of Antiquities, Newcastle.  
The National Museum, Copenhagen. (Plates IX, X.)  
Tullie House Museum, Carlisle. (Plate V.)  
The Yorkshire Museum, York.

Also to Miss D. Charlesworth, for allowing me access to an unpublished report on material from Verulamium and for her help and encouragement; Mrs. B. Hartley for information concerning the Mancetter excavation discussed in Chapter 3; and M. R. Hull Esq. for information concerning the possible glass production at Colchester.

In the University of Durham, I wish to thank all my colleagues in the Department of Archaeology for their suggestions for this work. To Mr. Michael Harman I am most grateful for his help in producing the illustrations, and to Mr. T. Middlemass for all the photographic work involved. I am particularly indebted to Mr. Wilfred Dodds for his suggestions and help, and to Professor Eric Birley, on whose suggestion this work was begun and without whose guidance it would never have been completed.

## Glass.

"There is no nobler material conceived by the mind of man or created by his hand, for it is not only shadowless but has become in the passage of centuries, in splendour and variety of colour, the greatest triumph of human skill."

J<sup>r</sup>. Neuburg.

"Glass in Antiquity."

C O N T E N T S

	<u>Page</u>
Synopsis	(i)
Acknowledgements	(ii)
Contents	(iii)
List of Illustrations	(v)
Bibliography	(vi)
Preface	(xi)

. . . . .

<u>SECTION I.</u>	<u>The History and Technology of Ancient Glass</u>	
	Chapter 1. The Origin and History of the Glass Industry	1.
	Chapter 2. The Composition and Manufacture of Glass Vessels in Pre-Roman and Roman Times	9.
<u>SECTION II.</u>	<u>Roman Glass.</u>	
	Chapter 3. Evidence for Glass Making in Roman Britain.	15.
	Chapter 4. The Significance of Roman Glass from Sites in Southern Britain and Elsewhere.	23.
	Chapter 5. The Dating of Roman Glass from Sites in North Britain.	33.
<u>SECTION III.</u>	<u>Types of Roman Glass Vessels in North Britain.</u>	
	Unguentaria.	45.
	Flasks	54.
	Flagons	57.
	Bottles.	63.

Note 1. Decorated Cylindrical Bottles.	64.
Note 2. Moulded Designs on the Bases of Glass Bottles.	67.
Jars.	69.
Beakers.	72.
Bowls and Plates	78.
Note 3. Painted Glass Bowls.	79.
Note 4. Bowls with Engraved Christian Symbols, and Figures.	81.

FIGURES TO ILLUSTRATE SECTION III. 86-94.

APPENDICES.

Appendix 1. Snake Thread Glass.	95.
Appendix 2. The Weathering of Glass.	96.
Appendix 3. A Report on the Roman Glass from Malton.	98.

.....

LIST OF ILLUSTRATIONS.

<u>Plate</u>		<u>Page.</u>
I	Early Egyptian Glass Vessels.	2a
II	Unguentarium Produced by the Sand-Core. Process.	13a
III	Unguentaria.	45a
IV.	Glass Flagon from Corstopitum.	58a
V	Square Bottle used as a Cinerary Urn.	65a
VI	Moulded Designs on Bases of Glass Bottles.	68a
VII	Facet-Cut Beaker.	74a
VIII	Fragments of Painted Glass Bowls.	79a
IX	Painted Glass Bowl from Scandinavia.	79b
X	Painted Glass Bowl from Scandinavia.	79c
XI	Fragments of Bowls with Engraved Christian Symbols.	81a
XII	Fragments of Bowls with Engraved Figures (1).	81b
XIII	Fragments of Bowls with Engraved Figures (2).	81c
XIV	Pillar-Moulded Bowl.	83a
XV	Fragments of Snake Thread Glass.	95a
XVI	Roman Glass from Malton	103a

BIBLIOGRAPHY.

- AA Archaeologia Aeliana (Journal of the Society of Antiquaries of Newcastle upon Tyne).
- Arch J. Archaeological Journal.
- CW Transactions of the Cumberland and Westmorland Antiquarian and Archaeological Society.
- PSAS Proceedings of the Society of Antiquaries of Scotland.
- RSAL Reports of the Research Committee of the Society of Antiquaries of London.
- . . . . .
- ATKINSON D. 1930.  
"Caistor Excavations 1929."  
Norfolk Archaeology, Vol. XXIV.
- ATKINSON D. 1942.  
"Report on Excavations at Wroxeter (the Roman City of Viroconium) in the County of Salop. 1923-1927."  
Birmingham Archaeological Society. Published O.U.P.
- BRITISH MUSEUM. 1951.  
"Guide to the Antiquities of Roman Britain."
- BOON G. C. 1967.  
"Roman Glass in Wales."  
Annales du 4<sup>e</sup> Congrès International d' Étude Historique du Verre.
- BULMER W. 1955.  
"Roman Glass Vessels in the Corstopitum Museum, Corbridge."  
AA. 4th Series Vol. XXXIII.

- BUSHE-FOX J. P. 1913.  
"Excavations on the Site of the Roman Town  
at Wroxeter, Shropshire, in 1912."  
RSAL No. I.
- BUSHE-FOX J. P. 1914.  
"Wroxeter" (2).  
RSAL No. II.
- BUSHE-FOX J. P. 1916.  
"Wroxeter" (3).  
RSAL No. IV.
- BUSHE-FOX J. P. 1926.  
"First Report on the Excavation of the Roman  
Fort at Richborough, Kent."  
RSAL No. VI.
- BUSHE-FOX J. P. 1928.  
"Richborough" (2).  
RSAL No. VII.
- BUSHE-FOX J. P. 1932.  
"Richborough" (3).  
RSAL No. X.
- BUSHE-FOX J. P. 1949.  
"Richborough" (4).  
RSAL No. XVI.
- CHARLESWORTH D. 1959 (a).  
"Roman Glass in North Britain."  
AA. 4th Series. Vol. XXXVII.
- CHARLESWORTH D. 1959 (b)  
"Roman Glass in Tullie House Museum."  
CW. New Series. Vol. LIX.

CHARLESWORTH D.

1965.

"Glass from Pompeii in Alnwick Castle Museum."

AA. 4th Series. Vol. XVIII.

CHESTERS MUSEUM.

1907.

"An Account of the Roman Antiquities Preserved  
in the Museum at Chesters, Northumberland."

CURLE J.

1911.

"A Roman Frontier Post and its People. The  
Fort of Newstead in the Parish of Melrose."

Published Glasgow University Press.

CURLE J.

1931-32.

"An Inventory of Objects of Roman and Provincial  
Roman Origin Found on Sites in Scotland not  
Definitely Associated with Roman Constructions."

PSAS. Vol. LXVI (6th Series Vol. VI)

FREMERSDORF F.

1958.

"Romisches Buntglas in Köln."

Published Verlag der Lowe Köln.

GAGE J.

1832.

"Plan of Barrows Called the Bartlow Hills in the  
Parish of Ashden, in Essex, with an Account of  
Roman Sepulchral Relics Recently Discovered in  
the Lesser Barrows."

Archaeologia. Vol. 25.

GAGE J.

1835.

"The Discovery of Roman Sepulchral Relics in one  
of the Greater Barrows at Bartlow in the Parish  
of Ashden, in Essex."

Archaeologia. Vol. 26, 1836.

- HARDEN D. B. 1933  
"Ancient Glass."  
Antiquity. Vol. VII.
- HARDEN D. B. 1936.  
"Roman Glass from Karanis."  
Published University of Michigan Press.
- HARDEN D. B. 1947.  
"The Glass."  
In "Camulodunum". (Ed. Hawkes and Hull).  
RSAL. No. XIV.
- HARDEN D. B. 1962.  
"Glass in Roman York."  
In "Eburacum". Royal Commission on Historical  
Monuments.
- HARDEN D. B. 1968.  
"Ancient Glass I: Pre-Roman."  
Arch. J. Vol. 125.
- HARDEN D. B. 1969.  
"Ancient Glass 2: Roman."  
Arch. J. Vol. 126.
- BARRINGTON HAYNES E. 1948.  
"Glass Through the Ages."  
Published Penguin.
- ISINGS C. 1957.  
"Roman Glass from Dated Finds."  
Published J.B. Wolters, Groningen, Djakarta.
- KILBRIDE-JONES H.E. 1937-8.  
"Glass Armlets in Britain."  
PSAS. VOL. LXXII (Sixth Series Vol. XII).

- MAY T. 1904.  
"Warrington's Roman Remains."  
Published Mackie and Co., Ltd.
- MORGAN W. L. 1907.  
"Report on Excavations at Coelbren."  
Archaeologia Cambrensis. 6th Series.  
Vol. VII, Part II.
- MORIN-JEAN (abbreviated to M.J. throughout the text.)  
1913.  
"La Verrerie en Gaule sous l' Empire Romain."  
Librairie Renouard - Ed. H. Laurens, Paris.
- NEUBURG F. 1949.  
"Glass in Antiquity" (trans. Charleston R.J.)  
Published Art Trade Press, London.
- RICHMOND I. 1955.  
"Roman Britain."  
Published Penguin.
- ROBERTSON A. 1970.  
"Roman Finds from Non-Roman Sites in Scotland."  
Britannia. Vol. 1.
- STEVENSON R.B.K. 1954-56.  
"Native Bangles and Roman Glass."  
PSAS. Vol. LXXXVIII.
- THORPE W.A. 1936.  
"The Prelude to European Cut Glass."  
Journal of the Society of Glass Technology.
- THORPE W.A. 1945.  
"English Glass."  
Published A. and C. Black, London.

PREFACE.

Glass will never be as valuable a type of archaeological material as pottery, partly because it is found less frequently during excavations, and also because there are fewer differences to be seen in the glass vessels of different periods. It is, however, an interesting material in itself, and glass vessels can provide some insight into the social and economic standing of those who lived on ancient sites. This supplements information obtained by other methods and from other types of material.

A particularly important work of reference for excavators of Roman sites in the north of Britain is Mr. J. P. Gillam's "Types of Roman Coarse Pottery in North Britain." This work has been the inspiration for the series of types of glass vessels in Section III of this thesis. To produce the series, I have examined all the glassware found on the Roman site at Corstopitum, Corbridge; I have classified the vessels typologically and considered the dating evidence from the historical context in which the vessels were found; I have then considered glassware from other sites in North Britain and a few important sites elsewhere.

In this typological classification I have attempted to divide the basic categories only when there are significant differences in the shape or the decoration of the vessel. I found it convenient, in some cases, however, when considering a large number of vessels of a basic type but with differing details, to classify them as separate types rather than sub-divisions of a single type. I have restricted my work to the common types of vessels in North Britain, and this factor will explain why notable glass vessels which are represented on only one site in North Britain have been omitted. Further I do not consider that a single specimen justifies its inclusion as a type.

To illustrate the types of vessels I have relied largely upon diagrams from published works, although some figures are my original drawings of the vessels themselves. Where possible the illustrated examples are of vessels found in North Britain, although in some cases it has been necessary to reproduce drawings of the appropriate type from South Britain or the Continent.

The two introductory sections of this thesis are an attempt to collect and summarise information about ancient glass, and Roman glass in particular, from several different sources. The first section considers the history and technology of ancient glass and the second section is concerned specifically with Roman glass. In Chapter 3 I have examined the evidence for glass making in Roman Britain, something which I understand has not been collected together before. In Chapters 4 and 5 I have described the important sites which have yielded glass and the archaeological method used in the production of the series of types in Section III.

Since this work is largely breaking new ground, I submit it here in the hope that it will be a useful work of reference, and, more important, that it will inspire further research into Roman glass in North Britain until the full potential of Roman glass as an archaeological material is recognised.

\* \* \* \* \*

SECTION I.

THE HISTORY AND TECHNOLOGY

of

ANCIENT GLASS

## CHAPTER 1.

### The Origin and History of the Glass Industry.

The tradition concerning the discovery of glass is recorded by Pliny:

"..... fama est adpulsa nave mercatorum nitri,  
cum sparsi per litus epulas pararent nec esset  
cortinis attollendis lapidum occasio, glaebas  
nitri e nave subdidisse, quibus accensis,  
permixta harena litoris, tralucentes novi  
liquoris fluxisse rivos, et hanc fuisse  
originem vitri."

( N.H. 1.36,191. )

According to this legend a ship carrying saltpetre merchants, possibly Phoenicians, came to shore, and the men scattered along the beach to prepare a meal. Since there were no stones on which they could support their kettles they used blocks of saltpetre from the ship for this purpose. When these had become heated in the fire the saltpetre fused with the sand on the beach and a stream of glass flowed from the fire. This is the tradition of how the first glass was produced but scientists now agree that the production of glass in this way is technically impossible.

Glass probably originated when, in the course of the manufacture of early pottery, a frit, which hardened on cooling, was discovered on the surface. This aroused the interest of the workers, who gradually discovered how to produce it in a controlled fashion, and they developed it into a glaze on pottery which gave vessels a smooth, watertight surface. They became skilful at producing different colours and textures of glaze, but it was nearly a thousand years before they learned how to collect the glaze as a separate new material, glass.

Nearly all scholars now accept that glass as a separate substance was first made in Mesopotamia. The earliest, fairly certain, evidence which we have for glass making anywhere in the world was discovered at Abu Shahrain, ancient Eridu, in Mesopotamia. A lump of dark blue glass, which is generally thought to be an ingot, which would be remelted to make glass objects, was found in a layer which must be dated at least as early as 2000 B.C. The earliest glass objects to be produced were beads which must have been very rare and costly when they were first made in the late third millenium B.C.

Once beads had been produced in glass, the next stage was to produce vessels in this new material. A further four centuries, however, elapsed, before the technique of building molten glass around a core was developed and the first vessels were produced. Fragments of some of the earliest glass vessels were discovered during excavations at Tel Atchana in the Near East in a level dating around the end of the sixteenth century B.C. The site at Nuzu also yielded fragments of glass vessels which could be dated to the early fifteenth century B.C. At this time the glass industry appears to have been centred in the East in North Syria and Mesopotamia.

Its spread to Egypt was brought about partly as a result of the increasing military strength of Egypt, and the activities of Pharaoh Tuthmosis III, who expanded the Empire to include Syria up to the borders of Mesopotamia. This gave the Eastern glass industry the opportunity to send workers into Egypt to open glasshouses there, which would produce fine and costly glass vessels for the Egyptian market. Some very early examples of these Egyptian products were three vases found with the cartouche of Pharaoh Tuthmosis III. It is interesting to note that these specimens are very far removed from the crude type

2a

PLATE I.



Early Egyptian Glass Vessels.

18th Dynasty - 15th Century B.C.

(Guilbenkian Museum, Durham.)

of glass vessel which one might expect as the first products of glass makers who were discovering how to work, and experimenting with the new material, and they are clearly the product of a rapidly developing industry. They are very fine vessels, in good quality glass, and they show a high standard of workmanship.

For over two centuries the glass industry developed in Syria and Egypt and excavations by Petrie at El-Amarna in Egypt have produced interesting remains of glass working in the area of Upper Egypt, near to the new capital, some 200 miles away from the Delta area where the industry was first introduced into Egypt. Between 1350 B.C. and 1250 B.C. the industry spread throughout much of the Mediterranean area. However, the events which brought to an end the Bronze Age cultures in that area, around 1200 B.C., also had an effect upon the glass industry, which, it appears, virtually died out after this time until about the ninth century B.C. A few vessels dating from the interim period have been found, but these are very few in comparison to the numbers which were made either during the earlier period of expansion or in the later centuries.

The Eastern glass industry became active again in the late ninth century B.C. and during the eighth and seventh centuries B.C. many glass vessels were produced. The most usual method of production was to build the glass around a core, although occasionally other methods were used. (For details of techniques see Chapter 2.) Most of the vessels produced during this period were very attractive, for they were usually made of glass of different colours which were placed around the core to give very decorative designs. This does not, however, mean that monochrome vessels were unknown. There is evidence for vessels being made in clear glass, usually with a greenish tinge. Almost colourless and blue glass specimens have also been found. The industry changed

little during the next few centuries, although techniques were perfected and slight changes were made in the shapes of the vessels produced. In the fifth and fourth centuries B.C. pale green or colourless glass became more popular and the technique of decorating vessels by cutting designs in the glass was developed. A few examples of cut glass dating from the fourth century B.C. were found at Ephesus, and a number of parallels have been discovered on other Eastern sites.

There is some evidence for the introduction of glass-making into Northern Italy during this period. Here a number of glass vessels dating from as early as the eighth century B.C. have been found. They were mostly of monochrome glass in shades of blue, green, brown and yellow. These vessels are obviously important in relation to the history of the glass industry but at present the exact relationship between the Italian glass and that from the Eastern glasshouses is uncertain. It is to be hoped that further research into the subject will clarify this.

The centuries immediately preceding the Christian era saw no new techniques in the production of glass vessels, and there appears to have been little change in the types of glassware produced in Mesopotamia. In Syria, however, there was a noticeable change. The earliest types of glass bowls were produced here, made of monochrome glass in a number of tints including pale green, amber, blue and wine-coloured. There were also some specimens in almost colourless glass. These bowls, which were of different shapes, were polished all over and they often had two or more concentric grooves near the rim. Glass bowls became increasingly popular and as the industry spread they were widely produced. These early types were gradually developed until they became the pillar-moulded bowls which were so popular in the early Roman period.

The revival of the Egyptian glass industry probably occurred

in the early third century B.C. in the city of Alexandria. Large numbers of workers from the Eastern glasshouses moved to this newly-founded city, and established workshops where fine glass vessels were made. Unfortunately very few of these early Alexandrian products have been discovered, although their similarity to the vessels which were being produced during the same period in Syria may explain why some specimens have been overlooked.

The Alexandrian glass workshops became increasingly famous for the fine quality glass which they produced, including elaborate mosaic wares and sandwich gold-glass, which was formed out of two layers of glass with a decorative gold leaf decoration on the outside of the inner layer. Many references to these Egyptian luxury glass wares can be found in the writings of ancient authors including Cicero and Strabo.

By the closing years of the first century B.C. the glass industry was on the point of a radical change, and it is particularly relevant, before considering this change and the effect which it had on the industry, to summarise the extent of the industry and the distribution of the glassmaking centres before the change occurred. There appear to have been two main glass-producing areas: Egypt, centred around Alexandria, and Syria, on the coast around Phoenicia. From these areas workers had taken the art of glass making throughout much of the Aegean and Mediterranean areas including Greece, South Russia and the Caucasus, and later Italy.

The invention of glass-blowing was undoubtedly the most significant event in the history of the glass industry. It meant that more varied shapes of vessels in finer glass could be produced much more quickly and with much less effort than before. The discovery of this new technique occurred during the last fifty years B.C., a fact which can be verified by early examples of blown glass found on excavations. Much less certain is the place where the discovery was made. Contemporary

writers give no definite information about how or where the invention took place, so it is necessary to consider the archaeological evidence for the place of discovery. Scholars now believe that the technique was developed in Syria, partly because the early method used by the Syrian glass workers to produce bowls would be most likely to develop into the new technique of glass blowing, and also because at a very early date in the first century A.D. Syria became an important centre where mould-blown vessels were produced, whilst for some years at least the Egyptian glasshouses tended to continue to make vessels by the older methods. Gradually, however, the older processes were abandoned, and by the end of the first century A.D. the vast majority of glass vessels, if not all, were made by blowing, either freely or into a mould. (For details of techniques see Chapter 2.)

Our knowledge of the development and spread of the glass industry after the invention of glass-blowing is somewhat confused. It is often the subject of inspired guesswork rather than reasoned fact, since there is a shortage of definite evidence. Much more work needs to be done on this topic, but it must suffice here to make an attempt to state the most likely development as it can be deduced from the writings of scholars who have studied the subject.

During the first century A.D. the Syrian and Egyptian sides of the glass industry continued to develop independently, although commercial factors obviously affected the types of vessels produced to some extent. The Syrian glass makers did not concern themselves unduly with the quality of the glass metal which they produced; they aimed rather at making fairly inexpensive, household vessels for the general market. These were blown vessels in pale green glass. The more elaborate wares which they produced tended to represent natural objects including shells and bunches of grapes and other fruits. There were also some vessels which resembled human

heads. The Egyptian workers, meanwhile, concentrated more on the colour of the glass which they made and they became particularly skilful at producing elaborate variegated mosaic and millefiori vessels. They also produced some domestic wares for the home market, but clearly they specialised in making elaborate and expensive glass both for the wealthy Egyptians and for export to those in high social position throughout much of the Mediterranean and particularly in Rome. It was in Alexandria that the technique of cutting and polishing decorative designs on glass was developed, and very attractive vessels were produced by this method. In some cases cutting was done on layers of glass in a cameo technique, and probably the most famous example of a vessel produced by this method is the Portland Vase.

It may be assumed that it was from Alexandria that the workers who first produced glass vessels in Rome, migrated, for it was the fine coloured wares, typical of the Egyptian industry, which were popular in Rome. In general, however, it may be assumed that the Egyptian glass industry preferred to export its finished products to the Empire, rather than to send craftsmen to open glasshouses further afield. The Syrian approach, however, was different. The leaders of the industry there realised the difficulties involved in transporting expensive and fragile glass from their factories in the Eastern Mediterranean to the markets on the Continent, and within a few years of the introduction of glass-blowing, workers were being sent out from Syria to establish glasshouses.

The first migration of Syrian glass workers was through the Aegean area and into Northern Italy, where glasshouses were established fairly extensively. From here the industry fanned outwards to the West and North into Gaul and Central Europe. This spread occurred rapidly during the first century A.D. and glass was produced extensively. It

must be stressed, however, that the vessels produced in these new centres were basically the same as those made in Syria, and for some time after the glasshouses had been founded, Syrian workers migrated to the new factories to provide the skilled labour, and to teach the local people the techniques by which glass vessels were made.

One important area to which the glass industry spread during the first century A.D. was the Rhineland, and in particular to the city of Cologne, the senior town in Roman Germany. Here the glass industry, along with many others, flourished and the area became very prosperous and exported goods widely. The Rhineland was a good location for the production of glass because there was a large supply of glass sand readily available, and this was particularly important because its chemical composition was such that glass produced from it was of good quality and almost colourless. The industry flourished in this area in the late first and particularly during the second century, although it remained important throughout the Roman period.

In the later centuries of the Roman period the different centres of the glass industry tended to develop independently and the types of vessels produced varied from those produced in the East. At this point it is clear that most of the glass to reach Britain, if not all, came from the Continent and economic factors would support this. Some of the early vessels to reach Britain must have been made in Egypt or Syria, but in later centuries, when forms were being produced extensively, Continental origin is much more probable.

## CHAPTER 2.

### The Composition and Manufacture of Glass

#### Vessels in Pre-Roman and Roman Times

##### The Composition of Glass

Glass is a compound substance, which is obtained by the fusion of silica with an alkali. The ancient glasshouses obtained their silica from quartz-sand which was available locally, or from quartz, siliceous pebbles and flints which had been reduced to powder by heating and then sprinkling with water. For an alkali the ancient glass makers used one of two different agents. The majority, and particularly those who worked in glasshouses which were situated near to the sea, obtained a sodium (soda) compound by burning sea weed, whilst the alkali for inland glasshouses was a potassium (potash) compound, obtained from wood-ash. In all glass the proportion of silica is dominant and the maximum and minimum figures for the silica content are 75 per cent. and 60 per cent. Analyses have revealed that Roman glass contained  $71\frac{1}{2}$  per cent. silica and  $16\frac{1}{2}$  per cent. soda.

The use of the various alkalis meant that there were two distinct types of glass which were basically different in character. Soda glass had a lower melting point and it remained longer in a plastic condition, which meant that it could be moulded, blown thin or drawn out into shape easily. Potash glass hardened more quickly at a higher temperature. Consequently it could not be made into elaborately shaped vessels, although it was much more suitable for cutting and engraving than soda glass.

##### The Production of Glass.

Glass is produced when the necessary agents are mixed together

and heated to an intense heat in a furnace. This causes them to fuse and molten glass is formed.

An important factor in this production of glass is the availability of a good supply of fuel for the glass furnaces. The ancient glass workers used wood as fuel and Pliny stated that the best type was light, dry wood which would burn quickly giving an intense heat. Both tamarisk and papyrus were considered particularly suitable for this purpose, but it is certain that the ancient glass workers also used other woods, according to availability, to heat the furnaces in which the "raw glass" was produced.

#### The Colouring of Ancient Glass

All glass sands contain some impurities, chiefly metal oxides, which have the effect of colouring the glass. The ancient glass workers realised that sands from different areas produced different colours of glass, and it was only a short step from that to the deliberate controlling of colours. It is doubtful whether the glass workers had any idea of the chemistry involved in the production of any given colour, but it is clear that by experimenting with mixtures of sands from different areas, many varieties of different colours of glass were produced, including shades of blue, green, red, yellow and brown.

At one time the glass industry aimed at producing vessels which resembled semi-precious stones in colour and texture. To obtain the right colour the glass workers ground down quantities of these stones and added the powder to the glass-batch. This process was particularly successful using lazulite and malachite, which made the glass so produced opaque blue and opaque green.

At first nearly all glass was opaque, but at a later stage in its

development, transparent glass was produced. The first colours of this new type of glass were brown, violet and blue. The colouring of transparent glass was a specialised work involving many years' experience in mixing different sands and metal compounds, and the glass workers in Alexandria were expert in this field.

At the time of the invention of glass-blowing there arose a demand for thin-walled, colourless vessels. The production of a colourless, pure metal was very difficult and much time and effort were spent before a glass which was almost colourless was produced. Many experiments were carried out with sands from different areas before a sand was discovered which contained a substance, now known as glass soap, which had the effect of removing the colour from the glass metal. It is now known that the agent was probably Manganese, although the proportion of this in the glass must be carefully regulated. Even the so called "colourless" glass was not entirely free from impurities and this can best be seen on broken edges where a green, yellow or purple tinge is often detectable.

#### Mosaic and Millefiori Glass

Mosaic glass originated in Alexandria. It was admired and greatly prized and it was particularly in demand in Rome. This highly decorative glass was made by arranging small pieces of glass of varying colours, shapes and sizes, side by side either haphazardly or in some definite pattern. Unlike true mosaic work, in which the small pieces of stone or other material were fixed together by means of cement or some other adhesive, these glass fragments were spread on a clay base and heated in a furnace in such a way that their edges ran together and fused. By this means the pattern was made to penetrate the whole thickness of the material and it was equally visible on either face. The plaques made in this way were finished by grinding and polishing the surfaces. They were usually tetragonal, rectangular or oval,

and whilst the small ones were used for ornaments in rings and brooches, the large ones were reheated and shaped to make bowls and dishes.

Another method of making mosaic glass vessels involved the small coloured glass fragments being placed in a hollowed clay mould, which was then placed in a furnace to enable the glass to fuse. The fine smooth surface was obtained after the vessel had cooled by careful grinding and polishing.

A much later technique of making mosaic glass was developed after the invention of glass blowing. This involved plaques and disks of coloured glass being applied to the surface of a bubble of colourless glass, as close to each other as possible. This was worked by the craftsman until the colourless glass fused with coloured fragments, to form one homogeneous mass, which could then be blown and moulded into a vessel of any required shape.

Millefiori glass, a development of mosaic glass, was produced in Egypt and also by Alexandrian workers in Rome itself. Glass rods of different colours were arranged in bundles in such a way that the cross section made a pattern. These bundles were heated and they were then drawn out thin, which caused the pattern in the cross-section to become smaller and more delicate. These rods were cut into small round or oval plaques, which were set out side by side and fused together in the same way as ordinary mosaic glass. The resulting large plaques were pressed while still ductile into moulds to produce vessels.

The true "Mille Fiori" (thousand flowers) glass was produced when rods of one colour were given one or more castings with different coloured glass. They were then marvered while still ductile on a corrugated slab, producing a rod which could be cut into star-shaped plaques. If these processes were performed with a tube in the centre instead of a solid rod, the resulting plaques were flower shaped. When multi-coloured flowers of

various shapes and sizes were fused together, the resulting vessel resembled a bed of flowers.

#### Early Methods of Making Glass Vessels.

In the early years of the glass industry vessels were produced by four different methods. The most common of these in the earliest period involved building molten glass on a core. This core was made either of clay or of a linen bag filled with sand. It was placed around a metal rod. The whole was dipped into a crucible of molten glass in such a way that it picked up enough glass to form the neck and the body of a vessel. Alternatively the glass was drawn out and wound on to the core. The outside of the vessel so made was then finished on a smooth slab or marver. Later the handle and the footring were added and the core and rod were removed. The rim was finally trailed on and fashioned.

Another method of producing vessels was to build them up from sections of glass rods on a mould. The rods were built around the mould and an outer mould was then added to keep the sections together whilst they were heated and allowed to fuse. After the vessels had cooled the moulds were removed and the outside, and if possible the inside surfaces also, were polished.

Glass vessels were also cut from raw blocks of glass. Quartz and flint were used for polishing and finishing vessels which had been produced in other ways, but it was discovered that they could also be used to shape vessels from raw lumps of glass which had not previously been cast.

The method which became most popular in the later period was the casting of vessels in closed or open moulds. This casting was done either by pouring molten glass into the mould and manipulating it into the correct shape, or by fusing powdered glass in situ between the two parts of a closed mould.

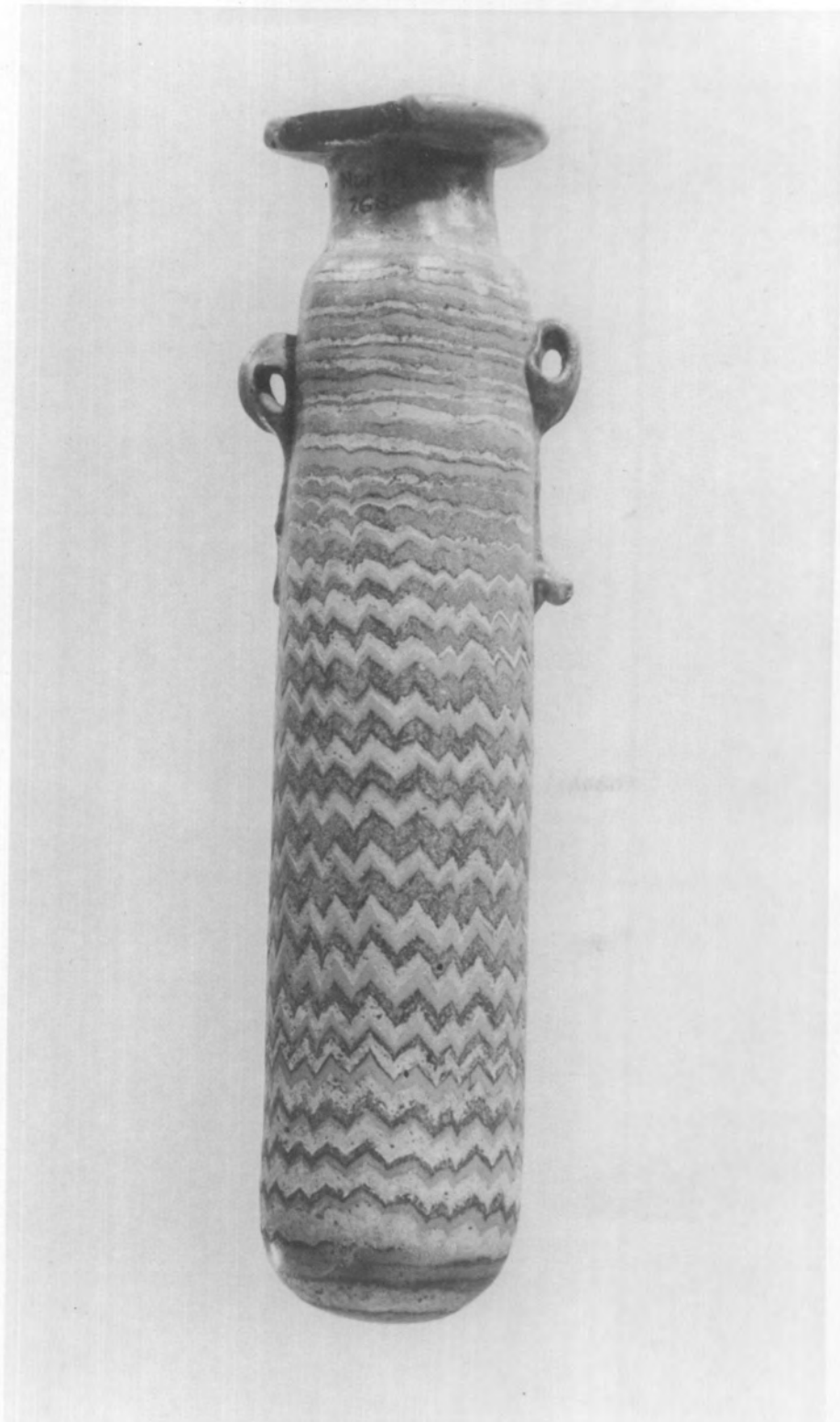

Unguentarium Produced by the  
Sand Core Process.

Egyptian 26th Dynasty.

(Guilbenkian Museum, Durham.)

Glass-Blowing.

The invention of glass-blowing was the most important advance in the history of glass making, and the techniques of blowing glass vessels have changed little since Roman times. Some vessels were produced in moulds into which the glass was blown, whilst others were free-blown. It is still possible to see workers in Venice and glass-producing centres elsewhere making vessels by this ancient method. A pot of molten glass is kept in a furnace and the worker takes from this a gob of glass on an iron tube called a blow-pipe. He slightly inflates this gob and manipulates it into shape by swinging it, rolling it on a flat surface (marvering), or working it with tools. The gob is then inflated and the vessel tooled into its final shape. A solid rod is then placed on the base of the vessel which is removed from the blow pipe and the neck and rim are finished by tooling. The finished vessel is then placed in an oven in which it is slowly cooled.

Ever since the technique was developed, the blowing of molten glass into moulds has been the most common method of producing glass vessels. In the modern industry this blowing is done mechanically but in ancient times the glass workers actually inflated the glass into the moulds which were removed from the complete vessels after the glass had cooled.

The vessels produced by blowing had three main advantages over the earlier mould-made types. Firstly, they could be produced much more quickly and with much less effort. Secondly, they could be manufactured in almost any shape, and consequently household vessels were now available in glass which had previously been made in other materials. Thirdly, the vessels made by blowing were thinner and more transparent than those cast in moulds, and consequently they were more acceptable for table ware.

SECTION II

ROMAN GLASS

### CHAPTER 3.

#### Evidence for Glass Making in Roman Britain

Although it would be generally agreed that the vast majority of the Roman glass found in Britain was imported from the great glass-producing centres on the Continent, there is some evidence for glass production during the Roman period in Britain itself. Whilst much more research into this is necessary, the topic is worthy of discussion here.

The most complete evidence for glass making in Roman Britain comes from Wilderspool and Stockton Heath, near Warrington. It is particularly interesting that evidence for an ancient glass industry should be found in this area, so close to one of the centres of modern glass production, St. Helens. The main reason for this could be that the sand from Wilderspool is particularly suitable for glass making, and it provided the Roman glass workers, and still provides the modern industry, with one of the basic raw materials.

During excavations in the opening years of this century, evidence was found of at least five glass makers' workshops at Wilderspool. They each had furnaces in them and there was further evidence for glass making in the form of slag and lumps of waste glass within the workshop area. The furnaces were rather similar to pottery kilns and it is clear that they were built in such a way that a very great amount of heat would be produced. The base of one of them was an oblong platform of dense clay, enclosing an oval cavity from which projected a stoke-hole. There was a hole at the back for a flue, or for charging and discharging the contents and for the removal of ashes. Over the furnace was built a form of arched oven. The stoke-holes of these furnaces were lined with reddened clay, whilst the interiors

were calcined to some considerable depth by the intense heat. This description indicates the basic design of the furnaces, although there were individual minor differences and variations in the plans.

Around the furnaces there were several fragments of "massae" (crude half-made glass), including pieces of twisted glass rods; many bits of hollow glass vessels of various shapes; and lumps of sandiver, or scum, which was part of the waste matter which remained in the glass pots after the pure glass had been removed. Although no pieces of the glass crucibles were found during these excavations, there is a record of a vessel which might have been used for this purpose having been found in the sand pits at Wilderspool. A fragment was found of "a large crucible of buff-coloured material, having on one side (part of the interior of the crucible) a thin deposit of two colours, lapis lazuli and golden yellow." (May T. 1904)

The types of glass vessels produced in these workshops were very varied and it appears that the people who worked in them were very competent. The evidence of the crucible described proves that coloured glass was produced and this is substantiated by the discovery of lumps of unfinished glass of green, blue and white.

Amongst the fragments of vessels which were found at or near the glass workshops at Wilderspool were three small pieces of facet-cut beakers. One of these is particularly important since it may indicate that these vessels were made in the nearby glass works. On this particular fragment there are two carefully polished and finished-off facets, whilst the third is only roughed out, and obviously unfinished. This suggests that the vessel broke during the polishing operation, and that it was rejected at the works. This would appear to be a strong argument in favour of the vessel's having been made on the spot, but

the point must be made that an ancient Roman legal code made special reference to glass cutters and polishers and their legal position in the event of their breaking the vessel which they were finishing. The law stated that if the cutter carelessly broke a vessel, then he was responsible and had to stand any financial loss, but if the vessel broke in the cutting because there was a flaw in the metal then the maker of the vessel was liable to pay compensation. This law, which was clearly made to protect the glass cutters, suggests that the finishing of these fine, cut-glass, polished wares did not take place in the factory where the glass was produced, but rather in separate shops and works, from which they were sold to the public. It is possible that the workers at Wilderspool did not in fact make these fine, good-quality vessels, but that they had the facilities to carry out the decorating and polishing of vessels which they had imported from elsewhere, for distribution to the British market.

Another site which has produced possible evidence for glass-making in Roman times is Caistor-by-Norwich. Excavations here yielded a horseshoe-shaped furnace and two rectangular structures placed back to back, which it is thought were ovens. The furnace which measured 4 feet 3 inches (1.25 m.) by 4 feet (1.20 m.) had a flue 1 foot 5 inches (42 cms.) long and 10 inches (25 cms.) wide, which opened into an oval chamber 1 foot 3 inches (37 cms.) in diameter. As this structure was in a ruined condition it was impossible to determine full details about it, although there was some evidence for what appeared to be a subsidiary flue going into the main one. This furnace showed definite signs that it had been subjected to intense heat over a long period of time, and ashes, charcoal and lumps of slag-like material, probably from the collapsed dome of the furnace, were found inside the

structure. Nothing was found, however, which would indicate the function of the furnace.

The structural details of one of the two rectangular ovens could be recognised almost entirely from the remains which have been recovered. It was a rectangular enclosure, measuring internally 4 feet 10 inches (1.45 m.) by 2 feet (60 cms.) The exact height of the oven is not known, but it is probable that it was built so that the top was flush with ground level. The sides, except the one which joined on to the second oven, were made of blocks of clay,  $2\frac{1}{2}$  inches (6 cms.) thick, which were moulded and placed in position whilst they were still soft. These were backed with rubble mixed with clay and then with a layer of broken tiles. The bottom of the oven consisted of a slightly concave clay floor 7 inches (17 cms.) thick, made up of three layers interspersed with ashes. Immediately above the floor was a layer of sandy ash containing calcined flints and fragments of fused and splintered glass. Above this was a layer of burnt clay which is clearly the remains of the collapsed upper floor of the oven. In its original form this floor was about  $2\frac{1}{4}$  inches to  $2\frac{3}{4}$  inches (6 - 7 cms.) thick, and its upper edge was  $2\frac{1}{2}$  inches to 3 inches (6.2 - 7.5 cms.) below the top of the oven. Just above the original upper floor level was a band of fused glass about 1 inch (2.4 cms.) wide sticking to the sides of the oven. In one angle of the structure was a small cavity, about 3 inches (7.5 cms.) in diameter, which slanted downwards into the space below the upper floor.

Much less remains of the more northerly of the two rectangular ovens, but it appears that this was rather different from that previously described. The walls were of blackened tiles set on edge, whilst bonding tiles were laid flat to produce a floor about 3 inches (7.5 cms.) above that of the adjacent oven. There is strong

evidence that this structure had been exposed to intense heat but its purpose, and function, in relation to the other oven are uncertain.

It will be seen from the foregoing descriptions that the evidence for glass making at Caistor is rather scant, and that what there is is confusing. No evidence of equipment for glass making in the form of tools or crucibles has been found. In only one of the structures described has fused glass been found, and none of the material discovered gives any indication as to what type of glass was being manufactured. The excavator suggests in his report that it was window glass which was being produced, but the method which he suggests the glass makers used appears somewhat unlikely, if not impossible. Clearly the glass was fused in the furnace, which would need to be at a great heat to enable fusion to occur. The furnace found at Caistor closely resembles that found at Wilderspool, and it would be reasonable to assume that both were used for the same purpose. The rectangular structures, it is suggested, were annealing ovens in which the glass was cooled. Heat was produced in them by means of a fire in the lower part of the oven and the heat was increased by means of an artificial blast. When the oven was hot, the molten glass was poured on to the upper floor and it was gradually cooled as the fire burned down. This theory would account for the rim of glass just above the upper floor level, but the exact function of the glass so produced remains a mystery. It was usual for window glass to be produced in some form of mould, for which at Caistor we have no evidence, and if vessels were being produced one would expect more shaped fragments to have been found.

The structures described date from the last period of occupation at Caistor and having outlined the evidence, I conclude by

stating that there may have been, and there probably was, some glass working on the site at Caistor in the fourth century, although much more evidence would be required before one could be more specific about the type of glass which was being produced.

Whenever reference is made to the possible sites for glass making in Roman Britain the three centres which are usually mentioned are Wilderspool and Caistor-by-Norwich, which I have already considered, and Colchester. There is, however, very little definite evidence in the form of structures to suggest that glass was in fact produced at the ancient Belgic capital of Camulodunum, modern Colchester. During excavations in 1933 a quantity of glass fragments were found which Dr. Harden considered were wasters from a glass factory. In his glass report in the volume on Camulodunum Dr. Harden makes reference to the possibility of there having been glass-making in the city, and he states that further details will be given in the second report. Since a second report was never published, we are denied this information, although excavations in 1969 which sought to find the glass kiln in the same area in which the wasters had been found, did yield a small hearth. This may or may not have been connected with the glass industry, and any definite conclusions are impossible. It must therefore suffice to state that in the opinion of at least one specialist, glass was being produced at Colchester, although definite evidence for this is rather scant. Further excavations may yet provide more conclusive evidence.

Excavations during the 1960's at the Romano-British settlement of Manduessedum, modern Mancetter, Warwickshire, have yielded some very interesting evidence of industrial establishments on the outskirts of the town. This site has proved particularly important because it was a centre for the manufacture of pottery, and a large number of pottery

kilns have been found. There is also evidence to indicate that there was some glass working in this industrial complex.

One glass furnace, (and possibly a second), has been found. Like the other structures on the site this furnace has suffered under the plough, but it has been preserved to a depth of 10 inches (25 cms.) Originally it had an internal diameter of slightly less than 2 feet 6 inches (75 cms.), but it was relined and patched at least three times, causing it to become irregular in shape, measuring 1 foot 11 inches (57 cms.) by 1 foot 2 inches (35 cms.) The walls of this furnace were made of clay and, in the latest phase, broken tile was used to provide an even floor. The aperture for the air to enter the furnace was very small, and this, together with the small size of the furnace, suggests that the heat was produced by charcoal which was blown with bellows. There is no evidence for an annealing oven but this may have been attached to the furnace, above ground, and in this case it would have been ploughed away.

When this furnace was discovered a solidified flow of glass was visible on the side of the furnace, around which was a large amount of waste glass. Some of the pieces were warped as a result of heat but most ~~most~~ of the glass was in a very fragmentary condition. This was clearly cullet and it is possible that this furnace was not used to make glass but only to melt cullet in order that it could be reworked. The site has not yielded any glass makers' tools or anything which could have been used as a crucible.

The evidence from Mancetter suggests a very small glass works, possibly a one-man business, which was concerned with the re-using of glass and the blowing of it into new vessels. It can be dated to either the late second or, more likely, the early third century and it continued in use for some time, although it was demolished in Roman times when the

upper part of the lining was pushed in.

Having discussed briefly possible sites of Roman glass kilns in Britain, I find it necessary to sound an important cautionary note. This is probably best made by reference to material from a specific site. Coelbren was excavated by Col. Morgan, who published his report in 1907. After making specific reference to a number of recognisable fragments, he notes in addition : "... many examples of unmoulded glass either direct from the furnace or melted into their present shape as a result of a conflagration in the camp; and of the two classes together, rims and sides joined to unmoulded glass." He then observes: "At first the condition of these remains would give rise to the theory that they were damaged articles from a manufactory on the spot, for which the silica sand could have been procured from Penwylt mountain, about four miles distant. But the idea of a general fire in the camp is more feasible, for the edges of many of the moulded fragments have been blunted by heat subsequent to their original burning, and no remains of either moulds, hearths or crucibles were found."

There is a great danger that whenever glass is found in irregular shapes or distorted by heat, it is regarded as waste glass from a factory, when it is much more likely that the distortion was caused either whilst the vessel was in use or after it had been broken. Col. Morgan realised this, and saw the need for considerably more evidence in the form of a furnace, or equipment necessary for glass making, before he would assume that glass had in fact been produced on the site. It is possible, however, that other excavators did not exercise such caution before drawing conclusions. Hence a number of suggested sites for glass manufacture may not, in fact, have been glass producing centres in Roman times at all.

## CHAPTER 4.

### The Significance of Roman Glass from Sites in Southern Britain and Elsewhere

In his report on the glass found during excavations at Colchester, Dr. D.B.Harden F.S.A. makes the following introductory statement:

"The discoveries at Colchester ..... include a most interesting series of glass fragments covering the years 10 to 65 of the first century A.D., and it has seemed worth while to deal with them in extenso, not only because of their intrinsic merit, but also because most excavation reports pay scant heed to glass fragments, and such a well-documented series is therefore of cardinal importance for glass-historians."

He makes particular reference to a number of Continental sites: Hofheim, Xanten, Weisenau, Haltern and Vindonissa, where the glass found was of particular note, and, with the exception of Hofheim, he comments on the inadequacy of the glass reports.

This is also a weakness of excavation reports of British sites where glass was found. In the vast majority of cases glass objects are included amongst the mass of "small finds" which turn up on any excavation. The writer dealing with these is often not a specialist on glass. Hence only the most remarkable or easily recognisable fragments are discussed, whilst other pieces are neglected because the exact form of the vessel is uncertain or uncommon. Inaccurate recording has led, I suspect, to some distortion of the

picture concerning the types of vessel in regular use and their relative popularity. Even in reports where glass vessels are discussed in detail, very rarely is the historical context in which the finds were made mentioned. This means that it is very difficult, if not impossible, to produce a dated series of types of vessels.

Roman glass from sites on the Continent has been the subject of two important studies. In 1913 Morin-Jean published his book, "La Verrerie en Gaule sous l' Empire Romain". This is an extensive and detailed work in which the author arranges the different forms of vessel typologically, showing the development of the forms from the plain to the more elaborate. He makes the point in his introduction that he is not dealing with the subject historically, although he does make some attempt to distinguish between early and late forms. His survey covers material from France, Belgium and the Rhineland, and although it was published over fifty years ago it remains a very valuable source of reference for material from these areas.

The other important work of reference on Roman glass was published in 1957. This is a book by Dr. Clasina Isings, "Roman Glass from Dated Finds". The author of this book attempts to deal with the different types of glass vessels chronologically, having obtained dates for the vessels by considering the historical context in which they were found. This book considers glass from sites throughout most of Western Europe, and it is a valuable catalogue of this material. It is clear that Dr. Isings was confronted by one very great problem in her chronological survey, namely the virtual impossibility of attributing a close date to the different types of glass vessel. Many forms which developed during the first and early second centuries continued unchanged for three hundred years or longer. This problem of obtaining close dates

for the different forms may also have been aggravated by the inadequate recording of finds, to which reference has already been made.

Of all the places of archaeological interest in the world, the cities of Pompeii and Herculaneum must be amongst the best known. These cities which were buried by the eruption of Vesuvius in A.D.79 are gradually being uncovered and from the evidence produced by these excavations it has been possible to reconstruct a fairly accurate picture of everyday life in a first century Roman city.

During the excavations of the buildings at Pompeii a large number of household utensils were found including several glass vessels. These are of particular significance since they are complete examples of the types of vessel in regular use, and from the contexts in which they were found it is sometimes possible to decide the functions of the vessels. Of particular note is a packing case full of square glass bottles, stacked just as they had been brought into the city. They were almost certainly containers for wine or some other liquid although all trace of the contents of the bottles has been lost.

A number of glass vessels found at Pompeii have been brought to England and they can be seen in museum collections. Thirteen of these are now in Alnwick Castle Museum, Northumberland. The types of vessels represented in this collection include unguentaria, square bottles, large jars with M shaped handles, a square-bodied jar, and bowls, all in natural green glass.

No discussion of Roman glass from the Continent would be complete without reference to the work of Dr. Fritz Fremersdorf, who has made a special study of this material and has published many articles and books on the subject. In his position as Director of the Roman Museum in Cologne he was responsible for the amassing of a vast collection of glass

from German sites, and he was particularly anxious to make a collection of glass produced in the glasshouses on the Rhine. This collection, together with Dr. Fremersdorf's published works, is very important when one is attempting to locate the place of origin of different forms of vessels.

One particular site in Egypt has proved to be particularly rich in glass, and the material from this site has been the subject of a detailed study by Dr. Harden. This site is Karanis (Kom Aushim) in the Fayum, which was investigated by an expedition from the University of Michigan during the five seasons from 1924-29. Excavations here yielded over 150 complete <sup>glass</sup> vessels and thousands of small fragments of many different forms. Unfortunately the stratification of the site was such that it was difficult to attribute a date to any of the finds with any degree of certainty. It appears that buildings were re-occupied, with ground floors serving as cellars in later periods as drifting sand caused the levels of floors and streets to rise. Dating is also made difficult by the fact that in Roman Egypt, as elsewhere in the Empire, at least until the fourth century, glass was a luxury and as such it was carefully preserved and handed down from generation to generation. St. Augustine made an interesting reference to this:

"nonne fragiliores sumus quam si vitrei essemus?  
vitrum enim etsi fragile est, tamen servatum diu  
durat: et invenis calices ab avis et proavis, in  
quibus bibunt nepotes et pronepotes. Tanta  
fragilitas custodita est per annos."

\*\*\* (Sermo XVIII, 7, quoted by Thorpe, 1945)

\*\*\* Trans: Are we not more fragile than if we were made of glass? For glass, although it is fragile, nevertheless lasts for a long time if it is looked after, and you find goblets that once

belonged to grandfathers and great-grandfathers from which grandsons and great-grandsons now drink. Such fragile things are looked after for years.

There is also evidence for glass vessels being re-fashioned and re-used after they had been broken. Realising these difficulties Dr. Harden attempts only a relative dating of the glass ware.

The glass vessels from this site have been divided into fourteen classes, which begin with dishes and plates and pass through different types of bowls and beakers to jars, flasks and bottles of all types, with a concluding miscellany of rods, bracelets, buttons and fragments of window glass. In the introduction to the book Dr. Harden states the wish that his detailed catalogue of material from Karanis would prove of permanent value as a basis for the arrangement of future finds not only from Karanis but also from other Egyptian sites. In fact the value of his work and the significance of the Karanis material far exceeds this original function. It provides a comprehensive study of types of glass vessels which is a valuable source of information and reference for all students of Roman glass.

Mention has already been made of one of the most important sites in Britain which has yielded a considerable quantity of glass, namely the ancient Belgic capital of Camulodunum, modern Colchester. Extensive excavations were carried out in this city over a number of seasons, and the excavators were particularly careful to record the finds in such a way that they could later be placed in their historical context. The site itself showed clear evidence of six phases of occupation during the first century A.D., and it was possible to date these phases fairly closely. This means that fragments of glass can often be dated with some considerable degree of accuracy. Fortunately the significance of the glass from this site was recognised by Dr.

Harden, who reported on it. He produced a detailed record of the types of glass vessels represented.

The earliest glass found at Colchester came from the pre-Conquest phase (Period 1). It consisted of two fragments of delicate, good quality, coloured glass, which substantiates what Strabo wrote, that the Britons imported "glass utensils". It is clear, however, that these were luxury vessels which came into Britain along with pre-Conquest samian and Gallo-Belgic pottery. Only one piece of natural blue-green glass can be definitely dated to before the conquest, although it is possible that a few pieces found in later deposits are rubbish survivals from this earlier phase.

The second phase of occupation of Colchester was contemporary with the Claudian invasion. The material found in this, and in later layers also of Claudian date, indicates a change in the type of glass which was coming into Britain. There appears to have been a gradual increase in the amount of glass being imported, and although much of it was decorated fine ware, the number of natural blue-green glass vessels, of either mould-made or blown types, increased rapidly during this period.

The earliest Claudian level, (Period 2), yielded only one piece of glass, part of a ribbed bowl of amber glass with opaque white marvered threads. In later Claudian levels a greater variety of glass was found, including plain and pillar-moulded bowls in natural green and decorative glass; a rectangular bottle; part of a jug in brown glass; and a decorative wine-coloured flask.

During the fourth phase of occupation at Colchester, from A.D. 49-60, a great change occurred in the quantity and type of glass which was being imported. Most important, a considerably greater

number of stratified pieces were found in this layer, which is indicative of the greatly increased trade in glass from centres on the Continent. Amongst the fragments there was by this time a much greater proportion of natural blue-green glass, although there was also a diversity of fine fabrics, particularly millefiori, and it is interesting that the true mosaic glass was only introduced into Colchester at this period. This phase of occupation also saw the introduction of new types of vessels including perfume bottles, or unguentaria. The glass in this layer included pieces of a bowl with horizontal cuts, unguentaria, flasks, mould-pressed and pillar-moulded bowls in natural and coloured glass.

Colchester phases 5 and 6 marked the end of the fifties, and the reign of Nero. During this time natural blue-green glass occurred most frequently, and of the coloured glass wares dark blue, wine-coloured and yellow glass predominated, whilst fine glass and polychrome wares occurred less frequently. The types of vessel in use during this period included pillar-moulded bowls, flasks, jugs, bowls decorated by wheel-cuts, and of particular note a bowl on which figures of gladiators in combat were moulded.

The picture of the introduction of glass into this country as presented by the evidence from Camulodunum is particularly interesting, and the changes in tastes during the first century A.D. are shown here by the decline of some types and colours of glass in favour of others. It is regrettable that no detailed work like this has been done on glass from a site which was occupied throughout the Roman period, since a study of trends and people's tastes in glass would have been both interesting in itself and valuable evidence for archaeologists in general.

Two other sites which have yielded fairly large quantities of glass are Wroxeter and Richborough, and it is thanks to the accurate and

detailed work of J.P. Bushe-Fox, who carried out the excavations in the opening decades of this century, that the material from these sites provides important dating evidence which can be related to similar materials elsewhere.

At Wroxeter fragments of several different forms of vessel were found including pillar-moulded bowls; square and cylindrical bottles; and jugs, together with a number of pieces of millefiori glass. There were also a number of fragments of facet-cut beakers made of white glass, with oval and diamond shaped facets. One of these was found in a late first to early second century A.D. context, whilst the other could be dated slightly later. Two complete vessels were found, - an unguentarium with a long neck and very short body which could be dated between A.D. 80 and 120, and a bowl with outplayed sides from a dated context of not later than the mid-second century.

The glass from Richborough is also of interest both for the variety of different forms represented and because the vast majority of it came from stratified deposits or rubbish pits. Here, as at Colchester, the material is largely of first century date, increasing our knowledge of the glass of this period but in no way supplementing our scanty information concerning glass in the later centuries of the Roman occupation. The vessels found included flasks and bottles of various shapes and sizes, plain-bodied and pillar-moulded bowls and beakers of various types.

One important problem in any study of glass is the fragmentary nature of the material. It is very rare indeed for a complete glass vessel to be discovered on a settlement site of either a civil or a military nature, and often the fragments are such that it is difficult to assign a definite form to the vessel. When working on these sites the most that can be expected is that it may be possible to reconstruct a glass vessel which had been thrown into a rubbish pit after it had been broken. It is much more

likely that complete glass vessels will be found in cemetery sites, where they were re-used either as cinerary urns or placed in the grave with the body, possibly containing drink or some other requisite for the after life.

Unfortunately very few cemetery sites have been excavated, and some of those which have been examined were opened during the last century by antiquaries who tended to look upon excavation as a form of "treasure hunting." They knew little or nothing of modern excavation technique, and consequently they failed to recognise, and usually destroyed, any dating evidence on the site itself. This does not, however, mean that the reports published by these antiquaries are valueless. They often give accurate descriptions and drawings of the materials found during their excavations and it is usually possible to interpret the information which they provide in the light of modern research.

The barrows at Bartlow Hills in Essex were excavated in 1832-1833 by John Gage. These barrows contained cremation burials and several complete glass vessels were found. Square and cylindrical bottles were found containing ashes, but there were a number of other vessels including a two-handled, rectangular bottle, with a moulded pattern on the base; a flask with a long narrow neck; an unguentarium; a bulbous-bodied flagon; and a decorative cylindrical cup. Unfortunately these vessels were destroyed in a fire in 1847, but drawings which show their exact form remain in the reports of the excavations.

A number of other Roman cemeteries have also yielded glass bottles. In many cases the vessels in question were square bottles which had been re-used as cinerary urns, although occasionally other forms of vessel were also found. These cemetery sites include Mersea Island, Essex; Harpenden, Hertfordshire; Standon, Hertfordshire; Bishopsbourne,

Kent; and Rougham, Suffolk. These are just a few of the many cemetery sites in Britain and it is clear that the study of Roman glass would benefit greatly if more excavations could be carried out in cemeteries where it is to be expected that complete vessels will be found.

## CHAPTER 5.

### The Dating of Roman Glass from Sites in North Britain.

Before considering the Roman Glass from specific sites in Northern Britain, I think it is relevant here to summarise the history of the Roman occupation of the area. It is possible in the light of this to consider the value and significance of glass from particular sites, and how far it is possible to obtain accurate dating evidence by examining the position of the finds in relation to the stratification and history of the site on which they were discovered.

The Roman advance into Britain, since the invasion under Cladius in A.D. 43, had been fairly slow. The hostile tribes of Southern Britain continued a long and effective opposition to the advancing Romans, but gradually and systematically they were overcome and the Romans were able to move northwards without fear of hostilities flaring up in the rear of the advancing army. The military occupation of the northern part of Britain began around A.D. 71 when the newly appointed governor Petillius Cerialis led the 9th Legion into the territory of the Brigantes. He established a fortress at York, and there is some evidence for military activities throughout Brigantia, although it was not until some time later that most of Northern Britain was overcome and absorbed into the Roman Empire. This was the work of the governor Julius Agricola, who in the early 80's advanced northwards, consolidating his victories as he went. In three years he had advanced northwards into Scotland as far as the Tay and he had consolidated his gains, building forts as far north as the Forth-Clyde isthmus with outposts to the north of that line. The exact extent of Agricola's conquests is the subject of much conjecture and discussion at present, but is outside the scope of this survey. It is clear, however, that by the time Agricola was recalled in the winter of

A.D. 84-85 the Romans were in control of all the lowlands of Scotland and the resistance of the Highlands had been broken by the Roman victory at Mons Graupius.

It was not long after Agricola had been recalled that the Romans found it necessary to take a substantial proportion of the British garrison to reinforce the threatened Danube frontier. This meant that troops had to be brought from the most northerly positions to garrison the forts further south, and a number of the most northerly forts were abandoned including Inchtuthil and Fendoch, whilst others, particularly Newstead, were reorganised. This system appears to have been effective for some time although the exact reason for it is not known. It may have been a deliberate attempt to further reduce the garrison in Britain, or it may have been the result of growing opposition from hostile northern tribes. By the early years of the second century, however, the Romans had established a frontier between the Tyne and the Solway, and in the central sector this was marked by the line of the Stanegate.

The accession of the Emperor Hadrian in A.D. 117 meant a change in frontier policy and a definite move to consolidate the Empire behind natural or artificial barriers. Since no natural barrier was available in North Britain, Hadrian's Wall was built across country from the Tyne to the Solway. At intervals of a mile along the Wall were mile-castles in which the troops lived, whilst two turrets were built as look-out towers between each pair of mile-castles. Later, forts were added on the line of the Wall to bring the main body of the troops nearer to where they were required.

The increasing hostility of the tribes to the north of Hadrian's Wall resulted in the Emperor Antoninus Pius ordering the army under Lollius Urbicus to advance into Scotland and to establish a frontier from the Forth to the Clyde. This frontier was a wall made of turf and timber, on the line

of which were a number of fairly small forts and one or two buildings which resemble mile-castles. Whilst the Antonine Wall was in use as a frontier, Hadrian's Wall was thrown open freely and it is likely that the forts on this Wall were evacuated, or left with a small caretaker garrison. By A.D. 158, however, hostilities to the Romans had increased and there is evidence which has been taken to suggest that at least five of the forts on the Antonine Wall were violently destroyed about this time. This resulted in the Romans withdrawing from Scotland, at least temporarily, and a reoccupation of the forts on Hadrian's Wall, which again served as a frontier. The history of the frontier area during the next 25 years is very complex. There appears to have been some movement between the two Walls but at present this is the subject of a great deal of discussion, and it must remain outside the scope of the present summary.

In A.D. 184 the Romans again advanced into Scotland under the governor Ulpius Marcellus, and many of the forts on the Antonine Wall show signs of reoccupation and reconstruction which some archaeologists are disposed to attribute to him. For several years forts on the two Walls were garrisoned simultaneously, it seems, although the mile-castles and turrets on Hadrian's Wall were apparently left unoccupied. There was comparative peace during the next few years in the frontier area, but in A.D. 196 the situation changed. Clodius Albinus, the governor of Britain, made an attempt to seize the imperial throne, and he took the army of Britain to fight for him against Severus. In the absence of most of the occupying forces the northern tribes rose, and there is evidence on a number of sites of violent destruction about this period.

When the civil war in the Empire had ceased, and Severus had become established as Emperor, he ordered the governor of Britain to rebuild the Hadrianic frontier. Soon after the original frontier had been secured

by c. A.D. 205, he himself came to Britain in A.D. 208, and following the Agricolan policy, advanced northwards into Scotland. For a short time a number of the forts in Scotland were reoccupied and a legionary base was established at Carpow on the Tay. There was, however, growing hostility to the Romans, and, on the death of Severus in A.D. 211, Caracalla reversed his policy and finally abandoned most of Scotland, withdrawing to the Hadrianic frontier but leaving some troops in outpost forts to the north of the Wall to maintain peace.

For most of the third century the north of Britain was comparatively peaceful, for the growing threat to the Romans at this time came mainly from attacks on the south of Britain by Saxon pirates. In A.D. 296, however, a similar situation arose to that which had resulted in the destruction of many of the forts at the end of the second century. Civil war had broken out in the Empire, and Allectus had concentrated large numbers of troops in the south of Britain to fight for him against Constantius Chlorus. The removal of the occupying forces gave the opportunity for the hostile Pictish tribes to the north, who by this time had become an organised confederacy, and the Scotti from Northern Ireland, to attack the Roman occupied territory. They advanced across the line of Hadrian's Wall, plundering forts as they went. On this occasion the advance seems to have gone much further than that of A.D. 197, and there is evidence for this attack on a considerable number of sites, not only in the immediate frontier area but also as far south as York and Chester.

Around A.D. 300 rebuilding took place on the orders of Constantius Chlorus, and the army was strengthened in the forts on Hadrian's Wall. These measures appear to have been effective in providing a defence for the frontier for more than sixty years, for the area south of the Wall became increasingly prosperous at this time. The Romans were not popular, however, with the native peoples in the frontier area, and gradually the Picts, Scots

and the invading Saxons joined forces to attack the Romans. The Romans, it appears underestimated the strength of the opposition, and when the attack came in A.D. 367, the forts on the Wall fell and much damage was done. The task of restoring order and reorganising the frontier fell to Count Theodosius, who brought large numbers of troops with him to restore peace. He then began the complex work of reorganisation. The forts on the line of Hadrian's Wall ceased to be purely military in character. They became more like fortified villages or townships, for in this period the inhabitants of the villages outside the forts, which had been destroyed during the revolt, moved into the forts themselves. The new garrisons were given land to cultivate in return for their services and hence the frontier was manned by farmer-soldiers, very far removed from the auxiliaries and legionaries who had patrolled the Wall in the Hadrianic period. Buildings acquired different functions in this period and changes to them are often detectable on sites.

This was the final stage of the Roman occupation of North Britain. The Empire was crumbling and there was a growing threat from the Saxons whose power in Britain gradually increased. The history of the end of the Roman occupation in the early fifth century A.D. remains a subject for speculation by historians and novelists alike, but it must suffice here to state that there is evidence for the abandonment of many of the Roman military structures by the end of the fourth or the early years of the fifth century, although life in the towns continued in the Roman manner for some time until it was superseded by the culture of the invading Anglo-Saxons.

In the light of this history of the North of Britain it is now possible to examine the significance of the stratification of the various sites and to relate this to the glass found.

The material which has served as a basis for the production of the series of types in Section III has been found on the Roman site of Corstopitum, the fort just outside the modern town of Corbridge. This fort, which was in an important strategic position, defending the crossing of the North Tyne by Dere Street, the main route on the East of the country northwards into Scotland, has several different phases of occupation. First occupied at the time of Agricola, the fort remained important during the Flavian period but it was deserted when the Hadrianic frontier was built. At the time of the advance into Scotland the fort again became important strategically and as a supply depot, and it was drastically remodelled about A.D. 161. The fort was destroyed in the rising of about A.D. 197 and repaired around A.D. 205. During the third-century advance into Scotland, the fort was important as a supply depot, but when the Romans finally withdrew from Scotland Corbridge ceased to have any great military significance, and the large store houses which were being built at the depot were never completed. From this time the site became much more civilian in character, occupied by artisans and merchants, and acting as a market and leave-centre for the troops on the Wall. The town, as it had then become, was damaged at the end of the third century and rebuilt under Constantius Chlorus. Its prosperity increased until A.D. 367 when it again fell to the hostile tribes. The rebuilding of the town at the time of the Theodosian reconstruction marked the beginning of the last phase of occupation at Corstopitum, whilst the date of the final evacuation of the site remains a mystery.

The museum on the site at Corstopitum has quite a large amount of glass in its collection. The vast majority of this is fragmentary, although there is one complete vessel, an aryballos (see Type Eleven). This is not, however, the only material from the site. Excavations over many seasons

have yielded large quantities of glass which is not on show in the museum. This is very fragmentary, and in very many cases it is impossible to identify the type of vessel from the shape of the fragments, but some of them can be recognised and classified. For dating purposes the material from recent excavations, where particular attention has been paid to the recording of the stratification of the area in which the glass was found, is of considerably more value than the glass in the museum, most of which has no provenance record at all. In the discussion of the types of vessel in Section III, Corbridge examples of the forms are described first, then parallels from other sites in North Britain and notable examples from elsewhere are referred to. The dating evidence is considered in the light of the different sites on which the form has been found, and a suggested date is given for the type.

Of all the sites in Northern Britain, the one which is the richest in archaeological materials of all kinds is Newstead. This site is also particularly important because it has two distinct phases of occupation, a Flavian and an Antonine. Hence the position in which finds were made in relation to the stratification of the site can give valuable dating evidence. Fortunately the excavator of the site, James Curle, recorded the material in such a way that it could be related back to the context in which it had been found. During his excavations Curle found a considerable number of rubbish pits in the area outside the fort. The material from these was kept separate, and by a comparative study of the pottery with the other material it has been possible to attribute a Flavian or an Antonine date to the majority of the pits, and the finds in them. The dating evidence obtained by the examination of glass from Newstead is used in Section III, along with that from other North British sites, to date the types of vessels.

In the discussion of the glass found during his excavations at Newstead, Curle makes the point that "glass vessels and also window glass were in common use at Newstead throughout the whole period of its occupation by the Romans". He comments on the fragmentary nature of the glass found and he describes the types of vessels represented. These included pieces of pillar-moulded bowls, one of millefiori glass; plain and facet-cut beakers; shallow bowls; flagons; unguentaria; and common square and cylindrical bottles.

In any consideration of material from North Britain, attention must be given to things which have been found in York, the site which served first as the military centre and then as the capital city of the province. Material from here can be considered in two distinct groups. The first dates from the military occupation of the fortress during the late first and the second centuries, and the second from the third and fourth centuries when York was a very prosperous civil as well as military settlement, and twice the imperial residence.

The glass from Roman York is the subject of a paper by Dr. Harden in the Royal Commission on Historical Monuments' volume on the city. Much of the glass discussed is in the Yorkshire Museum, but it is unfortunate that over half of the material has no provenance recorded. In addition, material from other sites has now become mixed with that from York itself, and this is difficult, if not impossible, to distinguish. Despite this, however, the glass is very interesting and of considerable significance. Of particular note are a number of complete vessels in the museum's collection, which came from cemeteries outside the Roman city.

Amongst the first-century material are several fragments of pillar moulded bowls, chiefly of natural green and dark blue glass. Also dating from the earliest occupation of the fortress are two fragments of green and

yellow mosaic glass; part of a flask of a form which occurs frequently in first-century contexts on the Continent; two handles and a base of fine polished cups; and part of a cylindrical cup decorated with moulded figures of gladiators.

The glass typical of the second century is represented at York by a shallow bowl which can be paralleled by similar bowls found at Karanis in Egypt; a fragment of a colourless beaker; and a facet-cut beaker. There are also a number of vessels of this period from cemetery sites. These include one complete bottle containing ashes; fragments of square and cylindrical bottles; a small, complete hexagonal bottle; an ovoid jar with cover; and a number of perfume flasks.

The glass from York dating from the closing years of the second century and the first half of the third century is particularly important because amongst the fragments are examples of some of the best Rhineland glass, such as may have been used in the Severan Court. This was the heyday of the Cologne glasshouses, and the quantity of Cologne glass found at York indicates the extent of its exports. The pieces include some fine bowls, jugs and beakers in crystal glass, some with delicate cut decoration. Of particular interest is a straight-sided bowl with a flat base, the whole covered with geometrical patterns of grooves and facets, and considered to be the finest example of Rhenish crystal found in Britain. (See Type 32). Unfortunately the exact provenance of this vessel is not known, and it is therefore impossible to date it closely.

There is also a large quantity of glass dating from the later third and the fourth centuries, and this is significant because most of the common types of vessel are represented. One reason for this increase in the quantity of glass vessels found may be that the mid-third century saw the change in burial practices from cremation to inhumation, which

meant that grave goods had a better chance of survival, particularly when coffins were used. It is because much of the glass of this period comes from cemetery sites that it is in such a good condition. The quantity and variety of complete vessels is important, because they provide examples of forms which are found in a fragmentary condition elsewhere.

The vessels include pipette-shaped unguentaria; unguentaria with indented sides; a rare form of bottle with a ring-shaped body and "dolphin" handles; wheel-incised beakers; a beaker with indented sides; jugs of fourth-century types; and a number of different forms of flasks and bottles.

The forts on Hadrian's Wall and on the Antonine Wall have yielded small quantities of glass. Most of this is very fragmentary, although the more remarkable pieces are in museums either on the site where they were found or in the larger museums in the North of Britain. This material can be used to supplement our knowledge of types of vessels obtained from elsewhere. It provides additional parallels. Further, dating evidence may be indicated by the presence or absence of certain types of vessel on sites on the Walls. For example, a type which is found at York, Corbridge and in a Flavian context at Newstead, but not on Hadrian's Wall, must have ceased to be produced and distributed by the time of the building of the Wall in the 120's. Similarly, the finding of types of vessels on earlier sites and on the Wall indicates a longer period of production. The dating of material from its presence or absence on the Antonine Wall, however, is less likely to be accurate, since many of the sites show evidence of Roman military activity on or near them at the time of the Agricolan campaigns, and <sup>found</sup> examples/may be survivals from this period.

The civil settlements outside the forts have yielded a little glass, but the most likely sources for obtaining complete glass vessels in the Wall area - the military cemeteries outside the forts - have not been

examined. Here excavators might hope to find glass vessels used either as urns or as part of the grave furnishings. On the subject of cemeteries, mention must be made here of the complete or almost complete glass vessels found in cemeteries at Carlisle, which are now in the Tullie House Museum, Carlisle. Also in this museum is some of the glass from Miss Charlesworth's excavations of the Roman cemetery at Brougham, Westmorland. These excavations have confirmed that glass vessels are to be found in cemeteries in the North of Britain, and that it is worth while to investigate this potential source of evidence.

Glass has been found on some native sites in the North of Britain. Material from Scottish sites has been catalogued very extensively, first by James Curle, who in 1932 published "An Inventory of Objects of Roman and Provincial Roman Origin found on Sites in Scotland not definitely associated with Roman Construction". Recently this work has been supplemented by a paper by Anne Robertson in Britannia I (1970, entitled "Roman Finds from Non-Roman Sites in Scotland". This paper adds to the information collected by Curle all the material found during excavations in the period which has elapsed since he published his paper, including some from unpublished excavations and some surface finds from places where no archaeological excavation has taken place. The types of glass vessels represented on these sites include pillar-moulded bowls; bowls with tubular rims in both coloured and natural tinted glass; fine cups; bottles and flagons, including a very fine complete one from Turrif (see Type 14). As may be expected, most of these types date from the first and second centuries when the Romans were particularly involved in Scotland, although one or two of the vessels found are clearly of a later date.

Unfortunately no comparable study to the paper by Dr. Robertson has been done on material from native sites in the North of England.

Apparently a small amount of glass has been found during the excavations on these sites, but it is insignificant in comparison to the quantity which has been found on military sites. It is doubtful whether a survey of the types of vessels found in native contexts in the North of England, although interesting in itself, would supplement in any way the series of types of vessels produced by examining materials from military sites. Further, the dating of native settlements in Northern England is very difficult. Consequently the presence of types of vessels on particular sites would have little or no significance for dating.

In this chapter I have attempted to show how types of glass vessels can be dated by considering the contexts in which examples have been found. In conclusion I would like to make reference to one site where the presence of a particular type of glass vessel gives an indication as to the date of the site. At Bertha, a site on the River Tay above Perth, no excavation has taken place, but amongst the surface finds from this site are some fragments of pillar-moulded bowls. These bowls can be dated to the first century A.D., and therefore their presence at Bertha indicates Agricolan activity on the site. Unfortunately, however, very few types of glass vessels can be closely dated in this way, and it is very unlikely that glass will ever become a source of dating evidence in any way comparable to pottery.

SECTION III

TYPES OF ROMAN GLASS VESSELS

IN

NORTH BRITAIN

UNGUENTARIA(Types 1-10)

Unguentaria or toilet bottles were amongst the earliest forms of glass vessels. The Egyptians, during the closing four centuries B.C., made elaborate coloured glass unguentaria by placing strips of coloured glass on a clay core, but the invention of glass-blowing meant that a greater variety of forms were produced. The different tastes of the Romans, who preferred natural coloured green or blue glass, resulted in the production of fewer decorative glass vessels. Unguentaria were produced in glasshouses throughout Europe and it appears that they were imported into Britain containing perfumes. A number of these bottles have been found in graves and in the nineteenth century the vessels were given the name "tear bottles" because it was thought that they were used to collect the tears of mourners and then put in the graves. Several different types have been found in North Britain.

\* \* \* \* \*

Type 1. Test Tube Unguentarium.Figure 1. (1) Corbridge (reconstructed).

These vessels resemble the test tubes found in the modern laboratory. They have long, narrow, straight bodies tapering towards the base, which is generally rounded but occasionally flattened. They have no rims at the neck, and we have no indication of how these perfume flasks were closed. The earliest vessels of this type were made in Egypt. They were made on a core and were usually of decorative coloured glass. It may be assumed that in the Roman period the glasshouses on the Continent also produced these perfume flasks by more advanced methods and it is more than likely that the specimens found in Britain are of Continental origin.

Whilst the earliest vessels of this form were made of good quality

45a  
PLATE III.



Unguentaria.

coloured glass, the examples found in Britain are generally made of poor quality, natural tinted glass, often with many bubbles.

At Corbridge an almost complete specimen of an unguentarium of this type was found. It is in pale blue tinted glass. Fragments of two similar vessels have been found at Chesters.

This type of unguentarium was first produced in the ancient glasshouses around 1000 B.C. and it was particularly popular during the fifth and fourth centuries B.C. The plain glass examples which were blown rather than core-made were first produced in the first century. Examples have been found in dateable contexts throughout the Roman period. It appears that they were particularly popular during the first and early second centuries but they were gradually replaced by more elaborate forms.

Suggested date: A.D. 70-180.

See also: M.J. Form 20. Isings Forms 27.

. . . . .

Type 2. Tubular Unguentarium with Constriction.

Figure 1. (2) York.

Unguentaria of this type are basically the same test tube shape as type 1, but there is a definite constriction about half way down the vessel. Some have flattened bases but on most specimens the base is rounded. The walls of these vessels flare out slightly towards the mouth which, as in type 1, usually has no rim, although a few later examples have a heavy rim which is flattened horizontally. They are found throughout the Continent and examples have also been found at Karanis, which would suggest that similar bottles were produced extensively both on the Continent and in Egypt.

The majority were made of natural tinted pale blue or green glass, often of a rather poor quality.

Several examples of this type of unguentarium have been found at York

and the Yorkshire Museum Collection includes a number of complete ones from cemeteries. A similar vessel was found during excavations at Carlisle, and cemeteries at Colchester and Verulamium have also yielded examples.

These unguentaria were probably produced at the same time as vessels of type 1 and therefore the dating would probably be similar. The historical context in which the Colchester and Verulamium specimens were found provides evidence that they were in use in the first and second centuries. On the Continent, dated finds indicate that these vessels were introduced in the early first century and they became increasingly popular in the middle of the century. They remained in use into the second century but they were superseded by more elaborate types.

Suggested date: A.D. 70-140.

See also: Isings Form 8.

.....

Type 3. Unguentarium with Indented Sides.

Figure 1. (3) Brougham.

Vessels of this type vary considerably in size and it is possible that larger examples were used to contain liquids other than perfume. This type is a development of the test tube form in which the body has been slightly inflated, making it broader than the neck, and four depressions have been made in the sides. These vessels are fairly thin walled. The necks are either unfinished or there is a rim. British examples were probably made on the Continent, although the type was also known in the East.

They were usually made of poor quality natural coloured glass.

This type is not represented at Corbridge but one was found during the excavations at Brougham and a number of examples have come from cemeteries in York. Others have been found at Colchester and London, again in cemeteries.

This form is later than types 1 and 2. The suggested date for the

London example is mid-second century, but it appears that the majority can be dated to the fourth century. It may be that whilst the type was first produced in the second century it did not become popular until the fourth. Alternatively, the suggested date for the London example may be inaccurate and the type may be much later, probably first produced towards the end of the third century. I suspect that the latter possibility is the more likely.

Suggested date: A.D. 280-410.

.....

Type 4. Pipette Shaped Unguentarium.

Figure 1. (4) York.

This is a development of the test tube type with an inflated bulge in the centre of the body and a rim at the neck. These vessels are also longer than the test tube unguentaria and they resemble the pipettes used in the modern laboratory. They are found frequently on sites in Europe and in Syria and it appears that they were produced in glasshouses fairly extensively throughout most of the Empire. There are no known examples from Egypt, however, which suggests that they were not made there.

They were made of very poor quality glass with many bubbles and flaws. The glass was colourless, dull transparent white or naturally tinted pale blue or green.

No recognisable specimens of this type are known from Corbridge but a number, including at least two complete examples, and several others in a more fragmentary condition, have been found at York.

This is a late type of unguentarium which replaced some of the earlier forms and became particularly popular in the fourth century. Unfortunately only a few of the many specimens which have been found come from dateable contexts. These, from Continental sites, indicate a late third to fourth century date.

Suggested date: A.D. 280-390.

See also: M.J. Form 32. Isings Form 105.

.....

Type 5. Square Bodied Unguentarium.

Figure 1. (5) Corbridge (reconstructed).

These unguentaria, which probably contained some special, expensive perfume or oil, were mould-blown. They have long thin necks ending in turned over rims, and square bodies. The bodies are usually of fairly thick glass, although the necks are thinner and more fragile. The bases are often decorated with moulded patterns or figures and there are often letters in the corners. These designs were probably trade marks. (See Note (ii), Page 67). One particularly common decoration is a figure of Mercury. Hence these vessels are sometimes called "Mercury Bottles". They are found frequently on sites on the Continent, and an apparent uniformity of fabric suggests that they were probably produced in one centre, although the exact place of origin is uncertain.

These vessels were usually made of green glass with a yellow tinge, although some almost colourless examples are known.

Fragments of several vessels of this type have been found at Corbridge including necks, and bases decorated with moulded concentric circles or a circle with a cross. These examples are of pale green glass. An example of a vessel of this type in white glass was found at Benwell in a lead coffin.

The earliest dateable example of an unguentarium of this form was found in a grave at St. Remy in France. This is probably of Flavian date, but the type did not become popular or widespread until the second century. It appears that they were produced during the second and into the third century, and they continued in use for some time after this.

Suggested date: A.D. 100-250.

See also: M.J. Form 19. Isings Form 84.

.....

Type 6. Candlestick Unguentarium.

Figure 1. (6) Chesters (reconstructed).

These vessels have long narrow necks and very short, usually conical. bodies. The necks are usually finished with turned-over rims. Candlestick unguentaria were first produced in the Eastern glasshouses, although their wide distribution on the Continent suggests that they were also produced in Europe.

They were usually made of natural coloured pale blue or green tinted glass, although colourless examples are known.

This type is represented in the Corbridge collection by a fragment of the neck and body of a candlestick unguentarium in natural pale green glass. The body with part of the neck of a similar vessel was found at Chesters, and it has been suggested that the neck of a vessel found at Balmuildy is also part of an unguentarium of this type. Complete examples of Candlestick unguentaria have been found at Southwark and at Bartlow Hills, Essex.

These perfume flasks were particularly popular during the second century. Dateable examples have been found at Colchester, on a number of sites on the Continent, and at Karanis in Egypt. The form probably originated towards the end of the first century and it continued until at least the mid-third century.

Suggested date: A.D. 90-240.

See also M.J. Form 25. Isings Form 82.

.....

Type 7. Unguentarium.

Figure 1. (7a) York. (7b) Corbridge (reconstructed).

These vessels are usually fairly tall and they have a triangular body about  $\frac{1}{4}$  to  $\frac{1}{3}$  of the total height. The walls are thin and the neck ends in an out-turned rim. They were produced in both Eastern and Continental glasshouses but the examples which reached Britain are probably Continental.

They were made of poor quality natural blue or green tinted glass.

At Corbridge the base with part of the body of an unguentarium of this form was found. This vessel was made of pale green glass which appears slightly opaque with a white tint. Similar vessels have been found at York and Colchester.

Vessels of this type were first produced in the middle of the first century. The majority of the dateable examples can be assigned to the late first or the second century, although there is strong evidence, particularly from the stratification of the examples found at Karanis, that vessels of this type continued in use until the fourth century.

Suggested date: A.D. 70-240.

See also: M.J. Form 24. Isings Form 28b.

.....

Type 8. Unguentarium.Figure 1. (8) Colchester (reconstructed).

Perfume bottles of this type are similar to those of type 7 but the triangular body occupies  $\frac{1}{2}$  of the total height. These vessels were produced in both Eastern and Continental glasshouses.

They were usually made of natural tinted glass often with many bubbles and flaws, although coloured, better quality examples are known. Part of an unguentarium of this type, made of pale green glass, was found at Corbridge. Other examples have been found at Colchester and Verulamium, whilst a particularly interesting specimen was found in London. This was made of

variegated glass with yellow and green streaks in it.

This type was produced slightly earlier than type 7. The example found at Colchester came from a period 4 layer, which means that it must date to the period 49-60. The London specimen was found in association with first century glazed pottery. This is further evidence for the early dating of the type. It did, however, continue in use over a long period. The Verulamium specimen can be dated to the first or second century. This type probably did not continue beyond the end of the second century.

Suggested date: A.D. 70-200.

See also: M.J. Form 22. Isings Form 28a.

. . . . .

Type 9. Small Squat Unguentarium.

Figure 1. (9) York. (reconstructed).

These vessels, like types 7 and 8, have triangular bodies but they are squat, and the necks are shorter and proportionately wider than those of the other types. On the bases of some examples there are moulded letters or decoration, probably a trade mark. (See Note (ii), Page 67). The place of manufacture is uncertain, for the type is found both in Europe and in Egypt.

These vessels were made of poor quality, natural coloured blue-green glass with many impurities.

This type of unguentarium is not represented at Corbridge, but at York a particularly interesting example was found in a cemetery. On the base, which is incomplete, are the letters PATRIMO which is part of the mark PATRIMONI - possibly an indication that the vessels or their contents were manufactured on an imperial estate. This trade mark has been found on several unguentaria on the Continent in Gaul, Rome and Cologne, and in Britain at Lincoln, Densworth (Sussex), London, Chester, and Bath.

These unguentaria were first produced towards the end of the first century. One example from Nimes was found in association with a coin of

Trajan, and the historical context of the York specimen indicates a late first or second century date.

Suggested date: A.D. 90-190.

.....

Type 10. Bulbous Unguentarium.

Figure 1. (10) York.

These vessels, which were made both on a core and by blowing, have a short neck and a bulbous body with a flattened base. The earliest examples of this type of vessel have the neck rounded off and polished, whilst the later examples have a rim. Perfume flasks of this type are found throughout the Roman Empire but the factories which produced them may have been Eastern or Continental, or both.

The earliest examples were made of coloured and decorative variegated glass, but, owing to the decline in popularity of decorative vessels, the majority of later examples were made of natural blue-green glass.

This type is represented at Corbridge by fragments of two vessels: one a base, the other a rim and neck, both of pale blue tinted glass. Examples have also been found at Red House Corbridge, South Shields, and York. The British Museum collection includes an unguentarium of this type in yellowish-buff glass, found at Chester.

Vessels of this type were first produced in the middle of the first century. Their early popularity is illustrated by the large numbers found at Pompeii and Herculaneum. Other Continental examples found in dateable contexts indicate that the type continued until at least the end of the second century.

Suggested date: A.D. 70-190.

See also: M.J. Form 37. Isings Form 26.

\*\*\*\*\*

FLASKS

(Types 11-12.)

Fragments of flasks are common on all Roman sites. They were widely produced throughout the early Roman period. Some, like the "dolphin flasks" type 11, had a specific function as containers of bath oils, whilst the plainer, bulbous-bodied flasks had a more general function as container vessels.

\* \* \* \* \*

Type 11. Aryballos.

Figure 2. (11a) Corbridge. (11b) Carrawburgh (reconstructed).

These vessels, which are sometimes called Balsamaria, were used to contain bath oils. The prototypes of this form were made of metal but the glass ones soon became very popular and their production continued for some considerable time. The size and shape of the flasks varies little. They have round bodies, very short necks with polished rims, and two small round handles, to which were fastened a bronze handle and a chain by which the oil flask was attached to the bather's arm. The small glass handles often resemble fantastic fish and hence the vessels are commonly known as "dolphin flasks". These vessels were closed by means of a bronze stopper. The earliest vessels of this type were made of decorative coloured glass in Egyptian glasshouses by the sand-core process. Later they were produced by glass blowing, on the Continent. Natural coloured glass was used, although some decorations were added in the form of coloured handles or trails of coloured glass. Some examples are known which were decorated with delicate cut patterns.

The metal from which these vessels were made varied according to the tastes of the Romans. Early examples were of good quality coloured glass, whilst in the later period poor quality natural coloured glass and finer

colourless and crystal glass were used.

At Corbridge a very fine example of a vessel of this type was discovered in a rubbish pit. The flask, which is made of pale blue glass with green handles is complete and all the metal fittings are also intact. In the Corbridge collection there are also several rims of similar vessels. Examples have also been found at Housesteads, Great Chesters and South Shields. At Carrawburgh, part of an aryballos, with trailed decorations on the body, has been found. This can be compared with a similar vessel from Cologne. Another example of an aryballos was found near Richborough, in association with samian pottery of Flavian date. Other examples are known from Southwark and Lincoln.

Although this type of vessel was produced in the Eastern and Egyptian glasshouses by the sand-core process in the centuries before the Christian era, it was the plainer, blown glass variety which became popular on the Continent and in Britain during the Flavian period. The type was particularly popular in the closing years of the first century and well into the second century. It was less popular during the third century, although dateable examples are known and at least one has been found in a fourth-century context on the Continent, although by this time the type was becoming very rare.

Suggested date: A.D. 70-240.

See also: M.J. Form 33. Isings Form 61.

.....

Type 12. Bulbous Flask.

Figure 2. (12) Corbridge (reconstructed).

Flasks of this type were probably used to contain wine or oil. In shape they are similar to type 10 with a bulbous body, a kick in the base, and a neck tapering to the rim. Some of them are decorated with wheel-incised lines, trails and other decorations. This form was very common and it was

produced throughout the Empire.

They were usually made of rather thick pale blue or green glass.

At least two examples of the plain form of this type are represented at Corbridge, and there is also an unusual small vessel of this form decorated with small projections all over the body. Fragments of other vessels of this type have been found at Balmuildy, South Shields, in the cemetery at Bartlow Hills, Essex, and in a first-century context at Colchester.

The earliest vessels of this type were probably produced in the second quarter of the first century and they were popular throughout the first century and into the second century, but their popularity gradually diminished and the form died out.

Suggested date: A.D. 70-150.

See also: M.J. Form 39. Isings Form 16.

\* \* \* \* \*

FLAGONS.

(Types 13-17.)

A number of different types of flagons and jugs were produced during the Roman period. Some of these must be looked upon as utility container vessels which were probably brought into this country containing wine from the Continent and particularly the Rhineland. Some of the more elaborate flagons, however, were probably decanters, into which the wine was poured from larger storage vessels. This means that they would be expensive and probably only the wealthy army officers and civilians could afford to buy them. These were also the type of valuable heirlooms which were placed in the graves of the wealthy.

\* \* \* \* \*

Type 13. Bulbous Flagon.Figure 2. (13a) Richborough. (13b) British Museum.

The bodies of these flagons are basically the same shape as the flasks in type 12, but the vessels usually have footstands and the necks are elongated. They usually have strap-like handles, with one or more raised ribs, which are attached to the neck of the flagon either at the rim or half way down. At the junction with the vessel itself, the handle divides into a number of terminals, which are placed on either side of the vessel. A number of vessels of this type have been found with tapering ribs on the body for decoration and probably as a form of strengthening, whilst other specimens are known with blobs of coloured glass marvered into the walls for decoration. Flagons of this type are found frequently on the Continent and it is clear that they were amongst the most important products of the glasshouses in the Rhineland.

These flagons were made of fairly good quality glass, both coloured in shades of blue, yellow and brown, or natural tinted.

A number of fragments of flagons of this form, both with plain and ribbed bodies, have been found at Corbridge in several colours of glass. A few of these are parts of the walls, whilst several handles, rims and necks are amongst the collection. Complete, or almost complete, bulbous flagons have been found at Colchester, Bayford in Kent, Littlington and Bartlow Hills, usually in cemetery contexts.

These flagons were first produced in the mid-first century, and they were popular during the Flavian period. More elaborate forms were adopted in the second century but this basic type continued throughout the century before it died out.

Suggested date: A.D. 70-180.

See also: M.J. Form 45. Isings Form 52.

.....

Type 14. Conical Flagon.

Figure 3. (14a) Barnwell. (14b) Corbridge (reconstructed).

These vessels have cone-shaped bodies, often with a slight kick in the base. The length of the neck varies greatly and there is usually a flattened rim. In some cases the neck is short in comparison to the total height of the vessel, whilst other flagons of this form have long, slender, elegant necks. The handle is usually flattened and strap-like with one or more ribs. On some examples the handle is decorated by the addition of a strip of glass which had been pinched to give a beaded effect. This is placed at the end of the handle at the point of junction with the vessel and it continues down the body. The bodies of these vessels are sometimes decorated with wheel-incised lines or ribs, and in some cases the flagon was twisted in the mould during manufacture, producing a very decorative spiral effect on the neck and body. This type of vessel is found frequently on sites in Germany and on the Continent. Dr. Fremersdorf argues that they were produced in Gaul, but

58a  
PLATE IV.

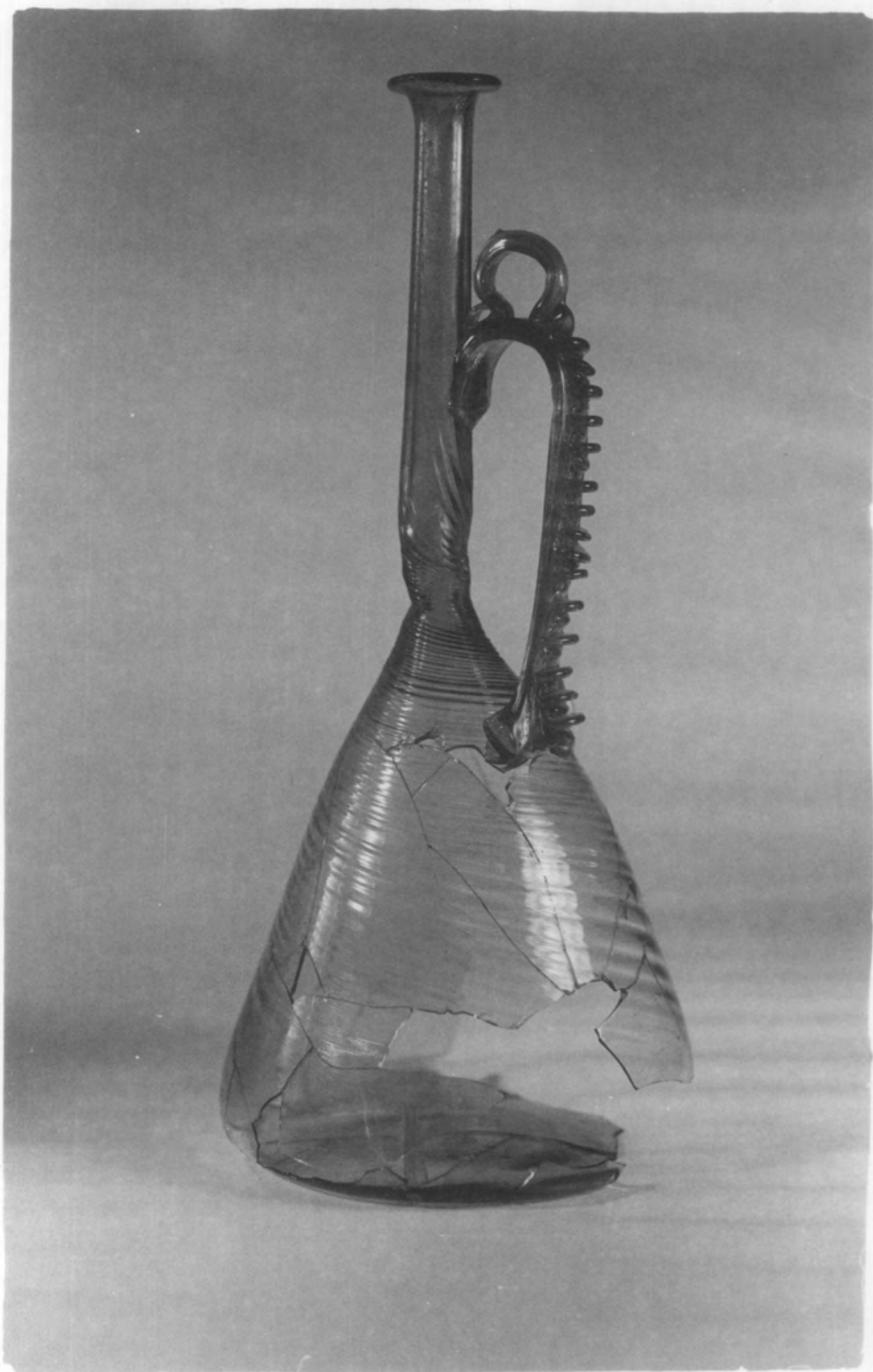

A Glass Flagon found at  
Corstopitum, Corbridge  
in 1968.

probably the type was also adopted by the German glasshouses.

Flagons of this type were made of either natural green coloured glass, or deliberately coloured glass in yellow, brown, blue and green tings. They were often thin walled and the glass was usually of a fairly good quality.

At Corbridge a particularly fine specimen was found. It was in a number of fragments but it has been possible to reconstruct it almost entirely. It is made of pale green glass and it is very thin walled.

The body of this flagon shows a definite spiral and there is a slight flaw in the base of the neck where the glass was twisted into too tight a spiral. The neck is constricted at the base but it swells slightly before tapering again to the out-turned circular lip. The strap-like handle is attached to the body in a fishtail junction, the outer ends of which are raised into flat semicircular wings, which are almost at right angles to the body of the vessel. On the upper surface of the handle a "ribbon" of molten glass was placed ornamentally, giving a beaded effect. Unlike most of the decorated vessels of this type, the decorative strip runs along the whole handle, not just the base. At the point of junction with the handle this decorative ribbon is turned to form two small rings.

There are also fragments of three other vessels of this type in the Corbridge collection, all in yellow glass, and all showing evidence of spiral twisting. A similar flagon to the Corbridge specimen was found at Turriff in Aberdeenshire. This vessel was not in association with any Roman structures and its discovery is something of a mystery, but it may be that the vessel was associated with a Roman burial, all evidence of which had either disappeared or been overlooked when the discovery was made. Parallels can be cited from Faversham, Barnwell in Cambridgeshire, Radnage in Buckinghamshire, London and Richborough.

These flagons were first produced in the mid-first century. There is evidence for their increasing popularity in the closing years of the first

century but they remained in production well into the second century before dying out in the closing decades.

Suggested date: A.D. 70-160.

See also: M.J. Form 57. Isings Form 55.

.....

Type 15. Two-handled Conical Flagon on a Footstand.

Figure 3. (15) Bayford.

This type is a development of type 14. The body is conical, and vessels of this form have footstands. The neck is long and slender and it terminates in a flattened rim. The strap-like handles which have one or more ribs are on opposite sides of the vessel. One is attached to the neck at the rim, whilst the other is joined half way down the neck. The handles are usually decorated with a strip of glass pinched to give a beaded effect and this continues down the body of the vessel. Some flagons of this type have ribbed bodies. These vessels, like type 14 were probably made on the Continent.

They were made of fine good quality glass, which was either natural green tinted or deliberately coloured.

At Corbridge, part of the base and wall of a vessel of this type, made of dark yellow-brown glass, has been found. A number of other sites have yielded handles which may belong to similar vessels. The British Museum collection includes a fine complete example of a flagon of this type in pale olive-green glass, found in a grave at Bayford in Kent.

Since these vessels are a development of the conical flagon, it would be reasonable to assume that they were introduced rather later, probably in the closing years of the first century. They were in use during the second century and possibly into the third, although by this time they were becoming much rarer.

Suggested date: A.D. 90-180.

See also: M.J. Form 58.

.....

Type 16. Globular Flagon.Figure 4. (16) Bexhill.

These flagons are a development of type 14 and they have many similarities to the conical flagon. The rim and neck is the same but the sides of the body are slightly convex, and the body is more rounded. The base has a very pronounced 'kick' which may stretch half way up the body inside the vessel. The handle on these flagons is generally three or four ribbed, and it is attached to the shoulder of the flagon by a claw-like join, which is sometimes decorated by the addition of an extra "ribbon" of glass. Some of these vessels have a Medusa-head medallion on the body. These are very distinctive and in some cases they are the only part of the flagon to survive. Like the conical flagons, these vessels were probably produced in the glasshouses throughout the Continent.

They were usually made of fine, good quality glass, which was either deliberately coloured or natural tinted.

A medallion from a globular flagon was found at Piercebridge, and other medallions have been found at London and Caerleon, whilst fragments of flagons of this type were found at Richborough. A complete example was found in a lead coffin at Bexhill in Kent. This is now in the British Museum.

These vessels were probably produced during the same period as the flagons of type 15. The historical context in which the Richborough example was found suggests a middle to late first-century date and the London example would support this. The Bexhill example, however, is dated to the late second century, which indicates that the type remained in use for some time.

Suggested date: A.D. 90-180.

.....

Type 17. Ovoid Jug.

Figure 4. (17a) British Museum. (17b) Colchester.

These vessels have an ovoid body on a footstand. They have short necks broadening towards the mouths which are finished with one or more turned over rims. The simple form has a plain strap handle, which is twisted into a loop at the point of junction with the neck. A variant of this form has a two-strand handle, which is twisted to resemble a chain. Vessels of this type are common on the Continent and it appears that they were made in the glasshouses in the Rhineland.

Many elaborate coloured specimens of this form have been found made of blue, green and variegated glass, although plainer examples are known.

This form of vessel is represented at Corbridge by a fragment of decorative green-yellow tinted glass, probably from a jug of this form with a double-strand handle. These distinctive double-strand handles have been found at Birrens and Piercebridge, indicating that vessels of this type must have been in use there. Complete jugs of this type have been found at Bayford-next-Sittingbourne and Colchester, whilst fragments of one were found at Verulamium.

These vessels are a development of the flagons of types 13-16. The change occurred towards the end of the second century as the earlier types were dying out. The vessels became particularly popular towards the middle of the third century and they continued in use during the fourth and into the fifth centuries.

Suggested date: A.D. 190-350.

See also: M.J. Form 50. Isings Form 120.

\* \* \* \* \*

BOTTLES

(Types 18-21).

Container vessels of various sizes are very common on Roman sites. They were all, strictly functional and they were not intended to be ornamental or decorative. They probably contained wine but may have been used for oil or other liquids. They are found frequently in cemeteries. In some cases they were used as cinerary urns but they were also used to contain requisites for the after-life.

These vessels were mostly mould-blown and they were produced throughout the Roman Empire.

\* \* \* \* \*

Type 18. Cylindrical Bottle.

Figure 5. (18a) Corbridge (reconstructed). (18b) Richborough.  
(18c) Corbridge.

---

These vessels have cylindrical bodies, short necks, and out-folded rims over which the stopper ties could be fastened. The walls often have many vertical scratches on the outside. This scratching, which is not found on any other form of vessel, was probably caused by grit rubbing between the plaited or wicker-work case which, it is thought, surrounded the bottle, and the vessel itself. These vessels also have heavy ribbed handles which are very similar to the handles of types 19-21. The height varies considerably. Some vessels are squat and short in comparison to the diameter, whilst the more common vessels of this type are taller. There was often a moulded decoration on the base which usually took the form of concentric circles, although other designs are also known. These vessels are very common and they were made throughout the Empire. It is possible that some were produced in the glass works in Britain.

They were made of heavy glass in natural blue and green tints with many bubbles and flaws.

The Corbridge collection includes many fragments of vessels of this type including parts of the necks, shoulders, bases and handles in many shades of natural blue and green glass. Part of a similar bottle was found at Newstead in an early pit, two bases have been found at Balmuildy, and fragments were found in an Antonine context at Castledykes. Complete examples have been found at Bartlow Hills and Colchester, and another was found at Richborough.

These cylindrical bottles were probably first produced in the middle of the first century. They continued in use during the second century, by the end of which the squat form died out, whilst the taller form continued in use into the third century.

Suggested date: A.D. 70-220.

See also: M.J. Form 8. Isings Form 51.

NOTE 1.

Decorated Cylindrical Bottles.

Whilst the majority of cylindrical bottles were made of heavy, natural tinted glass, a few were produced in good quality, colourless glass. Many of them were decorated with wheel-incised lines. An almost complete example of a bottle of this type was found at Corbridge, (Figure 5. (18c) It is made of almost colourless, white glass and it is very thin walled.

Decorated cylindrical bottles were later developed into barrel-shaped bottles. They have cylindrical bodies with two regions of blown bands. Probably the most interesting feature of these vessels is the moulded names on the bases. The most common name on these vessels is FRONTINUS, and hence these bottles are known as "Frontinus Bottles".

These decorative vessels were produced in the glasshouses in North Gaul and they are found frequently throughout the Continent. They reach the South of Britain but they do not appear to be found in North Britain.

They were produced in the late second century and they became increasingly popular during the third century.

.....

Type 19. Square Bottle.

Figure 6. (19a) Carlisle. (19b) Coventina's Well, Carrawburgh.

These are probably the most common of all Roman glass vessels. They

have square-shaped bodies, the height of which varies considerably, short necks, rims, and each has a single ribbed handle. The shape was obviously one which was practical and the vessels could be easily stacked. They were made in two ways. The majority were mould-blown and these had thick walls; the others were free-blown and the walls, which were thinner than those of the mould-blown bottles, were flattened into shape after blowing. There are many designs on the bases. The most common is concentric circles, although many other designs, chiefly involving circles, have also been found. These bottles were probably made to contain wine or some other liquid, but they also had a secondary function as cinerary urns. Several complete examples containing ashes have been found in cemeteries. The free-blown /examples of this type of vessel were made in the glasshouses in the Mediterranean area whilst the mould-made square bottles were produced throughout the Empire, and it is possible that some were made in Britain.

These vessels were made of poor quality natural coloured blue and green tinted glass.

Square bottles are very common on all Roman sites and the Corbridge collection includes very many fragments of bases, walls, shoulders, necks and handles of this distinctive type in pale green glass. Almost all Roman sites in Britain have yielded fragments of these bottles and museum collections include many complete examples. An interesting tall square bottle was found in Coventina's Well at Carrawburgh whilst a small square bottle was found at Carlisle. The Tullie House Museum, Carlisle, also has in its collection a large square bottle filled with ashes, which was found in a cemetery in the city. (See Plate V, Page 65a).

These vessels were produced in the first century and because they were purely practical container vessels, the type remained unchanged throughout much of the Roman period, although it appears that it was not produced after the beginning of the fourth century.

65a  
PLATE V.



Square Glass Bottle  
in use as a Cinerary Urn.

(Tullie House Museum, Carlisle.)

Suggested date: A.D. 70-300.

See also: M.J. Form 14. Isings Form 50.

.....

Type 20. Rectangular Bottle.

Figure 6. (20) Corbridge (reconstructed).

These vessels are very similar to the square bottles of type 19 and it is probable that many fragments of these are mistaken for parts of square bottles. The bases are rectangular and, like square bottles, they have moulded decorations and names on them. The walls are flattened and the bottles have short necks, rims and one or two ribbed handles. The vessels, which were less common than the square bottles, were probably made throughout the Empire.

They were made of fairly heavy, natural coloured green and blue glass.

The Corbridge collection includes a number of rectangular bottles including the bases of two vessels, one with the letters S.A.A. moulded on it, and the other with S.A. (See Plate VI, Page 68a) These were clearly made in the same mould. There is also another decorated base; part of the neck, handle and walls; a wall fragment; and the neck and shoulder of a bottle of this type. They are in different tints of natural blue and green glass. A number of complete rectangular bottles have been found, chiefly in cemeteries, at Colchester, Southwark and Bartlow Hills, Essex.

These bottles were probably introduced towards the end of the first century A.D. and, after being particularly popular during the second century, they remained in use during the third and into the fourth centuries.

Suggested date: A.D. 90-320.

See also: M.J. Form 16. Isings Form 90.

.....

Type 21. Hexagonal Bottle.

Figure 6. (21a) York. (21b) Corbridge (reconstructed).

This type of bottle is much less common than the square and rectangular bottles, but it is possible that fragments of these are mistaken for the other more common types. These bottles, which vary considerably in size, have hexagonal bodies, with short, narrow necks, rims and ribbed handles. They were mould-blown and they usually have moulded designs on the base. The most common of these is concentric circles, although other designs are also found. These vessels are fairly common on the Continent and it is probable that they were made in the glasshouses in Gaul and possibly also in those on the Rhine.

They were made of natural coloured green and blue glass.

At Corbridge an almost complete body of a vessel of this type in pale green glass was discovered. It is broken at the beginning of the neck, and the point where the handle was attached is just visible. On the base are several moulded concentric circles. The Corbridge collection also includes the base of a much larger hexagonal bottle in green glass, again with moulded concentric circles. A very small bottle of this type was found in a cemetery at York. A very large example, now in a rather fragmentary condition, was found in 1820 in a barrow near Wharram-le-Street. It is now in the Yorkshire Museum, York. Part of the base of a similar vessel was found at Balmuildy and examples have also been found at Exeter and Pen Llystyn.

These bottles, like type 20 are a development of the basic square bottle, and it is likely that they were first produced around the end of the first century. They continued in use during the second century, when they were particularly popular, and for some time into the third century, although it is doubtful whether they remained in circulation for as long as the rectangular bottles.

Suggested date: A.D. 90-250.

See also: M.J. Form 17.

NOTE 2.

Moulded designs on the bases of glass bottles.

An interesting feature of the heavy, mould-blown, angular and

cylindrical glass bottles which were used in Roman times to transport liquids, is the moulded designs on the bases. The most common design is a series of concentric circles, although a considerable number of other geometric designs are also found. (For a selection of Corbridge and other North British designs see Plate VI). A few of the specimens have moulded letters on them. This includes the square bottles, from Carrawburgh with the letters CCPC moulded on the base, and the rectangular bottle from Corbridge with the letters SAA. Particularly well-known examples of moulding on the base of bottles are the barrel jugs or Frontinus bottles. (See Note 1, Page 64), so called because the letters FRONTINUS are moulded on the base. A number of other names have also been found on these bottles, but FRONTINUS is by far the most common. Moulded names are also occasionally found on the bases of Unguentaria, such as the base with the name PATRIMONI on it which has been found at York and on other sites in Britain. (See Type 9.)

The exact function of the moulded designs is uncertain. Their original purpose may have been purely practical, to lift the base of the bottle off the surface on which it was standing, to enable cooling or to prevent it sticking, although it would be reasonable to assume that the designs and names soon became trade marks. A parallel to this can be seen on Roman flue tiles. Designs were originally put on the surface of the tiles to provide a rough surface to which the plaster would stick, but the tile makers soon adopted these designs, some of which were very elaborate, and established them as trade marks. If, as it would be reasonable to assume, the designs on the bases of bottles were trade marks, another problem remains. Was the trade mark that of the maker of the bottle or did it in some way indicate the contents of the bottle? I suspect that the answer to this will remain a mystery. It may be that in some cases, such as the Unguentaria with PATRIMONI on the base, the name indicates the name of the maker of the perfume or oil which the bottle contained, whilst FRONTINUS bottles were probably decanters and then the maker of the vessel would be the person who was advertising his wares in this way. The designs on the bases of the majority of the everyday household vessels were probably factory marks, although as I have already noted it is doubtful whether their exact function will ever be known.

\* \* \* \* \*

# BASES OF BOTTLES. MOULDED DESIGNS.

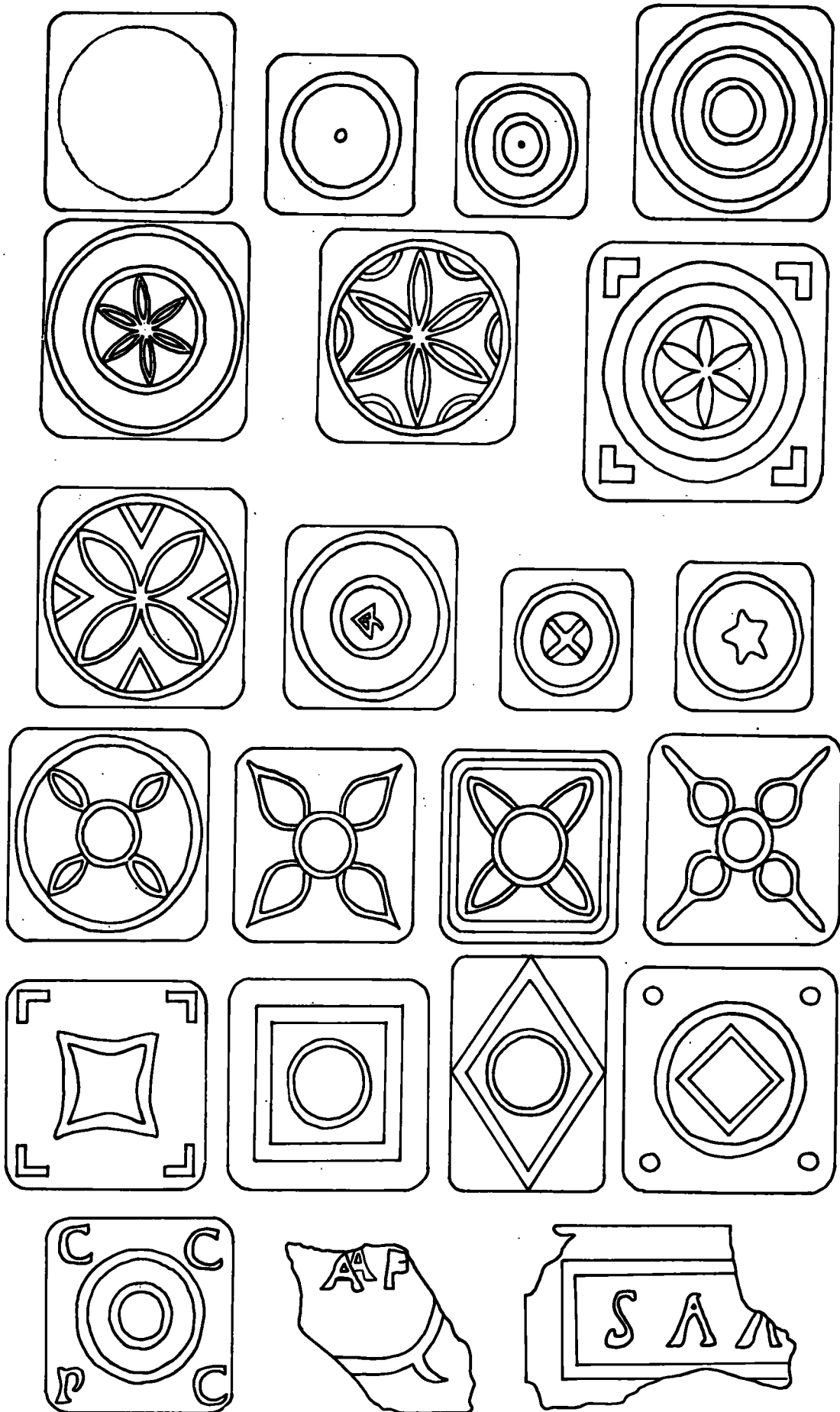

JARS.

(Types 22-24).

Large storage jars of various shapes are common on Roman sites. They of were usually/fairly fine glass which was either deliberately coloured in shades of blue, yellow and brown, or natural coloured with pale green and blue tints. Some of the jars had lids, but these are found very rarely. Like some types of bottles, glass jars had a secondary function as cinerary urns and others were placed in graves.

\* \* \* \* \*

Type 22. Jar with M. Shaped Handles.Figure 7. (22) Corbridge (reconstructed).

This is one of the most common types of storage jar. The body is bulbous with a kick in the base, and the vessel usually has a short, broad neck with a rim folded outwards and downwards. The M shaped handles are attached on opposite sides of the vessel, just above the widest point on the body and they also touch the rim. These vessels are found widely throughout the Empire. They were clearly made both in Eastern and Continental centres.

The vessels were made of fairly fine, good quality glass, chiefly in natural blue-green tints.

This type of vessel is represented in the Corbridge collection by several fragments, chiefly of walls, rims and handles, in pale green glass. A complete vessel of this form was found at Southfleet in Kent. It was made of pale bluish-green glass and it was full of bones. This is now in the British Museum. Whilst the original function of the vessels was purely domestic, it is as cinerary urns that they are frequently found, and it may be assumed that excavations in cemeteries will yield more of them.

These jars originated in the second half of the first century and they

continued in use throughout the second century. A few examples have been found on the Continent in a third century context, but these may have been survivals of a type which had largely died out by this time.

Suggested date: A.D. 70-180.

See also: M.J. Form 2. Isings Form 63.

.....

Type 23. Ovoid Jar.

Figure 7. (23) York.

These vessels are ovoid in shape with a kick in the base. They have no necks, but each jar is finished with a rim which is folded outwards, downwards and inwards and it is usually flattened. They are very common on all Roman sites and clearly they were manufactured throughout the Empire. They had a secondary function as cinerary urns, and some decorated examples have been found in cemeteries on the Continent.

These vessels are fairly thin walled and the glass is usually of a good quality, with few impurities. Examples have been found in both natural tinted and coloured glass.

In the Corbridge collection there are at least two rims which could belong to vessels of this type, one in natural pale green glass, and the other in deep yellow glass. Part of a similar vessel was found at Chesters. A complete jar was found at York in a cemetery and this example also had a glass lid. Another was found at Hemel Hempstead, full of cremated bones, and others are known from London, Verulamium and Colchester.

This type was first produced in the second half of the first century and it continued throughout the second and into the early third century.

Suggested date: A.D. 70-230.

See also: M.J. Form 1. Isings Form 67.

.....

Type 24. Jar with Ribbed Body.Figure 7. (24) Colchester.

These vessels are the same basic shape as type 23 but they have a base ring and a more elaborate rim. The thin walls are decorated and strengthened by ribs which are fairly broad at the rim but taper towards the base. The rim is turned over and rounded and it is then extended and flattened to give the effect of a double rim. These vessels were produced in the glasshouses on the Rhine and in Gaul and they are found frequently in the northern provinces of the Empire.

They were made of good quality blue and yellow coloured glass, although specimens are known in natural tinted glass.

The Corbridge collection includes many fragments of these ribbed jars in yellow and green coloured glass, and the type is represented on other North British sites. A number of fragments from a jar of this type made of dark blue glass were found at Malton. (See Appendix 3). A particularly fine, complete example was found in a cemetery at Colchester. This vessel, which is made of amber coloured glass is now in the Colchester Museum. Fragments of these jars are found fairly frequently on sites, but unless a rim is found, as for example at Verulamium, the type may be overlooked.

This type was first produced at the end of the first century. It was in circulation throughout the second century but it died out at the beginning of the third.

Suggested date: A.D. 90-190.

See also: Isings Form 67c.

\* \* \* \* \*

BEAKERS.

(Types 25-30).

Glass drinking vessels, or beakers, are common on Roman sites. They are often of very utilitarian types, although some much more delicate, fine, cut glass vessels also fall into this category. They were produced widely throughout the Empire and most of the types continued in use throughout most of the Roman period.

\* \* \* \* \*

Type 25. Plain Beaker.Figure 8. (25) Reims (from M.J.).

These vessels are almost straight-sided and there is a slight constriction before the outflaring mouth. The base is a solid footstand with a definite central 'kick'. The walls are usually undecorated, although there are examples which are decorated with trailed horizontal lines. These are fairly utilitarian vessels and they were produced widely throughout the Empire.

They were made of fine, good quality glass which was usually colourless or white.

The Corbridge collection includes the rim, walls and base of an undecorated example made of colourless glass, and part of the rim and walls of a beaker with a trailed decorative line in white to colourless, transparent glass. These vessels are found frequently on Roman sites in the North of Britain. Of particular note are a number of fragments found in the Commandant's House at Housesteads. Examples are also known from South Shields and Malton.

The vessels were first produced in the middle years of the first century and they were in use until the end of the second century and possibly into the third.

Suggested date: A.D. 70-210.

See also: M.J. Form 109.

. . . . .

Type 26. Beaker with Wheel-Incised Lines.

Figure 8. (26) Colchester.

The walls of these beakers taper towards the base. Several different types of base are found on these vessels including rings and solid pads. They have smooth turned-over rims. The walls are decorated with bands of wheel-incised lines. Examples of this type of beaker are found on sites throughout the Empire and it is probable that they were made both on the Continent and in the Eastern glasshouses.

They were usually made of good quality white to colourless glass, although later examples were of poorer quality and naturally tinted.

Fragments of at least five vessels of this type, made of white and colourless glass, have been found at Corbridge. Parallels can be cited from Housesteads, Chesters, Newstead and York in the North, and London, Richborough and Lincoln in the South.

These beakers were first produced in the first century and the form continued for the majority of the Roman period. Some indication as to the date of a beaker may be obtained by examining the glass, since there was a decline in the quality of the glass in the later centuries.

Suggested date: A.D. 70-400.

See also: Isings Form 34.

. . . . .

Type 27. Beaker with Indented Sides.

Figure 8. (27) South Shields (reconstructed)

These vessels vary quite considerably in shape and size but they have one common feature - thumb indents on the sides. The earliest examples are fairly tall, conical in shape, with a cut-out base and long oval indents.

Others have a slightly convex outline flaring to the mouth, and a concave base. These have four indents which make the vessel appear almost square shaped. These beakers were produced in the Mediterranean area.

They were made of very poor quality glass, usually natural green coloured, although some dull colourless examples are also known.

This type of vessel is represented at Corbridge by part of the base and walls of a beaker in dull white, translucent glass. Examples are also known from South Shields, Malton, and Balmuildy, and in the South of Britain from Exeter and Richborough.

These beakers were first produced towards the end of the first century and it appears that they remained in use throughout most of the Roman period, at least until around the middle of the fourth century.

Suggested date: A.D. 70-340.

See also: Isings Forms 32 and 35.

.....

Type 28. Facet-Cut Beaker.

Figure 8. (28) London (reconstructed).

These very distinctive, fine vessels have straight sides sloping towards a solid base. The finishing of the rims varies, but the North British examples have moulded rims. Above and below the panel of interleaved facets are either fine ground ribs or cut grooves. The shape of the facets varies considerably. Some are oval whilst others are diamond shaped. Other styles of facet are also known but these are less common and they are found chiefly on the Continent. The beakers are found frequently on Roman sites, and Northern Italy was a particularly important centre of manufacture, although they were made throughout the Empire.

They were made of fine, good quality, white to colourless crystal glass.

The Corbridge collection includes four fragments of vessels of this type,

74a

PLATE VII.



A Facet Cut Beaker from Syria.

(The Manchester Museum.)

three with oval shaped facets, and one with circular facets. A fragment of a fine beaker of this type was found during excavations at Birrens, and examples are also known from Castlecary, Castledykes, Piercebridge, Lyne in Peebleshire, Gellygaer, Caerleon, Richborough, Stanton Chair Villa, Caistor by Norwich, Verulamium, Barnwell in Cambridgeshire and London.

These beakers were first produced in the middle of the first century. The basic type continued throughout most of the Roman period but there was a change in the style of the decoration and the shape of the facets, so that early and late examples can be recognised. The early ones have an open diaper of shallow facets, whilst in the third century the facets became more circular in shape and they were generally much coarser.

Suggested date: A.D. 70-350.

See also: Isings Form 21.

.....

Type 29. Funnel Shaped Beaker.

Figure 8. (29) Sablonniere (from M.J.).

These vessels have straight sides which taper towards a flattened base. They have very thin walls which flare out slightly towards the mouth, which is usually unfinished. They are found fairly extensively throughout the Empire, and they were made in both Eastern and Continental glasshouses, although the British examples probably came from the Continent.

They were made of very poor quality, dull, colourless or natural tinted glass with many bubbles and flaws.

Vessels of this type are represented at Corbridge by part of the rim and walls of a beaker, in pale green glass of very poor quality with many flaws and bubbles in it. Part of a beaker of this form with trailed decoration was found at Traprain Law, and a similar vessel is known from Silchester.

This type of beaker was produced in the fourth century, and it was particularly popular in the second half of the fourth century, although it continued until the fifth century when it was replaced by the more elaborate Dark-Age forms.

Suggested date: A.D. 320-410.

See also: M.J. Form 107. Isings Form 106a.

.....

Type 30. Carinated Beaker.

Figure 8. (30) Corbridge (reconstructed).

There is a considerable variety of glass beakers with carinated sides. The greatest difference appears to be in the design of the base and the way in which the main body of the vessel joins the base. The most common type of base was a fairly high footstand, to which the vessel either tapered gradually or steeply, through the carination, or in some cases there was almost a stem between the body and the base. It is difficult to assign any specific place of origin to vessels of this type, but it may be generally assumed that, like the majority of the glass found in Britain, they came from one of the Continental centres and probably the Rhineland.

The quality of the glass varies although a colourless to white metal appears common.

At least three examples of these beakers have been found at Corbridge. They have definite footstands although the shape of the bodies varies considerably. Unfortunately none of the specimens is complete and reconstructions can be somewhat uncertain, particularly since few vessels of similar form have been found. Parallels can be noted from Hardknott, Jewry Wall in Leicester, Verulamium, Richborough, and a complete example was found at Crundale in Kent.

Just as there has been little definite dating evidence for the beakers

of types 25-29, so this type is difficult to date because very few of the known examples from Britain were found in dateable context. One of these was the pièce from Jewry Wall, Leicester, which could be dated to A.D. 180 whilst the Hardknott specimen can be dated to the period A.D. 125-170. It is likely, however, that this type was first produced in the late first century and continued at least until the mid third-century.

Suggested date: A.D. 90-250.

\* \* \* \* \*

BOWLS and PLATES

(Types 31-35).

Bowls and plates of a number of different types are found fairly frequently on Roman sites in North Britain. These vessels are usually easily recognised and they are particularly important because some of the types give valuable dating evidence.

\* \* \* \* \*

Type 31. Cylindrical Bowl.

Figure 9. (31a) Colchester (reconstructed).  
 (31b) Corbridge (reconstructed).

Vessels of this type vary considerably in size. Some are short and they would more accurately be described as dishes, whilst others are fairly tall. The earliest examples were mould-pressed whilst others were blown. They generally have cut out base rings and thick folded or rounded rims. Some of the small blown dishes of this type have a groove in the horizontal part of the rim, which may have been used to support a lid, although no suitable lids have in fact been found. A number of cylindrical bowls have been found in cemeteries on the Continent, and it appears that they were buried in sets of four. Examples have been found in Southern Italy, France and Germany which suggests that they were produced throughout the Continent.

Specimens have been found in coloured and natural tinted glass.

This type of vessel is represented in North Britain by a number of fragments of vessels from Corbridge and Chesters, including parts of the walls and bases. They were also found in York. More complete examples can be cited from Colchester.

This type of vessel was first produced in the middle of the first century and it remained in use until the middle of the second century.

Suggested date: A.D. 70-150.

See also: Isings Forms 22, 41, 48.

. . . . .

NOTE 3.Painted Glass Bowls.

On seven sites in the north of Britain, fragments of painted glass bowls have been found. Basically these bowls were cylindrical in shape (see Type 31), and they were made of good quality, colourless glass, on to which animal friezes and scenes from the arena were painted.

In Scandinavia, and particularly in Denmark, a number of complete bowls of this type have been found in graves, and it is particularly interesting to consider the North British examples in the light of these European parallels. Of particular note are three examples which are now in the National Museum in Copenhagen. On two of these, animals are portrayed, including leopards, tigers and hinds, whilst on the third, and probably the earliest of the bowls, a bestarius is portrayed with a bear and a bull, and a lion can also be seen, jumping on a hind. The pictures, which are artistically coloured rather than lifelike representations are surrounded and interspersed with dots and dashes, sometimes arranged in patterns, in bright colours.

The ancient glass workers who produced these vessels must have discovered a special type of paint, which was fixed in some way after it had been applied to ensure that it would not come off. The state of preservation of the colour on the bowls from Scandinavia and on the North British fragments is quite remarkable. An indication of the way in which the pictures were obtained can be seen on the fragment found at Vindolanda. There is a clear line scratched on the surface of the glass, obviously intended as a guide line for the paint, although the fact that the paint has over-run this line is proof of the difficulty which the workers found in painting glass.

The sites in North Britain which have yielded fragments of these bowls are Corbridge, Chesters, Vindolanda, Carrowburgh, Housesteads fort and vicus, and the native sites of Traprain Law and Clickhimin Broch. On the Corbridge fragment is painted the hindquarters of a blue leopard with black spots and white patches on the belly, thighs and tail. The Chesters fragment is part of the blue head, with the red mane and black spots of a similar leopard, and the decoration of this fragment also includes part of the border on the rim of the bowl. The Vindolanda piece, which was found at the beginning of the 1971 season of excavations shows the legs of a bestarius. The Carrowburgh piece has one brown and three blue spots on it, which are clearly part of the decorative detail. The fragment from Housesteads fort shows the blue paw of a leopard and part of the pink stripe which served as a border for the decoration. The piece found in the vicus at Housesteads is part of the decorative patterning of the bowl, and this piece is very similar to that found at Traprain Law.

It may be argued from the fact that bowls of this type have been found in Denmark, outside the Empire, and on native sites in Scotland, that they were used by the Romans as gifts,

PAINED GLASS BOWLS FROM NORTH BRITAIN - FRAGMENTS.

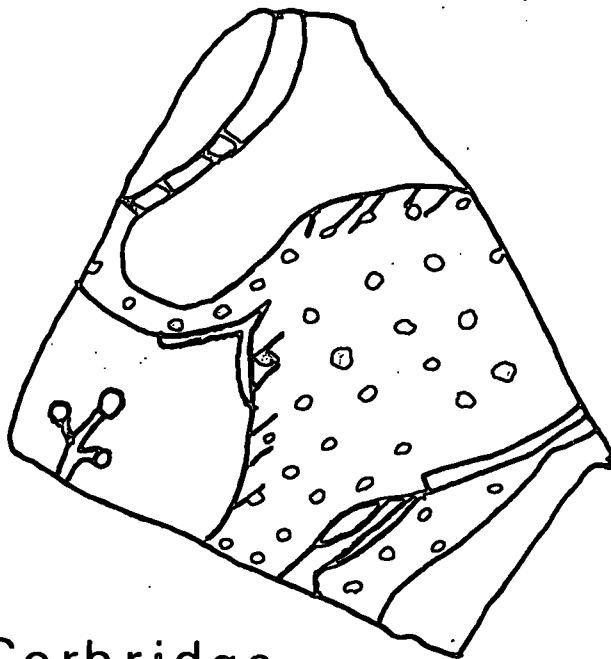

Corbridge

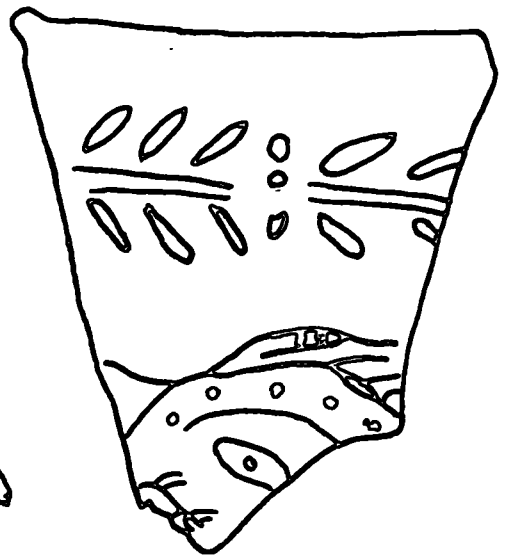

Chesters

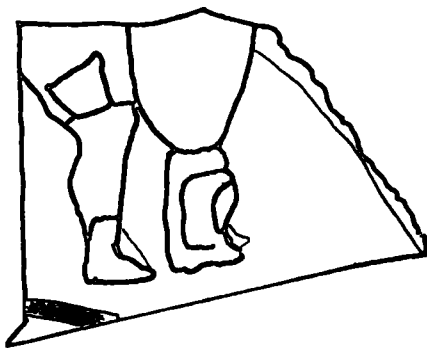

Vindolanda

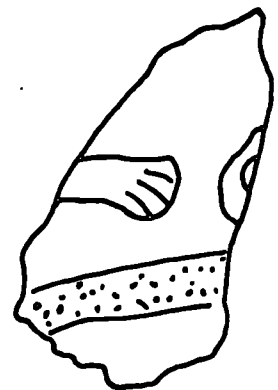

Housesteads  
Fort

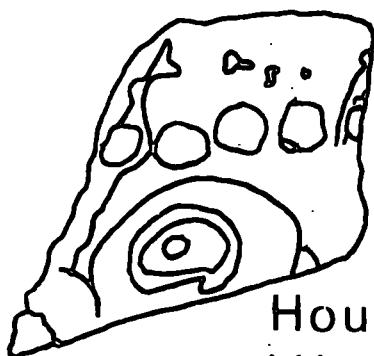

Housesteads  
Vicus

scale 2/1

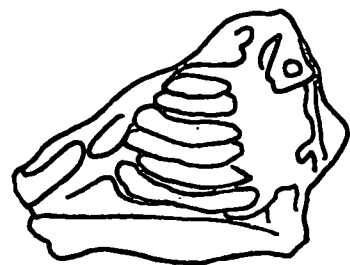

Traprain  
Law

79b

PLATE IX.

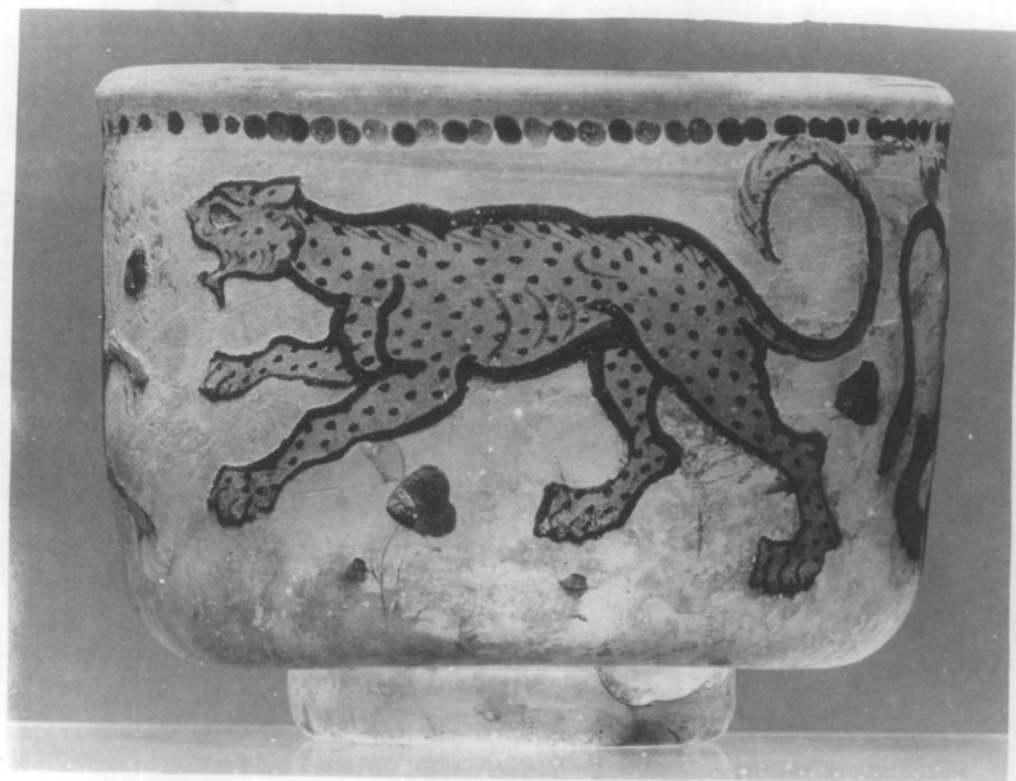

A Painted Glass Bowl  
from Nordrup, Denmark.  
(The National Museum, Copenhagen.)

79c

PLATE X.

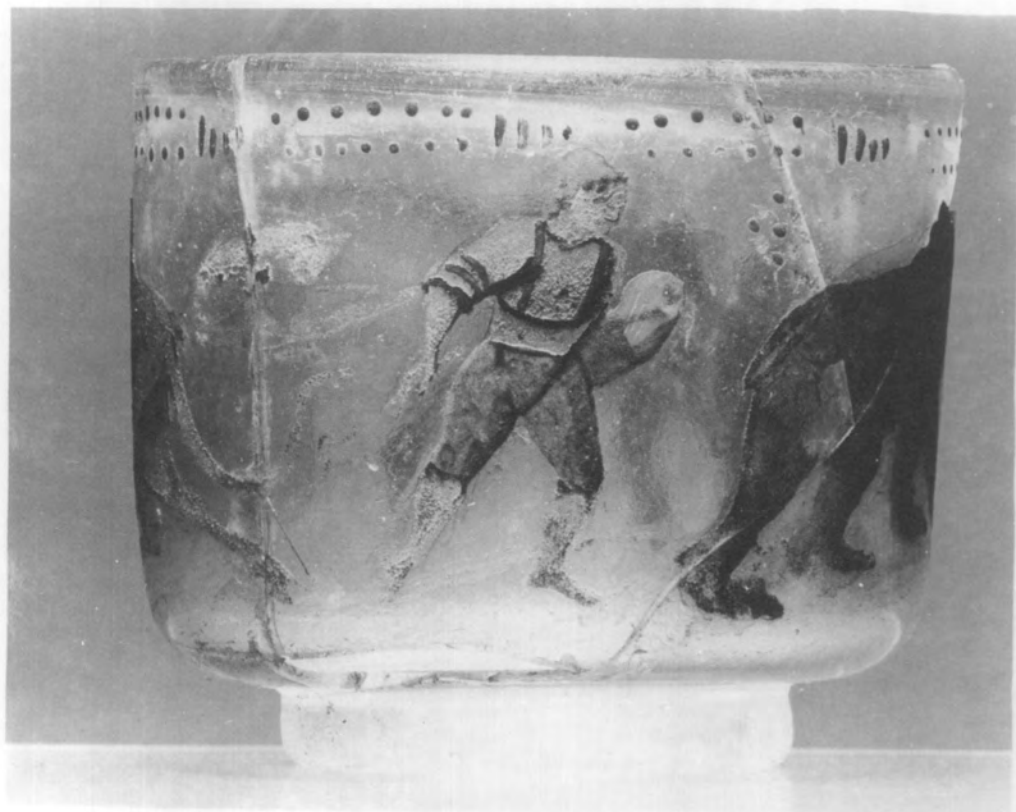

A Painted Glass Bowl  
from Himmlingøje, Sjaelland, Denmark.  
(The National Museum, Copenhagen.)

or bribes, to the native leaders to promote peaceful relations. The bright colours of the paintings and the elaborate decorations would appeal to the native tastes. The bowls would be amongst their owners' most valued possessions, and as such they became part of their grave furnishings. The military commanders may have had the task of distributing these gifts and this is a possible explanation for the broken fragments which have been found in forts on the North British frontier. Alternatively they may have been the property of the officers themselves.

These highly decorative bowls were probably produced in the glasshouses in Germany. The similarity of the known examples would lead one to suppose that they were all produced within the same small area, if not in the same glass works. It would, however, be wrong to assume that they were all the work of one man, since there are differences in the artistic detail. For example, one of the Danish bowls from Nordrup has a dark outline around the animals, a feature not found on the Corbridge or Housesteads leopards.

It is difficult to give any definite date to these bowls. Some authorities suggest that they are contemporaneous, whilst others argue that some were produced around A.D. 200 and others at a much later date.

.....

### Type 32. Cut Glass Bowls.

#### Figure 9. (32a) and (32b) York (reconstructed).

These were very decorative and expensive glass vessels which were produced throughout most of the Roman period. The characteristic feature was the cut designs on the walls and bases of the bowls. Shapes varied, although a cylindrical form of vessel was most common. The cut designs also vary considerably and it is possible to identify early and late specimens. The first vessels of this type were produced in Alexandria, but in the third century they were also being produced by the glasshouses on the Rhine.

These vessels were made of good quality colourless glass.

A number of fragments of bowls of this type have been found at Corbridge, including part of an early Egyptian example, but by far the most impressive collection of Roman cut glass in the North of Britain was

found at York. A number of very elaborate and decorative bowls have been found, generally the later type, which could have come to the wealthy provincial capital from Germany. Unfortunately no exact provenance is known for the majority of the York examples, but they are easily recognisable and dateable to the third or fourth centuries.

Suggested date: A.D. 70-380.

.....

NOTE 4.

Bowls with Engraved Christian Symbols and Figures.

On a few sites in North Britain and on a number of sites in South Britain and on the Continent, fragments of bowls have been found on which are engraved fishes, palm branches and letters. These bowls, of which regrettably no complete specimen survives, are almost certainly Christian objects, since the fish and the palm branch are recognisable Christian symbols. Fragments are known from Corbridge and Chesters in North Britain, Silchester, and several sites along the frontier in Germany. Unlike the painted bowls, however, these vessels are not found outside the Empire. They were probably produced in the glasshouses on the Rhine, all in the same workshop. The historical context in which the German examples were found indicates that these bowls were in use in the early third century, although they had ceased to be made by A.D. 250. This means that the vessels are particularly interesting as evidence for Christianity in the limits of the Empire over half a century before it became the official religion of the Empire in A.D. 313.

Also of note are some pieces of bowls with engraved figures on them, found in North Britain. At Chesters, a particularly fine fragment was found, on which is part of the figure of a man on horseback, with a spear in his right hand. This is similar to a bowl with engraved hunting scenes on it, found at Winthill in Somerset. Fragments of three other engraved bowls have been found in North Britain. A second fragment is known from Chesters. There is one from Traprain Law on which is engraved a head and several decorative details. This is similar to the larger fragment from Dorchester, on part of which a Bacchic scene is engraved. There is also a fragment from Castlesteads which, it is suggested, belongs to a bowl similar to one from Leuna, now in the British Museum. The engravings on these bowls, it is thought, depict the encounter of Actaeon with Artemis, who changed him into a stag.

Engraved bowls were probably made in the fourth century. Dr. Fremersdorf argues that they were products of the German glasshouses on the Rhine, but there is evidence for bowls of this type having been found in the East, notably in Greece, where examples have been found with Greek letters added to them.

GLASS FRAGMENTS WITH  
ENGRAVED  
CHRISTIAN SYMBOLS.

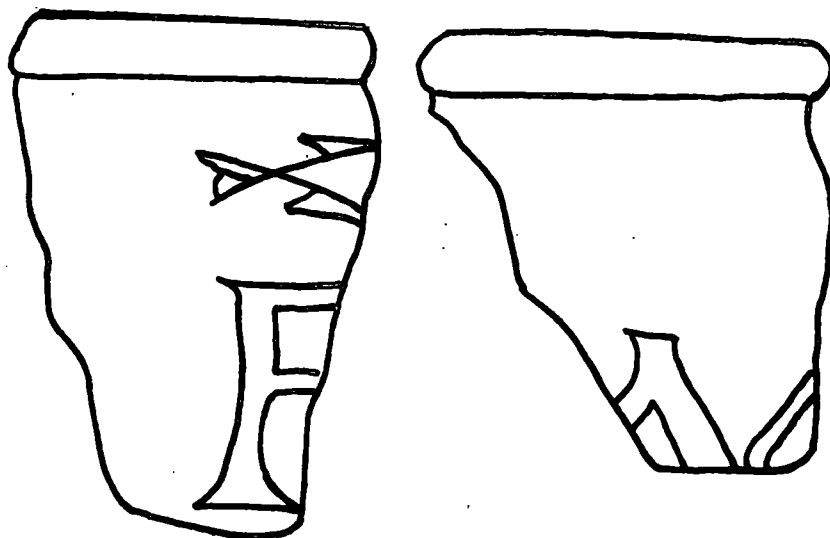

Corbridge

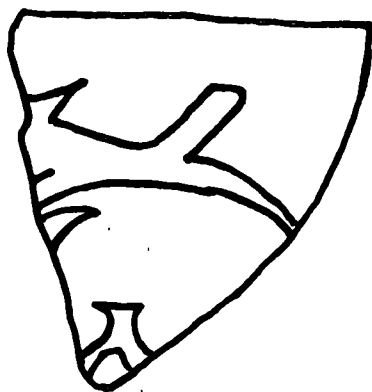

Chesters

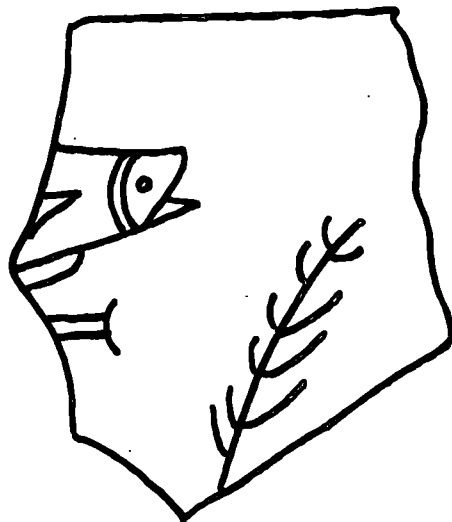

Silchester

GLASS FRAGMENTS WITH  
ENGRAVED FIGURES.1.



Chesters

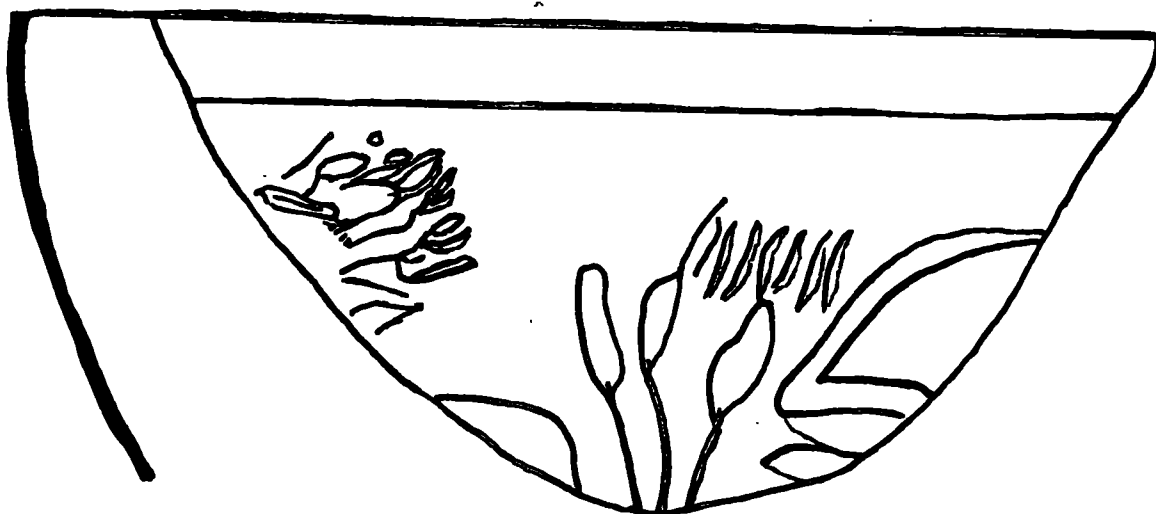

scale<sup>2</sup>/<sub>1</sub>

GLASS FRAGMENTS WITH  
ENGRAVED FIGURES. 2.

Traprain  
Law

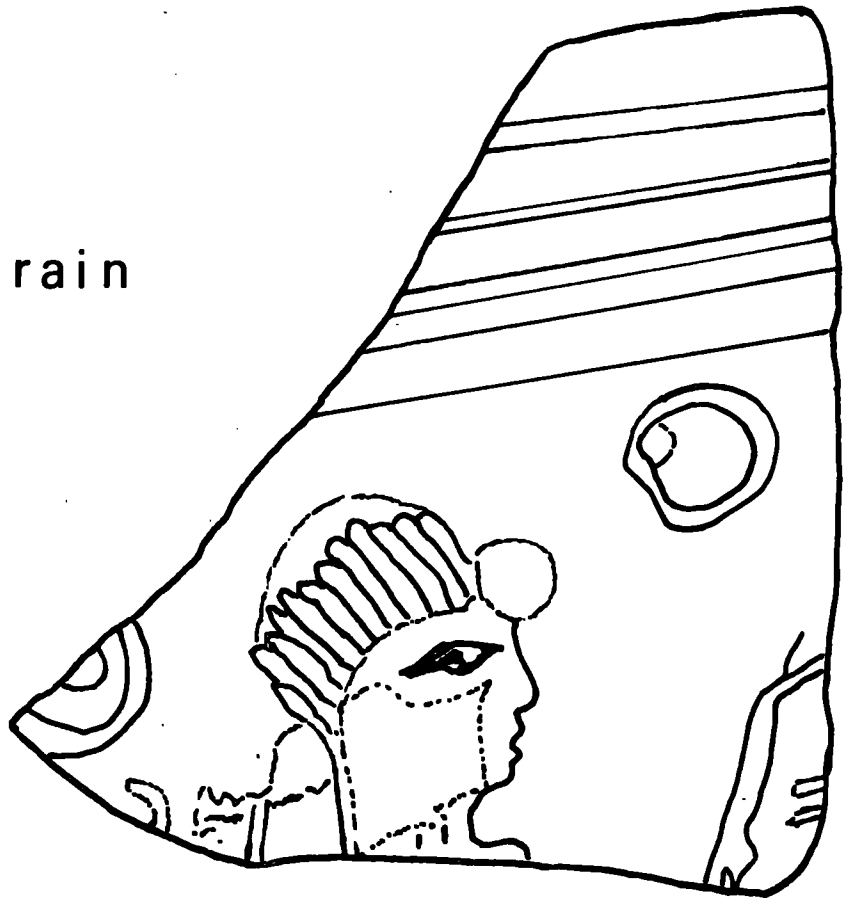

Castlesteads

scale  $\frac{2}{1}$

This, together with the classical context of the stories depicted, may indicate that they were products of the Middle Eastern glasshouses, and it was from the Middle East that they were imported into Britain as expensive luxury wares.

.....

Type 33. Bowl with Tubular Rim.

Figure 9. (33) Corbridge (reconstructed).

Bowls of this type, with their distinctive tubular rims, are found frequently on Roman sites. They vary considerably in size. Some were very small and they may have contained expensive perfume or oil, whilst other larger ones probably had everyday household uses. These bowls are hemispherical in shape, and in addition to the tubular rim they usually have a distinctive tubular footring. They are found frequently on sites throughout the Empire, and it appears that they were produced extensively.

Examples have been found in colourless and almost colourless glass but the majority were made of natural tinted pale blue and green glass.

Fragments of the rims of at least two vessels of this type have been found at Corbridge and parallels can be cited from Newstead and Malton. Excavations on some native sites in Scotland have yielded glass fragments which may be from bowls of this type. The sites include Everley Brock, Caithness; Dun Mor Vaul, Tiree; and Kingolundrum near Airlie, Angus. In the South of England examples can be cited from Richborough and Colchester.

These bowls were first produced in the middle of the first century and they remained in use until the end of the second century.

Suggested date: A.D. 70-200.

See also: Isings Form 44.

.....

Type 34. Pillar-moulded Bowl.

Figure 9. (34) Colchester.

These bowls vary considerably in diameter and height. They are found

very frequently on early Roman sites, but the point should be made that the vessels are very distinctive and easily recognisable. The ribs on the sides of these bowls usually reach the base, tapering as they do so, although some bowls have short ribs just on the sides. They were mould-made and then polished to give smooth inner and outer surfaces. They originated in Egypt but were also produced in large quantities in the North Italian glasshouses. It is the Continental specimens which reached Britain.

The earliest bowls of this type were made of millefiori glass and other polychrome wares, but later good quality monochrome and natural tinted glass was used.

Several fragments of bowls of this type have been found at Corbridge. The majority of these are of natural tinted pale-green glass, although there is also part of a blue and white example. The majority of early sites in the north of Britain appear to have yielded fragments of vessels of this type, and examples can be noted from Newstead, York and Malton. In the south of Britain many examples are known in both coloured and natural tinted glass. One of the most attractive specimens to be found in Britain is a pillar-moulded bowl, from Radnage in Buckinghamshire, which was found in a cemetery. It is made of blue and white "murrine" glass, and it can be seen in the British Museum. Other plainer examples of vessels of this type have been found at Richborough, Colchester, Wroxeter, Lincoln, Exeter, Caerleon, Gellygaer, Pen Llystyn and Whitchurch.

These bowls were a product of the Alexandrian glasshouses and this type is particularly important because it is one of the few which can be closely dated. These vessels were particularly popular during the first century, but the type died out in the opening years of the second century. Nearly all the examples found at Corbridge were in stratified deposits and, with the exception of one small fragment which was probably a rubbish survival, they can all be dated to the Flavian period. It is also noteworthy that no

83a

PLATE XIV.



A Pillar-Moulded Bowl in Amber Glass.

(Guilbenkian Museum, Durham - on loan

from Penrith Museum.)

vessels of this type have been found on sites which were first occupied under Hadrian.

Suggested date: A.D. 70-110.

See also: M.J. Form 68. Isings Form 3.

.....

Type 35. Shallow Plate on Footstand.

Figure 9. (35) Kirkby Thore (reconstructed).

These plates are fairly small in size. They were not mass produced, but they were carefully made in moulds and then polished on a lapidary's wheel. The footstand is short and small in diameter compared with the diameter of the plate, which is very shallow and has a small turned over rim. It has been suggested that plates of this type, with carefully finished rims overhanging at the tip, were probably made in Alexandria, since examples have been found at Karanis, whilst those with a similar rim but no overhang are probably western copies.

The plates were usually made of good quality glass which was either deliberately coloured in shades of red, green and blue, or the glass was colourless.

They are represented in the Corbridge collection by fragments of at least four vessels, but the most interesting example from a site in North Britain was found at Kirkby Thore in Westmorland. It is made of fine emerald green glass and was probably produced on the Continent. It is almost complete and is now in the Tullie House Museum, Carlisle. Other examples are known from Birrens, Cadder, Castlecary, Aldborough and Ditchly Villa.

These plates can be fairly closely dated to the Flavian-Trajanic period. Nearly all the examples found in the north of Britain are from early sites and none are known from sites which were first occupied in Hadrian's reign. The techniques employed in the production of these fine vessels, together

with the colour and quality of the glass, also indicate the early date.

Suggested date: A.D. 70-120.

See also: M.J. Form 91. Isings Form 5.

\* \* \* \* \*

FIGURES

TO ILLUSTRATE SECTION III.

FIGURE 1.

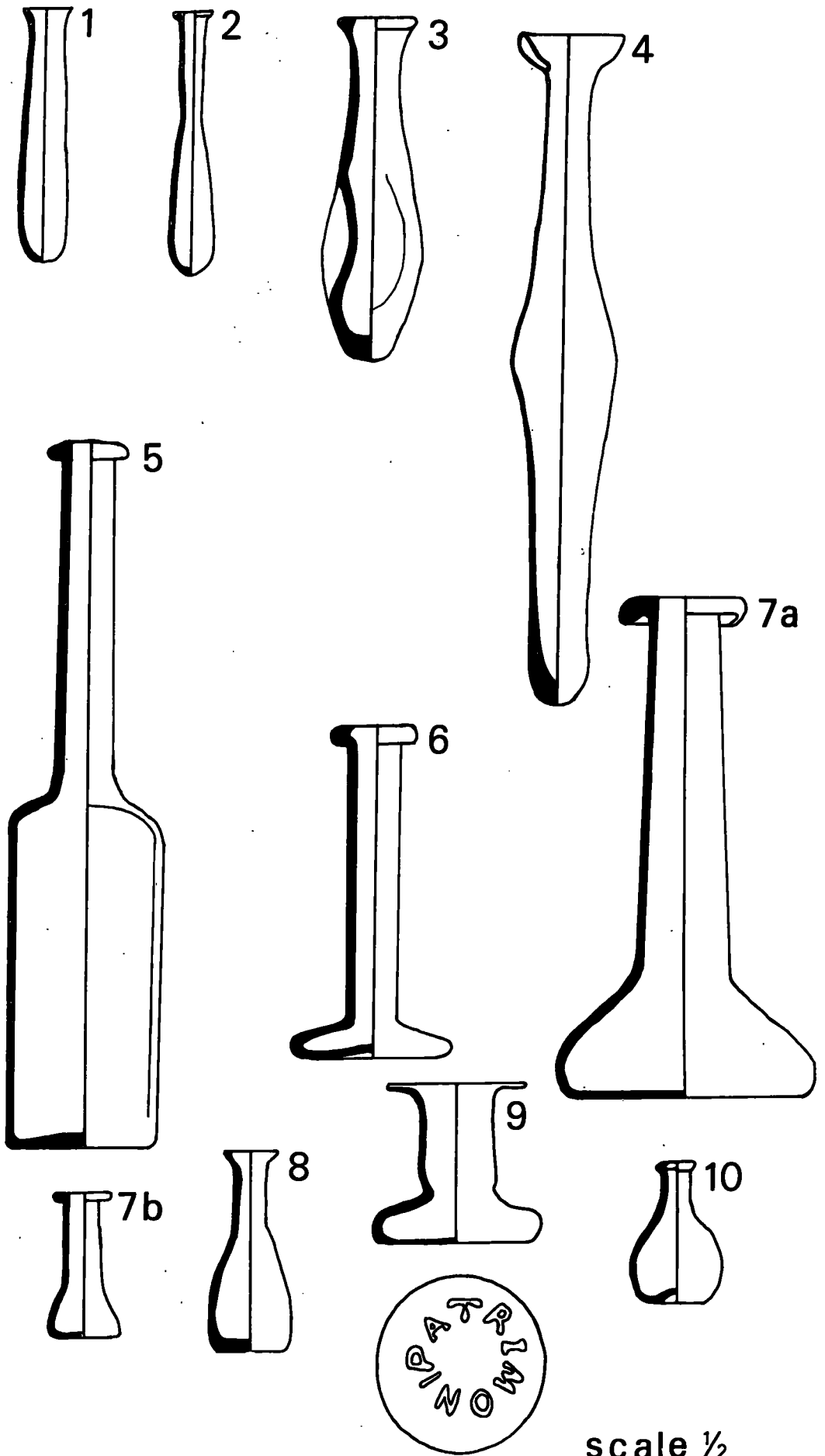

scale 1/2

FIGURE 2.

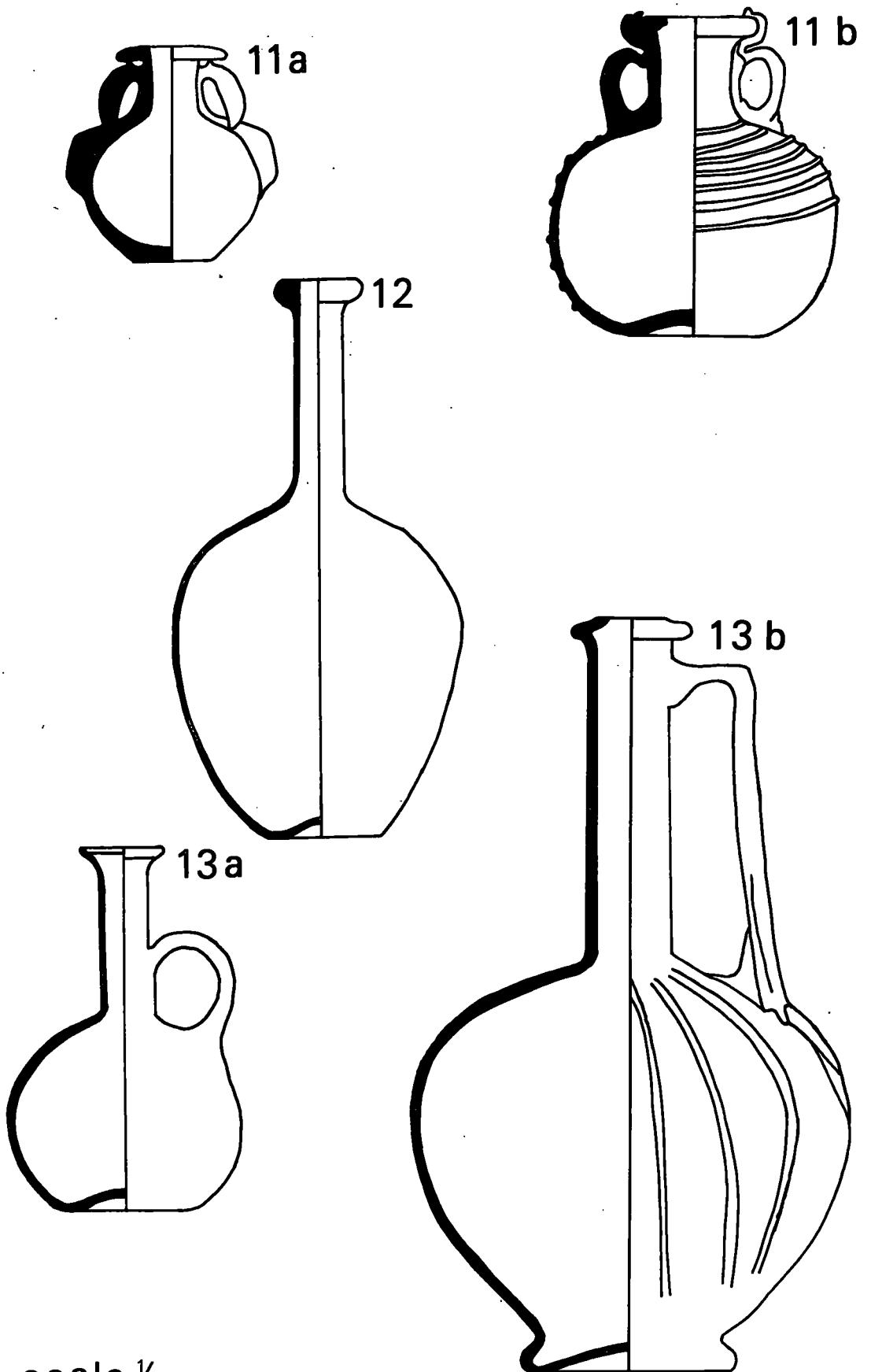

scale 1/2

FIGURE 3.

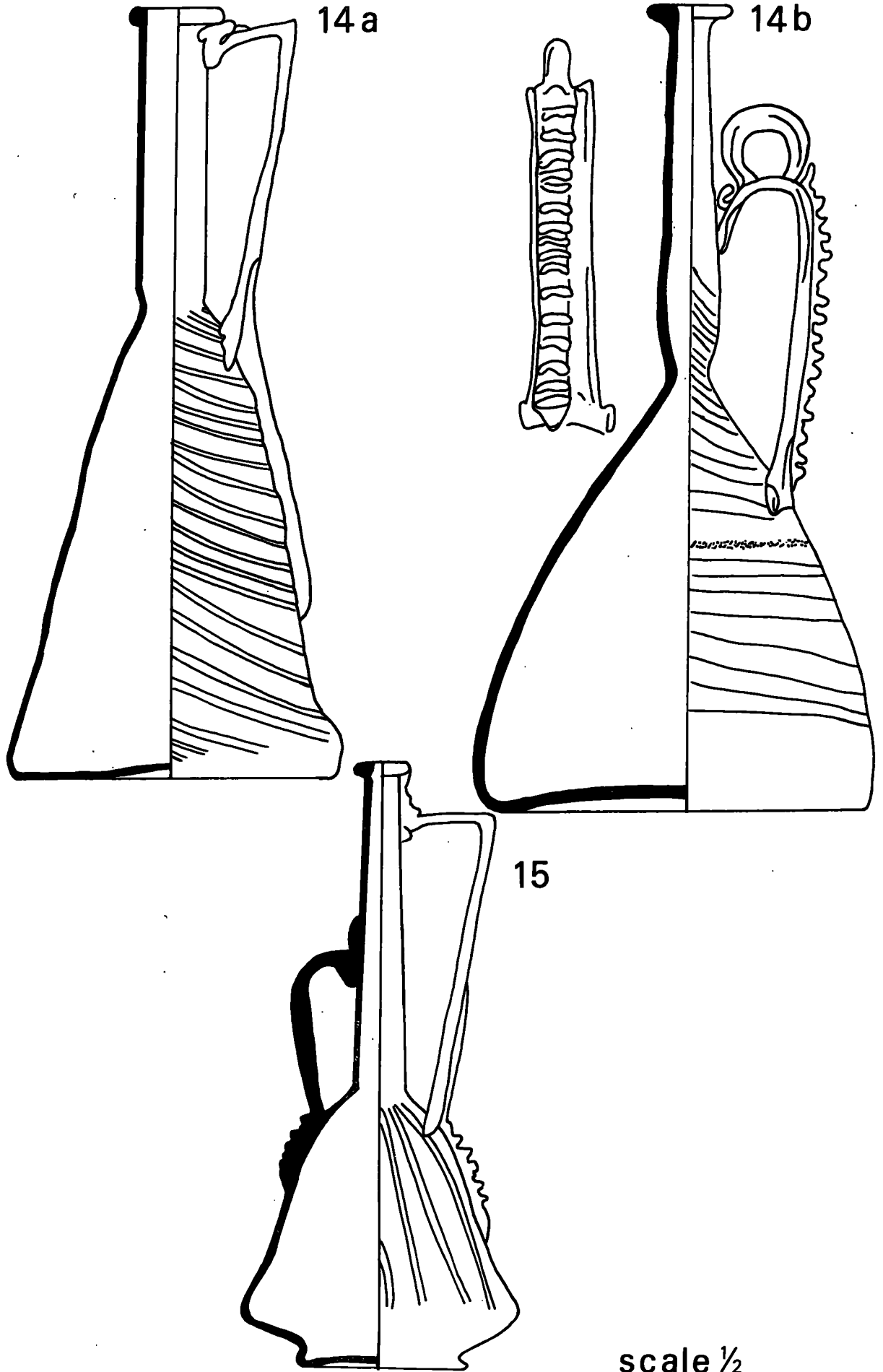
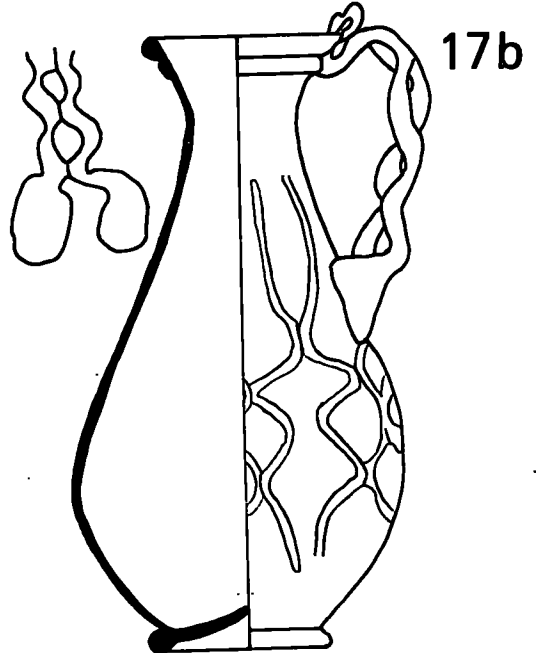
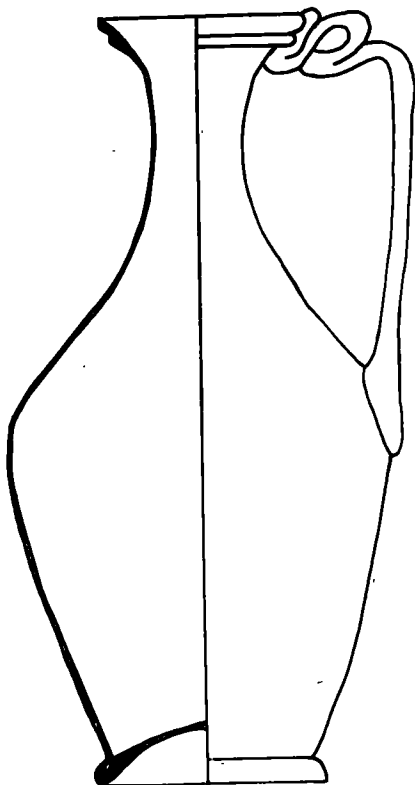
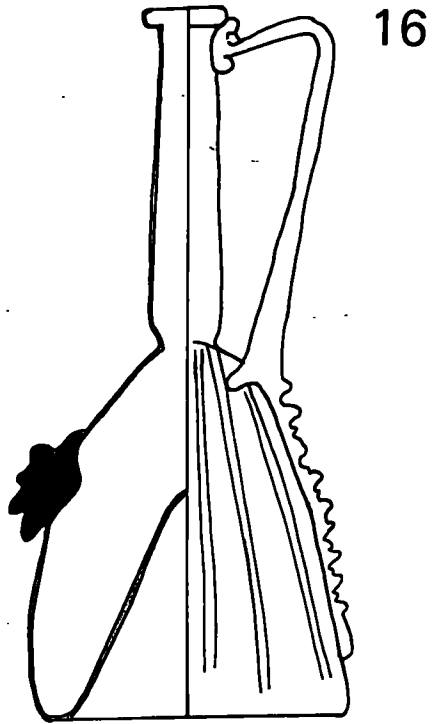
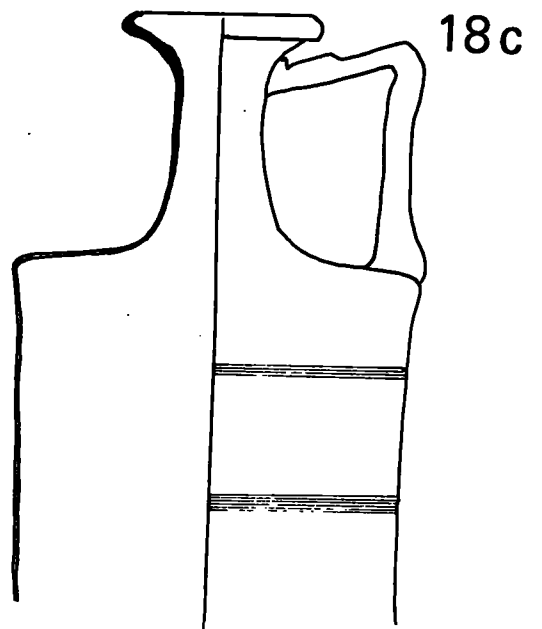
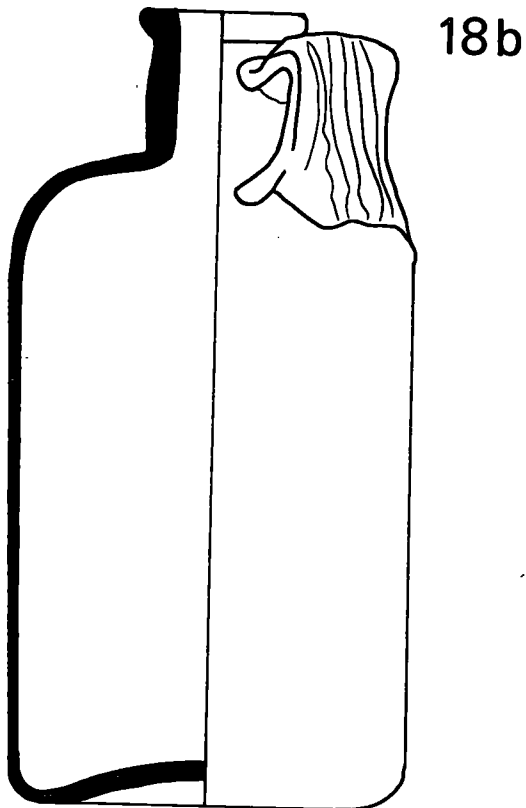
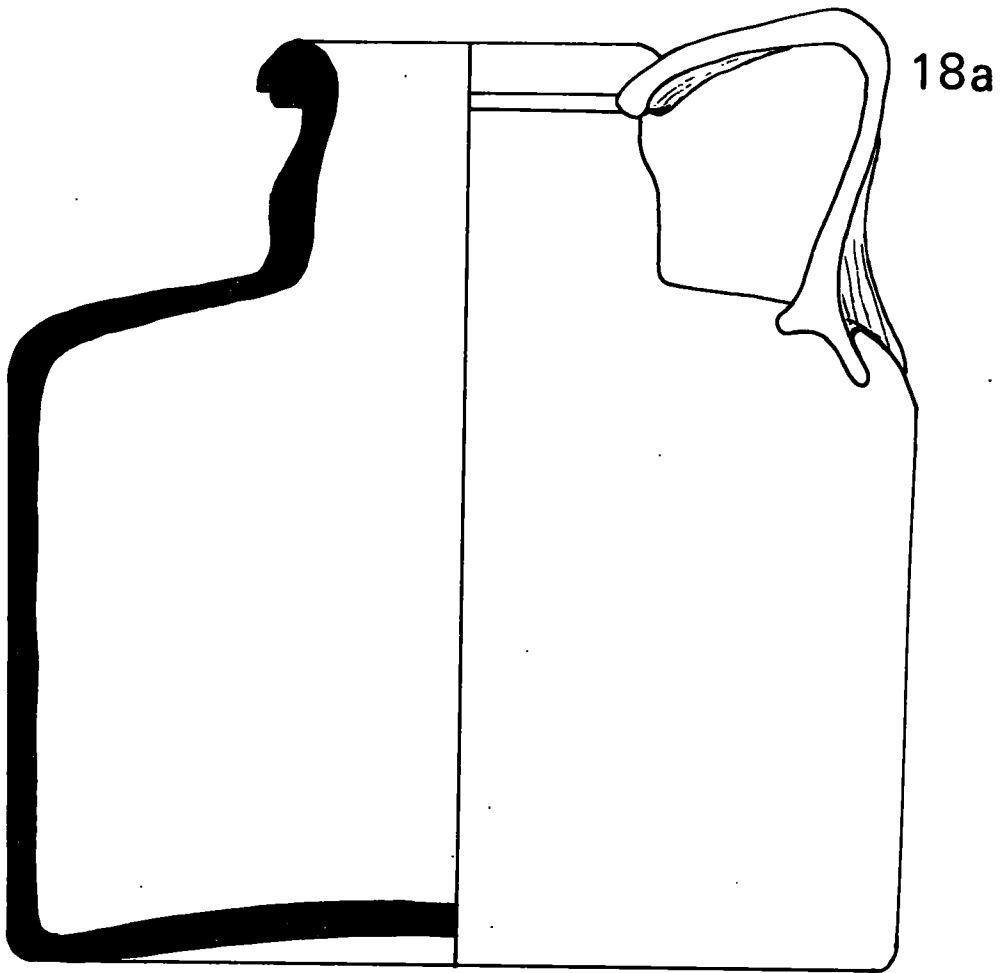

FIGURE 4.



scale  $\frac{1}{2}$

FIGURE 5.



scale 1/2

FIGURE 6.

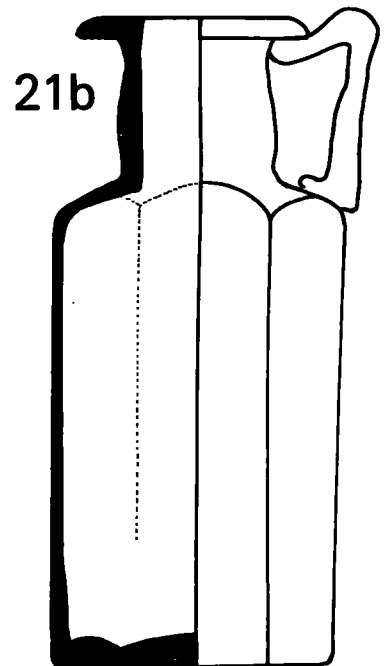
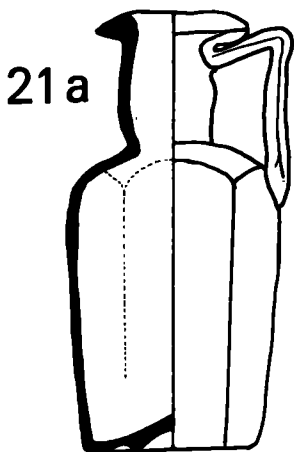
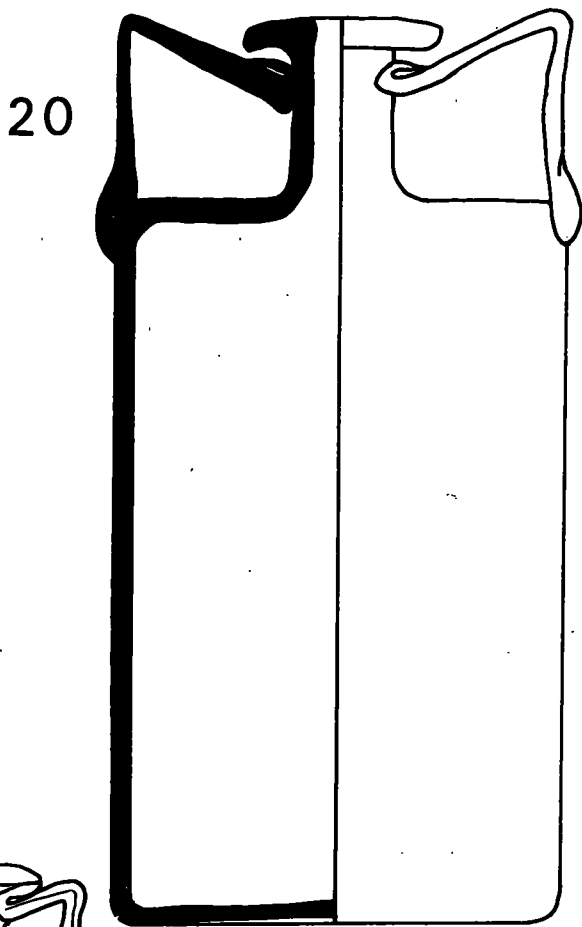
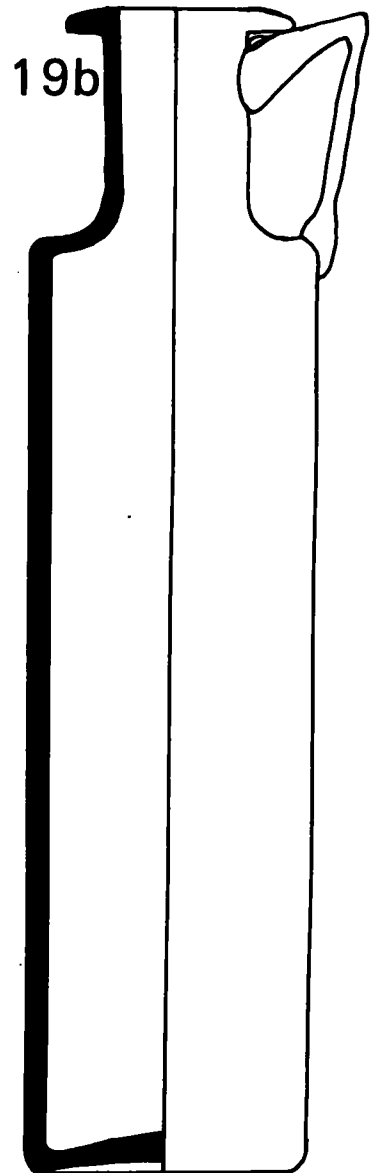
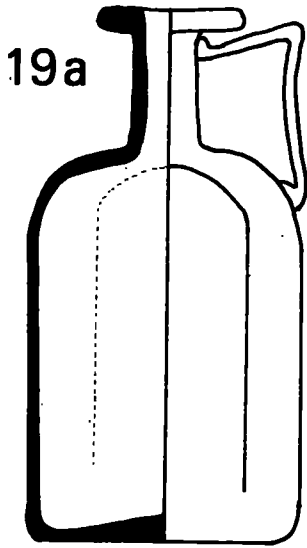

scale 1/2

FIGURE 7.

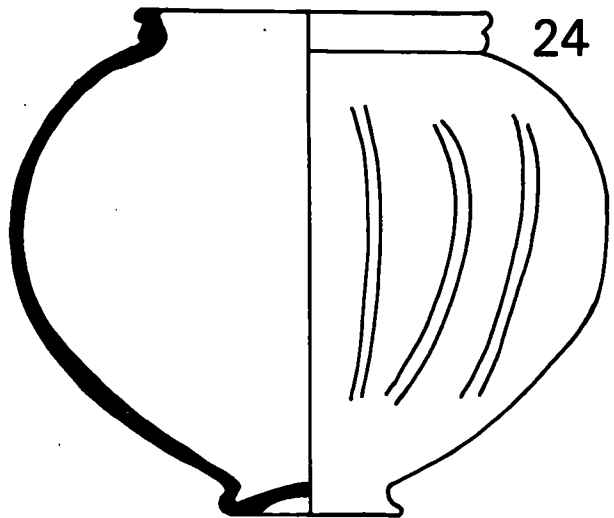
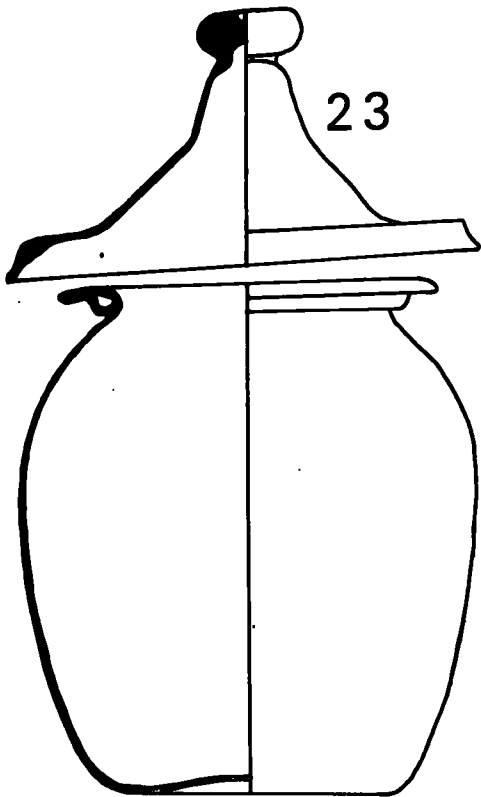
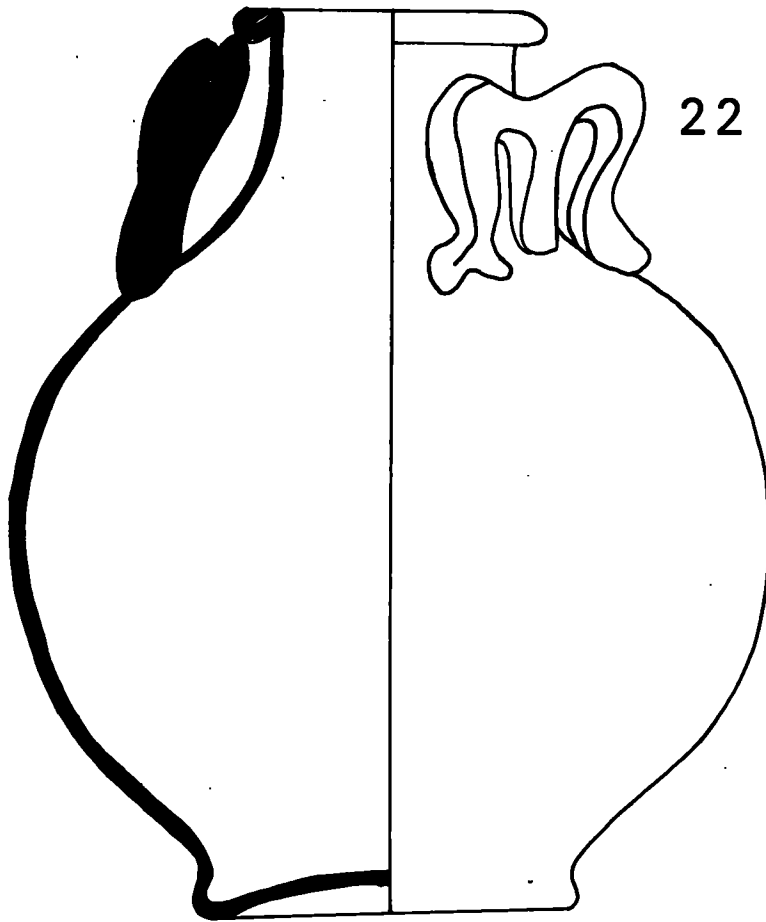

scale 1/2

FIGURE 8.

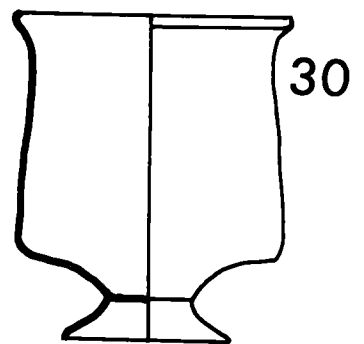
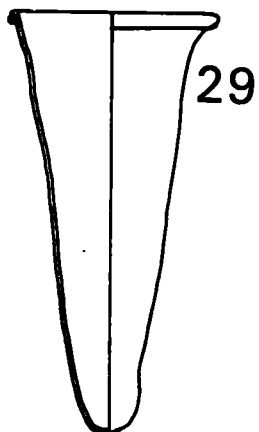
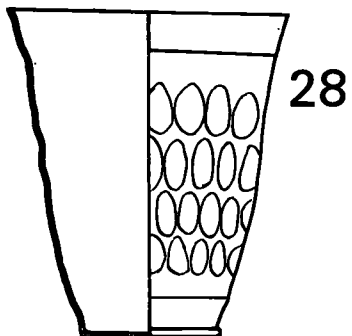
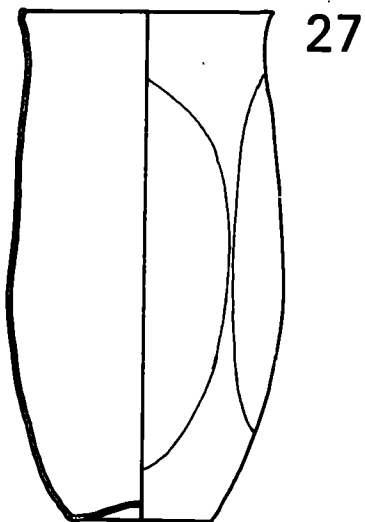
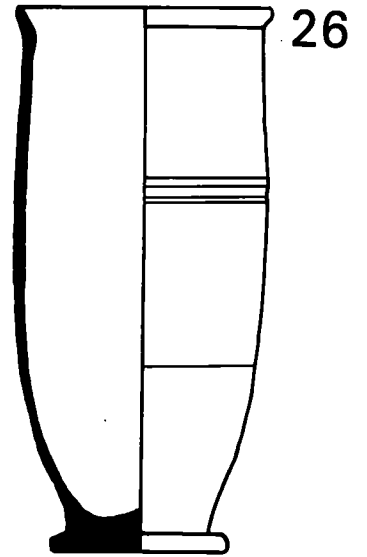
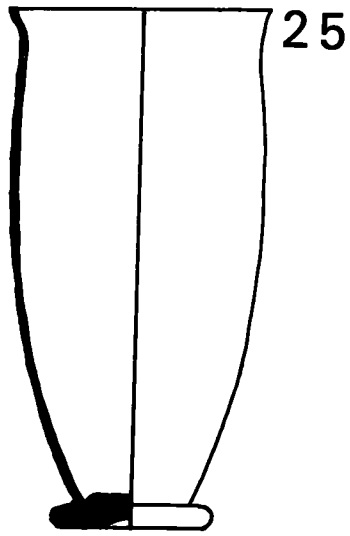

scale  $\frac{1}{2}$

FIGURE 9.

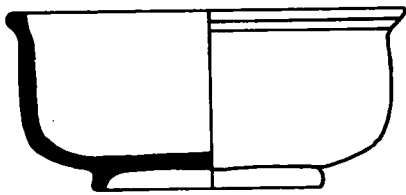

31a



31b

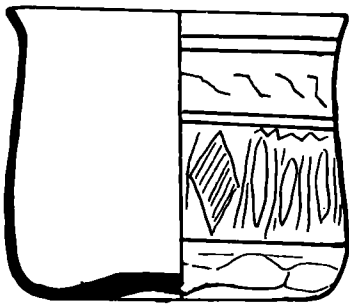

32a

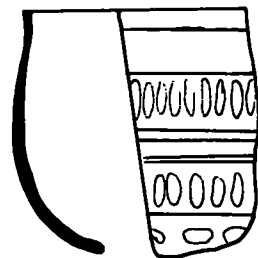

32b

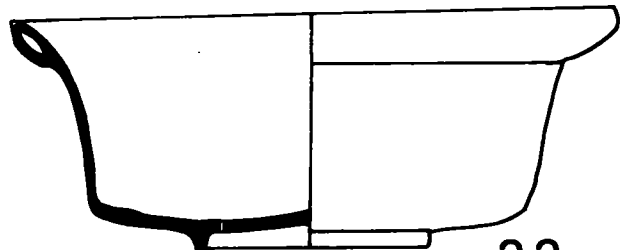

33

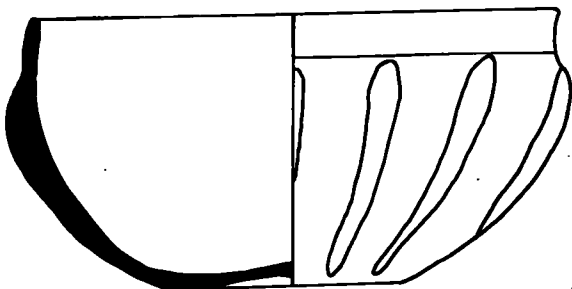

34

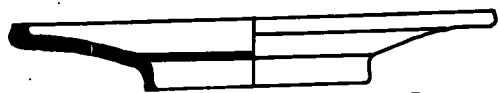

35

scale 1/2

APPENDICES

1. SNAKE THREAD GLASS.
2. THE WEATHERING OF GLASS.
3. A REPORT ON THE ROMAN GLASS FROM MALTON.

APPENDIX 1.Snake Thread Glass.

In the course of the foregoing survey of types of glass vessels, reference has been made to several decorative techniques. Some of these have been dealt with in detail but the survey would be incomplete without consideration of one specific decoration which is sufficiently distinctive in itself to be of importance when it is found on fragments which cannot be assigned to any definite type of vessel.

A fairly common decoration on Roman glass vessels takes the form of strips of coloured glass trailed on to the walls of the vessel. One particular form of trailed decoration is very distinctive and it is particularly important because it is a style which was popular during a limited period. This means that fragments can be closely dated and the glass can act as a "tracer element". This decoration consists of trails of glass, usually white, blue or yellow, which have short lines scored across them. These trails often resemble snakes. Hence the style is called Snake Thread Glass. This form of decoration was applied to several types of vessel: bottles, jugs, dishes and beakers.

Several examples of this decorative style have been found in North Britain. In only one case is it possible to identify with any certainty the form of vessel from which the fragment came. The piece is part of the base and walls of a small stemmed beaker, with snake thread decoration, found at Aldborough. Part of a similar vessel, also with trailed decoration, was found at Silchester. Other fragments of snake thread glass from North Britain come from York, Piercebridge and South Shields.

This style of decoration was particularly popular during the late second and early third centuries. The vessels upon which it was used were probably produced in the glasshouses of the Rhineland.

# FRAGMENTS OF SNAKE THREAD GLASS.

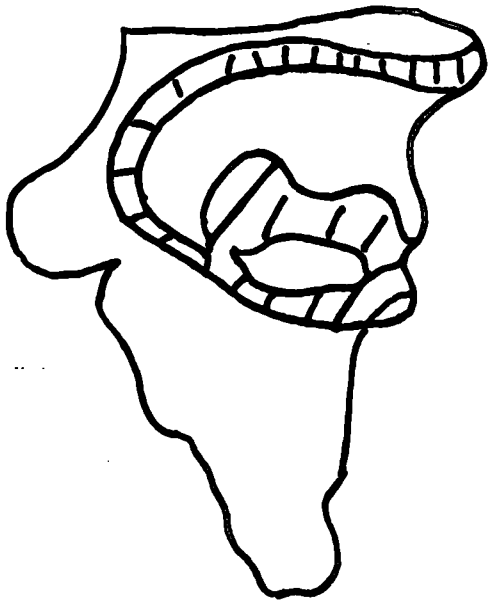

York

Piercebridge

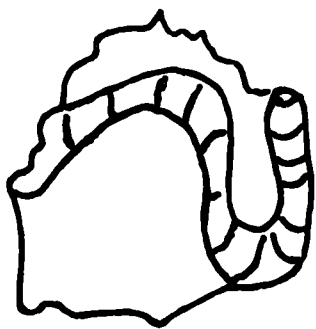
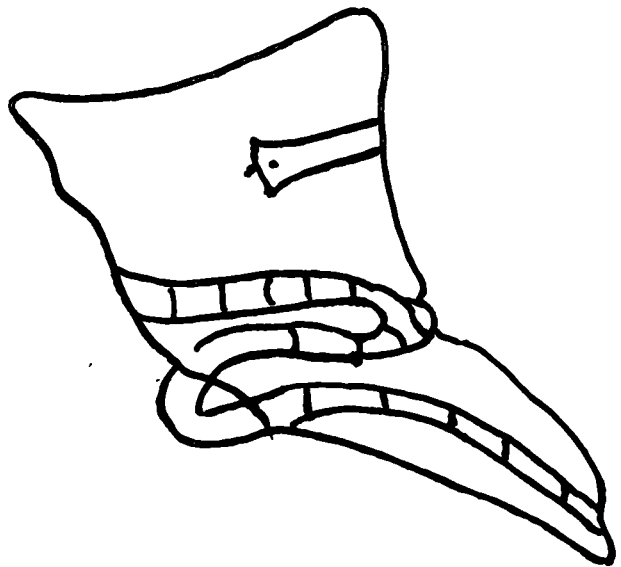

South  
Shields

APPENDIX 2.The Weathering of Glass.

The condition of the glass found on different sites varies considerably. In some cases it appears to have undergone very little or no change at all during the centuries it has been in the ground, whilst in others the condition of the glass has deteriorated considerably and it is sometimes difficult to decide exactly what the original metal was like. The term used to describe this change is weathering and it covers a wide range of phenomena.

One of the most common forms of weathering is iridescence, which is particularly interesting because, like the patina on bronze, it often enhances the appearance of the vessels, making them of considerable value for collectors. Iridescence is caused when the glass is lying in damp soil or is exposed to a humid atmosphere over a very long period of time. The carbon dioxide in the atmosphere dissolves in the moisture in the soil or air and forms carbonic acid, which reacts with the alkali in the glass itself and causes a gradual decomposition of the surface. This decomposition is first visible in the form of filmy patches on the surface of the glass. It then becomes shiny and it reflects light, producing a rainbow-like effect, and gradually, if the deterioration is allowed to continue, a thick eroded layer is formed which finally flakes off. In its most virulent form this weathering process can cause the vessel to disintegrate, although deterioration to this extent is very rare. Iridescence can be found on all types of glass, and it is interesting that the different colours reflected by the iridescence are to some extent controlled by the original colour of the glass itself.

Another form of weathering is devitrification. This is different from iridescence because it is the result of a physical change of state of the glass metal, and is not the result of external phenomena reacting

upon it. In its mild form, devitrification may appear as slight cracks on the surface of the glass resembling frost on a window, whilst in its serious form a number of small cracks appear running through the glass in all directions. This gives the vessel a sugary appearance and gradually the crystals separate and the vessel disintegrates. This can be caused simply by the working off of internal strains within the glass. It may be the result of the vessel's having been cooled too quickly when it was made. Unless glass is cooled very slowly the exterior of the walls contracts more quickly than the interior and this produces a variation in strain which in the course of time produces the cracks.

A third and much less common form of weathering than either of those previously discussed is milky or enamel-like weathering. This takes the form of an opaque white, or occasionally brown or black substance appearing on the surface of the glass. The surface is gradually eaten away by this substance and the wall of the vessel may become pitted as the surface flakes off. The exact cause of this process is uncertain, although it appears that, like iridescence, it is the result of a chemical change as the alkali in the glass reacts with chemicals in the soil.

.....

APPENDIX 3.A Report on the Roman Glass from Malton.

This report was written about the material found during excavations at Malton, completed in 1970. It is included in this appendix in its entirety, as submitted to Mr.L.P.Wenham, direction of the excavation, for inclusion in his final excavation report.

\* \* \* \* \*

The amount of glass found at Malton was comparatively small and most of what was found was very fragmentary. This fact is not surprising since the site at Malton was an occupied site and complete vessels, or large fragments which can be reconstructed, are rarely found on occupied sites. Complete vessels, which provide most of the information which we have about glass during the Roman occupation of Britain, come chiefly from cemetery sites in which glass vessels were either used as cinerary urns or were buried in the grave with the body.

Several fragments of glass from Malton have no shaping or any distinctive feature by which the form could be identified, and of those which can be classified only 3 can be reconstructed sufficiently to enable a drawing of the vessel to be made. Altogether 40 fragments of 32 vessels can be identified and these can be divided into 6 main types, under which they will be considered. There are also a few fragments of individual vessels which deserve special consideration.

Window glass will also be considered together with pieces of four glass bangles.

PILLAR MOULDED BOWLS.

These vessels, which were mould-pressed, were in use in the first century, and they appear to have gone out of production at the beginning of the second century with the growing popularity of blown glass. Fragments of them are common on sites in Britain, although the point should be made

that these vessels are very distinctive and consequently it is easy to recognise even the smallest fragments, whilst other less distinctive forms of vessel may have been equally common, but because they are not always recognisable their forms are neglected.

Fragments of two vessels of this form were found at Malton although neither was large enough to give any impression of the size or shape of the vessel in question.

- (1) Part of the wall of a bowl of pale green glass.
- (2) Fragment of the wall of a vessel of almost colourless glass with a slight blue tint.

BULBOUS JAR WITH RIBBED BODY. (Fig. 1.)

Large glass jars appear to have been in regular domestic use during the Roman occupation of Britain, and they had a secondary function as cinerary urns.

- (3) A number of fragments of a ribbed jar were found at Malton. Unfortunately the fragments were not conjoining and they did not include parts of either the rim or the base; consequently the exact shape cannot be recognised. This vessel was made of good quality deep blue glass.

BEAKERS.

Domestic cups or beakers were common during the Roman period. There were, however, considerable variations in shape and metal.

A number of specimens were found at Malton, of several different types; it is interesting that the majority of the fragments are of fine colourless glass, rather than the natural green-coloured glass which was the more common metal.

- (4) Fragment of the rim and wall of a straight-sided beaker of fine metal with a pale blue tint. Diameter 3 ins. (7.5 cms.)
- (5) Fragment of the rim and wall of a beaker of pale blue metal. Diameter 4 ins. (10 cms.)

- (6) Fragment of rim and wall of a beaker of good quality colourless white metal. Diameter 4 ins. (10 cms.)
- \* (7) Wall fragment of a beaker decorated with wheel incised lines, and made of almost colourless glass with a green tint in the break.
- \* (8) Fragment of a similar vessel of finer colourless metal.
- \* These vessels are common on Roman sites and a complete example from a cemetery can be seen in the Yorkshire Museum, York.
- (9) Fragment of the rim and wall of a small beaker with fine trailed decoration. The rim of this vessel was badly finished. It was made of colourless metal with a large number of bubbles. Diameter 2 ins. (5 cms.)
- (10) Wall fragment of a beaker with indented sides of fine, almost colourless metal with a pale green tint. The metal has many flaws and there is evidence of the polishing of the vessel on the outside.
- (11) Three fragments of a fine polished cup, the exact shape of which cannot be decided. The metal is fine and contains many bubbles and flaws.
- (12) Two fragments of a similar vessel, although the shape is rather uncertain. This glass has weathered rather badly and it appears that it was poor-quality pale green glass.
- (13) Fragment of the footring of a beaker of pale green glass. Diameter 4 ins. (10 cms.)
- (14) Fragment of the footring of a beaker of white glass. Diameter 3 ins. (7.5 cms.)

#### DISHES.

Like beakers, bowls and dishes of various forms occur frequently on

Roman sites. Malton yielded five specimens, two of which are of particular note and these will be given more detailed consideration later.

- (15) Fragment of the base and wall of a small dish, made of fine white glass, with a fine trailed decoration.
- (16) Part of the rim of a large dish, of polished pale green glass.
- (17) Part of the base and wall of a large dish. Base diameter 9 ins. (22.5 cms.) of heavy pale green glass.

#### FLASKS.

Fragments of flasks are common on Roman sites, although the form and size of the vessels varied considerably, probably because these were domestic containers rather than ornamental vessels.

- (18) Fragment of the circular base and wall of a fine flask of colourless glass.
- (19) Part of the base of a colourless flask with moulded circular decoration.
- (20) The circular base of a flask of colourless glass, with a slight 'kick' on the base.
- (21) Fragment of the rim and neck of a flask in brown glass. Rim diameter  $1\frac{3}{4}$  ins. (4 cms.)
- (22) Part of the rim of a flask in heavy pale blue glass. This rim was folded outwards and flattened to give a triangular profile; it comes from a form of flask which was common in the first century. Rim diameter 3 ins. (7 cms.)

#### SQUARE AND RECTANGULAR BOTTLES.

By far the most common glass vessels on sites of the Roman period are

square and rectangular bottles. These vessels were domestic containers which were in use throughout the period, and there were many variations on the basic form in size and decoration. At Malton twelve recognisable fragments of this type of vessel were found, including :

- (23) The base of a square bottle of blue green glass with moulded concentric circles, the most common decoration, and a slight 'kick' in the centre.
- (24) Part of the base and wall of a pale blue square bottle with similar circular moulding.
- (25) A base and wall fragment of a similar vessel in pale green glass, also with circular moulding.
- (26) A base fragment of a square bottle with a 'kick' in the base and a single small moulded circle in the centre.
- (27) Part of the reeded handle of a vessel of this form, in pale green glass.
- (28) Rim fragment of a square, rectangular or cylindrical bottle of pale blue glass.

#### UNGUENTARIUM.

Small perfume bottles (unguentaria) or 'tear-bottles' were common in Roman Britain. They varied considerably in shape and size. At Malton only one recognisable specimen was found.

- (29) Small circular base of unguentarium of almost colourless glass with a slight green tint. Only part of the base, which had a diameter of 0.6 ins. (1.6 cms.) was found, and it was not possible from this to decide the actual form of the vessel. This fragment is particularly interesting because it

appears that it had been trimmed after it had been broken, for use as a gaming counter, in the same way that fragments of samian were often shaped to make gaming counters.

BOWL OF A FORM WHICH IS ALSO FOUND IN SAMIAN POTTERY. (Fig. 2.)

- (30) A fragment of a vessel from Malton, of translucent white glass, is part of a bowl. This vessel is of particular note because its form was the glass predecessor of the samian form Dr. 38. In his discussion of types of Roman glass vessels Morin-Jean mentions this form (M.J. Form 85.), and he states that it occurs throughout the Roman period. In the first century the vessels were mould-pressed, but later a mould-blown type was produced.

BOWL WITH DECORATIVE 'FINS' (Fig. 3.)

- (31) Two small fragments of a decorative bowl of fine white-colourless glass, were found at Malton. These were part of an unusual form of vessel and they were sent to Miss Dorothy Charlesworth, F.S.A., for her expert opinion. Miss Charlesworth dates the vessel to the period from the middle of the third to the middle of the fourth century, and she refers to a similar vessel illustrated by Morin-Jean (p.228 fig.310.) from Neuville-le-Pollet, although she makes the point that the Malton piece is slightly different, since it does not have indents between the 'fins'. She also refers to similar vessels with only slight variations from Colchester, Corbridge and Verulamium.

# ROMAN GLASS FROM MALTON.

## VESSELS

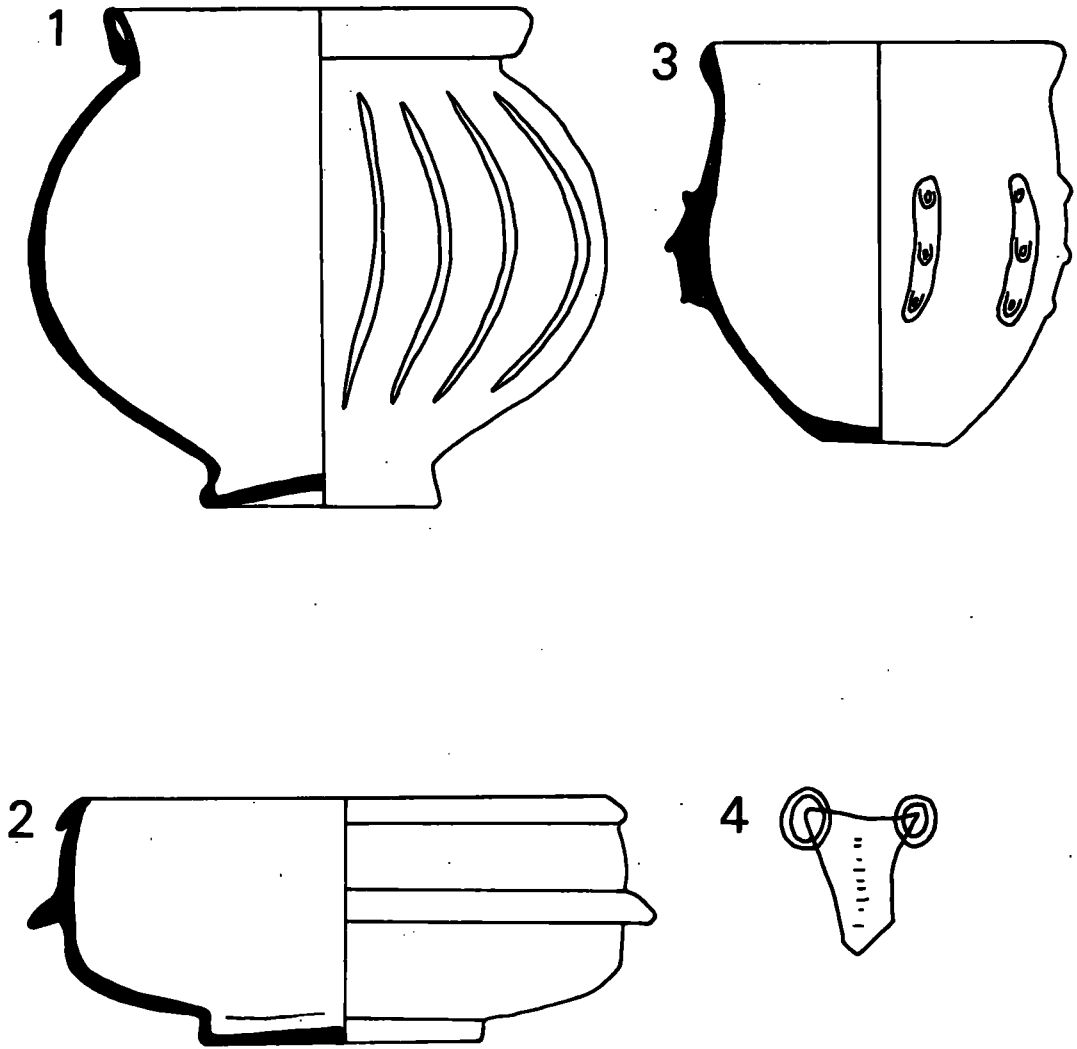

SCALE 1/2

## BANGLES

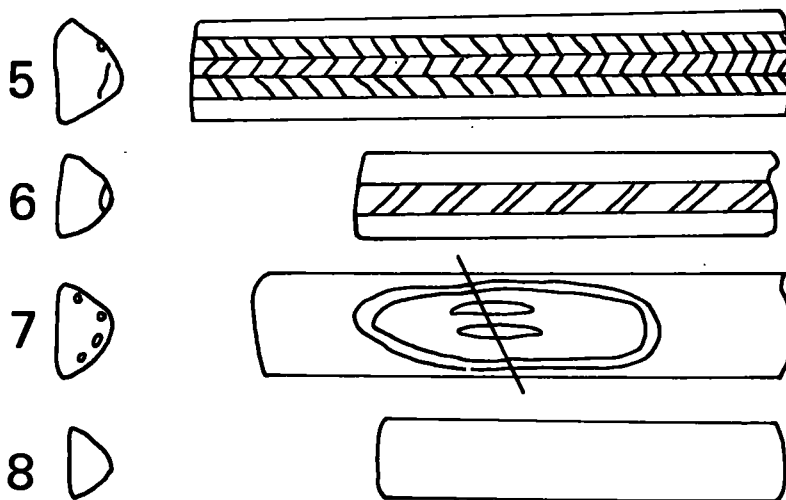

SCALE 1/1

BEAKER WITH TRAILED OR MOULDED DECORATION. (Fig. 4.)

- (32) A small decorated fragment of colourless glass was also sent to Miss Charlesworth for her opinion. She thinks that it is part of a beaker-shaped vessel and that the decoration is probably trailed although the fragment is too small to be certain. She suggests a date of A.D. 150-250 and cites a piece with similar decoration from Verulamium.

WINDOW GLASS.

Only two fragments of window glass were found at Malton, but these deserve discussion since they show a number of interesting features.

- (1) An edge fragment of blue-green glass. The underside is heavily sanded. The natural edge and viscid flow lines are visible.
- (2) A large fragment of transparent pale blue glass. The under side of this piece is not sanded and it has a slight purple iridescence. The bubbles in the structure of the glass appear to show the flow line and there is a convexity on the upper surface.

GLASS ARMLETS OR BANGLES.

Malton excavations yielded four fragments of glass bangles. This type of archaeological material has been the subject of two papers; the first by H.E.Kilbride-Jones (PSAS LXXII 1937-38) and the second by R.B.K.Stevenson (PSAS LXXXVIII 1954-56). These papers both suggest that the bangles were made in the area between the Walls, and the distribution of examples known to Kilbride-Jones limited them largely to the frontier area. Stevenson has increased the distribution by mentioning a few examples further south which, he suggested, reached there by trade. Since these papers were written, examples have been found on sites throughout Britain, and it is now thought

that bangles, like the vast majority of glass in the Roman period, were brought into this country from abroad by traders. The prevalence of them in the north suggests simply that they appealed to the native people of this area, who accepted them in exchange for skins and other goods. The four pieces from Malton increase the number of examples which have been found on sites south of the frontier area and add further weight to this hypothesis.

The largest fragment (Fig. 5.) is part of a bangle of deep blue translucent glass with fine white lines on the edges and three opposed rows of white diagonal hatching on the crest. This bangle is D-shaped in section and it is 3 inches (7.5 cms.) in diameter. This is an example of Kilbride-Jones type 2, and he refers to similar pieces from Traprain Law, Newstead and Manchester.

Another fragment, (Fig. 6.) also of Kilbride-Jones type 2, is of transparent pale blue tinted bottle glass. It is basically D-shaped in section, but a twisted cord of translucent deep blue and white glass has been added to the crest of the bangle. This has not been marvered into the bangle and it is visible in the section. Part of an almost identical bangle has been found at Corbridge, and Kilbride-Jones cites an example from Verulamium. Professor Birley has also told me of an unpublished example of a bangle of this type found during excavations at Fishbourne Palace. This bangle had a diameter of 2 inches (5 cms.)

The third fragment, (Fig. 7.) is of yellowy-green glass with a design of large oval "eyes" of buff glass with light blue and buff "pupils". This appears to be a bangle of Kilbride-Jones type 3.

The fourth piece (Fig. 8.) is part of a bangle of opaque white glass paste. This is the most common type of Roman bangle in Britain and it is Kilbride-Jones type 3A. This is a very small fragment and

consequently it is impossible to give the diameter of the original bangle with any degree of certainty.

\* \* \* \* \*

W. J. H. January 1971.

With acknowledgements to Miss D.Charlesworth,F.S.A., for her opinion on vessels 31 and 32., Mr.W.Dodds for his assistance and for producing the drawings and Professor E.Birley for his help and encouragement.