

Durham E-Theses

*A computer based college record system providing for
record interrogation and data interchange*

D. M. R. Bell

How to cite:

Bell, D. M. R. (1973) A computer based college record system providing for record interrogation and data interchange. Masters thesis, Durham University.

Use policy

The full-text may be used and/or reproduced, and given to third parties in any format or medium, without prior permission or charge, for personal research or study, educational, or not-for-profit purposes provided that:

- a full bibliographic reference is made to the original source
- a <https://etheses.durham.ac.uk/id/eprint/10066/> is made to the metadata record in Durham E-Theses
- the full-text is not changed in any way

The full-text must not be sold in any format or medium without the formal permission of the copyright holders.

Please consult the [full Durham E-Theses policy](#) for further details.

A COMPUTER BASED COLLEGE RECORD SYSTEM
PROVIDING FOR RECORD INTERROGATION
AND DATA INTERCHANGE

Thesis submitted for the Degree of Master
of Science at the University of Durham

D.M.R. BELL, B.Sc.



University of Durham Computer Unit

August 1973

ABSTRACT

In a project to handle the records of students at a College of Education, the author has provided a suite of programmes for an IBM 360/67 computer. These programmes perform the tasks of data management, establishing and maintaining the student records, and providing access to the data files for information retrieval.

In this thesis the author uses this work as the basis for a discussion on Data Management Systems. A report of the College system is included and an account is given of many of the problems involved in the establishment and maintenance of Data Management Systems and in the provision of information retrieval routines. Security measures and the need to protect both the data and those it represents are also discussed, and an outline is given of some of the problems involved in the development of a small data interchange system which the author has designed and implemented as part of the College Data Management System.

ACKNOWLEDGEMENTS

I would like to thank the Principal and the members of the Academic Board of Bede College, Durham, for permitting me to use the College Data Bank for this thesis. I am indebted to the College representatives, Dr. R.F. Smith and Mr. M.T. Taylor, for their assistance throughout the development of the project; and especially to Mrs. O. Adey, the College Records Officer, for her continual help.

I am most grateful for the advice given by members of the College Staff and my colleagues in the University of Durham Computer Unit. I am also indebted to the representatives of the Department of Education and Science at Darlington for their encouragement and assistance with the data interchange system.

I would like to thank Dr. J. Hawgood, the Director of the Computer Unit, for the provision of the facilities I have required for the project and for his advice during the development of the system.

Finally, I am indebted to Mrs. P.A. Croft for the care and efficiency with which she has typed this thesis, the System Report and the Programme Documentation.

D.M.R. BELL
August 1973

A COMPUTER BASED COLLEGE RECORD SYSTEM PROVIDING FOR
RECORD INTERROGATION AND DATA INTERCHANGE

C O N T E N T S

Chapter 1. DATA MANAGEMENT SYSTEMS

- 1.1 An Introduction to BCRS
- 1.2 An Introduction to Data Management Systems
 - 1.2.1 Definitions
 - 1.2.2 The Application-Orientated Data Management System
 - 1.2.3 The General Data Management System
 - 1.2.4 Users of Data Management Systems

Chapter 2. THE ESTABLISHMENT AND MAINTENANCE OF A
DATA MANAGEMENT SYSTEM

- 2.1 External Organisation
 - 2.1.1 The Management
 - 2.1.2 The Data Manager
 - 2.1.3 Other Responsibilities
- 2.2 Internal Organisation
 - 2.2.1 Information and Data
 - 2.2.2 Records
 - 2.2.3 Files
- 2.3 Maintenance

Chapter 3. INFORMATION RETRIEVAL

- 3.1 Types of Retrieval Systems
 - 3.1.1 Batch Retrieval Systems
 - 3.1.2 On-Line Retrieval Systems
- 3.2 The Cost of Efficient Retrieval
 - 3.2.1 The Users
 - 3.2.2 The Record and File Structure Used
 - 3.2.3 The Availability of the Data
 - 3.2.4 The Status of the Machine
- 3.3 Interrogation and Retrieval
 - 3.3.1 Interrogation and Retrieval in BCRS

Chapter 4. DATA INTERCHANGE

- 4.1 Data Interchange Systems
- 4.2 The BCRS-D.E.S. Data Interchange

Chapter 5. THE SECURITY OF DATA MANAGEMENT SYSTEMS

- 5.1 Integrity
 - 5.1.1 Error Types
 - 5.1.2 File Recovery Techniques
- 5.2 Privacy
 - 5.2.1 Invasions of Privacy
 - 5.2.2 Counter Measures against Invasions of Privacy
- 5.3 The Retention of Data

References

Appendix 1. TECHNIQUES OF FILE ORGANISATION

Appendix 2. BCRS....BEDE COLLEGE RECORD SYSTEM
System Description and User's Guide

Appendix 3. BCRS....BEDE COLLEGE RECORD SYSTEM
Programme Documentation, Part 1

Chapter 1

DATA MANAGEMENT SYSTEMS

1.1 AN INTRODUCTION TO BCRS

BCRS, Bede College Record System, is a small application orientated Data Management System designed to record, maintain and provide access to the files in a data bank of student records.

The College of the Venerable Bede was founded as a Church of England Training College for Schoolmasters in 1839 and it was recognised as a constituent College of the University of Durham in 1947. In 1971-1972 there were 714 students at the College, the majority of whom were working for a Teachers' Certificate. In 1971 a proposal by the College for the development of a student record data bank was accepted by the University of Durham Computer Unit and work by the author on the system began in February of that year.

The University of Durham and the University of Newcastle upon Tyne have joint ownership of an IBM 360/67 computer. This computer, known as the Northumbrian Universities Multiple Access Computer (NUMAC) is run under the control of the IBM Operating System OS/360 or the University of Michigan Terminal System, MTS. Durham has access to the NUMAC computer in 'batch' mode via an IBM 1130 computer and in 'conversational' mode via IBM 2741 terminal typewriters. Access in conversational mode is only possible when the computer is being run under MTS.

The first Data Management System to be developed was completed in May 1972 and was designed to run under MTS in batch or in conversational mode. This system is no longer



in use as further developments of the project made the facilities offered by the programmes inadequate and reduced the need for allowing conversational mode. The present system was completed in April 1973 and is designed to run under MTS in batch mode. This system incorporates all the facilities available in the first version and includes more powerful techniques of interrogation and retrieval. It also includes a data interchange system with the Department of Education and Science at Darlington, providing for the transfer of data to their ICL 1904E computer.

In the development of a Data Management System to record and maintain the records of students at a College of Education, a 'bank' of information is being accumulated for current and future research. This information will not only assist the College to evaluate and assess the courses and practices of today, but it will provide a useful means of monitoring the experimental schemes which may be introduced as a result of such evaluations. It will also provide a useful source of information for the individual research student investigating such fields as student populations or student achievements.

The Data Management System BCRS consists of a suite of four PL/1 (Programming Language 1) programmes known as R, F, I and D. Programme R establishes and maintains the student records, programmes F and I provide frequency counts on various aspects of the information recorded, and programme D produces the card output for the data interchange system with the Department of Education and Science.

The programmes R, F and I provide the user with a series of OPTIONS, each performing one or more tasks in the Data Management System. The user invokes an option by means of an

OPTION PARAMETER CARD. This card contains specifications of the data file required, the task to be performed, and the value of any parameters required for that task. During the execution of one of these programmes any number of options may be selected, allowing the user to process several different data files.

The information recorded in each record can be divided into five groups as follows:

1. General and Demographic. This group consists of such items as reference number, name, sex, date of birth, marital status, religion, region and settlement of origin, position in family, previous occupation, and parent/guardian occupation.
2. Previous Education. This group includes the type of schools attended, Colleges and Universities attended, and all external academic examinations taken since the age of 11.
3. Course Details. This group includes the details of the course taken by the student and the details of any changes of course made by the student during his College career.
4. Annual Progress. This group records the assessments of the student's progress throughout his career at College, the final result, and the student's subsequent career.
5. Psychometric Information. The information recorded in this group consists of the scores achieved by the student in the following tests:

- 5.1 A Study of Values (Allport, Vernon and Linsey)
- 5.2 The Dogmatism Scale (Rokeach)
- 5.3 A.H.4 Intelligence (Heim)
- 5.4 Personality Factors

The Standard Ten (STEN) scores are calculated from the Personality Factors and are also recorded.

The volume of information recorded is not large (approximately 2416 characters per record) and every year a file of some 2000 to 2200 records is added to the data bank. To date, the system contains four files, corresponding to the intake to the College in the years 1969, 1970, 1971 and 1972.

A detailed description of the system is provided in the System Report and User's Manual, Appendix 2; and an introduction to the technical design of the programmes is provided in Part 1 of the Programme Documentation, Appendix 3.

1.2 AN INTRODUCTION TO DATA MANAGEMENT SYSTEMS

1.2.1 Definitions

In introducing BCRS we used without formal definition the terms Data Management System, Data, and Data Bank. The rapid development in recent years of data base technology has left little time for the standardisation of terminology. Several bodies and individuals have begun to adopt common definitions which are slowly becoming more widely accepted.

In this document I propose to adopt as closely as possible the definitions stated in the IFIP GUIDE TO CONCEPTS AND TERMS IN DATA PROCESSING^[43].

1. **Data Management System:** A system for establishing and maintaining the files of a data bank and of providing access to those files for the purposes of information manipulation, interrogation and retrieval.

This is not a standard definition and such systems are known by many names*. This definition is an attempt to include both the application-orientated system and the general application-free system.
2. **Data Bank:** A comprehensive collection of files manipulated by one data management system^[43].
3. **Data Base:** The set of files required for a given data processing application, commonly selected from one or more data banks^[43].
4. **File:** A collection of data, complete in some sense for a particular purpose^[43].
5. **Data:** A representation of facts or ideas in a formalised manner capable of being communicated or manipulated by some process^[43].
6. **Data Item:** A data item is the smallest unit of named data^[42].
7. **Data Structure:** A system of interrelationships established between items of data, or between their addresses or identifiers, to facilitate processing^[43].
8. **Key:** a string of characters used to identify an item of data (or a record)^[43].

*A list of some of the names for such systems is provided in an article by Byrnes and Steig^[5]. It includes: Data Management Systems, Generalised Data Base Management Systems, Generalised Data Management Systems, Information Systems, Management Information Systems, General Information Systems, Information Management Systems, and others.

1.2.2 The Application-Orientated Data Management System

The vast majority of Data Management Systems in use today are application orientated, i.e. they have been developed for a particular application and their use outside that application is limited, if at all. Recent developments have been made in providing a 'General' Data Management System, one which can function independently of the application and hence independently of the data it manipulates. Over the last few years many systems of this type have been developed, and summaries and comparisons of these systems have been made and published^[5,13,14].

The usual approach adopted in the development of an application-orientated Data Management System is to define a relatively simple data structure and to provide a suite of programmes designed to perform the tasks of Data Management using that structure. This method is often sufficient but its great disadvantage lies with its inflexibility.

In manual systems the ability to create and use alternative routines to handle exceptional cases when they arise is easy. In computing systems it is not easy and usually costly. The rigorous data structure often defined at an early stage in the development of the system now becomes a burden as more complex information has to be distorted to fit the structure. Subsequent reprogramming and indeed the subsequent redefinition of the data structure usually fails to rectify this problem as the inflexibility within both programmes and data is now inherent within the system.

This problem exists in BCRS in the recording of a student's previous education where the fixed record structure allows up to a maximum of 30 qualifications to be recorded per record. As

yet the unlikely case has not occurred but sooner or later a student will enter the system with more than 30 qualifications. BCRS provides a warning message requesting the user to ensure that the most important qualifications are recorded within the first 30, but thereafter information is lost and the system, unable to handle the unlikely event, becomes inflexible.

A further problem often encountered with application-orientated systems is that the programmes to manipulate the data depend on that very data and cannot treat it merely as a commodity for manipulation. In BCRS for example, a change in the physical representation of the data caused by the adoption of a different coding system between the years 1971 and 1972 has resulted in a series of exception routines throughout the whole system. Given that the alteration in the coding system was inevitable, these exception routines would not have been required had the system been able to function independently of the actual data itself.

An advantage for such Data Management Systems is that they can usually be implemented both quickly and cheaply. Running costs however may be high since the duplication of data may be required for use in other systems.

1.2.3 The General Data Management System

The development of the General Data Management System has arisen for several reasons. Over the last few years there has been a drift away from the traditional concept of programme and data structures which, although suitable for most numerical applications where the two can be considered dependent but separate, are not suitable for the problems of today. This is

particularly true in the data base field where real life discrepancies exist which cannot be corrected or forgotten and have to be accepted. To enable this to be successfully carried out, a new philosophy towards programming is evolving, removing the conventional distinctions between programmes and data structures.

As a result of the abandoning of conventional distinctions, General systems provide greater flexibility which we would be unable to achieve otherwise. Consider for example the General system which allows the use of many different file structures. In this case a file structure may be adopted which is most suitable to the application or indeed to the particular task within the application. Again a system which permits a variety of file search techniques enables the user to adopt say sequential access in one task and direct access in another. Data also becomes more flexible, reducing if not removing the need for exception routines like those previously discussed, and by techniques such as normalisation, troublesome repeating groups can be eliminated. Normalisation and repeating groups are discussed in a later chapter.

One of the important considerations in the development of any Data Management System must surely be the cost of the implementation and the maintenance of that system. The application-orientated system, relatively cheap to establish, may be expensive to run and maintain. The General system, although expensive to develop, can be used, perhaps with a minimum of alteration, for many applications. Furthermore it would allow the same data bank to be used by many different applications, thus reducing the number of copies which would have otherwise

been required.

Expenses such as those required to reprogramme the application-orientated system when the unlikely event occurs or when there is a physical change in the representation of the data would now be greatly reduced. This in turn would free experienced programmers from the day to day maintenance of the data bank, to work on other projects.

The costs of security must also be considered. It becomes increasingly more expensive to provide adequate security measures for many different data banks in separate locations. The centralisation provided by the General system may reduce this cost, although in many cases the actual problems of security will become more acute.

Another reason for the development of the General Data Management System is the need for faster and more economical retrieval. Management facing critical decisions about sales or production for instance, may require a rapid response to several complex questions. The answers to these questions which under manual systems may require days to calculate can now be provided very quickly, especially if all the relevant data is available at the same location.

Having discussed some of the reasons for the development of the General Data Management System, let us now consider what facilities such systems should offer.

The system must provide a high degree of flexibility. It must allow different data structures to be imposed on the data it records so that the best data structure for the particular application or task can be selected. In doing

this the application programmer can be freed from knowing how the data is structured and the medium on which it is recorded. The system must also allow several search techniques. This again allows the best technique most appropriate to the application to be used.

As an extension of the flexibility of the system in allowing programmes to be independent of the data they manipulate, the system should also allow access to be made in several different programming languages. In this way the application programmer can take advantage of the facilities offered by different languages and yet still maintain the same control over the data to be processed.

The system must also allow more than one programme to access the data base or part of the data base at the same time, and in so doing it must provide a high degree of integrity and security. The problems of integrity and security are discussed in chapter 5.

To provide these facilities is however a difficult task, and although recommendations have been put forward, notably those of the DATA BASE TASK GROUP REPORT TO THE CODASYL PROGRAMMING LANGUAGE COMMITTEE^[42] and others^[7,30], there still remains a considerable amount of work to be done before the really General Data Management System becomes a commercial proposition.

1.2.4 Users of Data Management Systems

In the previous two sections we considered many of the aspects involved in the development of the application-orientated and the General Data Management System. Some of these aspects we shall be discussing further in subsequent chapters. In this

section let us consider the users of such systems.

With the development of General Data Management Systems and the increasing popularity and use of application-orientated software packages (SSSP: Social Science Statistical Package, for instance) it is no longer considered that the programmer should be the only person to be able to communicate with the computer. Today, in the data base field, there are generally considered to be four levels of users, each requiring to interact with the system in a different way.

1. The Data Manager and System Programmer

The Data Manager should be one of the most experienced members of the development and support team of the system. He should be experienced both in conventional programming languages and as a systems analyst. He would make the initial decisions about the structure and the type of system to implement and he would be responsible for the organisation and maintenance of all or part of the data base and for any decisions concerning the revision of the system, i.e. the redefining of the file or record structures. Responsible to the Data Manager, and probably interacting with the data base at system level, a team of system programmers would implement various aspects of the system, such as security and access control.

2. The Application Programmer

The application programmer would be responsible for providing procedural programmes, probably in host languages such as Cobol or PL/1 or extensions of these languages, to operate on the data base for specified applications.

3. The Self-contained User

This user does not have to know a conventional programming

language. He requires to interact with the system in the language provided with the data base. This language should be user orientated, enabling such tasks as updates, interrogation and retrieval to be performed.

4. The Parametric User

The parametric user or non-programmer user is the lowest level of user and does not have to know either a conventional programming language or the self-contained data base language. He communicates with the system by invoking procedures which have been predefined by a higher level of user. These procedures he knows how to invoke, but not how to define, although he may have the responsibility of providing specified parameters when required.

Not surprisingly, the lower levels of users introduce another requirement into the development of Data Management Systems. This requirement - that the man/machine interface should be as simple as possible - is of great importance. Data Management Systems particularly the General systems should be designed for use by experienced and inexperienced users alike. Some systems, in particular the systems providing on-line interrogation and retrieval, achieve this by providing different modes of use. A learner mode is provided for the beginners and an experienced mode for those already familiar with the system. Such techniques however also increase the development and running costs. Other systems, especially those that are application orientated are designed to consider all users as parametric users and provide a step by step documentation of what can and cannot be done. This approach is usually adequate provided the user wishes to remain within the bounds of the

tasks provided. If however he requires a facility which is not predefined, a higher level of user has to be consulted.

Chapter 2

THE ESTABLISHMENT AND MAINTENANCE OF A DATA MANAGEMENT SYSTEM

In chapter 1 we discussed the application-orientated and the General Data Management System and we considered what facilities such systems would have to offer to fulfil their functions. In this chapter we shall consider the organisation required to establish and maintain a Data Management System.

The decision to implement a Data Management System gives rise to many complex and involved tasks. Not only are there problems concerning the recording of information - what information to record, on what medium and in what format - but there are also human problems to be considered. One such problem - the need for a simple man/machine interface - we have already mentioned.

Many of these problems must be considered as problems of organisation and in the development and implementation of a Data Management System organisation falls into two areas. External organisation, the organisation required to allow the system to be established and developed; and internal organisation, the organisation of the system itself.

2.1 EXTERNAL ORGANISATION

The external organisation behind the implementation of a Data Management System is very important and the major responsibilities fall on the Management, i.e. those who decide to implement the system, and the Data Manager, the person responsible for its implementation.

2.1.1 The Management

The initial decision to implement a Data Management System and the final responsibility for it must lie with the Management, be that Management a representative body of a company or an individual.

The cost of the system must be carefully considered along with the type of system, on or off-line, and also the cost of providing new equipment where necessary. In these areas the Management should be in close contact with the Data Manager who should advise on what equipment to purchase and how best to utilise existing equipment. He must also ensure that the Management seriously considers such problems as security, as many of the decisions made at this level will be of direct consequence to him when he develops the system.

2.1.2 The Data Manager

Once the decision has been made to implement a Data Management System it becomes the Data Manager's responsibility to do so. Initially he will have been responsible for providing advice to the Management about what systems are available and whether any of these systems would meet the requirements of the application. Eventually he will be responsible for decisions about the type of system to develop and implement. He will have to consider which record and file structures to use, and whether the system should adopt a host language or be developed using the self-contained language of an existing system. He will also have the responsibility for decisions about the maintenance, revision and security of the system.

To make such decisions the Data Manager must have a clear idea of the system as it exists at present, of the information to be recorded, and of the needs of those using that information. It is his responsibility to ensure that any system that is implemented meets these requirements.

2.1.3 Other Responsibilities

One of the important aspects of the implementation of a Data Management System is the effects that the system will have on present staff. This problem, known to sociologists as socio-technical relations, is important as many members of staff, startled by the apparent complexity of 'the computer' and ignorant of its basic simplicity, may consider it as a threat to their jobs. This however is seldom if ever the case, but often the introduction of a Data Management System alters the emphasis of the job specifications of these people. One of the best ways to reduce tensions in this field is to keep them informed about the system and if possible directly involved in preparing for it and for its maintenance. The responsibility for this must fall on all who are involved in the development and implementation.

Good examples of well implemented Data Management Systems are still few, and although a vast amount has been published about the place of these systems in society and in industry very little assessment has been made of the cause and effects of their use. Banbury^[1] when discussing Management Information Systems states that "the use of computers ... clearly places the onus upon the systems designer and the manager to recognise some of the possible consequences of the

massive integrating system" and he concludes that the implementation of such systems may lead organisations towards more centralised decision-making which he warns "is not necessarily the right answer every time".

2.2 INTERNAL ORGANISATION

The internal organisation of a Data Management System concerns the actual organisation of the system itself, what file structures to have, and how and in what format to record the data. The simplest method is to have a suite of programmes each with their own data files and, although this method may in some cases be satisfactory, it often gives rise to data redundancies where the same information is recorded in several files. To provide good internal organisation the Data Manager must consider several factors.

1. The Application

Where Data Management Systems are developed for a particular application the nature of that application often helps to dictate the internal organisation of the system. If, for example, the users of a system require fast on-line retrieval, then a file structure allowing direct access would be an advantage. File maintenance must also be considered. For large updates where the volume of information to be added to the data base is great, sequential access might be used, while for small updates, say the alteration of one or two fields in a particular record, direct access to locate that record would be more efficient.

2. The Facilities Available

The internal organisation of a Data Management System may also be influenced by the facilities available at the installation where the system is to be implemented. The organisation of a system designed to be used on a large computer with disc and drum backing store will be very different from that designed for a smaller computer using magnetic tapes. The availability of input and output devices must also be considered and the facilities offered by the software that the installation supports. The compilers available, for example, will affect the choice of a host language where one is to be used.

3. The Money and Time Available

Both these factors may influence the design and organisation of the system. If money is short a simple system may be implemented using as far as possible existing equipment, whereas if both money and time are available a complex system may be developed and new equipment purchased.

The application, the facilities, money and time available are all factors which influence the internal organisation of a Data Management System. They also provide some of the reasons for the need for record and file structuring.

In most systems information is grouped together into logical records. Due to the limitations of hardware and software and the need for such groupings of data in problem analysis, these records are then grouped into files. The organisation of these files is the foundation on which the Data Management System is built. It dictates the search techniques to be used during retrieval, the physical size of the data base and the amount of information redundancy. There

are several file organisation techniques which we shall discuss later, but the choice of organisation used not only depends on the application but also on the complexity of the information to be manipulated.

2.2.1 Information and Data

The majority of Data Management Systems record data. It is usually recorded as explicitly coded data items or data values which, only when provided with attributes by humans, does it become meaningful information.

Consider for example the set of figures:

251260

These figures could be interpreted in many ways, if indeed they need be interpreted at all, and in their present form they represent meaningless data. If we were subsequently informed that the set of figures above represented a date of birth, then by providing the interpretation of the data:

DATE OF BIRTH IS 25/12/60

we have established meaningful information.

The main disadvantage of recording information as explicitly coded data items is its inflexibility. An alteration in the content of the information to be recorded, such as the addition of several new fields, would require structural alterations in the programmes concerned. To increase the flexibility of the information recorded, some languages allow free format. CODIL (Context Dependent Information Language^{[28,29,3} for instance, records all information as:

<data item>:=<data name><logical relation><data value>

By providing a wide range of logical relations and allowing the user to define his own data names, some of the flexibility of natural languages can be retained.

In BCRS both techniques are used and although most of the information recorded consists of explicitly coded data items, in the recording of the Annual Progress of a student a free format has been used. The continually changing structure of courses offered by the College gave rise to the need to adopt this technique, and data items are recorded as:

`<data item>:=<field label><=><field value>`

where the field labels correspond to a set of predefined fields which the user wishes to record. All the field values are then recorded in the same vector (the Annual Progress Vector) and the field labels are used to point to two field keys, the first of which records the starting point of the field value within the vector, and the second records the length (number of characters) of that value. The techniques adopted to allow new information to be added to the vector and to allow the respecification or removal of existing information is discussed in Part 1 of the Programme Documentation, page 16, Appendix 3.

Data Relations

The relations which exist between data items may be internal, i.e. they may exist between the data values contained within a single record, or they may be external and exist between the records of a particular file or a particular set of files.

The field labels previously discussed form external relationships between their corresponding field values in all records where the field label has been defined to represent

the same entity. If the user subsequently redefines the field to which the field label refers, the relationship is broken.

In BCRS internal relations exist between several data items. For example, in each record the number of qualifications recorded (QUALNO) provides an internal relationship with the array (QUAL) where the qualifications are recorded. We can say that there are QUALNO qualifications in the array QUAL. Such a relation forms a repeating group which may lead to a complex data structure difficult to handle. The technique of normalisation^[7] is designed to reduce such complex data structures to simpler structures, eliminating where possible the repeating groups.

Consider the structures given in Figure 1.

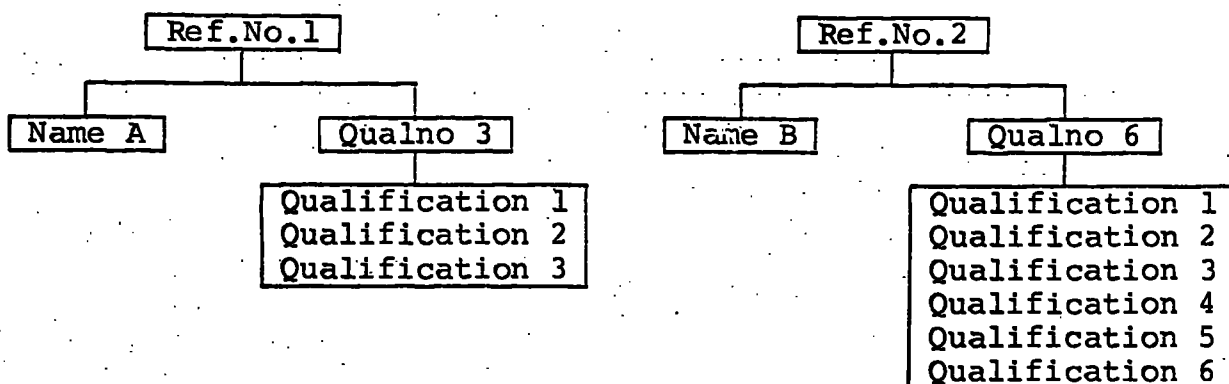

FIGURE 1

The number of qualifications recorded by each student is different and forms a repeating group within each record. These repeating groups can be eliminated by reducing the structures to the simpler forms shown in Figure 2 and Figure 3.

| Refnos | Names |
|--------|-------|
| 1 | A |
| 2 | B |

FIGURE 2

| Refnos | Qualifications |
|--------|-----------------|
| 1 | Qualification 1 |
| 1 | Qualification 2 |
| 1 | Qualification 3 |
| 2 | Qualification 1 |
| 2 | Qualification 2 |
| 2 | Qualification 3 |
| 2 | Qualification 4 |
| 2 | Qualification 5 |
| 2 | Qualification 6 |

FIGURE 3

We now have two simple relations; Figure 2 contains a relation between RefNos and Names, and Figure 3 a relation between RefNos and Qualifications. It should be noted however that in reducing the original structure to a set of simple relations we have increased the data redundancy, and if RefNo was a keyed item, then although it still remains unique in the relations in Figure 2 it does not in Figure 3, where it provides reference to a set of data items. Nevertheless we have shown that the data structures can be reduced to a set of simpler relations which are both easier to record and easier to manipulate.

Another important aspect in the recording of information as data concerns the types of the data representations acceptable to the Data Management System, since it must be remembered that data items with different attributes can be recorded in different ways. Where information is recorded as explicitly coded data items, specified attributes can be declared, but when a free format technique is used, data conversions may be required to ensure that the data item has the correct attributes for the operation being performed.

2.2.2 Records

The grouping of data items into records provides a convenient way of recording and manipulating related or unrelated information. In most cases a record describes an entity. A BCRS record for instance contains all the information about a student. This information is related (i.e. it concerns the student) and it can be further divided into logical divisions sometimes known as elements. A record element may contain one or more fields as defined by the user and they may be fixed or varying in size.

With varying length elements it is sometimes convenient to have a 'table of contents' within the record providing the relative starting addresses for all the elements included. This would allow element retrieval as well as record retrieval, thus providing greater flexibility.

In some cases the user may wish to provide keys with each record to enable direct access techniques to be used during retrieval. A key may be a single data item or a group of several data items contained within each record, it it may be an external key provided when the records were established in the file.

2.2.3 Files

There are three main file organisation techniques in use today: Sequential Organisation, Random Organisation and List Organisation. In this section we shall discuss each type briefly; a detailed discussion giving illustrations of each type can be found in Appendix 1.

Sequential Organisation

In a sequential file, records are recorded in a specified sequence. This sequence may depend on the value of a common attribute within the records or it may correspond to the order in which the records arrived in the file. This type of organisation allows rapid access to successive records but the retrieval of out of sequence records may be slow, depending on the number of records in the file and the position of the required record.

Random Organisation

In random organisation a relationship is established between

the key of a record and the address or location of that record on a direct-access storage device. This relationship provides the means of access to the record by direct address, dictionary lookup or address calculation techniques. Random file organisation provides a varying degree of efficiency. When direct addressing can be used it is very efficient. Dictionary lookup however requires a scan of the dictionary before the address can be found. A sequential scan is often used for this, or a binary search technique; and address calculation may require transformation algorithms if collisions occur during the calculation of an address from a record key.

List Organisation

In list organisation the logical organisation of the records within a file is maintained by the use of pointers. These pointers may be addresses, for example the pointer in one record may be the address of the next record in the sequence and hence the records can be recorded in any physical order. There are three main types of list organisation: simple list, inverted list and ring, each of which provides a varying degree of efficiency.

The selection of a suitable file structure will depend on the physical constraints of the computer system (i.e. the hardware available) and on the software constraints, in particular those of the Operating System.

In BCRS the files are organised sequentially in ascending order of Reference Number. This technique was chosen for several reasons:

1. **Simplicity:** Sequential organisation is perhaps the simplest organisation to implement as there are no problems of key

and index maintenance. It also provides for extremely easy usage and can be more readily understood by non-computing users wishing to use the system.

2. Maintenance: The majority of maintenance carried out in BCRS concerns the updating of nearly all the records in a specified file. The addition of the Annual Progress for a given year for instance will most probably involve the addition of information to every record. Sequential organisation giving rapid access to successive records is ideal for this type of maintenance provided the updates are collated in the same sequence as the records. Some small volume updates are also carried out but typically not many per year.
3. Retrieval: Like maintenance, the majority of retrieval carried out concerns every record. Sequential access however may not be the most efficient method when retrieval is based on some selection criteria. One such typical criterion might be 'select the students who have 3 A'levels and O'level passes in English Language and Mathematics'. In BCRS sequential access is still used, reducing the need for maintaining a complex indexing structure which would otherwise be required to allow as wide a range of record selection as possible.
4. Software constraints: Ideally, index sequential would have provided a better organisation technique since it would have allowed sequential or indexed (direct) access to be used, depending on the requirements of the task. To implement it however each record would have to be divided into several smaller records since the present version of MTS does not

support index sequential organisation with records greater than 255 bytes. This in turn would reduce the simplicity of the system, making implementation more difficult and usage more complex.

2.3 MAINTENANCE

The maintenance of a data base is usually considered as the updating of the data files with additional information or more up-to-date information. The organisation involved in this maintenance again falls into two areas: external organisation and internal organisation.

In the external organisation of file maintenance there are several important points to consider. In large systems maintenance is often carried out by several people from different locations and at different times. The difficulty then arises of knowing what has been done and what has not been done, and in these circumstances careful monitoring of the system is essential.

The accuracy of the information recorded is also important, especially in personnel data files. One good method of ensuring that the information recorded is kept up-to-date is by forwarding a copy of the information to the individuals concerned asking them to mark any alterations which may be required. When the copy is returned the records can be altered appropriately. This technique has the further advantages of informing the individuals of the information recorded about them.

The internal organisation required during maintenance will depend on the type of file structure used. With list organisation for example the addition of several new records in a file

may require a complete reordering of the pointers, and the time spent on the maintenance of inverted indexes may be considerable. With sequential organisation this problem does not arise unless a reordering of the records is required.

The Maintenance of BCRS

In BCRS the maintenance of the data files is carried out by three people, two College representatives and a Computer Unit Data Manager. The College representatives are responsible for providing the information to be recorded and the Data Manager is responsible for ensuring that this information is placed in the data bank. The Data Manager records all maintenance carried out and hence the status of the system is always known. The lines of communication between the users and the data bank are shown in Figure 4.

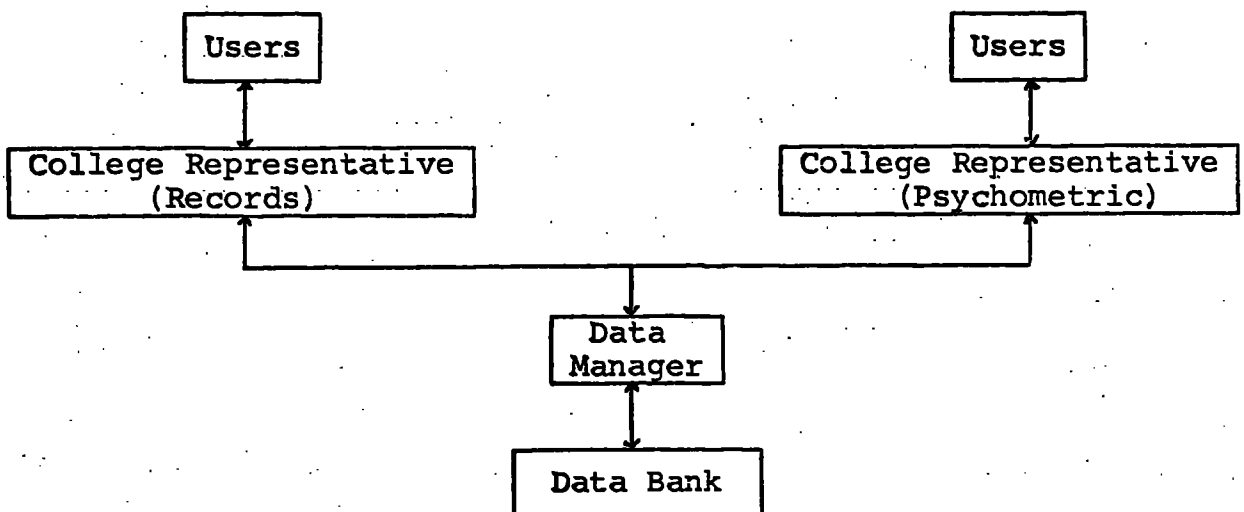

FIGURE 4: BCRS lines of communication

On admission to the College a record is established for each student. Maintenance takes place once per year while that student is at the College. If a student withdraws prior to completing his course, then a further update is carried out to record the withdrawal. As sequential file organisation is used,

no index maintenance is required and the addition of further records takes place so infrequently that the records are not usually reordered, although the facility to do so exists within the computing system software if required.

Chapter 3

INFORMATION RETRIEVAL

Today the techniques of information retrieval are changing rapidly. These changes, which are arising perhaps from the user's need to utilise information more fully or from new developments in hardware and software, provide the stimulus for the development of flexible retrieval packages and algorithms which are both economical and easy to use. The provision of these facilities forms an integral part of a Data Management System, often providing the very reason for the implementation of the System itself. In this chapter we shall consider some of the approaches to information retrieval and we shall discuss the approach adopted in BCRS.

One of the many problems with the provision of an efficient retrieval service arises from the wide range of uses of such a facility. Barlow^[2] discusses four possible divisions of an information service: current awareness, info-retrieval, documents, and products engineering data. In one case these divisions deal with the searching of a data base to provide answers to specified problems, while in another case, the retrieval of documentation on research and development is required. To provide all these facilities, an information service would require complex and flexible retrieval routines.

Another consideration involves the users themselves, the majority of whom are primarily not interested in the retrieval service itself but only in what it retrieves. As this gives rise to a wide range of both frequent and infrequent users, a simple man/machine interface must be provided.

3.1 TYPES OF RETRIEVAL SYSTEMS

There are two types of retrieval systems: batch systems and on-line systems.

3.1.1 Batch Retrieval Systems

The main use of a batch retrieval system arises when the retrieval required produces large quantities of output, or when retrieval time is not critical. The system has its disadvantages in the slow turn-round time and the inflexibility of not being able to vary the search criteria as retrieval takes place.

3.1.2 On-Line Retrieval Systems

The on-line retrieval system overcomes both the disadvantages experienced with the batch system. With large time sharing computers a direct response to a request or query is provided and the user can if required modify the query before making a further request. In this environment retrieval time is critical and output should be kept to a minimum, to reduce printing time. Such systems can only be effectively supported where direct access storage is available.

One important factor which must be considered in both systems is the ability and experience of the users, as misuse due to inexperience can be costly. On-line systems may adopt modes of use, learner mode and experienced mode, but this adds overhead costs to the development and running of the system. The first version of BCRS, when used on-line, provided only one mode of use, an abbreviated learner mode to supplement documentation. Some users familiar with the system found this method frustrating.

3.2 THE COST OF EFFICIENT RETRIEVAL

With the ever increasing cost of computing facilities and the need for quicker and more accurate decision making by management, the cost of an efficient retrieval service is important. This cost usually varies considerably depending on the application and the complexity of the retrieval required, but it can be greatly influenced by several factors.

3.2.1 The Users

Perhaps the two most important considerations involving the users of information retrieval services are their experience and their requirements. The experience of the user we have already mentioned, but the requirements of users vary greatly and in some cases are not fully specified before the system is implemented.

In cases where the user can specify what items are to be retrieved a fixed retrieval format can be used. Where the user does not know what items will be required a free retrieval format is required, allowing the user to specify the items to be retrieved and the format in which these items are to be printed. This type of facility, although very much more flexible than the former, places more responsibility on the user.

A further consideration involves the facilities required. Visual display units would be extremely useful for users wishing to browse through records or documents. Other users may wish to record retrieved items in files or on cards for subsequent processing, giving rise to the need for flexible input and output routines utilising several devices.

3.2.2 The Record and File Structure Used

As the cost of retrieval is a function of the efficiency of retrieval the record and file structures adopted by the Data Management System become of great importance. In large time sharing installations, direct access techniques provide maximum efficiency especially if all index, relation or dictionary tables can be held in core. With inverted file structures, index tables can be searched quickly and retrieval to the main records need only be made if information not recorded in the index tables is required.

In smaller installations, perhaps not supporting direct access devices, sequential method would have to be used. To increase efficiency, the collating of keys to correspond to the order in the files can reduce search time, although seldom more than one pass through the file should be required.

The complexity of the search criteria is also important and very involved requests which cannot be answered from the index or relation tables would require the retrieval of every record. In these circumstances sequential access methods, giving fast access to successive records could be used.

3.2.3 The Availability of the Data

Another important point which can influence the efficiency of retrieval concerns the availability of the information. Files which are not frequently accessed may reside on less accessible media than those that are in frequent demand. Likewise careful monitoring of the most frequently used record fields may be useful in deciding which items should be record keys, but subsequent requests for non-keyed fields may then take longer to answer.

3.2.4 The Status of the Machine

The current status of the machine is more important in on-line systems than in batch systems. At any given time the efficiency of an on-line system will depend on the number of users currently active on that system. As the number increases so the response time decreases. Similarly response time may also decrease if large index or relation tables are used, since this may result in extra paging by the system.

3.3 INTERROGATION AND RETRIEVAL

Record interrogation may be considered as a particular aspect of retrieval where a specified question or set of questions are posed. Having provided an answer to these questions, retrieval of items unrelated to the search criteria may be obtained from the set of records identified. For example in BCRS the question:

'how many married students are under 21 years of age?' would be considered as record interrogation, while on the other hand the question:

'provide demographic information about the set of students who are married and under 21 years of age' would be considered firstly as interrogation to identify the set of students and secondly, or concurrently, as retrieval to provide the demographic information required.

This brings us to the major problem of defining and providing a suitable language through which a request may be made. The usual approach adopted is to provide a controlled language where the user phrases his request to conform to a specified syntax.

A natural language approach can also be used and although this provides far greater flexibility it also requires a much more complex request evaluation phase.

Once a request has been defined, numerous record search techniques can be used ranging from direct comparisons of required items and recorded items to complex hashing procedures and word association techniques frequently used in library retrieval projects. The eventual technique used will depend on the file structure and size of the database, the amount of core available and the complexity of the request itself.

3.3.1 Interrogation and Retrieval in BCRS

In BCRS a fixed retrieval format is used depending on the value of a specified parameter. A list of the identifiers of the students included in a particular set will be provided and this list may be accompanied by specified information about that set. This information may be a set of frequency tables based on the demographic information, or it may be based on the psychometric scores including frequency tables, means, totals and standard deviations.

Requests are specified by the user in a coded controlled language. The syntax of this language is as follows:

<request>:=<simple request><logical operator><request> | <simple request><termination>

<logical operator>:= & | ,

<simple request>:=<space><item number><relational operator>
<item value><space>

<relational operator>:= = | ≠ | > | > | < | <

<item number>:=the specified number corresponding to the field
required

<item value>:=any acceptable value for the field specified by
the item number

Consider as an example the following request:

'select the subset of students who are married and under 21
years of age'.

This request we reduce to two simple requests as follows:

1. select the students who are married, and
2. select the students who are under 21 years of age.

- or
1. marital status=married, and
 2. age<21

These simple requests can now be coded. Let us consider that
the item number corresponding to age is 1 and to marital status
is 3. Further let us consider that the item value (data value)
of a married student is recorded as code 2. The simple requests
then become:

1. 3=2, and
2. 1<21

which can be combined to give the fully coded request as:

REQUEST=' 3=2 & 1<21 '

A further example might be:

'select the subset of female students who are under 21 or over
25 years of age'.

In this example the three simple requests are:

1. select the female students, and
2. select the students who are under 21, or
3. select the students who are over 25.

If the item number corresponding to sex is 2 and the item value of a female student recorded as F, these simple requests can be coded as:

1. 2=F, and
2. 1<21, or
3. 1>25

which when combined give the full request as:

REQUEST=' 2=F & 1<21 | 1>25 '

Using this method, a wide range of requests can be coded but in some cases not enough information is being conveyed. Take for example the following request involving qualifications:

'how many students have more than 3 A'levels and O'level passes in English Language and Mathematics?'

With this request we must distinguish between A'levels and O'levels, between passes and fails and between subject codes. To do this, additional information has to be specified with each simple request. Each qualification is recorded as 10 characters in a format represented diagrammatically as:

| Year | | Type | | | Code | | Grade | P. or F |
|------|--|------|--|--|------|--|-------|---------|
| | | | | | | | | |

where year is the year in which the examination was taken;
 type is the type of qualification, O'level, A'level or HND for example;
 code is the subject code of the qualification;
 grade is the grade awarded; and
 P or F the result, pass or fail.

Then by using an '*' to denote that a field may contain

This amendment is to clarify the discussion about the order of evaluation of REQUEST which appears on pages 37, 38, Appendix 2 page 34, and Appendix 3 page 38.

REQUEST EVALUATION

In the algorithm to evaluate a REQUEST the order of precedence of logical operators, from LEFT to RIGHT, is maintained provided the REQUEST is considered in the conjunctive form with '|' taking precedence over '&'.

Thus for example the REQUEST $A \& B \mid C \& D$ can be considered in the conjunctive form as $X \& Y \& Z$, where $X \equiv A$, $Y \equiv (B \mid C)$ and $Z \equiv D$; and would therefore be evaluated as $A \& (B \mid C) \& D$.

any value, an A'level pass can be expressed as:

| Year | | Type | | | Code | | | Grade | P or F |
|------|---|------|---|---|------|---|---|-------|--------|
| * | * | * | * | A | * | * | * | * | P |

Similarly, as the subject code for English Language is 061, an O'level pass in English Language can be expressed as:

| Year | | Type | | | Code | | | Grade | P or F |
|------|---|------|---|---|------|---|---|-------|--------|
| * | * | * | * | O | 0 | 6 | 1 | * | P |

and an O'level pass in Mathematics (subject code 011) can be expressed as:

| Year | | Type | | | Code | | | Grade | P or F |
|------|---|------|---|---|------|---|---|-------|--------|
| * | * | * | * | O | 0 | 1 | 1 | * | P |

This additional information is then included in the request in parentheses after the item value, and if the item number for qualification is 21, then the fully coded request becomes:

REQUEST=' 21>3(****A****P) & 21<1(****0061*P) & 21<1(****0011*P) '

Adopting this technique when required complex requests can be precisely coded. Further examples are provided in the System Report and User's Manual, pages 32 to 40, and a full table of all item numbers and their corresponding fields is given in page 39, see Appendix 2.

As the order of precedence of logical operators is from LEFT to RIGHT and no provision is made for the inclusion of parentheses within a request, care must be taken to ensure that the correct order of evaluation is maintained. For example, if A, B, C and D are simple requests, then a request of the form:

REQUEST=' A & B | C & D '

would be evaluated as:

REQUEST=' A & (B | C) & D '

and not as might be expected:

REQUEST=' (A & B) | (C & D) '

Under these circumstances records can be accepted or rejected without all the simple requests having to be evaluated, and the following four rules govern the evaluation order of simple requests:

1. Logical operators take precedence from LEFT to RIGHT.
2. If the answer to a simple request is false and that simple request is followed by the logical operator '&', the whole request is false. This is illustrated in Figure 1 where t and f represent true and false respectively, the possible answers to the evaluation of a simple request, and accept and reject represent the possible answers to the evaluation of the full request.

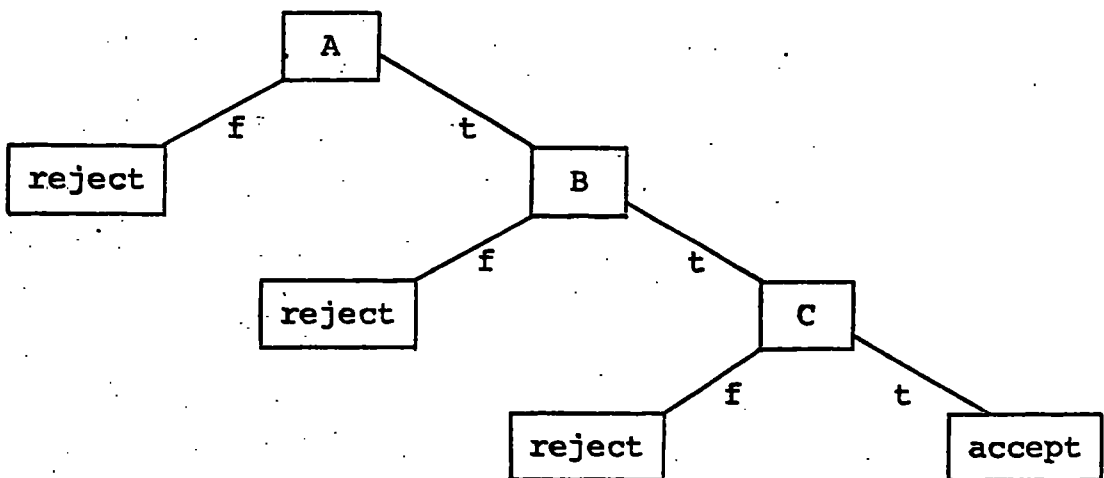

FIGURE 1: REQUEST=' A & B & C '

3. A simple request preceded by the logical operator '|' will not be tested if the preceding simple request is true. This is illustrated in Figure 2.

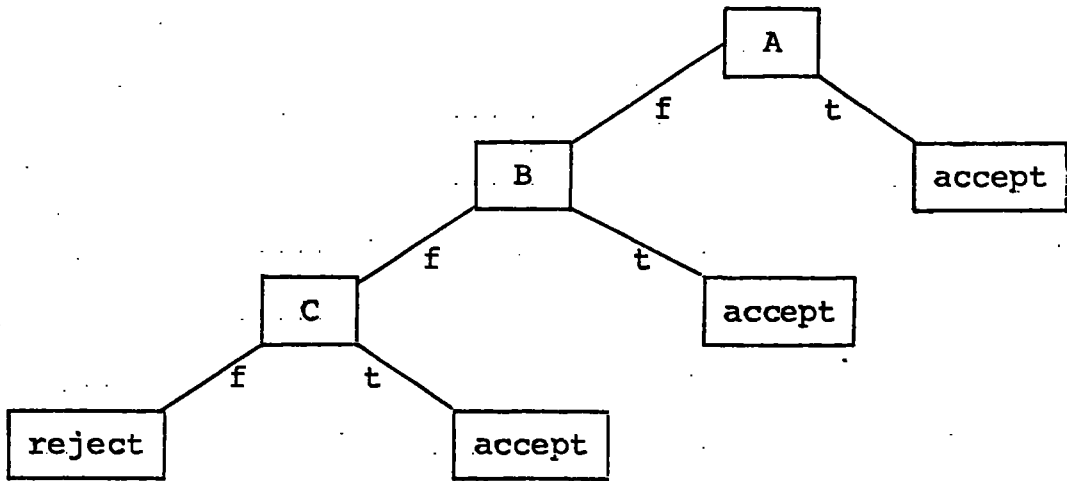

FIGURE 2: REQUEST=' A | B | C '

4. If the answer to a simple request is false and that simple request is followed by the logical operator '|' the next simple request is tested. This is illustrated in Figure 3 and Figure 4.

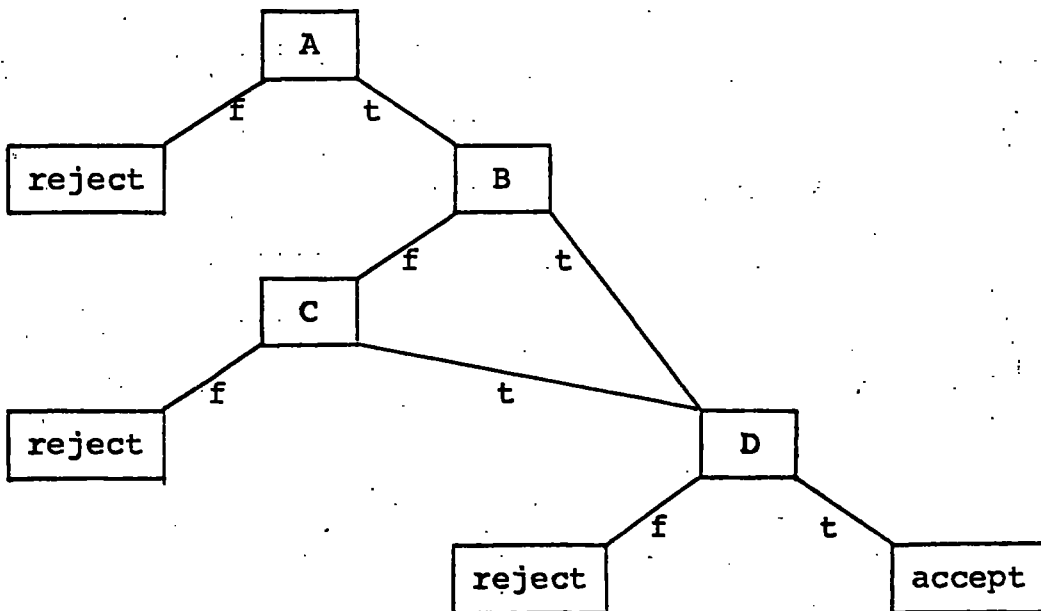

FIGURE 3: REQUEST=' A & B | C & D '

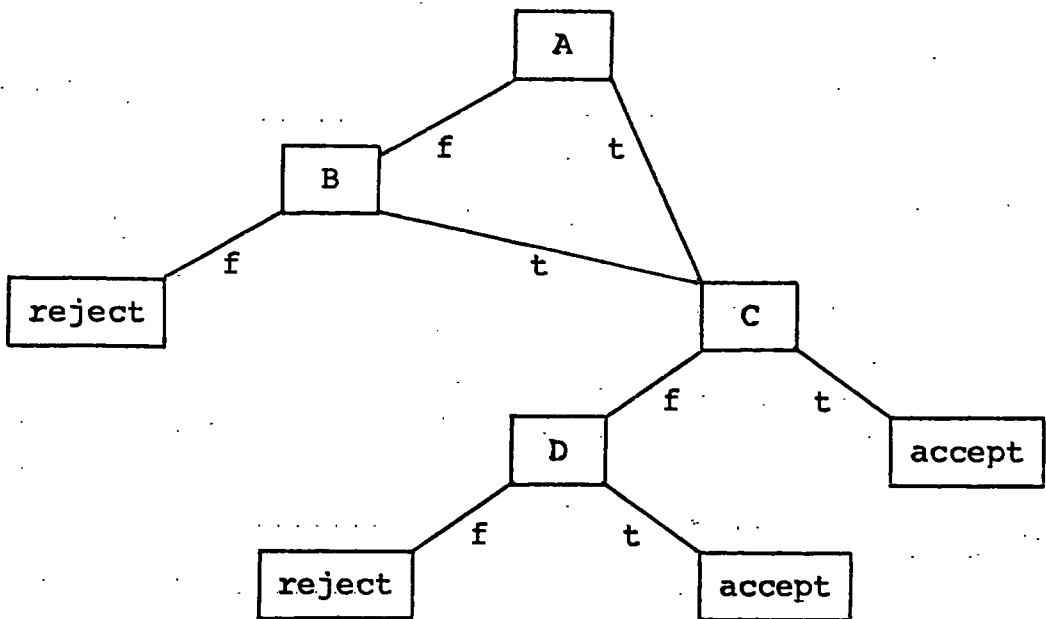

FIGURE 4: REQUEST=' A | B & C | D '

As sequential file organisation is used and no index tables are recorded it is not possible to answer any request without accessing the main records. Each record is therefore accessed in turn and the request evaluated to an accept/reject conclusion. If the record is to be accepted the record key is recorded and if further information is required this is also recorded before the next record is accessed. If the record is to be rejected the next record is accessed immediately and hence only one complete pass through the file is required.

Using this method, the search time is proportional to the number of simple requests to be evaluated and the number of records in the file, unless the request is such that an accept/reject conclusion can be returned prior to full evaluation.

Chapter 4

DATA INTERCHANGE

The context in which data interchange is to be discussed in this chapter concerns the exchange of data, either on-line or off-line, from one Data Management System to another. In its most complete form, an interchange of this type would allow the on-line transmission of data through an integrated network of many different computer systems. In a more simpler form, it may only involve the use of specified output from one Data Management System as the input to another. In both cases the amount of manual work involved in data collection and preparation would be greatly reduced; and in the former case far more information would be made more readily available for research purposes.

Considered in this context, a data interchange system presents many of the problems associated with information retrieval but there are several other important aspects which must also be considered.

4.1. DATA INTERCHANGE SYSTEMS

In the design of a data interchange system the nature of the interchange service required will most probably dictate whether an on-line or an off-line system should be implemented. In either case many non-trivial problems will have to be considered.

Standardisation

The standardisation of definitions and terminology is

particularly important and must be carried out at an early stage in the design of the interchange system. If this is not done, confusion may arise over simple concepts which may lead to difficulty when the system is being implemented or once it is in operation.

Exchange Medium

In situations where an on-line system is required, the cost of providing communication lines must be considered as well as the cost of interface units, channels and any other hardware or software which may also be required. In off-line systems it is important that a stable interchange medium is used. Computer cards provide a good medium for small volume exchanges, and magnetic tape for larger volumes of data. Magnetic tapes are however very susceptible to damage, especially if exposed to magnetic fields or roughly handled, and care must be taken in packing and transportation.

Data Accuracy

Where data interchange systems are to be used, the accuracy of the data is of great importance since fewer manual checks are made and the consequences of recording and transmitting incorrect data will be more widespread. The introduction of verification procedures during transmissions may help to detect such errors and for small volume exchanges back-up computer listings may be very useful.

Data Representation

As data is represented in many different ways in different computing systems, the compatibility of the data exchanged is

important. This may involve the use of simple software exception routines to change the representation of certain characters as required, or it may involve more complex conversion routines such as those require to handle the different tape recording techniques that are in use today.

Data Descriptors

As well as ensuring the compatibility of the data transmitted, it may also be useful to transmit a format description of the records being exchanged. Having a description of the data, recorded as say the first record of each file, can be extremely useful especially in data interchange systems where it could be used to detect any inconsistencies between the format of the data transmitted and that expected. Error warnings could be raised when such inconsistencies occur, and in on-line systems a request could be made for the re-transmission of the suspected record.

Documentation

One important aspect which must be considered involves the need for frequent reports on the development and progress of the system. Documentation must be circulated to all concerned when an alteration affecting the interchange is made to any of the systems involved. In large systems this may involve the circulation of a monthly newsletter, providing not only information on system alterations but also detailed reports on any difficulties experienced and how they might be overcome.

4.2 THE BCRS-D.E.S. DATA INTERCHANGE

In BCRS a simple data interchange system has been developed with the Department of Education and Science (D.E.S.) at Darlington. This system is primarily 'one-way' as data is prepared from the BCRS data files for use by the D.E.S., and it is designed to reduce much of the manual work involved in the preparation of the student records.

Prior to the introduction of the data interchange system the complex manual preparation of several forms was required to provide one set of records for D.E.S. and another for BCRS. The main forms used were the Bede College Personal Record Card by BCRS and the Form 3Ø T.T. by the D.E.S. Examples of these forms can be found on pages 49-58 of the System Report and User's Manual, Appendix 2. In the data interchange it was proposed that the Personal Record Card should be used by BCRS and that the data required by the D.E.S. should be prepared from the BCRS files. The resulting interchange was to be carried out off-line using computer cards as an exchange medium.

One of the first tasks to be carried out was to ensure that all the information required by the D.E.S. was available from the Personal Record Cards and was recorded by BCRS. This resulted in the revision of the Personal Record Card to its present form, and while this was being done the standardisation of many of the codes used by BCRS, to correspond to those used by the D.E.S., was also carried out.

Initially the data interchange system was designed to handle student admissions, but as the 3Ø T.T. Forms were no longer to be used, other exchange transactions had to be

developed to handle the maintenance of the student records in the D.E.S. system.

The following exchange transactions are included:

1. Admissions

In this transaction, BCRS provides admission records to the D.E.S. These records are used to establish a file of student records in the D.E.S. system.

2. Change of Course or Subject

This transaction is used to inform the D.E.S. that a student has change his course or his main subject and to provide details of that change.

3. Withdrawal and End of Course

This transaction is used to inform the D.E.S. that a student has withdrawn from the College or, having completed his course, has left the College.

4. Re-admission

This transaction is used to provide a link in the D.E.S. system between the records of students who transfer from one training establishment to another.

5. Manual Transactions

Manual transactions include all record alterations made by the D.E.S. or by BCRS which necessitate a similar transaction in the other system.

The full procedures involved in these interchange transactions are outlined in section 7 of the System Report and User's Manual, Appendix 2. These procedures can be summarised as follows:

1. Data Preparation

The relevant data is taken from the Personal Record Card and punched on computer cards in the format specified by BCRS for the task being performed. The cards are listed and checked.

2. Record Maintenance

The computer cards are used by BCRS to establish or maintain the student records in the BCRS data files. If an interchange transaction is required, a Transaction File is established by BCRS. The Transaction File contains a list of the Reference Numbers of the students required by the D.E.S. and a corresponding interchange transaction number for each.

3. Card Output

The Transaction File and the student records are used by BCRS to produce card output for the D.E.S.

4. Card Listing

The output cards are listed and any further data listing required by the D.E.S. are made.

5. Card Interchange

The output cards and the data listings are sent to the D.E.S. where the cards provide the input for the D.E.S. system.

The data interchange system is shown diagrammatically in Figure 1 on page 48.

Manual transactions such as those required for a change of student Reference Number or a change of Name, must be carried out in both systems to ensure data compatibility in subsequent

interchanges. The system initiating the transaction is responsible for informing the other that a record change has to be made.

The format of the interchange cards is specified by the D.E.S., and BCRS uses fixed retrieval format procedures to provide the data required. This data consists of the duplication of record fields as well as record statistics involving student qualifications.

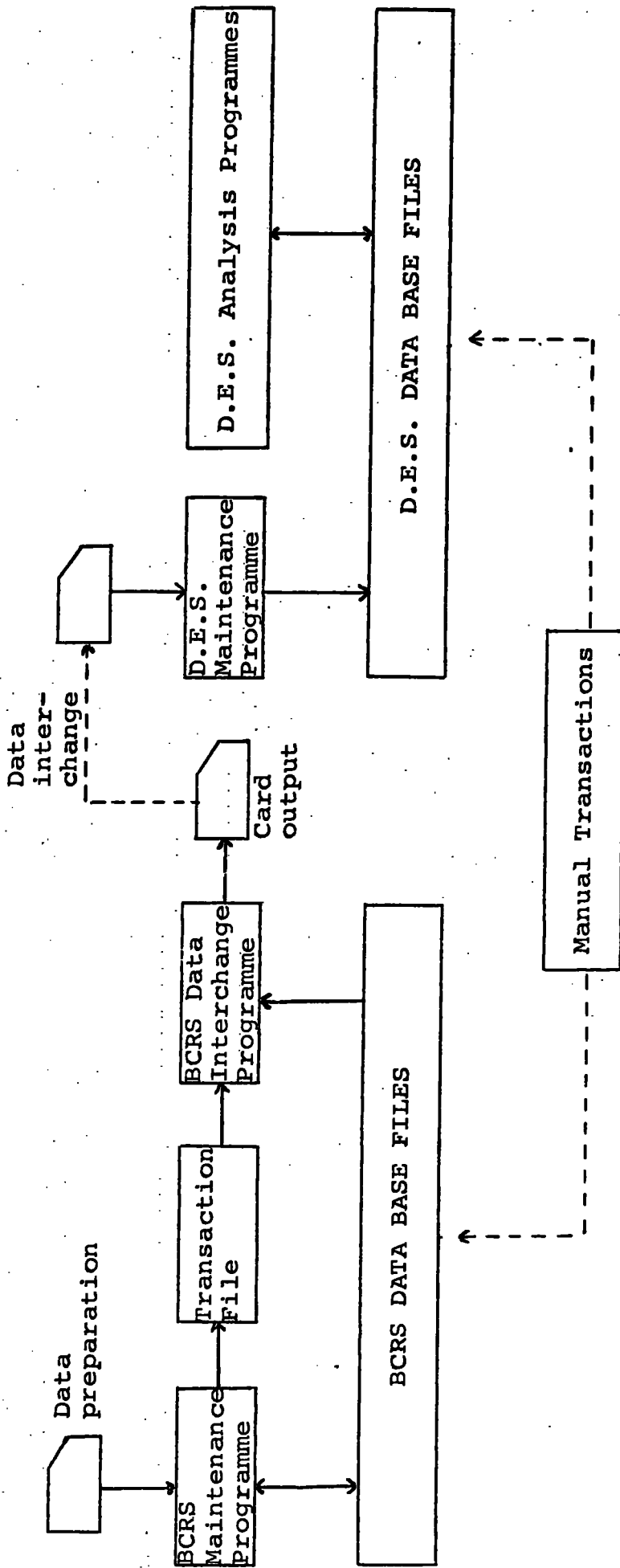

FIGURE 1: The BCRS-D.E.S. Data Interchange

Chapter 5

THE SECURITY OF A DATA MANAGEMENT SYSTEM

When considering the security of a Data Management System two aspects are important. Firstly, the integrity of the system described by Wilkes^[39] as 'the safeguarding by the system of the information entrusted to it', and secondly, the question of privacy and the need to ensure adequate measures against the invasion of that privacy. Until the introduction of Data Management Systems in data processing, many of the existing techniques of data collection, correlation and retrieval provided adequate protection to the information recorded. As Data Management Systems become more widely used, these techniques fail to provide the degree of protection required and different methods have to be developed. In this chapter we shall consider some of the approaches that are being taken to increase the security of these systems.

5.1 INTEGRITY

The use of computers has greatly increased the vulnerability of the data they record. Not only is data being recorded on very sensitive devices, it is also being recorded in larger quantities and to far greater precision. If an accident were to occur, much more information might get corrupted and in many cases it would be both difficult and costly to replace. The integrity of the system concerns the protection of the information recorded either by preventing data corruption or by the restoration of the data files after an error has occurred. The amount of information lost and

the total overhead cost required to restore the system provide a means of measuring the effectiveness of the integrity techniques adopted.

5.1.1 Error Types

There are many error situations which may result in information corruption, for example machine failures, faulty maintenance, programming errors or mis-management. Not all these situations can be detected by hardware or software and certain errors may only be found by providing application orientated consistency checks. Other situations may remain undetected, and if their effect is not trivial the integrity of the files concerned will be lost.

When an error is identified it is sometimes not possible to re-establish the files affected from the original information. For this reason the corrupted files are either reconstructed from previous dumps and journals to the state they would have been in had the error not arisen, or they are restored to their most recent identifiable stage.

Hardware detected errors which may be self-correcting, failure warnings and failure at occurrence errors are detected by circuitry in the system itself. Self-correcting errors require no further action as a temporary correction can be made to the data each time it is referenced or a permanent correction can be made. When a hardware device fails and a failure warning is provided soon enough, the data files can be moved to another device. When a failure warning is given too late or when a hardware device fails without warning, the files affected have to be reconstructed from dumps and journals. In

the latter case, if the error is transient and error correcting routines are successful, no further action need be taken.

Errors which are software detected include content errors, user's errors and some system's errors. Content errors such as improperly coded data items or invalid record keys should not result in the termination of the current task. On the detection of such an error, a warning message should be provided to the user and where the error can be corrected the affected files would have to be reconstructed. In cases where the error cannot be corrected, the files would have to be restored. User's errors leading to the termination of the current task and system's errors such as Operating System failures may require that the files affected be restored, and in both cases automatic system dumps are useful to enable the extent of the data corruption to be quickly ascertained.

The manual detection of errors by operator and user verification procedures can be very important in preventing content and user errors from occurring. In cases where such errors are detected after they have occurred, the files affected would have to be reconstructed if the errors are correctable, and restored when the errors could not be corrected.

5.1.2 File Recovery Techniques

To maintain a high degree of integrity the prevention of errors provides the ideal solution. This however is not always possible since many errors are only detected after data has been corrupted and techniques must then be employed to recover all the damaged information. Recovery techniques can be very complex depending on the files involved and the extent of the damage,

but several measures can be taken to allow the system to recover lost information automatically, or to assist the user to reconstruct or restore affected files.

In some systems where the speed of recovery is important second copies of all files may be kept. The structuring of such copies is also important as the complex data structures used for rapid access during retrieval may not be suitable for restoration purposes. To enable files to be restored quickly, second copies should be maintained in a structure suitable for recovery purposes, whereas elsewhere these files will be structured in a form suitable for the tasks being performed. Second copies of files which are frequently being updated can be conveniently handled by employing father/grandfather techniques, alternatively reading and writing to different files or magnetic tapes. In BCRS this method is used to maintain the integrity of the data files and the tape procedures adopted are discussed in the System Report and User's Manual, page 5, Appendix 2.

Another measure which can be taken to assist in the recovery of corrupted files involves the periodic dumping of all recorded information onto a separate storage medium. If an error subsequently takes place, the affected files can be reconstructed from the state of the last dump. The frequency in which dumps are taken will depend on how often the files concerned are altered, and with large files this technique may involve considerable overheads in running time and cost.

In cases where corrupted files have to be restored or reconstructed, journal tapes provide a useful record of all transactions made. A journal tape consists of a dump of specified information made while the system is in operation.

A transaction journal records a summary of all transactions before they are carried out which may include a record of all key strokes made by operators. Using this information a corrupted file can be restored from a previous dump. Record journals consist of record dumps made before and after each transaction, and they are extremely useful in cases where corrupted records have to be reconstructed. To ensure the integrity of the journal tapes, second copies may be kept and care must be taken to ensure that system failures do not corrupt the journal tapes themselves.

The provision of suitable integrity techniques to cover all error situations is extremely difficult and the measures so far described may in some cases be quite inadequate. The role of the Data Manager is important as he is perhaps the only person who has a complete knowledge of the system. He will have to ascertain what damage has been done by different errors and to identify the best state to which the corrupted files should be restored.

5.2 PRIVACY

Another important aspect involved in the security of Data Management Systems concerns the problem of privacy. Unfortunately the term 'privacy' means different things to different people, but it is generally agreed that some measures must be taken to provide adequate protection against the invasion of privacy, this being particularly desirable in systems where confidential or sensitive data is recorded. The invasion of privacy in computer systems can be both accidental or deliberate and may lead to the misrepresentation of reality by the interpretation of false or corrupt data. For this reason it is important, and a general

ignorance of computers expressed through a topic like privacy could prevent the use of such systems in situations where individuals or society might benefit.

5.2.1 Invasions of Privacy

The problems of providing adequate safeguards against the invasion of privacy are not only confined to computing systems but exist in all situations where confidential and sensitive data is recorded. In computing systems there are several ways in which privacy intrusions may be brought about. The accidental corruption of data for example, by system or user errors, may result in the publication of misleading information, while other errors may have the effect of permitting unauthorised or uncontrolled access to confidential data.

The deliberate abuses of computer based systems can be active or passive. Passive abuses include wire-tapping and electro-magnetic pick-up techniques; active abuses including browsing, masquerading other users, 'between lines' or 'piggy-back' entry, core dumpings, entry by system personnel or via 'trap doors' and the theft of removable data files^[18]. It is virtually impossible to prevent the determined 'user' from abusing the system, but measures can be adopted to make the acquisition of confidential or sensitive data by unauthorised access more difficult.

5.2.2 Counter Measures against Privacy Invasions

The effects of invasions of privacy may be very widespread. The accidental corruption of data may destroy files beyond repair and expensive and time-consuming measures may have to be taken

to re-establish them. Uncontrolled or unauthorised access may have the same effect, or it may result in the misuse of data leading to possible blackmail or the misrepresentation of reality. It is therefore important that adequate safeguards be provided to prevent such intrusions as far as is possible, and to protect individuals and institutions by legislation in situations where privacy is invaded.

Access control provides one counter measure to uncontrolled or unauthorised access. It may be carried out by system procedures for example passwords, voiceprints or fingerprints, or it may be in the form of written authorisation made prior to the release of certain information. This type of control can be placed on individual files or system access as a whole and it offers good protection against the accidental corruption of data unless the error is such that it bypasses or corrupts the password itself. It also provides some protection against browsing where speculative attempts are made to find the correct password from a legitimate source in an attempt to gain unauthorised access.

Processing restrictions such as privileged operations and limited mode terminal use can reduce the amount of data available to unauthorised persons sharing communication lines with authorised users by using 'between lines' or 'piggy back' entry techniques. Restrictions of this nature also reduce the amount of data available to other forms of unauthorised entry, particularly where facilities for protecting specified areas of store are available.

One good method of providing protection against deliberate abuse involves the use of privacy transformations. This technique is based on the scrambling of record keys or sensitive

information by the use of encoders and its subsequent decoding made available only when authorised access is obtained. Substitution, transposition and addition^[18] are three of the main scrambling techniques used. Safeguards of this type may be implemented through hardware and software, but they are expensive and sensitive to system errors, especially transmission errors, which may corrupt the data so badly as to make decoding impossible.

Threat monitoring is another method which can be employed to prevent and deter privacy invasions. This technique involves the continual monitoring of all activity within the system and may be useful in detecting illegal access which, if located early enough, can be traced or cancelled. The main advantage of threat monitoring is that it provides an accurate log of all system activity, but it offers no protection against pick-up techniques or wire-tapping.

The introduction of legislation to safeguard the individual's right of privacy is a complex and difficult problem. It requires an unambiguous definition of what constitutes invasion and what has been invaded; and although several Private Member's Bills have been introduced in Parliament^[32] no legislation yet exists on the position of computers and data banks. The Report of the Younger Committee on Privacy is currently being debated in Parliament and several recommendations have been made on the subject by the British Computer Society^[44]. These recommendations include the recognition of data ownership and suggest imposing restrictions on the use of personal data to safeguard both the persons represented and the users. It also recommends a licensing system for the owners of sensitive data banks

including also those who design, implement and operate such systems.

In BCRS, apart from regular maintenance, all requests for information must be made through the College Representatives. No information where individual identity can be recognised is divulged to outside research groups or individuals, and this information is only available to College research groups after approval has been given by the College Academic Board. Password control is maintained by MTS to prevent unauthorised access to the computer system and the magnetic tapes on which the system is recorded contain volume labels which must be specified when the tapes are mounted. A second copy of all programmes and data records is kept on computer cards. These cards are stored in a separate location from the magnetic tapes and can be used to re-establish the system if any of the tapes are destroyed.

One aspect of security we have not yet mentioned includes the need for safeguards against the complete destruction of computer installations by fire, accident or sabotage. Computers offer good targets for militant political groups and dissatisfied people are quickly learning what to destroy to cause the most disruption. In important installations off-site back-up computers, auxiliary power supplies, riot proof glass and well displayed and frequently tested fire extinguishers may be justified^[35].

5.3 THE RETENTION OF DATA

One problem in many ways associated with the security of Data Management Systems concerns the storing of data for long

periods of time. Data is usually recorded in the manner most suited to its interpretation. For example, data recorded for human interpretation would most probably be represented as printed text, while punched cards or magnetic tapes might be used to record data for machine interpretation. In Data Management Systems where most data is recorded for machine interpretation the choice of recording medium must be given serious consideration. This is especially important if the data is to be stored over a period of several years, during which time deterioration in the quality of the recording, or of the medium itself, may be a source of data corruption.

Printed text provides one of the safest forms in which to retain data, but this representation is inflexible, requiring document readers using relatively slow optical character recognition techniques to re-enter the data if it is required again in machine form. Magnetic tapes are most frequently used but they are very fragile and susceptible to damage. Menkus^[23] suggests that for long term storage, microfilm might prove to be the best medium to use. Compared to magnetic tape it provides a much more stable medium, occupying far less storage space, and its use would release many archive tapes for use in the processing of other data.

REFERENCES

REFERENCES

1. Banbury, J., Unknowns in MIS.
Data Processing, Volume 13, Number 2, 1971
2. Barlow, D.H., Information Retrieval.
The Computer Bulletin, Volume 16, Number 5, May 1972
3. Bridle, J.W. and Gregersen, R.J., CMSR - A Personnel Information System.
The Computer Journal, Volume 14, Number 4, November 1971
4. Broderick, W.R. and Bryant, M.E., FDS/File Description System.
The Computer Bulletin, Volume 16, Number 2, February 1972
5. Byrnes, C.J. and Steig, D.B., File Management Systems: A Current Summary.
Datamation, Volume 15, Number 11, November 1969
6. Climenson, W.D., File Organisation and Search Techniques.
Annual Review of Information Science and Technology, Volume 1, 1966
7. Codd, E.F., A Relational Model of Data for large Shared Data Banks.
Communications of the ACM, Volume 13, Number 16, June 1970
8. Coulouris, G.F., Evans, J.M. and Mitchell, R.W., Toward Content-Addressing in Data Bases.
The Computer Journal, Volume 15, Number 2, May 1972
9. Dearden, J., How to Organise Information Systems.
Management Information Systems, edited by McRae, T.W., Penguin Modern Management Readings
10. Dee, E.G., Aspects of Data Base Management (2).
Data Processing, Volume 13, Number 2, 1971
11. Dodd, G.G., Elements of Data Management Systems.
Computing Surveys, Volume 1, Number 2, June 1969
12. Drake, R.W. and Smith, J.L., Some Techniques for File Recovery.
The Australian Computer Journal, Volume 3, 1971, pp.162-170
13. Fry, J. and Gosden, J., Survey of Management Information Systems and their Languages.
Critical Factors in Data Management, edited by Gruenberger, F., pp.41-55, Prentice-Hall Inc., Englewood Cliffs, N.J.
14. Fry, J., Bramson, S. and Fried, D.C., Data Management Systems Survey.
Mitre Corporation, January 1969
15. Giles, P., A Low Cost Enquiry-orientated Data Base.
The Computer Bulletin, Volume 15, Number 4, April 1971

16. Hasio, D. and Harary, F., A Formal System for Information Retrieval from Files.
Communications of the ACM, Volume 13, Number 2, February 1970
17. Hebditch, D.L., A Simple Terminal Language for a Data Base.
The Computer Bulletin, Volume 16, Number 1, January 1972
18. Hoffman, L.J., Computers and Privacy: A Survey.
Computing Surveys, Volume 1, Number 2, June 1969
19. Holland, S.A., The Remote Inquiry of Data Bases.
Datamation, Volume 16, Number 15, November 15 1970
20. Langefors, B., Elementary Files and Elementary File Records.
Proceedings of the IFIP Congress, Edinburgh, 1968
21. Lefkovitz, D., File Structures for on-line Systems.
Spartan Books, New York, Washington
22. Lowe, T.C., The Influence of Data Base Characteristics and Usage on Direct Access File Organisation.
J.ACM, Volume 15, Number 4, October 1968, pp.535-548.
23. Menkus, B., Retention of Data for the Long Term.
Datamation, Volume 17, Number 18, September 15 1971
24. Olle, T.W., UL/1: A non-procedural Language for retrieving Information from Data Bases.
Proceedings of the IFIP Congress, Edinburgh, 1968, pp.572-578
25. Olle, T.W., MIS: Data Bases
Datamation, Volume 16, Number 15, November 15 1970
26. Phillips, M., Experience in setting up the National Computer Program Index and Related Files.
Proceedings of the IFIP Congress, Edinburgh, 1968
27. Prywes, N.S., Structure and Organisation of very large Data Bases.
Critical Factors in Data Management, edited by Gruenberger, F., pp.127-146, Prentice-Hall Inc., Englewood Cliffs, N.J.
28. Reynolds, C.F., CODIL, Man-Computer Interaction.
IEE Conference Publication, Number 68, 1970, pp.211-217
29. Reynolds, C.F., CODIL, Part 1. The Importance of Flexibility.
The Computer Journal, Volume 14, Number 3, August 1971
30. Reynolds, C.F., CODIL, Part 2. The CODIL Language and its Interpreter.
The Computer Journal, Volume 14, Number 4, November 1971
31. Roberts, D.C., File Organisation Techniques.
Advances in Computers, Volume 12, 1972, Academic Press, New York, London, 1972
32. Sizer, T.R.H., Privacy and the Computer.
The Computer Bulletin, Volume 16, Number 8, August 1972.

33. Smith, J.M., Aspects of Data Management (1).
Data Processing, Volume 13, Number 2, 1971
34. Stross, C.O.M., Operation of a Disc Data Base.
The Computer Journal, Volume 15, Number 4, November 1972
35. Van Tassel, D., A Contingency Plan for Catastrophe.
Datamation, Volume 17, Number 13, July 1 1971
36. Vose, M.R. and Richardson, J.S., An Approach to Inverted
File Maintenance.
The Computer Bulletin, Volume 16, Number 5, May 1972
37. Warheit, I.A., The Direct Access Search System.
AFIPS Conference Proceedings, Volume 24, 1963
38. Wessler, J., Myers, E. and Gardner, W.D., Physical
Security .. Facts and Fancies.
Datamation, Volume 17, Number 13, July 1 1971
39. Wilkes, M.V., On Preserving the Integrity of Data Bases.
The Computer Journal, Volume 15, Number 3, August 1971
40. Wormeli, P.K., The Search for Automated Justice.
Datamation, Volume 17, Number 12, June 15 1971
41. Introduction to 'Feature Analysis of Generalised Data
Base Management Systems'.
Communications of the ACM, Volume 14, Number 5, May 1971
42. Data Base Task Group Report to the Codasyl Programming
Language Committee, April 1971
43. IFIP Guide to Concepts and Terms in Data Processing.
Edited by Gould, I.M., North Holland Publishing Company,
Amsterdam, London
44. Submission of Evidence to the Committee on Privacy.
The Privacy Committee of the BCS, The Computer Bulletin,
Volume 15, Number 5, May 1971
45. The Strategy of File Organisation, Symposium Summary.
Proceedings of IFIP Congress, Volume 2, 1965, pp.460-467,
Spartan Books, Washington D.C., MacMillan and Co. Ltd.,
London
46. IBM System/360 Operating System, PL/1 Language Reference
Manual, Form C28-8201
47. IBM System/360 Operating System, PL/1 Subroutine Library,
Program Logic Manual, Form Y28-6801
48. IBM System/360 Operating System, PL/1 Programmer's Guide,
Order No. GC28-6594

Appendix 1

Techniques of File Organisation

1.1 Sequential Organisation

1.2 Random Organisation

1.2.1 Direct Address

1.2.2 Dictionary Lookup

1.2.3 Address Calculation

1.3 List Organisation

1.3.1 Simple List

1.3.2 Inverted List

1.3.3 Rings

1.4 Tree Structures

Appendix 1

TECHNIQUES OF FILE ORGANISATION

There are three main file organisation techniques in use today: sequential organisation, random organisation and list organisation.

To illustrate each type let us consider a set of records containing the following information:

Reference Number

Name

Date of Birth

Marital Status (coded 1 to 3)

Religion (coded 1 to 5)

Area of Settlement (coded 1 to 6)

Geographical Region of Origin (coded A to K)

where the codes adopted might be similar to those given on pages 94 and 95 of the System Report and User's Manual, Appendix 2.

A typical set of records could be:

| Rec. No. | Ref. No. | Name | Date of Birth | Marital Status | Religion | Area | Region |
|----------|----------|----------------------|---------------|----------------|----------|------|--------|
| 1 | 7142120 | Bailey, Angus | 04/04/54 | 1 | 1 | 4 | F |
| 2 | 7242051 | Cards, John | 02/12/53 | 1 | 3 | 5 | J |
| 3 | 7242052 | Williamson, Anthony | 23/11/52 | 1 | 1 | 6 | K |
| 4 | 7242053 | Gold, Clarissa | 29/10/53 | 2 | 2 | 2 | D |
| 5 | 7242061 | Herries, John Robert | 08/09/54 | 1 | 2 | 3 | C |
| 6 | 7242062 | Trenchard, Kate | 02/12/53 | 2 | 2 | 2 | J |

1.1 SEQUENTIAL ORGANISATION

In a file with sequential organisation the records are arranged in a sequence which may depend on the value of some field within the records or on the order in which the records

arrived in the file. Figure 1 shows the records arranged in ascending order of Reference Number.

| | | | | | | | | | | | | |
|---------|---------------|--------|---|---|---|---------|-----------------|-------------|--------|---|---|---|
| 7142120 | Bailey, Angus | 040454 | 1 | 1 | 4 | F | 7242051 | Cards, John | 021253 | | | |
| | | | 2 | 3 | C | 7242062 | Trenchard, Kate | 021253 | 2 | 2 | 2 | J |

FIGURE 1: Sequential Organisation

Sequential organisation permits rapid access to successive records, but retrieval of out of sequence records can be slow and will depend on the number of records in the file and the position of the required record.

1.2 RANDOM ORGANISATION

In a file with random organisation a relationship is established between the key of a record and the address where that record is recorded. To provide access to the records three methods are used: direct address, dictionary lookup, and address calculation.

1.2.1 Direct Address

Direct addressing techniques can be used when the address of a record is known. This address can then be used directly to access the required record. In the example file the Reference Numbers uniquely identify each record and could be used as a means of direct addressing.

1.2.2 Dictionary Lookup

A dictionary lookup technique can be used when no direct relationship exists between the key of a record and its address in storage. Typically a dictionary consists of two entries per record, a key and an address. To access a specified record the key must first be located in the dictionary. The corresponding entry then provides the required address. Figure 2 provides an example of a dictionary based on surnames arranged in alphabetical order.

| | |
|------------|---|
| Bailey | 1 |
| Cards | 2 |
| Gold | 4 |
| Herries | 5 |
| Trenchard | 6 |
| Williamson | 3 |

FIGURE 2: Dictionary based on Surname

The efficiency of the dictionary lookup methods depends on the size of the dictionaries and the search technique used to locate the required key. Large dictionaries which cannot be held in core are often segmented to produce a hierarchy of smaller dictionaries, the most frequently referenced of which are located in core. This type of organisation is discussed later when considering tree structures. Where the dictionary keys can be maintained in some collating sequence a binary search technique can be used to locate the required key. This technique is far more efficient than the sequential scan of the dictionary keys which would be required if no collating sequence was maintained.

1.2.3 Address Calculation

In the address calculation method the address of a record

is found by performing some simple calculations on the record key. This technique however does not always produce unique addresses as two or more keys could yield the same address. In this case a collision is said to have occurred and several records may have to be retrieved and the keys compared in full until the correct record is found. The efficiency of this method is greatly reduced when a collision occurs as very often a large number of processing steps are required to ensure that the correct record is located.

1.3 LIST ORGANISATION

In list organisation pointers maintain the logical organisation of the records within a file. The three main types of list organisation are the simple list, the inverted list and the ring.

1.3.1 Simple List

A simple list organisation is provided in Figure 3 where the records are linked by the use of pointers in alphabetical order of surname. A record with a pointer of \emptyset terminates the list.

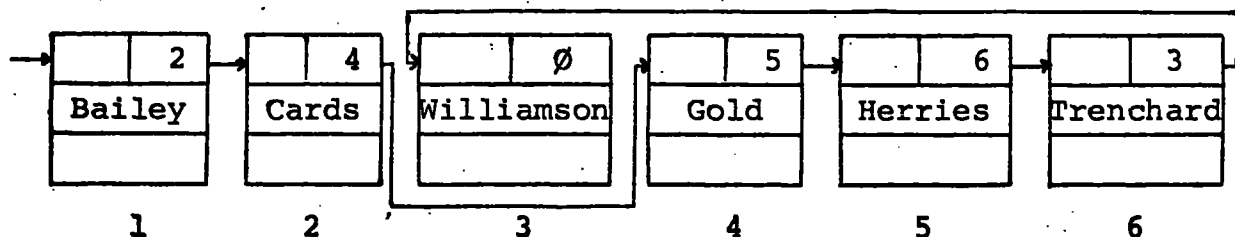

FIGURE 3: A Simple List Organisation

In this example only one record field has been used as a key to provide the list pointers, but where several fields are used as keys there may be many lists linking each record.

Figure 4 shows a partially inverted file based on Religion. In this case an index provides the first record for each coded value and all the records with the same value are then linked with simple list pointers.

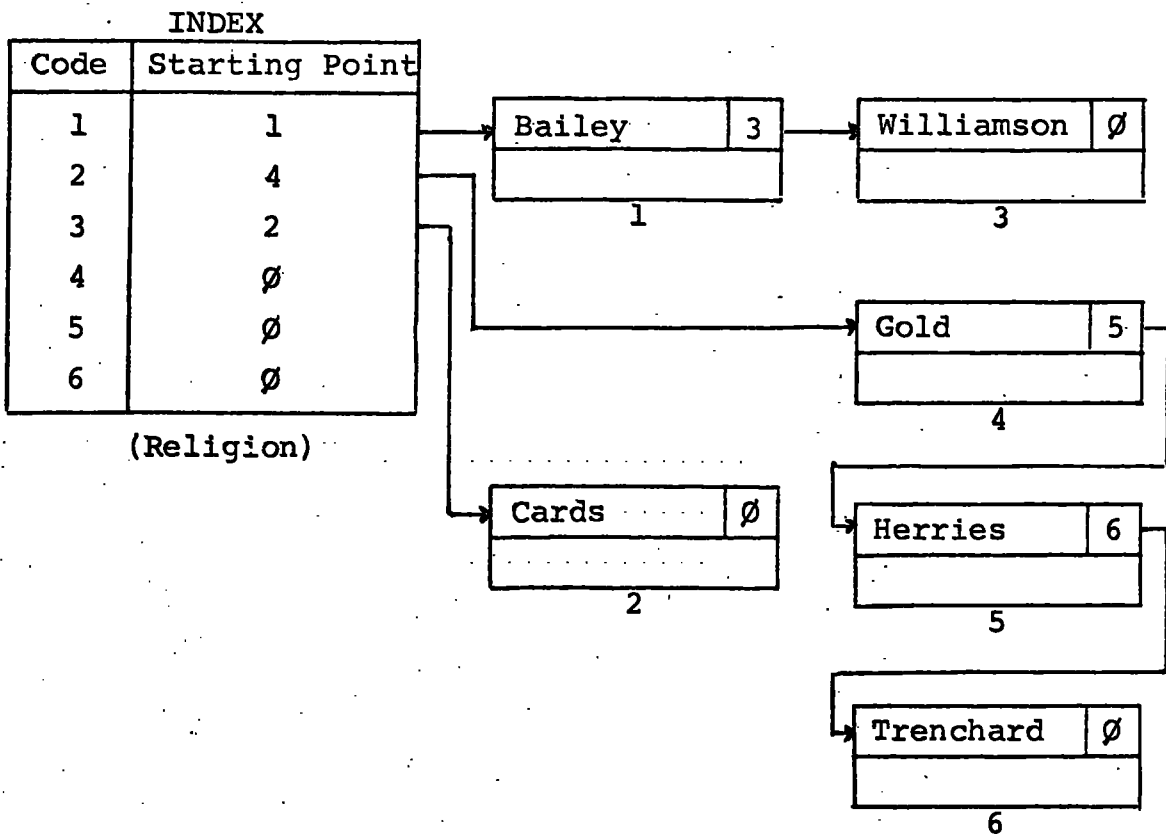

FIGURE 4: A Partially Inverted List based on Religion

1.3.2 Inverted List

An inverted file consists of an inverted list for each recorded value of all keyed fields. In Figure 5 all recorded values have been used to provide a fully inverted file. Using this organisation, access can be made very quickly to required records and in many cases users' requests can be answered directly from the inverted file without requiring the actual

records themselves to be retrieved.

Consider as an example a request of the form: how many students have a Marital Status code of 1? The answer, four, can be obtained by counting the number of entries contained in the inverted list corresponding to Marital Status code 1.

| | | | | | | |
|----------------|---------|----------------------|------------|---------------------|-----------------------|-----------------|
| 714212Ø | 7242Ø51 | 7242Ø52 | 7242Ø53 | 7242Ø61 | 7242Ø62 | (Ref. No.) |
| 1 | 2 | 3 | 4 | 6 | 6 | |
| Bailey, Angus | | Cards, John | | Williamson, Anthony | | (Name) |
| 1 | | 2 | | 3 | | |
| Gold, Clarissa | | Herries, John Robert | | Trenchard, Kate | | (Name) |
| 4 | | 5 | | 6 | | |
| Ø4Ø454 | Ø21253 | 231152 | 291Ø53 | Ø8Ø954 | | (Date of Birth) |
| 1 | 2,6 | 3 | 4 | 5 | | |
| 1 | 2 | (Marital Status) | | | | |
| 1,2,3,5 | 4,6 | | | | | |
| 1 | 2 | 3 | (Religion) | | | |
| 1,3 | 4,5,6 | 2 | | | | |
| 2 | 3 | 4 | 5 | 6 | (Area of Settlement) | |
| 4,6 | 5 | 1 | 2 | 3 | | |
| C | D | F | J | K | (Geographical Region) | |
| 5 | 4 | 1 | 2,6 | 3 | | |

FIGURE 5: Inverted Organisation

Although fully inverted files provide easy access to all records, in many cases the inverted lists become larger than the

records themselves. Further difficulties can also be encountered during record maintenance as the addition of new records will require field key values to be inserted in the inverted lists. The usual methods adopted are to physically insert the new field keys in their correct locations, moving existing field keys where necessary, or by inserting them at the end of each list and maintaining pointers to ensure the correct logical order. Other methods such as the substituting of ascending numbers for field keys and the provision of cross reference index tables^[36] can also be used. In all cases the time taken to maintain the field keys required to support this type of organisation makes its use uneconomical in situations where a large volume of record updates have to be processed.

1.3.3 Rings

A ring structure consists of a simple list where the last record points back to the start of the list. Figure 6 shows a simple ring structure based on Reference Number and in this case the start of the ring is also recorded.

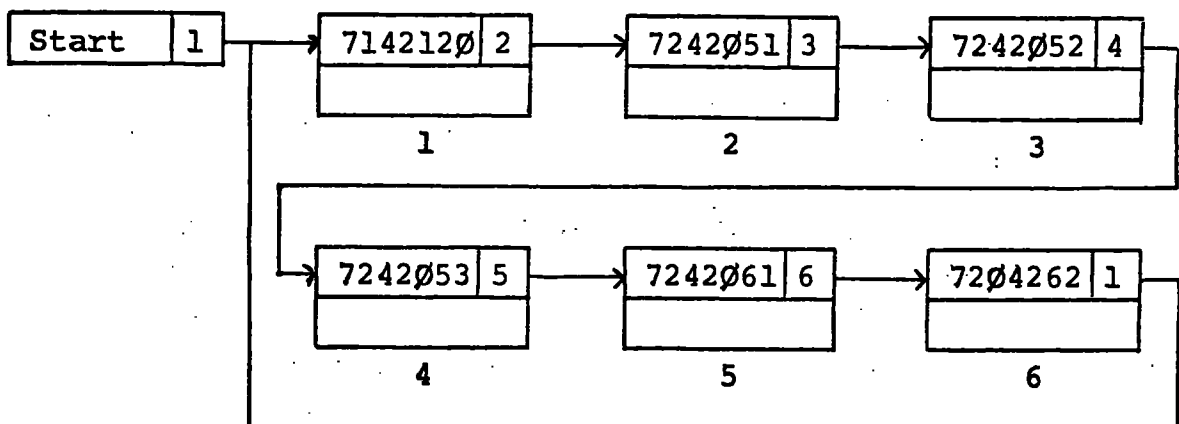

FIGURE 6: A simple Ring List based on Reference Numbers

In Figure 7 a ring structure based on Religion is shown. All the records with the same code are linked and the codes available are also linked.

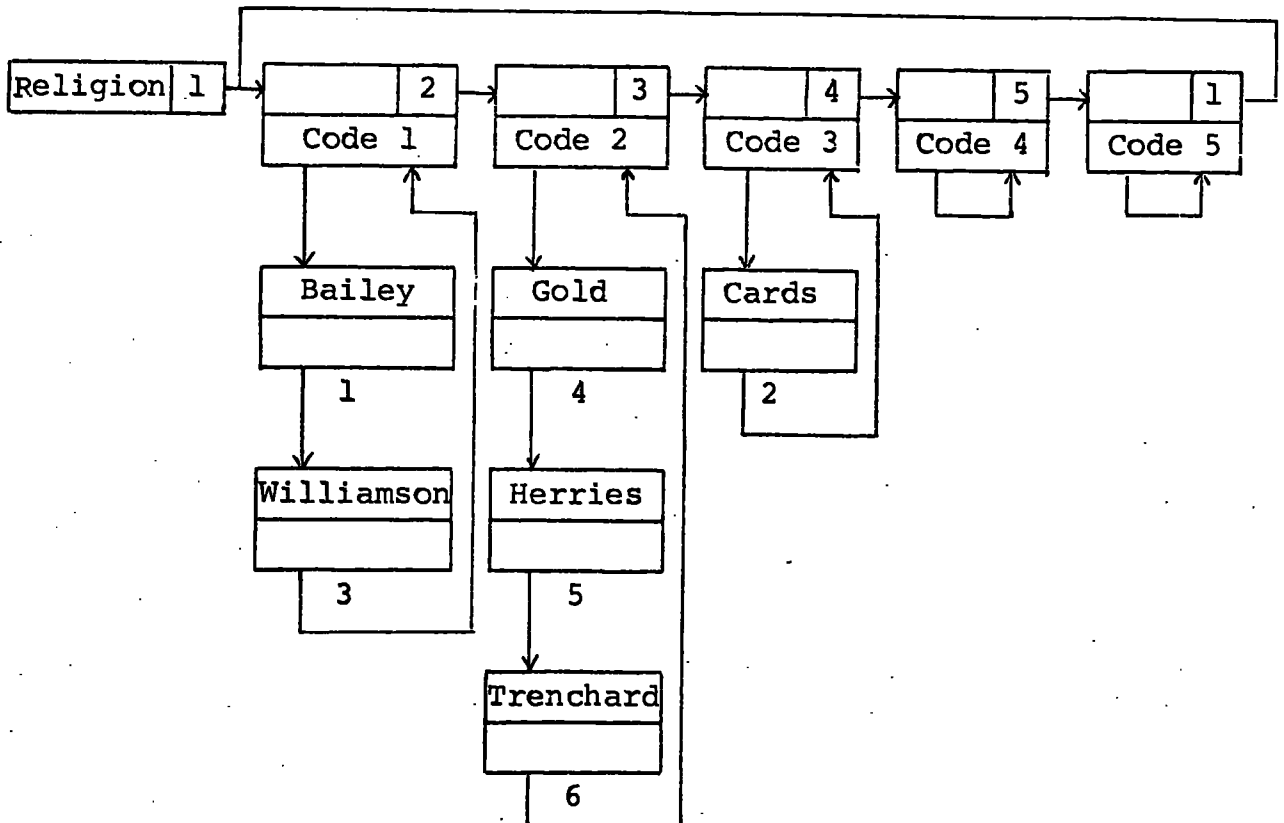

FIGURE 7: A Ring List based on Religion

In cases where several rings pass through each record, the pointer maintenance required to maintain the desired logical order can be very complex and record pointers are often recorded printing backwards to the previous record in the ring, or to the starting record of each ring. These cases are sometimes known as Coral ring structures^[11]. A ring structure can be very useful as it allows the retrieval of records in one ring to be carried out, branching where necessary round other rings of related information.

The main disadvantages with all forms of list organisations involve the time taken for pointer maintenance and the space

overheads required to record the pointers.

1.4 TREE STRUCTURES

Tree structures are similar to dictionaries as they are usually used to provide key to address transformations. In Figure 8 a symbol tree structure is shown. This structure is formed from the student Reference Numbers, and the leaf nodes of each branch contain the address of the record represented by that branch. For example, the branch 7-2-4-2- \emptyset -5-3 provides the address (4) of the record 7242 \emptyset 53, whereas the branch 7-2-4-2- \emptyset -6-1 provides the address of the record 7242 \emptyset 61.

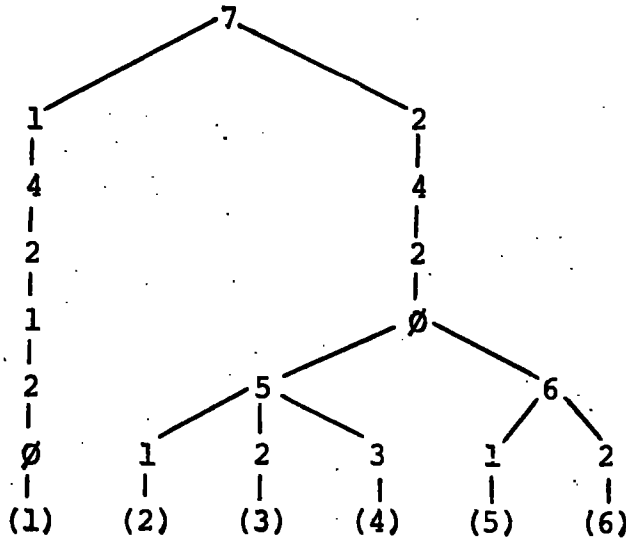

FIGURE 8: A Symbol Tree Structure based on the Reference Number

Directory tree structures can be useful in cases where dictionary tables are too large to be held in core. Consider the dictionary table shown in Figure 9. This table can be divided into three smaller dictionary tables, also shown, forming what is known as a directory tree.

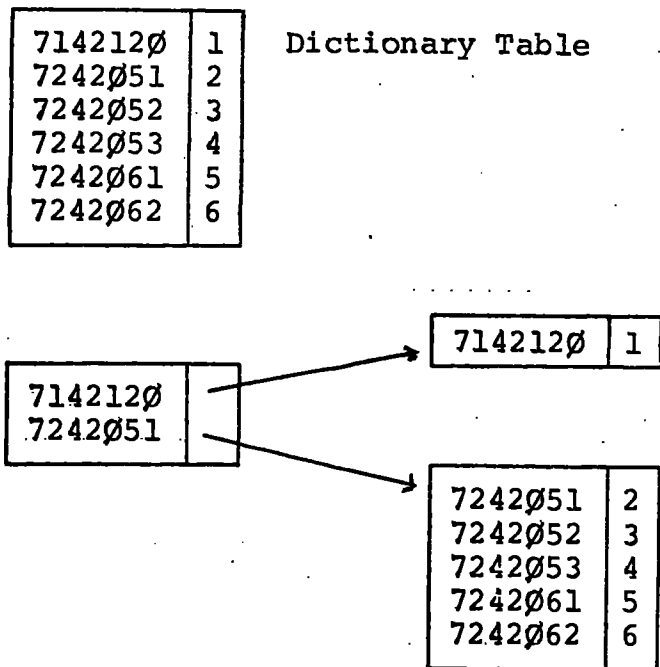

FIGURE 9: A Dictionary and a Directory Tree Structure based on Reference Numbers

In this case the first two digits of the Reference Number have been used to provide the tree levels. Using the first two and the last two digits, the dictionary table can be divided further, giving the three level directory tree shown in Figure 1Ø.

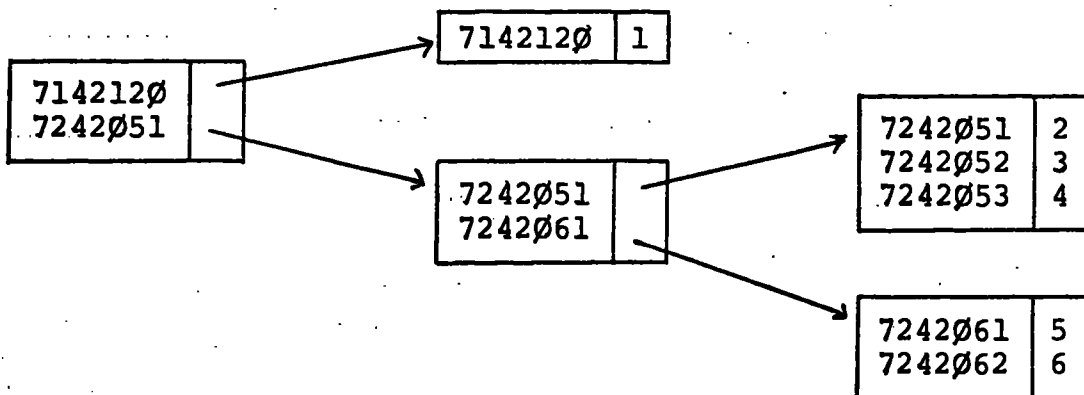

FIGURE 1Ø: A three level Directory Tree Structure based on Reference Numbers

The minimisation of the search time required to locate a specified record is one of the problems encountered with all forms of tree structures. The most commonly used methods are the sequential scan and the binary search, although various other methods can be used^[31].

The file organisation techniques discussed in this Appendix do not form an exhaustive list as many hierarchical data structures can be derived from each of the basic methods described. A considerable amount of literature about organisation techniques and search strategies is available and both Roberts^[31] and Climenson^[6] contain good bibliographies on this topic.

Appendix 2

BCRS....Bede College Record System

System Report and User's Manual

This Appendix contains a report of the BCRS system. This report describes the system and provides a user's manual for those intending to use it.

BCRS BEDE COLLEGE RECORD SYSTEM

SYSTEM REPORT and USER'S MANUAL

ABSTRACT

Bede College Record System (BCRS) is a Data Management System for recording and maintaining student records in data base files.

The system consists of a suite of PL/1 (Programming Language 1) programmes designed to run on the NUMAC IBM 360/67 computer under MTS (Michigan Terminal System) in batch mode.

This report describes the system and provides a user's manual for those intending to use it.

BEDE COLLEGE RECORD SYSTEM

C O N T E N T S

| | Page |
|--|------|
| 1. INTRODUCTION | 1 |
| 2. AN OUTLINE OF BCRS | 2 |
| 2.1 Terminology | |
| 2.2 The BCRS Programmes | |
| 2.3 The BCRS Data Files | |
| 2.4 BCRS Tape Formats | |
| 2.5 BCRS Tape Procedures | |
| 2.6 The Data Constants File | |
| 3. INFORMATION RECORDED | 10 |
| 3.1 Record Card | |
| 3.2 Intelligence Test Scores | |
| 3.3 Implementation Restrictions | |
| 3.4 Default Field Settings | |
| 3.5 Data Checking Procedures | |
| 4. PROGRAMME OPTIONS | 15 |
| 4.1 Programme Options programme R | |
| 4.2 Programme Options programme F | |
| 4.3 Programme Options programme I | |
| 4.4 Programme Transactions programme D | |
| 5. THE OPTION PARAMETER CARD | 24 |
| 6. DATA PREPARATION FOR PROGRAMME R | 44 |
| 7. DATA INTERCHANGE PROCEDURES AND SCHEDULES | 45 |
| Appendix 1 | |
| 1.1 Bede College Personal Record Card (1972) | 49 |
| 1.2 Course Results | |
| 1.3 D.E.S. Form 30 T.T. | |
| Appendix 2 BCRS DATA CARD FORMATS | 59 |
| 2.1 Record Admissions card format | |
| 2.2 Record Updating card format | |
| 2.3 Intelligence Tests card format | |
| 2.4 Withdrawals card format | |
| 2.5 Course/Subject Changes card format | |
| Appendix 3 D.E.S. DATA INTERCHANGE CARD FORMATS | 69 |
| 3.1 Card Output admissions | |
| 3.2 Card Output withdrawals | |
| 3.3 Card Output change of course/subject | |
| 3.4 Card Output re-admissions | |
| 3.5 Card Output end of course | |
| Appendix 4 BCRS ERROR/WARNING MESSAGES | 79 |
| Appendix 5 CODE LISTINGS | 86 |
| 5.1 Authority/Country | |
| 5.2 General Codes | |
| 5.3 Qualification Codes adopted by the College | |
| 5.4 Subject Codes adopted by the College | |
| 5.5 A'level Codes and Corresponding Card Columns | |
| 5.6 Other Relevant Qualification Codes | |

1. INTRODUCTION

Bede College Record System (BCRS) is a computer based Data Management System for recording and maintaining student records in Data Base files.

The information forming a student record is taken from the Bede College Personal Record Card, and this information together with the results of several Intelligence Tests undertaken by the students is recorded in a file corresponding to the year of admission of the student to the College.

The BCRS suite of programmes provides a Data Management System for the establishment and maintenance of the Data Base files, and for the Data Interchange System between the College and the Department of Education and Science at Darlington.

Facilities are also included for providing frequency tables on much of the information recorded within the files, and on the results of the Intelligence Tests. Such tables may be obtained for the whole population of any specified file, or for a wide range of subsets of that population as selected by the user.

The programmes and data files forming BCRS are stored on Magnetic Tape. The programmes are written in PL/1 (Programming Language 1), and designed to run under MTS (Michigan Terminal System) in batch mode. In order to understand how to use these programmes it is essential that the user has some knowledge of BCRS and the MTS Command Language. This report outlines BCRS. For a knowledge of the Command Language reference should be made to the following documents available from the Computer Unit Reception:

1. NUMAC Users Manual, MTS Section
2. NUMAC Programming Notes 9, 23 and 33

2. AN OUTLINE OF BCRS

Before discussing BCRS let us first define some of the terminology which will be used.

2.1 TERMINOLOGY

1. MTS FILES

In MTS a file is an area of computer storage named by the user. There are two kinds of files classified by their organization....

1. LINED FILES
2. SEQUENTIAL FILES

All MTS files regardless of their organization belong to one of three types....

1. PRIVATE FILES
2. TEMPORARY FILES
3. PUBLIC FILES

2. LINED FILES

A Lined file consists of an ordered set of zero or more lines, each line capable of containing from 1 to 255 characters. A line number is associated with each line, thus giving access to individual lines.

3. SEQUENTIAL LINES

A Sequential file consists of a sequence of records each capable of containing from 1 to 32767 characters. Such files may only be accessed sequentially.

4. PRIVATE FILES

Private files, otherwise known as USER FILES or PERMANENT FILES, must be created and destroyed explicitly by the user. Such files will after they have been created remain in the system until they are destroyed. Their names may consist of from 1 to 12 alphanumeric characters (i.e. characters in the range A to Z and 0 to 9).

5. TEMPORARY FILES

Temporary files are sometimes known as SCRATCH FILES, and they are in existence only for the duration of time that the user is active on the system. They are automatically created by the system as LINED FILES the first time they are mentioned and are similarly destroyed automatically by the system when the user Signs Off. They may be created and destroyed explicitly in the same manner as Private files. The first character of a temporary file is always the minus sign which must be followed by from 1 to 8 alphanumeric characters.

6. PUBLIC FILES

Public files are sometimes known as LIBRARY FILES and are systems files available to all users. The first character of their names is always an asterisk and they may be accessed by any user but not modified.

7. PSEUDO-DEVICE NAMES In MTS the input and output units (i.e. card readers, card punches, line printers and others) are known as devices. These devices are assigned names known as Pseudo-device names. Later we shall see where MTS uses pseudo-device names. The first and last character of a pseudo-device name is always the character asterisk.
8. READ/WRITE HEADS These are part of the Magnetic TAPE STATION or TAPE DECK used to READ (i.e. sense the magnetisation of) the tape, and WRITE onto (i.e. magnetise) the tape.
9. BLOCKS These are magnetised areas of magnetic tape. They may be DATA BLOCKS or TAPEMARKS. Data blocks contain information (programmes and data), while tapemarks serve to delimit groups of related data blocks.
10. GAPS Gaps are unmagnetised areas of magnetic tape separating blocks. The initial gap on the tape is known as BT (Beginning of Tape) and the final gap is known as ET (End of Tape).

2.2 THE BCRS PROGRAMMES

The programmes which form BCRS are known as R, F, I and D, see Figure 1, page 7. Programme R is the main programme and is responsible for the establishment and maintenance of the data base files. This programme provides the user with a series of OPTIONS each performing one or more tasks in the Data Management System. Programme R is the only programme in BCRS which allows the user to alter or update records within a specified file. When this has been done, however, the new updated file CANNOT be copied back to its original block on the tape since this would most certainly partially erase the following blocks. How this problem is overcome is discussed in 2.5, page 5.

When card output for the Data Interchange System is required, programme R establishes a TRANSACTION FILE containing the D.E.S. Nos. and the required interchange transactions. This Transaction file is used together with the specified records by programme D and card output for D.E.S. produced.

Programmes F and I which produce frequency tables also provide the user with a series of options. Programme F handles the record information, and programme I the Intelligence Test information. These programmes, like programme D, have read-only access to the data files, i.e. they can read the files but not modify them.

When running one of the BCRS programmes R, F or I, the user may select any number of options by providing as input an OPTION PARAMETER CARD. This card which is explained in Section 5 informs BCRS which data file is to be used and which option is requested. It also contains several control PARAMETERS required by the selected option.

With programme R this card may be followed by records or amendments depending on the selected option, and as a title to the output listings for all options BCRS will provide a verification of the information appearing on the Option Parameter Card.

The programme options available are discussed in Section 4.

2.3 THE BCRS DATA FILES

BCRS data files contain the records of the students admitted to the College since 1969. The records are grouped in files corresponding to the year of admission of the student to the College.

The records of students who withdraw from the College are maintained and the reason for withdrawal recorded. If a student who has withdrawn is then re-admitted in a subsequent year, a new record is established in the file corresponding to the year in which the student was re-admitted.

The files are organized sequentially and the information recorded in each record is discussed in Section 3.

2.4 BCRS TAPE FORMATS

Although BCRS is stored on Magnetic Tape, the system is designed to use MTS disc files. This means that before using BCRS the required information (programmes and data files) must be copied from the tape to disc files.

Two copies of BCRS are kept on separate tapes. To run the system we must first MOUNT the most up-to-date tape, further discussion on this is given in 2.5. When the tape has been mounted the read/write heads of the tape deck will be in the position BT, see figure 3, page 9. We can now copy the required blocks of information from the tape into MTS files. Programmes should be copied to MTS Lined files, but data blocks MUST be copied to Sequential files since each record is greater than 255 characters. In either case Temporary files may be used.

When BCRS was established on tape the information (programmes and data files) were grouped into blocks. This grouping represents the format in which the tape data blocks are to be interpreted as logical records, and the logical records as file lines or physical records (and vice versa). As this grouping differs between the programme blocks and the data file blocks, we must ensure that the correct unblocking procedure is specified before attempting to read from the tape, and that the correct blocking procedure is specified when writing to the tape.

The format of the tape blocks may be specified either when the tape is mounted or later by use of the Carriage Control Codes SRL, REC and LRC.

The following table gives the parameters required in the mount command to specify the format of the tape blocks:

| Programme block format | Data file block format |
|---|----------------------------------|
| Cl00 or SIZE=8000 RECF=FB LREC=80 | SIZE=2416 RECF=F LREC=2416 |

Note that when specifying the format for the programme blocks Cl00 may be used. This is equivalent to 100 card images, i.e. SIZE=8000, RECF=FB, LREC=80.

If the format has to be changed after the tape has been mounted, the Carriage Control Codes in the following table should be used:

| Programme block format | Data file block format |
|------------------------------|-------------------------------|
| SRL 8000 REC FB LRC 80 | SRL 2416 REC F LRC 2416 |

The meanings of the mount parameters and the Carriage Control Codes are as follows:

- SIZE and SRL : This sets the buffer size, i.e. the maximum size of a tape block.
- RECF and REC : This sets the tape format code, specifying Fixed or Fixed Block records.
- LREC and LRC : This sets the maximum line or physical record length.

2.5 BRCS TAPE PROCEDURES

The two tapes containing the copies of BCRS were established with the Volume Labels **██████A** and **██████B**. We must allocate pseudo-device names to these tapes when they are being mounted. Let us assume that the pseudo-device names given to the tapes are *A* for **██████A** and *B* for **██████B**, and that *A* is the most up-to-date tape.

The following steps outline the tape procedures which should be adopted in order to preserve the integrity of the system.

A. When updating files

1. Mount tape *A* specifying an unblocking format of Cl00, and a read-only permit (RING=OUT). This ensures that any attempts by the user to write to the tape will be prevented by the computer system.

2. Copy the required programme blocks from the tape to MTS disc files.
3. Change the unblocking format by use of the Carriage Control Codes SRL, REC and LRC to enable data file blocks to be read.
4. Copy the required data file blocks to MTS SEQUENTIAL disc files.
5. Perform task(s).
6. Mount tape *B* specifying a blocking format of SIZE=2416, RECF=F and LREC=2416, and a read/write permit (RING=IN). This allows the user to read from or write to the tape.
7. Copy the data files to tape *B* from either the MTS disc files or from *A*.
8. Rewind and dismount the tapes *A* and *B*.

It should now be noted that the most up-to-date tape is tape *B*.

B. When not updating files

When not updating files the MTS disc files used need not be copied back to the tape. The steps now become 1 to 5 as in case A above, and finally step 6 as:

6. Rewind and dismount tape *A*.

These procedures are given diagrammatically in Figure 2, page 8.

In adopting these procedures the user always ensures that one copy of BCRS is always safe from accidental destruction or erroneous update. The programmes and data files can be re-established from cards since all card input records and amendments are kept, but this is an expensive and time consuming process.

2.6 THE DATA CONSTANTS FILE

The Data Constants file contains codes and tables required by certain of the options in programmes R, F and D. The format of the file blocks correspond to those of the programme blocks (i.e. Cl00), and the file contains the following information:

1. The Authority/Country Names and their corresponding codes.
2. The General codes.
3. The A'level codes and their corresponding Form 30 T.T. card columns.
4. The Tables of Norms for College Students.

This file should be copied from tape to an MTS Lined file and made available to those BCRS programmes which require it.

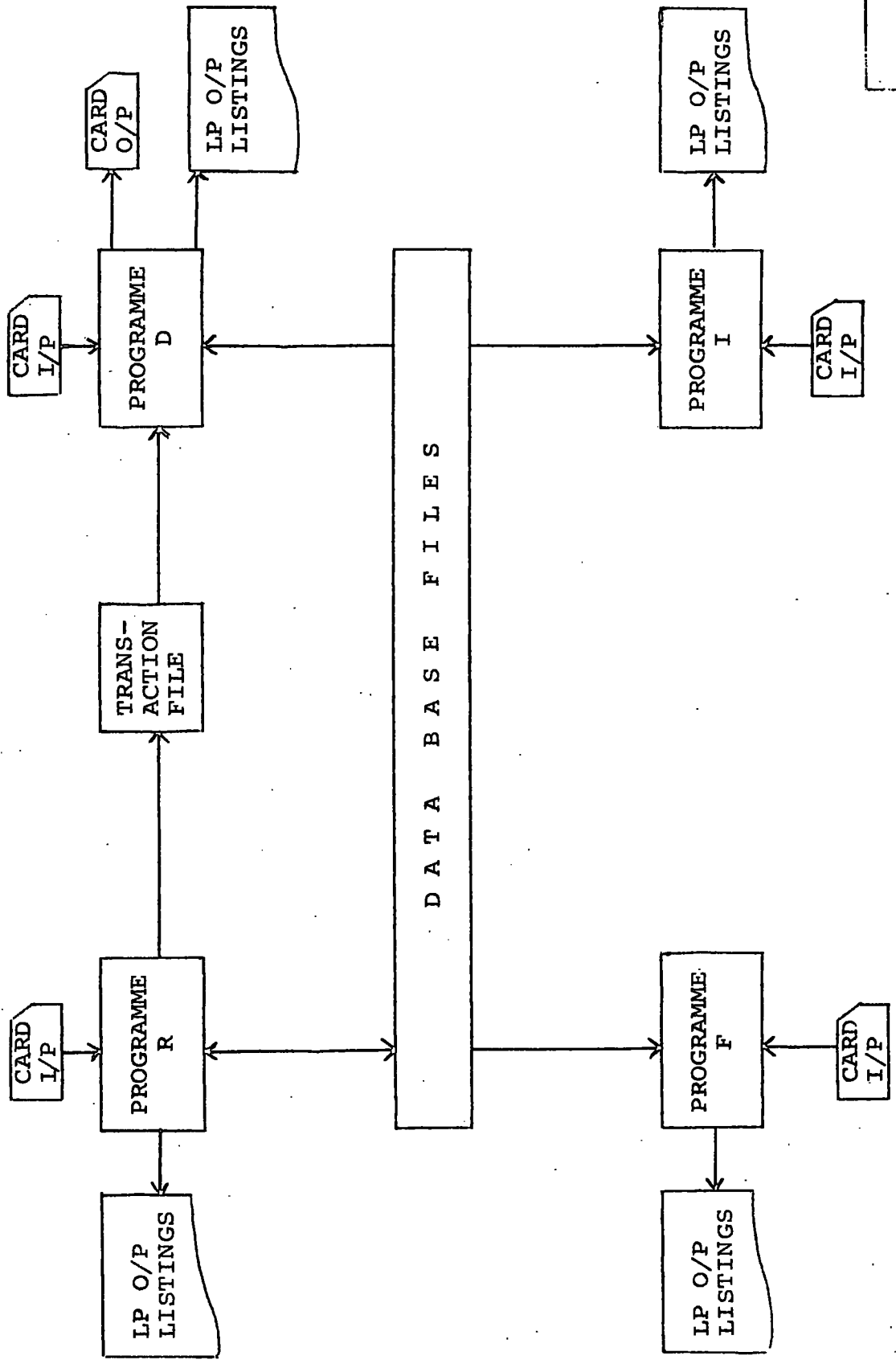

KEY
 LP Line printer
 O/P output
 I/P input

FIGURE 1 - A DIAGRAMMATIC REPRESENTATION OF BCRS

A. When updating files

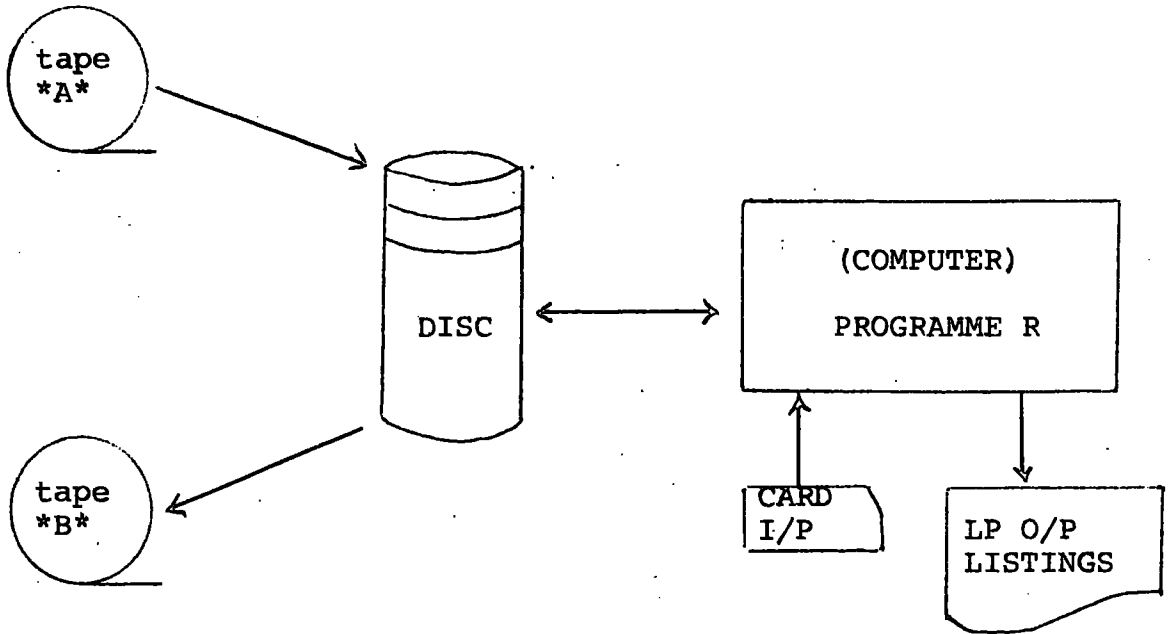

B. When not updating files

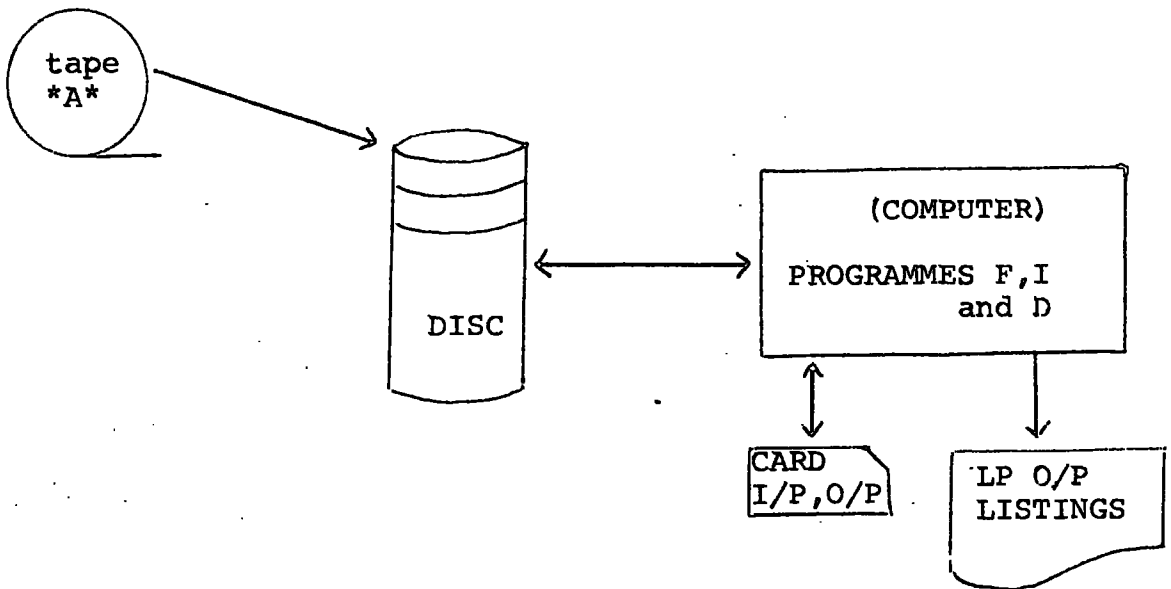

| KEY | |
|-----|--------------|
| LP | line printer |
| O/P | output |
| I/P | input |

FIGURE 2. BCBS TAPE PROCEDURES

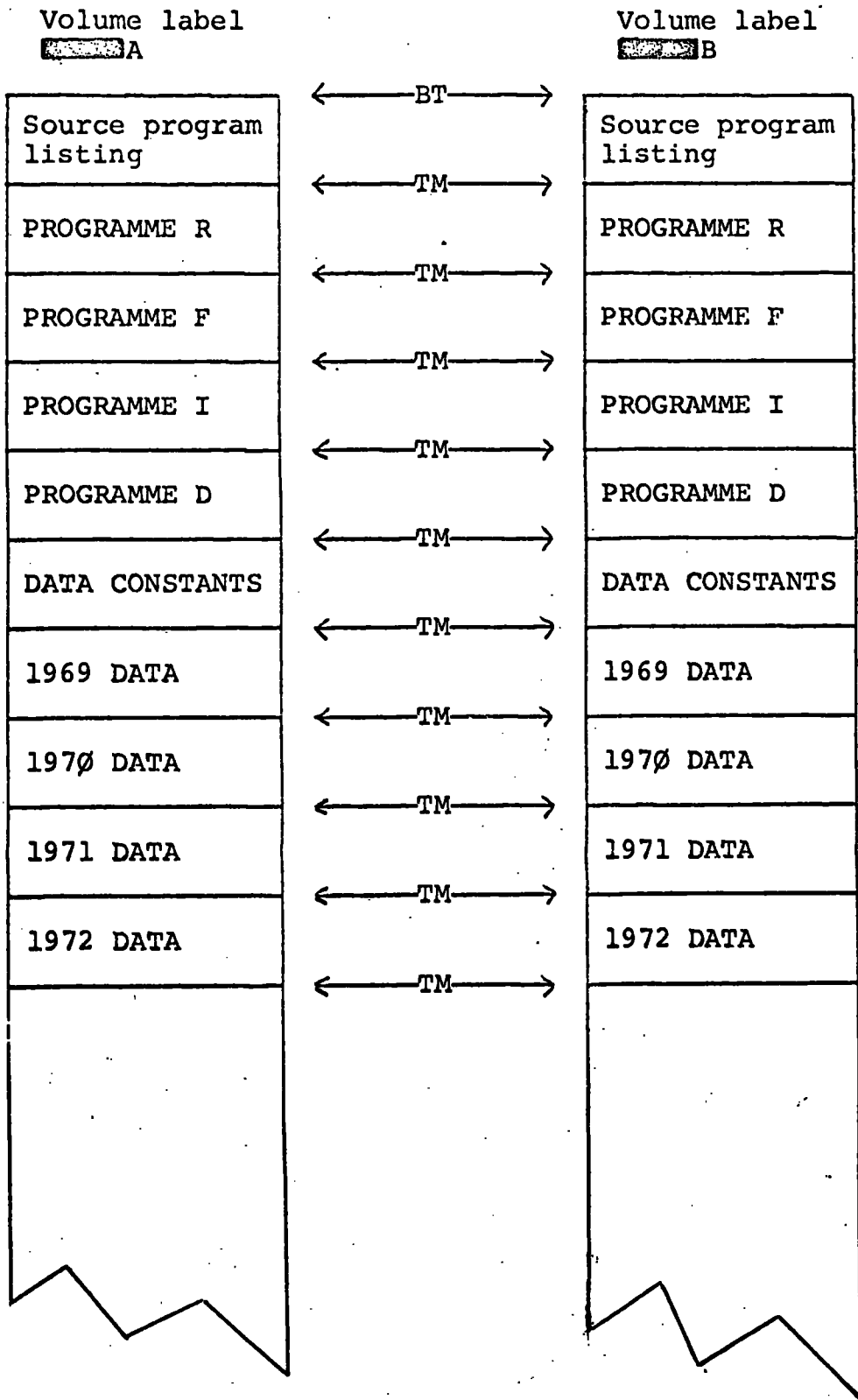

FIGURE 3. TAPE FORMATS

KEY
 BT beginning of tape
 TM tapemark

3. INFORMATION RECORDED

The information recorded in BCRS consists of items taken from the Bede College Personal Record Card and the results of several Intelligence Tests undertaken by the students at the College.

Much of the information at present recorded was not available for the years prior to 1972. Such items have been marked '*' in the following listing. Items marked '+' signify that the codes recorded are different prior to 1972. The codes adopted are listed in GENERAL CODES, Appendix 5.

| 3.1 RECORD CARD | (No. of characters) |
|---|---------------------|
| Name | 40 |
| D.E.S. No. | 8 |
| 1. GENERAL AND DEMOGRAPHIC | |
| Sex | 1 |
| Title | 2 |
| *Original Surname if different | 17 |
| Date of Birth | 6 |
| *Date of Birth Certification | 1 |
| Marital Status | 1 |
| *Classification of Area: Region | 1 |
| +Classification of Area: Settlement | 1 |
| Position in Family | 4 |
| +Classification of Parent/Guardian Occ. | 1 |
| +Student Occupation | 1 |
| Over 25 Occupation | 1 |
| +Religion | 1 |
| Confirmed (or equivalent) | |
| Year Confirmed | 2 |
| *Authority or Country | 19 |
| *Authority or Country Number | 1 |
| Teachers' Training: From date | 6 |
| To date | 6 |
| 2. PREVIOUS EDUCATION | |
| No. of School Attended | 2 |
| School Code | 1 |
| School Attendance Dates: From (year) | 2 |
| To (year) | 2 |
| No. of Qualifications recorded | 2 |
| Qualifications: | |
| Year of Examination | 2 |
| Type of Examination | 3 |
| Subject Code | 3 |
| Grade | 1 |
| Pass/Fail | 1 |
| *University/College attended: | |
| For degree study | 2x21 |
| Full/Part time | 2x 1 |
| From date | 2x 6 |
| To date | 2x 6 |

(No. of characters)

| | |
|---------------------------------------|------|
| *University/Other Body: | |
| Degree Awarding Body | 2x21 |
| Title of Degree | 2x 3 |
| Hons/Pass | 2x 1 |
| Class/Division | 2x 3 |
| Main Subjects | 2x36 |
| Date of Award | 2x 6 |
| *Excepted by A.T.O. from Examination | 1 |
| *Diploma in Art and Design | 30 |
| *Diploma in Art and Design Confirmed | 1 |
| *National Diploma in Design Confirmed | 1 |
| *Other Art Qualifications | 2x30 |
| *Other Art Qualification Codes | 2x 4 |

2. DETAILS OF COURSE

| | |
|----------------------------------|---|
| Length of Course | 1 |
| Main Subject Code | 3 |
| 2nd Prov. Subject Code | 3 |
| *Details of Course: | |
| Year of Student's Course | 1 |
| Repetition | 1 |
| Date Student's Year begins | 4 |
| Expected End of Student's Course | 4 |
| A.T.O. Approved | 1 |
| *Scope of Training: | |
| 5 to 7 | 1 |
| 7 to 9 | 1 |
| 9 to 11 | 1 |
| 11 to 13 | 1 |
| Over 13 | 1 |
| Mentally Handicapped | 1 |
| Not yet decided | 1 |
| *No. of Subjects: | |
| Main Subject | 1 |
| Subsidiary Subject | 1 |
| Undecided | 1 |
| Subject Codes: | |
| Main Subject | 3 |
| 2nd Prov. Subject | 3 |
| *Postgraduate Courses | 1 |
| *B.Ed. Course | 1 |

4. COURSE RESULTS

Since the structure of the Courses offered by the College is continually changing, the course results are not recorded in any fixed format. Each field appearing in the section COURSE RESULTS is given a field label (see COURSE RESULTS, Appendix 1). These labels are recorded, and the information to which they refer is recorded in the ANNUAL PROGRESS VECTOR.

5. FINAL RESULTS

| | |
|-----------------------|---|
| Teachers' Certificate | 1 |
| Wing Science | 1 |
| B.Ed. | 1 |

6. ADDITIONAL INFORMATION

| | |
|-----------------------|---|
| Date of Withdrawal | 6 |
| Reason for Withdrawal | 1 |
| Subsequent Career | 1 |

3.2 INTELLIGENCE TEST SCORES

1. RAW SCORES

A Study of Values
The Dogmatism Scale
A.H.4
P.F.16

2. STEN SCORES

The Sten scores as calculated from the
P.F.16 scores

3.3 IMPLEMENTATION RESTRICTIONS

The following implementation restrictions have been imposed to reduce storage requirements:

1. School Type. The maximum number of School Codes and School Attendance Dates recorded in any one record is 10.
2. Qualifications. The maximum number of qualifications recorded in any one record is 30.
3. Annual Progress Vector. In any one record the maximum size of the Annual Progress Vector is 802 characters and the maximum number of Field Labels allowed is 100 (A1 to A100).
4. Details of Course. In any one record a maximum of 4 complete entries may be recorded in this section. The first entry will contain the Details of Course on admission. New entries arise when the student changes course or changes subjects and the last entry will be continually overwritten every time this limit is exceeded.

3.4 DEFAULT FIELD SETTINGS

Students who are over 25 on admission and who have no entry in the section marked Over 25 Occupation will be recorded as 'Other', i.e. code 0.

Any entry recorded in this section by students who are under 25 on admission will be reset to blank.

3.5 DATA CHECKING PROCEDURES

When recording the data in a student's record, BCRS will check several of the data items to ensure that the value of the item recorded is 'reasonable'.

If the value is not reasonable an error message will be printed and the user must correct as many as possible of the item values in error. This can be done by using programme R option 9, or by re-establishing the file from data cards once the errors have been corrected.

The items checked and the corresponding error messages are given below:

RECORD DATA

- AGE : (message: D.E.S. NO. AGE CHECK, RECORDED AS xx)
The age recorded xx is less than 17 or greater than 60.
- SEX : (message: D.E.S. NO. ERROR RETURNED SEX)
The Sex code recorded is neither 'M' nor 'F'.
- MARITAL STATUS : (message: D.E.S. NO. ERROR RETURNED MARITAL STATUS)
The code recorded for Marital Status lies outside the range 1 to 3 inclusive.
- RELIGION : (message: D.E.S. NO. ERROR RETURNED RELIGION)
The code recorded for Religion lies outside the range 1 to 5 inclusive, or 1 to 6 inclusive for those admitted prior to 1972.
- SETTLEMENT : (message: D.E.S. NO. ERROR RETURNED SETTLEMENT)
The code recorded for Settlement lies outside the range 1 to 6 inclusive, or 1 to 4 inclusive for those admitted prior to 1972.
- REGION : (message: D.E.S. NO. ERROR RETURNED REGION)
The code recorded for Geographical Region lies outside the range A to K inclusive.
- PARENT/GUARDIAN and STUDENT OCCUPATION : (message: D.E.S. NO. ERROR RETURNED PARENT/GUARDIAN OCCUPATION)
(message: D.E.S. NO. ERROR RETURNED STUDENT OCCUPATION)
The code recorded for Parent/Guardian Occupation or for Student Occupation lies outside the range 1 to 5 inclusive or 1 to 6 inclusive for those admitted prior to 1972. In the case of the Student Occupation a code of ' ' (blank) is acceptable.

OVER 25 OCCUPATION : (message: D.E.S. NO. ERROR RETURNED OVER 25 OCCUPATION)
 The code recorded for the Over 25 Occupation lies outside the range 0 to 9 inclusive, but a code of ' ' (blank) is acceptable.

FAMILY POSITION : (message: D.E.S. NO. ERROR RETURNED FAMILY POSITION)
 The code recorded for Family Position records the student as the 'n'th child in a family of 'm' where 'n' is greater than 'm'.

START DATES : (message: D.E.S. NO. ERROR RETURNED START DATE CHECK)
 The date recorded for Teacher Training (From) does not correspond to the date given in Details of Course (Date student's year begins).

AUTHORITY/COUNTRY NO. : (message: D.E.S. NO. ERROR RETURNED AUTHORITY/COUNTRY NUMBER)
 The code recorded for the Authority/Country Number (Type of Student) lies outside the range 1 to 5 inclusive.

INTELLIGENCE TEST DATA

Each Intelligence Test score is checked to ensure that it lies within the acceptable range for that test. If it falls outside that range one of the following error messages will be printed:

D.E.S. NO. ERROR RETURNED FOR VALUES SCORE k
 D.E.S. NO. ERROR RETURNED FOR D.SCALE SCORE
 D.E.S. NO. ERROR RETURNED FOR A.H.4 SCORE k
 D.E.S. NO. ERROR RETURNED FOR P.F.16 SCORE k

The STEN SCORES will only be calculated if ALL the P.F.16 scores lie within the acceptable ranges.

If an item in error cannot be corrected the checking procedures in the subsequent options which refer to this item will raise either a CLASS E or a CLASS F error/warning, see BCRS Error/Warning Messages, Appendix 4.

4. PROGRAMME OPTIONS

This section outlines the Programme Options provided by the programmes R, F, I and D. The Options may be summarised as follows:

PROGRAMME R

- OPTION 1 Admission of records to BCRS.
- 2 Input of Intelligence Test records.
- 3 Annual Record Update. Transaction file established for those leaving.
- 4 Set Withdrawal Code. Transaction file established for withdrawals
- 5 Admissions listing for D.E.S.
- 6 File and Record Listings.
- 7 Late admissions: i.e. transfers from other Training establishments. Transaction file established for late admissions.
- 8 Change of course/subject. Transaction file established for a change of course/subject.
- 9 Record field alterations. Specified record print routine.
- 10 Transaction file established for Admissions.

PROGRAMME F

- OPTION 1 General Information Frequency Tables.
- 2 Interrogation Routines with Optional Frequency Tables.

PROGRAMME I

- OPTION 1 Intelligence Test totals, means and standard deviations.
- 2 Intelligence Test Frequency Tables.
- 3 Intelligence Test file and record listings.
- 4 Interrogation routines.

PROGRAMME D

NO OPTIONS are available with programme D. The required Transactions are established in the Transaction File by Options 3, 4, 7, 8 and 10 of programme R.

BCRS allows the user to select any number of options and to process more than one data file during the execution of programmes R, F or I. To do this an OPTION PARAMETER CARD is required, the exact format of which is given in a later section. This card notifies BCRS which file(s) to use, which option(s) are required, and provides, where required, specific PARAMETERS for that option.

4.1 PROGRAMME OPTIONS PROGRAMME R

The options provided by programme R provide facilities for establishing and updating the data files, and for preparing the Transaction File for programme D which produces the Data Interchange card output for D.E.S. In many cases these options require data cards on which will be punched either records to be established, or amendments and updates to be added to records already in existence. These cards should always be arranged in ascending order of D.E.S. No. since this will provide quicker access time when searching the file(s) for the specified record. The end of such data decks should be terminated by a card having '*****' punched in columns 1 to 8.

OPTION 1: Admission of records to BCRS

This option is used to establish a file of student records in the Data Base.

On admission a student's record which comprises information from sections General and Demographic, Previous Education and Course Details, should be punched on cards in the format given by RECORD ADMISSIONS CARD FORMAT, Appendix 2.

Option 1 will now transfer this information to BCRS data files and in so doing establish a record for each student. All records must be processed by this option for until this has been done they will not exist in BCRS and any reference to such a record will result in a CLASS C error/warning message.

Due to an Implementation Restriction (see page 12) students who are recorded as having more than 10 school attendance codes or more than 30 qualifications will raise a CLASS Q error/warning message. Only the first 10 school attendances and the first 30 qualifications will be recorded, and in such cases, particularly with the qualifications, the user should ensure that the most important qualifications are recorded first.

There are no parameters required by this option.

OPTION 2: Input of Intelligence Test records

This option is responsible for the input of the Intelligence Test results and their association to their corresponding records in BCRS.

The Intelligence Test information should be punched on cards in the format given by INTELLIGENCE TESTS CARD FORMAT, Appendix 2. Only records which have a result for all the tests should be coded. These results will now be recorded in their corresponding records, and the STEN scores are also calculated and recorded for the P.F.16 scores.

All Intelligence Test scores must be processed by this option. If this is not done then BCRS will record that the student(s) have no Intelligence Test information which will raise a CLASS L error/warning message in subsequent options.

If a D.E.S. No. given with an Intelligence Test record cannot be associated with any D.E.S. No. in the specified file a CLASS C error/warning message is given.

The parameters required for this option are YT and NTT.

OPTION 3: Annual Record Update
Transaction File established for those leaving

This option is used for the Annual Updating of the record and for the preparation of the Transaction File (for programme D) for those who have completed their courses and are leaving.

The information to be added to the records should be prepared on cards observing the general formatting rules given in RECORD UPDATING CARD FORMAT, Appendix 2.

If a D.E.S. No. given with a set of information is not found in the specified file a CLASS C error/warning message is given.

Due to an Implementation Restriction (see page 12) the maximum size of the Annual Progress vector is 802 characters and if this limit is exceeded a CLASS P error/warning message will be given.

Students are recorded as leaving when the year of update is equal to the course length. The additional information for students who are leaving should be punched on cards in the format given by Rule 8, RECORD UPDATING CARD FORMAT, Appendix 2. If the parameter DES is specified the Transaction File for programme D will be prepared for these students.

If an update is attempted with a year of update greater than the course length a CLASS H error/warning message is given. With students progressing to a fourth year the length of course will be altered appropriately; and a CLASS R error/warning message given.

The parameters required for this option are VP and DES.

OPTION 4: Set Withdrawal Code
Transaction File established for those withdrawing

This option is used to record that a student has withdrawn from the College, and for the preparation of the Transaction File for such an event.

When a student withdraws from the College, BCRS will record the reason for withdrawal and the date of withdrawal. Codes for the reasons for withdrawal are given in WITHDRAWAL CODES, Appendix 5, and the format in which the information should be punched is given by WITHDRAWALS CARD FORMAT, Appendix 2.

If the D.E.S. No. given is not found in the specified file a CLASS C error/warning message will be given. If the parameter DES is specified the Transaction File for programme D will be prepared.

The parameters required for this option are VP and DES.

OPTION 5: Admissions listing for D.E.S.

This option is used to provide the listing of admissions required by the Teachers Training Section at D.E.S.

The listing produced by this option includes only students whose D.E.S. No. (year) corresponds to the year in which their course started. Students who have been admitted by D.E.S. in previous years will raise a CLASS N error/warning message.

The listing gives D.E.S. No., Name, Type of Student, Date of Birth, From and To dates, and Degree Titles and Awarding Bodies where applicable. This list is in alphabetical order within Type of Student.

If the length of course is in error, a CLASS D error/warning message is given and the course length assumed to be 3 years.

There are no parameters required for this option.

OPTION 6: File and Record Listings

This option is used to produce listings of students included in specified file(s).

The listings produced by this option depend on the value of the parameter PI. For details see THE PARAMETER PI IN PROGRAMME R, page 27.

The parameter PI is required for this option.

**OPTION 7: Late admissions, i.e. transfers from other Training establishments
Transaction file established for late admissions**

This option is used to establish a record in a specified file for Late Admissions to the College, and for preparing the Transaction File for programme D.

This option allows the user to establish a record in a specified BCRS data file for students who are admitted to College after term has started. If the parameter DES is specified a re-admission transaction is established in the Transaction File for programme D, since in such cases the student has to be admitted to BCRS but re-admitted for D.E.S. purposes.

The student's record should be punched on cards in the format given by RECORD ADMISSIONS CARD FORMAT, Appendix 2. The record(s) will be added to the end of those already existing in the specified file.

The parameter DES is required for this option.

**OPTION 8: Change of course/subject
Transaction File established for changes of course**

This option is used to record that a student has changed course or changed subject and to provide the necessary transaction in the Transaction File for programme D.

Throughout the year several students may change their courses or their subjects, thus providing another line in the section DETAILS OF COURSE. This option is used to record this change, and the information should be punched on cards in the format given by COURSE/SUBJECT CHANGES CARD FORMAT, Appendix 2. Provided there is sufficient space in this section, BCRS will record these details, but if the section is already full the previous entry will be overwritten, see Implementation Restrictions, page 12.

If a D.E.S. No. given with this latest entry to the course details cannot be found in the specified file a CLASS C error/warning message is given.

The parameters required for this option are VP and DES.

OPTION 9: Record Field alterations
Specified record print routine

This option can be used to alter a specified field within a given record, and to provide a full print of any specified record.

To use this option the user should be familiar with the PL/1 GET DATA instruction, see IBM PL/1 Language Reference Manual C28-8201, page 106^[46]. This option is extremely useful for making small alterations to specified records, for example if a student were to marry during his course then this option allows the field of Marital Status to be updated in that student's record. To make such an alteration we have to know the Identifier (Fully Qualified) of the field we propose to alter. These are listed below for the main record fields:

| <u>Identifier (Fully Qualified)</u> | <u>Record Field</u> |
|-------------------------------------|--------------------------------|
| RECORD.NAME | Name |
| RECORD.DESNO | D.E.S. No. |
| RECORD.GENERAL.SEX | Sex |
| RECORD.GENERAL.REL | Religion |
| RECORD.GENERAL.SET | Settlement code |
| RECORD.GENERAL.REG | Geographical region |
| RECORD.GENERAL.MART | Marital Status |
| RECORD.GENERAL.POCC | Parent/Guardian occupation |
| RECORD.GENERAL.SOCC | Student occupation |
| RECORD.GENERAL.OV25 | Occupation if over 25 |
| RECORD.GENERAL.CONF | Confirmation |
| RECORD.GENERAL.YC | Year confirmed |
| RECORD.GENERAL.TITLE | Title |
| RECORD.GENERAL.FPOS | Position in family |
| RECORD.GENERAL.DOB | Date of Birth |
| RECORD.GENERAL.DOBC | Date of Birth certificate |
| RECORD.GENERAL.AUTH | Authority/Country |
| RECORD.GENERAL.AUTHNO | Authority/Country number |
| RECORD.EDUCATION.SCHNO | No. of schools recorded |
| RECORD.EDUCATION.QUALNO | No. of qualifications recorded |
| RECORD.COURSE.LEN | Course length |
| RECORD.FINALS.TC | Teacher's Certificate |
| RECORD.FINALS.WS | Wing Science |
| RECORD.FINALS.BE | B.Ed. |
| RECORD.FINALS.SUBCAR | Subsequent career |

The general form for making an alteration is:

identifier(fully qualified)='new value'

and to take an example let us alter the Marital Status of a student whose D.E.S. No. is 'D.E.S. No.', from single i.e. code 1, to married i.e. code 2. We would prepare the following data card:

```
D.E.S.No RECORD.GENERAL.MART='2' ;
↑       ↑                   ↑
col(1)  space                space
```

Note that the character ';' is required as a terminator, terminating the list of alterations made to any one D.E.S. No.

The use of this option to provide a full print of a specified record is described in THE PARAMETER VP IN PROGRAMME R, page 28.

If the D.E.S. No. given cannot be found in the specified file a CLASS C error/warning message is given.

The parameter VP is required for this option.

OPTION 10: Transaction File established for Admissions

This option is used to prepare the Transaction File for programme D for student admissions.

Students in the specified file whose D.E.S. No. (year) does not correspond to their year of entry to the College are not included and will raise a CLASS N error/warning message.

The parameter DES is required for this option.

4.2 PROGRAMME OPTIONS PROGRAMME F

The frequency counts produced by the options in programme F will be preceded by a list of the D.E.S. Nos. of those students included in the calculations. If the number of students included exceeds 1000 this list is suppressed. The parameters WRL and WCR are required by all options in programme F.

OPTION 1: General Information Frequency Tables

This option is used to produce frequency tables of the following items:

- Age, over 25 and under 25 on admission
- Sex
- Marital Status
- Geographical Region
- Settlement Code
- Parent/Guardian Occupation
- Student Occupation
- Occupation if over 25 on admission
- Religion
- School Type
- Position in Family

If the recorded item(s) fall outside the permissible range a CLASS E error/warning message is given and the item will be ignored from the respective table. This message will also be given for any student whose Position in Family is greater than the 10th child of 10.

The parameters required for this option are WRL and WCR.

OPTION 2: Interrogation Routines with Optional Frequency Tables

This option is used to provide a frequency count of the students who meet the requirements of a user REQUEST.

By the use of user REQUESTS a wide range of subsets of students can be selected from the specified file. The REQUESTS should be prepared in the form described by THE PARAMETER REQUEST IN PROGRAMMES F AND I, page 32. If the parameter FREQ is specified the Frequency tables provided by Option 1 will be produced for the subset of students included in the REQUEST.

The parameters required for this option are WRL, WCR, REQUEST and FREQ.

4.3 PROGRAMME OPTIONS PROGRAMME I

As in programme F, if the number of students included exceeds 1000 the list of D.E.S. Nos. is suppressed. The parameters YT, WRL and WCR are required by all options in programme I.

OPTION 1: Intelligence Test totals, means and standard deviations

This option is used to provide totals, means and standard deviations for the Intelligence Tests.

Students who have no associated Intelligence Test scores will raise a CLASS L error/warning message.

The parameters required for this option are YT, WRL and WCR.

OPTION 2: Intelligence Test Frequency tables

This option produces frequency tables on the Intelligence Test scores and the STEN scores.

A CLASS F error/warning message will be given if the score recorded for any test falls outside the permissible range, and the score will be ignored in the frequency table for that test.

The parameters required for this option are YT, WRL and WCR.

OPTION 3: Intelligence Test file and record listings

This option provides two print routines for the Intelligence Test scores.

The form of the print routines provided by this option are described in THE PARAMETER PI IN PROGRAMME I, page 27.

The parameters required for this option are YT, PI, WRL and WCR.

OPTION 4: Interrogation routines

This option allows the user to select a subset of the population of a specified file by giving a REQUEST in the same manner as option 2 programme F.

REQUESTS are described in THE PARAMETER REQUEST IN PROGRAMMES F AND I, page 32, and the output produced includes totals, means, standard deviations and frequency tables as provided by options 1 and 2.

The parameters required for this option are YT, WRL, WCR and REQUEST.

4.4 PROGRAMME TRANSACTIONS PROGRAMME D

Programme D is responsible for the punched card output for the Data Interchange System.

When card output is required the parameter DES should be specified in the relevant option in programme R. This option will establish the Transaction File which records the D.E.S. Nos. and the required transactions. Programme D uses this information as data and produces card output in the format specified by that transaction.

The transactions available are:

- transaction 01 Admissions
 - 11 Change of course/subject, including the extension to the B.Ed. course
 - 12 Withdrawals/End of course
 - 15 Re-admission, i.e. transfer from other Training Establishments

If the user fails to specify the parameter DES, programme D will print a CLASS B error/warning message and terminate. If a D.E.S. No. given in the Transaction File cannot be found in the specified file, a CLASS I error/warning will be printed and the transaction ignored. Likewise if the transaction code is in error a CLASS J error/warning will be given.

TRANSACTION 01: Admissions

Card output will be produced for the required students in the format given in CARD OUTPUT ADMISSIONS, Appendix 3.

If the Authority/Country recorded in the record cannot be matched with any appearing in the CONSTANTS file or if an A'level code cannot be matched, a CLASS K error/warning message will be given. The recorded item should be checked against those appearing in the constants file.

TRANSACTION 11: Change of Course/Subject

Transaction 11 is used by D.E.S. to record that a student has changed his course/subject.

The format of the cards produced is given in CARD OUTPUT CHANGE OF COURSE/SUBJECT, Appendix 3.

TRANSACTION 12: Withdrawals/End of Course

This transaction is used by D.E.S. to record that a student has withdrawn from the College or has completed his course and left. The card output produced is described in CARD OUTPUT WITHDRAWALS, and CARD OUTPUT END OF COURSE, Appendix 3.

TRANSACTION 15: Re-admission

This transaction is used by D.E.S. to record that a student is to be re-admitted. The format of the output is given in CARD OUTPUT RE-ADMISSION, Appendix 3.

After each transaction has been completed a CLASS 0 error/warning message is printed. This monitors the transactions as they are executed and enables the user to locate subsequent errors should they arise.

THE OPTION PARAMETER CARD

The OPTION PARAMETER CARD is vital to BCRS. By means of this card the user informs BCRS of the option(s) he requires and the data file(s) he wishes to use. For every option an OPTION PARAMETER CARD must be supplied containing the following information:

1. The name of the data file to be used with this option.
2. The name of the file containing data constants.
3. The year of the data file.
4. The number of the option required.
5. Special parameters for this option if required.
6. A semicolon preceded by a space.

The name of the data file and that of the file containing data constants must not be greater than 8 characters, and must correspond to the PL/1 file names associated with the MTS file names on the FRUN card. This association informs BCRS of the data file and the data constants file to be used in this option.

The year of the data file is only used for titles and where several actual data files of different years have been combined this field may be replaced by any four characters.

The number of the required option is checked against those available for the programme being run, and if found to be in error a CLASS A error/warning message is given.

Each option may or may not require certain parameters. The TABLE OF PARAMETERS is given on page 25, and the remaining part of this section describes in detail the functions of these parameters. If a parameter is not given when it should have been, a default value is given and execution continues. The TABLE OF PARAMETER DEFAULT VALUES is given on page 41. The requested option, year of data file and the parameter specified are printed as a heading to the output for that option.

The OPTION PARAMETER CARD must always be terminated by a ';' preceded by a space. If this is not supplied the computer will print an error message and terminate execution at that point, thus ignoring this and the subsequent options the user had requested.

The format of the OPTION PARAMETER CARD is as follows:

| Field | Columns | |
|-------|---------|--|
| 1 | 1- 8 | The name of the data file |
| 2 | 10-17 | The name of the data constants file |
| 3 | 19-22 | The year of the data file |
| 4 | 24-25 | The requested option |
| 5 | 27+ | Option parameter if any, terminated by a semicolon preceded by a space |

N.B. As no options are available with programme D, field 4 should be omitted. In programme I the data constants file is not required and field 2 can be omitted.

TABLE OF PARAMETERS

The following table lists the parameters required for each option. These parameters must be specified on the OPTION PARAMETER CARD.

| PROGRAMME | OPTION | PARAMETER | | | | | | | | |
|-----------|--------|-----------|-----|-----|--|----|-----|-----|------|---------|
| R | 1 | | | | | | | | | |
| | 2 | YT | NTT | | | | | | | |
| | 3 | | | DES | | | VP | | | |
| | 4 | | | DES | | | VP | | | |
| | 5 | | | | | | | | | |
| | 6 | | | | | PI | | | | |
| | 7 | | | DES | | | | | | |
| | 8 | | | DES | | | VP | | | |
| | 9 | | | | | | VP | | | |
| | 10 | | | DES | | | | | | |
| F | 1 | | | | | | WRL | WCR | | |
| | 2 | | | | | | WRL | WCR | FREQ | REQUEST |
| I | 1 | YT | | | | | WRL | WCR | | |
| | 2 | YT | | | | | WRL | WCR | | |
| | 3 | YT | | | | PI | WRL | WCR | | |
| | 4 | YT | | | | | WRL | WCR | | REQUEST |
| D | | | | DES | | | | | | |

A parameter is specified in the format PARAMETER='PARAMETER VALUE' and where more than one parameter is required they should be separated by a space.

The lengths of the PARAMETER VALUES are as follows:

| | |
|----------------------------|-------------------------------------|
| YT, NTT, VP, PI, WCR, FREQ | 1 character each |
| WRL | 3 characters |
| REQUEST | varying up to max of 400 characters |
| DES | 8 characters |

THE PARAMETER YT IN PROGRAMMES R AND I

The Intelligence Tests are taken by all students when they are admitted to the College. In subsequent years it may be possible for the students to take the same set of tests before leaving the College, thus providing what is known as Longitudinal Data.

As BCRS provides storage for a second set of results, the user must specify which set is to be considered. To do this the parameter YT (Year of Test) is used.

If the parameter YT='F' is specified, BCRS will use the set of Intelligence Test results corresponding to the student's First year at College.

If the parameter YT='L' is specified, those results corresponding to the student's Last year at College will be used.

THE PARAMETER NTT IN PROGRAMME R

When the Intelligence Test records are being associated with their corresponding records in BCRS, the STEN SCORES are calculated and recorded for the P.F.16 tests. BCRS provides two TABLES OF NORMS FOR COLLEGE STUDENTS and either may be used to calculate the Stens. The parameter NTT is used to inform BCRS which table to use.

If the parameter NTT='1' is specified, BCRS will provide the NORM table given on page 42.

If the parameter NTT='2' is specified, the NORM table given on page 43 is provided.

[N.B. For data files prior to 1973, NTT='1' was used.]

THE PARAMETER PI IN PROGRAMME R

The parameter PI (Print Indicator) is used to inform BCRS of the print option required. The following print options are available:

PI='1' This will provide a full print of every record in the specified file. The records will be printed in the order in which they appear in the file. Each record will provide one page of output, and if this print option is used the user should ensure that a suitable output page limit is specified.

PI='2' A listing will be provided of the D.E.S. Nos. of all students in the specified file. The D.E.S. Nos. will be printed in the order in which the records appear in the file. An '*' will flag those students who are recorded as having withdrawn from the College, and a '+' those who have completed their courses and left.

PI='3' This print option provides a listing in alphabetical order of the names of all students in the specified file. The D.E.S. Nos., Dates of Birth and From/To dates are also printed.

PI='4' This print option lists the students in the specified file alphabetically within Type of student within Main Subject code. Students who have no Main Subject code are listed separately. If the Type of student is recorded in error a CLASS D error/warning message is given. The corresponding D.E.S. Nos. are also printed and students who have withdrawn or who have completed their courses and left are not included.

THE PARAMETER PI IN PROGRAMME I

In programme I the parameter PI (Print Indicator) is again used to inform BCRS of the print option required. Two print options are provided and in each case the students included will be those who have Intelligence Test data and who belong to the subset(s) selected by the WRL and WCR parameters. The available print options are:

PI='1' This print option provides a full print of the recorded Intelligence Test records and the corresponding Sten scores for the P.F.16 tests. The records when selected are printed in the order in which they appear in the file. The corresponding D.E.S. Nos. are also printed.

PI='2' This print option lists only the D.E.S. Nos. of those students included in the selected subset(s). The D.E.S. Nos. are listed in the order in which they appear in the file.

THE PARAMETER VP IN PROGRAMME R

The parameter VP (Verification Print) is used if the user requires verification of a particular update. In such cases a print will be given of the whole record or merely that part of the record which was updated.

The parameter has two values:

VP='1' i.e. a verification print is required, and
VP='Ø' i.e. no verification print is required

If the parameter VP='1' is specified with Option 3, the verification print will consist of that part of the record just added (i.e. the part corresponding to the year of update).

If the parameter VP='1' is specified with Option 4, the verification print will provide the date of withdrawal and the reason for withdrawal.

If the parameter VP='1' is specified with Option 8, the verification print will comprise the new course details.

If the parameter VP='1' is specified with Option 9, the verification print will provide a full print of that record. Since Option 9 allows us to alter a specified field within a specified record and if VP='1' is specified, obtain a verification print of the whole record, then by specifying the record but not specifying any particular field we can obtain a full verification print of that record. To do this the D.E.S. Nos. of those records to be printed should be punched in columns 1 to 8 of the card followed by a ';' in column 10, thus providing the data cards for Option 9.

THE PARAMETER FREQ IN PROGRAMME F

The parameter FREQ may be specified if the user wishes to produce a set of Frequency tables for a given REQUEST. The tables provided will comprise the same set as those produced for programme F option 1.

If the parameter FREQ='Ø' is specified, a list will be provided of the D.E.S. Nos. of those students accepted by the REQUEST.

If the parameter FREQ='1' is specified, the list given above will be accompanied by the set of Frequency tables for those students.

THE PARAMETER DES IN PROGRAMMES R AND D

In programme R this parameter is used to inform BCRS that Data Interchange card output is required, and that the 'PARAMETER VALUE' is the name of the Transaction file on which the D.E.S. Nos. and transaction codes are to be written.

If no Data Interchange card output is required, this parameter should NOT be specified.

In programme D this parameter is used to inform BCRS of the name of the file which contains the D.E.S. Nos. and transaction codes for the Data Interchange system.

In both cases the file name must not be more than 8 characters and must correspond to the name of the PL/1 file associated with the MTS file name on the ERUN card.

THE PARAMETERS WRL AND WCR IN PROGRAMMES F AND I

Let us consider all the admissions to the College in any one year as a SET of students. During the year several of the students who were admitted may withdraw. This group we will consider as a SUBSET of the original set. Similarly, certain students will complete their courses and leave the College before others. This group forms yet another SUBSET within the original set. Thus while students admitted in any given year are at the College, all the students of that year belong to one of three subsets:

- 1.1 Those that have withdrawn
- 1.2 Those that are still at the College
- 1.3 Those that have completed their courses and left

In programmes F and I the parameter WRL (Withdrawn, Remaining, Left) allows us to consider any of the three subsets given above, or any combination of them. If we wish to include a particular subset we set the corresponding WRL field to 1. If we wish to exclude a subset we set the field to \emptyset .

For example, WRL='1 $\emptyset\emptyset$ ' would mean that we wish to include the subset of those who have withdrawn, and exclude those who are still at the College and those that have left.

WRL=' \emptyset 1 \emptyset ' would mean that we wish to include only those who are still at the College and exclude the other two subsets.

WRL=' $\emptyset\emptyset$ 1' include subset 1.3, exclude 1.1 and 1.2

WRL='1 \emptyset 1' include subsets 1.1 and 1.3, exclude 1.2

WRL='11 \emptyset ' include subsets 1.1 and 1.2, exclude 1.3

WRL=' \emptyset 11' include subsets 1.2 and 1.3, exclude 1.1

WRL='111' include subsets 1.1, 1.2 and 1.3

WRL=' $\emptyset\emptyset\emptyset$ ' exclude subsets 1.1, 1.2 and 1.3

Excluding the case WRL=' $\emptyset\emptyset\emptyset$ ' there are seven groups we may consider. Further subdivision is possible and programmes F and I allow us to subdivide subset 1.1 by using the parameter WCR (Withdrawn Code Required). If subset 1.1 is included by the WRL parameter, then by setting WCR equal to an acceptable value corresponding to one of the Withdrawal Codes (see GENERAL CODES, Appendix 5) we would include only those who have withdrawn for the specified WCR reason.

For example, WCR='1' would mean that we wish to include those who have withdrawn for reason 1 only (i.e. due to unsatisfactory progress)

Likewise, WCR='2' transfer to another training establishment

WCR='3' health reasons

WCR='4' death

WCR='5' intercalation

WCR='9' any other reason

A further item has been included, namely:

WCR='*' which means that we wish to include those who have withdrawn for any reason.

In some cases it may be interesting to know which students in a set fall into the subset(s) not selected by the WRL parameter. To include this we replace fields appearing as \emptyset in the WRL parameter with 2, the effect being that error/warning CLASS G messages will be printed for the subset(s) of students not included.

It should be noted however that in time subset 1.2 will be absorbed into subsets 1.1 and 1.3, a process completed when the last students admitted in a given year withdraw or leave the College. Thereafter our subsets may be redefined as follows:

- 2.1 Those that withdrew
- 2.2 An empty or null subset
- 2.3 Those that completed their courses and left

Note that the default for the parameter WRL is the null set WRL=' $\emptyset\emptyset$ '.

THE PARAMETER REQUEST IN PROGRAMMES F AND I

In programmes F (option 2) and I (option 4), the parameter REQUEST allows the user to subdivide the subsets included by WRL and WCR in a very powerful way. On receiving a REQUEST which takes the form of a coded question the computer will search the record field(s) specified by the REQUEST. If the REQUEST is true, this record will be accepted; if not, then the record is rejected.

Let us consider three examples:

1. "How many Roman Catholic students are over 21 and under 25?"
2. "How many students under 21 are married?"
3. Select as a subset "those students who have more than 2 A'level passes and an O'level pass in English Language or Mathematics"

In each case we are selecting a certain subset of students. Selection may however involve one or more ITEMS. For example, in the first REQUEST the ITEMS involved are Religion and Age, while in the second the ITEMS are Marital Status and Age.

Considering the first example in detail we have to make three tests:

- 1.1 is the student Roman Catholic?
- 1.2 is the student over 21?
- 1.3 is the student under 25?

Each of these tests forms what we call a SIMPLE REQUEST, which we shall define as follows:

<SIMPLE REQUEST>=
<SPACE><ITEM NO.><RELATIONAL OPERATOR><ITEM VALUE>
<SPACE>

where <ITEM NO.> is any acceptable ITEM NO. corresponding to the field required

<ITEM VALUE> is any acceptable value for the ITEM NO.

<RELATIONAL OPERATOR> may be = (equal to)
≠ (not equal to)
> (greater than)
≥ (not greater than)
< (less than)
≤ (not less than)

With reference to the table of ITEM NUMBERS, ITEMS and ITEM VALUES (see page 39) we can now code our three SIMPLE REQUESTS as follows:

- 1.1 9=2(72)(i.e. code for Religion equal to 2)
- 1.2 1>21 (i.e. age over 21)
- 1.3 1<25 (i.e. age under 25)

[Note that the ITEM VALUE of the SIMPLE REQUEST 1.1 is followed immediately by the year in brackets. This overcomes the problem created by recording different codes in different years and must also be included with ITEM VALUES corresponding to REQUESTS involving ITEM NOS. 4,6,7,9,36 and 40.]

6. Select the subset of students who are "the fifth child in a family of six".

REQUEST=' 13=0506 '

7. "How many female students are there?"

REQUEST=' 2=F ' or REQUEST=' 2⁻=M '

8. "How many C. of E. students are confirmed?"

REQUEST=' 9=1 (72) & 10=Y '

Note that, as in example 7, there may be more than one acceptable way of coding the REQUEST. In each case however the order of precedence of the Logical Operators is from LEFT to RIGHT. If the answer to a SIMPLE REQUEST is false and this is followed by the Logical Operator &, the whole REQUEST is false. If the answer to a SIMPLE REQUEST is false and this is followed by the Logical Operator |, the next SIMPLE REQUEST is tested. In example 4 for instance if $1 > 25$ is false the whole REQUEST is false, but if $1 > 25$ is true and $3 = 1$ is false the whole REQUEST need not be false since $3 = 2$ is also an acceptable possibility.

This is easier to appreciate if we represent our REQUEST diagrammatically in TREE form as is shown below for example 4; (t and f represent the answer to the SIMPLE REQUEST, true and false respectively).

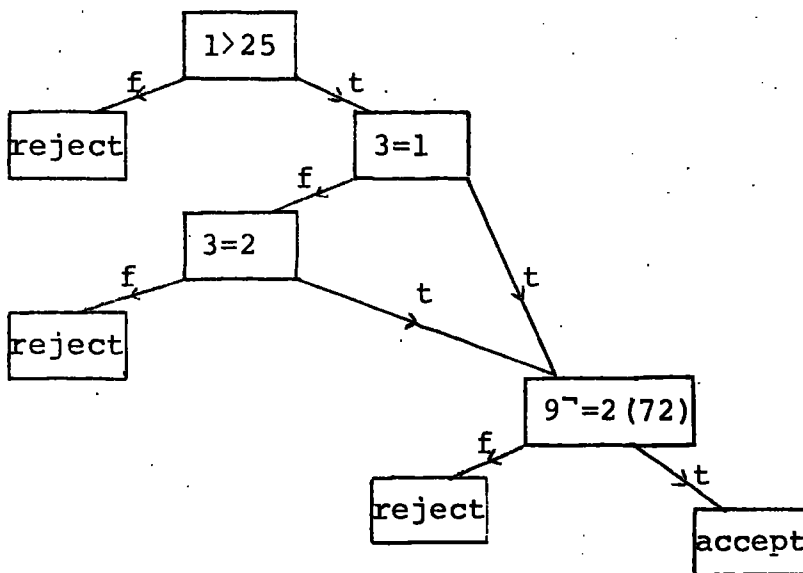

And similarly for example 1 we have:

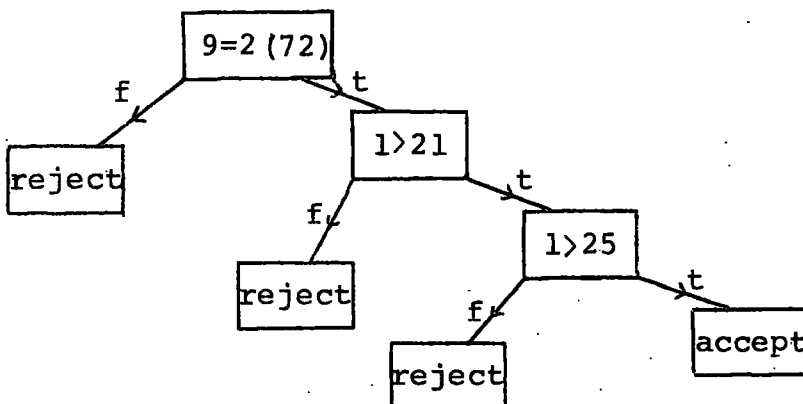

Example 3 like the previous two examples we considered may be broken down into SIMPLE REQUESTS as follows:

- 3.1 has the student 2 A'level passes?
- 3.2 has the student an O'level pass in English Language?
- 3.3 has the student an O'level pass in Mathematics?

Care however must be taken when coding these SIMPLE REQUESTS to ensure that we specify exactly what is required. Take 3.1 for example; the ITEM NO. 21 for qualifications we get from the table, but the ITEM VALUE consists of several parts. To overcome this problem we divide the ITEM VALUE into two parts, NUMBER REQUIRED (MODEL QUALIFICATION). The NUMBER REQUIRED is easily obtained from the SIMPLE REQUEST, the (MODEL QUALIFICATION) however is constructed to meet the requirements of that SIMPLE REQUEST. To explain this let us firstly consider how qualifications are recorded. Each qualification comprises ten characters as given below:

| Year | | Type | | | Code | | | Grade | P or F |
|------|--|------|--|--|------|--|--|-------|--------|
| | | | | | | | | | |

To construct the (MODEL QUALIFICATION) for 3.1 we require the Type to be an A'level and the P or F to be a P. Thus we have:

| Year | | Type | | | Code | | | Grade | P or F |
|------|--|------|--|---|------|--|--|-------|--------|
| | | | | A | | | | | P |

All other characters are then set to * giving the complete (MODEL QUALIFICATION) as:

| Year | | Type | | | Code | | | Grade | P or F |
|------|---|------|---|---|------|---|---|-------|--------|
| * | * | * | * | A | * | * | * | * | P |

This we then combine with the NUMBER REQUIRED to complete the ITEM VALUE, and hence completing the coded form for the SIMPLE REQUEST 3.1 as:

3.1 21>2(****A****P)

Now consider 3.2. Here our (MODEL QUALIFICATION) is constructed with the Type as an O'level, the Code as 061 (i.e. the code for English Language) and the P or F as P. Thus we have:

| Year | | Type | | | Code | | | Grade | P or F |
|------|--|------|--|---|------|---|---|-------|--------|
| | | | | O | 0 | 6 | 1 | | P |

which when completed gives:

| Year | | Type | | | Code | | | Grade | P or F |
|------|---|------|---|---|------|---|---|-------|--------|
| * | * | * | * | 0 | ∅ | 6 | 1 | * | P |

which completes the coded SIMPLE REQUEST for 3.2 as:

3.2 21⁻<1(****0∅61*P)

The SIMPLE REQUEST for 3.3 is similarly formed as:

| Year | | Type | | | Code | | | Grade | P or F |
|------|--|------|--|---|------|---|---|-------|--------|
| | | | | 0 | ∅ | 1 | 1 | | P |

and

| Year | | Type | | | Code | | | Grade | P or F |
|------|---|------|---|---|------|---|---|-------|--------|
| * | * | * | * | 0 | ∅ | 1 | 1 | * | P |

giving the fully coded set of SIMPLE REQUESTS as:

3.1 21>2(****A****P)
 3.2 21⁻<1(****0∅61*P)
 3.3 21⁻<1(****0∅11*P)

and the fully coded REQUEST as:

REQUEST=' 21>2(****A****P) & 21⁻<1(****0∅61*P) | 21⁻<1(****0∅11*P) '

which can be diagrammatically represented as follows:

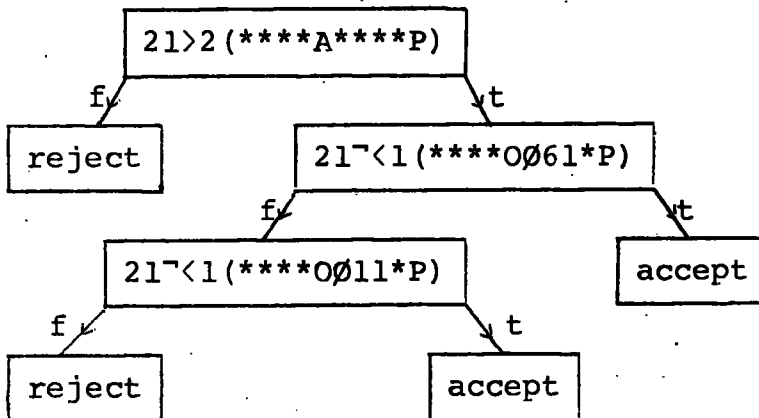

It should be noted that if the SIMPLE REQUESTS 3.1 and 3.2 are both true, then the SIMPLE REQUEST 3.3 is not tested. Hence SIMPLE REQUESTS preceded by the Logical Operator | are not tested if the preceding SIMPLE REQUEST is true.

Consider some further examples:

9. "How many students failed A'level Geography in 1969?"

REQUEST=' 21>Ø(69**AØ52*F) '

10. Select the subset of female students who have "an A'level pass in History".

REQUEST=' 2=F & 21>Ø(****AØ51*P) '

11. Select the subset of students who have "a grade 1, O'level pass in Geography or Latin".

REQUEST=' 21>Ø(****OØ521P) | 21>Ø(****OØ311P) '

12. "How many students have more than 2 CSE passes?"

REQUEST=' 21>2(**CSE***P) '

A similar ITEM VALUE to Qualifications is that of School Type, ITEM NO. 19. In this case the ITEM VALUE is again constructed from two parts, NUMBER REQUIRED (MODEL SCHOOL).

Consider the example:

13. "How many students left a Mixed Grammar School in 1972?"

Diagrammatically the five characters forming the School Type can be represented as:

| School | From | | To | |
|--------|------|--|----|--|
| | | | | |

and adopting the same policy as before in the construction of the (MODEL SCHOOL), we require the School code of 3 (i.e. that for a Mixed Grammar School), and the To date to be 72. Hence we have:

| School | From | | To | |
|--------|------|--|----|---|
| 3 | | | 7 | 2 |

Setting the remaining characters to * we get:

| School | From | | To | |
|--------|------|---|----|---|
| 3 | * | * | 7 | 2 |

which forms the complete (MODEL SCHOOL) giving the coded REQUEST as:

REQUEST=' 19>Ø(3**72) '

Two further examples are:

14. "How many students have attended Colleges of Further Education or Technical Colleges?"

REQUEST=' 19>Ø(9****) '

15. "How many students went to an Independent or Direct Grant School in 1954?"

REQUEST=' 19>Ø(154**) | 19>Ø(254**) '

REQUESTS involving the Annual Progress Vector (ITEM NO.36) take a similar form to those for Qualifications and School Type. In this case, to construct the SIMPLE REQUEST we need to know the Value Required and the Field Label. Since however the same field label may refer to different items in different years, we also require to know the year, relevant to the specified field label. Thus the ITEM VALUE should take the form VALUE REQUIRED(YEAR and FIELD LABEL), where the year should be coded as two digits only, i.e. 69 for 1969, 7Ø for 197Ø and so on.

The following points must be observed:

1. No REQUEST may be more than 4ØØ characters long (including spaces). A REQUEST which requires more than 1 input line (card) must maintain the format specified by the syntax.
2. No REQUEST may consist of more than 2Ø SIMPLE REQUESTS.
3. Programme F allows 1 to 4Ø ITEM NOS. Programme I allows 1 to 66 ITEM NOS. Any reference to an ITEM NO. outside this range will raise the error/warning CLASS G message.

Improperly coded REQUESTS may return incorrect answers or may raise the SYSTEM CONVERSION ERROR ROUTINES in the procedure 'TRANS'.

4. If the ITEM VALUE required is blank, it should be coded as ' ITEM NO.<.'. Since the only character less than '.' is blank, this is equivalent to coding ' ITEM NO.=.' which is invalid.
5. If the ITEM VALUE required contains imbedded blanks, they should be replaced by the character ':' (colon).

The special request: REQUEST='*'

This request allows the user to specify the D.E.S. Nos. of the group of students to be selected and will provide a set of frequency tables for that group. With REQUEST='*' the Option Parameter Card should be followed by the list of D.E.S. Nos. of the students to be included, each punched in columns 1 to 8 of a card and terminated with '*****'.

With this special request the parameters WRL, WCR and FREQ need not be specified.

TABLE OF ITEM NUMBERS, ITEMS AND ITEM VALUES

This table provides a list of the ITEMS used to form a REQUEST. The ITEM VALUES or at least the ranges of the ITEM VALUES have been given wherever possible. In programme F, 1 to 40 ITEM NUMBERS are allowed, and for programme I all the ITEM NUMBERS are allowed.

| ITEM NO. | ITEM | ITEM VALUE |
|----------|-----------------------------------|---------------------------------|
| 1 | Age | two digits, see note 1 |
| 2 | Sex | M and F |
| 3 | Marital Status | 1 to 3 inclusive |
| 4 * | Settlement | 1 to 6, 1 to 4 prior to 1972 |
| 5 | Region | A to K, not coded prior to 1972 |
| 6 * | Parent/Guardian Occupation | 1 to 5, 1 to 6 prior to 1972 |
| 7 * | Student Occupation | 1 to 5, 1 to 6 prior to 1972 |
| 8 | Over 25 Occupation | 0 to 9 and blank |
| 9 * | Religion | 1 to 5, 1 to 6 prior to 1972 |
| 10 | Confirmation | Y and N |
| 11 | Authority/Country | see Appendix 5 |
| 12 | Authority Number | 1 to 5 inclusive |
| 13 | Position in Family | four digits, see note 2 |
| 14 | Start Date | |
| 15 | Univ/Coll Study for Degree | |
| 16 | Univ/Coll awarding Degree | |
| 17 | Title of Degree | |
| 18 | No. of Schools attended | 00 to 10 inclusive, 2 digits |
| 19 * | School Types | |
| 20 | No. of Qualifications recorded | 00 to 30 inclusive, 2 digits |
| 21 * | Qualifications Excepted by A.T.O. | 1 and blank |
| 22 | Length of Course | 1 to 4 and blank |
| 24 * | Current Course Codes | see note 5 |
| 25 | Course Code (admission) | |
| 26 | Details of Course: repetition | see note 3 |
| | Scope of Training: | |
| 27 | 5 to 7 | 1 and blank |
| 28 | 7 to 9 | 1 and blank |
| 29 | 9 to 11 | 1 and blank |
| 30 | 11 to 13 | 1 and blank |
| 31 | over 13 | 1 and blank |
| 32 | Mentally Handicapped | 1 and blank |
| 33 | Not yet decided | 1 and blank |
| 34 | Postgraduate Course | 1 and blank |
| 35 | B.Ed. Course | 1 and blank |
| 36 * | Annual Progress Vector | |
| 37 | Teachers' Certificate | P and F |
| 38 | Wing Science | P and F |
| 39 | B.Ed. | H, P and F |
| 40 * | First Appointment | 1 to 7, A to G prior to 1972 |
| 41-46 | Six Values Scores | 0>=score<=60 |
| 47 | D. Scale Score | 0>=score<=300 |
| 48-50 | Three A.H.4 Scores | 0>=score<=130 |
| 51-66 | Sixteen P.F.16 Scores | 0>=score<=26, see note 4 |

Items marked '*' require additional information.

Note 1: Age is calculated as:

$$\text{AGE} = \text{YEAR OF ADMISSION} - \text{YEAR OF BIRTH}$$

Note 2: The Position in Family comprises 4 digits. The range allowed is from 0101 (i.e. the first child in a family of one) to 9999 (i.e. the 99th child in a family of 99!). In all cases however the first two digits must be less than the second two, since to take an example 0403 (i.e. the fourth child in a family of three) although acceptable is ridiculous.

Note 3: The Details of Course, ITEM NOS. 26 to 35 inclusive, are taken from the latest entry in that section.

Note 4: The upper limit for the range of the P.F.16 tests varies with the test. The upper limit of 26 is the maximum for any test, the exact limits are 20,13,26,26,26,20,26,20,20,26,20,26,20,20,20 and 26 respectively for the factors A,B,C,E,F,G,H,I,L,M,N,O,Q1,Q2,Q3 and Q4.

Note 5: ITEM NO. 24 references the current course codes. To specify the Main Subject code the ITEM VALUE should be followed immediately by the character '1' in brackets. To specify the 2nd Prov. Subject code the character '2' should follow in brackets immediately after the ITEM VALUE.

TABLE OF PARAMETER DEFAULT VALUES

The parameter given in the TABLE OF PARAMETERS (see page 25) will default to the following values if not specified.

| PROGRAMME | OPTION | PARAMETERS | | | | | | | | |
|-----------|--------|------------|---------------------|------|------|----|-----|-----|------|---------|
| | | YT | NTT | DES | PI | VP | WRL | WCR | FREQ | REQUEST |
| R | 1 | | | | | | | | | |
| | 2 | F | 1 | | | | | | | |
| | 3 | | | NULL | | ∅ | | | | |
| | 4 | | | NULL | | ∅ | | | | |
| | 5 | | | | | | | | | |
| | 6 | | | | ∅ | | | | | |
| | 7 | | | NULL | | | | | | |
| | 8 | | | NULL | | ∅ | | | | |
| | 9 | | | | | ∅ | | | | |
| | 10 | | | | NULL | | | | | |
| F | 1 | | | | | | ∅∅∅ | * | | |
| | 2 | | | | | | ∅∅∅ | * | ∅ | NULL |
| I | 1 | F | | | | | ∅∅∅ | * | | |
| | 2 | F | | | | | ∅∅∅ | * | | |
| | 3 | F | | | ∅ | | ∅∅∅ | * | | |
| | 4 | F | | | | | ∅∅∅ | * | | NULL |
| D | | | CLASS B ERROR | | | | | | | |

Table N - 10: Norms for

COLLEGE STUDENTS

MALE: FORM A

(Based on age 21 years; N=1105)

| Fac- tor | 1 | 2 | 3 | 4 | 5 | 6 | 7 | 8 | 9 | 10 | Mean | Stan. Dev. |
|-------------|-----|-----|-------|-------|-------|------------|-------|-------|-------|-------|-------|---------------|
| A | 0-3 | 4 | 5-6 | 7 | 8-9 | 10-11 | 12-13 | 14 | 15-16 | 17-20 | 9.80 | 3.43 |
| B | 0-4 | 5 | - | 6 | 7 | 8 | 9 | 10 | 11 | 12-13 | 7.72 | 1.80 |
| C | 0-7 | 8-9 | 10-11 | 12-13 | 14-15 | 16-17 | 18-19 | 20-21 | 22 | 23-26 | 15.50 | 3.69 |
| E | 0-6 | 7-8 | 9 | 10-11 | 12-13 | 14-16 | 17-18 | 19 | 20-21 | 22-26 | 13.94 | 3.92 |
| F | 0-5 | 6-8 | 9-10 | 11-13 | 14-15 | 16-17 | 18-19 | 20-21 | 22-23 | 24-26 | 15.73 | 4.40 |
| G | 0-4 | 5-6 | 7-9 | 10-11 | 12 | 13-14 | 15-16 | 17 | 18-19 | 20 | 12.73 | 3.60 |
| H | 0-2 | 3-4 | 5-7 | 8-10 | 11-13 | 14-16 | 17-18 | 19-20 | 21-22 | 23-26 | 13.01 | 5.24 |
| I | 0-2 | 3 | 4-5 | 6 | 7-8 | 9-10 | 11-12 | 13-14 | 15 | 16-20 | 8.79 | 3.49 |
| L | 0-3 | 4 | 5-6 | 7 | 8-9 | 10-11 | 12 | 13-14 | 15 | 16-20 | 9.47 | 3.13 |
| M | 0-5 | 6 | 7-8 | 9 | 10-11 | 12-13 | 14-15 | 16-17 | 18 | 19-26 | 11.68 | 3.41 |
| N | 0-5 | 6-7 | 8 | 9 | 10 | 11-12 | 13 | 14-15 | 16 | 17-20 | 11.07 | 2.63 |
| O | 0-3 | 4 | 5-6 | 7-8 | 9 | 10-11 | 12-13 | 14-15 | 17-17 | 18-26 | 10.65 | 3.90 |
| Q1 | 0-4 | 5 | 6 | 7-8 | 9 | 10 | 11-12 | 13 | 14-15 | 16-20 | 9.64 | 2.75 |
| Q2 | 0-3 | 4 | 5-6 | 7 | 8-9 | 10-11 | 12-13 | 14-15 | 17-17 | 18-20 | 9.97 | 3.50 |
| Q3 | 0-3 | 4-5 | 6 | 7-8 | 9-10 | 11 | 12-13 | 14 | 15-16 | 17-20 | 10.14 | 3.07 |
| Q4 | 0-3 | 4 | 5-7 | 8-9 | 10-12 | 13-14 | 15-17 | 18-19 | 20-21 | 22-26 | 12.01 | 4.81 |
| | 1 | 2 | 3 | 4 | 5 | 6 | 7 | 8 | 9 | 10 | | |
| | | | | | | Sten Score | | | | | | |

Table 10: Norms for

COLLEGE STUDENTS

MALE: FORM A

(Based on age 20 years; N=2106)

| Fac- tor | Sten Score | | | | | | | | | | Mean | Stan. Dev. |
|-------------|------------|-----|------|-------|-------|-------|-------|-------|-------|-------|-------|---------------|
| | 1 | 2 | 3 | 4 | 5 | 6 | 7 | 8 | 9 | 10 | | |
| A | 0-3 | 4 | 5-6 | 7-8 | 9 | 10-11 | 12-13 | 14-15 | 16 | 17-20 | 10.08 | 3.43 |
| B | 0-4 | 5 | 6 | 7 | 8 | 9 | 10 | 11 | 12 | 13 | 8.83 | 1.89 |
| C | 0-6 | 7-8 | 9-11 | 12-13 | 14-15 | 16-17 | 18-19 | 20 | 21-22 | 23-26 | 15.14 | 3.90 |
| E | 0-5 | 6-7 | 8-9 | 10-11 | 12-13 | 14-15 | 16-17 | 18-19 | 20-21 | 22-26 | 13.93 | 4.12 |
| F | 0-6 | 7-8 | 9-11 | 12-13 | 14-16 | 17-18 | 19-20 | 21-22 | 23 | 24-26 | 16.44 | 4.52 |
| G | 0-3 | 4-5 | 6-7 | 8-9 | 10-11 | 12-13 | 14-15 | 16-17 | 18 | 19-20 | 11.95 | 3.75 |
| H | 0-2 | 3-4 | 5-7 | 8-10 | 11-13 | 14-17 | 18-19 | 20-22 | 23 | 24-26 | 13.75 | 5.77 |
| I | 0-2 | 3 | 4 | 5-6 | 7-8 | 9-11 | 12-13 | 14 | 15-16 | 17-20 | 9.24 | 3.82 |
| L | 0-2 | 3 | 4-5 | 6-7 | 8 | 9-10 | 11-12 | 13 | 14-15 | 16-20 | 8.97 | 3.34 |
| M | 0-5 | 6-7 | 8 | 9-10 | 11-12 | 13-14 | 15-16 | 17-18 | 19 | 20-26 | 12.69 | 3.62 |
| N | 0-2 | 3 | 4-5 | 6 | 7 | 8-9 | 10 | 11 | 12-13 | 14-20 | 8.25 | 2.68 |
| O | 0-2 | 3-4 | 5-6 | 7 | 8-9 | 10-12 | 13-14 | 15-16 | 17-18 | 19-26 | 10.18 | 3.93 |
| Q1 | 0-3 | 4 | 5-6 | 7-8 | 9 | 10-11 | 12 | 13-14 | 15 | 16-20 | 10.16 | 3.23 |
| Q2 | 0-2 | 3-4 | 5-6 | 7-8 | 9 | 10-11 | 12-14 | 15 | 16-17 | 18-20 | 10.28 | 3.73 |
| Q3 | 0-4 | 5-6 | 7-8 | 9 | 10-11 | 12-13 | 14 | 15-16 | 17 | 18-20 | 11.72 | 3.27 |
| Q4 | 0-3 | 4-5 | 6-7 | 8-10 | 11-12 | 12-13 | 16-17 | 18-19 | 20-21 | 22-26 | 12.77 | 4.82 |
| | 1 | 2 | 3 | 4 | 5 | 6 | 7 | 8 | 9 | 10 | | |
| | Sten Score | | | | | | | | | | | |

6. DATA PREPARATION FOR PROGRAMME R

Several of the options available in programme R require data either as complete records or as amendments to existing records. The format in which this data should be prepared on cards is given in Appendix 2. The following points should be checked by the College before the preparation of the data cards for BCRS.

1. The Authority/Country Name

The Authority/Country recorded in columns 26 to 44 of card 2 (see 2.1 RECORD ADMISSIONS CARD FORMAT) must correspond exactly to one of the Authority/Country names given in the listing in 5.1, Appendix 5.

If the Authority/Country recorded by the student is correct and does not appear on the listing in Appendix 5, verification should be made with the D.E.S. and an appropriate code obtained. The file containing the DATA CONSTANTS should then be amended.

If the recorded entry does not correspond to an Authority/Country name on the listing, programme D will fail to find the required code. A CLASS K error/warning message will be printed and the corresponding field of the Data Interchange admissions card (see card 2, 3.1 CARD OUTPUT ADMISSIONS, Appendix 3) will be left blank.

2. Degree Coding

Although the verification of the degrees held by P.G.C.E. students should not be coded by the College, degree information is required on the listing provided to the D.E.S. with the Data Interchange admissions (see programme R, option 5).

On this listing a distinction is made between degrees awarded by a British Awarding Body and those awarded by a Foreign Awarding Body. To enable BCRS to make this distinction when producing the listing, the University or Other Awarding Body should be preceded by the character 'B' for British or 'F' for Foreign (see column 11, cards 4 and 5 of 2.1 RECORD ADMISSIONS CARD FORMAT, Appendix 2).

3. Other Relevant Qualifications

Other Relevant Qualifications, section L.3 of Form 30 T.T., are coded by the College. To enable BCRS when producing the Data Interchange admissions cards to locate these qualifications, they are coded as 'Special' qualifications on the BCRS admissions cards (see 2.1 card 7 and subsequent cards).

In the case of 'Special' qualifications field G9, the qualification code should be the last three characters of the appropriate qualification code obtained from the list of codes given in 5.6, Appendix 5. Field G10, the qualification grade, should be coded as 'S' for Special.

Although BCRS does check some of the data values on input (see 3.5 DATA CHECKING PROCEDURES) it does not contain checking routines for all the data items. In some cases items may be recorded in error but by checking carefully a listing of the data cards the occurrences of this can be reduced.

7. DATA INTERCHANGE PROCEDURES AND SCHEDULES

The Data Interchange System involves the transmission of data between BCRS and the D.E.S. Computer cards are used as an exchange medium for the majority of the interchange transactions although the possibility of using Magnetic Tapes for the larger transactions is being considered.

Before discussing the procedures involved in the Data Interchange System it is useful to know the form of a student's record within the D.E.S. Data Management System.

In the D.E.S. System a student's record consists of three Sections, A, B and C.

- A) Section A contains mainly permanent details of the student.
- B) Section B contains course details. This section is variable, depending on the course length and course changes, and can consist of from one to ten 'B' modules. A new 'B' module will be added each year as the student progresses through his course, or when the student changes course, or if the student re-enters training after having withdrawn for a short time.
- C) Section C contains the student's surname, previous surname if any, and forename(s).

Although the record format of a BCRS record does not correspond to the above, the Data Interchange System has been developed such that certain transactions carried out on the BCRS records will produce card output. This card output then forms the input to the D.E.S. System, resulting in a similar transaction in that system.

The following transactions have been incorporated in BCRS:

- 1. Transaction 01, Admissions
- 2. Transaction 11, Change of course/subject including the extension to a B.Ed. course
- 3. Transaction 12, Withdrawals/End of course
- 4. Transaction 15, Re-admission, i.e. a transfer from another Training Establishment

Some transactions however require no more than the alteration of a particular field(s) within a specified record, for example a change of D.E.S. Reference Number or a change of Name. These transactions involve no exchange of computer cards as such, but the transaction must be carried out in both systems in order to ensure that subsequent transactions are correct.

In BCRS, programme D is responsible for providing the card output for D.E.S. This output is recorded in a temporary file specified by spunch which when required can be listed and copied to the card punch, *punch*. All cards sent to D.E.S. should be interpreted and accompanied by a corresponding listing.

The following procedures outline the interchange transactions:

1. Transaction 01, Admissions

With this transaction BCRS provides admission records to the D.E.S. The information on the cards produced will be used to establish records in the D.E.S. system.

The Bede College Personal Record Card should be checked by the College with particular reference to the points outlined in the previous section. These cards should then be sent to the UDCU where the records will be prepared on computer cards in the format specified in 2.1, Appendix 2.

Degrees should not be coded and for students who have a degree on admission, a Form 34 T.T. should be completed by the College as at present.

Programme R option 1 will establish the records in a BCRS file and option 10 will prepare the Transaction File for programme D. Since the D.E.S. has to fulfil certain obligations to other D.E.S. Sections/Branches a special listing of the admissions is required. This listing can be obtained from option 5. Programme D should now be run using the Transaction File set up above. The card output will be in the format specified in 3.1, Appendix 3.

The BCRS file can now be copied to tape and the card output together with the two listings and Forms 34 T.T. if any, be sent to the D.E.S.

This transaction should be completed not later than the 30th November. To meet this date the College should send the Record Cards to the UDCU not later than the 15th November.

2. Transaction 11, Change of course/subject

This transaction is used to inform D.E.S. of the new course or subject details of students who change their course/subject. The transaction will establish a new 'B' module in the D.E.S. system.

The new Details of Course should be entered on the Record Card by the College and the card forwarded to the UDCU where the information will be prepared on computer cards in the format specified in 2.5, Appendix 2.

Programme R option 8 will amend the BCRS records by establishing another entry in the Details of Course section, and will produce the Transaction File for programme D. The format of the cards produced by programme D for the D.E.S. is specified in 3.3, Appendix 3.

This transaction should be completed between September and January.

3. Transaction 12, Withdrawals/End of Course

This transaction is used to inform D.E.S. that a student has withdrawn from the College or, having completed his course, has left the College.

Withdrawals: When a student confirms his intention to withdraw, the College should inform the UDCU where a computer card will be prepared in the format specified in 2.4, Appendix 2.

If the student is withdrawing for reason 2 (i.e. transfer to another Training Establishment) the College should also prepare a Form 30 T.T. for that student to forward to the Training Establishment concerned.

Programme R option 4 will amend the BCRS records and prepare the Transaction File for programme D which will produce the card output for D.E.S. in the format specified in 3.2, Appendix 3.

The computer card output, corresponding listings and the Form 30 T.T. when required, should be sent to the D.E.S. as soon as possible after the student has withdrawn.

End of Course: The end of course results should be entered on the Record Cards by the College and forwarded to the UDCU where the information will be prepared on computer cards in the format specified in 2.2, Appendix 2.

BCRS will record a student as leaving if the year of update is equal to the course length.

Verification of the B.Ed. degree will not be coded and the College should prepare Forms 34 T.T. as at present.

Programme R option 3 will update the BCRS records and establish the Transaction File for programme D which will produce card output in the form specified in 3.5, Appendix 3.

The computer card output, corresponding listings and Form 34 T.T. for the B.Ed. students should be forwarded to the D.E.S. not later than the 30th August.

4. Transaction 15, Re-admission, i.e. transfer from another Training Establishment

This transaction is used to provide a link in the D.E.S. system between students who transfer from one Training Establishment to another, and to establish a new 'B' module for those students.

When a student enters College from another Training Establishment, the College should phone the D.E.S. and verify or obtain a D.E.S. Reference Number for that student. When all the information for the Record Card

has been entered, the card should be forwarded to the UDCU where the information will be prepared on computer cards in the format specified in 2.1, Appendix 2.

Programme R option 7 will establish a record for the student in the specified BCRS file, and prepare a Transaction File for programme D. Card output from programme D will be in the format specified in 3.4, Appendix 3.

The cards and their corresponding listings should be sent to the D.E.S. as soon as possible after the student has entered the College.

Other transactions which do not require computer card exchange have been classified into groups 5 and 6. These transactions should be carried out as soon as possible in both Systems to ensure that the records are kept up-to-date and compatible.

5. D.E.S. Transactions

This group contains all transactions made by D.E.S. which necessitate a similar transaction to be made by the College. For example, a change of D.E.S. Reference Number, although in this case the College will receive a 33 T.T. from the D.E.S. as at present.

In all such cases the D.E.S. should inform the College who can then forward the amendments to be made to the UDCU who should update the records appropriately as soon as possible.

6. College Transactions

College transactions include any alteration made to the Records by the College which will necessitate a similar transaction in BCRS and in the D.E.S. System, for example a change of Name.

With this type of transaction the College should inform D.E.S. and the UDCU who should amend the records concerned as soon as possible.

APPENDIX 1

- 1.1 Bede College Personal Record Card (1972)
- 1.2 Course Results 1969
1970
1971
1972
- 1.3 D.E.S. Form 30 T.T.



BEDE COLLEGE DURHAM

PERSONAL RECORD CARD

CERTIFICATE, B.Ed. or P.G.C.E. (Institute) STUDENT

CARD A

PHOTO

| | | | | | |
|--|---|---------------------------|-------------|--------------|--|
| Permanent home address Phone: | leave blank | D.E.S. No. | / A1 | | |
| | Surname BLOCK CAPITALS → | A2 | | | |
| | Original Surname if different → | B1 | | | |
| | Forenames BLOCK CAPITALS → | A3 | | | |
| Changes of address (leave blank) Phone: | TITLE Mr. Mrs. Miss → | A4 | | SEX M/F → | A5 |
| | Age..... yrs..... mths. Date of birth → e.g. 6/8/48 | Day A6 | Month A7 | Year 19A8 | A9 |
| Phone: | Teacher Training | From | To | | |
| | | A10 | A11 | A12 | |
| | Marital status Tick one | single | married | div/widowed | |
| Classification of area in which brought up (see leaflet "Page 1, Notes 1a, 1b") Phone: | Region | A14 | 1 | | Address code (leave blank) <div style="border: 1px solid black; width: 80px; height: 40px; margin: 0 auto;"></div> |
| | Settlement classification | A15 | 2 | | |
| Position in family (e.g. 1/1 only child, 2/4 second of four) | | A16/A17 | | | |
| Classification of occupation of parent or guardian (see leaflet "Page 1, Note 2") | | A18 | | | |
| Classification of student's previous occupation (see leaflet "Page 1, Note 2") if "School" leave blank. | | A19 | | | |
| If you are <u>over 25</u> , tick the appropriate box at the right to indicate your occupation at the date of acceptance of the course If you are <u>under 25</u> leave this section blank | Teaching or youth service | 1 | 1 | | |
| | Central or Local Government | 2 | 2 | | |
| | H.M. Forces | 3 | 3 | | |
| | Police | 4 | 4 | | |
| | Nursing | 5 | 5 | | |
| | Other Medical or Welfare Service... | A20 | 6 | | |
| | Banking, Insurance, or Accountancy | 7 | 7 | | |
| | Commerce | 8 | 8 | | |
| | Industry | 9 | 9 | | |
| | Other ... | 0 | 0 | | |
| Next of kin or person to be informed in case of an emergency Name | Religion (tick one) | C. of E. | 1 | | |
| | | R.C. | A21 | | 2 |
| | | Nonconformist | 3 | | |
| | | Other religion | 4 | | |
| | | Humanist/Agnostic/Atheist | 5 | | |
| Address | confirmed (or equiv.) tick | | Yes | Year: 19A2B | |
| | | | No | | |

Type of Student
Complete the line that is appropriate to you by making an entry in the box on the right

| | | Authority or country | |
|--|--|----------------------|-------|
| Student recognised for grant by an English or Welsh local ed. auth., a Channel Island or Isle of Man auth. | State the name of the authority by whom you are recognised for grant | | |
| Student recognised for grant by the Dept. of Ed. and Sci. for a course at a University department | State the name of the local education authority in whose area you live | 1 | |
| Student assisted by the Scottish Ed. Dept. or the Ministry of Education for Northern Ireland | State either 'Scotland' or 'Northern Ireland' | B2 | 2 A24 |
| Private United Kingdom student | State the name of the local education authority in whose area you live | 3 | |
| Private overseas student | State your home country | 4 | |
| Student seconded on salary by an English or Welsh local education authority | State the name of the local education authority by whom you are seconded | 5 | |

SECONDARY AND FURTHER, HIGHER EDUCATION

Please give details of all schools, colleges etc. where you studied from the age of 11 and all external academic examinations taken (including multiple attempts).

DES No. Leave Blank

/ A1

See leaflet for example and coding scheme.

| School, etc. names and addresses | Type code | Year entd. | Year left | EXAMINATIONS | | | Code | Grade | Pass or Fail |
|----------------------------------|-----------|------------|-----------|--------------|------|---------|------|-------|--------------|
| | | | | Year | Type | Subject | | | |
| G2 ... No. of Schools recorded | G4 | G5 | G6 | G7 | G8 | | G9 | G10 | G11 |
| | | | | | | | | | |
| | | | | | | | | | |
| | | | | | | | | | |
| | | | | | | | | | |
| | | | | | | | | | |
| | | | | | | | | | |
| | | | | | | | | | |
| | | | | | | | | | |
| | | | | | | | | | |
| | | | | | | | | | |
| | | | | | | | | | |
| | | | | | | | | | |
| | | | | | | | | | |
| | | | | | | | | | |
| | | | | | | | | | |
| | | | | | | | | | |
| | | | | | | | | | |
| | | | | | | | | | |

G3 ... No. of qualifications recorded

| | | | | | | | | | | |
|--|---|-----------------|-------------|-------------------------|------------------|-----|---------------|-----|----|--|
| Study for degree(s) entered below (leave blank if not applicable) | University or College attended for degree study | | | Full time or part time? | From | | | To | | |
| | C1 | C2 | C3 | C4 | C5 | C6 | C7 | C8 | | |
| | C9 | C10 | C11 | C12 | C13 | C14 | C15 | C16 | | |
| Degree(s) held (leave blank if not applicable) | University or other degree awarding body | Title of Degree | Hons., Pass | Class Division | Main Subject(s)* | | Date of Award | | | |
| | D1 | D2 | D3 | D4 | D5 | | D6 | D7 | D8 | |
| | E1 | E2 | E3 | E4 | E5 | | D6 | E7 | E8 | |

* Do not show subjects taken at subsidiary level

| | | | |
|--|---|----|----|
| Advanced Art Qualifications Place a tick in the box on the right against either of the qualifications shown which you hold Other Art Qualifications (give details) | Diploma in Art and Design | F1 | F2 |
| | National Diploma in Design together with pass in Min. of Ed. Inter. Art & Craft Exam. | F4 | F3 |
| | 1 | F6 | F5 |
| | 2 | | F7 |

Student exempted by A.T.O. from examination requirements (Leave blank) G1

COLLEGE CAREER (ACADEMIC)

CARD B

| | | | |
|--|-----------|-------|----|
| Length of course to be followed in years | | Codes | B3 |
| Main Subject or B.Ed. Option | 1st | | B4 |
| | 2nd/Prov. | | B5 |
| Leave Blank | | | |

| | |
|------------------------|------|
| D.E.S. No. leave blank | / A1 |
| Surname BLOCK CAPITALS | |
| Forenames | |

DETAILS OF COURSE (OFFICE USE ONLY)

| Duration of course etc. | | | | | | | | | | | | Scope of training | | | | | | | | | | | | | | | | | | | | | | | | | | | | | | | | | | |
|--------------------------|------------|----------------------------|----|----|----|----|----|----------------------------------|----|------|------------|-------------------|---------|-------------------------------------|--------|--------|---------|----------|---------|----------------------|-----------------|--------------------|----|----|-------------------------------|----|----------------------|--------------|-----|-----|-----|-----|-----|-----|-----|-----|-----|-----|-----|-----|-----|-----|-----|-----|-----|-----|
| Year of student's course | Repetition | Date student's year begins | | | | | | Expected end of student's course | | | | | | A.T.O. approval to shortened course | 5 to 7 | 7 to 9 | 9 to 11 | 11 to 13 | Over 13 | Mentally Handicapped | Not yet decided | Number of subjects | | | Code numbers of main subjects | | Post graduate course | B.Ed. Course | | | | | | | | | | | | | | | | | | |
| | | M | Y | M | Y | M | Y | M | Y | Main | Subsidiary | Undecided | 46 - 48 | | | | | | | | | 49 - 51 | 59 | 64 | | | | | | | | | | | | | | | | | | | | | | |
| 24 | 25 | 26 | 27 | 28 | 29 | 30 | 31 | 32 | 33 | 34 | 35 | 36 | 37 | 38 | 41 | 42 | 43 | 44 | 45 | 46 - 48 | 49 - 51 | 59 | 64 | B6 | B7 | B8 | B9 | B10 | B11 | B12 | B13 | B14 | B15 | B16 | B17 | B18 | B19 | B20 | B21 | B22 | B23 | B24 | B25 | B26 | B27 | B28 |

Course Results

| Year | Main Subject or B.Ed. option | Education | | Group: | Basic Courses (Unit based) | | | | | | | | | |
|-----------------------------------|------------------------------|-----------|-----|------------|------------------------------------|------------|--------------------|-------|-------------|---------|-----------------------|------------|--|---|
| | | 1 | 2 | | Prin. | Prac. | A. College Courses | | | | B. Curricular Courses | | | C |
| | | | | | Eng. | P.E. | R.S. | Maths | Description | Code | Score | H.Ed. | | |
| 1 | | | | | Individual Scores/10 | | | | | | | | | |
| | | | | | Totals /40 | | | | | | | | | |
| | | | | | Result | June P/F | | | June P/F | | | June P/F | | |
| | | | | | | Subseq P/F | | | Subseq P/F | | | Subseq P/F | | |
| | | | | | Overall, Year 1 unit based courses | June P/F | | | Subseq P/F | | | Subseq P/F | | |
| 2 | | | Bl. | St.Pr. | Session 1 | Eng. | P.E. | R.S. | Maths | | | | | |
| | | | | | Individual Scores /15 | | | | | | | | | |
| | | | | | Session 2 | | | | | | | | | |
| | | | | | Individual Scores /10 | | | | | | | | | |
| | | | | | Total/100 /95 | | | | | | | | | |
| Overall Year 2 Unit based courses | June P/F | | | Subseq P/F | | | Subseq P/F | | | | | | | |
| 3 | | | | | Curriculum and other Courses | | | | Code | Result. | | | | |
| | | | | | | | | | | | | | | |
| | | | | | | | | | | | | | | |
| B.Ed. Q | | Pass | | 1 | | | | | | | | | | |
| | | Fail | | 2 | | | | | | | | | | |

FINAL RESULT

| | | |
|-----------------------|-------|--|
| Teachers' Certificate | Pass | |
| | Fail | |
| Wing Science | Pass | |
| | Fail | |
| B.Ed. | Hons. | |
| | Pass | |
| | Fail | |

| B.Ed. Final | Options | | Ed. | Overall | |
|---------------------|---------|---|-----|---------|--|
| | 1 | 2 | | Hons. | |
| June (1) | | | | Pass | |
| | | | | Fail | |
| June (2) subsequent | | | | Pass | |
| | | | | Fail | |
| June (3) subsequent | | | | Pass | |
| | | | | Fail | |

Personal Tutor:.....

TUTORS' REPORTS. (compiled by P.T.)

Any Main Subject Comment.

YEAR 1

YEAR 2

YEAR 3
(B.Ed.)

See also testimonial/confidential report in file

SUBSEQUENT CAREER

Further Qualifications:

| | | |
|---|--------|---|
| Schoc., F.E., Coll. of Ed. (not Indep.) E. & W. | | 1 |
| School, F.E., Coll. of Ed. (not Indep.) S. & NI | | 2 |
| Indep. school. | U.K. | 3 |
| Any other tchg. | U.K. | 4 |
| Any other tchg. | abroad | 5 |
| Further e.t. | | 6 |
| Non-teaching | | 7 |

FIRST APPOINTMENT: School address

Home address

SUBSEQUENT CHANGE OF HOME ADDRESS:

1.2 COURSE RESULTS

FIELD LABELS FOR COURSE RESULTS, 1969 ADMISSIONS

Course Results

OFFICE USE ONLY

| Year | Main Subject or B.Ed. option | | Education | | | Eng. | R.K. | P.E. | Maths | Curriculum and other Courses (inc. Study Practice) | Code | Result |
|------|------------------------------|-----|-----------|-------|------|------|------|------|-------|--|------|--------|
| | 1st | 2nd | Prin. | Prac. | H.E. | | | | | | | |
| 1 | A1 | A2 | A3 | A4 | A5 | A6 | A7 | A8 | A9 | | | |
| 2 | A10 | A11 | A12 | A13 | A14 | A15 | A17 | A19 | A21 | A23 | | |
| | | | | | | A16 | A18 | A20 | A22 | | | |
| 3 | A24 | A25 | A26 | A27 | A28 | A29 | A30 | A31 | A32 | | | |

| | | | |
|--------------|------|-----|-----|
| B.Ed. 1 June | A33 | A34 | A35 |
| Sept. | A36 | A37 | A38 |
| Final result | Pass | | 1 |
| | Fail | A39 | 2 |

Internal grades BLACK: A-E
 Institute grades RED: D, C, P, F.
 University grades RED:
 B.Ed. 1:
 B.Ed. FINALS: J, K, L, M.
 Ed. Prac. Yr. 1&2. 1, 2, 3, F
 S.U.M.
 Ed. Prac. Yr. 3. D.P.F.

| | | | | | | | | | | | | |
|---|-----|-----|-----|--|--|--|--|--|--|--|--|--|
| 4 | A40 | A41 | A42 | | | | | | | | | |
|---|-----|-----|-----|--|--|--|--|--|--|--|--|--|

| | | | |
|------------------|-----|-----|-----|
| B.Ed. Final June | A43 | A44 | A45 |
| Sept. | A46 | A47 | A48 |
| June | A49 | A50 | A51 |
| Sept. | A52 | A53 | A54 |

FIRST APPOINTMENT

| | |
|--|---|
| School, F.E., Coll of Ed. (not indep) E. & W. | A |
| School, F.E., Coll of Ed. (not indep.) S. & NI | B |
| Indep. school. U.K. | C |
| Any other tchg. U.K. | D |
| Any other tchg. abroad | E |
| Further t.t. | F |
| Non-teaching | G |

FINAL RESULT

| | | |
|-----------------------|--------|---|
| Teacher's Certificate | Div. 1 | 1 |
| | 2 | 2 |
| | Fall | 3 |
| Wing Science | Div. 1 | 4 |
| | 2 | 5 |
| | Fall | 6 |
| B.Ed. | Div. 1 | 7 |
| | 2 | 8 |
| | 3 | 9 |
| | Fall | 0 |

FIELD LABELS FOR COURSE RESULTS, 1970 ADMISSIONS

Course Results

OFFICE USE ONLY

| Year | Main Subject or B.Ed. option | | Education | | | Eng. | R.K. | P.E. | Maths | Curriculum and other Courses (inc. Study Practice) | Code | Result |
|------|------------------------------|-----|-----------|-------|------|------|------|------|-------|--|------|--------|
| | 1st | 2nd | Prin. | Prac. | H.E. | | | | | | | |
| 1 | A1 | A2 | A3 | A4 | A5 | A6 | A7 | A8 | A9 | A10 A11 A12 A13 | | |
| 2 | A14 | A15 | A16 | A17 | A18 | A19 | A21 | A23 | A25 | | | |
| | | | | | | A20 | A22 | A24 | A26 | | | |
| 3 | A27 | A28 | A29 | A30 | A31 | | | | | | | |

| | | | |
|--------------|------|-----|-----|
| B.Ed. June | A32 | A33 | A34 |
| Sept. | A35 | A36 | A37 |
| Final result | Pass | | 1 |
| | Fail | A38 | 2 |

Internal grades BLACK: A-E
 Institute grades RED: D,C, P, F.
 University grades RED:
 B.Ed. I: J, K, L, M.
 B.Ed. FINALS: 1, 2, 3, F.
 S.U.M.
 Ed. Prac. Yr. 1&2.
 Ed. Prac. Yr. 3. D.P.F.

| | | | | | | | | | | | | |
|---|-----|-----|-----|--|--|--|--|--|--|--|--|--|
| | | | | | | | | | | | | |
| 4 | A39 | A40 | A41 | | | | | | | | | |

| | | | |
|------------------|-----|-----|-----|
| B.Ed. Final June | A42 | A43 | A44 |
| Sept. | A45 | A46 | A47 |
| June | A48 | A49 | A50 |
| Sept. | A51 | A52 | A53 |

FIRST APPOINTMENT

| | |
|--|---|
| School, F.E., Coll of Ed. (not indep) E. & W. | A |
| School, F.E., Coll of Ed. (not indep.) S. & NI | B |
| Indep. school. U.K. | C |
| Any other tchg. U.K. | D |
| Any other tchg. abroad | E |
| Further t.t. | F |
| Non-teaching | G |

FINAL RESULT

| | | |
|-----------------------|--------|---|
| Teacher's Certificate | Div. 1 | 1 |
| | 2 | 2 |
| | Fail | 3 |
| Wing Science | Div. 1 | 4 |
| | 2 | 5 |
| | Fail | 6 |
| | B.Ed. | |
| B.Ed. | Div. 1 | 7 |
| | 2 | 8 |
| | 3 | 9 |
| | Fail | 0 |

ELD LABELS FOR COURSE RESULTS, 1971 ADMISSIONS

Course Results OFFICE USE ONLY

| Year | Main Subject or B.Ed. option | | Education | | Group: | Basic Courses (Unit based) | | | | | | | | | | | | | | | | |
|---|------------------------------|-----|-----------|-------|------------------------------|----------------------------|------|------------|-------|-----------------------|-----------------------------------|-----------------------|-----------|-----|----------|-----|-----|----------|-----|--|--|--|
| | 1 | 2 | Prin. | Prac. | | A. College Courses | | | | B. Curriculum Courses | | | C | | | | | | | | | |
| | | | | | | Eng. | P.E. | R.K. | Maths | Description | Code | Score | H.Ed. | | | | | | | | | |
| 1 | A1 | A2 | A3 | A4 | Individual Scores/10 | A5 | A6 | A7 | A8 | A9 | A10 | A11 | A21 | | | | | | | | | |
| | | | | | | | | | | A12 | A13 | A14 | A22 | | | | | | | | | |
| | | | | | | | | | | A15 | A16 | A17 | A23 | | | | | | | | | |
| | | | | | | | | | | A18 | A19 | A20 | A24 | | | | | | | | | |
| | | | | | | | | | | Totals /40 | A25 | | | | A26 | | | A27 | | | | |
| | | | | | | | | | | Result | June P/F | | | A28 | June P/F | | A29 | June P/F | A30 | | | |
| | Subseq P/F | | | A31 | Subseq P/F | | A32 | Subseq P/F | A33 | | | | | | | | | | | | | |
| Overall, Year 1 unit based courses | June P/F | | | A34 | | | | | | | | | | | | | | | | | | |
| | Subseq P/F | | | A35 | | | | | | | | | | | | | | | | | | |
| | Subseq P/F | | | A36 | | | | | | | | | | | | | | | | | | |
| 2 | A37 | A38 | A39 | A40 | A41 | Session 1 | Eng. | P.E. | R.K. | Maths | | | | | | | | | | | | |
| | | | | | | | | | | | Individual Scores /15 | A42 | A43 | A44 | A45 | | | | | | | |
| | | | | | | | | | | | Session 2 | Individual Scores /10 | A46 | A47 | A48 | A49 | | | | | | |
| | | | | | | | | | | | | | Total/100 | | | | A50 | | | | | |
| | | | | | | | | | | | | | | | A51 | | | | | | | |
| | | | | | | | | | | | Overall Year 2 Unit based courses | June P/F | | | A52 | | | | | | | |
| Subseq P/F | | | A53 | | | | | | | | | | | | | | | | | | | |
| Subseq P/F | | | A54 | | | | | | | | | | | | | | | | | | | |
| B.Ed. I June | | | A55 | | | | | | | | | | | | | | | | | | | |
| | | | A56 | | | | | | | | | | | | | | | | | | | |
| Sept. | | | A57 | | | | | | | | | | | | | | | | | | | |
| Final Result | Pass | A58 | | 1 | | | | | | | | | | | | | | | | | | |
| | Fail | | | 2 | | | | | | | | | | | | | | | | | | |
| 3 | A59 | A60 | A61 | A62 | Curriculum and other Courses | | Code | Result | | | | | | | | | | | | | | |
| | | | | | A63 | | A64 | A65 | | | | | | | | | | | | | | |
| | | | | | A66 | | A67 | A68 | | | | | | | | | | | | | | |
| B.Ed. Final June | | | A69 | A70 | A71 | | | | | | | | | | | | | | | | | |
| Sept. | | | A72 | A73 | A74 | | | | | | | | | | | | | | | | | |
| June | | | A75 | A76 | A77 | | | | | | | | | | | | | | | | | |
| Sept. | | | A78 | A79 | A80 | | | | | | | | | | | | | | | | | |
| FIRST APPOINTMENT | | | | | | | | | | | | | | | | | | | | | | |
| School, F.E., Coll of Ed. (not indep) E. &W. | | | | | | A | | | | | | | | | | | | | | | | |
| School, F.E., Coll of Ed. (not indep) S. & NI | | | | | | B | | | | | | | | | | | | | | | | |
| Indep. school. U.K. | | | | | | C | | | | | | | | | | | | | | | | |
| Any other tchg. U.K. | | | | | | D | | | | | | | | | | | | | | | | |
| Any other tchg. abroad | | | | | | E | | | | | | | | | | | | | | | | |
| Further t.t. | | | | | | F | | | | | | | | | | | | | | | | |
| Non-teaching | | | | | | G | | | | | | | | | | | | | | | | |
| FINAL RESULT | | | | | | | | | | | | | | | | | | | | | | |
| Teacher's Certificate | | | | | | Div. 1 | | 1 | | | | | | | | | | | | | | |
| | | | | | | 2 | | 2 | | | | | | | | | | | | | | |
| Wing Science | | | | | | Fail | | 3 | | | | | | | | | | | | | | |
| | | | | | | Div. 1 | | 4 | | | | | | | | | | | | | | |
| | | | | | | 2 | | 5 | | | | | | | | | | | | | | |
| B.Ed. | | | | | | Fail | | 6 | | | | | | | | | | | | | | |
| | | | | | | Div. 1 | | 7 | | | | | | | | | | | | | | |
| | | | | | | 2 | | 8 | | | | | | | | | | | | | | |
| | | | | | | 3 | | 9 | | | | | | | | | | | | | | |
| | | | | | | Fail | | 0 | | | | | | | | | | | | | | |

Internal grades BLACK: A-E or numeral
 Ed. Prac. Years 1 & 2 S, U, M.
 Institute grades RED:
 (Incl. Ed. Prac. Year 3) D, P, F.
 University grades BLACK: B.Ed. I, J, K, L, M.
 B.Ed. Finals 1, 2, 3, F.

FIELD LABELS FOR COURSE RESULTS, 1972 ADMISSIONS

| Main Subject or B.Ed. option | | Education | | Basic Courses (Unit based) | | | | | | | | | | | | | | |
|------------------------------------|-----|-----------|-------|----------------------------|------------------------------|---------------------------------|-----------------------------------|-----------------------|------|------------|----------|-----|-----|------------|-----|----------|-----|-----|
| 1 | 2 | Prin. | Prac. | A. College Courses | | | | B. Curriculum Courses | | | C | | | | | | | |
| Group: | | | | Eng. | P.E. | R.S. | Maths | Description | Code | Score | H.Ed. | | | | | | | |
| Year 1 | A1 | A2 | A3 | A4 | Individual Scores/10 | A5 | A6 | A7 | A8 | A9 | A10 | A11 | A21 | | | | | |
| | | | | | | | | | | A12 | A13 | A14 | A22 | | | | | |
| | | | | | | | | | | A15 | A16 | A17 | A23 | | | | | |
| | | | | | | | | | | A18 | A19 | A20 | A24 | | | | | |
| | | | | | | Totals /40 | | | | A25 | | | | A26 | | | A27 | |
| | | | | | | Result | | | | June P/F | | | | A28 | | June P/F | | A29 |
| | | | | Subseq P/F | | | | A31 | | Subseq P/F | | A32 | | Subseq P/F | A33 | | | |
| Overall, Year 1 unit based courses | | | | June P/F | | | | A34 | | | | | | | | | | |
| | | | | Subseq P/F | | | | A35 | | | | | | | | | | |
| | | | | Subseq P/F | | | | A36 | | | | | | | | | | |
| 2 | A37 | A38 | A39 | A40 | A41 | Session 1 Individual Scores /15 | Eng. | P.E. | R.S. | Maths | | | | | | | | |
| | | | | | | | A42 | A43 | A44 | A45 | | | | | | | | |
| | | | | | | | Session 2 Individual Scores /10 | A46 | A47 | A48 | A49 | | | | | | | |
| | | | | | | | | Total/100 /95 | | | | A50 | | | | | | |
| | | | | | | | | | | | | A51 | | | | | | |
| | | | | | | | Overall Year 2 Unit based courses | | | | June P/F | | | | A52 | | | |
| | | | | Subseq P/F | | | | A53 | | | | | | | | | | |
| | | | | Subseq P/F | | | | A54 | | | | | | | | | | |
| 3 | A55 | A56 | A57 | A58 | Curriculum and other Courses | | | | Code | Result | | | | | | | | |
| | | | | | A59 | | | | A60 | A61 | | | | | | | | |
| | | | | | A62 | | | | A63 | A64 | | | | | | | | |
| B.Ed. Q. | | Pass | A65 | 1 | | | | | | | | | | | | | | |
| | | Fail | | 2 | | | | | | | | | | | | | | |

| B.Ed. Final | Options | | Ed. | Overall | |
|---------------------|---------|-----|-----|---------|-----|
| | 1 | 2 | | Hons. | |
| June (1) | A66 | A67 | A68 | Pass | A69 |
| | | | | Fail | |
| June (2) subsequent | A70 | A71 | A72 | Pass | A73 |
| | | | | Fail | |
| June (3) subsequent | A74 | A75 | A76 | Pass | A77 |
| | | | | Fail | |

FINAL RESULT

| | | |
|-----------------------|-------|--|
| Teachers' Certificate | Pass | |
| | Fail | |
| Wing Science | Pass | |
| | Fail | |
| B.Ed. | Hons. | |
| | Pass | |
| | Fail | |

DEPARTMENT OF EDUCATION AND SCIENCE
TRAINEE TEACHER'S RECORD CARD

Instructions to student
1. Use BLOCK LETTERS
2. Complete the unshaded parts where applicable: do not make any entries on the shaded parts
3. If you need any help in completing this form you should ask the authorities of the training establishment you are attending

| | | | | | | | | | | | | | | | | | | | | | | | | | | | |
|---|--|--|--|-------|----------------------|---|------------------|---|---------------------------|---|-----------------------------|---|-------------|---|--------|---|---------|---|-----------------------------------|---|-----------------------------------|---|----------|---|----------|----|-------|
| A Reference Number | I Date of Birth in figures, e.g. 6 8 48 | | Day | Month | Year | Certification (by Training Establishment) | | | | | | | | | | | | | | | | | | | | | |
| | B Date of Birth in figures, e.g. 6 8 48 | | | | | | | | | | | | | | | | | | | | | | | | | | |
| C Name | C Surname Fore Names | | | | | | | | | | | | | | | | | | | | | | | | | | |
| D Residence | E Home address:— | | | | | | | | | | | | | | | | | | | | | | | | | | |
| F Teacher Training under D.E.S. Regulations | Name of Training Establishment | | From | | To | | Estab. No. | | | | | | | | | | | | | | | | | | | | |
| G Study for degree(s) entered at H below (see blank if not applicable) | BEDE COLLEGE DURHAM | | University or College attended for degree study | | Result of course | | 9625 | | | | | | | | | | | | | | | | | | | | |
| H Degree(s) held (leave blank if not applicable) | Title of Degree | | Main Subject(s) | | Date of Award | | (For D.E.S. use) | | | | | | | | | | | | | | | | | | | | |
| I Type of Student | Student recognised for grant by an English or Welsh local education authority, a Channel Island or Isle of Man authority | | State the name of the authority by whom you are recognised for grant | | Authority or country | | For D.E.S. use | | | | | | | | | | | | | | | | | | | | |
| | Student recognised for grant by the Department of Education and Science for a course at a University department | | State the name of the local education authority in whose area you live | | | | 1 | | | | | | | | | | | | | | | | | | | | |
| J Previous Employment | Student assisted by the Scottish Education Department or the Ministry of Education for Northern Ireland | | State either 'Scotland' or 'Northern Ireland' | | | | 2 | | | | | | | | | | | | | | | | | | | | |
| | Private United Kingdom student | | State the name of the local education authority in whose area you live | | | | 3 | | | | | | | | | | | | | | | | | | | | |
| | Private overseas student | | State your home country | | | | 4 | | | | | | | | | | | | | | | | | | | | |
| | Student seconded on salary by an English or Welsh local education authority | | State the name of the local education authority by whom you are seconded | | | | 5 | | | | | | | | | | | | | | | | | | | | |
| | | | | | | | | | | | | | | | | | | | | | | | | | | | |
| <p>If you are 25 years of age or over place a tick in the appropriate box on the right to indicate your occupation at the date of acceptance for the course. If you are under 25 leave this Section blank</p> <table border="1"> <tr><td>1</td><td>Teaching or youth service</td></tr> <tr><td>2</td><td>Central or local government</td></tr> <tr><td>3</td><td>H.M. Forces</td></tr> <tr><td>4</td><td>Police</td></tr> <tr><td>5</td><td>Nursing</td></tr> <tr><td>6</td><td>Other medical or welfare services</td></tr> <tr><td>7</td><td>Banking, insurance or accountancy</td></tr> <tr><td>8</td><td>Commerce</td></tr> <tr><td>9</td><td>Industry</td></tr> <tr><td>11</td><td>Other</td></tr> </table> | | | | | | | | 1 | Teaching or youth service | 2 | Central or local government | 3 | H.M. Forces | 4 | Police | 5 | Nursing | 6 | Other medical or welfare services | 7 | Banking, insurance or accountancy | 8 | Commerce | 9 | Industry | 11 | Other |
| 1 | Teaching or youth service | | | | | | | | | | | | | | | | | | | | | | | | | | |
| 2 | Central or local government | | | | | | | | | | | | | | | | | | | | | | | | | | |
| 3 | H.M. Forces | | | | | | | | | | | | | | | | | | | | | | | | | | |
| 4 | Police | | | | | | | | | | | | | | | | | | | | | | | | | | |
| 5 | Nursing | | | | | | | | | | | | | | | | | | | | | | | | | | |
| 6 | Other medical or welfare services | | | | | | | | | | | | | | | | | | | | | | | | | | |
| 7 | Banking, insurance or accountancy | | | | | | | | | | | | | | | | | | | | | | | | | | |
| 8 | Commerce | | | | | | | | | | | | | | | | | | | | | | | | | | |
| 9 | Industry | | | | | | | | | | | | | | | | | | | | | | | | | | |
| 11 | Other | | | | | | | | | | | | | | | | | | | | | | | | | | |

K Ref. No. (as at A overleaf) _____ **I Date of Birth (in figures)** _____ **Surname (BLOCK LETTERS)** _____

L EXAMINATIONS PASSED (OTHER THAN FINAL DEGREE EXAMINATIONS) AND QUALIFICATIONS OBTAINED BEFORE ENTRY INTO TRAINING
 L.1 Do not complete this Section if you hold a degree conferred in the United Kingdom. If you have obtained passes in an English or Welsh General Certificate of Education or Certificate of Secondary Education examination or have gained an English or Welsh School Certificate complete this Section in respect of those passes. Enter details of other certificates in Section L.2.

G.C.E. Advanced Level. Enter grade of pass below the subject(s) in which you have obtained G.C.E. (A) level pass(es). (Omit any G.C.E. (O) level results).

| | | | | | | | | | | | | | | | | | | | | | | | | | | | | | | | | | | | |
|---|---|---|-------------|----------------------|-----------|---------|---------|-------------------|----------|--|---------------------|-------------------------------|-----------|---|-----------------------------------|--|---|--|--|-------------------------------------|---------|-----------|---------|-------------------|---------|-------------------|----------|-------------------------------------|---------|---------|-----------|---|-----------------------------------|------------------|-----------------|
| Have you obtained English or Welsh School Certificate, G.C.E. (Grade) for G.C.E. (O) level? | Number of passes obtained in the following examinations | Tick the appropriate box(es) below if you have passed these examinations in English or Welsh School Certificate, G.C.E. (Grade) for G.C.E. (O) level. | | Scientific/Technical | | | | | | | | | | | | | | | | | | | | Social/Vocational | | | | | | | | | | | |
| | | English Language | Mathematics | Physics | Chemistry | Biology | Geology | Technical Drawing | Woodwork | Other Science or technical subjects | English | History | Geography | Other Social Science or Vocational Subjects | Needlework or Vocational Subjects | Domestic Science | General Studies | | | | | | | | | | | | | | | | | | |
| 20 | 21/22 23/24 25/26 27 28 29 | English Literature | French | Latin | Greek | German | Italian | Spanish | Russian | Other Modern Languages (see instructions page 2) | Religious Knowledge | Art and Craft (incl. pastels) | Art | Music | Other Art Subjects | Pure Mathematics (incl. double subjects) | Applied Mathematics (incl. double subjects) | Pure and Applied Mathematics (incl. double subjects) | Advanced Mathematics (incl. double subjects) | Mathematics (incl. double subjects) | Physics | Chemistry | Zoology | Botany | Ecology | Technical Drawing | Woodwork | Other Science or technical subjects | English | History | Geography | Other Social Science or Vocational Subjects | Needlework or Vocational Subjects | Domestic Science | General Studies |

L.2 Advanced Art Qualifications
 Place a tick in the box on the right against either of the qualifications shown which you hold.

L.3 Other relevant qualifications (including Irish Leaving Certificate)

L.4 Student exempted by A.T.O. from examination requirements

M DETAILS OF COURSE (No entries to be made in columns marked † except on instructions from D.E.S.)

| M.1 Duration of course etc. | M.2 Scope of training | M.3 Initial courses for non-graduates (other than holders of specialist qualifications) | M.4 One year courses for holders of specialist qualifications | | | M.5 Post graduate courses | M.6 Technical teacher training | M.7 Other Information |
|-----------------------------|-------------------------------|---|---|----------------------------|---|---|---|---|
| | | | Year of student's course | Date student's year begins | Expected end of student's course | | | |
| Wholly full time | Wholly part time | Other | Year of student's course | Date student's year begins | Expected end of student's course | Year of specialist's course | Type of course | Subject Group |
| 31 32 | 33 34 35 36 37 38 39 40 41 42 | 43 44 45 46 48 | 47 48 49 50 51 52 53 54 55 56 57 58 59 | 60 61 62 63 64 65 66 67 | 68 69 70 71 72 73 74 75 76 77 78 79 80 81 82 83 84 85 86 87 88 89 90 91 92 93 94 95 96 97 98 99 100 | 101 102 103 104 105 106 107 108 109 110 111 112 113 114 115 116 117 118 119 120 121 122 123 124 125 126 127 128 129 130 131 132 133 134 135 136 137 138 139 140 141 142 143 144 145 146 147 148 149 150 151 152 153 154 155 156 157 158 159 160 161 162 163 164 165 166 167 168 169 170 171 172 173 174 175 176 177 178 179 180 181 182 183 184 185 186 187 188 189 190 191 192 193 194 195 196 197 198 199 200 | 201 202 203 204 205 206 207 208 209 210 211 212 213 214 215 216 217 218 219 220 221 222 223 224 225 226 227 228 229 230 231 232 233 234 235 236 237 238 239 240 241 242 243 244 245 246 247 248 249 250 251 252 253 254 255 256 257 258 259 260 261 262 263 264 265 266 267 268 269 270 271 272 273 274 275 276 277 278 279 280 281 282 283 284 285 286 287 288 289 290 291 292 293 294 295 296 297 298 299 300 | 301 302 303 304 305 306 307 308 309 310 311 312 313 314 315 316 317 318 319 320 321 322 323 324 325 326 327 328 329 330 331 332 333 334 335 336 337 338 339 340 341 342 343 344 345 346 347 348 349 350 351 352 353 354 355 356 357 358 359 360 361 362 363 364 365 366 367 368 369 370 371 372 373 374 375 376 377 378 379 380 381 382 383 384 385 386 387 388 389 390 391 392 393 394 395 396 397 398 399 400 |

N Amendments (Other than Section I)

FOR USE BY TRAINING ESTABLISHMENT

821958 274 671 888 D0720N Cp 960:1

Exclude passes in any subjects which you have also passed at G.C.E. 'O' level.

APPENDIX 2. BCRS DATA CARD FORMATS

- 2.1 Record Admissions card format
- 2.2 Record Updating card format
- 2.3 Intelligence Tests card format
- 2.4 Withdrawals card format
- 2.5 Course/Subject Changes card format

In the following punching specifications the column headed SECTION refers to the field sections marked on the Bede College Personal Record Card, Appendix 1.

2.1. RECORD ADMISSION CARD FORMAT

Card 1

| Columns | Field Designation | Section | Notes |
|---------|---------------------------|-------------|-------------------------------|
| 1- 8 | D.E.S. No. | A1 | 8 characters |
| 9-48 | Surname, Forenames | A2 A3 | See 1) below |
| 50-51 | Title | A4 | See 2) below |
| 52 | Sex | A5 | Code M or F |
| 53-58 | Date of Birth | A6 A7 A8 | 6 characters, see 3) below |
| 59 | Date of Birth Certificate | A9 | Code 1 if ticked |
| 60-65 | Teacher Training from | A10 All A12 | 6 characters, see 3) below |
| 66 | Marital Status | A13 | Code 1, 2 or 3 |
| 67 | Region | A14 | |
| 68 | Settlement | A15 | |
| 69-72 | Position in Family | A16 A17 | 4 characters, see 4) below |
| 73 | Parent Occupation | A18 | |
| 74 | Student Occupation | A19 | |
| 75 | Over 25 Question | A20 | Code 0 to 9 or blank |
| 76 | Religion | A21 | Code 1 to 5 |
| 77 | Confirmation | A22 | Code Y or N |
| 78-79 | Year of Confirmation | A23 | 2 characters |
| 80 | Authority number | A24 | Code 1 to 5 |

- 1) Surname to be left justified and followed by a comma.
Forenames to be left justified, each preceded by a space.

E.g. WILSON, JAMES ROBERT
↑
column 9

- 2) Code M1 for Mr., M2 for Mrs., or M3 for Miss.
- 3) All dates to be recorded as DDMMYY. Insert leading zeros where necessary.
E.g. for 2/4/70 code 020470
- 4) Insert leading zeros where necessary.

Card 2

| Columns | Field Designation | Section | Notes |
|---------|-------------------------------|-----------|--------------|
| 1- 8 | D.E.S. No. | A1 | 8 characters |
| 9-25 | Previous Surname if different | B1 | See 1) below |
| 26-44 | Authority or Country | B2 | See 2) below |
| 45 | Length of Course | B3 | |
| 46-48 | Main Subject | B4 | See 3) below |
| 59-51 | 2nd/Prov. Subject | B5 | See 3) below |
| 52-80 | Details of Course | B6 to B28 | See 4) below |

- 1) Previous Surname to be left justified.
- 2) Authority or Country to be left justified.
- 3) Insert leading zeros where necessary.
- 4) Details of Course to be coded as follows:

| | | | |
|-------|----------------------------------|-------------|----------------------------|
| 52 | Year of Student's Course | B6 | |
| 53 | Repetition | B7 | |
| 54-57 | Date Student's Course begins | B8 B9 B10 | 4 characters, see 5) below |
| 58-61 | Expected end of Student's Course | B11 B12 B13 | 4 characters, see 5) below |
| 62 | A.T.O. approved | B14 | |
| | Scope of Training: | | |
| 63 | 5 to 7 | B15 | Code 1 if ticked |
| 64 | 7 to 9 | B16 | |
| 65 | 9 to 11 | B17 | |
| 66 | 11 to 13 | B18 | |
| 67 | over 13 | B19 | |
| 68 | Mentally Handicapped | B20 | |
| 69 | Not yet decided | B21 | |
| 70 | No. of subjects: Main | B22 | |
| 71 | Subsid. | B23 | |
| 72 | Undecided | B24 | |
| 73-75 | Main Subjects | B25 | 3 characters, see 6) below |
| 76-78 | Main subjects | B26 | 3 characters, see 6) below |
| 79 | Postgraduate Courses | B27 | |
| 80 | B.Ed. Course | B28 | |

- 5) Dates to be recorded as MMY. Insert leading zeros where necessary.
- 6) Insert leading zeros where necessary.

Card 3 (optional)

| Columns | Field Designation | Section | Notes |
|---------|-----------------------------------|-------------|-------------------------------|
| 1- 8 | D.E.S. No. | A1 | 8 characters |
| 9-10 | Continuation Marker | | Code 'C1' |
| 11-31 | University or College attended | C1 | See 1) below |
| 32 | Full/Part time | C2 | Code P or F |
| 33-38 | From date | C3 C4 C5 | 6 characters, see 2) below |
| 39-44 | To date | C6 C7 C8 | 6 characters, see 2) below |
| 45-65 | University or College attended | C9 | See 1) below |
| 66 | Full/Part time | C10 | Code P or F |
| 67-72 | From date | C11 C12 C13 | 6 characters, see 2) below |
| 73-78 | To date | C14 C15 C16 | 6 characters, see 2) below |
| 79-80 | Blank | | |

- 1) University or College attended to be left justified.
- 2) All dates to be coded as DDMMYY. Insert leading zeros where necessary.

Cards 4 and 5 (optional)

| Columns | Field Designation | Section | Notes |
|---------|--------------------------------------|----------|------------------------------|
| 1- 8 | D.E.S. No. | A1 | 8 characters |
| 9-10 | Continuation Marker | | Code 'C2' |
| 11 | British or Foreign Body | D1 | Code B or F see 1) below |
| 12-31 | University or other Awarding Body | D1 | See 1) below |
| 32-34 | Title of Degree | D2 | See 2) below |
| 35-38 | Hons/Pass Class/Division | D3 D4 | See 3) below |
| 39-74 | Main Subjects | D5 | 3 groups of 12 characters |
| 75-80 | Date of Award | D6 D7 D8 | 6 characters |
| 1- 8 | D.E.S. No. | A1 | 8 characters |
| 9-10 | Continuation Marker | | Code 'C3' |
| 11 | British or Foreign Body | D1 | Code B or F see 1) below |
| 12-31 | University or other Awarding Body | E1 | See 1) below |
| 32-34 | Title of Degree | E2 | See 2) below |
| 35-38 | Hons/Pass Class/Division | E3 E4 | See 3) below |
| 39-74 | Main Subjects | E5 | 3 groups of 12 characters |
| 75-80 | Date of Award | E6 E7 E8 | 6 characters |

- 1) University of other Awarding Body to be left justified, and should begin with the letter 'B' if a British awarding body or 'F' if a Foreign awarding body.
- 2) Title of Degree, code BSC, MSC, MA, BA, PHD, right justified.
- 3) Hons/Pass Class/Division, for Hons first code H1.0
 2.1 H2.1
 2.2 H2.2
 third H3.0
 Pass first P1.0
 second P2.0
 third P3.0

Card 6 (optional)

| Columns | Field Designation | Section | Notes |
|---------|---|---------|---------------------------------|
| 1- 8 | D.E.S. No. | A1 | 8 characters |
| 9-10 | Continuation Marker | | Code 'C4' |
| 11-31 | Diploma in Art and Design | F1 | See 1) below |
| 32 | Diploma confirmed | F2 | Code 1 if ticked |
| 33 | National Diploma confirmed | F3 | Code 1 if ticked |
| 34-52 | Other Art Qualifications 1 | F4 | See 1) below |
| 53-56 | Other Art Qualifications 1 confirmed | F5 | Code 4 character code if any |
| 57-76 | Other Art Qualifications 2 | F6 | See 1) below |
| 77-80 | Other Art Qualifications 2 confirmed | F7 | Code 4 character code if any |

- 1) Diploma in Art and Design, Other Art Qualifications 1, and Other Art Qualifications 2 to be left justified.

Card 7 and Subsequent Cards

| Columns | Field Designation | Section | Notes |
|------------------|--|---------------------------|--------------|
| 1- 8 | D.E.S. No. | A1 | 8 characters |
| 9 | Blank | | |
| 10 | Student excepted by A.T.O. | G1 | |
| 11 | Blank | | |
| 12-13 | No. of Schools attended (N) | G2 | See 1) below |
| 14-15 | No. of Qualifications recorded (M) | G3 | See 1) below |
| 16+ | N groups of 5 characters if N is EVEN leave 5 blanks M groups of 10 characters | G4 G5 G6 G7 to G11 | See 2) below |
| Subsequent Cards | | | |
| 1- 8 | D.E.S. No. | A1 | 8 characters |
| 9-10 | Blank | | |
| 11+ | Remainder of M groups of 10 characters | G7 to G11 | See 2) below |

1) Number of Schools (N) and Number of Qualifications (M), insert leading zeros where required.

2) Code as follows:

| Year | Type | Subject | Code | Grade | Pass or Fail |
|------|------|---------|------|-------|--------------|
| G7 | G8 | | G9 | G10 | G11 |

G7 2 characters
 G8 3 characters, right justified
 G9 3 characters, insert leading zero when required
 G10 1 character
 G11 1 character, P or F

2.2 RECORD UPDATING CARD FORMAT

The information stored in the Annual Progress Vector varies greatly depending on the course structure adopted from year to year by the College. Due to this no fixed format is provided and the information should be punched on cards along with a 'field label' signifying the field to which it belongs. The maximum number of different field labels allowed is 100, labelled A1 to A100 (see Course Results, pp.53-56).

The following general formatting rules should be observed.

1. Each card should contain the D.E.S. No. in columns 1 to 8.
2. Column 9 should contain the Year of Update: 1,2,3 or 4.
3. Column 10 should contain the character 'C' if the Year of Update is 3 and the student is proceeding to a B.Ed. or 4th year.

Column 10 should contain the character 'F' on the card giving the Final Result, First Appointment and Leaving Date, (see rule 8 below).

4. Punch each field as *field label=field value*
E.g. *A1=B+* *A23=PASS*
5. The '*' forming the first character of the first field on any card should be punched in column 11 of that card. Thereafter the initial '*' of subsequent fields should be punched in the next available column positions 21,31, 41,51,61 or 71.
6. No field may cross a card boundary and if more than one card is required the character 'C' should be placed in column 80 and punching continued in the same manner on the next card.
7. The fields may appear in any order.
8. The Final Result, First Appointment and Leaving Date should be punched according to the following specified format:

| Columns | Field Designation |
|---------|--|
| 1- 8 | D.E.S. No. |
| 10 | the character 'F' |
| 20 | Final Result ... Teachers' Certificate |
| 30 | Final Result ... Wing Science |
| 40 | Final Result ... B.Ed. |
| 50 | First Appointment |
| 60-65 | Leaving date, code as DDMYY |

2.3 INTELLIGENCE TESTS CARD FORMAT

| Columns | Field Designation | |
|---------|-------------------|---|
| 1- 8 | D.E.S. No. | |
| 9-20 | Values scores | 6 two digit numbers |
| 21-23 | D. Scale score | 1 three digit number |
| 24-30 | A.H.4 scores | 2 two digit numbers, 1 three digit number |
| 31-62 | 16 P.F. scores | 16 two digit numbers |
| 63-80 | blank | |

Any record containing missing values should be ignored

2.4 WITHDRAWALS CARD FORMAT

| Columns | Field Designation |
|---------|--|
| 1- 8 | D.E.S. No. |
| 9 | blank |
| 10-15 | Date of withdrawal 6 characters, code as DDMMYY |
| 16 | blank |
| 17 | Reason for withdrawal 1 character code |
| 18-80 | blank |

2.5 COURSE/SUBJECT CHANGES CARD FORMAT

| Columns | Field Designation | Section | Notes |
|---------|----------------------------------|---------|-------------------------------|
| 1- 8 | D.E.S. No. | A1 | |
| 9 | blank | | |
| 10 | Update title | | Code 'C' or 'S' |
| 11-51 | blank | | |
| 52 | Year of Student's Course | see 3) | |
| 53 | Repetition | below | |
| 54-57 | Date Student's Course begins | | 4 characters, see 1) below |
| 58-61 | Expected end of Student's Course | | 4 characters, see 1) below |
| 62 | A.T.O. approved | | |
| | Scope of Training: | | |
| 63 | 5 to 7 | | Code 1 if ticked |
| 64 | 7 to 9 | | |
| 65 | 9 to 11 | | |
| 66 | 11 to 13 | | |
| 67 | over 13 | | |
| 68 | Mentally handicapped | | |
| 69 | Not yet decided | | |
| 70 | No. of subjects: Main | | |
| 71 | Subsid. | | |
| 72 | Undecided | | |
| 73-75 | Main Subjects | | 3 characters, see 2) below |
| 76-78 | Main Subjects | | 3 characters, see 2) below |
| 79 | Postgraduate Courses | | |
| 80 | B.Ed. Course | | |

- 1) Dates to be recorded as MMY. Insert leading zeros where necessary.
- 2) Insert leading zeros where necessary.
- 3) Columns 52 to 80 should contain the LATEST ENTRY in the section marked DETAILS OF COURSE, B6 to B28.

APPENDIX 3. D.E.S. DATA INTERCHANGE CARD FORMATS

- 3.1 Card output admissions
- 3.2 Card output withdrawals
- 3.3 Card output change of course/subject
- 3.4 Card output re-admission
- 3.5 Card output end of course

In the following card output specifications the column headed SECTION refers to the field sections marked on the D.E.S. form 3Ø T.T., Appendix 1.

3.1 CARD OUTPUT ADMISSIONS

Card 1

| Columns | Field Designation | Section | Notes |
|---------|---------------------------|---------|-----------------------------------|
| 1- 7 | D.E.S. No. | A | 7 characters, see 1) below |
| 8 | Sex | | Coded 1 for male, 2 for female |
| 9-13 | Date of Birth | B | 5 characters, see 2) below |
| 14 | Date of Birth Certificate | B | Code 1 if ticked |
| 15-32 | Surname | C | See 3) below |
| 33-63 | Forenames | C | See 3) below |
| 64-73 | Blank | | |
| 74-76 | Batch No. | | Coded '999' |
| 77-78 | Transaction Code | | Coded 'Ø1' |
| 79-8Ø | Card No. | | Coded 'Ø1' |

- 1) D.E.S. No. to be coded without oblique stroke.
E.g. for 7Ø/42168 code 7Ø42168
- 2) Dates coded as DDMYY. For months January to September code numbers 1 to 9, for October code '&', for November code '-', for December code 'Ø'.
- 3) Surname and Forenames to be left justified. Forenames should be separated by a space. Hyphens are acceptable, apostrophes should be coded as '.'.
E.g. O'Connell-Smith coded as O.Connell-Smith

Card 2

| Columns | Field Designation | Section | Notes |
|---------|----------------------------------|---------|------------------------------------|
| 1- 7 | D.E.S. No. | A | See Card 1 |
| 8 | Sex | | See Card 1 |
| 9-13 | Date of Birth | B | See Card 1 |
| 14-19 | First 6 letters of Surname | C | To be left justified |
| 20-21 | Blank | | |
| 22-38 | Previous Surname if different | C | See 1) below |
| 39-41 | Home County or Country | D | |
| 42-46 | Date Course begins | F | Date format, see Card 1, note 2 |
| 47-50 | Establishment No. | F | Coded as '9625' for BEDE |
| 51-54 | Blank | | |
| 55 | Degree Verification | H | |
| 56-58 | Blank | | |
| 59-69 | Degrees | H | |
| 70 | Type of Student | I | |
| 71 | Previous Employment | J | |
| 72-73 | Blank | | |
| 74-76 | Batch No. | | Coded '999' |
| 77-78 | Transaction Code | | Coded '01' |
| 79-80 | Card No. | | Coded '02' |

- 1) Previous Surname to be left justified. Hyphens and apostrophes coded as for Card 1, note 3. If more than one previous surname, separate by a space.

Card 3

| Columns | Field Designation | Section | Notes |
|---------|----------------------------------|---------|----------------------|
| 1- 7 | D.E.S. No. | K | See Card 1 |
| 8 | Sex | | See Card 1 |
| 9-13 | Date of Birth | K | See Card 1 |
| 14-19 | First 6 letters of Surname | K | To be left justified |
| 20 | School Certificate obtained | L.1 | Code 1 if ticked |
| 21-22 | No. of Grade 1 C.S.E. Passes | L.1 | See 1) below |
| 23-24 | No. of Passes, G.C.E. O'levels | L.1 | See 1) below |
| 25-26 | No. of Passes, G.C.E. A'levels | L.1 | See 1) below |
| 27 | Blank | | |
| 28 | English Language: C.S.E. Grade 1 | L.1 | Code 1 if ticked |
| | G.C.E. O'level | L.1 | |
| 29 | Mathematics: C.S.E. Grade 1 | L.1 | Code 1 if ticked |
| | G.C.E. O'level | L.1 | |
| 30-69 | G.C.E. A'level Passes | L.1 | See 2) below |
| 70-73 | Blank | | |
| 74-76 | Batch No. | | Coded '999' |
| 77-78 | Transaction Code | | Coded '01' |
| 79-80 | Card No. | | Coded '03' |

- 1) No. of passes to be right justified, leading zeros inserted where necessary.
- 2) A'level passes. Grades to be recorded in appropriate columns as given below:

| | |
|----|---|
| 30 | English Literature |
| 31 | Welsh Language |
| 32 | Latin |
| 33 | Greek |
| 34 | French |
| 35 | German |
| 36 | Italian |
| 37 | Spanish |
| 38 | Russian |
| 39 | Other Modern Languages (not elsewhere specified) |
| 40 | History |
| 41 | Ancient History |
| 42 | Religious Knowledge |
| 43 | Art |
| 44 | Art and Craft (excluding Needlework) |
| 45 | Music |
| 46 | Other Art Subjects |
| 47 | Pure Mathematics (including double subject) |
| 48 | Applied Mathematics (including double subject/statistics) |
| 49 | Pure and Applied Mathematics (single subject) |
| 50 | Additional Mathematics (including Higher/Further) |
| 51 | Mathematics (not elsewhere specified) |
| 52 | Physics |
| 53 | Chemistry |
| 54 | Botany |
| 55 | Zoology |

Card 3 (continued)

| | |
|----|---|
| 56 | Biology |
| 57 | Geology |
| 58 | Technical Drawing |
| 59 | Metalwork |
| 60 | Woodwork |
| 61 | Other Science or Technical Subjects |
| 62 | English Economic History |
| 63 | British Constitution |
| 64 | Economics |
| 65 | Geography |
| 66 | General Studies |
| 67 | Domestic Subjects (excluding Needlework) |
| 68 | Needlework |
| 69 | Other Social Science or Vocational Subjects |

Card 4 (Optional)

| Columns | Field Designation | Section | Notes |
|---------|---|---------|----------------------|
| 1- 7 | D.E.S. No. | K | See Card 1 |
| 8 | Sex | | See Card 1 |
| 9-13 | Date of Birth | K | See Card 1 |
| 14-19 | First 6 letters of Surname | K | To be left justified |
| 20-21 | Blank | | |
| 22 | Diploma in Art and Design | L.2 | Code 1 if ticked |
| 23 | Advanced (National Diploma) | L.2 | Code 1 if ticked |
| 24-27 | Advanced (Other Qualifications) | L.2-1 | |
| 28-31 | Advanced (Other Qualifications) | L.2-2 | |
| 32-35 | Other relevant Qualifications | L.3 | |
| 36-39 | Other relevant Qualifications | L.3 | |
| 40-43 | Blank | | |
| 44 | Exception from Examination requirements | L.4 | Code 1, 2 or 3 |
| 45-73 | Blank | | |
| 74-76 | Batch No. | | Coded '999' |
| 77-78 | Transaction Codes | | Coded '01' |
| 79-80 | Card No. | | Coded '04' |

| Columns | | Section | |
|---------|-------------------------------------|---------|-------------|
| 1- 7 | D.E.S. No. | K | See Card 1 |
| 8 | Sex | | See Card 1 |
| 9-13 | Date of Birth | K | See Card 1 |
| 14-19 | First 6 letters of Surname | K | See Card 2 |
| 20 | Blank | | |
| 21 | Type of course: F/T | M.1 | Coded 'F' |
| 22 | Type of course: P/T | M.1 | |
| 23 | Type of course: Other | M.1 | |
| 24 | Year of Student's Course | M.1 | |
| 25 | Repetition | M.1 | |
| 26-28 | Date Student's Year begins | M.1 | |
| 29-31 | Expected end of Course | M.1 | |
| 32 | A.T.O. approved to Shortened Course | M.1 | |
| 33 | Under 5 | M.2 | |
| 34 | 5 to 7 | M.2 | |
| 35 | 7 to 9 | M.2 | |
| 36 | 9 to 11 | M.2 | |
| 37 | 11 to 13 | M.2 | |
| 38 | Over 13 | M.2 | |
| 39-40 | Blank | | |
| 41 | Mentally Handicapped | M.2 | |
| 42 | Not yet decided | M.2 | |
| 43 | No. of Subjects: Main | M.3 | |
| 44 | No. of Subjects: Subsidiary | M.3 | |
| 45 | No. of Subjects: Undecided | M.3 | |
| 46-48 | Main Subject Codes | M.3 | |
| 49-51 | Main Subject Codes | M.3 | |
| 52-54 | Main Subject Codes | M.3 | |
| 55-57 | Main Subject Codes | M.3 | |
| 58 | One Year Courses | M.4 | |
| 59 | Postgraduate Courses | M.5 | |
| 60 | Technical Teach. Training: Course | M.6 | |
| 61-63 | Subject | M.6 | |
| 64 | B.Ed. Course | M.6 | |
| 65-73 | Blank | | |
| 74-76 | Batch No. | | Coded '999' |
| 77-78 | Transaction Code | | Coded '01' |
| 79-80 | Card No. | | Coded '05' |

3.2 CARD OUTPUT WITHDRAWALS

| Columns | Field Designation | Section | Notes |
|---------|-------------------------------|---------|--------------------------------|
| 1- 7 | D.E.S. No. | A | 7 characters, see 3.1, note 1) |
| 8 | Sex | | Coded 1 for Male, 2 for Female |
| 9-13 | Date of Birth | B | 5 characters, see 3.1, note 2) |
| 14-19 | First 6 characters of Surname | C | Left justified |
| 20-24 | To date | F | 5 characters, see 3.1, note 2) |
| 25-28 | Establishment No. | F | Coded as '9625' |
| 29 | Withdrawal Code | O | See GENERAL CODES, Appendix 5 |
| 30-32 | Date of Withdrawal | O | Coded MYY, 3 characters only |
| 33-73 | Blank | | |
| 74-76 | Batch No. | | Coded '999' |
| 77-78 | Transaction Code | | Coded '12' |
| 79-80 | Blank | | |

3.3 CARD OUTPUT CHANGE OF COURSE/SUBJECT

Card 1

| Columns | Field Designation | Section | Notes |
|---------|-------------------------------|---------|----------------------------------|
| 1- 7 | D.E.S. No. | A | 7 characters, see 3.1, note 1) |
| 8 | Sex | | Coded 1 for Male 2 for Female |
| 9-13 | Date of Birth | B | 5 characters, see 3.1, note 2) |
| 14-19 | First 6 characters of Surname | C | Left justified |
| 20-46 | Blank | | |
| 47-50 | Establishment No. | F | Coded '9625' |
| 51-73 | Blank | | |
| 74-76 | Batch No. | | Coded '999' |
| 77-78 | Transaction Code | | Coded '11' |
| 79-80 | Card No. | | Coded '02' |

Card 2

| Columns | Field Designation | Section | Notes |
|---------|-------------------------------|---------|-----------------------------------|
| 1- 7 | D.E.S. No. | A | 7 characters, see 3.1, note 1) |
| 8 | Sex | | Coded 1 for Male, 2 for Female |
| 9-13 | Date of Birth | B | 5 characters, see 3.1, note 2) |
| 14-19 | First 6 characters of Surname | C | Left justified |
| 20 | Blank | | |
| 21-64 | Details of Course | M | See 3.1 Card 5, columns 20-64 |
| 65-73 | Blank | | |
| 74-76 | Batch No. | | Coded '999' |
| 77-78 | Transaction Code | | Coded '11' |
| 79-80 | Card No. | | Coded '05' |

3.4 CARD OUTPUT RE-ADMISSION

Card 1

| Columns | Field Designation | Section | Notes |
|---------|-------------------------------|---------|--------------------------------|
| 1- 7 | D.E.S. No. | A | 7 characters, see 3.1, note 1) |
| 8 | Sex | | Coded 1 for Male, 2 for Female |
| 9-13 | Date of Birth | B | 5 characters, see 3.1, note 2) |
| 14-19 | First 6 characters of Surname | C | Left justified |
| 20-41 | Blank | | |
| 42-46 | Date Course begins | F | 5 characters, see 3.1, note 2) |
| 47-50 | Establishment No. | F | Coded '9625' |
| 51-73 | Blank | | |
| 74-76 | Batch No. | | Coded '999' |
| 77-78 | Transaction Code | | Coded '15' |
| 79-80 | Card No. | | Coded '02' |

Card 2

| Columns | Field Designation | Section | Notes |
|---------|-------------------------------|---------|--------------------------------|
| 1- 7 | D.E.S. No. | A | 7 characters, see 3.1, note 1) |
| 8 | Sex | | Coded 1 for Male, 2 for Female |
| 9-13 | Date of Birth | B | 5 characters, see 3.1, note 2) |
| 14-19 | First 6 characters of Surname | C | Left justified |
| 20-64 | Details of Course | M | See 3.1 Card 5, columns 20-64 |
| 75-73 | Blank | | |
| 74-76 | Batch No. | | Coded '999' |
| 77-78 | Transaction No. | | Coded '15' |
| 79-80 | Card No. | | Coded '05' |

3.5 CARD OUTPUT END OF COURSE

| Columns | Field Designation | Section | Notes |
|---------|-------------------------------|---------|--------------------------------|
| 1- 7 | D.E.S. No. | A | 7 characters, see 3.1, note 1) |
| 8 | Sex | | Coded 1 for Male, 2 for Female |
| 9-13 | Date of Birth | B | 5 characters, see 3.1, note 2) |
| 14-19 | First 6 characters of Surname | C | Left justified |
| 20-39 | Blank | | |
| 40 | Result | E | |
| 41 | Result Certification | E | |
| 42 | Intention | E | |
| 43-47 | To date | F | 5 characters, see 3.1, note 2) |
| 48-51 | Establishment No. | F | Coded '9625' |
| 52 | Degree Certification | H | |
| 53-66 | Degree | H | |
| 67-73 | Blank | | |
| 74-76 | Batch No. | | Coded '999' |
| 77-78 | Transaction No. | | Coded '12' |
| 79-80 | Blank | | |

APPENDIX 4. BCRS ERROR/WARNING MESSAGES

ERROR/WARNING MESSAGES

The classification of error and warning messages which may arise when using the programmes R, F, I and D have been divided into three groups as follows:

- Group 1 TERMINAL ERRORS CLASS A and CLASS B error/warning messages are raised by terminal errors which will result in programme termination.
- Group 2 ERRORS CLASS C to CLASS K error/warning messages are raised by errors which will not terminate programme execution. The specified action should be taken by the user where possible.
- Group 3 WARNINGS CLASS L to CLASS R error/warning messages provide warnings to the user and no further action need be taken.

Explanation of each classification takes the following form:

- CLASS i: MESSAGE : The message printed by the computer when this classification of error/warning arises.
- PROGRAMME : The programme in which this message appears.
- OPTIONS : The options in the programme specified above, which may raise this classification of error/warning (not specified in programme D).
- MEANING : The reason for the error/warning.
- COMPUTER ACTION : The action taken by the computer when such an error/warning is encountered.
- USER ACTION : The action which should be taken by the user.

CLASS A: MESSAGE : OPTION INVALID PROGRAM TERMINATED

PROGRAMME : R, F and I

OPTIONS : All

MEANING : An option has been requested which does not exist.

COMPUTER ACTION : The programme will terminate execution.

USER ACTION : Check the Option requested.

CLASS B: MESSAGE : TRANSACTION FILE NOT SPECIFIED
EXECUTION TERMINATED

PROGRAMME : D

MEANING : The filename of the file containing the D.E.S. Nos. and transaction codes has not been specified.

COMPUTER ACTION : Execution is terminated.

USER ACTION : Check the parameter DES, it should contain the name of the required file.

CLASS C: MESSAGE : D.E.S. NO. CANNOT BE FOUND ... DATA IGNORED

PROGRAMME : R

OPTIONS : 2, 3, 4, 8 or 9

MEANING : The D.E.S. No. supplied with this set of data is not known within the specified file.

COMPUTER ACTION : Check the D.E.S. No. of the data that was rejected. Check the filename, it may be that you are searching in the wrong file.

CLASS D: MESSAGE : D.E.S. NO. TYPE WARNING ... SET TO 3

PROGRAMME : R

OPTIONS : 5 or 6

MEANING : The student is not recorded as having a course length of 1, 2 or 3 years, nor as a P.G.C.E. student.

COMPUTER ACTION : The programme will assume the length to be 3 years and will continue.

USER ACTION : Check and alter the course length.

CLASS E: MESSAGE : D.E.S. NO. ERROR RETURNED ... AGE
D.E.S. NO. ERROR RETURNED ... SEX
D.E.S. NO. ERROR RETURNED ... MARITAL STATUS
D.E.S. NO. ERROR RETURNED ... RELIGION
D.E.S. NO. ERROR RETURNED ... SETTLEMENT
D.E.S. NC. ERROR RETURNED ... PARENT/GUARDIAN OCC.
D.E.S. NO. ERROR RETURNED ... STUDENT OCCUPATION
D.E.S. NO. ERROR RETURNED ... OVER 25 QUESTION
D.E.S. NO. ERROR RETURNED ... REGION
D.E.S. NO. ERROR RETURNED ... SCHOOL TYPE
D.E.S. NO. ERROR RETURNED ... FAMILY POSITION
(xx/xx)

PROGRAMME : F

OPTIONS : 1 or 2

MEANING : The information recorded for the specified item is out of range.

COMPUTER ACTION : The information recorded is ignored and the programme continues.

USER ACTION : Check the item recorded, it is probably improperly coded. N.B. a family position greater than the 10th child of 10 will raise this condition.

CLASS F: MESSAGE : D.E.S. NO. ERROR RETURNED FOR VALUES SCORE k
D.E.S. NO. ERROR RETURNED FOR D.SCALE SCORE
D.E.S. NO. ERROR RETURNED FOR A.H.4 SCORE k
D.E.S. NO. ERROR RETURNED FOR P.F.16 SCORE k

PROGRAMME : I

OPTIONS : 2 or 4

MEANING : The kth score is out of range.

COMPUTER ACTION : The score is ignored and the programme continues.

USER ACTION : Check the recorded score.

CLASS G: MESSAGE : ERROR ITEM xxx NOT INCLUDED

PROGRAMME : F

OPTIONS : 2

PROGRAMME : I

OPTIONS : 4

MEANING : A field has been requested which is not included. The fields are numbered 1 to 40 inclusive for programme F and 1 to 66 inclusive for programme I.

COMPUTER ACTION : The programme will ignore the item in error, and the preceding logical operator if any.

USER ACTION : The item number in error will be printed in the message. Check this against the list of items available.

CLASS H: MESSAGE : D.E.S. NO. WARNING ... YEAR OF UPDATE > COURSE LENGTH

PROGRAMME : R

OPTIONS : 3

MEANING : The year of update given with the date to be added to the record is greater than the expected length of the student's course.

COMPUTER ACTION : The above message is printed, the information is added to the record and the programme continues.

USER ACTION : Check the recorded course length and the year of update given with the date to be added to the record.

CLASS I: MESSAGE : D.E.S. NO. CANNOT BE FOUND ... TRANSACTION
 IGNORED

PROGRAMME : D

MEANING : The D.E.S. No. given with this transaction is
 not known within the specified file.

COMPUTER ACTION : The transaction is ignored and the programme
 continues.

USER ACTION : Check the D.E.S. No. of the transaction that
 was ignored. Check the filename, it may be
 that you are searching in the wrong file.

CLASS J: MESSAGE : D.E.S. NO. TRANSACTION IN ERROR ... TRANSACTION
 IGNORED

PROGRAMME : D

MEANING : The transaction code given with the specified
 D.E.S. No. is not valid.

COMPUTER ACTION : The transaction is ignored and the programme
 continues.

USER ACTION : Check the transaction code of the specified
 file.

CLASS K: MESSAGE : D.E.S. NO. AUTHORITY CODE xxxxx NOT FOUND
 D.E.S. NO. A.LEVEL CODE xxx NOT FOUND

PROGRAMME : D

MEANING : The Authority code or the A'level code recorded
 cannot be found in the file specified.

COMPUTER ACTION : The programme ignores these fields and
 continues.

USER ACTION : The Authority code or the A'level code recorded
 will be printed in the message. Check to see
 if the code is correct and also to see if it is
 included in the list of Authority or A'level
 codes. Check the filename of the file con-
 taining this list.

The lists of Authority/Country and A'level
 codes are given in CODE LISTINGS, Appendix 5.

CLASS L: MESSAGE : D.E.S. NO. HAS NO CORRESPONDING DATA
PROGRAMME : I
OPTIONS : 1, 2, 3 or 4
MEANING : There is no intelligence test data associated with this D.E.S. No.
COMPUTER ACTION : The programme continues with the next record.
USER ACTION : None

CLASS M: MESSAGE : D.E.S. NO. WITHDREW ON xx/xx/xx
D.E.S. NO. LEFT ON xx/xx/xx
D.E.S. NO. AT COLLEGE
PROGRAMME : F and I
OPTIONS : All
MEANING : The student has withdrawn from the college, left the college, or is still at the college.
COMPUTER ACTION : Prints message if requested and continues.
USER ACTION : None, although a print suppression is possible if required (see parameter WRL).

CLASS N: MESSAGE : D.E.S. NO. ADMITTED IN YEAR xxxx
PROGRAMME : R
OPTIONS : 5 or 10
MEANING : The student has previously been admitted to a college and was allocated a D.E.S. No. at that time.
COMPUTER ACTION : The record is ignored and the programme continues.
USER ACTION : None

CLASS O: MESSAGE : D.E.S. NO. TRANSACTION xx COMPLETED
PROGRAMME : D
MEANING : The transaction xx has been completed.
COMPUTER ACTION : The programme continues.
USER ACTION : None

CLASS P: MESSAGE : D.E.S. NO. ANNUAL PROGRESS VECTOR SIZE
EXCEEDED

PROGRAMME : R

OPTIONS : 3

MEANING : The amount of information recorded in the
Annual Progress Vector exceeds 802 characters.

COMPUTER : The information to be added to the Annual
ACTION Progress Vector will be ignored.

USER : None, although a print of the Annual Progress
ACTION Vector should be obtained and information of
less importance removed.

CLASS Q: MESSAGE : D.E.S. NO. ERROR SCHOOL TYPE STORAGE
EXCEEDED
D.E.S. NO. ERROR QUALIFICATION STORAGE
EXCEEDED

PROGRAMME : R

OPTION : 1

MEANING : The Implementation Restriction imposed on
School Type and Qualifications has been
reached.

COMPUTER : Additional School Types and Qualifications
ACTION will be ignored.

USER : None, although it should be ensured that the
ACTION most significant Qualifications are recorded.

CLASS R: MESSAGE : D.E.S. NO. PROCEEDING TO A FOURTH YEAR

PROGRAMME : R

OPTION : 3

MEANING : This student has completed his third year and
is progressing to a fourth or B.Ed. year.

COMPUTER : The course length will be altered to 4.
ACTION

USER : None
ACTION

APPENDIX 5. CODE LISTINGS

- 5.1 Authority/Country Listings
- 5.2 General Codes
- 5.3 Qualification Codes adopted by the College
- 5.4 Subject Codes adopted by the College
- 5.5 A'level Codes and Corresponding Card Columns
- 5.6 Other Relevant Qualification Codes

5.1 AUTHORITY/COUNTRY LISTINGS

| AUTHORITY OR COUNTRY | CODE REQUIRED BY D.E.S. |
|------------------------|-------------------------|
| Alderney | 592 |
| Anglesey | 550 |
| Abu Dhabi | 764 |
| Abyssinia | 648 |
| Aden | 601 |
| Afars/Issas Territory | 749 |
| Afghanistan | 602 |
| Ajman | 764 |
| Albania | 603 |
| Algeria | 604 |
| Andorra | 605 |
| Angola | 794 |
| Anguilla | 736 |
| Antigua | 607 |
| Antilles (Netherlands) | 637 |
| Argentina | 608 |
| Ascension | 735 |
| Australia | 609 |
| Austria | 610 |
| Azores | 728 |
| Barking | 301 |
| Barnet | 302 |
| Barnsley | 451 |
| Barrow-in-Furness | 452 |
| Bath | 453 |
| Bedfordshire | 401 |
| Berkshire | 402 |
| Bexley | 303 |
| Birkenhead | 454 |
| Birmingham | 455 |
| Blackburn | 456 |
| Blackpool | 457 |
| Bolton | 458 |
| Bootle | 459 |
| Bournemouth | 460 |
| Bradford | 461 |
| Breconshire | 551 |
| Brent | 304 |
| Brighton | 462 |
| Bristol | 463 |
| Bromley | 305 |
| Buckinghamshire | 403 |
| Burnley | 464 |
| Burton-on-Trent | 465 |
| Bury | 466 |
| Bahamas | 611 |
| Balearic Is. | 751 |
| Bahrein | 612 |
| Bangladesh | 787 |
| Barbados | 613 |
| Basutoland | 690 |
| Bechuanaland | 618 |
| Belgium | 614 |
| Bermuda | 615 |
| Bhutan | 616 |
| Bolivia | 617 |

AUTHORITY OR COUNTRY

CODE REQUIRED BY D.E.S.

| | |
|--------------------------|-----|
| Borneo North | 739 |
| Borneo South | 673 |
| Botswana | 618 |
| Brazil | 619 |
| Brunei | 620 |
| Bulgaria | 621 |
| Burma | 622 |
| Burundi | 623 |
| Caernarvonshire | 552 |
| Cambridgeshire/Ely | 404 |
| Canterbury | 467 |
| Cardiff | 563 |
| Cardiganshire | 553 |
| Carlisle | 468 |
| Carmarthenshire | 554 |
| Cheshire | 405 |
| Chester | 469 |
| Channel Isles | 591 |
| Cornwall | 406 |
| Coventry | 470 |
| Croydon | 306 |
| Cumberland | 407 |
| Cambodia | 624 |
| Cameroon | 625 |
| Canada | 626 |
| Canary Islands | 751 |
| Cape Verde Is. | 788 |
| Cayman Is. | 789 |
| Central African Republic | 627 |
| Ceylon | 628 |
| Chad | 629 |
| Chile | 630 |
| China, Communist | 631 |
| China, Nationalist | 652 |
| Colombia | 632 |
| Congo Democratic Rep. | 633 |
| Congo (Brazzaville) | 634 |
| Costa Rica | 635 |
| Crete | 661 |
| Cuba | 636 |
| Curacao (Dutch) | 637 |
| Cyprus | 638 |
| Czechoslovakia | 639 |
| Darlington | 472 |
| Denbighshire | 555 |
| Derby | 473 |
| Derbyshire | 408 |
| Devon | 409 |
| Dewsbury | 474 |
| Doncaster | 475 |
| Dorset | 410 |
| Dudley | 476 |
| Durham | 411 |
| Dahomey | 640 |
| Denmark | 641 |

AUTHORITY OR COUNTRY

CODE REQUIRED BY D.E.S.

| | |
|--------------------|-----|
| Dominica | 642 |
| Dominican Republic | 643 |
| Dubia | 764 |
| Ealing | 307 |
| Eastbourne | 477 |
| Enfield | 308 |
| Essex | 412 |
| Exeter | 479 |
| Ecuador | 645 |
| Egypt | 768 |
| Eire | 676 |
| El Salvador | 646 |
| Ellice Is. | 660 |
| Equatorial Guinea | 790 |
| Eritrea | 648 |
| Estonia | 772 |
| Ethiopia | 648 |
| Flintshire | 556 |
| Falkland Is. | 649 |
| Fiji | 650 |
| Finland | 651 |
| Formosa | 652 |
| France | 653 |
| French Guiana | 791 |
| French West Indies | 792 |
| Fujairah | 764 |
| Gateshead | 480 |
| Glamorgan | 557 |
| Gloucester | 481 |
| Gloucestershire | 413 |
| Great Yarmouth | 482 |
| Grimsby | 483 |
| Guernsey | 593 |
| Gaboon | 654 |
| Gambia | 655 |
| Germany, West | 656 |
| Germany, East | 657 |
| Ghana | 658 |
| Gibraltar | 659 |
| Gilbert/Ellis Is. | 660 |
| Greece | 661 |
| Greenland | 641 |
| Grenada | 662 |
| Guadeloupe | 792 |
| Guatamala | 663 |
| Guiana (British) | 665 |
| Guiana (Dutch) | 753 |
| Guiana (French) | 791 |
| Guinea | 664 |
| Guyana | 665 |
| Halifax | 484 |
| Hampshire | 414 |
| Haringey | 309 |

AUTHORITY OR COUNTRY

CODE REQUIRED BY D.F.S.

| | |
|----------------------|-----|
| Harrow | 310 |
| Hartlepool | 533 |
| Hastings | 485 |
| Havering | 311 |
| Herefordshire | 415 |
| Hertfordshire | 416 |
| Hillingdon | 312 |
| Hounslow | 313 |
| Huddersfield | 486 |
| Huntingdon and Peter | 417 |
| Haiti | 666 |
| Holland | 710 |
| Honduras | 667 |
| Honduras, British | 668 |
| Hong Kong | 669 |
| Hungary | 670 |
| I.L.E.A. | 427 |
| Ipswich | 487 |
| Isle of Man | 595 |
| Isle of Wight | 419 |
| Isles of Scilly | 420 |
| Iceland | 671 |
| India | 672 |
| Indonesia | 673 |
| Iran | 674 |
| Iraq | 675 |
| Ireland, Republic | 676 |
| Israel | 677 |
| Italy | 678 |
| Ivory Coast | 679 |
| Jersey | 594 |
| Jamaica | 680 |
| Japan | 681 |
| Jordan | 682 |
| Kent | 421 |
| Kingston upon Hull | 488 |
| Kingston-on-Thames | 314 |
| Kenya | 683 |
| Khmer Rep. | 624 |
| Korea, South | 684 |
| Korea, North | 685 |
| Kuwait | 686 |
| Lancashire | 422 |
| Leeds | 489 |
| Leicester | 490 |
| Leicestershire | 423 |
| Lincoln | 491 |
| Lincs. Holland | 424 |
| Lincs. Kesteven | 425 |
| Lincs. Lindsey | 426 |
| Liverpool | 492 |
| Luton | 531 |
| Laos | 687 |

AUTHORITY OR COUNTRY

CODE REQUIRED BY D.E.S.

| | |
|----------------------|-----|
| Latvia | 772 |
| Lebanon | 688 |
| Lesotho | 690 |
| Liberia | 691 |
| Libya | 692 |
| Liechtenstein | 756 |
| Lithuania | 772 |
| Luxembourg | 693 |
| Manchester | 493 |
| Merioneth | 558 |
| Merthyr Tydfil | 564 |
| Merton | 315 |
| Middlesbrough | 494 |
| Monmouthshire | 559 |
| Montgomeryshire | 560 |
| Macao | 694 |
| Madagascar | 695 |
| Madeira | 728 |
| Malagasy | 695 |
| Malawi | 696 |
| Malaya | 697 |
| Maldives Is. | 793 |
| Mali | 699 |
| Malta | 700 |
| Martinique | 792 |
| Mauritania | 701 |
| Mauritius | 702 |
| Mexico | 703 |
| Monaco | 653 |
| Mongolia, Outer | 704 |
| Montserrat | 705 |
| Morocco | 706 |
| Mozambique | 707 |
| Muscat/Oman | 708 |
| Newcastle | 495 |
| Newham | 316 |
| Newport | 565 |
| Norfolk | 429 |
| Northampton | 496 |
| Northamptonshire | 430 |
| Northern Ireland | 099 |
| Northumberland | 431 |
| Norwich | 497 |
| Nottingham | 498 |
| Nottinghamshire | 432 |
| Namibia | 798 |
| Nepal | 709 |
| Netherlands | 710 |
| Netherlands Antilles | 637 |
| New Caledonia | 711 |
| New Guinea | 712 |
| New Hebrides | 713 |
| New Zealand | 714 |
| Nicaragua | 715 |
| Niger | 716 |

AUTHORITY OR COUNTRY

CODE REQUIRED BY D.E.S.

| | |
|------------------------|-----|
| Nigeria | 717 |
| Norway | 718 |
| Not Known | 782 |
| Nyasaland | 696 |
| Oldham | 499 |
| Oxford | 500 |
| Oxfordshire | 433 |
| Pembrokeshire | 561 |
| Plymouth | 501 |
| Portsmouth | 502 |
| Preston | 503 |
| Pakistan | 721 |
| Panama | 722 |
| Papua | 723 |
| Paraguay | 724 |
| Persia | 674 |
| Peru | 725 |
| Philippines | 726 |
| Poland | 727 |
| Portugal | 728 |
| Portuguese East Africa | 707 |
| Portuguese West Africa | 794 |
| Portuguese Guinea | 794 |
| Portuguese Timor | 786 |
| Puerto Rico | 730 |
| Quatar | 731 |
| Radnorshire | 562 |
| Redbridge | 317 |
| Richmond-upon-Thames | 318 |
| Reading | 504 |
| Rochdale | 505 |
| Rotherham | 506 |
| Rutland | 435 |
| Ras Al Khaimah | 764 |
| Reunion | 795 |
| Rhodesia, Norhern | 781 |
| Rhodesia | 732 |
| Rumania | 733 |
| Rwanda | 734 |
| Salford | 508 |
| Salop | 436 |
| Sheffield | 509 |
| Solihull | 530 |
| Somerset | 437 |
| Southampton | 511 |
| Southend-on-Sea | 512 |
| Southport | 513 |
| South Shields | 514 |
| Staffordshire | 438 |
| St. Helens | 507 |
| Stockport | 515 |
| Stoke-on-Trent | 516 |

AUTHORITY OR COUNTRY

CODE REQUIRED BY D.E.S.

| | |
|-----------------------|-----|
| Suffolk, E | 439 |
| Suffolk, W | 440 |
| Sunderland | 517 |
| Surrey | 441 |
| Sutton | 319 |
| Sussex, E | 442 |
| Sussex, W | 443 |
| Swansea | 566 |
| St. Helena | 735 |
| St. Kitts-Nevis | 736 |
| St. Lucia | 737 |
| St. Tome and Principe | 794 |
| St. Vincent | 738 |
| Sabah | 739 |
| Salvador | 646 |
| Samoa (U.S.) | 796 |
| San Marino | 678 |
| Sarawak | 742 |
| Saudi Arabia | 743 |
| Scotland | 299 |
| Senegal | 785 |
| Seychelles | 744 |
| Sharjah | 764 |
| Siam | 760 |
| Sierra Leone | 745 |
| Sikkim | 797 |
| Singapore | 746 |
| Solomon Is. | 747 |
| Somali Republic | 748 |
| Somaliland (French) | 749 |
| South Africa | 750 |
| South West Africa | 798 |
| South Yemen Rep. | 601 |
| Spain | 751 |
| Stateless | 783 |
| Sudan | 752 |
| Surinam | 753 |
| Swaziland | 754 |
| Sweden | 755 |
| Switzerland | 756 |
| Syrian Arab Rep. | 757 |
| Teesside | 535 |
| Torbay | 534 |
| Tynemouth | 518 |
| Taiwan | 652 |
| Tanganyika | 759 |
| Tangiers | 706 |
| Tanzania | 759 |
| Tchad | 629 |
| Thailand | 760 |
| Tibet | 761 |
| Togo | 762 |
| Tonga | 784 |
| Trinidad and Tobago | 763 |
| Tristan Da Cunha | 735 |
| Trucial States | 764 |

AUTHORITY OR COUNTRY

CODE REQUIRED BY D.E.S.

| | |
|----------------------|-----|
| Tunisia | 765 |
| Turkey | 766 |
| Turks and Caicos Is. | 799 |
| Uganda | 767 |
| Ummalquaiwain | 764 |
| United Arab Republic | 768 |
| Upper Volta | 769 |
| Uruguay | 770 |
| U.S.A. | 771 |
| U.S.S.R. | 772 |
| Vatican City | 678 |
| Venezuela | 773 |
| Vietnam, South | 774 |
| Vietnam, North | 775 |
| Virgin Is. (British) | 776 |
| Virgin Is. (U.S.) | 800 |
| Wakefield | 519 |
| Wallasey | 520 |
| Walsall | 521 |
| Waltham Forest | 320 |
| Warley | 532 |
| Warrington | 522 |
| Warwickshire | 444 |
| West Bromwich | 523 |
| Westmorland | 445 |
| Wigan | 526 |
| Wiltshire | 446 |
| Wolverhampton | 527 |
| Worcester | 528 |
| Worcestershire | 447 |
| West Indies | 777 |
| Western Samoa | 741 |
| Windward Is. | 778 |
| York | 529 |
| Yorks. E Riding | 448 |
| Yorks. N Riding | 449 |
| Yorks. W Riding | 450 |
| Yemen | 779 |
| Yugoslavia | 780 |
| Zaire | 633 |
| Zambia | 781 |
| Zanzibar | 759 |

5.2 GENERAL CODES

MARITAL STATUS

- 1 Single
- 2 Married
- 3 Divorced/Wid

GEOGRAPHICAL REGION (not coded prior to 1972)

- A Scotland and Northern Ireland
- B Northern
- C Yorkshire and Humberside
- D North West
- E East Midland
- F West Midland
- G Wales and Monmouth
- H South West
- I East Anglia
- J South East
- K Other/Abroad

SETTLEMENT

- 1 Roadside or Hamlet, i.e. less than 150 people
- 2 Village or Small Town, i.e. 150 to 2,500 people
- 3 Town, i.e. 2,500 to 10,000 people
- 4 Large Town, i.e. 10,000 to 500,000 people
- 5 Metropolis, i.e. over 500,000 people
- 6 N/A

SETTLEMENT (prior to 1972)

- 1 Metropolitan (large city centre)
- 2 Suburban (outskirts of large city)
- 3 Rural Urban (small town or village)
- 4 Rural

OCCUPATION IF OVER 25

- Ø Other
- 1 Teaching or Youth Service
- 2 Central or Local Government
- 3 H.M. Forces
- 4 Police
- 5 Nursing
- 6 Other Medical or Welfare Service
- 7 Banking/Insurance/Accountancy
- 8 Commerce
- 9 Industry

STUDENT/PARENT/GUARDIAN OCCUPATION

- 1 Higher Administrative Professional and Managerial
- 2 Farmers, Intermediate Administrative Professional and Managerial
- 3 Routine non-manual and Service. Manual skilled
- 4 Semi-skilled Workers
- 5 Unskilled Workers

STUDENT/PARENT/GUARDIAN OCCUPATION (prior to 1972)

- 1 Professional and High Administrative
- 2 Managerial and Executive
- 3 Non-manual, Higher Grade
- 4 Non-manual, Lower Grade
- 5 Skilled Manual
- 6 Semi-skilled Manual

RELIGION

- 1 C. of E.
- 2 R.C.
- 3 Nonconformist
- 4 Other Religion
- 5 Humanist/Agnostic/Atheist

RELIGION (prior to 1972)

- 1 C. of E.
- 2 R.C.
- 3 Nonconformist
- 4 Jewish
- 5 Agnostic/Atheist
- 6 Humanist/Other

SCHOOL TYPE

- 1 Independent or Direct Grant School Mixed
- 2 Independent or Direct Grant School Single Sex
- 3 Grammar Mixed
- 4 Grammar Single Sex
- 5 Comprehensive Mixed
- 6 Comprehensive Single Sex
- 7 Sec. Modern School Mixed
- 8 Sec. Modern School Single Sex
- 9 Coll. of Further Education/Technical Coll.

QUALIFICATION TYPE

- O G.C.E. O'levels
- A G.C.E. A'levels
- S G.C.E. S'levels
- ONC Ordinary National Certificate
- HNC Higher National Certificate
- OND Ordinary National Diploma
- HND Higher National Diploma
- CSE Certificate of Secondary Education
- SCC School Certificate
- SCH Scottish Highers/Lowers
- NRC Northern Counties
- RSA Royal Society of Arts
- C&G City and Guilds
- E Extra Qualifications

SUBSEQUENT CAREERS (coded A to H prior to 1972)

- 1 School, F.E., Coll. of Ed. (not indep.) E & W
- 2 School, F.E., Coll. of Ed. (not indep.) N & S
- 3 Indep. School, U.K.
- 4 Any other tchg., U.K.
- 5 Any other tchg., abroad
- 6 Further t.t.
- 7 Non-teaching
- 8 Other course

WITHDRAWAL CODES

- 1 Unsatisfactory Progress
- 2 Transfer to another training establishment
- 3 Health
- 4 Death
- 5 Intercalation
- 9 Other

5.3 QUALIFICATION CODES ADOPTED BY THE COLLEGE

| | |
|--------------------------|-----|
| Art | Ø94 |
| Art & Craft | 1Ø4 |
| Metalwork | Ø88 |
| Woodwork | Ø89 |
| Geography | Ø52 |
| Music | Ø92 |
| R.K. (R.S. Divinity) | Ø98 |
| Drama | Ø57 |
| Film & T.V. | 1Ø9 |
| | |
| French | Ø41 |
| German | Ø42 |
| Greek | Ø3Ø |
| Italian | Ø44 |
| Latin | Ø31 |
| Russian | Ø45 |
| Shona | 1ØØ |
| Spanish | Ø43 |
| Arabic | Ø33 |
| Welsh | Ø46 |
| English Lang. | Ø61 |
| English Lit. | Ø6Ø |
| Use of English | Ø62 |
| English Oral | Ø63 |
| Entr. Test in English | Ø64 |
| General English | Ø65 |
| | |
| History | Ø51 |
| History of Art | ØØ5 |
| Ancient History | Ø53 |
| Modern History | Ø56 |
| Econ. & Soc. History | Ø49 |
| British Const. | Ø5Ø |
| British Econ. Organ. | ØØ1 |
| General Classics | Ø29 |
| Greek & Roman Lit. | Ø32 |
| French Lit. | Ø4Ø |
| | |
| General Science | Ø27 |
| Physical & Biol. Science | Ø48 |
| Biology | Ø23 |
| Chemistry | Ø22 |
| Physics | Ø21 |
| Physical Science | Ø47 |
| Geology | Ø25 |
| Zoology | Ø26 |
| Physics with Chemistry | Ø2Ø |
| Rural Science | Ø83 |
| Human Biol. & Hygiene | Ø24 |
| Anatomy & Physiology | ØØ6 |
| Hist. & Phil. of Science | ØØ7 |
| Build. & Engin. Science | Ø97 |

| | |
|-------------------------|-----|
| Arithmetic | Ø1Ø |
| Mathematics | Ø11 |
| Maths (Pure & Applied) | Ø12 |
| Additional Maths | Ø13 |
| Elementary Maths | Ø14 |
| Maths for Science | Ø15 |
| Maths with Mechanics | Ø16 |
| Mathematics S.M.P. | Ø17 |
| Engineering Drawing | Ø87 |
| Technical Drawing | Ø86 |
| Workshop Theory & Prac. | Ø9Ø |
| Mechanics | Ø82 |
| Applied Mechanics | Ø38 |
| Surveying & Bldg. | Ø37 |
| Economics | Ø91 |
| Statistics | Ø34 |
| Accounts | Ø55 |
| Commerce | Ø54 |
| Civics | ØØ8 |
| Law | ØØ4 |
| Psychology | Ø58 |
| Sociology | Ø59 |
| Philosophy | Ø96 |
| Physical Education | ØØ2 |
| Youth Work | 1Ø2 |
| Dance Music & Movement | 1Ø3 |
| General Studies | Ø99 |
| Contemporary Studies | Ø73 |
| Engineering | Ø39 |
| Catering | Ø66 |
| Domestic Science | Ø67 |
| Needlework | 1Ø1 |
| Education | Ø93 |

5.4 SUBJECT CODES ADOPTED BY THE COLLEGE

| | |
|--------------------|-----|
| Art & Craft | 104 |
| Drama | 057 |
| English | 061 |
| Film & T.V. | 109 |
| Geography | 052 |
| History | 051 |
| Mathematics | 011 |
| Music | 092 |
| Physical Education | 002 |
| Religious Studies | 098 |
| All Sciences | 048 |
| French | 041 |

5.5 A'LEVEL CODES AND CORRESPONDING CARD COLUMNS

The grades of A'level passes are recorded in specified card columns on Card 3 of 3.1 CARD OUTPUT ADMISSIONS, Appendix 3. The College codes corresponding to each of the card columns are given below:

Columns

| | |
|----|--|
| 30 | English Literature 060 English Literature |
| 31 | Welsh Language 046 Welsh |
| 32 | Latin 031 Latin |
| 33 | Greek 030 Greek |
| 34 | French 041 French |
| 35 | German 042 German |
| 36 | Italian 044 Italian |
| 37 | Spanish 043 Spanish |
| 38 | Russian 045 Russian |
| 39 | Other Modern Languages (not elsewhere specified) 033 Arabic 100 Shona |
| 40 | History 051 History |
| 41 | Ancient History 053 Ancient History |
| 42 | Religious Knowledge 098 R.K. (R.S. Divinity) |
| 43 | Art 094 Art |
| 44 | Art and Craft (excluding Needlework) 104 Art and Craft |
| 45 | Music 092 Music |
| 46 | Other Art Subjects 004 Law 005 History of Art 029 General Classics 061 English Language 032 Greek and Roman Literature 040 French Literature 056 Modern History 007 History and Philos. of Science 008 Civics 055 Accounts 054 Commerce 073 Contemporary Studies 096 Philosophy |

Columns

- 47 Pure Mathematics (including double subjects)
No College code equivalent
- 48 Applied Mathematics (including double subject/statistics)
No College code equivalent
- 49 Pure and Applied Mathematics (single subject)
Ø12 Maths (Pure and Applied)
- 50 Additional Mathematics (including Higher/Further)
Ø13 Additional Maths
- 51 Mathematics (not elsewhere specified)
Ø11 Mathematics
Ø14 Elementary Maths
Ø15 Maths for Science
Ø16 Maths with Mechanics
Ø17 Mathematics S.M.P.
Ø1Ø Arithmetic
- 52 Physics
Ø21 Physics
- 53 Chemistry
Ø22 Chemistry
- 54 Botany
No College code equivalent
- 55 Zoology
Ø26 Zoology
- 56 Biology
Ø23 Biology
- 57 Geology
Ø25 Geology
- 58 Technical Drawing
Ø86 Technical Drawing
- 59 Metalwork
Ø88 Metalwork
- 60 Woodwork
Ø89 Woodwork
- 61 Other Science or Technical Subjects
Ø27 General Science
Ø47 Physical Science
Ø48 Physical and Biol. Science
Ø2Ø Physics with Chemistry
Ø24 Human Biol. and Hygiene
ØØ6 Anatomy and Physiology
Ø83 Rural Science
Ø82 Mechanics
Ø97 Building and Engineering Science
Ø9Ø Workshop Theory and Prac.
Ø34 Statistics
Ø37 Surveying and Building
Ø38 Applied Mechanics
Ø58 Psychology
Ø39 Engineering
Ø67 Domestic Science
Ø87 Engineering Drawing
- 62 English Economic History
Ø49 Economic and Social History
- 63 British Constitution
Ø5Ø British Constitution
- 64 Economics
Ø91 Economics



Columns

- 65 Geography
 - Ø52 Geography
- 66 General Studies
 - Ø99 General Studies
- 67 Domestic Subjects (excluding Needlework)
 - Ø67 Domestic Science
- 68 Needlework
 - 1Ø1 Needlework
- 69 Other Social Science or Vocational Subjects
 - Ø59 Sociology
 - 1Ø2 Youth Work
 - 1Ø3 Dance, Music and Movement
 - ØØ2 Physical Education
 - Ø66 Catering
 - Ø93 Education

5.6 OTHER RELEVANT QUALIFICATION CODES

The following list provides the 4 character codes required by D.E.S. when a student is admitted to the College with 'other' relevant qualifications. The list is abbreviated giving only the more common codes, but a full list can be obtained from the College Records Office.

H.N.C. (Higher National Certificate)

| | |
|-------------------------------|------|
| Building | Ø56Ø |
| Commerce | Ø561 |
| Chemistry (including applied) | Ø562 |
| Physics applied | Ø563 |
| Aeronautical Engineering | Ø564 |
| Chemical Engineering | Ø565 |
| Civil Engineering | Ø566 |
| Electrical Engineering | Ø567 |
| Mechanical Engineering | Ø568 |
| Production Engineering | Ø569 |
| Metallurgy | Ø57Ø |
| Mining | Ø571 |
| Naval Architecture | Ø572 |
| Textiles | Ø573 |

H.N.D. (Higher National Diploma)

| | |
|--------------------------|------|
| Building | Ø574 |
| Chemistry | Ø575 |
| Chemistry applied | Ø576 |
| Aeronautical Engineering | Ø577 |
| Electrical Engineering | Ø578 |
| Mechanical Engineering | Ø579 |
| Production Engineering | Ø58Ø |
| Mining | Ø581 |

O.N.C. (Ordinary National Certificate)

| | |
|-------------------------------|------|
| Building | Ø686 |
| Commerce | Ø687 |
| Chemistry (including applied) | Ø688 |
| Physics applied | Ø689 |
| Electrical Engineering | Ø69Ø |
| Mechanical Engineering | Ø691 |
| Metallurgy | Ø692 |
| Mining | Ø693 |
| Naval Architecture | Ø694 |
| Textiles | Ø695 |

O.N.D. (Ordinary National Diploma)

| | |
|--|------|
| Building | Ø696 |
| Electrical Engineering | Ø697 |
| Mechanical Engineering | Ø698 |
| Oxford University Secondary Art Teachers Certificate | Ø699 |

P.C.T.

| | |
|-----------------------------------|------|
| Pitman's Certificate for Teachers | Ø7ØØ |
|-----------------------------------|------|

Overseas Qualifications

| | |
|--|------|
| Art | Ø816 |
| Chemistry | Ø858 |
| Domestic Science | Ø762 |
| Education | Ø782 |
| English Language | Ø783 |
| History and/or Political Science | Ø797 |
| Language other than English | Ø813 |
| Law | Ø845 |
| Mechanical and/or Electrical Engineering | Ø781 |
| Medicine | Ø857 |
| Metallurgy | Ø814 |
| Music | Ø8Ø3 |
| Physical Education | Ø78Ø |
| Religious Knowledge | Ø798 |
| Teaching | Ø856 |

C&G (City and Guilds)

| | |
|---|------|
| Advanced Cookery for Hotel and Restaurants 152 | Ø149 |
| Advanced Dental Technology 118 | Ø15Ø |
| Advanced Dress 234 | Ø151 |
| Advanced Domestic Cookery 244 | Ø152 |
| Advanced Hand Embroidery 232 | Ø153 |
| Advanced Home Upholstery and Soft Furnishings 242 | Ø154 |
| Advanced Hand Loom Weaving 248 | Ø155 |
| Advanced Ladies' Tailoring 24Ø | Ø156 |
| Advanced Millinery 236 | Ø157 |
| Advanced Needlework 238 | Ø158 |
| Agricultural Engineering Fitters' Work 261 | Ø159 |
| Agricultural Mechanics' Work 26Ø | Ø16Ø |
| Aircraft Electrical Practice 175 | Ø161 |
| Aircraft Maintenance Airframe 174 283 | Ø162 |
| Aircraft Maintenance Electrical 284 | Ø163 |
| Aircraft Maintenance Instruments 285 | Ø164 |
| Aircraft Maintenance Power Plant 173 282 | Ø165 |
| Aircraft Production Airframe 172 281 | Ø166 |
| Aircraft Production Power Plant 171 28Ø | Ø167 |
| Animal Husbandry 266 269 | Ø168 |
| Applications of Science in Printing 224 | Ø169 |
| Appreciation of Colour and Design 44 | Ø17Ø |
| Appreciation of Design and Colour in Printing 223 | Ø171 |

C&G (continued)

| | |
|--|------|
| Basic Craft Course in Binding and Warehouse 216 | Ø172 |
| Blacksmith and Mechanics Work 78 | Ø173 |
| Boiler-House Practice 76 | Ø174 |
| Boilermakers' Work 65 | Ø175 |
| Boiler Operators' Certificate 75 | Ø176 |
| Boot and Shoe Manufacture 137 | Ø177 |
| Boot and Shoe Repairing 139 | Ø178 |
| Breadmaking and Flour Confectionery 156 | Ø179 |
| Brickwork 82 | Ø180 |
| Builders' Quantities 89 | Ø181 |
| | |
| Carpentry and Joinery 80 | Ø182 |
| Catering Trades' Basic 150 | Ø183 |
| Certificate in Retail Management Principles 136 | Ø184 |
| Chemical Plant Operation 24 | Ø185 |
| Chemistry as applied to the Textile Industry 43 | Ø186 |
| Coal Mining Advanced Cert. 191 | Ø187 |
| Coal Mining Certificate 25 | Ø188 |
| Cocoa, Chocolate and Sugar Confectionery Man. 158 | Ø189 |
| Colliery Electricians' Advanced Certificate 190 | Ø190 |
| Colliery Electricians' Certificate 27 | Ø191 |
| Colliery Mechanics' Advanced Certificate 189 | Ø192 |
| Colliery Mechanics' Certificate 26 | Ø193 |
| Combustion Engineering 77 | Ø194 |
| Compositors' Work 201 | Ø195 |
| Concrete Practice 93 | Ø196 |
| Concrete Technology 110 | Ø197 |
| Cookery for Hotels and Catering Establishments 151 | Ø198 |
| Cotton Spinning 32 | Ø199 |
| Cotton Weaving 34 | Ø200 |
| Crop Husbandry 265 268 | Ø201 |
| | |
| Dental Technicians' Course 117 | Ø202 |
| Design and Decoration of Flour Confectionery 157 | Ø203 |
| Domestic Cookery 243 | Ø204 |
| Domestic Subjects (F.E. Teacher's Certificate 164 | Ø205 |
| Dress 233 | Ø206 |
| Dress Manufacture 126 | Ø207 |
| Dyeing of Textiles 45 | Ø208 |
| | |
| Electrical Engineering Practice 52 | Ø209 |
| Electrical Fitters' Course 58 | Ø210 |
| Electrical Technicians' Course 57 | Ø211 |
| Electrical Installation Work 51 | Ø212 |
| Electronics - Craft Practice (Aircraft) 286 | Ø213 |
| Electronics Servicing 47 | Ø214 |
| Electrotyping and Stereotyping 209 | Ø215 |
| Engineering Planning, Estimating and Costing 64 | Ø216 |
| | |
| Fabrication of Steelwork 176 | Ø217 |
| Farm Machinery 267 | Ø218 |
| Farm Machinery Operation and Care 270 | Ø219 |
| Farm Maintenance and Repair 272 | Ø220 |
| Farm Organisation and Management 278 | Ø221 |
| Farm Records and Accounts 271 | Ø222 |
| Final Course in General Bookbinding 217 | Ø223 |

C&G (continued)

| | |
|---|------|
| Final Course in Printing Warehouse Practice 219 | Ø224 |
| Final Course in Publishers' Edition Binding 218 | Ø225 |
| Flax Spinning 35 | Ø226 |
| Flour Milling 112 | Ø227 |
| Framework and Shuttering for Concrete Construction 95 | Ø228 |
| Foundry Practice 62 | Ø229 |
| Fuel Technology 5 | Ø230 |
| Furnace Brickwork 97 | Ø231 |
| Furniture Industry 103 | Ø232 |
| Gas Fitting 13 | Ø233 |
| Gas Technology (Manufacture) Gas Utilisation 12 | Ø234 |
| General Foremanship (Building Industry) 98 | Ø235 |
| General Survey of Printing Industry 221 | Ø236 |
| Goldsmiths' and Silversmiths' Work 130 | Ø237 |
| Hairdressing 124 | Ø238 |
| Hand Embroidery 231 | Ø239 |
| Hand Loom Weaving 247 | Ø240 |
| Handrailing and Stair Construction 94 | Ø241 |
| Heating and Ventilating Technicians' Course 181 | Ø242 |
| Heating and Ventilating Engineering Fitters' Course 255 | Ø243 |
| Heating and Ventilating Fitter/Welders' Course (Oxy-acetylene) 236 | Ø244 |
| Heating and Ventilating Engineering Fitter/Welders' Course (Metal-Arc) | Ø245 |
| Heating and Ventilating Engineering Draughtsmen's Course 259 | Ø246 |
| Home Upholstery and Soft Furnishings 241 | Ø247 |
| Home Management 245 | Ø248 |
| Illuminating Engineering 113 | Ø249 |
| Industrial Organisation 42 | Ø250 |
| Industrial Radiography 56 | Ø251 |
| Instrument Maintenance 79 | Ø252 |
| Instrument Making 185 | Ø253 |
| Iron and Steel Operatives' Course 15 | Ø254 |
| Iron Ore Operatives' Course 196 | Ø255 |
| Iron Ore Quarrying Advanced Certificate 198 | Ø256 |
| Iron Ore Quarrying Certificate 197 | Ø257 |
| Jewellery 132 | Ø258 |
| Jute Spinning 38 | Ø259 |
| Jute Weaving 39 | Ø260 |
| Ladies' Tailoring 239 | Ø261 |
| Laundry Technology 115 | Ø262 |
| Leather Goods Manufacture 129 | Ø263 |
| Leather Manufacture Dyeing and Finishing 18 | Ø264 |
| Letterpress Machine Printing 205 | Ø265 |
| Letterpress Rotary Machine Printing 207 | Ø266 |
| Light Electrical Engineering Inspection 59 | Ø267 |
| Line Composition 202 | Ø268 |
| Linen Weaving 36 | Ø269 |
| Lithographic Artists' Work 213 | Ø270 |
| Lithographic Printing 215 | Ø271 |

C&G (continued)

| | |
|--|------|
| Machine Shop Engineering 63 | Ø272 |
| Manufacture of Hosiery and Knitted Goods 4Ø | Ø273 |
| Manufacture of Silk and Man-made Fibres 37 | Ø274 |
| Masonry 83 | Ø275 |
| Mastic Asphalt Work 92 | Ø276 |
| Mechanical Engineering Craft Practice 193 | Ø277 |
| Mechanical Engineering Drawing 194 | Ø278 |
| Mechanical Engineering Design 6Ø | Ø279 |
| Mechanical Engineering Inspection 7Ø | Ø28Ø |
| Metal Finishing 17 | Ø281 |
| Metallurgy 14 | Ø282 |
| Milk Pasteurisation and Distribution 159 | Ø283 |
| Milk Processing and Control 16Ø | Ø284 |
| Mill Engineering and Services 41 | Ø285 |
| Millinery 235 | Ø286 |
| 'Monotype' Composition 2Ø3 | Ø288 |
| Motor Body Work 69 | Ø289 |
| Motor Vehicle Electricians' Work 169 | Ø29Ø |
| Motor Vehicle Mechanics' Work 168 | Ø291 |
| Motor Vehicle Technicians' Work 17Ø | Ø292 |
| National Retail Distribution Certificate 133 | Ø293 |
| Needlework 237 | Ø294 |
| Painters' and Decorators' Work 85 | Ø295 |
| Paint Technology 9 | Ø296 |
| Papermaking Practice 165 | Ø297 |
| Paper Technology 1 | Ø298 |
| Patternmaking 61 | Ø299 |
| Petroleum and Petroleum Products 7 | Ø3ØØ |
| Photography | Ø3Ø1 |
| Photo-engraving 21Ø | Ø3Ø2 |
| Photogravure 211 | Ø3Ø3 |
| Photolithography 212 | Ø3Ø4 |
| Photogravure Machine Printing 2Ø6 | Ø3Ø5 |
| Plain Cotton Weaving 33 | Ø3Ø6 |
| Plant Engineering 187 | Ø3Ø7 |
| Plasterers' Work 84 | Ø3Ø8 |
| Plumbers' Work 86 | Ø3Ø9 |
| Power Plant Operation 167 | Ø31Ø |
| Preliminary Trade Cookery 147 | Ø311 |
| Press Tool Making 186 | Ø312 |
| Printers' Costing 225 | Ø313 |
| Printers' Estimating 226 | Ø314 |
| Printing Administration 227 | Ø315 |
| Printing Ink Technicians' Advanced Certificate 251 | Ø316 |
| Printing Ink Technicians' Certificate 25Ø | Ø317 |
| Radio Amateurs' Examination 55 | Ø318 |
| Radio and Television Servicing 48 | Ø319 |
| Railway Carriage and Wagon Construction 67 | Ø32Ø |
| Refrigeration Practice 72 | Ø321 |
| Retail Distributive Trades Course 135 | Ø322 |
| Retail Trades Junior Certificate 134 | Ø323 |
| Roof slating, Tiling and Cement Work 96 | Ø324 |
| Rubber Workshop Practice 12Ø | Ø325 |

C&G (continued)

| | |
|---|------|
| Sand, Gravel and Quarrying Advanced Certificate 254 | Ø326 |
| Sand, Gravel and Quarrying Certificate 253 | Ø327 |
| Sand, Gravel and Quarrying Operative Certificate 252 | Ø328 |
| Sanitary and Domestic Engineering in relation to Plumbers' Work 88 | Ø329 |
| Science Laboratory Technicians' Certificate 119 | Ø330 |
| Science and Technology of Refrigeration 73 | Ø331 |
| Sheet Metal Work 66 | Ø332 |
| Ship Joinery 183 | Ø333 |
| Shipbuilding 182 | Ø334 |
| Ship Plumbing and Marine Sanitary Engineering 87 | Ø335 |
| Silversmiths' Work - Allied Crafts 131 | Ø336 |
| Solid Fuel Production, Distribution and Utilisation 188 | Ø337 |
| Steam Turbine Plant Operation 192 | Ø338 |
| Steam Utilisation Practice 29 | Ø339 |
| Street Masons' and Paviours' Work 99 | Ø340 |
| Structural Detailing 288 | Ø341 |
| Structural Engineering 91 | Ø342 |
| Supplementary Studies in Telecommunication and Electronics 300 | Ø343 |
| Tailors' Cutting and Tailoring 116 | Ø344 |
| Teacher's Certificate in Dressmaking | Ø757 |
| Teacher's Certificate in Handicraft. First/or Second Handicraft Examination 162 | Ø345 |
| Technical Authorship 229 | Ø346 |
| Technical Illustration 228 | Ø347 |
| Technical Processes of Printing 222 | Ø348 |
| Technical Teacher's Certificate 163 | Ø349 |
| Technology of Plastics 11 | Ø350 |
| Telecommunication Technicians' Course 49 | Ø351 |
| Typographic Design 200 | Ø352 |
| Welding 74 | Ø353 |
| Welding in relation to Plumbers' Work 90 | Ø354 |
| Wholesale Textile Distribution 122 | Ø355 |
| Woodcutting Machinists' Work 81 | Ø356 |
| Woollen and Worsted Manufacture 30 | Ø357 |
| Work Study 195 | Ø358 |
| Yacht and Boat Building 184 | Ø359 |
| Automobile Engineering Practice | Ø759 |
| Boot and Shoe Manufacture 137 | Ø360 |
| Breadmaking and Flour Confectionery 156 | Ø361 |
| Carpentry and Joinery 80 | Ø362 |
| Clothing Technology 128 | Ø363 |
| Dyeing of Textiles 45 | Ø364 |
| Fabrication of Steelwork 176 | Ø365 |
| Flax Spinning 35 | Ø366 |
| Jute Weaving 39 | Ø367 |
| Laundry Technology 115 | Ø368 |
| Linen Weaving 36 | Ø369 |
| Machine Shop Engineering | Ø756 |
| Manufacture of Silk and Man-made Fibres 37 | Ø370 |
| Milk Processing and Control 160 | Ø371 |
| Paint Technology 9 | Ø372 |
| Plasterers' Work 84 | Ø373 |

C&G (continued)

Plumbers' Work 86
Sheet Metal Work 66
Textile Technology 35-36
Typographic Design 200
Woodcutting Machinists' Work 81
Woollen and Worsted Manufacture 80

0374
0375
0376
0377
0378
0379

Appendix 3

BCRS...Bede College Record System

Programme Documentation

(Part 1)

This Appendix contains Part 1 of the BCRS programme documentation. It provides an introduction to the development of the system and to the BCRS programmes. Part 2 containing source programme and data listings is provided in a supplementary document to this thesis.

BCRS BEDE COLLEGE RECORD SYSTEM

PROGRAMME DOCUMENTATION

(PART 1)

ABSTRACT

The Data Management System BCRS records and maintains student records in data base files.

The system consists of a suite of PL/1 (Programming Language 1) programmes designed to run on the NUMAC IBM 360/67 computer under MTS (Michigan Terminal System) in batch mode.

This report together with 'BCRS BEDE COLLEGE RECORD SYSTEM, PROGRAMME DOCUMENTATION (PART 2)' describes the programmes and provides listings of their source code, the input expected and the output provided.

PROGRAMME DOCUMENTATION (PART 1)

C O N T E N T S

| | Part | Page |
|---|------|------|
| 1. INTRODUCTION | 1 | 1 |
| 2. PROGRAMME VARIABLES | | |
| 2.1 The RECORD Structure | 1 | 5 |
| 2.2 Programme Variables | 1 | 8 |
| 2.3 Programme Files | 1 | 12 |
| 3. PROGRAMME R | | |
| 3.1 Programme Introduction | 1 | 13 |
| 3.2 Programme Listing | 2 | 17 |
| 3.3 Compiler Listing | 2 | 17 |
| 4. PROGRAMME F | | |
| 4.1 Programme Introduction | 1 | 18 |
| 4.2 Programme Listing | 2 | 20 |
| 4.3 Compiler Listing | 2 | 20 |
| 5. PROGRAMME I | | |
| 5.1 Programme Introduction | 1 | 21 |
| 5.2 Programme Listing | 2 | 23 |
| 5.3 Compiler Listing | 2 | 23 |
| 6. PROGRAMME D | | |
| 6.1 Programme Introduction | 1 | 24 |
| 6.2 Programme Listing | 2 | 26 |
| 6.3 Compiler Listing | 2 | 26 |
| 7. THE DATA CONSTANTS FILE | 1 | 27 |
| 7.1 File Listing | 2 | 29 |
| 8. INPUT DATA | 1 | 30 |
| 8.1 Data Listings | 2 | 30 |
| 9. OUTPUT LISTINGS | 1 | 31 |
| 9.1 Output Listings | 2 | 31 |
| 10. D.E.S. OUTPUT LISTINGS | 1 | 32 |
| 10.1 Output Listings | 2 | 32 |
| Appendix 1. THE FILE SEARCH ROUTINES | 1 | 33 |
| Appendix 2. THE EVALUATION OF A 'REQUEST' | 1 | 37 |

1. INTRODUCTION

Bede College Record System (BCRS) consists of a suite of four programmes known as R, F, I and D (Records, Frequencies, Intelligence and Data Interchange).

Programme R establishes and maintains the student records. Programme F provides frequency counts on the demographic information and Programme I on the Intelligence test scores. Programme D provides the card output for the Data Interchange System with the D.E.S. at Darlington.

The BCRS system is described in the document 'BCRS Bede College Record System', April 1973, and repeated reference will be made to that document in this report.

During the development of the system the following points have been observed:

- 1.1 Wherever possible programme variable names have the same meaning throughout the system.
- 1.2 The programme structure is similar in all programmes.
- 1.3 The format of the Option Parameter card is consistent throughout.
- 1.4 The format and documentation of error/warning messages is consistent throughout.
- 1.5 The format of the output titles and the verification of the option parameters is consistent throughout.
- 1.6 Programme termination occurs when the end-of-file is encountered on the input file (scards) or in the case of programme D when the end-of-file is encountered on the Transaction file.

1.1 Programme Variables

The record structure and the programme variables used are discussed in the next section. The cross reference and attributes tables provided by the PL/1 compiler (see 3.3, 4.3, 5.3 and 6.3) provide the dimensions and the attributes of these variables.

1.2 Programme Structure

The structure of the BCRS programmes can be summarised as follows:

1.2.1 Record, variable and file declarations

This section contains the declarations of the structure RECORD,

the programme variables used and the programme files used.

1.2.2 Procedures

This section contains the internal procedures discussed in the programme introductions (see 3.1, 4.1, 5.1 and 6.1)..

1.2.3 Programme control section

This section is responsible for the input and the verification of the option parameter card, for the input of the data constants if required, and for the transfer of programme control to the requested option control section.

1.2.4 Option control sections

In the case of Programme D this section should be considered as the Transaction Control section. It is responsible for the execution of the requested option or transaction and for the output of any results.

1.2.5 The external procedure CON

The external procedure CON is required by programmes R, F and D. The procedure is CALLED from the programme control section and is responsible for the input of the data constants.

1.3 The Option Parameter Card

The Option Parameter card which is discussed in detail in section 5 of 'BCRS Bede College Record System' allows the user to inform BCRS which option is requested and which data file is to be used. The card is also used to provide option parameters if and when required.

The format of the Option Parameter card takes the following form in all programmes:

| Field | Columns | |
|-------|---------|--|
| 1 | 1- 8 | The name of the data file |
| 2 | 10-17 | The name of the data constants file |
| 3 | 19-22 | The year of the data file |
| 4 | 24-25 | The requested option |
| 5 | 27+ | Option parameter if any, terminated by a semicolon preceded by a space |

N.B. As no options are available with programme D, field 4 should be omitted. In programme I the data constants file is not required and field 2 can be omitted.

The Option parameters are listed on page 25 and discussed on pages 26 to 43 of 'BCRS Bede College Record System'. The input of the parameter values is by means of the PL/1 GET DATA instruction (see IBM PL/1 Language Reference Manual C28-8201, page 106^[46]).

1.4 Error/Warning Messages

The error/warning messages are given in Appendix 4 of 'BCRS Bede College Record System'.

The error and warning messages are divided into three groups, terminal errors, errors, and warnings. The explanation of each message takes the following form:

CLASS i : MESSAGE : The message printed by the computer when this classification of error/warning arises.

PROGRAMME : The programme in which this message appears.

OPTIONS : The options in the programme specified above, which may raise this classification of error/warning (not specified in programme D).

MESSAGE : The reason for the error/warning.

COMPUTER ACTION : The action taken by the computer when such an error/warning is encountered.

USER ACTION : The action which should be taken by the user.

1.5 Option Parameter verification and output titles

The Option Parameters are verified by the Programme Control Section and if found to be in error (or not specified when required), default values are given (see 'BCRS Bede College Record System', page 41).

As titles to each option the Programme Control Section prints the following:

BCRS BEDE COLLEGE RECORD SYSTEM

PROGRAMME k
 OPTION REQUESTED xx (omitted in Programme D)
 YEAR REQUESTED xxxx

This is followed by a list of the Option parameters in which any of the following may appear:

YEAR OF TEST x
 WRL REQUESTED xxx
 WCR REQUESTED x
 VERIFICATION PRINT REQUIRED
 DES O/P REQUIRED
 FREQUENCY TABLES REQUIRED
 PRINT INDICATOR x
 NORM TABLE REQUIRED x

where x is used to denote the value of the corresponding parameter, and k to denote the programme name.

1.6 Programme Termination

In programmes R, F and I the Option Parameter Card is responsible

for the transfer of control from the Programme Control Section to the requested Option Control Section. On the successful termination of the execution of the requested option, control is passed back to the Programme Control Section and the next Option Parameter Card is read. If an end-of-file is encountered the programme will terminate.

With programme D normal programme termination takes place when the end-of-file is encountered on the Transaction file. The transaction file is established by programme R (see 'BCRS Bede College Record System', page 22).

The Source Programme Listings

The first DATA BLOCK on the magnetic tapes **XXXXA** and **XXXXB** contain the source code of the BCRS programmes.

This data block may be divided as follows:

| | | | | | | |
|-------------|------|-------|------|----|------|-----------|
| Programme R | | lines | 1 | to | 927 | inclusive |
| Programme F | | lines | 928 | to | 1623 | inclusive |
| Programme I | | lines | 1624 | to | 2205 | inclusive |
| Programme D | | lines | 2206 | to | 2589 | inclusive |

2. PROGRAMME VARIABLES

This section discusses the programme variables used in the BCRS programmes. Wherever possible the variable names used have the same meaning throughout.

2.1 The record structure

The PL/1 structure known as RECORD provides storage for a student's record. This structure is BASED on the pointer PTR and totals 2416 bytes.

The structure of RECORD is as follows:

| Level | Structure variable name | Field |
|-------|-------------------------|----------------------------------|
| 1 | RECORD. | |
| 2 | DESNO | D.E.S. Reference No. |
| 2 | NAME | Name |
| 2 | GENERAL. | |
| 3 | PNAME | Previous surname |
| 3 | TITLE | Title |
| 3 | YC | Year confirmed |
| 3 | SEX | Sex |
| 3 | REG | Geographical region |
| 3 | DOBC | Date of birth certificate |
| 3 | MART | Marital status |
| 3 | SET | Settlement |
| 3 | POCC | Parent/Guardian occupation |
| 3 | SOCC | Student occupation |
| 2 | OV25 | Over 25 occupation |
| 3 | REL | Religion |
| 3 | CONF | Confirmation |
| 3 | DOB | Date of birth |
| 3 | TTFT(*,*) | Teachers' training (from, to) |
| 3 | AUTH | Authority/Country |
| 3 | AUTHNO | Authority No. |
| 3 | FPOS | Position in family |
| 2 | EDUCATION. | |
| 3 | SCHNO | No. of schools attended |
| 3 | SCH(*) | Schools |
| 3 | QUALNO | No. of qualifications recorded |
| 3 | QUAL(*) | Qualifications |
| 3 | UNCOL(*) | University or college attended |
| 3 | FPT(*) | Full time or part time |
| 3 | FT(*) | From, to |
| 3 | UNOTH(*) | University or other |
| 3 | DEG(*) | Title of Degree |
| 3 | HPCD(*) | Hons/Pass,Class/Division |
| 3 | SUB(*) | Main subjects |
| 3 | DATT(*) | Date of Award |
| 3 | ADIP | Diploma in Art and Design |
| 3 | ADIPC | Diploma confirmed |
| 3 | DDIPC | National Diploma confirmed |
| 3 | OQ(*) | Other Art qualifications |
| 3 | OQC(*) | Other Art qualificatns. confirme |
| 3 | ATO | Excepted by A.T.O. |

| Level | Structure variable name | Field |
|-------|-------------------------|---|
| 2 | COURSE. | |
| 3 | LEN | Course length |
| 3 | CODES(*) | Course codes |
| 3 | LE | Latest entry in Details of Course array |
| 3 | DC(*,*) | Details of course |
| 3 | DC1(*,*) | Details of course |
| 3 | DC46(*) | Details of course |
| 3 | DC49(*) | Details of course |
| 2 | FINALS. | |
| 3 | TC | Teachers' Certificate |
| 3 | WS | Wing Science |
| 3 | BE | B.Ed. |
| 3 | SUBCAR | Subsequent career |
| 2 | ANNPROG. | |
| 3 | AP | Annual Progress Vector |
| 3 | LEAP | Last entry in AP Vector |
| 3 | FK(*,*) | Field keys |
| 2 | INTEL. | |
| 3 | INTELB | Intelligence Test scores recorded |
| 3 | VALUES(*,*) | Values scores |
| 3 | DSCALE(*) | D.Scale scores |
| 3 | AH4(*,*) | A.H.4 scores |
| 3 | PF16(*,*) | P.F.16 scores |
| 3 | STEN(*,*) | Standard Ten (Sten) scores |

The character '*' is used to denote that the structure variable name refers to an array. The utilisation of these variables is as follows:

Teachers' training, from, to: TTFT(2,2)

TTFT(1,1) is used to record the date when teachers' training began and TTFT(1,2) records the date when training ended. If the student withdraws from the College, TTFT(2,1) records the characters 'WITH r' where 'r' is used to denote the reason for withdrawal. TTFT(2,1) records the characters 'LEFT' if the student completes his course. TTFT(2,2) is not used.

Schools attended: SCH(10)

The array SCH records information about the schools attended. The maximum number recorded is 10, the actual number SCHNO. Each school attendance is recorded as 5 characters as follows:

| | |
|-------------|--------------|
| school type | 1 character |
| year, from | 2 characters |
| year, to | 2 characters |

Qualifications recorded: QUAL(30)

A maximum of 30 qualifications can be recorded in any one record. The actual number recorded is given by the variable QUALNO. Each

qualification is recorded as 10 characters as follows:

| | |
|---------------------|--------------|
| year of examination | 2 characters |
| type of examination | 3 characters |
| subject code | 3 characters |
| grade | 1 character |
| pass/fail | 1 character |

Study for degree(s): UNCOL(2), FPT(2) and FT(2)
Degree(s) held: UNOTH(2), DEG(2), HPCD(2), SUB(2) and DATT(2)
Other Art qualifications: OQ(2) and OQC(2)

In these three sections storage is available for two complete entries. This corresponds to the form of the Bede College Record card (see 'BCRS Bede College Record System', page 50).

Course codes: CODES(4)

CODES records the course codes as follows: CODES(1) records the Main Subject code, and CODES(2) records the 2nd/Prov. subject code. CODES(3) and CODES(4) are not used but correspond to the fields available on card B of the Bede College Record card.

Details of course: DC(4,24:64), DC1(4,26:30), DC46(4) and DC49(4)

Storage is available for four complete entries in the section Details of Course. The latest entry is marked by the variable LE and if more than four changes are recorded the fourth entry will be overwritten. The first entry records the details of course on admission. Reference should be made to the section Details of Course on card B of the Bede College Record card.

Each entry consists of the following:

| | |
|-----------|--|
| DC(*,24) | Year of student's course |
| DC(*,25) | Repetition |
| DC1(*,26) | Late student's year begins (month) |
| DC1(*,27) | (year) |
| DC1(*,29) | Expected end of student's course (month) |
| DC1(*,30) | (year) |
| DC(*,32) | A.T.O. approval to shortened course |
| DC(*,34) | Scope of training: 5 to 7 |
| DC(*,35) | 7 to 9 |
| DC(*,36) | 9 to 11 |
| DC(*,37) | 11 to 13 |
| DC(*,38) | over 13 |
| DC(*,41) | mentally handicapped |
| DC(*,42) | not yet decided |
| DC(*,43) | Number of subjects: main |
| DC(*,44) | subsidiary |
| DC(*,45) | undecided |
| DC46(*) | Code number of main subject |
| DC49(*) | Code number of 2nd/Prov. subject |
| DC(*,59) | Postgraduate courses |
| DC(*,64) | B.Ed. course |

The remaining array elements declared are not used but they provide storage for the extra fields appearing in the corresponding section of the D.E.S. Form 30 T.T. Alterations in the course structure at the College may require the use of these fields.

Field keys: FK(100,2)

The Field Keys FK are discussed in The Annual Progress Vector, page 16.

The Intelligence Test scores: VALUES(2,6), DSCALE(2), AH4(2,3), PF16(2,16) and STEN(2,16)

A complete set of Intelligence Test scores consists of six Values scores, one D.Scale score, three A.H.4 scores, and 16 scores for the P.F.16 tests, each with a corresponding Sten score. BCRS provides storage for two sets of such scores. The first set of results VALUES(1,*), DSCALE(1), AH4(1,*), PF16(1,*) and STEN(1,*) correspond to those scores obtained in the student's first year at College, and the second set VALUES(2,*), DSCALE(2), AH4(2,*), PF16(2,*) and STEN(2,*) correspond to the scores obtained in the student's last year at College.

2.2 Programme variables

The following table provides a list of most of the programme variables used throughout BCRS. Variables included in the structure RECORD are listed but control variables and those of lesser importance are omitted.

| Variable | Usage |
|----------|-------------------------------------|
| ADIP | Diploma in Art and Design |
| ADIPC | Diploma in Art and Design confirmed |
| AGF | Age frequencies |
| AH4 | A.H.4 scores |
| AHF | A.H.4 frequencies |
| AHST | A.H.4 totals (squared) |
| AHT | A.H.4 totals |
| AK | Authority/Country keys vector |
| ALPHA | Alphabet |
| AP | Annual Progress vector |
| AQT | A'level qualification table |
| ATAB | A'level table list |
| ATAB1 | A'level card column number list |
| ATO | A.T.O. |
| AUTH | Authority/Country name |
| AUTHNO | Authority/Country number |
| AUTR | Authority/Country name list |
| AUTR1 | Authority/Country code list |
| B11 | Mathematics obtained bit |
| B61 | English language obtained bit |
| BCON | Procedure CON calling bit |
| BE | B.Ed. |
| BMAX | File divided bit |
| C | Label in programmes F and I |
| C | Card image in programme D |
| C4FLAG | Optional card 4 bit |
| CAQ | Counter, A'level qualifications |

| Variable | Usage |
|----------|---|
| CFNAME | Student Christian names |
| CLAB | Condition label array |
| CODES | Course codes |
| COND | Condition for test value |
| CONF | Confirmation |
| CONT | Continuation flag |
| COQ | Counter, O'level qualifications |
| CSC | Course/subject change |
| CSEQ | Counter, CSE qualifications grade 1 |
| DATT | Date of award of degrees held |
| DC | Details of course |
| DC1 | Details of course |
| DC46 | Details of course |
| DC49 | Details of course |
| DDIPC | National Diploma in Design confirmed |
| DEG | Title of degree held |
| DES | D.E.S. Transaction File parameter |
| DESB | D.E.S. output required bit |
| DESL | D.E.S. Number list |
| DESN0 | D.E.S. Number of current record |
| DESN02 | D.E.S. Number required in search routine |
| DESN03 | D.E.S. Number |
| DESOP | D.E.S. output file status bit |
| DHB | Degree held, Awarding Body |
| DHT | Degree held, type |
| DHY | Degree held, year |
| DOB | Date of birth |
| DOBC | Date of birth certificate confirmed |
| DOBL | Date of birth list |
| DSCALE | D.Scale score |
| DSF | D.Scale frequencies |
| DSST | D.Scale totals (squared) |
| DST | D.Scale totals |
| DT | Date variable |
| ESNAME | End of surname marker |
| FB | Frequency tables required bit |
| FILN1 | Name of data file |
| FILN2 | Name of data contents file |
| FIN | End of course date |
| FK | Field keys in Annual Progress vector |
| FPF | Position in family frequencies |
| FPOS | Position in family |
| FPT | University or college attended (Full/Part time) |
| FREQ | Frequency tables required parameter |
| FT | University or college attended (From, to) |
| GRC | Geographical regions |
| GRH | Geographical regions |
| HPCD | Hons/Pass/Class/division of degree |
| INST | Update information storage vector |
| INTELB | Intelligence Test bit |
| ITEM | Value required |

| Variable | Usage |
|----------|---|
| KC | Counter, used in procedure FIND |
| KT | Counter, number of students |
| L | Labels |
| LB | Last blank in request translation/left bit |
| LE | Latest entry in Details of Course arrays |
| LEAP | Latest entry in Annual Progress vector |
| LEN | Length of course |
| LK | Counter, logical operators within request |
| LL | Length of user's request |
| LOP | Logical operator vector |
| LPB | Left print bit |
| MAF | Marital status frequency |
| MART | Marital status |
| MK | Marital status code |
| MNT | Maximum score possible in P.F.16 tests |
| NALC | Number of A'level codes |
| NAME | Name of student |
| NAML | Name list |
| NB | Next blank in request translation |
| NORM | Tables of norms for college students |
| NORM2 | Tables of norms for college students |
| NT | Norm table required |
| NTT | Norm table required parameter |
| OAF | Area codes (pre-1972) |
| OAK | Area codes (pre-1972) |
| OK | Over 25 occupation codes |
| OKB | Old codes bit |
| OPOCF | Parent/Guardian frequencies (pre-1972) |
| OPSOK | Parent/Guardian/Student code (pre-1972) |
| OPT | Requested option |
| OQ | Other Art qualifications |
| OQC | Other Art qualifications confirmed |
| OQT | O'level qualification table |
| ORF | Religion frequencies (pre-1972) |
| ORK | Religion codes (pre-1972) |
| OV25 | Over 25 student occupation |
| OVF | Over 25 occupation frequencies |
| PB | Print bit |
| PCOND | Possible relational operators |
| PF16 | P.F.16 scores |
| PFF | P.F.16 frequencies |
| PFK | P.F.16 test codes |
| PFST | P.F.16 totals (squared) |
| PFT | P.F.16 totals |
| PI | Print indicator |
| PNAME | Previous surname |
| POCC | Parent/Guardian occupation |
| POF | Parent/Guardian occupation frequencies |
| POSEND | Position of end of update entry |
| POSEQ | Position of equals sign within update entry |
| PSOK | Parent/Guardian/Student occupation |
| PTR | Pointer |

| Variable | Usage |
|----------|---|
| Q | Number of qualifications recorded |
| QC | Qualification code |
| QE | Qualification examination |
| QG | Qualification grade |
| QP | Qualification P/F |
| QR | Qualification result |
| QUAL | Qualification recorded |
| QUALNO | Number of qualifications recorded |
| QY | Qualification year |
| R | Label array of required items |
| RB | Remaining bit |
| RC | Required card |
| REG | Geographical region |
| REL | Religion |
| REQI | User's required item |
| REQM | User's required item |
| REQU | User's required item |
| REQUEST | User's request |
| RGF | Geographical region frequencies |
| RITEM | Required item within request |
| RK | Religion codes |
| RLF | Religion frequencies |
| RPB | Remaining point bit |
| S | Number of school attended |
| SCF | School type frequencies |
| SCH | School attendance array |
| SCHNO | Number of school attended |
| SCK | School type codes |
| SET | Settlement |
| SEX | Sex |
| SF | Sten score frequencies |
| SOCC | Student occupation |
| SSST | Sten totals (squared) |
| SST | Sten totals |
| ST | School type |
| START | Start date |
| STEN | Standard Ten (STEN) scores |
| STF | Settlement frequencies |
| STK | Settlement codes |
| SUB | Main subjects of degree held |
| SUBCAR | Subsequent career |
| SUPP | Print suppression bit |
| SXF | Sex frequency |
| SYF | School year (from) |
| SYT | School year (to) |
| SW | Switch bit in sort routines |
| TC | Teachers' Certificate |
| TITLE | Title of student |
| TRANS | D.E.S. Transaction number |
| TTFT | Teachers' training (from, to) |
| TYPE | Type of student |
| UNCOL | University or college attended for degree study |
| UNOTH | University or other degree awarding body |

| Variable | Usage |
|----------|---|
| VALUES | Study of Values scores |
| VF | Values frequencies |
| VP | Verification print |
| VPB | Verification print bit |
| VPI | Verification print indicator |
| VST | Values totals (squared) |
| VT | Values totals |
| WB | Withdrawal bit |
| WC | Withdrawn code |
| WCR | Withdrawn code required |
| WD | Date of withdrawal |
| WPB | Withdrawal print bit |
| WRL | Withdrawn, remaining, left codes required |
| WS | Wing Science |
| Xi | Character string of i characters |
| XVAR | Character string varying length (max 3) |
| YC | Year confirmed |
| YE | Year of data file |
| YR | Required year of test |
| YT | Year of test parameter |

2.3 Programme files

BCRS uses three PL/1 programme files, STUDENT, CONST and DIC.

The file STUDENT refers to the file containing the students' records. It is a RECORD file with CONSECUTIVE organisation and accessed in a SEQUENTIAL manner. It is opened with one of the options INPUT, OUTPUT or UPDATE depending on the programme option required, and it contains unblocked fixed length records of 2416 bytes.

The file CONST is a STREAM file with CONSECUTIVE organisation and accessed in a SEQUENTIAL manner. It is used by the procedure CON and refers to the file containing the Data Constants.

The file DIC is also a STREAM file with CONSECUTIVE organisation and accessed in a SEQUENTIAL manner. It refers to the TRANSACTION FILE established by programme R and used by programme D.

All three files are opened with the TITLE option, allowing the user to specify on the Option Parameter Card the title (name) by which that file is to be known during the execution of that particular programme option. The title of the file STUDENT is specified in columns 1 to 8 of the Option Parameter Card, the title of the file CONST in columns 10 to 17, and the title of the file DIC by the option parameter DES.

Consider the following ERUN command:

```
ERUN reqdprog+*PLLIB PAR=FN1=MTSFN1 FN2=MTSFN2 FN3=MTSFN3
```

then if the filename given on the Option Parameter Card was 'FN1' the actual MTS file used would be 'MTSFN1', whereas if the Option Parameter Card contained the filename 'FN3' the associated MTS file would be 'MTSFN3'.

3. PROGRAMME R

3.1 Programme introduction

Programme R may be considered as the main programme in BCRS since it is responsible for the establishment and maintenance of the students' records. The Programme Options provided by programme R are discussed in section 4 of 'BCRS Bede College Record System' and can be summarised as follows:

- Option
1. Admission of records to BCRS.
 2. Input of Intelligence Test records.
 3. Annual Record Update. Transaction file established for those leaving.
 4. Set Withdrawal Code. Transaction file established for withdrawals.
 5. Admissions listing for D.E.S.
 6. File and Record listings.
 7. Late Admissions, i.e. transfers from other Training establishments. Transaction file established for late admissions.
 8. Change of course/subjects. Transaction file established for a change of course/subject.
 9. Record field alterations. Specified record print routine.
 10. Transaction file established for Admissions.

The programme structure can be divided into five sections.

1. Declarations
 - 1.1 Record declarations
 - 1.2 Variable declarations
 - 1.3 File declarations
2. Procedures
 - 2.1 RECIN, Record input
 - 2.2 CHECKREC, Record checking routine
 - 2.3 ITRECIN, Intelligence Test Record input
 - 2.4 UPDATE, Record Update routine
 - 2.5 SPNT, File listing output routine 1
 - 2.6 PRINT, Full print of current record
 - 2.6.1 CDATE, Date print routine
 - 2.6.2 GENPNT, General Information print routine
 - 2.6.3 COUPNT, Course Details print routine
 - 2.6.4 SAQPNT, Previous Education print routine
 - 2.6.5 APPNT, Annual Progress print routine
 - 2.7 SPNT1, File listing output routine 2
 - 2.8 DESPNT, D.E.S. listing output routine
3. Programme Control Section
4. Option Control Section
5. Procedure CON, Data Constants input routine

1. Declarations

The record, variable and file declarations are discussed in section 2, page 5.

2. Procedures

The function performed by the programme procedures are as follows:

- 2.1 RECIN: This procedure is responsible for the input of a student's record. The format in which the record should be prepared is given in 'BCRS Bede College Record System', Appendix 2, 2.1.
- 2.2 CHECKREC: This procedure is responsible for the verification of certain of the data values. The following fields are checked: Age, Sex, Marital Status, Religion, Settlement, Region, Parent/Guardian Occupation, Student Occupation, Over 25 Occupation, Family Position, and a Start Date check. A CLASS E error/warning message will be given for any of the above values recorded which fall outside the permissible range for that field.
- 2.3 ITRECIN: This procedure is responsible for the input of the Intelligence Test records and for the calculation of the STEN scores for the P.F.16 tests. Each Intelligence Test score is verified to ensure that it lies within the permissible range for that test, and only if all the P.F.16 scores are valid will the STEN scores be calculated. The format in which the Intelligence Test scores should be prepared is given in 'BCRS Bede College Record System', Appendix 2, 2.3.
- 2.4 UPDATE: This procedure is responsible for the input of the course results throughout the student's career. The format in which the information to be added to the records should be prepared is given in 'BCRS Bede College Record System', Appendix 2, 2.2. This information is recorded in the Annual Progress Vector and is discussed later in this section.
- 2.5-2.8 The PRINT routines: The print routines consist of procedures SPNT, PRINT, SPNT1 and DESPNT.

Calls on the routines SPNT, PRINT and SPNT1 are controlled by the option parameter PI. The following table lists the procedures used for each value of PI.

| PI | PROCEDURE | PROCEDURE TASK |
|----|-----------|--|
| 1 | PRINT | Full print of current record |
| 2 | SPNT | D.E.S. Nos. only printed |
| 3 | SPNT | List ordered alphabetically |
| 4 | SPNT1 | List ordered alphabetically within course code |

The procedure PRINT is also used to provide verification of amendments made if the option parameter VP is specified. When VP is specified the variable VPI will be set to provide a verification print as follows:

| VARIABLE VPI | AMENDMENT VERIFICATION |
|--------------|------------------------------|
| ∅ | Withdrawal |
| 1 | Change of course/subject |
| 2 | Record update |
| 3 | Full print of current record |

The output given by these procedures is discussed in 'BCRS Bede College Record System', page 27.

The procedure DESPNT is used to provide the record listings required by the D.E.S. (see 'BCRS Bede College Record System', Option 5, page 18).

Procedure utilisation

The following table lists the procedures used by each option.

| Option | RECIN | CHECKREC | ITRECIN | UPDATE | SPNT | PRINT | SPNT1 | DESPNT |
|--------|-------|----------|---------|--------|-------------------|--------------------|--------------------|--------|
| 1 | RECIN | CHECKREC | | | | | | |
| 2 | | | ITRECIN | | | | | |
| 3 | | | | UPDATE | | PRINT* | | |
| 4 | | | | | | PRINT* | | |
| 5 | | | | | | | | DESPNT |
| 6 | | | | | SPNT ⁺ | PRINT ⁺ | SPNT1 ⁺ | |
| 7 | RECIN | CHECKREC | | | | | | |
| 8 | | | | | | PRINT* | | |
| 9 | | | | | | PRINT* | | |
| 1∅ | | | | | | | | |

*In Options 3, 4, 8 and 9 the procedure PRINT will only be called if a verification print is specified on the Option Parameter Card.

⁺In Option 6 the value of the Option Parameter PI controls which of the procedures SPNT, PRINT or SPNT1 will be called.

3. Programme control section

The Programme Control Section verifies the Option Parameters specified on the Option Parameter Card, calls the external procedure CON if required and transfers control to the requested Option Control Section.

4. Option control section

The Option Control Section can be divided into three parts as follows:

- 4.1 Options 1 and 7. These options require that the file STUDENT be opened with the OUTPUT option since both options establish records in a specified file.
- 4.2 Options 2,3,4,8 and 9. With these options the file STUDENT is opened with the UPDATE option and the Specific Record Selection method discussed in Appendix 1 is used to locate the record to be updated.
- 4.3 Options 5,6 and 10. With these options the file STUDENT is opened with the INPUT option and each involves a complete pass through all the records in the specified file. See File Search Routines, Appendix 1.

5. Procedure CON

The procedure CON is responsible for the input of the Data Constants from the Data Constants File, see section 7, page 27.

The Annual Progress Vector

The Annual Progress Vector (AP) is used to record the course results throughout a student's career. The vector provides storage for 802 characters in which there may be 100 entries.

Entries are recorded in the order in which they are presented. The position of the i th entry in the AP Vector is recorded in the Field Key Vector $FK(i,1)$, and the length of that entry in $FK(i,2)$. The length of each entry includes the character '*' as a delimiter between recorded entries.

Additional information will always be added to the end of that already contained in the vector and where a field is respecified the original entry will be overwritten. The variable LEAP is used to record the next free location in the vector. The addition and removal of information from the vector can be shown diagrammatically as follows:

Consider the AP Vector as containing entries corresponding to the fields A1,A10,A16,A5 and A4 in that order as is shown below:

| | | | | | | |
|----|-----|-----|----|----|--|-------------|
| A1 | A10 | A16 | A5 | A4 | | (AP Vector) |
|----|-----|-----|----|----|--|-------------|

then the addition of an entry corresponding to the field A3 will give:

| | | | | | | | |
|----|-----|-----|----|----|----|--|-------------|
| A1 | A10 | A16 | A5 | A4 | A3 | | (AP Vector) |
|----|-----|-----|----|----|----|--|-------------|

whereas the respecification of A10 will give:

| | | | | | | |
|----|-----|----|----|-----|--|-------------|
| A1 | A16 | A5 | A4 | A10 | | (AP Vector) |
|----|-----|----|----|-----|--|-------------|

and the subsequent removal of A5 by specifying *A5=* will give:

| | | | | | | |
|----|-----|----|-----|--|--|-------------|
| A1 | A16 | A4 | A10 | | | (AP Vector) |
|----|-----|----|-----|--|--|-------------|

In each case the variable LEAP will be altered appropriately as will the Field Keys corresponding to the fields amended.

The Structure RECL

The array of structures RECL is used to provide temporary storage to those parts of the records which are required in ordered listings. It includes the variables:

| | |
|-------|----------------------------|
| NAML | Name list |
| DESL | D.E.S. Number list |
| DOBL | Date of Birth list |
| START | Start date |
| FIN | End of Course date |
| TYPE | Type of Student |
| DHT | Degree held, type |
| DHY | Degree held, year |
| DHB | Degree held, Awarding Body |

The dimension of RECL is 500, thus allowing a maximum of 499 students to be recorded. One structure, the (KT+1)th, is used in the sort routine where KT is the number of students recorded.

If the number of students appearing in the file exceeds 499 the output will be divided into groups of 499 records. Record ordering will be relevant only within each group. The following message will also be printed:

```
*****WARNING*****MAXIMUM SIZE REACHED...FILE DIVIDED
```

Data Conversion Errors

In programme R data conversions are performed in several places. If a conversion error arises during one of these conversions the following message will be printed:

```
*****DATA CONVERSION ERROR*****  
CURRENT D.E.S.NO. d.e.s.no.
```

where d.e.s.no. refers to the D.E.S. No. of the current record.

The probable cause of such an error is an improperly coded data item and as PL/1 reattempts the conversion this message will be followed by the standard system error message (IHE604I) providing the programme statement number on which the error arose.

3.2 Programme Listing

The listing of the source code of programme R is given in PART 2.

3.3 Compiler Listing

The listing of the output produced by the PL/1 Compiler during the compilation of programme R is given in PART 2.

4. PROGRAMME F

4.1 Programme Introduction

Programme F provides frequency counts on the demographic information. The Programme Options provided are discussed in 'BCRS Bede College Record System', section 4, and can be summarised as follows:

- Option 1. General Information Frequency Tables
- 2. Interrogation Routines with Optional Frequency Tables

The programme structure can be divided into five sections:

- 1. Declarations
 - 1.1 Record declarations
 - 1.2 Variable declarations
 - 1.3 File declarations
- 2. Procedures
 - 2.1 TRANS, Request translation routine
 - 2.2 LOCTST, Request evaluation routine
 - 2.2.1 FIND, Record field association routine
 - 2.2.2 TEST, Simple Request test routine
 - 2.3 SPNT, Short print routine
 - 2.4 RFREQK, Record frequency keys
 - 2.5 RECFREQ, Record frequencies
 - 2.6 RECFPNT, Record frequency print routines
- 3. Programme Control Section
- 4. Option Control Section
- 5. Procedure CON, Data Constants input routine

1. Declarations

The record, variable and file declarations are discussed in section 2, page 5.

2. Procedures

The functions performed by the programme procedures are as follows:

- 2.1 TRANS: This procedure is responsible for the translation of a user's request and is discussed in Phase 1 of the Evaluation of a Request, Appendix 2.
- 2.2 LOCTST: This procedure which includes the procedures FIND and TEST is responsible for providing an accept/reject answer for a Request with the current record. The procedure is discussed in Phase 2 of the Evaluation of a Request, Appendix 2.
- 2.3 SPNT: This procedure is used to provide a list of all the D.E.S. Nos. of all students included within a selected

sample. The printing of this list is suppressed if the number of students included exceeds 1000.

2.4 RFREQK: This procedure is responsible for printing the Frequency Table Keys of the codes used.

2.5 RECFREQ: This procedure is responsible for accumulating the frequency totals. Recorded values are checked to ensure that they are within the permissible range for that field. If they fall outside this range a CLASS E error/warning message is printed and the recorded value ignored.

2.6 RFREQPNT: This procedure is responsible for printing the frequency tables.

Procedure utilisation

The following table lists the procedures used by each option.

| Option | TRANS | LOCTST | SPNT | RFREQK | RECFREQ | RFREQPNT |
|--------|--------|--------|------|---------------------|----------------------|-----------------------|
| 1 | | | SPNT | RFREQK | RECFREQ | RFREQPNT |
| 2 | TRANS* | LOCTST | SPNT | RFREQK ⁺ | RECFREQ ⁺ | RFREQPNT ⁺ |

Procedures TRANS and LOCTST are not called with the special request, REQUEST='', provided by Option 2.

⁺The procedures RFREQK, RECFREQ and RFREQPNT will only be called when the optional frequency tables provided by Option 2 are required, or when the special request REQUEST='*' is required.

3. Programme Control Section

The Programme Control Section verifies the Option Parameters specified on the Option Parameter Card, calls the external procedure CON if required, and transfers control to the requested Option Control Section.

4. Option Control Section

The Option Control Section can be divided into two parts as follows:

4.1 Options 1 and 2 which require a complete pass through the specified file, see The File Search Routines, Appendix 1.

4.2 Option 2 with the special case REQUEST='*' which requires the Specific Selection method discussed in Appendix 1.

In both cases the file STUDENT is opened with the INPUT option.

5. Procedure CON

The procedure CON is responsible for the input of the Data Constants from the Data Constants File, see section 7, page 27.

4.2 Programme Listing

The listing of the source code of programme F is given in PART 2.

4.3 Compiler Listing

The listing of the output produced by the PL/1 Compiler during the compilation of programme F is given in PART 2.

5. PROGRAMME I

5.1 Programme Introduction

Programme I provides frequency counts on the Intelligence Test scores. The four Programme Options provided are discussed in 'BCRS Bede College Record System', section 4, and can be summarised as follows:

- Option 1. Intelligence Test totals, means and standard deviations
2. Intelligence Test Frequency Tables
3. Intelligence Test file and record listings
4. Interrogation routines

The programme structure can be divided into four sections.

1. Declarations
 - 1.1 Record declarations
 - 1.2 Variable declarations
 - 1.3 File declarations
2. Procedures
 - 2.1 ITTMS, Intelligence Test totals, means and standard deviations
 - 2.2 ITFREQ, Intelligence Test Frequencies
 - 2.3 SPNT, Short print routine
 - 2.4 PRINT, Print routine
 - 2.5 IPTMS, Print routine for totals, means and standard deviations
 - 2.6 ITPFREQ, Print routine for Frequency tables
 - 2.7 TRANS, Request translation routine
 - 2.8 LOCTST, Request evaluation routine
 - 2.8.1 FIND, Record field association routine
 - 2.8.2 TEST, Simple Request test routine
3. Programme Control Section
4. Option Control Section
 - 4.1 Options 1,2,3 and 4
 - 4.2 Option 4, special case REQUEST='*'

1. Declarations

The record, variable and file declarations are discussed in section 2, page 5.

2. Procedures

The functions performed by the programme procedures are as follows:

- 2.1 ITTMS: This procedure is responsible for accumulating the totals of the test scores and for the accumulation of the totals of the squares of these scores.
- 2.2 ITFREQ: This procedure is responsible for accumulating the frequency count totals.

In the above procedures each score is checked to ensure that it lies within the permissible range for that test. If the score lies outside the specified range a CLASS F error/warning message is printed and the score is ignored.

2.3 SPNT: This procedure is used to provide a list of the D.E.S. Nos. of all students included within a selected sample. The printing of this list is suppressed if the number of students included exceeds 1000.

2.4 PRINT: This procedure is responsible for providing a print of the Intelligence Test scores.

2.5 ITPTMS: This procedure is responsible for the calculation of the mean score and the standard deviation for each test. The procedure also provides a print routine for the output of the totals, means and standard deviations.

In the above procedure if x_i is the score obtained by student i in test x , then the mean is calculated as:

$$\left(\frac{\sum x_i}{n} \right) \text{ for } i=1 \text{ to } n, \text{ where } n \text{ is the number of students included,}$$

and the standard deviation is calculated as:

$$\sqrt{\left(\frac{\sum (x_i^2) - \frac{(\sum x_i)^2}{n}}{n} \right)}$$

2.6 ITPFREQ: This procedure is responsible for the output of the frequency tables.

2.7 TRANS: This procedure is responsible for the translation of a user's request and is discussed in Phase 1 of the Evaluation of a Request, Appendix 2.

2.8 LOCTST: This procedure which includes the procedures FIND and TEST is responsible for providing an accept/reject answer for a Request within the current record. The procedure is discussed in Phase 2 of the Evaluation of a Request, Appendix 2.

Procedure utilisation

The following table lists the procedures used by each option.

| Option | ITTMS | ITFREQ | SPNT | PRINT | ITPTMS | ITPFREQ | TRANS | LOCTST |
|--------|-------|--------|------|-------|--------|---------|--------|--------|
| 1 | ITTMS | | SPNT | | ITPTMS | | | |
| 2 | | ITFREQ | SPNT | | | ITPFREQ | | |
| 3 | | | SPNT | PRINT | | | | |
| 4 | ITTMS | ITFREQ | SPNT | | ITPTMS | ITPFREQ | TRANS* | LOCTST |

Procedures TRANS and LOCTST are not called with the special request, REQUEST='', provided by Option 4.

3. Programme Control Section

The Programme Control Section verifies the Option Parameter specified on the Option Parameter Card and transfers control to the requested Option Control Section.

4. Option Control Section

The Option Control Section can be divided into two parts as follows:

4.1 Options 1,2,3 and 4 which require a complete pass through the specified file, see The File Search Routines, Appendix 1.

4.2 Option 4 with the special case REQUEST='*' which requires the Specific Record Selection method discussed in Appendix 1.

In both cases the file STUDENT is opened with the INPUT option.

Record rejection with Option 4

With Option 4 a record without Intelligence Test information will be rejected and the Request not evaluated. In such cases a CLASS L error/warning message will be printed which does NOT necessarily mean that the record would have been accepted had Intelligence Test scores been available.

5.2 Programme Listing

The listing of the source code of programme I is given in PART 2.

5.3 Compiler Listing

The listing of the output produced by the PL/1 Compiler during the compilation of programme I is given in PART 2.

6. PROGRAMME D

6.1 Programme Introduction

Programme D provides the card output for the Data Interchange system with the D.E.S. at Darlington. The transactions provided are discussed in sections 4 and 7 of 'BCRS Bede College Record System' and can be summarised as follows:

| | | |
|-------------|----|---|
| Transaction | Ø1 | Admissions |
| | 11 | Change of course/subject, including the extension to the B.Ed. course |
| | 12 | Withdrawals/End of course |
| | 15 | Re-admission, i.e. transfer from other Training Establishments |

The programme structure can be divided as follows:

1. Declarations
 - 1.1 Record declarations
 - 1.2 Variable declarations
 - 1.3 File declarations
2. Procedures
 - 2.1 NMON, New Month calculation routine
 - 2.2 DKEY, Card Key routine
 - 2.3 DCOUR, Details of Course
 - 2.4 QUALC, Qualification calculation routines
 - 2.5 DESADM, Admissions
 - 2.6 DESWOL, Withdrawals/End of course
 - 2.7 DESCOCH, Change of course/subject/college
3. Programme Control Section
4. Transaction Control Section
5. Procedure CON, Data Constants input routine

1. Declarations

The record, variable and file declarations are discussed in section 2, page 5.

2. Procedures

The functions performed by the programme procedures are as follows:

- 2.1 NMON: This procedure is responsible for reducing a 6 character date of the form 'DDMMYY' to a 5 character date of the form 'DDMY', coding the months January to September as 1 to 9, October as '&', November as '-', and December as 'Ø'.
- 2.2 DKEY: This procedure is responsible for providing information common to all D.E.S. transactions. This information includes:

1. D.E.S. Reference No. (7 characters)
2. Sex (1 character)
3. Date of Birth (5 characters)
4. First 6 characters of Surname

2.3 DCOUR: This procedure is responsible for providing information concerning Course Details. This information is required by Transactions 01, 11 and 15. With Transactions 01 and 15 the Course Details on admission are required (i.e. the first line in the section Details of Course). With Transaction 11 the current Course Details are required (i.e. those corresponding to the latest entry (LE) in the section Details of Course).

2.4 QUALC: This procedure is responsible for the qualification analysis required to produce the information required for Card 3 of the D.E.S. Admissions transaction.

2.5 DESADM: This procedure provides the card output D.E.S. Admissions record, Transaction 01. The full record consists of five cards of which card 4 is optional and will only appear when required. The format of an Admissions record is given in 'BCRS Bede College Record System', Appendix 3, 3.1.

2.6 DESWOL: This procedure provides the card output for Transaction 12. Within the D.E.S. system Transaction 12 performs two tasks. BCRS considers Transaction 12 as Withdrawals and provides the Transaction Number '99' for End of Course transactions. The format of the cards provided by the procedure is given in 'BCRS Bede College Record System', Appendix 3, 3.2 and 3.5.

2.7 DESCOCH: This procedure provides the card output for Transactions 11 and 15. The format of the cards produced is given in 'BCRS Bede College Record System', Appendix 3, 3.3 and 3.4.

Procedure utilisation

The following table lists the procedures used by each transaction.

| Transaction | NMON | DKEY | DCOUR | QUALC | DESADM | DESWOL | DESCOCH |
|-------------|------|------|-------|-------|--------|--------|---------|
| 01 | NMON | DKEY | DCOUR | QUALC | DESADM | | |
| 11 | | DKEY | DCOUR | | | | DESCOCH |
| 12 | NMON | DKEY | | | | DESWOL | |
| 15 | NMON | DKEY | DCOUR | | | | DESCOCH |

3. Programme Control Section

This section verifies the Option Parameters specified on the Option Parameter Card and calls the external procedure CON.

4. Transaction Control Section

This section verifies the required transaction and calls the procedure required for providing the card output. A CLASS 0 error/warning message is printed after each transaction has been completed.

5. Procedure CON

The procedure CON is responsible for the input of the Data Constants. Procedure CON and the Data Constants File are discussed in section 7, page 27.

6.2 Programme Listing

The listing of the source code of programme D is given in PART 2.

6.3 Compiler Listing

The listing of the output produced by the PL/1 Compiler during the compilation of programme D is given in PART 2.

7. THE DATA CONSTANTS FILE

The Data Constants File which is required by programmes R, F and D contains the following information:

1. The Authority/Country Names and their corresponding codes
2. The General codes
3. The A'level codes and their corresponding Form 30T.T. card columns
4. The Tables of Norms for College Students

1. The Authority/Country Names and Codes

The Authority/Country Names are recorded in the vector AUTR and their corresponding codes in the vector AUTR1.

The Names are arranged in 26 groups, alphabetically by first letter only. Within each group they may appear in any order although due to the more frequent request for Authority Names they have been placed first, thus reducing search time.

The first card of this section records the number of Names within each group and this is used to calculate a key matrix as follows:

| A | B | C | D | Z |
|----|----|----|-----|---|
| 20 | 44 | 35 | 15 | 3 |
| 1 | 21 | 65 | 100 | |
| 20 | 64 | 99 | | |

Row 1 of the matrix records the first card; i.e. the number of Names within each group. This information is used to calculate rows 2 and 3.

Row 2 records the start position of each group within the vectors AUTR and AUTR1.

Row 3 records the position of the last entry of each group within the vectors AUTR and AUTR1.

To find the code corresponding to a given Authority/Country Name the position in the alphabet of the first letter of that Name is found, thus giving the required column in the key matrix. The values in rows 2 and 3 in this column provide the start and finish positions respectively of the required group within the AUTR vector. A search is made between these positions and when the required Name is found the corresponding element of the vector AUTR1 provides the required code.

Alterations to the Authority/Country listings, such as the deletion of an unwanted Name and Code or the addition of a new Name and Code, can be made very easily.

If an unwanted Name and Code is to be removed from the list,

decrease the number in the corresponding group on the first card by 1 and remove the Name and Code from the list.

If an addition is to be made to the list, increase the number in the corresponding group on the first card by 1 and insert the new Name and Code in the appropriate group within the list.

2. The General Codes

The General Codes appear in the following order within the file:

1. Old Area codes (Settlement prior to 1972)
2. Old Religion codes (prior to 1972)
3. Old Parent/Guardian/Student Occupation codes (prior to 1972)
4. School Type codes
5. Parent/Guardian/Student Occupation codes
6. Settlement codes
7. Marital Status codes
8. Over 25 Occupation codes
9. Religion codes
10. Geographical Region codes

3. The A'level Codes

The A'level Codes are recorded in the vector ATAB and their corresponding Form 30 T.T. card columns are recorded in the corresponding elements of the vector ATAB1.

The codes are recorded in pairs in the Data Constants File, each A'level code being followed by its corresponding card column. The full list is preceded by the number of pairs which is recorded in the variable NALC.

To make an addition to the list the variable NALC must be altered appropriately and the new pair of codes added to the list.

To delete a pair of codes from the list the variable NALC must again be altered appropriately and the unwanted pair removed from the list. Following pairs must then be moved in order to ensure that no gaps appear within the list.

4. The Table of Norms for College Students

The two Tables of Norms for College Students which are recorded by BCRS are given on pages 42 and 43 of 'BCRS Bede College Record System'.

In the Data Constants File only the upper bounds of each range of new scores appearing within the body of the tables are recorded. The corresponding STEN scores are calculated from these upper bounds in the procedure ITRECIN, programme R.

The information in the Data Constants File is read by the external procedure CON. This procedure will be called only when required for the first time by programmes R and F. It will not be subsequently called if required again during the same programme execution. The procedure is always called by programme D.

7.1 File Listing

A listing of the Data Constants File is given in PART 2.

8. INPUT DATA

The input data to all options in BCRS must consist of an Option Parameter Card. In some cases this card is accompanied by further information presented in the form:

OPTION PARAMETER CARD

DATA (Records or Amendments)

In Section 8.1 (Data Listings, see PART 2) several examples of input data listings are provided.

The examples given are as follows:

8.1.1 Data listings for Programme R

- 1 Admissions records
- 2 Intelligence Test records
- 3 Annual updates
- 4 Withdrawals
- 5 Changes of course/subject
- 6 Specific field alterations

8.1.2 Data listings for Programmes F and I

- 1 The special request, REQUEST='*',
in programme F
- 2 The special request, REQUEST='*',
in Programme I

8.1.3 Selected option parameter cards

The examples for 8.1.1 and 8.1.2 are all of the form given above. The examples for 8.1.3 consist only of Option Parameter Cards.

The format describing the data appearing in the examples in 8.1.1 is given in 'BCRS Bede College Record System', Appendix 2.

9. OUTPUT LISTINGS

In Section 9.1 (Output Listings, see PART 2) several examples are given of the output from BCRS.

10. D.E.S. OUTPUT LISTINGS

All cards sent to the D.E.S. should be accompanied by a corresponding listing. In Section 10.1 (Output Listings, see PART 2) examples are provided of the listings for the following transactions:

- 01 Admissions
- 11 Change of course/subject including the extension to a B.Ed. course
- 12 Withdrawals
- 15 Re-admission, i.e. a transfer from another Training Establishment

Teachers' Training Section at the D.E.S. also require a listing of the admissions as given by Programme R, Option 5. An example of this listing for the admissions in 1972 is also provided.

Appendix 1

THE FILE SEARCH ROUTINES

APPENDIX 1. THE FILE SEARCH ROUTINES

The BCRS data files are organised sequentially in ascending order of D.E.S. No. One of the characteristics of this type of organisation is that it provides rapid access to successive records but slow access to records out of sequence. For this reason the maximum efficiency with a given set of updates is achieved when the D.E.S. Nos. of these updates are placed in ascending order to coincide with the order of the records in the file.

In BCRS the task or tasks of the requested Programme Option gives rise to the method of record selection. Two methods are used:

1. The Complete Pass
2. Specific Record Selection

1. The Complete Pass is used when all the records of a given file are required. Records are selected in sequence starting with the first and terminating when the End-of-file is reached whereupon control passes to a pre-set ENDFILE routine. This method is shown diagrammatically in Figure 1, page 35.

2. Specific Record Selection is used when a given record is to be found, or when a given set of records are required. In this method the ENDFILE routine closes and re-opens the file, thus returning the Read heads to the start of the file; and termination of the search cycle occurs when the terminating characters '*****' are input.

This method, which is shown diagrammatically in Figure 2, page and flowcharted in Figure 3, page 36, can be divided into steps as follows:

- Step 1 Initialise the 'record not found' bit to \emptyset , i.e. 'off'.
- Step 2 Read the first/next D.E.S. No. of the record to be found. If this D.E.S. No. is '*****' then branch out of the cycle.
- Step 3 Read the first/next record from the data file. This record now becomes known as the 'current' record.
- Step 4 Compare the D.E.S. No. of the current record with the D.E.S. No. of the record to be found.
- Step 5 If the D.E.S. Nos. compared in Step 4 are equal, the current record is the record required, and after performing the required operations control passes back to Step 1.
- Step 6 If the D.E.S. Nos. compared in Step 4 are not equal and the 'record not found' bit is off, the bit is set to 1, i.e. 'on', and the D.E.S. No. of the current record recorded. Control is then passed back to Step 3.

If the 'record not found' bit is 'on' and the current D.E.S. no. is not equal to the recorded D.E.S. No., control passes back to Step 3.

If the 'record not found' bit is 'on' and the current D.E.S. No. is equal to the recorded D.E.S. No., then the required record cannot be found, and after printing a CLASS C error/warning message control is passed back to Step 1.

With reference to Figure 2 on page 35, consider a search for Record k where the current record is Record i. The next record, Record i+1, becomes the current record, and if this is not equal to Record k, the required record, searches are made from Record i+1 to Record n, and from Record 1 to Record i+1, until Record k is found. If Record k is not found the search cycle is stopped at Record i+1.

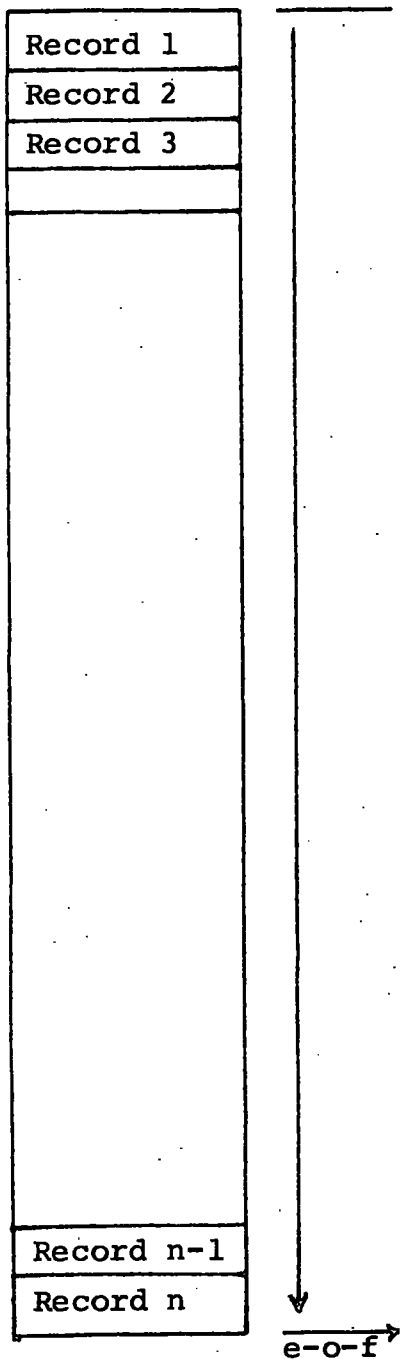

FIGURE 1

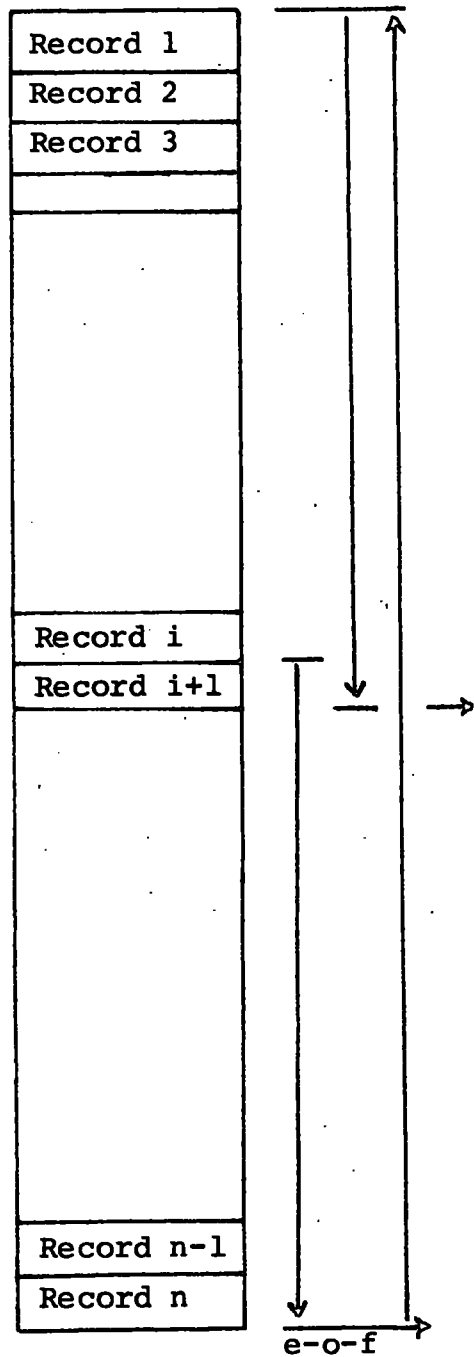

FIGURE 2

Diagrammatic representation of:

FIGURE 1. The Complete Pass

FIGURE 2. Specific Record Selection

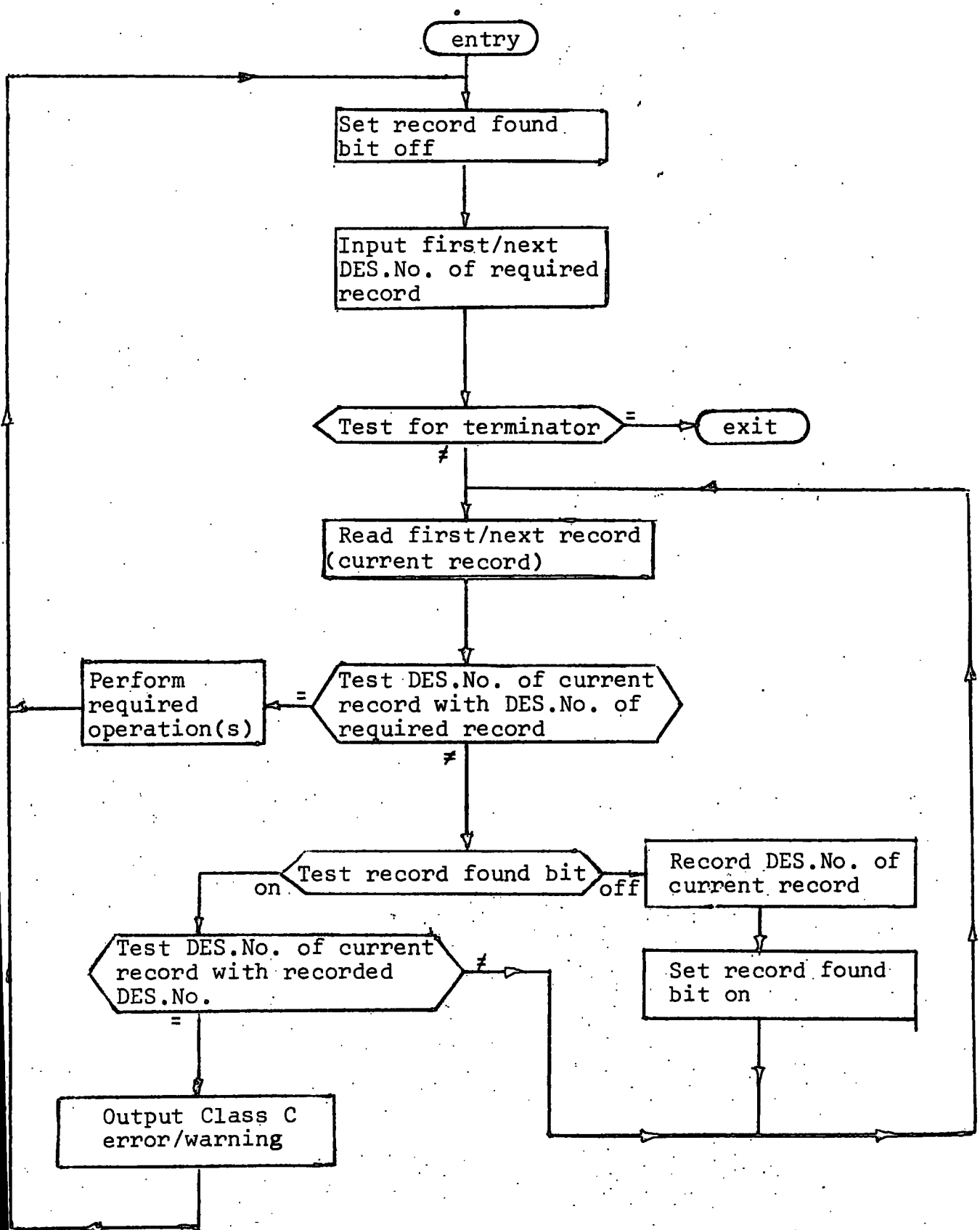

Figure 3. Flowchart of Specific Record Selection

Appendix 2

THE EVALUATION OF A REQUEST

APPENDIX 2. THE EVALUATION OF A REQUEST

Phase 1. The Translate Procedure

This phase in the evaluation of a REQUEST involves the translation of a coded request into four vectors, LOP (Logical Operator), RLAB (Required Label), CLAB (Condition Label) and RITEM (Required Item).

These vectors can be represented in tabular form as follows:

| | LOP | RLAB | CLAB | RITEM |
|----|-----|------|------|-------|
| 1 | | | | |
| 2 | | | | |
| 3 | | | | |
| ⋮ | | | | |
| 2∅ | | | | |

Each line in this table is used to record a SIMPLE REQUEST. The variable k records the number of simple requests recorded (1 ≤ k ≤ 2∅).

The vector LOP records the Logical Operators which precede each simple request with the exception of the first.

The vector RLAB records the Required Item Numbers.

The vector CLAB records the codes corresponding to the required Relational Operators. These codes are as follows:

| | | | | | | |
|---------------------|---|---|---|---|---|---|
| Relational Operator | = | ≠ | > | ≧ | < | ≦ |
| CLAB Code | 1 | 2 | 3 | 4 | 5 | 6 |

The vector RITEM records the required Item Values.

Consider as an example one of the requests given on page 32 of 'BCRS Bede College Record System'.

Select as a subset "those students who have more than 2 A'level passes and an O'level pass in English Language or Mathematics".

This request was reduced to three simple requests:

1. has the student more than 2 A'level passes?
2. has the student an O'level pass in English Language?
3. has the student an O'level pass in Mathematics?

which were combined to produce the fully coded request as:

REQUEST=' 21>2(****A****P) & 21≠<1(****O∅61*P) | 21≠<1(****O∅11*P) '

With this request phase 1 will produce a table as follows:

| | | | | |
|-----|---|----|---|---------------|
| 1 | | 21 | 3 | 2(****A****P) |
| 2 | & | 21 | 6 | 1(****OØ61*P) |
| k=3 | | 21 | 6 | 1(****OØ11*P) |
| | | | | |
| | | | | |
| | | | | |
| 2Ø | | | | |

The final stage in phase 1 concerns the checking of the RLAB vector to ensure that only valid ITEM NUMBERS are recorded. Programme F allows 1 to 4Ø ITEM NUMBERS and Programme I 1 to 66. If an RLAB value is found outside these ranges a CLASS G error/warning message is given and the complete line removed from the table.

A flowchart of Phase 1 is given in Figure 1, page 42.

Phase 2. The Locate and Test Procedure

Phase 2 in the evaluation of a request is responsible for providing a true/false (accept/reject) answer for that request with the current record. In some circumstances not all the simple requests of a given request need be evaluated to provide this answer. The following rules govern the evaluation of the k simple requests within the request.

1. Logical Operators are evaluated from LEFT to RIGHT.
2. If the answer to a simple request is false and that simple request is followed by the Logical Operator '&' the whole request is false.
3. If the answer to a simple request is false and that simple request is followed by the Logical Operator '|' the next simple request is tested.
4. A simple request preceded by the Logical Operator '|' will not be tested if the preceding simple request is true.

Each simple request is evaluated in two stages.

Stage 1. The FIND Procedure

The Procedure FIND forms an association between the RLAB of the simple request under consideration and its corresponding Record field. Calculations and conversions are performed where necessary to ensure that the ITEM returned by this procedure is a character string of varying length.

Stage 2. The TEST Procedure returns a true/false answer to a given simple request using as a relational operator for the test the operator corresponding to the CLAB code recorded for the simple request under consideration. The test is made between the ITEM returned by the procedure FIND and the RITEM of the simple request.

The sequence in which the simple requests are evaluated is flow-charted in Figure 2, page 43.

Exception Routines

Due to the incompatibility of the data recorded in the years prior to 1972 and the need for more information when evaluating certain Requests, several exception routines have been incorporated.

The following ITEM NUMBERS are exceptional cases and give rise to the need for an exception routine:

- ITEM NO. 4 Settlement
- 6 Parent/Guardian Occupation
- 7 Student Occupation
- 9 Religion
- 19 School Types
- 21 Qualifications
- 24 Course Codes
- 36 Annual Progress Vector
- 4Ø First Appointment

In each of these cases the Item Value is followed by additional information. This information is always enclosed in parentheses and can be shown as follows:

Item No. 4,6,7,9 and 4Ø

| | Year | | | |
|---|------|--|--|---|
| (| | | |) |

Item No. 24

| | Main or 2nd Prov. | | | |
|---|-------------------|--|--|---|
| (| | | |) |

Item No. 19

| | School | From | To | |
|---|--------|------|----|---|
| (| | | |) |

Item No. 21

| | Year | Type | Code | Grade | P or F | |
|---|------|------|------|-------|--------|---|
| (| | | | | |) |

Item No. 36

| | Year | Field Label | |
|---|------|-------------|---|
| (| | |) |

During the Request Evaluation Sequence, see Figure 2, three tests are made to locate these Item Numbers.

1. The first test on finding one of these cases removes and records all the additional information including the parentheses from the Item Value.
2. The second test concerns only Item Numbers 4,6,7,9,36 and 40. On finding one of these cases a test is made between the field 'Year' and the year in which the student entered the College. If the years are not equal, the codes recorded are not compatible with the required code in this Simple Request and the next Simple Request, if any, is considered.
3. The third test on finding any of the above cases removes and records the number required from the Item Value.

The additional information given with Item Numbers 19, 21 and 36 is further processed in the procedure FIND.

With Item Nos. 19 and 21, variables are defined over each field within the additional information as follows:

Item No. 19

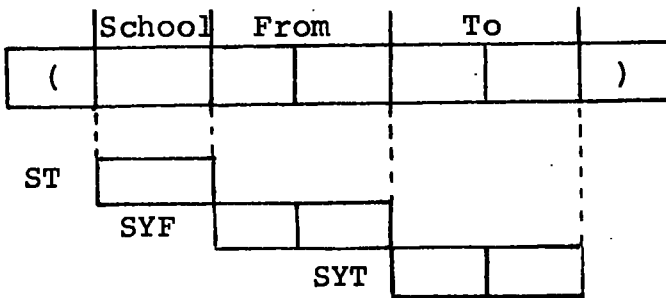

Item No. 21

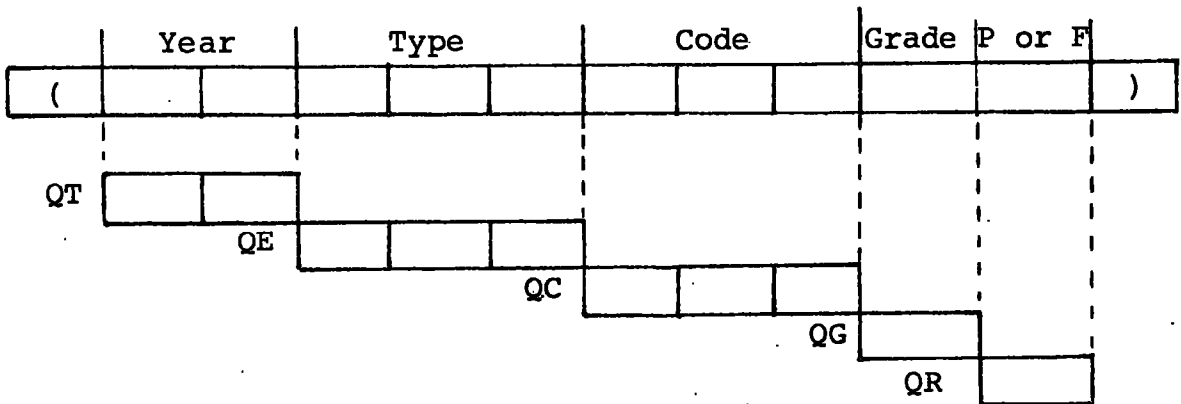

These variables are then compared with each of the Schol Attendances or Qualifications recorded and a total kept of the number of complete matches that are made over all fields. If a variable consists of the character/s '*' this field is accepted as 'true' regardless of the value of the corresponding recorded field. In such cases the field value required can be considered as any. For example, the additional information of '(**A**P)' following a request

involving qualifications can be interpreted as an A'level pass in 'any' year, in 'any' code (subject), with 'any' grade.

The value of the variable ST defined over the additional information for Item Number 24 is used as a subscript in the CODES vector. In Item Number 36 the value of the Field Label is copied from the additional information and used as a subscript in the Field Label vectors which provide pointers to the locations of the corresponding information in the Annual Progress Vector.

The special request REQUEST='*'

With this request no evaluation is required as the user specifies as data the D.E.S. Nos. of the students to be considered.

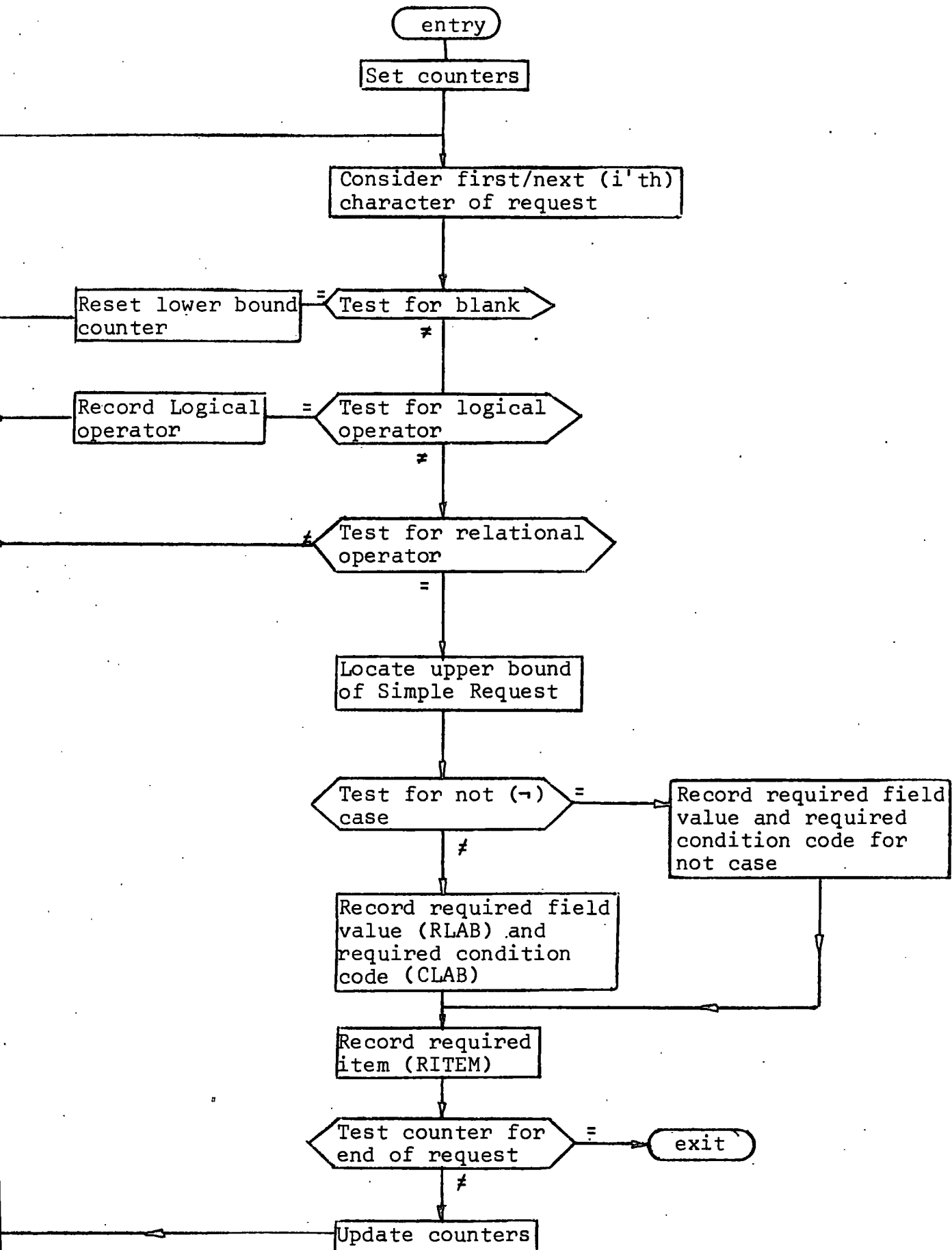

Figure 1. Phase 1 of the Evaluation of a Request

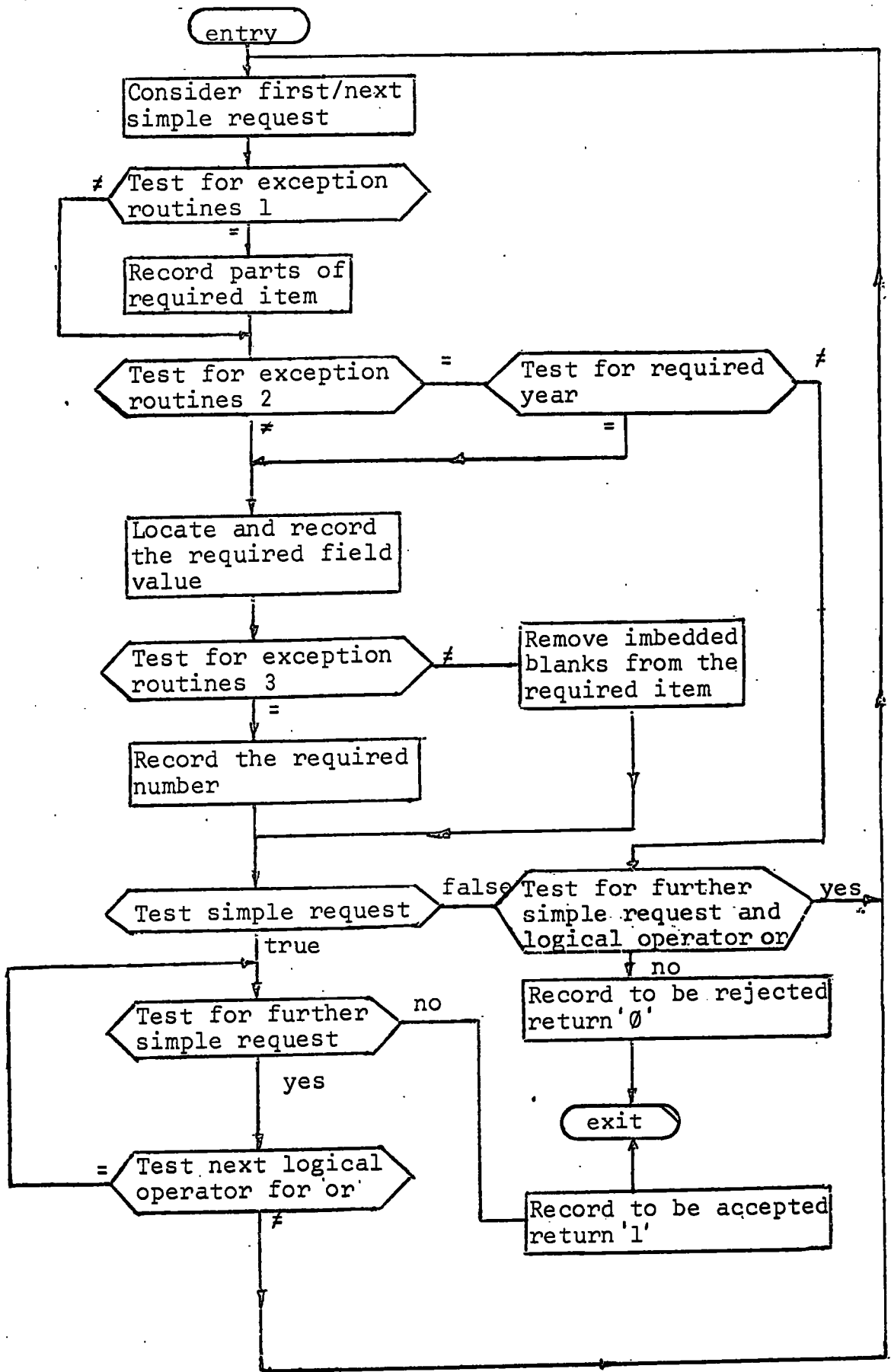

Figure 2. The Request Evaluation Sequence.