

## Durham E-Theses

---

# *The spatial dynamics of commercial activity in central Sunderland*

D. J. Blair

### How to cite:

---

Blair, D. J. (1977) The spatial dynamics of commercial activity in central Sunderland. Masters thesis, Durham University.

### Use policy

---

The full-text may be used and/or reproduced, and given to third parties in any format or medium, without prior permission or charge, for personal research or study, educational, or not-for-profit purposes provided that:

- a full bibliographic reference is made to the original source
- a <https://etheses.durham.ac.uk/id/eprint/10018/> is made to the metadata record in Durham E-Theses
- the full-text is not changed in any way

The full-text must not be sold in any format or medium without the formal permission of the copyright holders.

Please consult the [full Durham E-Theses policy](#) for further details.



THE SPATIAL DYNAMICS OF  
COMMERCIAL ACTIVITY IN  
CENTRAL SUNDERLAND

Thesis submitted as a requirement for the  
MASTER OF ARTS  
with the Faculty of Social Sciences  
UNIVERSITY OF DURHAM

Sunderland Polytechnic

D. J. Blair  
March 1977

The copyright of this thesis rests with the author.  
No quotation from it should be published without  
his prior written consent and information derived  
from it should be acknowledged.

<u>List of Contents</u>	<u>Page</u>
Frontispiece	(i)
Abstract	(ii)
Contents of Chapters	(iii)-(v)
Figures (lists)	(vi-vii)
Tables (lists)	(viii)
Appendices (lists)	(ix)
Acknowledgements	(x)
Introduction	1-6
Chapter 1	7-18
Chapter 2	19-28
Chapter 3	29-50
Chapter 4	51-76
Chapter 5	77-107
Chapter 6	108-144
Chapter 7	145-178
Chapter 8	179-187
Bibliography	188-200
Appendices	201-228

Frontispiece

CENTRAL SUNDERLAND FROM THE SOUTH WEST

- A - the commercial core in 1800
- B - the main retail area in 1976
- C - the main office area in 1976
- D - area of growth
- E - area of decline

Abstract

Faculty of Social Sciences

Geography

Master of Arts

Spatial dynamics of commercial activity in central Sunderland.

D.J. Blair

A case study of the changing structure and behaviour of a commercial core of Sunderland is presented in the light of pertinent strands of theory. Considerable change is observed involving both internal reorganisation as well as external relocations.

In 1800 the commercial core of Sunderland was a small and functionally mixed area tied very closely to the river and the port trade. Throughout the nineteenth and twentieth centuries, the commercial core expanded and shifted in response to economic change and the spread of residential areas. The modern C.A., therefore, contains greater functional segregation and more intense commercial activity.

The present C.A. is delimited according to generally accepted methods. The spatial behaviour of commercial establishments is investigated with respect to birth, life, death, directional and distance parameters. The responses of individual managers and firms to changing circumstances in central Sunderland are surveyed. General spatial patterns are discernible at varying scales which confirm expected tendencies.

Finally, some generalisations on the process of commercial change in a central area are suggested by reference to a flow diagram and set of indices, which hold for all places and at all times.

<u>CONTENTS</u>	<u>Page</u>
<u>Introduction</u>	1-6
- the scope of the thesis	1
- the case of Sunderland	2
- the clarification of terms	3
- the organisation of the thesis	4
- operational procedures and problems	5
- references and end notes	5
<u>SECTION A.            THEORY AND METHODOLOGY</u>	
<u>Chapter 1.            A survey of research literature on central areas</u>	7-18
- introduction	7
- non British literature	7
- British literature	10
- other literature relevant to the C.B.D. and C.A.	12
- summary	14
- references and end notes	15
<u>Chapter 2.            Theoretical background to the study of central areas                           with particular reference to Sunderland</u>	19-28
- introduction	14
- economic perspectives	19
- population perspectives	21
- ecological perspectives	23
- behavioural perspectives	24
- classical perspectives	25
- planning perspectives	26
- summary	27
- references and end notes	27
<u>SECTION B.            METHODS AND RESULTS</u>	
<u>Chapter 3.            The origins and growth of a central area in                           Sunderland, during the nineteenth century</u>	29-50
- introduction	29
- economic stimuli of the C.A.	29
- morphological characteristics of the C.A.	33
- functional characteristics of the C.A.	35
- land values and commercial change	43
- summary	46
- references and end notes	47

<u>Chapter 4.</u>	<u>Land use changes in central Sunderland during the twentieth century</u>	<u>Page</u>
		51-76
-	introduction: the nature of change	51
-	the data and procedures	52
-	probability transition matrices : method	58
-	probability transition matrices : results	61
-	tests of significance of land use conversion	71
-	summary	75
-	references and end notes	75
<u>Chapter 5.</u>	<u>The delimitation and internal structure of the C.A. of Sunderland</u>	<u>77-107</u>
-	introduction	77
-	data and application of method	78
-	results	79
-	validity of the delimited C.A.	82
-	some characteristics of the C.A. of Sunderland	86
	(i) size (ii) shape (iii) age (iv) land values	
-	internal structure	92
	(i) functional segregation (ii) external structure	
-	land use by zones	98
-	land use by floor levels	102
-	summary	104
-	reference and end notes	105
<u>Chapter 6.</u>	<u>The location of commercial activity in central Sunderland</u>	<u>108-144</u>
-	introduction	108
-	a conceptual framework for studying commercial change	108
-	data sources and operational aspects	109
-	evidence of the birth-life-death concept	114
	(i) 'births' (ii) 'deaths' (iii) 'migrants' (iv) 'stayers'	
-	some principles of commercial change	135
-	summary	142
-	references and end notes	143

<u>Chapter 7.</u>	<u>Some behavioural aspects of commercial change in central Sunderland</u>	<u>Page</u> 145-178
-	introduction	145
-	spatial behaviour and location strategy of (i) shops (ii) offices	145
-	a survey of factors governing the decision to migrate (i) sample frame (ii) data collection (iii) analysis of results	154
-	locational strategies of two individual establishments (i) Vaux Brewery (ii) Binns Departmental Store	163
-	some spatial parallels of Vaux and Binns	172
-	summary	175
-	references and end notes	176
<u>SECTION C.</u>	<u>POSSIBILITIES, CONCLUSIONS, AND RESERVATIONS</u>	
<u>Chapter 8.</u>	<u>Towards a working model of C.A. change and summary</u>	179-187
-	introduction	179
-	a systems approach to C.A. change	179
-	a working model of C.A. commercial change	181
-	summary and reservations	184
-	references and end notes	187

<u>FIGURES</u>	<u>Page</u>
Fig. 1. A schematic representation of the genesis of a central area in Sunderland.	3
Fig. 2. A model of central area change.	20
Fig. 3. Hypothetical relationships between a C.A. and urban growth	22
Fig. 4. A generalised map of urban spread of centres of gravity of population, 1800-1855.	32
Fig. 5. Topographic factors in central Sunderland.	32
Fig. 6. Rains Eye Plan, 1792.	34
Fig. 7. A model of morphological development in street blocks.	36
Fig. 8. Sunderland's commercial core, 1800-1850.	38
Fig. 9. Land values in central Sunderland, 1850 and 1900.	44
Fig. 10. Changing limits of the C.A. of Sunderland.	46
Fig. 11. Grid system and street locations.	53
Fig. 12. Sample points (A) and Land use trends (B).	56
Fig. 13. Delimitation of central Sunderland by the Murphy-Vance method.	81
Fig. 14. Shop frontages in central Sunderland.	83
Fig. 15. Comparative delimitations of the C.A. of Sunderland.	85
Fig. 16. Age structure of central Sunderland.	89
Fig. 17. Land values in central Sunderland. 1975.	91
Fig. 18. Triangular graph of central business uses by cells.	93
Fig. 19. Comparative data on offices space (A) and shop space (B)	95
Fig. 20. Some central points in the C.A. of Sunderland.	97
Fig. 21. Land use by zones in central Sunderland.	99
Fig. 22. Land uses in relation to floor levels, central Sunderland.	101
Fig. 23. Rates of change in land use at different floor levels.	103
Fig. 24. Commercial 'births' in central Sunderland, 1966-1975.	113
Fig. 25. Commercial 'deaths' in " " , 1966-1975.	120
Fig. 26. Migration of retail establishments, 1966-1975.	125
Fig. 27. " " office " 1966-1975.	126
Fig. 28. " " service " 1966-1975.	127

<u>FIGURES</u>	<u>Page</u>
Fig. 29. Distance migrated by commercial establishments.	129
Fig. 30. Directional bias in migration of establishments.	130-131
Fig. 31. Distribution of 'stayers'.	133
Fig. 32. Measures of commercial change, 1966-1975.	136
Fig. 33. Relationship of 'births' and 'deaths'.	138
Fig. 34. Relationship of in - and out - migrants.	141
Fig. 35. Mean centres of urban functions.	147
Fig. 36. Distribution of selected types of shops, 1962 (A) and 1975 (B).	149
Fig. 37. Distribution of Insurance Agents, (A), Banks and Building Societies, (B), Solicitors, (C), and Estate Agents, (D), 1975.	
Fig. 38. The spatial history of Vaux Brewery, 1894-1959.	165
Fig. 39. Vaux Brewery, 1976.	167-120
Fig. 40. The spatial history of Binns, 1927-1975.	
Fig. 41. The accretion process of Vaux and Binns, 1894-1975.	173
Fig. 42. A systems diagram of the spatial dynamics of commercial activity in a C.A.	180

<u>TABLES</u>	<u>Page</u>
Table 1. The urban growth of Sunderland in the nineteenth century.	31
Table 2. Classification of commercial activity in High and Low Streets in 1831.	40-41
Table 3. Summary of land use change, 1894-1975.	55
Table 4. Land use conversion data, 1894-1975.	62
Table 5. Land use succession, 1894-1927	64
Table 6. " " " 1927-1948	65
Table 7. " " " 1948-1959	67
Table 8. " " " 1959-1975	69
Table 9. Total land use changes, 1894-1927-1948-1959-1975.	70
Table 10. Land use Gains and Losses in central Sunderland.	72
Table 11. Chi-square values for 1894-1975, land use data.	74
Table 12. Method of collection of floor space data.	78
Table 13. C.B.H.I. and C.B.I.I.: two ratios of the Murphy-Vance method.	86
Table 14. Floor space in central Sunderland by zones.	98
Table 15. Land use in central Sunderland by floor levels.	102
Table 16. Analysis of commercial 'births' in central Sunderland, 1966-1975.	115-6
Table 17. Analysis of commercial 'deaths' in central Sunderland, 1966-75.	122-3
Table 18. Analysis of commercial 'stayers' in central Sunderland, 1966-1975.	134
Table 19. Composition of respondents.	157
Table 20. Factors influencing commercial migration.	159
Table 21. Reason for migration.	159

<u>APPENDICES</u>		<u>Page</u>
App. 1.	Rates of population growth related to coal and shipping data.	201
App. 2.	Garbutt's map of Sunderland, 1817.	202
App. 3.	Robson's plan of Sunderland, 1827.	203
App. 4.	Robson's plan of Sunderland, 1844.	204
App. 5.	Robson's plan of Sunderland, 1850.	205
App. 6.	Analysis of 1838 Rate Book.	206
App. 7.	Analysis of 1850 Rate Book.	208
App. 8.	Property use and residential structure of Fawcett Street, 1871.	209
App. 9.	Ordnance Survey grid for central Sunderland.	210-212
App. 10.	Observed and expected land use change, 1894-1927.	213
App. 11.	" " " 1927-1948.	214
App. 12.	" " " 1948-1959.	215
App. 13.	" " " 1959-1975	216
App. 14.	Land use survey system (1970 Planning Survey).	217
App. 15.	C.A. land use data, 1970.	218
App. 16.	Land use floor levels : (A) core. (B) non-core.	219
App. 17.	Distribution of Central and Non Central Land Use by Floor Levels (in sq. metres)	220-222
App. 18.	National Gazetteer System	223-225
App. 19.	Classification of commercial establishments.	225-227
App. 20.	Questionnaire on the factors affecting the location and migration of services, offices and businesses.	228

ACKNOWLEDGEMENTS

The writer should like to express his gratitude to all the people who have helped in the compilation of this thesis.

Individual thanks must be made to staff at Sunderland Public Reference Library, Sunderland Museum and Sunderland Polytechnic library, especially Mr. M. White, Mr. M. Wilson and Mrs. E. Stephenson respectively; to Mrs. G. Newman and Mrs. M. Temple of the Computer centre of Sunderland Polytechnic; to Messrs. T. McKitterich, I. Knowles, K. Butler and W. Liddle of Sunderland Polytechnic for their reprographic help; to Mr. N. Dibben of the Planning Department, Sunderland Borough; to Mr. Allison, Civic Centre, Sunderland for archive material; to Mr. T.H. Biss of Guest, Keen and Nettlefold, Bromsgrove for comments on Chapters 5 and 8; to Mr. G. Whitfield for comments on Chapter 4; to Mr. G. Jackson for drawing all the maps; to the students and respondents who were involved in the questionnaire survey; to Turners (Photographers) Ltd., Pink Lane, Newcastle upon Tyne, for permission to use the aerial photograph; to Sunderland Polytechnic for financial assistance; to Mrs. G. Lewins for typing the manuscript, and to Dr. D.C.D. Pocock who read the drafts for each chapter and acted as a helpful supervisor throughout.

## INTRODUCTION

### The scope of the thesis

This thesis has the ambitious aim of examining the spatial dynamics of commercial activity in central Sunderland. The origins and growth and the processes which have shaped its functional and morphological structure are prime considerations. Such subject matter is of interest to a wide range of urban scholars, including planners, economists and urban historians; however, here the geographical approach is dominant.

The commercial core of towns and cities is a recognised field of geographical enquiry,<sup>(1)</sup> in which research has tended to emphasise both functional<sup>(2)</sup> and morphological<sup>(3)</sup> aspects.<sup>(4)</sup> The spatial structure and morphology of a modern central area are the product of extremely complex evolutionary processes. Sunderland provides a valuable case study of central area change in which various ideas and assumptions can be tested.

### The case of Sunderland

The urban structure of Sunderland has already been analysed in a classic geographical study,<sup>(5)</sup> in which reference was made to various spatial patterns and trends. By confining attention in this work to the central area, existing knowledge is hopefully supplemented. Apart from its accessibility to the writer, Sunderland provides a classic case of central area change over a long time period. Unlike most other large towns, the commercial centre of Sunderland has shifted about one and a half kilometers since 1800. At that time, central commercial activity was still emerging from its pre-industrial<sup>(6)</sup> pattern of mixed residential-industrial-commercial uses. Throughout the nineteenth century, the industrial (capitalist)<sup>(7)</sup> system, however, transformed the urban morphology. Commercial activities began to group in the most accessible location within the expanding town. Later, in the twentieth century, corporate planning decisions to develop and redevelop generated a new planned central area. Sunderland, therefore, provides valuable comparative<sup>(8)</sup> information as an industrial town with origins in the mercantile era of the nineteenth century which has been progressively altered by changing circumstances.

The genesis of the central area of Sunderland is represented schematically in Fig.1 to serve as an introductory overview.<sup>(9)</sup> Anthropomorphic age classes are not employed but sufficient evidence has been presented<sup>(10)</sup> to suggest that the use of 'stages' may have some value in the study of the

evolution of central Sunderland. (Fig. 1.)

About 1800 (Stage 1, ), there were three separate, small settlements. (see Chapter 3). The central area was located in the centre of the largest grouping of population and was spatially contiguous with the port area. The central area was small, elongated west-east and, commercially, in an incipient stage. By c.1850 (Stage II), the three original settlements had coalesced. The central area had emerged as a functionally distinct urban region; it had broken away from its river connections being anchored along High Street East and West, and had definite growth tendencies in a westerly direction. In 1900, (Stage III), outward expansion of the built up area, especially to the south and west, generated further expansion in the commercial central core. Furthermore, the penetration of the railway, via a second bridge, into the Fawcett Street area, meant that a distinct north-south component was added to the central area growth pattern. Two other processes had manifested themselves by this stage: internal specialisation had produced a distinct office quarter in the John Street area; and, decline and contraction were responsible for the usual symptoms of discard and blight in the old east-end. By c.1950, (Stage IV the commercial core was being shaped by barriers to north and south, by the street pattern and by the availability of suitable buildings. The leap-frogging of commercial activity into inner residential streets in the south west was in response to the post-war metropolitan growth in Greater Sunderland. The extension of administrative boundaries and the construction of large housing estates on the outskirts of Sunderland pulled the centroid of the population distribution westwards.<sup>(11)</sup> The conversion of an area of mixed land uses into a planned retail precinct increased the size of the central commercial area considerably and produced (Stage V, c.1975) a more compact central area; but with increasingly well defined barriers to further expansion.

#### Clarification of terms

The complexity of the structure and behaviour of the central commercial area over a long time span necessitates a broad approach. An understanding of the spatial dynamics of commercial activity in the central area involves consideration of its physical attributes, such as site, location and accessibility. It also, involves less tangible characteristics, such as local, regional and national economics, as well as social and psychological considerations. Urban land use reflects the decisions of thousands of

c 1800

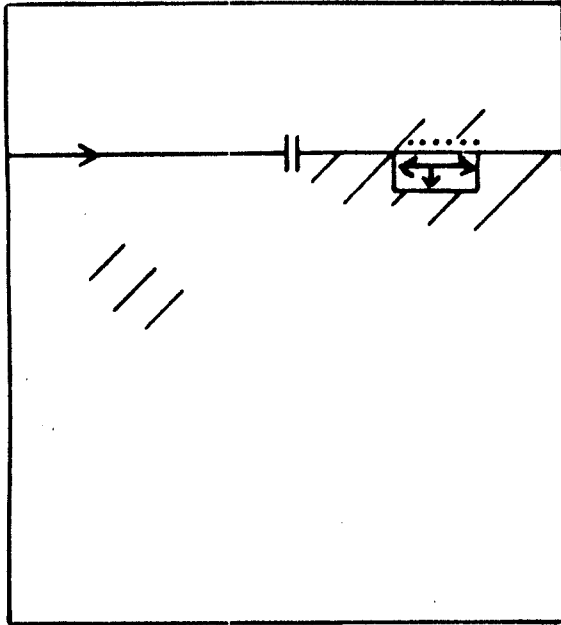

c 1850

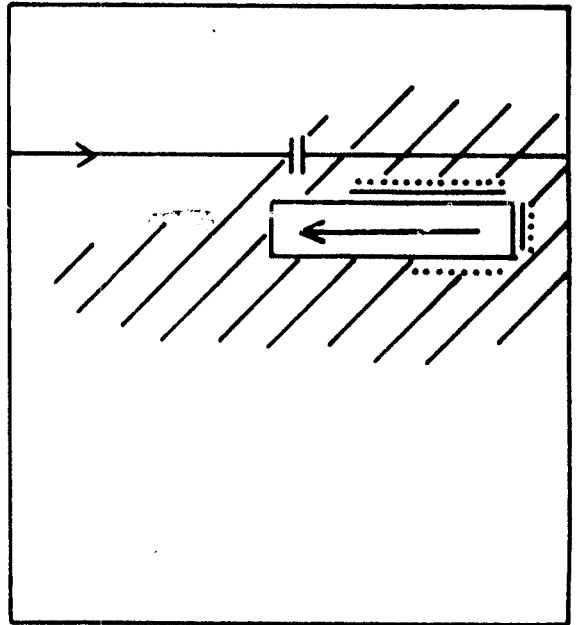

c 1900

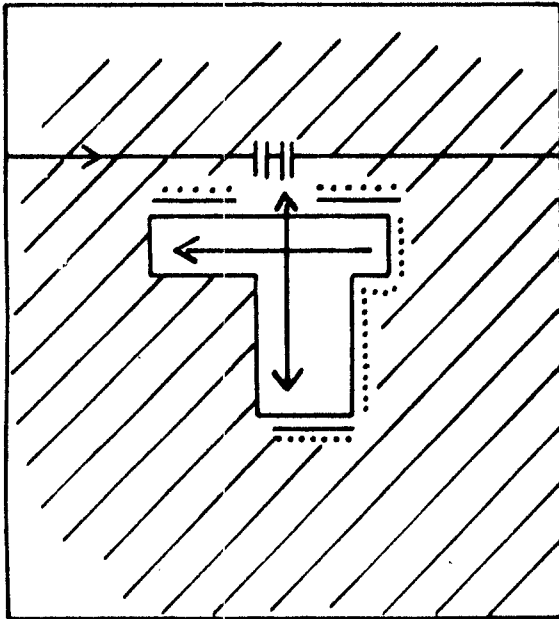

c 1950

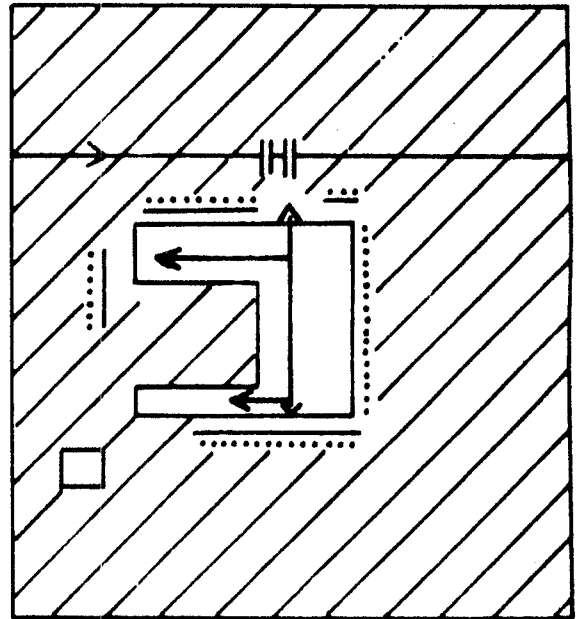

c 1975

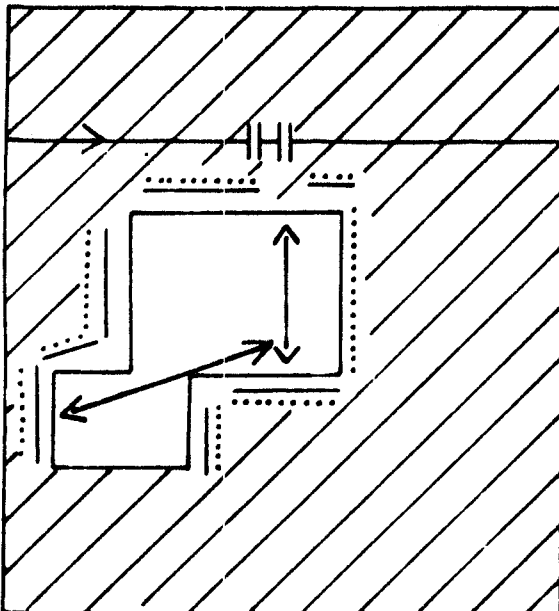

Key

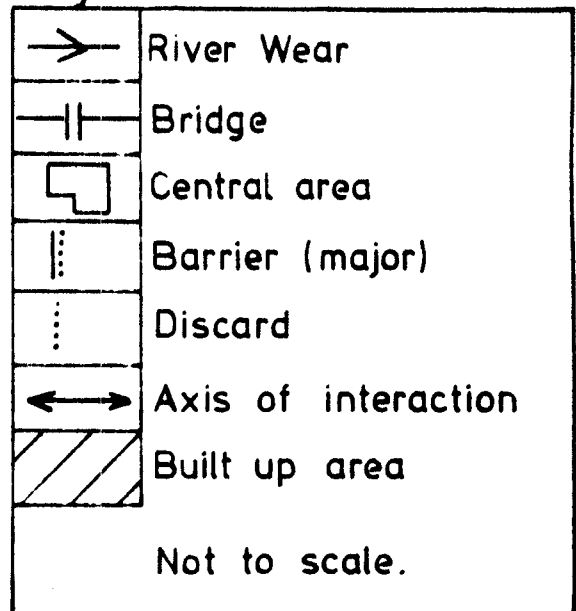

individuals, groups and institutions who have operated over the years in sometimes irrational ways and with imperfect knowledge.

The term 'spatial dynamics' has been adapted from another geographical context.<sup>(12)</sup> This concept is considered appropriate because it, more than alternative expressions,<sup>(13)</sup> succinctly incorporates emphasis on spatial aspects of process, structure and morphology in an historical dimension.

The term 'commercial activity' is likewise interpreted in a broad sense to give expression to those non-residential activities which now predominate in most central areas of British towns. It, therefore, includes (i) the retailing of goods, (ii) rendering of services; (iv) wholesaling of goods; (v) governmental business; and (vi) manufacturing of goods. Finally, the term 'central area' needs amplification. Although the contemporary commercial core of Sunderland can be delimited fairly precisely using accepted methods, its migratory nature dictated that the spatial framework had to be flexible. It, therefore, includes more than that area usually defined as C.B.D. (see Chapter 5) and covers a broader 'transitional' area of more mixed morphology.

#### Organisation of the thesis

The thesis is subdivided into three sections, into which the chapters fall, forming a logical sequence. Section A deals with theoretical and conceptual ideas relevant to the understanding of central area change in Sunderland. Chapter 1 provides a general critique of the literature and knowledge of commercial activity in central areas. Chapter 2 seeks to relate various conceptual perspectives pertinent to central area research to the case of Sunderland. By placing considerable emphasis on the theoretical base of central area change, it is hoped that some of the obvious problems of a single case study can be controlled.<sup>(14)</sup>

Section B contains the main methods and findings of the research programme, and each chapter is built out of some facet of the theory. The origins and spread of the commercial core of central Sunderland in the nineteenth century are traced in Chapter 3. Chapter 4 analyses the nature of land use succession at five distinct time periods between 1894 and 1975. In Chapter 5, the contemporary central area is delimited and its internal commercial structure outlined. Chapter 6 examines commercial establishments of the delimited area in terms of the pattern of births, deaths, relocations and stayers. Chapter 7 then investigates the spatial behaviour of these establishments by sampling their opinions and perceptions of the commercial potential of central Sunderland.

Finally, a short Section C contains Chapter 8 which outlines a working model of commercial change for central areas and summarises the main findings of this research project.

#### Operational procedures and problems

Several technical and conceptual difficulties arose during the course of the research. In organising the research programme, it was first necessary to identify the core theory relevant to this study. This involved incursions into most of the systematic fields of human geography, ecology, economics and several other disciplines. Next, it was necessary to define a meaningful spatial unit within which change could be monitored. The lack of comparable data over the allotted time span and the constantly shifting nature of central Sunderland were inherent operational problems. A further stage of the research procedure lay in the selection of methods of measuring spatial change. No significant refinements<sup>(15)</sup> of techniques are offered in this study but a variety are used including traditional field and cartographic methods as well as more modern quantitative methods.

Throughout the whole of the research project the dominant objective has been to use Sunderland as an empirical case and hopefully a contribute to making the conceptual framework of central area studies more powerful. If the variety of facts and ideas, which are systematised, classified and interrelated in the ensuing pages help to confirm theory<sup>(16)</sup>, shift emphases and redefine problems of central area analysis, the present writer will have achieved more than he intended.

#### References and end notes

- (1) Murphy, R.E. (1971). 'The Central Business District: A study in Urban Geography.' (Longmans).
- (2) For example: Murphy, R.E. and Vance, J.E. (1954). 'A Comparative Study of Nine Central Business Districts.' Economic Geography, Vol. 30, No. 4, October pp 301-336.
- (3) For example: Conzen, M.R.G. (1960). The Plan Analysis of an English City Centre. in K. Norburg (Ed.) Proceedings of the I.G.U. Symposium in Urban Geography, Lund University, pp 383-414.
- (4) Openshaw, S. (1974). 'A Theory of the Morphological and Functional Development of the Townscape in an Historical Context', Seminar Paper, No. 24, Department of Geography, University of Newcastle upon Tyne.
- (5) Robson, B.T. (1969). 'Urban Analysis: a study of city structure with special reference to Sunderland.' Cambridge University Press.
- (6) 'Pre-industrial' and 'Medieval' characteristics of towns are fully outlined in, for example, Sjoberg, G. (1960), The pre-industrial city: city: past and present (New York).

- (7) The increasing strength of economic factors is recognised by Vance, J.E. Land assignment practices in the pre-capitalist, capitalist and post-capitalist city. Economic Geography, Vol. 47, No. 2, April, pp. 101-120.
- (8) Lawton, R. (1972). 'An age of great cities.' Town Planning Review, Vol. 43, No. 3, July, pp 199-224.
- (9) The genetic approach in urban geography is outlined in: Taylor G. (1951), 'Geography in the Twentieth Century', Chapter XXI. Urban Geography p 524-527 and idem, (1942), 'Environment, Village and City: a genetic approach to urban geography, with some reference to possibilism.' Annals, Association of American Geographers, 32, March, p 49. Smith, P.J. and Bannon, M.J. (1970), 'The dimensions of change in the central area of Edmonton, 1946-1966, in W.R.D. Sewell and H.D. Foster, (Eds.) The Geographer and Society, (1970), Western Geographical Series, Vol. 1, Chapter 14, pp 184-199, provides an exception. They believe that the genetic approach is an important notion because it goes further than the mere chronological account of unique phenomena and involves general principles of stages of urban development; in short it provides a "Geographical theory of urban evolution" p 184.
- (10) In, for example, Bowling, H. (1969) some chapters on the history of Sunderland and Sunderland Structure Plan, a Survey Report, Mo. 1, Town Centre, 1970.
- (11) In 1971, the centroid was located on Chester Road, at the General Hospital; see Fig. 4 for the 1851, 1831 and 1800 centroids.
- (12) Pred, A.R. (1966) The spatial dynamics of the U.S. urban-industrial growth, 1800-1914: interpretative and theoretical essays (M.I.T. Press)
- (13) Alternative concepts/terms considered were: (a) 'Natural History' as in Johnson, E.S. (1941). The natural history of a Central Business District with particular reference to Chicago. Ph.D. thesis, University of Chicago. (b) 'Spatial Reorganisation' as in Janelle, D.G., (1969). 'Spatial reorganisation: a model and concept.' Annals of the Association of American Geographers Vol. 59, pp 348-364. (c) 'Spatial Evolution' as in Sargent, C.S., (1974). 'The spatial evolution of Greater Buenos Aires, Argentina, 1870-1930.' Centre for Latin American Studies, Arizona State University.
- (14) Also, according to Hudson, J.C. (1968). 'A location theory for rural settlement'. Annals of the Association of American Geographers, Vol. 59. pp 365-381, there may be little value in recognising spatial regularities unless there is some theoretical justification.
- (15) The techniques for presenting and processing change are surprisingly crude according to Lynch, K. (1972). 'What time is this place?' M.I.T., Cambridge, U.S.A.
- (16) For a discussion of the relationship of theory and fact see, Goode, W.G. and Hatt, P.K. (1952). 'Methods in social research' (McGraw-Hill.) p.7 et seq.

SECTION A. THEORY AND METHODOLOGYChapter 1A SURVEY OF RESEARCH LITERATURE ON CENTRAL AREASIntroduction

Published and unpublished work relating to the commercial activity town and city centres is voluminous. The present survey concentrated only on geographical studies of central business districts and central areas. The purpose of this chapter is to summarise the main research advances in these fields as a framework for later chapters.

The terms 'central business district' and 'central area' are not entirely synonymous. The former expression, commonly abbreviated C.B.D. is well known to geographers <sup>(1)</sup> and refers to the retail and office core of cities. The term 'central area' (C.A.) embraces not only these two functions but also "residual industrial enclaves and ... residential properties". <sup>(2)</sup> A central area, therefore, is usually of greater extent than the C.B.D. <sup>(3)</sup> which can be viewed as a "special part of a C.A. complex". <sup>(4)</sup> It is this broader interpretation which has been utilised for this study of Sunderland because it permits fuller investigation and is a more realistic study area. In the ensuing discussion, however, literature using both expressions has been surveyed. For convenience, it is presented in three sections:

- (a) Non-British literature
- (b) British literature
- (c) Other research relevant to central areas

Non-British literature

Non-British literature relating to commercial central areas has been dominated by American contributions. In particular, these have focused primarily on the C.B.D., although the surrounding transition zone claims attention. <sup>(5)</sup> In many studies they are viewed together.

The significance of the central business districts in academic literature was manifested in the so-called classical models of urban structure. Whilst propounding, in detail, different interpretations of city structure, the respective authors <sup>(6)</sup> of these models agreed that the whole urban system hinged on the C.B.D.

In the inter-war period, much of the interest in the centre of cities was incorporated in general studies of towns with the C.B.D. comprising one chapter or section, along with and equal weight to others.

Wilson's study of Detroit <sup>(7)</sup> and Schmid's study of Minneapolis and St. Paul <sup>(8)</sup> fit into the category. Of a rather different nature were Proudfoot's work on Philadelphia <sup>(9)</sup> and William-Olson's work on Stockholm. <sup>(10)</sup> These latter studies approached C.B.D.s from the point of view of their primary functions as retail cores of the respective cities.

More specific studies of C.B.D.s were quite rare, and tended to be long in description and short on conceptual ideas and methods of analyses. An exception was Johnson's investigation of Chicago <sup>(11)</sup> in which he traced the sequential emergence of Chicago's C.B.D. in relation to the general changes in its economy. As Chicago developed from a pure trading centre (1673-1847) into a commercial industrial town (1848-1890) and then into a metropolitan city (1891- ) so the size and internal structure of the C.B.D. changed. Although the techniques for measuring these changes were not well developed <sup>(12)</sup> and the various hypotheses largely untested, Johnson's work provides many classic ideas for researchers dealing with the complex inter-relations of C.B.D.'s over lengthy time spans.

In the early 1950's, geographical research of the C.B.D. was focused on methods of delimitation, one of which has been extensively adopted in many different studies. The Murphy-Vance method is discussed fully elsewhere. <sup>(13)</sup> Basically, it involved making a distinction between central and non-central business use. The land use on the floor of each lot in every city block within its central part was recorded and mapped. From these data, two critical ratios were calculated for each block: the Central Business Height Index (C.B.H.I.) and the Central Business Intensity Index (C.B.I.I.). <sup>(14)</sup> If the C.B.H.I. was 1 or more and the C.B.I.I. was 50 per cent or more, then a block was considered to fall within a C.B.D.

This method was applied to nine American cities <sup>(15)</sup> and found "practicable and realistic" (p.41), offering a "standardized technique" (p.40) for comparative purposes. Murphy and Vance's innovative method was also applied to seven Australian cities and African and Asian cities. <sup>(16)</sup> For one of these cities, a hard core of its C.B.D. was delimited <sup>(17)</sup> using the same kind of indices but higher values. All contiguous blocks with a C.B.H.I. of 4 or more and a C.B.I.I. of 80 per cent or more were included. Within this area, commercial activity was dominated by retailing and office activities. The cores of several European cities were also delimited and subdivided into 'hard core' and

and 'fringe areas' in other studies.<sup>(18)</sup>

In addition to delimitation procedures, research also focused upon the 'internal' structure of the C.B.D. One approach was proposed by the same authors who developed the delimitation method.<sup>(19)</sup> Here, land use was again considered the "most valuable and practicable" (p.24) basis for investigation. A series of concentric zones spaced at 100 yard intervals outwards from the Peak Land Value Intersection Point (P.L.V.I.P.) were drawn. Land use analysis were then made for each zone at different floor levels, thus summarising both horizontal and vertical changes in the C.B.D. Zone 1, nearest the P.L.V.I.P., was dominated by retailing, whilst the non-central business group was a "at a minimum" (p.34). With increasing distance outwards definite land use changes occurred with non-central business uses increasing to a maximum in Zone 4 and central business uses generally decreasing to a minimum in the same zone.

Towards the end of their research (pp. 41-44), Murphy, Vance and Epstein considered briefly the dynamic nature of C.B.D. boundaries. Dynamic aspects of central areas were stressed in Rannell's study of Philadelphia<sup>(20)</sup> which examined changing functional and morphological patterns in terms of individual establishments. But Murphy, Vance and Epstein focused their interests more on the differential rates of change at the C.B.D. edge and distinguished zones of assimilation (expansion) and zones of discord (contraction).

The phenomenon of the shifting C.B.D. received more attention in C.B.D. research in the 1960's. Mattingly<sup>(21)</sup> and Bohnert and Mattingly<sup>(22)</sup> showed how the Murphy-Vance method could be usefully employed at various movements of time as far back as the mid nineteenth century. Land use data were extracted from Sanborne Insurance maps.<sup>(23)</sup> Because these did not provide upper floor space data, Bohnert and Mattingly relied only on one index, the C.B.I.I., and suggest that percentages of 50 and 40 respectively for Harrisburg and the five Illinois cities gave an accurate representation of the spatial extent of the C.B.D.'s of these settlements over time. Bowden<sup>(24)</sup> in addition to the Sanborne maps, used city directories, photographs, sketches, newspapers and historical written descriptions to reconstruct the C.B.D. of San Francisco from 1850 onwards. He viewed the C.B.D. as a central place within a city system and demonstrated the operation of particular processes<sup>(25)</sup> in C.B.D. growth and shift. Ward<sup>(26)</sup> on

the other hand, did not specifically concern himself with delimitation but sought to describe and account for the nature and extent of commercial change in central Boston in terms of the impact of the industrial revolution.

The methods of study of C.B.D. change are thus varied <sup>(27)</sup> and still developing. Furthermore, according to Griffin and Preston, they need extending to incorporate spatial change in the wider central commercial area. <sup>(28)</sup> There is no doubt, however, that the American contribution to this facet of geographical enquiry has been considerable and that it is fundamental to understanding the British research effort.

### British literature

The C.A.s of British towns and cities are smaller and more heterogeneous <sup>(29)</sup> in terms of land use than their American counterparts. Statistics relating to them are also poor by American standards. Nevertheless, the C.A. has been the subject of study in a number of published and unpublished works in Britain. <sup>(30)</sup> Most of them have developed interesting modifications to suit the British context.

In a study of Nottingham, <sup>(31)</sup> Murphy and Vance's original division of land uses was modified to form three categories: viz, 'positive' (eg. shops and offices), 'neutral' (eg. warehouses, public buildings), and 'negative' (eg. residential and industrial). The C.B.D. of Nottingham was thus delimited on the basis of the land uses and correlated with rateable value data. Diamond <sup>(32)</sup> also delimited the C.B.D. of Glasgow using intensity and height indices but incorporated wholesaling into the central business use category on the grounds that it depended on "general contact" (p.528). A high correlation between central business land uses and land values was again established. Diamond concluded that central Glasgow was composed of three zones: a central zone with maximum land values and height of buildings; around this core area was a zone of greater commercial mix; firstly, there was the boundary zone in which central area functions no longer dominated.

In their study of the morphology of the C.B.D. of Cardiff, <sup>(33)</sup> Carter and Rowley preferred to define distinct functional (urban) regions, rather than zones. They also found land use data the "most satisfactory" (p.119) method of delimitation, but other criteria had to be used. The 'block' system was rejected. A greater emphasis

was placed on the emergence of Cardiff over time than in most other British studies, and site and historical factors were fully weighted.

Varying interpretation on the precise value of the indices to be used to delimit C.B.D.s are found in studies relating to a large number of British towns and cities. Mika <sup>(34)</sup> concluded that the Murphy-Vance method gave a "reasonable" (p.5) approximation of the C.B.D. of Derby, Norwich and Southampton. He went on to a standard analysis of the internal structure of each C.B.D. and concluded with a comparison of British and American C.B.D.s.

For Edinburgh, Taylor <sup>(35)</sup> who found the C.B.I.I. alone was adequate for approximating the C.B.D., claimed that the 10 per cent value was best for delimiting the larger central area. Bateman, <sup>(36)</sup> on the other hand, preferred 25 per cent as the limit of a C.A., and proceeded to show how urban renewal policies had been implemented in nine West-Riding towns. Varley's thesis <sup>(37)</sup> on Manchester had different emphasis, being concerned with describing land use regions and functional distributions by a variety of quantitative techniques. He did find however, that a C.B.I.I. of 80 per cent and a C.B.H.I. of 4 were critical in delimiting the C.B.D. of Manchester, although he considered the idea of boundary delimitation both "unreal and pointless" (p.98). Levein <sup>(38)</sup>, using individual boundaries as his unit, delimited the central area of a group of medium sized Scottish towns, by taking the critical value of 1 for a height index, (rejecting the C.B.I.I. as not valid). He also investigated the internal functional structure of the central areas in relation to such parameters as mean points, P.L.V.I. and C.A.M.P. (Central Area Mean Point). By relating land uses and land values a "clear spatial ordering was identified."

Some writers developed other approaches to C.A. study. Khan <sup>(39)</sup> did not develop delimitation techniques any further in the British context but sought to examine the changing factors which shaped the formation, emergence and growth of Coventry's C.A. Retail and office activities, as prime C.A. land uses, were selected for more detailed investigations. Thomas <sup>(40)</sup> even rejected the Murphy-Vance delimitation in favour of a new scalogram technique (pp.45-52). He identified certain spatial regularities in the internal structure of C.A.s., established a relationship between functional structure and city size, and coordinated contemporary knowledge in his comparative study of 12 C.A.s.

Despite Thomas's innovations, however, it is clear that much of the substantive geographical research of the British central city has been strongly influenced by non-British, and, in particular American research. Most studies have focused on methods of delimitation and investigation of internal structure, to such an extent that attention may be diverted from other 'priorities of study'.

Accordingly, increasing attention has been devoted to the concept of linkages in central areas. Linkages, in this context, may refer to the relationships of two or more functions or establishments in terms of producing flows of people, supplies and information, or to flows of other commodities. Linkages were implicit in Varley's study of Manchester which identified land use combinations and internal regionalisation of central London. <sup>(41)</sup> Whatever the particular slant <sup>(42)</sup> of linkage studies in central areas, it is clear that such processes do help to explain the genesis, spatial dynamics and commercial structure of central area.

#### Other literature relating to the understanding of the C.B.D. and C.A.

The foregoing survey of geographical literature on the C.B.D. and C.A. has concentrated only on a selection of specific case studies. In addition, an enormous range of other work exists which relates to C.A.s but which are often also concerned with other strands of geographical research. Two such sets of material were consulted and are briefly included here. These relate to; (a) morphological structure and (b) retail structure of urban areas.

#### Morphological structure:

According to Conzen <sup>(43)</sup>, geographical work on towns and cities has stressed functional rather than morphological aspects. With respect to the British C.A., therefore, he showed how a morphological approach is basic to the understanding of its evolution. In his analysis of Newcastle upon Tyne, he used three plan elements: the street, the plot and the individual building to meticulously reconstruct the structural evolution of its C.A. through time.

A stress on structural and morphological elements of C.A.s was also given by Bourne in his study of Toronto. <sup>(44)</sup> Like Conzen, he was concerned with the mechanics of structural change but in a contemporary rather than an historical context. Bourne considered, for example,

modern redevelopment of both land area and building space in the C.A.

The close relationships between physical morphology and functional change in towns were expressed in both studies. A way to achieve integration of the morphological and functional aspects of townscape in a historical context has been outlined recently. In a study of South Shields, <sup>(45)</sup> Openshaw sought to identify the origin, intensity and variability of various functional forces responsible for the operation of morphological processes over time. He viewed the central area as a place perpetually changing in a piecemeal manner under the impact of functional impulses and which was then modified in form by repletive infilling, adaptation, succession and other morphological processes.

#### Retail structure:

Other scholars restricted their investigations of C.A.s to particular aspects of their function at structure. Of these, retailing is perhaps the most popular, reflecting the dominant role of the C.A.s as the apex of the hierarchy in retail structure. Reference to several particular research studies will be made in later chapters. Here, only two specific contributions are considered.

Davies, <sup>(46)</sup> in 1972, how retail configurations, both empirically and theoretically, reflect existing settlement and land use models. By referring to the findings of Murphy and Vance and Horwood and Boyce, Davies devised a structural model of central area retailing facilities containing 'nucleated', 'ribbon' and 'special area' characteristics. The C.A. contained the more specialised retailing whilst the periphery exhibited more "complicated" retailing.

Whysall, <sup>(47)</sup> in a spatio-temporal study of the retail structure of Nottingham provides a practical illustration of retailing as a cogent element in C.A. change. The dynamic contexts of retailing in C.A. change were shown to encompass spatial, economic and social perspectives. The spatial distribution of retail establishments over time, which Whysall examined fully (Chapters 9-12) were seen as integral facets of general C.A. and urban change. He confirmed that the internal sorting of shops and retail site selection procedures are crucial components in the dynamics of C.A.s.

In other respects, too, importance of retailing in C.A. work has been conclusively demonstrated. Retail sales statistics have long been used to help on the delimitation of C.B.D.'s. <sup>(48)</sup> Also, as a generator of day-time movement, retailing is crucial in understanding activity patterns in C.A.'s. <sup>(49)</sup> Finally, long term trends of C.A.s have been based on retail sales and used in planning strategies. <sup>(50)</sup>

### Summary

The powerful influence of American and overseas research on C.B.D.s and C.A.s has been established; in particular, the contribution of Murphy and Vance can be traced in most empirical work in the past twenty years. The C.A.s of many British towns and cities have been studied by geographers, although much of the work has never been published. Useful additional research has been completed in more specialised fields, such as retailing, which has made valuable contributions to the understanding of the commercial structure of the C.A.

References and end-notes

1. Murphy, R.E. (1966). 'The American City: an urban geography, ' Chapter 15, 'The Central Business District' pp. 283-316 (McGraw-Hill) Idem, (1971), 'The Central Business District: a study in urban geography, (Longman)
2. Edwards, K.C. (1962). 'Trends in central area differentiation.' Proceedings of the I.G.U. Symposium in Urban Geography, Lund Studies in Geography, Series B, p519.
3. Incorporating the 'frame' of Horwood. E.M. and Boyce, R.R. (1959): Studies of the central business district and urban freeway development. University of Washington, Seattle, especially Section 1, and the 'zone in transition' of Preston, R.E. (1966). 'A Zone in Transition: a study of urban land use patterns. Economic Geography, Vol. 42, January, pp 236-260.
4. Carter, H. and Rowley, G. (1966). 'The Morphology of the Central Business District of Cardiff.' Papers and Transactions of the Institute of British Geographers, No. 38, June p.134.
5. The relationship between the C.B.D. and the Transition Zone in the central commercial area is expressed in Griffin, D.W. and Preston, R.E. (1968), 'Land use in the central commercial area'. Journal of Geography Vol. 42, January, pp 236-250. D.W. Griffin and R.E. Preston (1966), 'A restatement of the transition zone concept'. Annals of Association of American Geographers. Vol. 66 pp. 339-350.
6. Park, R.E., Burgess, E.W., and McKenzie, R.D. (1925). 'The City' pp. 47-62 (University of Chicago). Hoyt H. (1939) 'The structure and growth of residential neighbourhoods in American cities' (U.S. Federal Housing Administration, Washington, D.C.), and Harris, C.D. and Ullman, E.L., (1945), 'The nature of cities, Annals of the American Academy of Political and Social Science, Vol. 242, November, pp 7-17.
7. Wilson, L.S. (1936), 'Functional areas of Detroit, 1890-1933 Papers of the Michigan Academy of Science, Arts and Letters, Vol. XXii, pp 397-409. This work contains only a general study of the commercial core of Detroit.
8. Schmid, C.F. (1937), 'Social Saga of two cities: An ecological and statistical study of social trends in Minneapolis and St. Paul'. (Minneapolis Council of Social Agencies, Bureau of Social Research). of this work, only Chapter 2 especially focusses on the C.B.D. tracing its natural history, location and sequential development of urban functions.
9. Proudfoot, M.J. (1937), 'City retail structure'. Economic Geography, Vol. 13, pp. 425-428.
10. William-Ollson, W., (1940), 'Stockholm: its structure and development', Geographical Review, Vol. 30, pp. 420-438.
11. Johnson, E.S. (1941), 'The natural history of a central business district with particular reference to Chicago.' (Unpublished thesis. University of Chicago).
12. For example: The boundary of the C.B.D. of Chicago was defined simply according to the "commonly accepted definition."

13. Murphy, R.E. and Vance, J.E., Jr. (1954). 'Delimiting the C.B.D.' Economic Geography, Vol. 30, No. 3, July, pp. 189-222.
14. C.B.H.I. = central business space  $\div$  total ground floor area  
C.B.I.I. = central business space  $\div$  total floor space x 100
15. Murphy, R.E. and Vance, J.E., Jr. (1954), 'A comparative study of nine central business districts.' Economic Geography, 30, pp. 301-336.
16. For example: Scott, P. (1959). 'The Australian C.B.D.' Economic Geography, 35, No. 4, pp. 290-314; Davies, D. Hywel (1959), 'Boundary study as a tool in C.B.D. analysis: an interpretation of certain aspects of the boundary of Cape Town's central business district: Economic Geography, Vol. 35, No. 4 (October), pp. 322-345; Majid, R., (1970), 'The C.B.D. of Dacca', Oriental Geographer, Vol. 14 pp. 44-63. Davies, R.J. and Rajah, D.S. (1965) 'The Durban C.B.D.: boundary delimitation and racial dualism'. The South African Geographical Journal, 47, December, pp. 45-48. Young, B.S. (1961) 'Aspects of the central business District of Port Elizabeth, Cape Province. Journal of Social Research, Vol. 12, pp. 270-48. Marshall, C.E. (1959), 'The C.B.D. of Johannesburg', Proceedings of South African Institute of Town Planners, Vol. 52, pp. 60-67.
17. Davies, D.H. (1960), 'The hard core of Cape Town's central business district: an attempt at delimitation: Economic Geography, Vol. 36, pp. 64-69.
18. For West Germany see, Hartenstein, W. and Staak, G. (1967) 'Land use in the urban core', Part 1, pp. 35-52, in Heinemeijer, W.F., Van Hulten, M. and de Vreis Reilingh, H.D. (Eds.), 'Urban core and inner city, Proceedings of the International study week. (Amsterdam).
19. Murphy, R.E., Vance, J.E. (Jnr.) and Epstein, B.J. (1955), 'Internal structure of the C.B.D.' Economic Geography Vol. 31, pp. 21-46.
20. Ranelles, J. (1956), 'Core of the city,' (New York).
21. Mattingly, P.F. (1964): 'Delimitation and movement of C.B.D. boundaries through time: 'the Harrisburg example'. The Professional Geographer, Vol. 16, No. 6, November, pp. 9-13.
22. Bohnert, J.E. and Mattingly (1964). 'Delimitation of the C.B.D. through time'. Economic Geography, Vol. 40, pp. 337-347.
23. Sanbourne insurance maps and the American equivalent of the Chas. E. Goad maps used in Chapter 4 of this study. They show ground floor use, number of storeys and nature of building materials. Sanbourne maps were also used to delimit the C.B.D. of Mexico City in 1906. See Ross, S.H. (1971), 'The C.B.D. of Mexico City as indicated on the Sanbourne Maps of 1906'. Professional Geographer, Vol. 23, pp. 31-39.
24. Bowden, M.J., (1971), 'Down town through time: delimitation, expansion and internal growth'. Economic Geography, Vol. 47, No. 2, April, pp. 121-135.
25. The most important of these were: accretion, transformation (change-over of blocks from non-C.B.D. to C.B.D. uses), back-and in-filling, leapfrogging, separation, and sequence of reaction. (Bowden, 1971, pp. 129-131).

26. Ward, D. (1966), 'The industrial revolution and the emergence of Boston's central business district'. Economic Geography, Vol. 42, January, pp. 152-171.
27. For a brief resumé of possible methods, see Murphy, (1971), op.cit. pp. 167-168.
28. See footnote, p.29, Griffin, D.W. and Preston, R.E. (1968), op.cit.
29. Conclusions reached both by: Vance, J.B.L. (1958), 'The C.B.D. of the British city with special reference to Nottingham' Unpublished Ph.D. thesis, Clark University, Worcester, p. 212-3; and Mika, P.J. (1965)'. 'A comparative study of some English and American central business districts', Unpublished Ph.D. thesis, Clark University, Worcester. The English towns were: Derby, Southampton and Norwich.
30. The nature and scope of C.B.D. research in Britain is succinctly summarised in: Rowley, G. (1965), 'A note on C.B.D. research in the U.K.' Professional Geographer, Vol. XVII, No. 6, pp 15-16; and Carter, H. (1976), 'Urban Geography in Britain, 1945-75, in Clarke, J.I. and Pichemel, P. (Eds.), 'Human Geography in France and Britain'. Social Science Research Council, pp. 64-72.
31. Vance, J.E.L. (1958), op.cit., Chapter 2.
32. Diamond, D.R., (1962), 'The central business district of Glasgow'. Proceedings of the I.G.U. symposium in urban geography, Lund Studies in Geography (B), pp.525-534.
33. Carter, H. and Rowley, G. (1966), 'The morphology of the central business district of Cardiff', Transactions, Institute of British Geographers, No. 38, June, pp. 119-134.
34. Mika, P.K. (1965). 'op.cit'.
35. Taylor, W.G., (1967), 'Methods of central business district and central area delimitation'. Edinburgh School of Town and Country Planning.
36. Bateman, M. (1968), 'The nature and processes of urban renewal in the central areas of nine towns of West Yorkshire during the post-war period'. Unpublished Ph.D. thesis, University of Leeds (The nine towns were: Leeds, Huddersfield, Halifax, Harrogate, Bradford, Dewsbury, Wakefield, Castleford and Shipley).
37. Varley, R.A. (1968), 'Land use analysis in the city centre with special reference to Manchester'. Unpublished M.A. thesis, Aberystwyth University.
38. Levein, C.P.A. (1973), 'Delimitation and comparative analysis of the central areas of medium-sized towns in central Scotland'. Unpublished Ph.D. thesis, University of Edinburgh. (The towns were: Dunfermline, Falkirk, Hamilton, Ayr, Stirling, Kilmarnock, Kirkaldy, and Perth).
39. Khan, M.A. (1972), 'The growth and morphology of the central area of Coventry', (3 vols.), Unpublished Ph.D. thesis, Birmingham University.

40. Thomas, R.W. (1971), 'The comparative analysis of the British city central area. Unpublished Ph.D. thesis, University of Nottingham. (His 12 towns were: Birmingham, Manchester, Liverpool, Bristol, Cardiff, Derby, Gloucester, Huddersfield, Newport, Nottingham, Oldham).
41. Goddard, J. (1967), 'The internal structure of London's central area' in Heinemeijer, W.F., Van Hulton, M. and deVries Reilingh, H.D.(1967), Eds. Urban core and inner city. Proceedings of the International Study Week, pp. 118-140, Amsterdam (Leiden).
42. Goddard, J.B. (1970), 'Functional regions within the city centre: a study by factor analysis of taxi flows in central London'. Transactions, Institute of British Geographers, No. 49, pp. 161-182.  
Goddard, J.B. (1973), Office linkages and location, Progress in Planning (1) pp. 111-232.
43. Conzen, M.R.G. (1960), 'The plan, analysis of an English city centre', in K.Norberg (ed.), Proceedings of the I.G.U. symposium in Urban Geography, Lund, pp. 383-414.
44. Bourne, L.S. (1967), 'Private redevelopment of the central city: spatial processes of structural change in the city of Toronto'. Research Papers, No. 112, University of Chicago.
45. Openshaw, S. (1973), 'Processes in urban morphology with special reference to South Shields. Unpublished Ph.D. thesis, University of Newcastle.  
Also, idem. (1974). 'A theory of the morphological and functional development of the townscape in an historical context'. Seminar Paper No. 24, Department of Geography, University of Newcastle.
46. Davies, R.L. (1972), 'Structural models of retail distribution: analysis with settlement and land use theories; Transactions, Institute of British Geographers, No. 57, pp. 59-82.
47. Whysall, P. (1974), 'The changing pattern of retail structure of Greater Nottingham 1912-1971. Unpublished Ph.D. thesis, University of Nottingham.
48. Two examples are: (a) William-Ollson, W. (1940), op.cit. (b) Ratcliffe, R.V. (1953), 'The Madison central business area: a case study of functional change.' Wisconsin Commerce Papers, Vol. 1, No. 5, Bureau of Business Research and Services, University of Wisconsin, Madison.  
Foley, D.L. (1952), 'The daily movements of population into central business districts.' American Sociological Review, Vol. 17, pp.538-543.
49. Breese, G. (1949). 'The daytime population of the central business district of Chicago with particular reference to the factor of transportation.' University of Chicago Press. Also reprinted in 'Contributions to Urban Sociology' (Eds. E.W. Burgess and D.J. Bogue), Chapter 8, pp. 112-128.
50. McDonald, J.F. (1975), 'Some causes of the decline of central business district sales in Detroit.' Urban Studies, Vol.12. pp. 229-233.

## Chapter 2

### THEORETICAL BACKGROUND TO THE STUDY OF CENTRAL AREAS WITH PARTICULAR REFERENCE TO SUNDERLAND:

#### Introduction

From the survey of the relevant literature, it is evident that the central area is a complex association of activities, individuals and buildings resulting from intricate processes. Accordingly, the conceptual framework for this study is necessarily broad, embracing a diffuse body of theory applicable to urban spatial structure, functional specialisations and dynamics of urban change. C.A. change may stem from one or more of the following causes: population change, economic change, ageing of properties, transport developments and planning legislation. Their separate impacts are difficult to identify and explain in terms of theory. In each of the following sections an attempt will be made to highlight the perspectives most relevant for this study.

#### Economic perspectives

C.A.s are often the most important economic region in a town or city whether measured in terms of numbers employed, turnover or production. It is logical, therefore, to turn towards economic theory in the search for the understanding of the mechanics of C.A. change. A fruitful line of enquiry is provided by the combination of ideas of Myrdal<sup>(1)</sup> and Pred<sup>(2)</sup>.

Myrdal postulated the notion of cumulative causation whereby some area, due to an initial advantage (eg. centrality) attracts subsequent new activity and growth before less fortunate (eg. non-central areas). Pred viewed spatial change as self-sustaining by means of cumulative and circular mechanisms. The flow diagram in Fig. 2 illustrates a possible application and adaptation of these notions to central area change.

Implicit in this aggregate model is the assumption that each major input into the local economy generates a cumulative reaction effect on the central area. The input may take the form of an expansion of an export, or the birth of a new organisational activity. Once an area has established itself either by its advantageous location or greater size and gained some initial advantage, then the input generates a local multiplier effect in the form of new or expanded ancillary activities.

Fig. 2. A Model of Central Area Change (adapted from Myrdal and Pred)

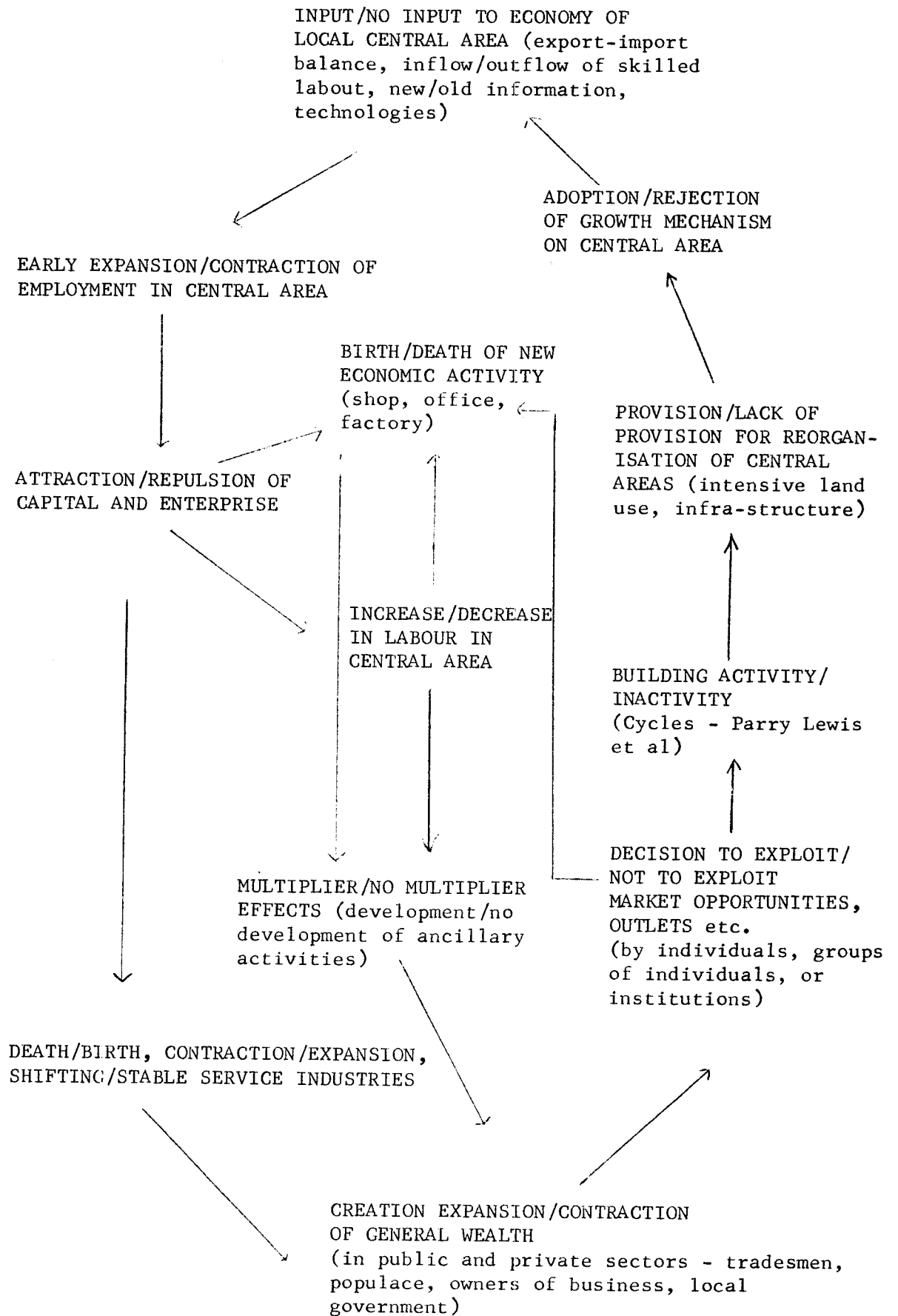

These are attracted to or near the same area in order to benefit from economies of scale, spatial propinquity and agglomeration. Thousands of individual decisions are made in this cumulative-circular process, each one depending on the perception and behavioural instincts of the individual, group or institution. A C.A. intensifies and expands by accretion so long as the locational factors remain favourable and so long as the total perceptual response is positive.

The growth component of the model portrays the complex process of central area development which accompanied the early urban-industrial growth of Sunderland. The model is certainly applicable during the nineteenth century, when the incipient C.A. was located in the past area. The export of coal mining was pivoted in the industrial urbanisation in Sunderland, its impact being diffused through the C.A. by (see Chapter 3) a complex series of linkages. A concentration of ancillary activities emerged which served these and other mercantile interests which were, for, Sunderland, primary sources of wealth.<sup>(3)</sup>

#### Population perspectives

Many researchers have related central area behaviour to the changing population characteristics of the surrounding market area on which it depends. It has long been established, for example, that a C.A. expands in relation to population growth and shifts in the direction of the centre of gravity of population and the higher income areas.

The relationships between C.A.'s and an expanding urban area are illustrated in Fig. 3 in two hypothetical cases. Case A shows a town which has expanded outwards in all directions so that the centre of the urban 'mass' remains fixed. The hub of this 'mass', the C.A., whilst expanding in response to urban growth, remains in the same location. A stable C.A. is considered normal in most American<sup>(5)</sup> and some Australian<sup>(6)</sup> African<sup>(7)</sup> and British<sup>(8)</sup> cities.

However, urban growth is often shaped by physical and human factors so that the outward expansion process is not uniform. In Fig. 3(B), the growth of a coastal town is hypothetically represented. Since growth can only occur on three sides, the C.A. tends to be 'pulled' in the direction of the population spread, i.e. away from the coast. This situation is clearly applicable in Sunderland where progressive westerly and southwesterly shifts of the commercial core has taken place over the last one hundred and fifty years.

### A. Hypothetical Inland Town.

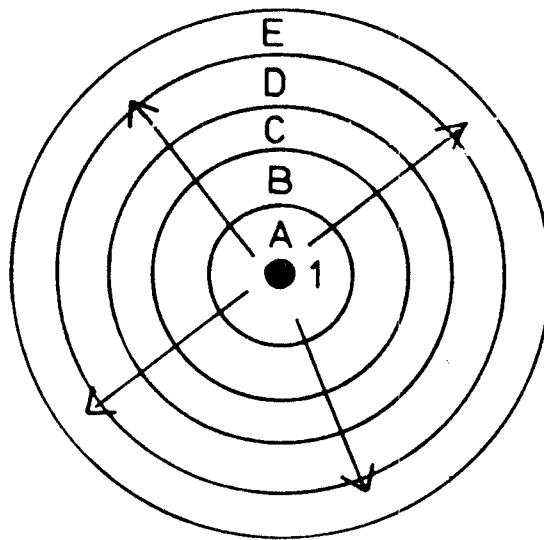

### B. Hypothetical Coastal Town.

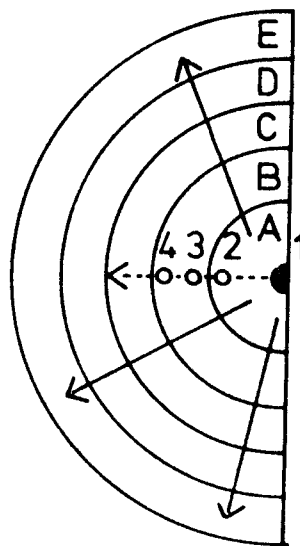

### Key.

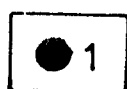

Original location of central area

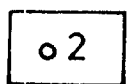

New locations

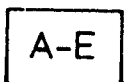

Urban growth zones

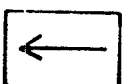

Direction of urban growth

### Ecological perspectives

One of the earliest theoretical perspectives into the spatial nature of towns was contributed by the ecological school. The Chicago urban sociologists redefined the principles of ecology in postulating a model of urban growth. The postulate was a concentric arrangement of land use around a central area (C.B.D.) into which those economic activities which could utilise the higher value land, greater accessibility and intensity of demand, would concentrate. Activities which were unable to adapt to this 'environment' of the central area located in outer zones.

At least three concepts inherent in the ecological approach are of theoretical significance in C.A. studies: first, expansion which brings about an extension or enlargement with increased complexity of structure; secondly, conversion, the change process by which one form succeeds or is substituted for another form; thirdly competition which certainly operates in a central area context, but in a hitherto unclear manner.

All three ideas are necessary underpinnings in the formulation of a theory for the spatial dynamics of central areas, and are used in ensuing chapters. The spread mechanism by which central activities 'filled-up' the spaces in Sunderland either by growth or diffusion is traced in Chapter 3. The succession of land uses in C.A. properties in Sunderland is studied in Chapter 4. Competition, the process by which individual operators, firms or functions hold their spaces, absorb smaller ones, or die, is examined in chapters 6 and 7. The notion of competition is a crucial one and deserves more attention.

Competition can be viewed as the outcome of two components but different processes: exploitation and interference. <sup>(9)</sup> The exploitation principle operates in a central area when a function draws upon a resource which is limited, such as a corner site or a High Street frontage. The more limited the space and the larger the number of functions requiring that resource, the greater the intensity of competition. The interference principle operates when there is conflict between different central area users. If interference becomes too strong then a user either 'dies' or 'moves'.

Theoretically, and in reality, these two principles produce four types of situations in central areas:

Situation 1: Two urban functions co-exist in space and time but exploit different central area space. For example, shops in High Street and warehouses in Villiers Street are physically separate with different locational attributes. This separation implies no competition.

Situation 2: Two central area users with different space demands and locational attributes may interfere with each other. Residential properties, for example, may be discouraged from locating anywhere near an unpleasant industrial concern.

Situation 3: Two different functions depend upon the same resource but co-exist without interference. A shop and an office occupy the same building for example, but the shop commands the ground floor and the office the upper floor. Competition exists but there is no interference.

Situation 4: The shop and the office utilise the same building but interference is present. Competition is intense and the outcome may be a shift.

These hypothetical situations are demonstrated in the contemporary C.A. of Sunderland in Chapter 6. Their testing in a historical sense is difficult due to data non-availability. Nevertheless, there is no doubt that ecological perspectives have been significant in the formulation of central area theory, and, in the case of Sunderland, Robson's treatise had unashamed ecological connotations.

#### Behavioural perspectives

There is evidence, however, that the driving mechanisms of the ecological processes may be waning. Accordingly, some C.A. researchers are shifting their emphasis from formal aspects of the ecological approach in which the simple morphological description of a changing state over time is stressed, to the examination of the decision-making behaviour involved in the development of C.A.'s. It would seem necessary in this new direction of analysis, which seeks to relate behavioural models to urban-economic location theory, to investigate the role of individual decisions. It is not yet clear how the geographer should cope with this slant. According to Pahl <sup>(10)</sup> it may be "more appropriate to understand the dynamics through game theory and conflict simulation"(p.13) although he admits that geographers do not know "how to weight the power elements in game," nor even "who all the players or actors are" (p.13).

Chapter 7 incorporates some elementary behavioural perspectives in the study of the nature and causes of commercial change in central Sunderland. The commercial landscape is viewed as the spatial dimension

of an urban/economic system which has been affected by countless decisions. The perception by business organisations of the commercial environment of the C.A. is a fundamental process about which "we know virtually nothing." (11)

### Classical geographical perspectives

Any realistic theoretical framework for central areas must include reference to several classical ideas, the most relevant of which are industrial location theory, land use theory and central place theory.

Classical industrial location theory in C.A.'s seeks to explain the spatial distribution of activities which serve the local or sub regional market and which depend on a complex of resources, linkages, market supplies and environmental considerations. The various approaches are related to economic theory and depend on a number of simplifying assumptions, namely cost minimisation and profit maximisation.

Classical land use theory is likewise based on economic considerations which regulate land use in urban areas. A key assumption is the ability of each activity to meet the rent of a site, so that a site is ultimately occupied by the most intensive use. (12) The land value surface reflects accessibility, to transport nets, information flows and friction of distance. Scholars agree that the central business activities concentrate in the area of peak land values. But the value of accessibility, depends on the activity: shops vary in their locational requirements; offices do also and, in addition, can operate in different locations than retail outlets; the same is true for residential and industrial activity.

Lastly, central place principles directly relate to urban commercial structure, (13) although at the intra-urban level, there have been theoretical advances on retail and services nucleations. The largest nucleation is, of course, the C.A. itself, which offers goods and services more numerous and of a higher quality than other centres in the same urban area. It relies on its accessibility and centrality to maintain its dominant position. Such a hierarchical arrangement of intra-urban retail/service clusters has long been recognised in the literature and substantiated by more recent research. Close inter-relationships and complex functional linkages occur between the commercial core and the surrounding centres. Also, changes in the

market demand, fashionability and potential produces readjustments in the location and structure of the central area. In brief, then it is the orderly sequence and the relative functional importance of C.A.s and other centres which is the concern of central place theory.

#### Planning perspectives (14)

In planning, the notion of hierarchy has provided a well established theoretical basis for the spatial organisation of urban centres, although recently, the organisation into hierarchical groupings has been questioned. (15) Since some discussion has already been given to central place, the impact of planning on central areas will be outlined with respect to three other questions.

Firstly, what is the ideal 'mix' of activities and the ideal degree of functional segregation which should be allowed in a central area? In some central areas, the construction of planned shopping precincts and office blocks is tending to encourage a clear cut separation of retailing and office activities. A tendency of grouping of particular activities has always existed in the modern C.A. and this could be achieved by deliberate planning measures to produce a more clearly marked functional differentiation within the central area itself. In other towns, new constructional activity has occurred in suburban or even out-of-town centres.

Secondly, how are central areas shaped by planning attitudes to public and private investments? Should central area development and redevelopment be comprehensive or piecemeal? How far do policies and strategies reflect natural forces and processes of central area change? New building stock alters the functional biases, land use distributions and activity patterns in central areas. More difficult to monitor is the prediction of space required in a changing central area and the balance between speculative property, owner-occupied and local authority development.

Thirdly, how do planning controls on movement in C.A.'s. affect commercial activity? Basically, planning can influence movement in central areas in at least five ways: by providing/restricting car parking; by re-routing vehicular traffic flows; by fixing transparent terminals, and stops; and by constructing pedestrian barriers. New foci of travel attract certain activities. Pedestrian accessibility is the key, (see Chapter 7) to the value of ground floor locations for retail and many office users.

The attitudes of authorities to these fundamental issues in central area planning can be gauged by sampling applications. Planning applications not only indicate the directions of development allowed but also the strength and efficacy of zonation legislation. Few empirical studies <sup>(16)</sup> exist, however, which develop the relationships between planning and C.A.

Summary

The problem of approach is a real one to the geographer studying the spatial dynamics of a C.A. over time. Should he resort to a deterministic normative approach and emphasise the models of ecology, land use rents, accessibility and central place? Or should he prefer a strongly probabilistic formulation based on the complexities of locational choice, space preferences and individual decisions? <sup>(17)</sup>

It would seem essential that, to understand the spatial dynamics of central Sunderland since 1800 the geographer needs to adopt a complementary standpoint. There ought to be an external spatial dimension involving shifting centroids, flows, linkages and changing patterns and an internal behavioural dimension incorporating new and old decisions and behaviour patterns. It is hoped that the obvious problems confronting a single case study can be met by maintaining a strong theoretical basis in the ensuing chapters.

References and end-notes

- (1) Myrdal, G.M. (1957), 'Economic Theory and Underdeveloped Regions' (London),
- (2) Pred, A.R. (1965), 'Industrialisation, initial advantage and American metropolitan growth'. Geographical Review, Vol. 55(2), pp. 158-185. Idem, (1966) 'Manufacturing in the American mercantile city, 1800-1840. Annals of the Association of American Geographers, Vol. 56, pp. 307-338.
- (3) The fundamental role of export industries as generators of urban growth was also propounded by Alexander, J.A. (1954). 'The basic/non basic concept'. Economic Geography, Vol. 30, pp. 246-261. The relationships between industrial and urban growth in the nineteenth century are developed further by: Sharpless, J.B. (1976), 'The economic structure of port cities in the mid-nineteenth century: Boston and Liverpool, 1840 - 1860'. Journal of Historical Geography, Vol. 2, No. 2, pp. 131-143.
- (4) Hoyt, H. (1939), 'The structure and growth of residential neighbourhoods in American cities', U.S. Federal Housing Administration, Washington D.C.
- (5) For example: Worcester. See Murphy, R.E., Vance, J.E. (Jnr.) and Epstein, B.J. (1955), 'Internal structure of the C.B.D.'. Economic Geography, Vol. 31, No. 1. (January) pp. 21-46.

- (6) For example: Brisbane. See Scott, P. (1959) 'The Australian C.B.D.' Economic Geography, Vol. 35, No. 4, (October), p.292.
- (7) For example: Cape Town. See Davies, D. Hywel, (1959), 'Boundary study as a tool in C.B.D. analysis: an interpretation of certain aspects of the boundary of Cape Towns central business district', Economic Geography, Vol. 35, No. 4, (October) p. 322.  
Also: Port Elizabeth. See Young, B.S. (1961), 'Aspects of the central business district of Port Elizabeth', Cape Province, Journal of Social Research, Vol. 12, pp. 27-48.
- (8) Mika, P.J. (1965), 'A comparative study of some English and American central business districts', Unpublished Ph.D. thesis, Clark Univ.
- (9) Hawley, A. (1950), 'Human ecology: a theory of community structure' (New York); Hagen, W.E. (1964), 'Readings in Population and Community Ecology', (London).
- (10) Pahl, R.E. (1968), 'Spatial structure and social structure', (Centre for Environmental Studies W.P. 10 (July). For further enunciation of the behavioural slant see: Pahl, R.E. (1970), Whose city,? and other essays on Sociology and planning. (Longmans).
- (11) Dicken, P. (1971), 'Some aspects of the decision making behaviour of business organisations, Economic Geography, Vol. 47, No. 3 (July) pp. 426-437.
- (12) Alonso, W. (1964), 'Location and land use', towards a general theory of rent'. Cambridge, Harvard University Press.
- (13) An interesting note on the relevance of central place theory and C.B.D.'s through time is: Murphy, P.E. (1970), 'A temporal study of the spatial adjustments of a C.B.D. in terms of central place principles: Tijdschrift voor Economische en Sociale Geographic, Vol. 61, Pt. 1, pp. 16-21.
- (14) For a discussion on perspectives of C.B.D. planning see: Durden, D. and Marble, D.F. (1970), 'The role of theory in C.B.D. planning', Journal of American Institute of Planning, pp. 10-16.
- (15) Minett, J.(1975) 'If the city is not a tree, nor is it a system', Planning Outlook, Vol. 16, (Spring), pp.4-18.
- (16) An exception is Davies, D. Hywell, (1960), 'Urban Geography and Planning in the C.B.D. of Cape Town'. South African Journal of Science, Vol. 56, No. 5,
- (17) For example, Pred. A.R. (1969), 'Behaviour and location', Lund Studies in Geography, Ser. B. Human Geography, No. 28.  
Dicken, P. (1971), op.cit.  
Also, a more specialised: Gorman, D.A. and Hitchcock, S.T. (1959), 'Characteristics of traffic entering and leaving the central business district', Public Roads, Vol. 30, No. 9, August, pp.213-220.

SECTION B. METHODS AND RESULTSChapter 3THE ORIGIN AND GROWTH IN SUNDERLAND DURING THE NINETEENTH CENTURYIntroduction

This chapter traces the spatial evolution of a C.A. in Sunderland and seeks to isolate some of the dynamic forces which shaped it. Although no specific dates are defined the formative period of the C.A. spans the nineteenth century; from a small incipient and functionally mixed area in 1800, it expanded, spread and consolidated into a modern central commercial area with functional segregations by 1900.

The data and information available to the geographer for this period in Sunderland are diverse and variable. No land use map is available; material relating to land use is scarce and of a secondary nature. Directories <sup>(1)</sup> are useful for certain years but tend to be weak on locational data, as well as containing inherent inaccuracies. <sup>(2)</sup> Newspapers <sup>(3)</sup> contain a mine of information but retrieval is laborious and time consuming. Rate books do not exist for the first half of the nineteenth century <sup>(4)</sup> and census returns are too general for detailed reconstruction before 1851. Occasional maps, prints, photographs, sketches and written accounts of streets, buildings and events are further sources of information.

Problems with the quantity and standardisation of data were, therefore, considerable. However, detailed cross-checking and pain-staking research of an archival nature have enabled the writer to identify the most significant spatial patterns and processes, and to test some of the theoretical assumptions prescribed in Chapter 2.

Economic stimuli of the C.A.

At the beginning of the nineteenth century there were three separate pre-urban nuclei in the study area. Monkwearmouth (1801 population: 1,103) on the north bank of the River Wear and Bishopwearmouth (1801 population: 6,126) on the south side of the river and further west, were small, agrarian settlements clustered around old established churches. Sunderland (1801 population: 12,412) <sup>(5)</sup> was of more recent origin and more populous due to its estuarine location, port trade and commercial importance. The straight-line distances between the centres of these three settlements were small. <sup>(6)</sup> Bishopwearmouth and Sunderland were connected by

High Street, much of which, in 1800, passed through agriculturally-used land; Sunderland and Monkwearmouth were linked directly by Bodlewell Lane ferry; and, 500 metres upstream, the first bridge crossing, opened in 1796, linked the north and south sides of the river. The coalescence of the three settlements into one single urban borough was strongly influenced by these river crossings <sup>(7)</sup> and the road network. The evolving C.A. was, in turn, influenced by the changing spatial relationships between the emerging urban area.

Urban coalescence was generated by growth mechanisms in the estuarine port area <sup>(8)</sup> on the south bank of the river. The relationship between industrialisation, urban growth and C.A. change is a complex one, although the important theoretical assumptions can be simplified (see Chapter 2). In the case of Sunderland, coal exporting provided the impetus to the cumulative/circular growth model. Coal exports rose progressively during the nineteenth century and particularly rapidly between 1800 and 1850. <sup>(9)</sup> In 1801, 280,000 chaldrons of coal were exported and by 1831, this figure had increased to 395,250 chaldrons. The railway boom of the 1830's opened up the coal producing region of inland Durham and focussed trade on selected ports. In Sunderland, extra coal handling facilities were built in 1815 (Lambton Drops) and 1822 (Hetton Staiths) to meet the greater tonnages exported.

Coal exporting also led to expansion in shipbuilding and all the ancillary miscellaneous trades. Shipbuilding, although suffering from more fluctuating fortunes, expanded in response to export demands. In 1801 the tonnage launched from Sunderland was 79,795; in 1851 it was only 51,833 but by 1871, and 1891, it was 81,903 and 188,715 tons respectively. <sup>(10)</sup> Linked to shipbuilding was the profusion of ancillary occupations such as carpenters, block makers, glaziers and painters who gained their employment from the source, and can be viewed as a direct multiplier effect.

The demand for skilled and unskilled labour in the port economy of Sunderland in the nineteenth century led to large inputs of immigrants. These people migrated from Scotland and Ireland and from the surrounding rural areas of North England. Together with natural increases in a youthful populace, they contributed to the rapid population increase associated with industrial nineteenth century towns. <sup>(11)</sup> Table 1 contains the actual population figures for 1801 to 1907 and Appendix 1 shows the rate of population growth compared to coal exports and

shipping launched. Like other nineteenth century industrial towns, Sunderland's population doubled between 1801 and 1841 and between 1841 and 1881. (12)

Table 1: The urban growth of Sunderland in the nineteenth century

Year	Population	Year	Population
1801	24,444	1861	78,211
1811	25,180	1871	98,242
1821	30,887	1881	116,542
1831	39,434	1891	131,015
1841	51,423	1901 *	146,077
1851	63,897	* Boundary extension	

(Source: Population registers 1801-1901)

The growth of population and the expansion of the local economy was obviously accompanied by constructional activity. The investment in port facilities and shipping, the growth of ancillary activities and the increase in population density created a demand for further building. The cyclical fluctuation on coal exports and shipbuilding in the nineteenth century were paralleled by similar trends in residential building activity. (13) By careful correlation of maps, it has been possible to reconstruct the spatial growth of building activity in the study area between 1800 and 1855.

The spatial growth process in Sunderland proceeded through accumulation and pressure at the centre and accretion at the edges. The centrifugal spread has been generalised in Fig. 4 which also locates the centres of gravity of population (14) for 1800 (A), 1830 (B) and 1855 (C). Between 1800 and 1855 the centroid had migrated over 400 metres from the intersection of Church Street and High Street East (A) to Coronation Street (C). The spread process was not significantly affected by topographic factors, although the growing town did have to negotiate a steep gradient which lay between the old port area and the plateau surface to the west which attracted better residential development. (Fig. 5.

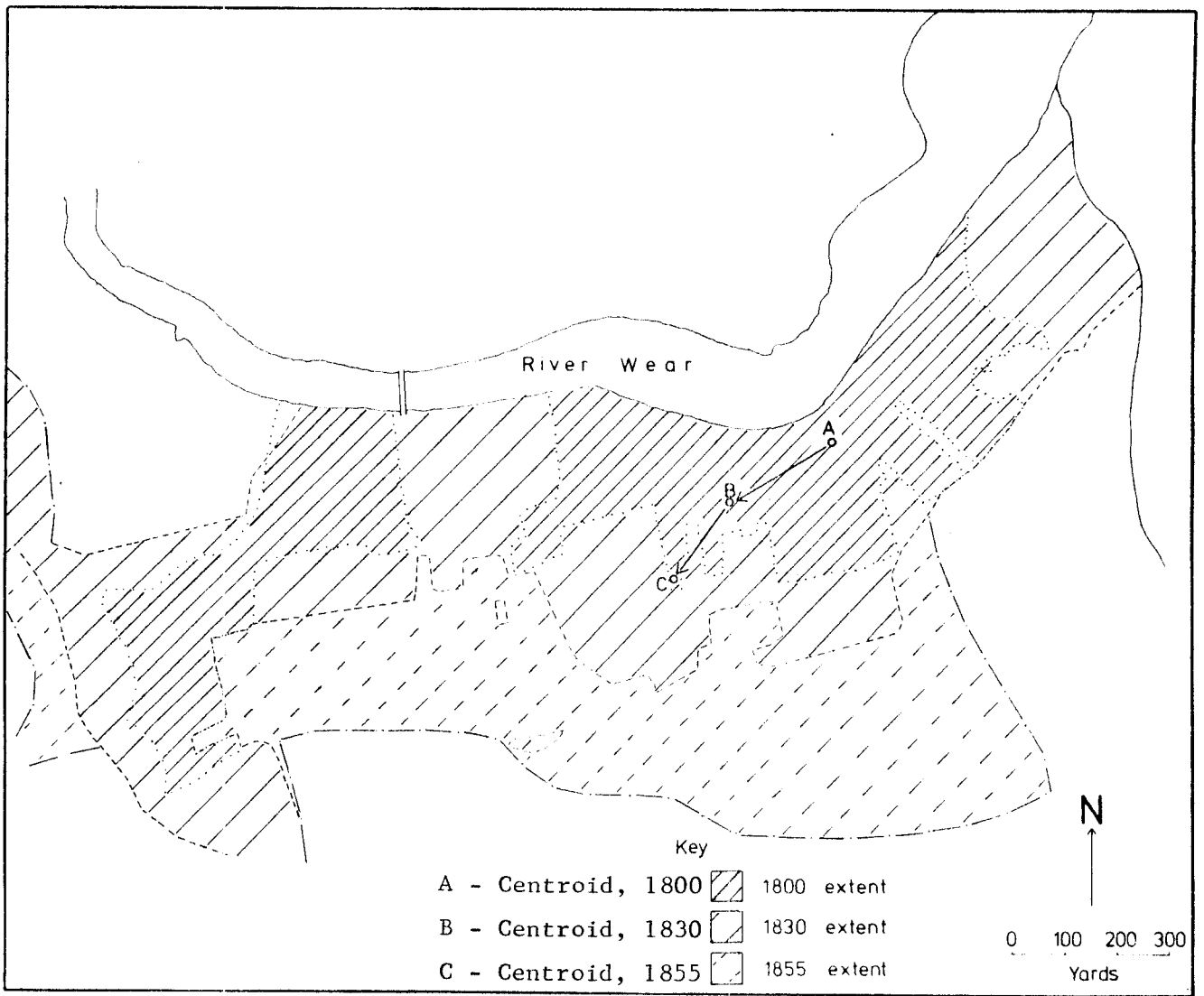

Fig. 4. A generalised map of urban spread and centres of gravity of population, 1800-1855. (see text).

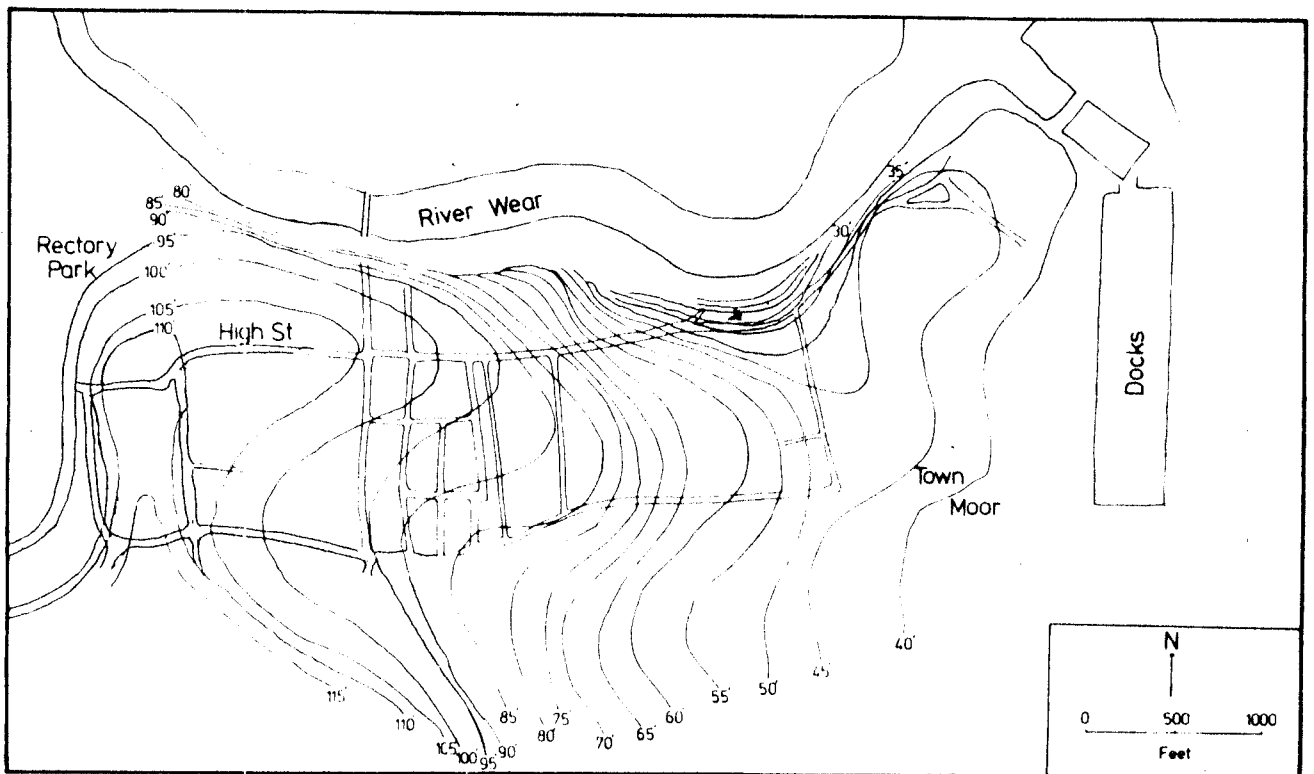

Fig. 5. Topographical factors in central Sunderland.

Morphological characteristics of the C.A.

The salient morphological features of this urban growth are identifiable from historical maps. Rains Eye Plan (Fig. 6) shows that, at the turn of the century, old Sunderland was a compact settlement confined within its parish boundaries. <sup>(15)</sup> Like many other mercantile cities, narrow steps led up from the dock area and Low Street to the broad east west thoroughfare of High Street. Streets running south from High Street to the Town Moor were interconnected by alleys, courtyards and squares. Open spaces still existed within this urban area such as Nesham's Ground at the eastern extremity of High Street, General Lambton's and Thornhill's grounds further west. West of Sans Street (parish boundary), open fields with occasional mansions and gardens were the rule until the village of Bishopwearmouth was reached, although some building had sprung up west of General Lambton's ground where the future Bridge Street was to be located.

The construction of the first bridge in 1796 increased the pressure on this central farmland area. In 1814, the Commissioner of the Bridge paid the landowner £500 to open-out a direct link from High Street to the bridge. <sup>(16)</sup> Garbutt's map of 1817 <sup>(17)</sup> shows the location of some new streets such as Villiers and Nile Streets, but as yet there was no Fawcett Street. (Appendix 2). Not until 1826 are the new streets of, for example, Foyle, Frederick, John and Fawcett Streets fully shown on existing maps <sup>(18)</sup> (Appendix 3). To the east of Fawcett Street, the street morphology was of the linear type <sup>(19)</sup> with terraces of varying lengths and widths depending on land ownership boundaries <sup>(20)</sup> and bye-laws. <sup>(21)</sup> To the west of Fawcett Street the street system was rectilinear. <sup>(22)</sup> By 1850 (see Appendices 4 & 5) the fields between Bishopwearmouth and old Sunderland were fully incorporated into the urban built-up area.

These street systems shaped the morphological and functional development of Sunderland. In both systems, patterns in their developments are observable. In the case of the terrace form, several stages existed: (a) the construction and lay-out of the intended street, (b) the building of the first few units of construction at one end of the terrace, (c) further additive building over the whole terrace but leaving undeveloped gaps, (d) infilling of the gaps, thus completing the morphological development. Fawcett Street followed this pattern: laid out in the mid 1820's, its plots gradually filled up with housing so that by 1844 (Appendix 4) it was exclusively built up apart from the

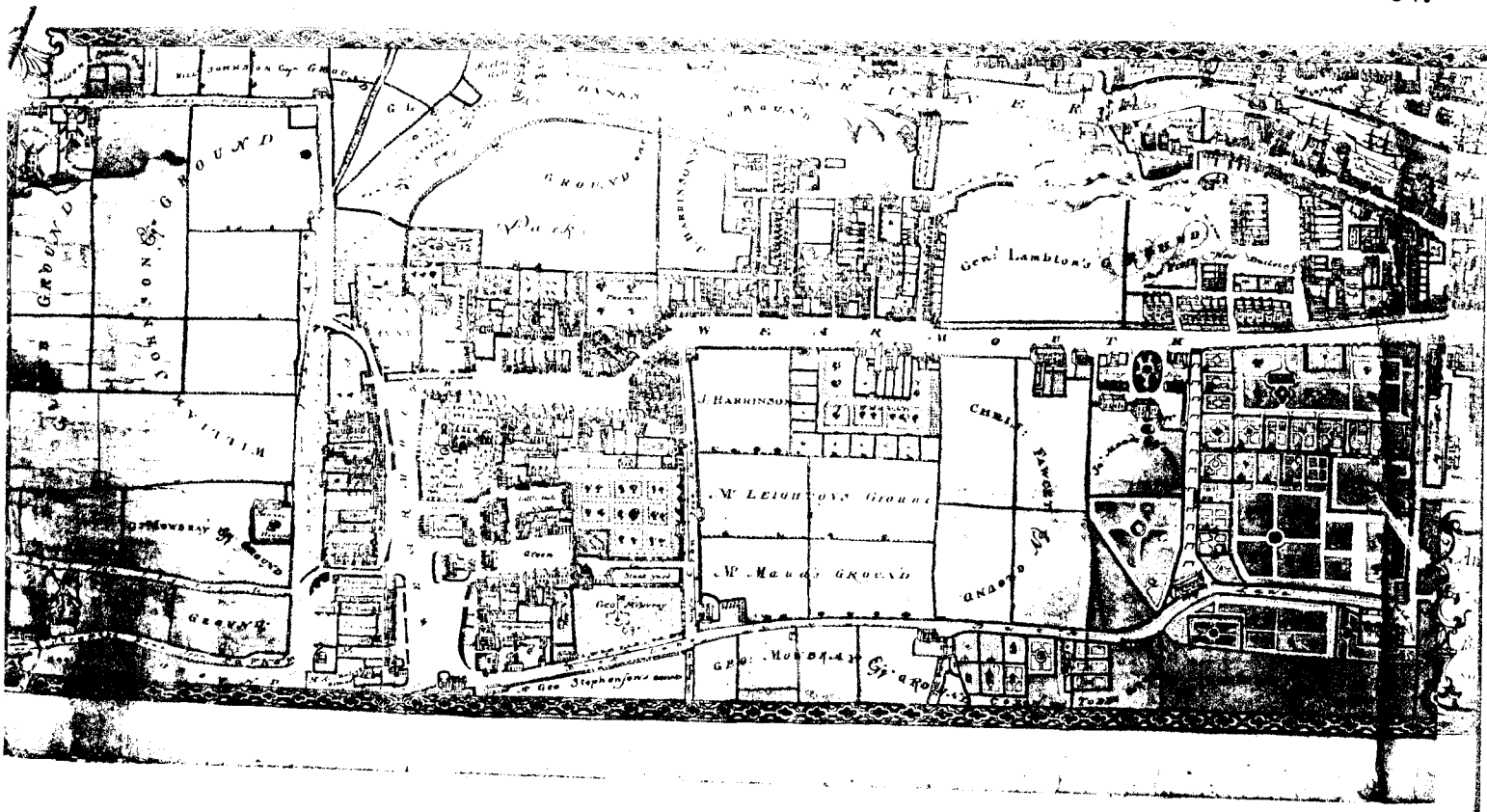
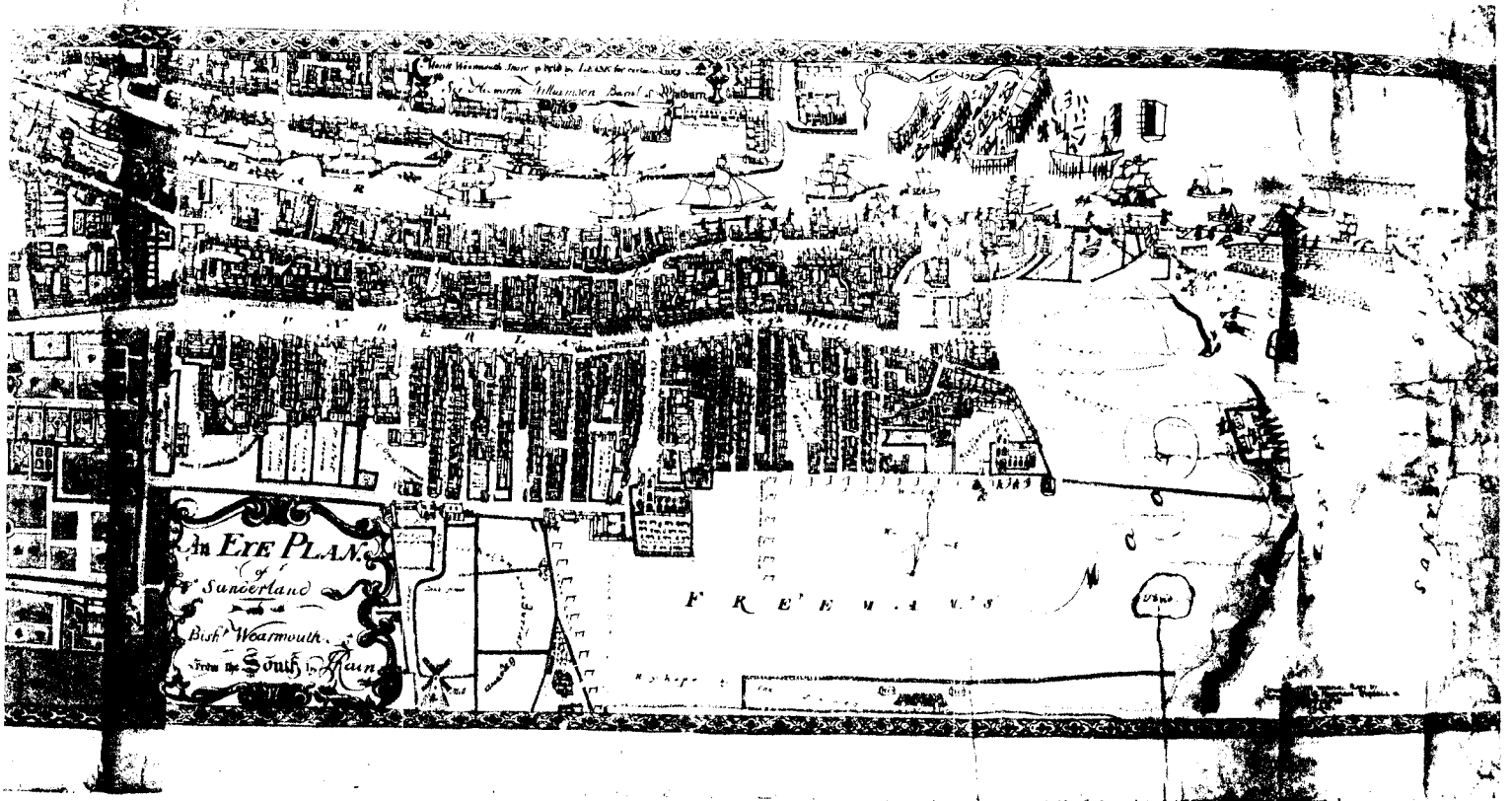

Fig. 6. Rains Eye Plan of Sunderland.



shrubbery which lay from Station Street to Barclay's Bank. This, was later infilled with the Town Hall and Library towards the end of the nineteenth century.

In the case of the rectilinear street form, a different model of morphological development can be postulated (see Fig. 7). Within the area bounded by High Street West, North Street, and, for example, new building located initially on the corner sites where double frontages gave advantages. Lateral building followed which produced a central space of yards etc. Later infilling and extensions backwards could produce a fully developed site.

While first phase residential construction was taking place in these newly, laid-out streets, second or even third phase construction was in progress in the old eastern parts. The rapidly increasing population put pressure not only on the open spaces such as Nesham's Ground which had, by 1827, been built on, but also on old poorer residential streets which were demolished and replaced by newer but smaller properties to accommodate more people. (23)

Thus, the process of urban growth in Sunderland has been characterised by outward growth street by street, on the one hand, intensification and infilling within the existing built-up area on the other hand. However, morphological development operates through functional forces to help shape the complex structure and behaviour of a C.A. (24) The next section attempts to relate the functional emergence of a C.A. in Sunderland to its morphological evolution.

#### Functional characteristics of the early C.A.

The functional structure of Sunderland developed in relation to the morphological framework outlined above. The spread and coalescence of Sunderland, Bishopwearmouth and Monkwearmouth into one continuously built up municipal borough (in 1835) provided the necessary stimuli for the origin and emergence of a commercial core. By extracting relevant information from rate books, census returns, directories, maps, photographs and other miscellaneous sources, it is possible to accurately reconstruct the nature and extent of the functional structure of nineteenth century Sunderland.

With nearly two-thirds of the population of the urban area and the strong linkage with the port economy it is not surprising that the incipient commercial core had its origins in Old Sunderland.

Fig. 7. A model of morphological development in street blocks.

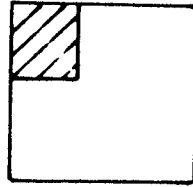

(a) Corner site occupation with double frontage.

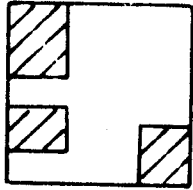

(b) Other corner site occupation.

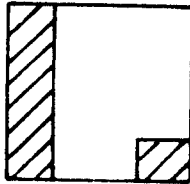

(c) Interconnections between corner sites.

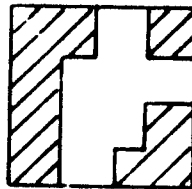

(d) All corner sites occupied and further lateral expansion.

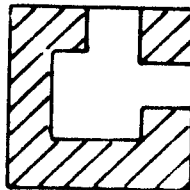

(e) Further frontage development.

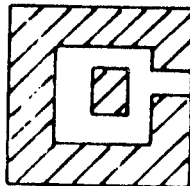

(f) Beginning of infilling.

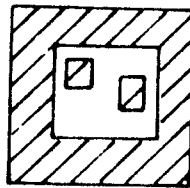

(g) Complete development of frontages and further infilling.

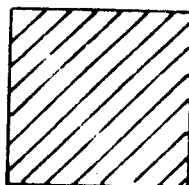

(h) Complete morphological development.

A most valuable starting point is provided by Rains Eye Plan. Despite its inherent weaknesses and inaccuracies, it yields, under microscopic inspection, great detail about the early commercial core. The pivot of this core was located on High Street East at the point where Bodlewell Lane ran down to Low Street. On High Street, were the main stall markets and itinerant traders. Permanent retail outlets were strung out along High Street as far east as Church Street and as far west as Russell Street. Immediately south of High Street lay residential property. To the north, squeezed between High Street and the river lay Low Street, a congested and dense street with a large number of low order shops, public houses and workshops. Numerically, Low and High Streets contained equal numbers of commercial concerns, but bigger better frontages on High Street suggest superior commercial quality. Furthermore, hatters, milliners and jewellers were found only on High Street, while Low Street had more grocers, bakers and other convenience shops.

Fig. 8(A) identifies the main characteristics of the spatial extent and nature of the C.A. as determined by the Eye Plan.

Key for Fig. 8(A)

1. Jeweller	.	Other shops
2. Mercer	☒	Institutions eg. Schools, Churches etc.
3. Grocer	*	Brewery
4. Inn	X	Slaughter-house
5. Saddler	⊙	Stable and Coach-house
6. Baker	X	Butcher's Market
7. Smiths	O	Bakers Market
8. Stationery/Printing	BB	Boat-builder
9. Ironmonger	BM	Block-maker
10. Hatter	☛	Fish-quay
11. Milliner	△	Bakery
12. Shoes	Sh.B.	Shipbuilder
13. Butcher	R	Raff-yard

The commercial core of Sunderland remained in this part of High Street East for the first few decades of the nineteenth century. The natural locational advantages of High Street for commerce were confirmed by a corporate decision taken in 1809 to build a town hall at

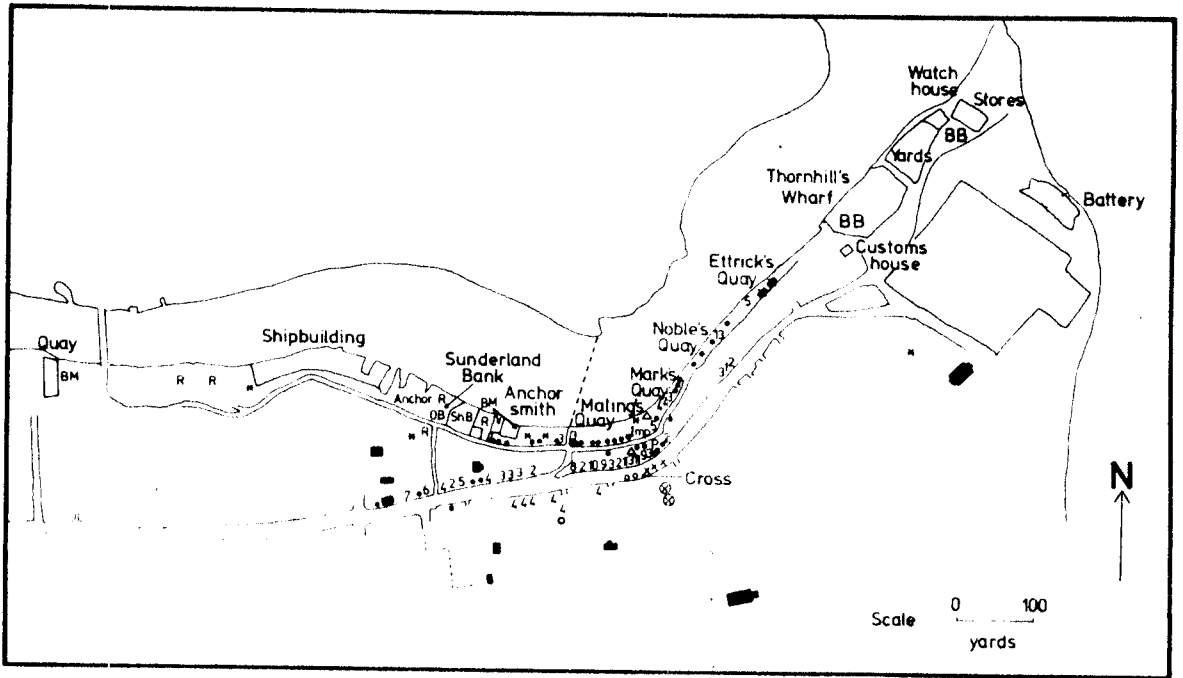

B. 1830

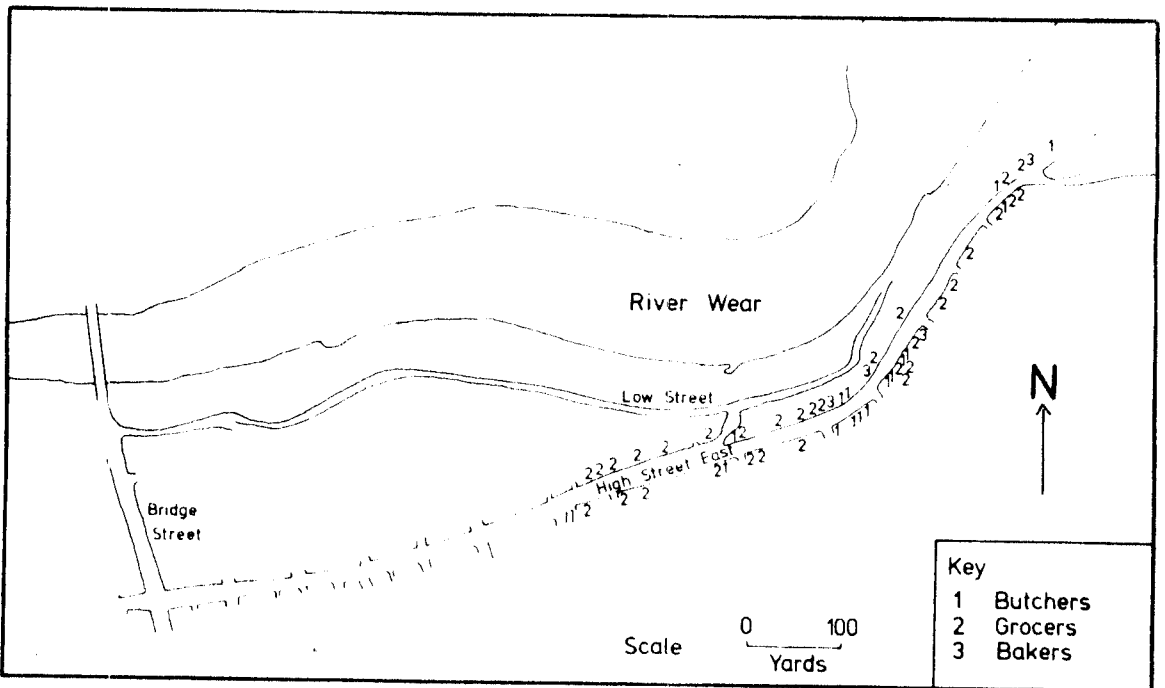

C. 1850

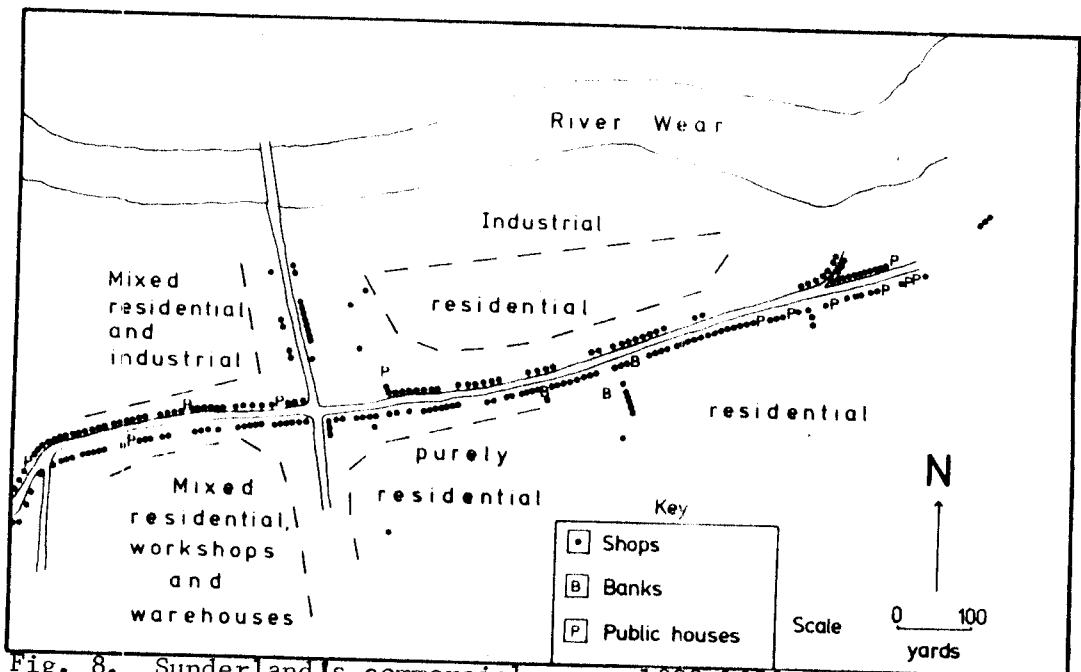

Fig. 8. Sunderland's commercial core, 1800-1850.

197, High Street East. This was built by private enterprise to accommodate local administration, post office, insurance, magistrates and commissioners office space. It was in public use in 1814 and was first portrayed in Garbutt's map of 1817. The new town hall, in the eyes of inhabitants, was "the centre" of Sunderland. (25)

A second aspect of central area emergence involved the removal of wholesale and retail markets from High Street where congestion and insanitation were considered excessive. (26) The new market was relocated further east in Lombard Street which ran south from High Street and opened eventually in 1826. The separation of a distinct retail market under the Improvement Acts of 1809 and 1826 were the first example of the effect of corporate planning decisions on the shape and structure of a central area in Sunderland.

The continuing outward growth of Sunderland was paralleled by increasing commercial concentration at the centre. By 1830, the extent of the C.A. and the number of commercial occupants, had increased considerably. Table 2 contains a detailed classification of the frequency of commercial trades in High and Low Street in 1831. Nearly 90 per cent of the separately listed trades for these two main streets were located on High Street. Low Street had declined relatively. Food trades had virtually disappeared and there was a strong representation of craftsmen's shops specialising in such activities as leather, metal and wood working, many of which preferred locations within the proximity of the river. Table 2 shows the distribution of Fig. 8 (B) three food trades which can be precisely located from Burnett's directory. (27) The parish boundary to the west, effectively limited commercial growth in that direction. To the east, however, a continuous string of retail outlets stretched as far as Barrack Street. Anomalously, this C.A. expansion was away from the natural westward spread of Sunderland.

The westwards migration of the C.A. of Sunderland along High Street increased rapidly after 1830. The incorporation of Bishopwearmouth and Sunderland parishes into one Municipal Borough in 1835, the construction of new streets (Fawcett, John, etc.) and the environmental problems of the old east end all contributed to the demand for commercial space in High Street West.

Table 2: Classification of commercial activity in HIGH and LOW STREETS IN 1831. (J. Burnett: Directory for the Parishes of Sunderland, Bishopwearmouth and Monkwearmouth).

<u>TRADES</u>	<u>NUMBERS</u>	
	<u>High Street</u>	<u>Low Street</u>
A. <u>Books &amp; Stationery</u>		
Stationers - retail	1	-
Printer	6	-
B. <u>Chemists &amp; Druggists</u>		
Chemists and Druggists	12	-
C. <u>Cloth and Clothing</u>		
Boot and Shoe makers	9	1
Milliners	1	
Tailors	2	2
Linen and Woollen Drapers	20	1
Hosiers	2	
Hatters	8	
Haberdashers	8	
D. <u>Pottery</u>		
China, Glass, Earthenware	2	3
Earthenware		1
E. <u>Food Trades</u>		
Bakers	8	1
Confectioners	3	
Grocers	54	2
Butchers	20	
Fruiterer		1
Greengrocer		
Bacon and Ham Dealers	4	
Flour Dealer	2	
F. <u>Metal Goods Trades</u>		
Cutlers		1
Ironmongers	2	1
Silversmiths	1	
Clock & Watchmaker & Gunsmith	3	2
Gunsmith	1	
Blacksmith	1	
Chainmaker	2	
Whitesmith		1
G. <u>Leather Trades</u>		
Leather dressers/cutters	1	
Saddlers	3	
Curriers		1

	<u>Numbers</u>	
	<u>High Street</u>	<u>Low Street</u>
H. <u>Furniture</u>		
Cabinet Makers	3	
Joiner	4	
Upholsterer	3	
I. <u>Beverages</u>		
Publican	24	3
Spirit Merchant	12	1
Brewer	3	2
J. <u>Professional Services</u>		
Banker	2	
Solicitor	8	
Doctor	1	
Surgeon	10	
Ship Inspector	1	
Land Surveyor	1	
K. <u>Shipping</u>		
Shipbuilder	2	
Wharfinger	1	
Blockmaker	3	
Compass Maker	1	
Ship Chandler	2	
Sailmaker	6	
Canvass Dealer	2	
Marine Stores	4	
L. <u>Miscellaneous</u>		
Tobacconists and Cigar Dealers	1	1
Tallow Chandler	4	
Brazier	4	6
Hairdresser	1	1
Mason	1	
Gardener	1	
Slater	1	
Painter	3	2
Coalfitter	2	1
Toy Wharehouse	1	
Lady	3	
Gentleman	6	
Shipowner	3	
Eating House	1	1
Timber Merchant		1
Cooper		1
	<u>301</u>	<u>40</u>

Evidence of the negative factors discouraging commercial growth in the older part of Sunderland is conclusive if somewhat fragmentary. The advent of the railway and expansion of dock facilities encouraged industrial rather than commercial activities. <sup>(28)</sup> The disease, cholera and uncleanliness <sup>(29)</sup> of the poorer inhabitants whose distribution was concentrated in the eastern areas, <sup>(30)</sup> became powerful factors in the first half of the nineteenth century. Distasteful practices and leisure pursuits, <sup>(31)</sup> also contributed to the environmental run down. The deterioration of the urban environment of Sunderland is recorded in a Government Report of 1843 which comments on the high density of housing, lack of sanitation and the intermixture of polluting industry and residential areas.

The migration of commercial activity was becoming more apparent. At first, banks were leaders in the shifting process in High Street. For example, banking in its early days in Sunderland, was located in the houses of the wealthy in Golden Alley and Maud's Lane. <sup>(32)</sup> Probably the first institutional bank in Sunderland was located in High Street West at the intersection with West Sunnyside and was operational in 1831. <sup>(33)</sup> Other banks, similarly established themselves in better business locations in High Street West, accessible to high class streets.

The period 1830-50, therefore, was a period of particularly active commercial change. Fig. 8 (C) shows that by 1850 the C.A. of Sunderland was at its maximum elongation. Shops, banks and offices stretched from Crowtree Road in the west to Church street in the east. Apart from Bridge Street where the construction of the bridge had attracted business, there was little commercial activity away from High Street.

The rate book of 1850 and the census of 1851 are useful sources for the reconstruction of a C.A. for this period. The former source permits land uses to be related to land values; the latter gives greater details on the population structure of a mid-Victorian C.A. in relation to land uses. Although neither source gives details of the number or size of commercial establishments, the geographical nature of the C.A. is definable.

It is clear that, like other mid-Victorian industrial/mercantile towns, <sup>(34)</sup> the C.A. of Sunderland was of mixed land use, with retail, office, workshop space intermingling with residential uses. Offices were located on either ground floor or possibly first floors of merchants' houses and shops were usually front rooms with enlarged window openings. Warehousing was largely carried out in cellars and out-buildings. The shipbrokers, agents and merchants - prime capital accumulators - operated from the more fashionable residential streets south of High

eg. Villiers and Norfolk Street. Fixed shops were beginning to command highly rated sites where the growing urban middle class sought improved shopping facilities. (35)

Land values (36) and commercial change

Constructional activity went hand in hand with climbing land values in Sunderland. The new street network, the rapidly rising population and the distribution of high class residential areas conferred locational advantages on western areas at the expense of older, more congested eastern quarters.

Valuation records are used widely in geographical studies of the urban anatomy. (37) The first available tabulation of Sunderland property values is for 1838 (38) and covers only the old riverine parish. For both old Sunderland and Bishopwearmouth parishes, the 1850 Rate Book gives fuller coverage at a time when the central area was beginning to shift radically.

Valuation lists for the second half of the nineteenth century can be used to trace the shifting commercial base of central Sunderland. The changing commercial fashionability of High Street and those streets leading from it both reflected and caused changes in the spatial distribution of property values. The 1838 rate book, although applying only to the old Sunderland parish, is valuable in terms of functional analysis (Appendix 6) The 1850 rate book contains similar information for both Sunderland and Bishopwearmouth parishes and is, therefore, of greater value in showing land value gradients in the emerging C.A. Appendix 7 gives details of streets in Bishopwearmouth parish which are pertinent to this study.

The peak land value in 1850 in Sunderland lay at the intersection of John Street and High Street West (Fig. 9) Values had risen in this area on account of the locational advantages associated with high class housing and bridging of the river which conferred nodality on this part of Sunderland. A core of high values is centred on or near High Street itself. Upper, mid- and lower quartiles have been drawn to show the gradient of land values away from the Peak Land Value Intersection. (P.L.V.I.). These 'isovals' (39) are constructed from control points which are fixed at mid points of the various streets and which represent 'means' of the values of all properties in each street. As the map shows, the land values declined gradually away both

# 1850

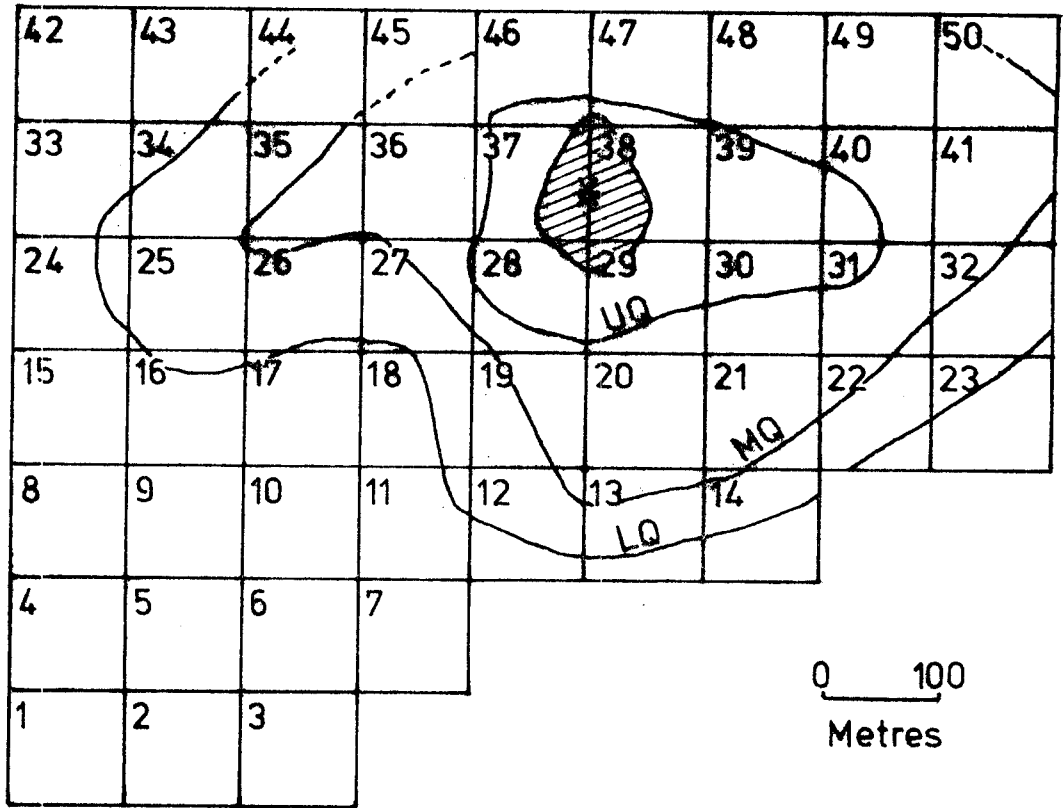

# 1901

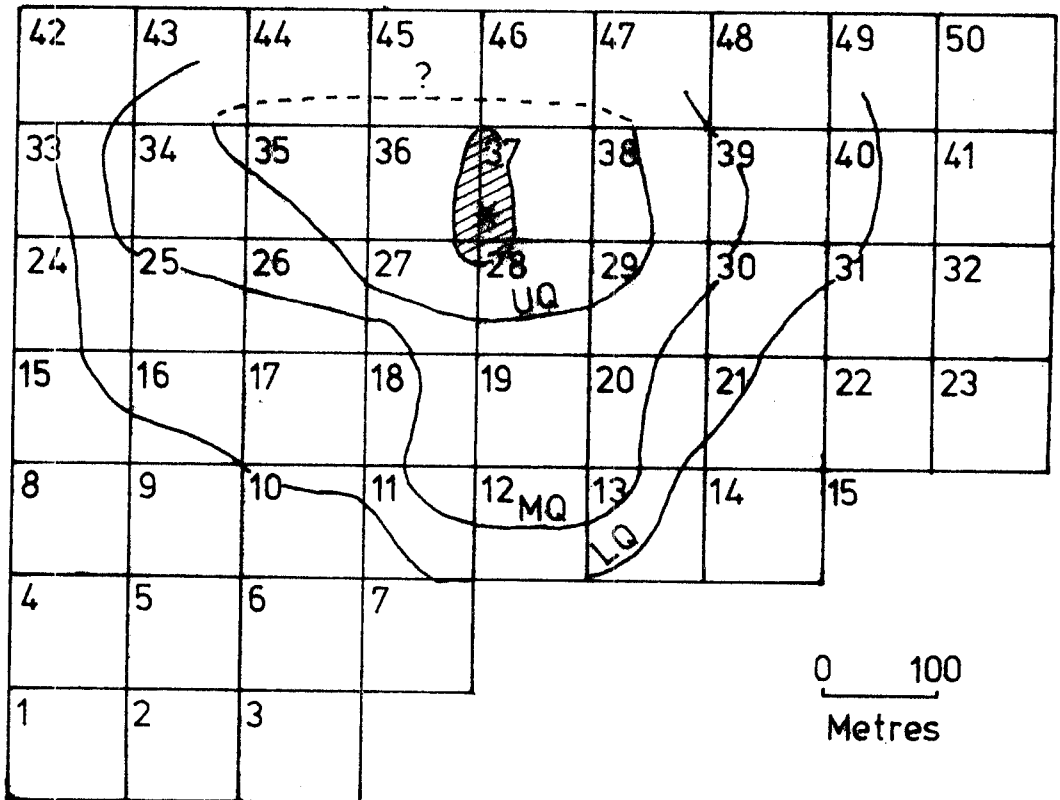

Key

- UQ Upper Quartile
- MQ Middle Quartile
- LQ Lower Quartile

-  Core of highest values
- \* P.L.V.I.

Fig. 9. Land values in central Sunderland, 1850-1901.

in an easterly and westerly direction with isovals reflecting the alignment of High Street. An extension of high values stretches south along Fawcett, John and Frederick Streets. Northward and south-westward, however, land value gradients slope steeply reflecting the proximity of the river and poorer quality properties respectively. The distribution of higher values is associated at this stage with better residential buildings rather than commercial properties.

Comparing valuation lists for different years, has, despite inherent difficulties, been employed with great effect with Sunderland<sup>(40)</sup> and other towns.<sup>(41)</sup> Fig. 9(b) portrays the spatial distribution of property values at the end of the nineteenth century using the same recommended<sup>(42)</sup> quartile subdivision. Two spatial changes can be identified: firstly, the P.L.V.I. shifted 100 metres to the intersection of Fawcett Street and High Street between 1850 and 1901. Secondly, a significant reshaping of the property values took place. Property gradients to the east along High Street drop steeply due to the obsolescence and further decay of the older parts. Similar steep gradients exist to the north where expansion of industrial, warehouse and other non-retail uses precluded high value commercial development. To the south, however, anchored on Fawcett Street, substantial increase in property values can be observed.

The 1870-1890 period marks another period of active commercial expansion or "burst"<sup>(43)</sup> in the evolution of Sunderland's C.A. Significantly, unlike the 1830-1850 period which carried the commercial core westwards along High Street West, the 1870-90 "burst" introduced commercial activity into Fawcett Street and other residential streets to the south. Analysis of the 1871 census returns show the nature of residential structure of Fawcett Street (Appendix 8). From the high quality residential status in 1871, it soon changed in the wake of commercial invasion. In anticipation of the new central railway station in 1879, properties were rapidly converted into offices and shops or rebuilt entirely. New functions were born. A central library was built at the south end of Fawcett Street in Mowbray Park in 1877. A new town hall was constructed on the site of the old shrubbery in 1890 into which local administration was concentrated. Later in the 1890's and at the turn of the century, the major banks moved in to capture the new trade. The high class houses of Fawcett Street built between 1826 and 1844 had only existed a mere 50 years before succumbing to commercial invasion.

The implication of these trends on the shape of the C.A. of Sunderland were two fold. Firstly, there was marked C.A. growth in a

southerly direction into, for example, Fawcett and John Street, which were to remain dominant commercially for another 75 years. Secondly, the 'tail' towards the east down High Street withered. In effect the shape of the C.A. of Sunderland in 1900 was closest to the quadrature cross considered by some <sup>(44)</sup> to be the ideal shape. The changing limits of the C.A. of Sunderland at 1800, 1850, 1900 are shown in Fig.10 along with further limits for 1950 and 1975. The problem of delimitation of the contemporary C.A. will be the purpose of Chapter 5. However, it is first necessary to understand the process by which land uses changed throughout the twentieth century in central Sunderland.

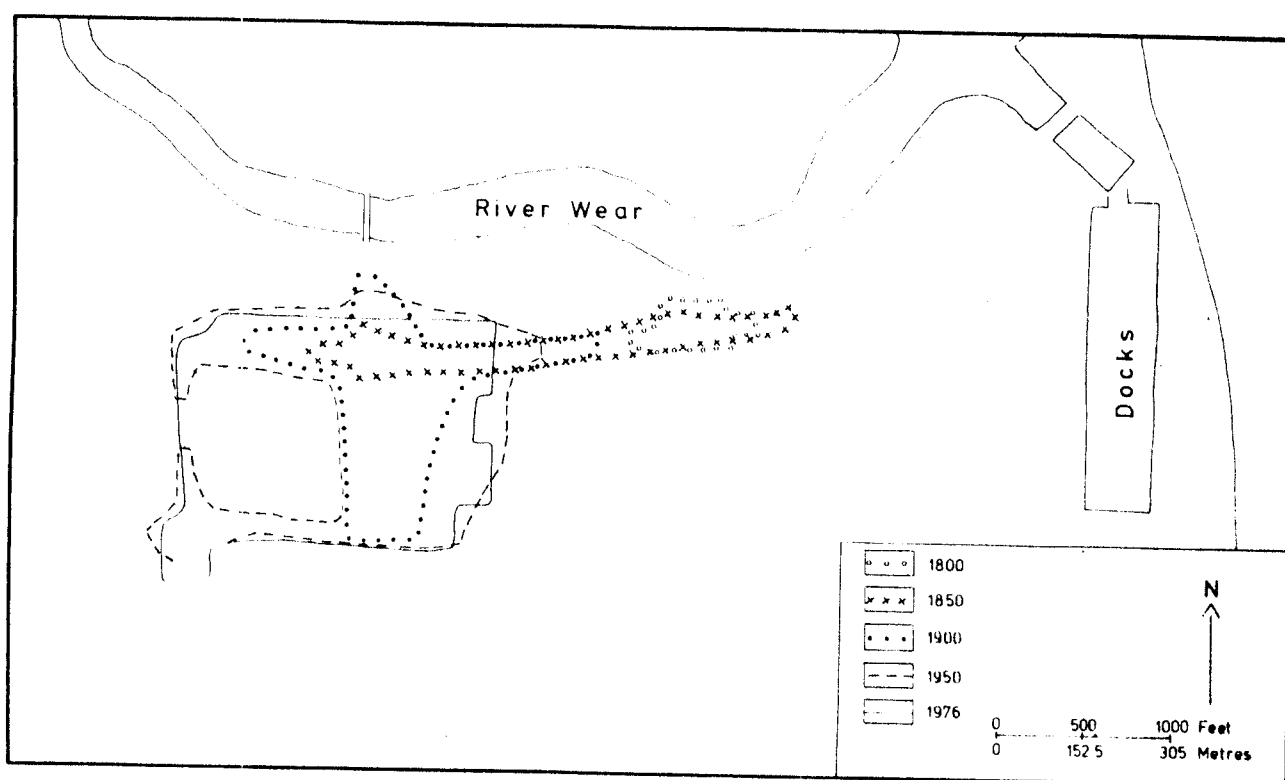

Fig. 10. Changing limits of the commercial core of Sunderland.

### Summary

A broad survey of source material in the nineteenth century reveals that the structure of the C.A. of Sunderland was strongly linked to the port and its economy at first. With the growing population and expanding built-up area, the internal composition and location of the C.A. changed. By 1900, it had migrated from its original focus and commercial activity invaded residential streets. Also, some functional segregation was in evidence; land use was becoming increasingly intense; and a modern C.A. had been established.

References and end notes

- (1) The most useful directories for the geographical analysis of central Sunderland are: Schofield's Universal Directory, Sunderland section (1793); Burnett's Directory for the parishes of Sunderland, Bishopwearmouth and Monkwearmouth (1831); Parson and White's, History, Directory and Gazetteer of the counties of Durham and Northumberland, Vols. I and II, (1828); Pigot and Co., Durham, (1828,1834); Williams' Commercial Directory of Newcastle, North and South Shields, Sunderland, etc., (1844); Vint and Carr's Directory of Sunderland (1844); White's General Directory of Newcastle upon Tyne, Sunderland etc., (1847); Ward's North of England Directory, (1850,1853,1857,1859-60 etc.); W. Wellan's & Co., History, Topography and Directory of Durham (1856,1865); Kelly's Post Office Directory of Durham, (1858,1873,1886 etc.); Christies Directory of (1873-4 etc.)
- (2) Weaknesses, pertinent to geographical studies, are highlighted by: Davies, W.K.D., Giggs, J.A. and Herbert, D.T., (1969), 'Directories, rate books and the commercial structure of towns'. Geography, Vol. 53, pp.41-54., and Holmes, R.S. (1974), 'Identifying nineteenth century properties', Area, Vol. 6, No. 4, pp. 273-277.
- (3) Early newspapers relating specifically to Sunderland are: Sunderland and Durham Gazette (1831- ); Sunderland Herald (1831- ); Sunderland Beacon (later, Sunderland Times (1838 - )).
- (4) An 1838 Rate Book exists which relates to Sunderland Parish only. Its purpose was to make "an assessment for the necessary relief of the poor ...." (P.1.) The earliest rate book for Bishopwearmouth parish is dated 1850. Both contain addresses, name of occupiers and owners, function of building and particulars of assessed amounts.
- (5) Population figures extracted from the 1801 census.
- (6) Bishopwearmouth to Sunderland was about 1,100 metres; Sunderland to Monkwearmouth measures 455 metres; Monkwearmouth to Bishopwearmouth was 1,100 metres.
- (7) Also considered critical in the location of the C.B.D. of Newcastle upon Tyne by: Conzen, M.R.G., (1960), 'The plan analysis of an English city centre' in K. Norborg (ed), Proceedings of the I.G.U. Symposium in Urban Geography, Lund University, pp.383-414.
- (8) Two relevant case studies exploring the relationships between port economies, industrialisation and commercial change are: Ward, D., (1966), 'The industrial revolution and the emergence of Boston's central business district', Economic Geography, Vol. 42, January, pp. 152-171; and Sharpless, J.B., (1976), 'The economic structure of port cities in the mid-nineteenth century: Boston and Liverpool, 1840-1860'. Journal of Historical Geography, Vol. 2, No. 2, pp.131-143.
- (9) For records on coal exports, see: Garbutt, G., (1819), 'A historical and descriptive view of the parishes of Monkwearmouth and Bishopwearmouth and the port and borough of Sunderland. (Sunderland); Nef, J.U., (1932), The rise of the British coal industry, (London); records of the River Wear Commissioners.

- (10) For details of launch and tonnage totals on the Wear see: Smith, J.W., and Holden, T.S., (1953), 'Where ships are born: Sunderland 1346-1946, a history of shipbuilding on the River Wear' (Sunderland.)
- (11) Lawton, R., (1972), 'An age of great cities', Town Planning Review, Vol. 43, No. 3, (July), pp. 201-205.
- (12) See for example, the case of Hull where average annual rates were even higher. Hull reached 100,000 population in 1850's (Sunderland's 100,000 figure was achieved in the 1870's). Wild, M.T. and Shaw, G.T. (1974) 'Locational behaviour of urban retailing during the nineteenth century: the example of Kingston upon Hull', Transactions, Institute of British Geographers, No. 61, March, pp. 101-117.
- (13) Kirwood, A.C. (1963), 'Residential building activity in North East England, 1853-1913', Manchester School of Economics and Social Studies, Vol. 31, (May), 1963, pp. 115-128.
- (14) The centres were calculated by finding the mean centre of the distribution of residential buildings at the three dates.
- (15) For notes on their precise location see: Randell, R.T., (1901), 'History of the parish boundaries in the Borough of Sunderland and neighbourhood', Antiquities of Sunderland, Vol. 2, pp. 1-16; and O.S. map 1st edition 1857.
- (16) See Smith, C.A., (1970), Sunderland Echo, October 22nd, p.11.
- (17) Garbutt, G., (1817), Plan of Sunderland, Bishopwearmouth and Monkwearmouth, (July 14th).
- (18) See, for example, Robson's, T. (1827), Plan of Sunderland, Bishopwearmouth and Monkwearmouth, (22nd November).
- (19) Descriptive morphological terms used by Conzen, M.R.G. (1960), 'The plan analysis of an English city centre' in K. Norborg, (Ed.) Proceedings of the I.G.U. Symposium in Urban Geography, Lund University, p.388.
- (20) As in the West Riding. See Ward, D., (1962), 'The pre-urban cadaster and the urban pattern of Leeds', Annals of the Association of American Geographers, Vol. 52, pp. 150-166.
- (21) John Street was only one third of a chain wide, while Fawcett Street, the prime residential street was one full chain when it was marked out. (See Robson's map).
- (22) Conzen, M.R.G., (1960), op.cit. p.388.
- (23) Rain's plan showed only 12 houses on the west-side of Silver Street compared to 22 houses on Robson's map of 1827.
- (24) Openshaw, S., (1974) in 'A theory of the morphological and functional development of the townscape in an historical context', Seminar Paper No. 4, Dept. of Geography, Newcastle upon Tyne, tries to develop a general operational theory. See also Idem, (1973), 'Process in urban morphology with special reference to South Shields', Ph.D., thesis, Newcastle University.

- (25) Garbutt, G., (1819), op.cit. p.151. Letter to the Editor, Sunderland and Durham General Shipping Gazette and Mercantile Advertiser, Feb. 26th 1831.
- (26) See Potts, T., (1892), Sunderland: a history of the town, port, trade, and commerce, p.55.
- (27) The complete numbering of all properties in Sunderland was commenced in 1831 but not finished until 1836.
- (28) Durham Chronicle and Sunderland Times, March 17th, 1832 reports on the locational effects of the railway and intended wet docks.
- (29) See, Sunderland Herald, November 12th and December 3rd, 1831, on health hazards.
- (30) A detailed distributional analysis is provided in a list of those on relief in 1818 in 'Local Pamphlets', Vol. 3. Of the 1138 persons listed, more than 97 per cent lived in streets in old Sunderland.
- (31) For example, badger baiting criticised in the Sunderland Herald, April 2nd, 1831, which described it as a regular "vulgar practice" watched by a large crowd on Saturday afternoons near the Barracks.
- (32) See, Bain, G.W., (1905), 'Early days in the banking in Sunderland', Antiquities of Sunderland, Vol. 6, pp.76-93. Rain's Eye Plan shows a building marked Sunderland Bank on Low Street. The first banks were private and organised by industrial firms, (see: Bain, G.W. 1905).
- (33) Sunderland and Durham Advertiser, April 16th, 1831 - The Backhouse and Company Bank. Also the Sunderland Joint Stock Bank is mentioned in on High Street, 1836, in Sykes, Local Pamphlets, Vol.3, (1833-1867).
- (34) See, Laxton, P. (1970), 'Liverpool in 1848' in Patmore, J.A., and Hodgkiss, A.G., (Eds), 'Merseyside in Maps'. pp. 20-21.
- (35) See, Alexander, D., (1970), 'Retailing in England during the Industrial Revolution'. (University of London, Athlone Press)pp.8-9.
- (36) Land values referred to in this section mean rateable values.
- (37) See, for example, Solomon, R.J. 'Property values as a structural element of urban evolution', Economic Geography, Vol. 45, January, No. 1. pp. 1-28.
- (38) The Rate Book records the names of occupiers and owners of property, the particulars of the assessment amount, whether or not payment had been made, and the function of the property.
- (39) 'isovals' are lines of equal land value.
- (40) Robson, B.T. (1969), 'Urban analysis: a study of city structure' (C.U.P.) pp. 108-115.
- (41) Hobart, Tasmania, in: Solomon, R.J., (1969), op.cit. pp. 1-28.

- (41) (Cont.) The geographical parallels between Sunderland and Hobart in terms of urban evolution are remarkable:
- (i) both towns grew up on one bank of a river estuary,
  - (ii) both had a Battery and Barracks dominating the dock and port area,
  - (iii) both had a main street leading away from the coast along which urban growth concentrated,
  - (iv) both experienced a migration of high value land away from its point of origin.
- (42) Personal communication: Dr. B.T. Robson, Department of Geography, Cambridge University.
- (43) "bursts" of commercial activity in C.B.D.'s through time have been identified by Bowden, M.J., (1971), 'Downtown through time: delimitation, expansion, and internal growth', Economic Geography, Vol. 47, No. 2, April, pp. 121-135.
- (44) Hartman, G.W., (1950), 'The Central Business District: a study in urban geography', Economic Geography, Vol. 26, pp. 237-244.

## Chapter 4

### LAND USE IN CENTRAL SUNDERLAND DURING THE 20TH CENTURY

#### Introduction

By the end of the nineteenth century, Sunderland possessed a modern C.A. Its spatial evolution has been traced by traditional documentary methods and suggested as the outcomes of a complex set of processes, including growth, development and decay. The purpose of the present chapter is to deal with C.A. development in Sunderland during the twentieth century and to develop an insight into the nature of more contemporary processes. More specifically, the C.A. is studied from the point of land use change.

Land use change may include two aspects: firstly it may involve physical alteration in the external and/or internal fabric of the property or parcel of land. Secondly, it may be reflected in functional conversion whereby a new activity use replaces an old one with or without physical modification. These twin facets of change are, of course, not mutually exclusive and, in reality, often occur simultaneously.

Functional change maybe further subdivided into two components: (a) the relocation of a firm, whereby a new activity is introduced into a property or parcel of land (see Chapter 6) and, (b) the conversion or adjustment of a property or parcel to other uses in response to changed circumstances.

Functional conversion or adjustment involves several mechanisms which are related to land use theory, ecology, urban economics, planning and perceptions. The causes of functional change would appear to be:- (1) the outbidding of some uses by others in competition for the same site, (2) the natural selection of activity uses for which that property or parcel of land is most suited. (3) the particular preferences of some uses for one part of the central area compared with another, (4) the built-in inertia induced by capital investment or traditional sites and clientele, (5) the artificial constraints of planning legislation and zoning regulations which encourage some uses in some areas and discourage other uses, (6) the nature and characteristics of ownership and tenancies of individual properties of varying ages, qualities and structures, (7) the changing relationships of technological factors, market considerations and attitudes.

The process of land use change involves, therefore, a multiplicity of spatial and non spatial factors. Traditional ecological considerations such as conversion, invasion, succession and competition provide well known models (Chapter 2) for studying land use change. Empirical land use data are presented and succession processes investigated using transition probability matrices. The significance of some of the results is tested using the chi-squared method and some interpretations made about the nature of land-use conversion in central Sunderland.

#### The data and procedures

Urban geographers and other scholars interested in land use conversion are confronted with several practical and theoretical difficulties. A prime prerequisite is the availability of land use data which span the necessary time period. Several sources were considered here mainly of rate books, and directory type but were rejected because they did not provide consistency. Not only had a variety of different directories to be used but there was also the difficulty of obtaining suitable maps for the specific dates required. Furthermore, not all directories contained the detailed locational information needed. They also failed to record land use of parcels of land such as open spaces, roads, unused patches, in the way they did for individual properties. (1)

It was, therefore, decided to base this analysis on land use data obtained from a set of maps devised for insurance purposes (2) which were available for 1894, 1927, 1948 and 1959. A field survey yielded data for 1975. The maps are mines of information and have not been developed to their full potential by urban researchers. (3) At a scale of 1 inch to 40 feet, they show, in detail, the utilisation of buildings, building heights, street reference numbers, structural and physical materials and, in some instances, the internal subdivisions of particular commercial properties.

A spatial grid was then drawn covering all the streets which were considered, either in an historical or a contemporary context, to be closely involved in the commercial emergence of a C.A. in Sunderland, (Fig. 11). The system of 100 metre squares was based on the national grid of the Ordnance Survey. The cells proved to be of manageable size, enabling direct spatial comparisons due to their size and shape regularity and lending themselves readily to aggregation to longer units. The use of co-ordinate mapping in geographical research is well

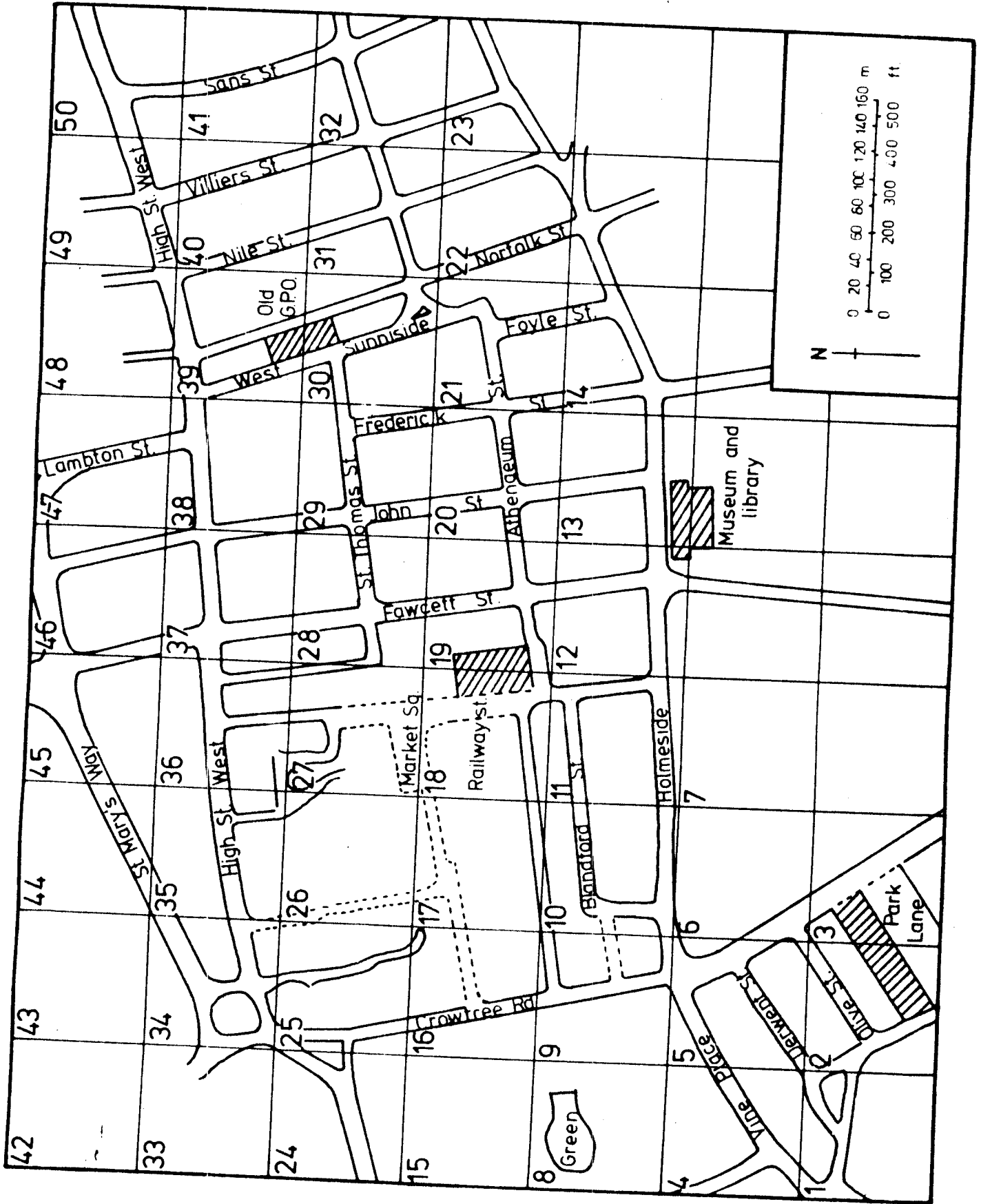

Fig. 11. Grid system and street locations.

established <sup>(4)</sup> with its advantages acknowledged <sup>(5)</sup> and found relevant in a British context. <sup>(6)</sup> The grid system outlined here and described further in Appendix 9, is the spatial framework for the following four chapters.

A regular array of points was imposed over the 50 cells with each cell containing 16 points. Land use data could thus be ideally collected for 800 locations in the C.A. However, no map coverage was available for cells 1,2,3,10,11,14,21,22,23,30,31,32,42 and parts of 5,17 and 18. In practice, therefore, the number of points for which data exists are: 502 in 1894, 559 in 1927, 558 in 1948, 556 for 1959, 558 points were used in 1975 based on a field survey with the same cells being excluded. (Fig. 12,A).

Activity uses were then observed and recorded at each point for the five dates specified. <sup>(7)</sup> Ten broad land use categories were devised: (i) residential, which includes not only houses, tenements, flats and other dwelling, but also other properties which were largely of a residential nature, such as boarding houses, hotels and hostels. (ii) offices, including financial, professional and general uses. (iii) industrial, incorporating workshops, factories, builders' yards, etc. (iv) institutions<sup>9</sup> such as libraries, churches, schools, and other similar services. (v) vacant property, (vi) communications which covers roads, railways and other major activity networks. (vii) open spaces and unused parcels of land, (viii) car parks which in 1894 appeared as stables, (ix) storage and warehousing. (x) retailing and all shop functions.

The usual problems of land use classification arose and were resolved as pragmatically as possible. Offices, for example, existing within an industrial concern were classed under 'industrial'. Whether a property was classified as one use or the other depended very much on individual cases, the criteria being the nature of the activity, its dominant characteristics and the particular site and physical attribute.

A summary of the land uses for 1894, 1927, 1948, 1959 and 1975, derived from the sample, is provided in Table 3 and graphed in Fig.12(B). In Table 3, columns are given for each year to record:

(a) absolute frequency of each activity (b) their relative frequency (c) the error in the sample figure <sup>(8)</sup>. Fig. 12(B) graphs the varying rates of change in four major central area uses from 1894-1975. The results in both tabular and graphical forms, confirm a number of features expected in terms of expected trends.

Table 3: Summary of sampled land use data for central Sunderland, 1894-1975

Land Uses	1894			1927			1948			1959			1975		
	Nos.	%	S.E.	Nos.	%	S.E.	Nos.	%	S.E.	Nos.	%	S.E.	Nos.	%	S.E.
Residential(1)	76	15.1	1.6	69	12.3	1.4	50	9.0	1.2	31	5.6	1.0	3	0.5	0.3
Vacant	10	2.0	0.6	12	2.1	0.6	16	2.9	0.7	14	2.5	0.7	10	1.8	0.6
Retailing	83	16.5	1.7	92	16.5	1.6	88	15.8	1.5	102	18.3	1.7	110	19.7	1.7
Industrial	42	8.4	1.3	60	10.7	1.3	80	14.3	1.5	87	15.7	1.5	42	7.6	1.1
Institutions	68	13.5	1.5	85	15.2	1.5	85	15.2	1.5	79	14.2	1.5	66	11.8	1.4
Communications	142	28.3	2.0	157	28.1	1.9	161	28.8	1.9	158	28.4	1.9	194	34.8	2.0
Offices	16	3.2	0.8	18	3.2	0.7	17	3.0	0.7	17	3.1	0.7	18	3.2	1.3
Storage/Warehousing	25	5.0	1.0	31	5.6	1.0	26	4.7	0.9	34	6.1	1.0	28	5.0	0.9
Open Spaces	26	5.2	1.0	25	4.5	0.9	25	4.5	0.9	26	4.7	0.9	69	12.4	1.4
Car Park	14	2.8	0.8	10	1.8	0.6	10	1.8	0.2	8	1.4	0.6	18	3.2	0.7
Total	502	100.0	-	559	100.0	-	558	100.0	-	556	100.0	8	558	100.0	-

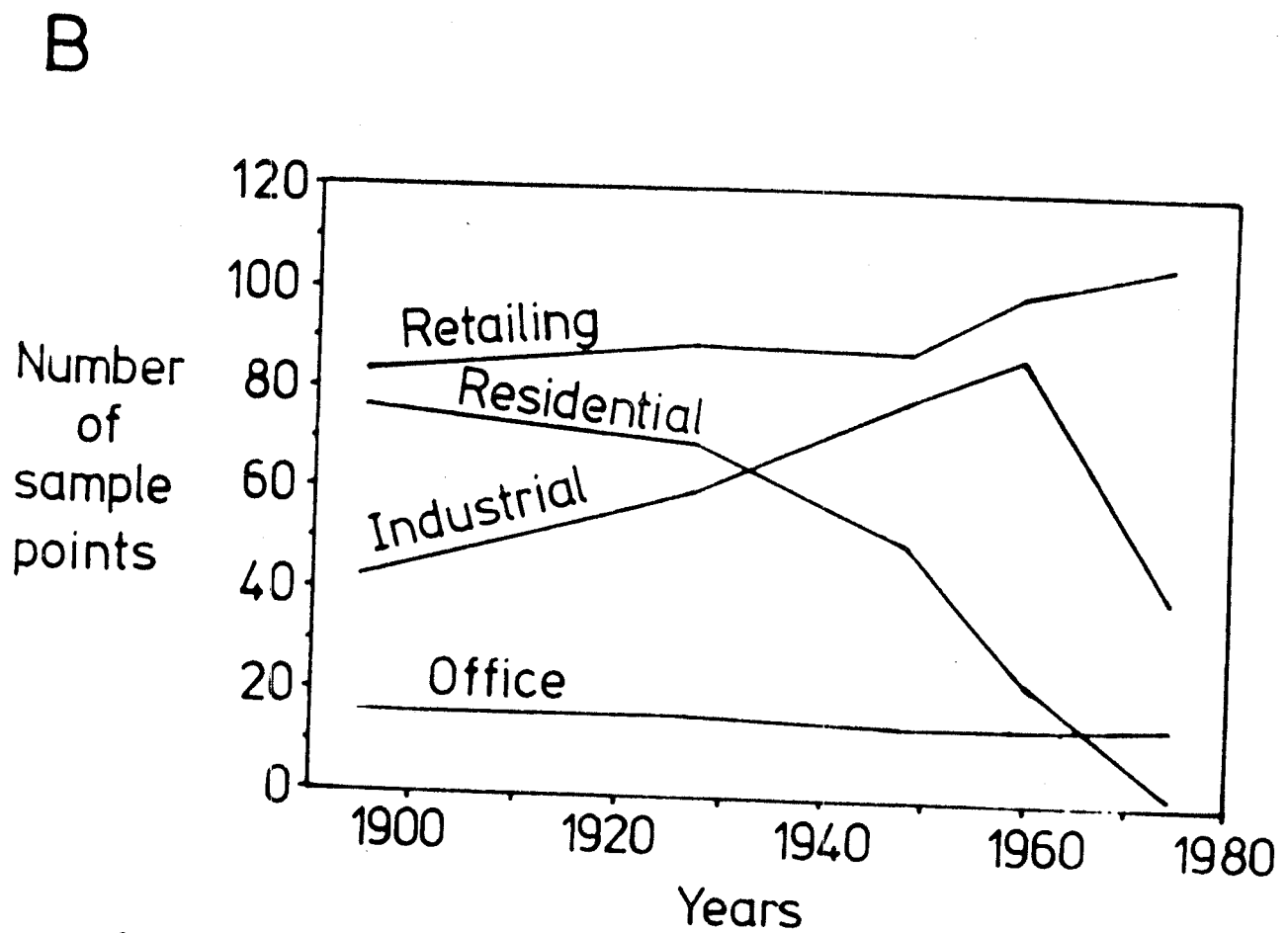
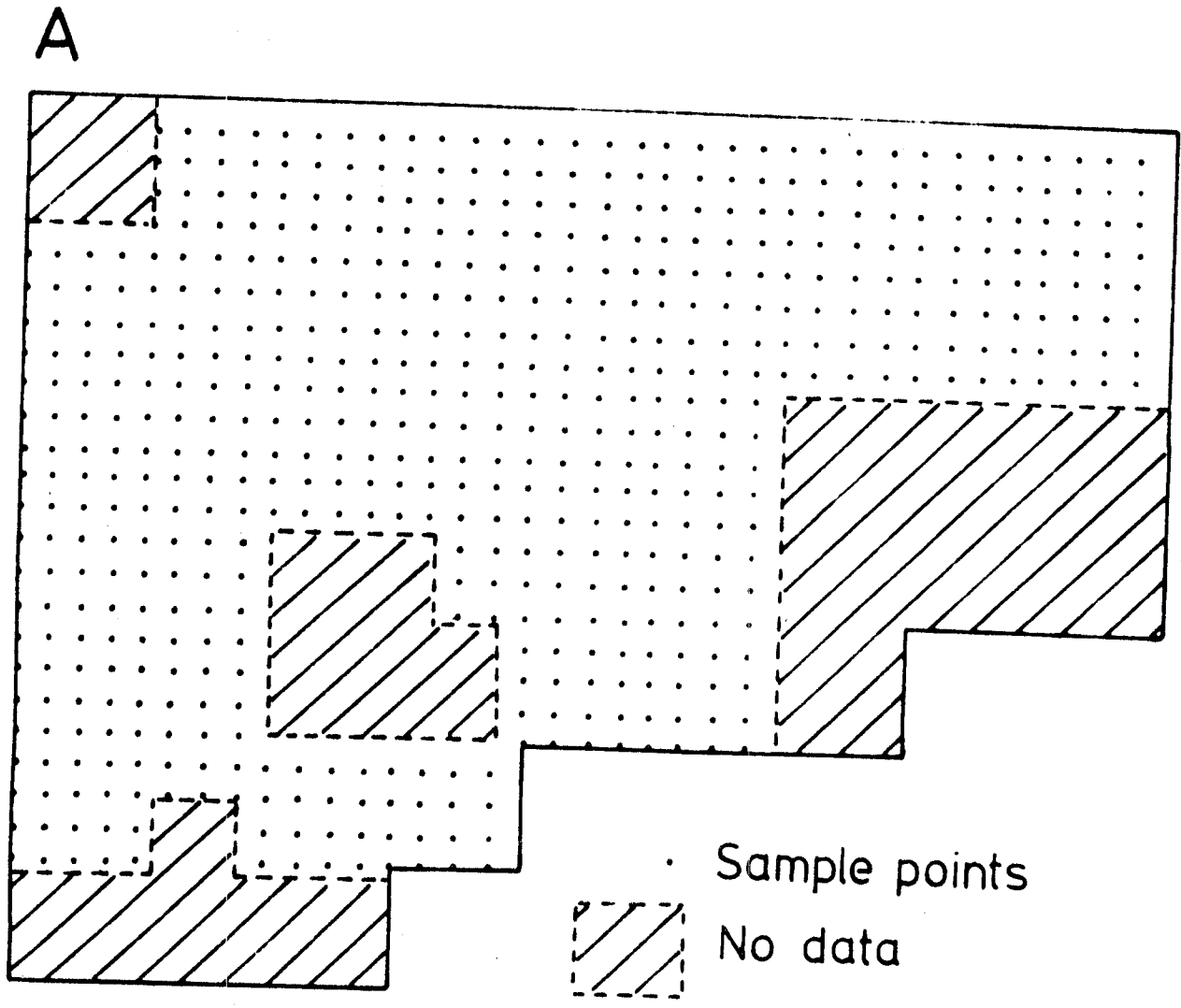

Fig. 12. Land use data for central Sunderland.

Communications occupied a continuously dominant position with about 28 per cent of all points under this use, reflecting the importance of movement in central areas. The increase in this category of land use in the recent period (1959-1975) upto 34.8 per cent is attributed to the construction of St. Mary's Way, an inner ring road scheme, and new one way schemes at the north end of Bridge and Bedford Streets. The expansion of roads was achieved mainly at the expense of residential, warehousing and industrial uses.

A second notable feature of the land use changes recorded above is the decline of the importance of the residential function. In 1894 it totalled 15 per cent of central Sunderland's ground floor space; by 1974 it had virtually ceased to exist. The decline had been in evidence since the turn of the century, but became more marked in the inter war and, particularly, in the post war periods. At least five interrelated factors explain the extinction of ground floor use in central Sunderland: (a) the demolition of ageing and poor quality housing in older, inner areas such as Crowtree Road, (b) the need for more car-parking space in areas close to main shopping and business streets, such as Boughton Street, (c) the redevelopment of the central area for more shopping and service space such as South and Northumberland Streets, (d) the relative inability of residential properties to withstand the rise in rents and rates of central area sites is compared to other more intensive uses, eg. Blandford, Olive and Derwent Streets, (e) the declining residential importance of streets in inner Sunderland,<sup>(9)</sup> with the planned extension of new suburban estates in the fifties and sixties.

The marked decline in industrial and related uses in recent years is also attributable to planned change. The road schemes of St. Mary's Way and West Wear Street and the C.A. redevelopment both resulted in the expulsion of industrial users to other sites. The mixed and miscellaneous uses found in these areas consisting of, for example bottling plants, factories, garages and builders yards, were based in small and short-lived businesses.

Retailing tended to expand continuously in the 1894-1975 period. Expansion is conspicuous particularly in the contemporary period due again to planned developments. Some losses to retailing use, however, were recorded in less central streets. Bridge Street, High Street West, east of John Street and Crowtree Road fit into this category. Invasion of former residential streets by retailers was most common in Blandford, Olive and Derwent Streets.

Lastly, the table and graph exhibit the stability of the office function. The concentration of offices in John Street, Foyle Street and adjoining areas, still apparent in 1975, had been established by 1894.

Probability transition, matrices: method

The nature of land use change in central Sunderland is now investigated by posing a number of specific questions: (i) How stable/unstable are the commercial land uses in the C.A.? (ii) Are some commercial land uses more or less likely to change than others? (iii) Can any sequences of land use changes be identified? (iv) How much is commercial land use independent of the initial state?

The method used to develop these and other themes is derived from work completed by Bourne <sup>(10)</sup> and Lee. <sup>(11)</sup> Both used probability transition matrices in their analysis of land use changes. Both explored the conceptual and operational problems of describing commercial land use change. Both worked in central urban areas albeit in the North American context. Their contributions are therefore from several stand-points relevant for this piece of work.

Bourne looks on land use change as a "complex probabilistic process of adjustment" (p.12) He illustrates the process through empirical data from Toronto to using non-public real property statistics only, for the period 1952 to 1962. Despite the complex nature of property conversions he discovered a considerable degree of order and stability" in the change process. To illustrate the structure of these land use changes he used probability matrices. These were obtained by tabling the initial land use against the code at the end of the period and repeating the tabulation for two approximately equal subdivisions of the period (1952-56; 1957-62). The similarity of the matrices were tested by correlation analysis.

Lee also developed a conceptual review of commercial land use succession and presents some data for downtown Denver from 1947 to 1971. He shows how further characteristics of land use succession can be revealed by developing first and second order probability transition matrices. He also cautions against the danger of using these matrices to predict future land use states on the basis of a previous time period.

Bourne's and Lee's work have much in common in terms of conceptual basis, operational approach and empirical conclusions. The present writer investigated the same field and problem to see if their approaches and conclusions are applicable to Sunderland.

It is possible to examine land use change in a C.A. by representing the process as a succession of mutually exclusive states. A matrix can be constructed which enumerates the occurrences that a given land use is succeeded by another land use. Such a matrix is called a transition frequency matrix. The tendency for one land use to succeed another can be emphasised by converting the frequency matrix to decimal fractions. If every element, land use ij, of the transition frequency matrix is divided by the grand total of all entries in the matrix, the entries are expressed as their relative frequency of occurrences. This matrix is clearly dependent upon the overall frequency with which land uses appear in the sequence.

However, a matrix expressing the tendency of one land use to follow another regardless of the total abundance of the initial state, is called a transition proportion matrix. This is constructed by dividing each element in the ith row by the total of the ith row. The rows will sum to one.

$$\begin{array}{cccc}
 & LU_1 & LU_2 & LU_3 \dots\dots\dots LU_n \\
 LU_1 & P_{11} & P_{12} & P_{13} \dots\dots\dots P_{1n} \\
 LU_2 & P_{21} & P_{22} & P_{23} \dots\dots\dots P_{2n} \\
 LU_3 & P_{31} & P_{32} & P_{33} \dots\dots\dots P_{3n} \\
 \\ 
 P = & & & \\
 \\ 
 LU_n & P_{n1} & P_{n2} & P_{n3} \dots\dots\dots P_{nn}
 \end{array}$$

where

$$\sum_{i=1}^n P_{ij} = 1.00$$

and  $P_{ij} \geq 0$  for all i and j.

If the succession of one given land use can be observed sufficiently long the exact probability could be determined. Probability can be defined as relative frequency of occurrences. The transition proportion matrix can be seen as an estimate of the probabilities that certain land uses follow other land uses. Regarded in this light the matrix can be referred to as a transition probability matrix.

Many of these successions have the properties of Markov chains sequences in which the state of point is dependent in a probabilistic manner on the immediately preceding state. The theory of Markov chains is introduced and developed in statistical and mathematical contexts elsewhere.<sup>(12)</sup> A particularly useful and concise treatise on the geographical applications is provided by Collins.<sup>(13)</sup>

From a brief survey of some of the geographical literature it is clear that the Markov chain behaviour is often assumed. At some point, the probabilities of occurrences of a land use is independent of the initial state in the sequence. This is termed, the 'memory' in a Markov process which 'remembers' a preceding event. The number of steps through which a memory persists is an index to the order in the series.

In this study, transition probability matrices are used in the descriptive sense. No predictions of land use change in central Sunderland are attempted. Simple recording on each sample point is made against the terminal use at the end of each period.

### Probability transition matrices : results

The results of the land use analysis for the C.A. are summarised for each time period in three matrices. The A matrix contains the actual occurrences of the ten land use categories. The 'B' matrix expresses these as proportions or as probabilities of change of each type  $i$  to  $j$  over the given time period. The 'C' matrix sum the probabilities to unity (one) over all elements in the matrices, thus providing row and column totals which are relative or weighted rates of conversion into and out of each land use types.

Data for 1894 to 1975 are presented first; followed by more detailed temporal subdivisions. (i) 1894-1975 (Table 4).

If land use change is aggregated for the whole period from 1894 to 1975, some important regulations come to light. Firstly, the diagonal column in the matrices confirms the general stability of land uses. Of the 498 points sampled, 257 (52 per cent) staying under the same land use over the time period. Secondly, there are marked individual differences in the behaviour of different land uses. For example; in the category termed 'communication', 95 per cent of points which recorded that land use in 1894 were still under the same use in 1975. The comparable figures for 'retailing', 'offices' and 'institutions' were 67.5 per cent, 56.3 per cent and 50.7 per cent respectively. At the other end of the scale other categories of land use were very unlikely to remain constant throughout the period. The respective 'stability' percentages for 'car park', 'residential' and 'storage' were 7 per cent, 4 per cent and 8 per cent.

The frequency of conversions between various land uses can also be assessed by reference to the matrices included in Table 4. Low or nil probabilities occur between uses which have rare, or few, functional linkages in a business sense. 'Offices' and 'industry' provide two such land uses. Furthermore, the lack of 'relationship' is 'two-way': offices have never been converted into industrial space, and industry has never been converted into offices. There are some uses, however, which have a 'one-way' relationship with another use. Study of the matrices B and C will show, for example, that residential uses have been converted into every other of the nine uses listed. And yet none of those nine uses themselves have been converted into residential use over the same time span. The comparison of 'gain' and 'loss' figures is an instructive way of gaining further insights into the dynamics of

Table:4 (A) Land Use Conversion Data, Central Sunderland, 1894 - 1975

Initial Land Use, 1894	Terminal Land Use 1975										TOTAL	
	1	2	3	4	5	6	7	8	9	10		
Residential	1.	3	3	12	6	6	13	2	7	17	6	75
Vacant	2.	0	2	2	1	3	1	0	0	1	0	10
Retailing	3.	0	3	56	1	1	7	1	6	7	1	83
Industrial	4.	0	0	8	11	0	7	0	8	6	2	42
Institutions	5.	0	0	14	2	35	4	2	1	11	0	69
Communications	6.	0	2	3	0	0	132	0	1	0	0	138
Offices	7.	0	0	2	0	1	1	9	0	2	1	16
Storage/Warehousing	8.	0	0	2	9	0	7	2	2	0	3	25
Open Spaces	9.	0	0	4	2	6	6	2	0	6	0	26
Car Park	10.	0	0	3	1	1	2	0	1	5	1	14
Total		3	10	106	33	53	180	18	26	55	14	498

Table:4 (B) Absolute Probabilities, 1894 - 1975

	1	2	3	4	5	6	7	8	9	10	TOTAL
1.	.0400	.0400	.1600	.0800	.0800	.1733	.0267	.0933	.2267	.0800	1.000
2.	.0000	.2000	.2000	.1000	.3000	.1000	.0000	.0000	.1000	.0000	1.000
3.	.0000	.0361	.6747	.0120	.0120	.0843	.0120	.0723	.0843	.0120	1.000
4.	.0000	.0000	.1905	.2619	.0000	.1667	.0000	.1905	.1429	.0476	1.000
5.	.0000	.0000	.2029	.0290	.5073	.0580	.0290	.0145	.1594	.0000	1.000
6.	.0000	.0145	.0217	.0000	.0000	.9565	.0000	.0072	.0000	.0000	1.000
7.	.0000	.0000	.1250	.0000	.0625	.0625	.5625	.0000	.1250	.0625	1.000
8.	.0000	.0000	.0800	.3600	.0000	.2800	.0800	.0800	.0000	.1200	1.000
9.	.0000	.0000	.1539	.0769	.2308	.2308	.0769	.0000	.2308	.0000	1.000
10.	.0000	.0000	.2143	.0714	.0714	.1429	.0000	.0714	.3571	.0714	1.000
Total	.0400	.2906	2.0230	.9912	1.2640	2.2550	.7821	.5292	1.4262	.3935	10.000

Table:4 (C) Relative Probabilities, 1894 - 1975

	1	2	3	4	5	6	7	8	9	10	TOTAL
1.	.0060	.0060	.0241	.0121	.0121	.0261	.0040	.0141	.0341	.0121	.1507
2.	.0000	.0040	.0040	.0020	.0060	.0020	.0000	.0000	.0020	.0000	.0200
3.	.0000	.0060	.1125	.0020	.0020	.0141	.0020	.0121	.0141	.0020	.1668
4.	.0000	.0000	.0161	.0220	.0000	.0141	.0000	.0161	.0121	.0040	.0844
5.	.0000	.0000	.0281	.0040	.0703	.0080	.0040	.0020	.0220	.0000	.1384
6.	.0000	.0040	.0060	.0000	.0000	.2651	.0000	.0020	.0000	.0000	.2771
7.	.0000	.0000	.0040	.0000	.0020	.0020	.0181	.0000	.0040	.0020	.0321
8.	.0000	.0000	.0040	.0181	.0000	.0141	.0040	.0040	.0000	.0060	.0502
9.	.0000	.0000	.0080	.0040	.0121	.0121	.0040	.0000	.0121	.0000	.0523
10.	.0000	.0000	.0060	.0020	.0020	.0040	.0000	.0020	.0100	.0020	.0280
Total	.0060	.0200	.2128	.0662	.1065	.3616	.0361	.0523	.1104	.0281	1.0000

central area land use change. The gains and losses of each land use category can be derived from the 'A' matrix. Comparison of the sum of the rows and columns for each element gives the absolute change in a particular land use. A higher row total than column total indicates that land use type has 'lost' to other uses. A higher column total than row total, on the other hand, indicates that that land use has gained in frequency. For example, Land use 1 (Residential) went out of existence on 15 occasions and came into existence only 3 times; 'residential' therefore recorded a decline of 72. On the other hand, Land use 3 (Retailing) gained on 23 (106-83) occasions over the same period.

The broad pattern for 1894-1975 naturally obscures important shorter term variations and tendencies. By examining five periods as determined by data availability there are some significant findings.

(11) 1894-1927 (Table 5)

It is apparent, when this time period is examined in a similar fashion to the 1894-1975 period, that a very high proportion of all land uses remain in the same category of use. In these thirty-three years, the proportion reached as high as 82 per cent. Within the main diagonal column which reflects the stability aspect of land uses, there are again important variations. The probability of 'communications', for example, remaining in that use was 100 per cent, for 'car-parks' 43 per cent, and 'open spaces' 58 per cent; but only 20 per cent for 'vacant land'. The weighted results in 'C' give a more realistic measure of stability with residential service, communications and retailing standing out as the dominant uses with very high stability in the 1894-1927 period; and 'industry', 'storage/warehousing', 'open space' and 'offices' ranked in order of stability. Comparison of pair-wise relationships of the land uses throws further light on the selectivity of the conversion processes.

(111) 1927-1948 (Table 6)

Stability of land remained high with 83 per cent of all uses not changing in the 21 years of the time period. As in the earlier period, the most stable uses were communications, institutions/services and shops, whilst the most likely to change were storage, vacant land and car parks.

Table:5 (A) Land Use Succession, Central Sunderland 1894-1927

Initial Land Use, 1894	Terminal Land Use, 1927										TOTAL	
	1	2	3	4	5	6	7	8	9	10		
Residential	1	53	2	6	5	5	0	0	4	0	1	76
Vacant	2	2	2	2	1	1	0	0	0	0	0	10
Retailing	3	3	1	73	0	3	0	1	2	0	0	83
Industrial	4	0	3	2	31	2	0	0	4	0	0	42
Institutions	5	2	1	1	0	62	0	1	1	0	0	68
Communications	6	0	0	0	0	0	142	0	0	0	0	142
Offices	7	0	1	2	0	0	0	13	0	0	0	16
Storage/Warehousing	8	0	0	0	7	0	0	1	16	0	1	25
Open Spaces	9	0	0	2	1	6	1	2	0	14	0	26
Car Park	10	0	0	0	6	0	0	0	2	0	6	14
Total	T	60	10	88	52	79	144	18	29	14	8	502

Table: (B) (absolute probability)  
Terminal Use, 1894 - 1927

	1	2	3	4	5	6	7	8	9	10	TOTAL
1	0.6974	0.0263	0.0789	0.0658	0.0658	0.0000	0.0000	0.0526	0.0000	0.0132	1.0000
2	0.2000	0.2000	0.2000	0.2000	0.1000	0.1000	0.0000	0.0000	0.0000	0.0000	1.0000
3	0.0361	0.0120	0.8795	0.0000	0.0361	0.0000	0.0120	0.0241	0.0000	0.0000	1.0000
4	0.0000	0.0714	0.0476	0.7381	0.0476	0.0000	0.0000	0.0952	0.0000	0.0000	1.0000
5	0.0294	0.0147	0.0147	0.0000	0.9118	0.0000	0.0147	0.0147	0.0000	0.0000	1.0000
6	0.0000	0.0000	0.0000	0.0000	0.0000	1.0000	0.0000	0.0000	0.0000	0.0000	1.0000
7	0.0000	0.0625	0.1250	0.0000	0.0000	0.0000	0.8125	0.0000	0.0000	0.0000	1.0000
8	0.0000	0.0000	0.0000	0.2800	0.0000	0.0000	0.0400	0.6400	0.0000	0.0400	1.0000
9	0.0000	0.0000	0.0769	0.0385	0.2308	0.0385	0.0769	0.0000	0.5385	0.0000	1.0000
10	0.0000	0.0000	0.0000	0.4286	0.0000	0.0000	0.0000	0.1429	0.0000	0.4286	1.0000
T	0.9629	0.3870	1.4227	1.7509	1.3921	1.1385	0.9562	0.9695	0.5385	0.4817	10.0000

Table:5 (C) Relative (Weighted) Probabilities

	1	2	3	4	5	6	7	8	9	10	TOTAL
1	0.1056	0.0040	0.0120	0.0100	0.0100	0.0000	0.0000	0.0080	0.0000	0.0020	0.1514
2	0.0040	0.0040	0.0040	0.0040	0.0020	0.0020	0.0000	0.0000	0.0000	0.0000	0.0199
3	0.0060	0.0020	0.1454	0.0000	0.0060	0.0000	0.0020	0.0040	0.0000	0.0000	0.1653
4	0.0000	0.0060	0.0040	0.0618	0.0040	0.0000	0.0000	0.0080	0.0000	0.0000	0.0837
5	0.0040	0.0020	0.0020	0.0000	0.1235	0.0000	0.0020	0.0020	0.0000	0.0000	0.1355
6	0.0000	0.0000	0.0000	0.0000	0.0000	0.2829	0.0000	0.0000	0.0000	0.0000	0.2829
7	0.0000	0.0020	0.0040	0.0000	0.0000	0.0000	0.0259	0.0000	0.0000	0.0000	0.0319
8	0.0000	0.0000	0.0000	0.0139	0.0000	0.0000	0.0020	0.0319	0.0000	0.0020	0.0498
9	0.0000	0.0000	0.0040	0.0020	0.0120	0.0020	0.0040	0.0000	0.0279	0.0000	0.0518
10	0.0000	0.0000	0.0000	0.0120	0.0000	0.0000	0.0000	0.0040	0.0000	0.0120	0.0279
T	0.1195	0.0199	0.1753	0.1036	0.1574	0.2869	0.0359	0.0578	0.0279	0.0159	1.0000

Table:6 (A)

## Lane Use Succession, Central Sunderland, 1927-1948

Initial Land Use,  
1927

Terminal Land Use 1948

		1	2	3	4	5	6	7	8	9	10	TOTAL
Residential	1	49	2	6	6	2	0	0	0	2	1	68
Vacant	2	0	3	1	3	2	1	0	1	0	1	12
Retailing	3	1	6	76	3	0	1	2	0	1	2	92
Industrial	4	0	1	0	49	0	0	0	5	3	2	60
Institutions	5	0	2	2	1	79	0	0	1	0	0	85
Communications	6	0	0	0	0	0	157	0	0	0	0	157
Offices	7	0	0	0	0	0	1	15	0	0	2	18
Storage/Warehousing	8	0	2	2	9	0	0	0	18	0	0	31
Open Spaces	9	0	0	1	3	2	1	0	1	16	1	25
Car Park	10	0	0	0	6	0	0	0	0	3	1	10
Total	T	50	16	88	80	85	161	17	26	25	10	558

Table:6 (B) Absolute Probability, 1927 - 1948

	1	2	3	4	5	6	7	8	9	10	TOTAL
1	0.7206	0.0294	0.0882	0.0882	0.0294	0.0000	0.0000	0.0000	0.0294	0.0147	1.0000
2	0.0000	0.2500	0.0833	0.2500	0.1667	0.0833	0.0000	0.0833	0.0000	0.0833	1.0000
3	0.0109	0.0652	0.8261	0.0326	0.0000	0.0109	0.0217	0.0000	0.0109	0.0217	1.0000
4	0.0000	0.0167	0.0000	0.8167	0.0000	0.0000	0.0000	0.0833	0.0500	0.0333	1.0000
5	0.0000	0.0235	0.0235	0.0118	0.9294	0.0000	0.0000	0.0118	0.0000	0.0000	1.0000
6	0.0000	0.0000	0.0000	0.0000	0.0000	1.0000	0.0000	0.0000	0.0000	0.0000	1.0000
7	0.0000	0.0000	0.0000	0.0000	0.0000	0.0556	0.8333	0.0000	0.0000	0.1111	1.0000
8	0.0000	0.0645	0.0645	0.2903	0.0000	0.0000	0.0000	0.5806	0.0000	0.0000	1.0000
9	0.0000	0.0000	0.0400	0.1200	0.0800	0.0400	0.0000	0.0400	0.6400	0.0400	1.0000
10	0.0000	0.0000	0.0000	0.6000	0.0000	0.0000	0.0000	0.0000	0.3000	0.1000	1.0000
T	0.7315	0.4493	1.1257	2.2096	1.2055	1.1898	0.8551	0.7991	1.0303	0.4042	10.0000

Table:6 (C) Relative Probability, 1927 - 1948

	1	2	3	4	5	6	7	8	9	10	TOTAL
1	0.0878	0.0036	0.0108	0.0108	0.0036	0.0000	0.0000	0.0000	0.0036	0.0018	0.1219
2	0.0000	0.0054	0.0018	0.0054	0.0036	0.0018	0.0000	0.0018	0.0000	0.0018	0.0215
3	0.0018	0.0108	0.1362	0.0054	0.0000	0.0018	0.0036	0.0000	0.0018	0.0036	0.1649
4	0.0000	0.0018	0.0000	0.0878	0.0000	0.0000	0.0000	0.0090	0.0054	0.0036	0.1075
5	0.0000	0.0036	0.0036	0.0018	0.1416	0.0000	0.0000	0.0018	0.0000	0.0000	0.1523
6	0.0000	0.0000	0.0000	0.0000	0.0000	0.2814	0.0000	0.0000	0.0000	0.0000	0.2814
7	0.0000	0.0000	0.0000	0.0000	0.0000	0.0018	0.0269	0.0000	0.0000	0.0036	0.0323
8	0.0000	0.0036	0.0036	0.0161	0.0000	0.0000	0.0000	0.0323	0.0000	0.0000	0.0556
9	0.0000	0.0000	0.0018	0.0054	0.0036	0.0018	0.0000	0.0018	0.0287	0.0018	0.0448
10	0.0000	0.0000	0.0000	0.0108	0.0000	0.0000	0.0000	0.0000	0.0054	0.0018	0.0179
T	0.0896	0.0287	0.1577	0.1434	0.1523	0.2885	0.0305	0.0466	0.0448	0.0179	1.0000

By analysing change 'into' and change 'out of' some of the features observed for 1894 and 1927 are present for this period. Residential uses lost out to all other uses except offices and storage, gaining only on one occasion over shopping. Workshops and industry gained as did roads and railway. Vacant land, on the other hand, became more frequent replacing most other uses excepting residential, offices and open space. Other notable reversals of trends occurred in shopping and storage uses which lost ground to most other uses. Little or no change in terms of gains and losses were recorded in car parking, unused/open space, offices and services.

High probabilities are given for industry and warehousing in a 'two-way' relationship indicating the continued close functional linkages between these two activities. Conversion into residential use remained virtually non-existent but there is some evidence of conversion out of residential into other use being more selective than in the 1894-1927 period. Essentially, those uses with little affinity for each other in 1927-48 were the same as for the earlier periods, i.e. car parks and institutional services, communication and residential and offices and industrial.

Matrix 'C' transforms the data into weightings. Comparison of C matrices demonstrates that one cannot assume that probabilities empirically estimated from different time periods are constant. For 1927-48 the stability of the residential use has declined markedly whilst the retailing, services and communication categories have retained their essential stability. The close association of warehousing and industry is apparent. There is clearer evidence also that properties tend to convert into more intensive use although some properties may themselves be converted into less intensive parcel use. The distinction between 'parcel of land' and 'property' is worth bearing in mind.

(iv) 1948-1959 (Table 7)

Stability of land uses reached its highest figure in this time period with 85 per cent of all properties remaining in the same use in 1959 as in 1948 (although it should be noted that the span of years is only 11). Basically, the same uses i.e. shopping, institutions, services and communications were most stable being those in which more capital investment was involved.

Table: 7 (A)

## Land Use Succession, Central Sunderland, 1927-1948

Initial Land Use,  
1948

Terminal Land Use, 1948

		1	2	3	4	5	6	7	8	9	10	TOTAL
Residential	1	31	4	4	3	0	0	1	2	3	0	48
Vacant	2	0	2	3	4	0	1	0	5	1	0	16
Retailing	3	0	0	88	0	0	0	0	0	0	0	88
Industrial	4	0	4	2	63	1	1	0	7	2	0	80
Institutions	5	0	2	0	4	77	0	0	1	1	0	85
Communications	6	0	0	3	0	1	156	0	1	0	0	161
Offices	7	0	1	0	0	0	0	15	0	1	0	17
Storage/Warehousing	8	0	1	0	7	0	0	1	16	1	0	26
Open Spaces	9	0	0	1	5	0	0	0	1	17	1	25
Car Park	10	0	0	1	1	0	0	0	1	0	7	10
Total	T	31	14	102	87	79	158	17	34	26	8	556

Table: 7 (B) Absolute Probability, 1948 - 1959

	1	2	3	4	5	6	7	8	9	10	TOTAL
1	0.6458	0.0833	0.0833	0.0625	0.0000	0.0000	0.0208	0.0417	0.0625	0.0000	1.0000
2	0.0000	0.1250	0.1875	0.2500	0.0000	0.0625	0.0000	0.3125	0.0625	0.0000	1.0000
3	0.0000	0.0000	1.0000	0.0000	0.0000	0.0000	0.0000	0.0000	0.0000	0.0000	1.0000
4	0.0000	0.0500	0.0250	0.7875	0.0125	0.0125	0.0000	0.0875	0.0250	0.0000	1.0000
5	0.0000	0.0235	0.0000	0.0471	0.9059	0.0000	0.0000	0.0118	0.0118	0.0000	1.0000
6	0.0000	0.0000	0.0186	0.0000	0.0062	0.9689	0.0000	0.0062	0.0000	0.0000	1.0000
7	0.0000	0.0588	0.0000	0.0000	0.0000	0.0000	0.8824	0.0000	0.0588	0.0000	1.0000
8	0.0000	0.0385	0.0000	0.2692	0.0000	0.0000	0.0385	0.6154	0.0385	0.0000	1.0000
9	0.0000	0.0000	0.0400	0.2000	0.0000	0.0000	0.0000	0.0400	0.6800	0.0400	1.0000
10	0.0000	0.0000	0.1000	0.1000	0.0000	0.0000	0.0000	0.1000	0.0000	0.7000	1.0000
T	0.6458	0.3791	1.4545	1.7163	0.9246	1.0439	0.9416	1.2150	0.9390	0.7400	10.0000

Table: 7 (C) Relative Probability, 1948 - 1959

	1	2	3	4	5	6	7	8	9	10	TOTAL
1	0.0558	0.0072	0.0072	0.0054	0.0000	0.0000	0.0018	0.0036	0.0054	0.0000	0.0863
2	0.0000	0.0036	0.0054	0.0072	0.0000	0.0018	0.0000	0.0090	0.0018	0.0000	0.0288
3	0.0000	0.0000	0.1583	0.0000	0.0000	0.0000	0.0000	0.0000	0.0000	0.0000	0.1583
4	0.0000	0.0072	0.0036	0.1133	0.0018	0.0018	0.0000	0.0126	0.0036	0.0000	0.1439
5	0.0000	0.0036	0.0000	0.0072	0.1385	0.0000	0.0000	0.0018	0.0018	0.0000	0.1529
6	0.0000	0.0000	0.0054	0.0000	0.0018	0.2806	0.0000	0.0018	0.0000	0.0000	0.2896
7	0.0000	0.0018	0.0000	0.0000	0.0000	0.0000	0.0270	0.0000	0.0018	0.0000	0.0306
8	0.0000	0.0018	0.0000	0.0126	0.0000	0.0000	0.0018	0.0288	0.0018	0.0000	0.0468
9	0.0000	0.0000	0.0018	0.0090	0.0000	0.0000	0.0000	0.0018	0.0306	0.0018	0.0450
10	0.0000	0.0000	0.0018	0.0018	0.0000	0.0000	0.0000	0.0018	0.0000	0.0126	0.0180
T	0.0558	0.0252	0.1835	0.1565	0.1421	0.2842	0.0306	0.0612	0.0468	0.0144	1.0000

The lack of conversion linkages between the various categories is obvious from the tables. Residential uses had no affinity in the conversion process, with, for example, services and communications; and offices had none with shopping, industry, services, communications, open spaces and car parking.

Major gains occurred in shopping and industry, open space and storage. Losses, on the other hand, occurred in services and, of course, residential.

(v) 1959-1975 (Table 8)

The redevelopment of a part of central Sunderland and its consequential impact on the commercial fortunes of other neighbouring properties has meant that the 1959-1975 period has the lowest figure for functional stability. Only two-thirds of the properties and parcels contained the same uses in 1975 as they had in 1958. Residential uses, vacant plots, storage and industrial functions were the most affected. Roads and railways continued to achieve the highest stability, closely followed by offices. The residential function virtually ceased to be a central area land use in Sunderland in this period at ground floor level.

The degree of functional affinities between various land uses are highlighted again in the 'B' matrix with broadly similar trends as in earlier periods. Some uses such as car parking and offices never appear as having any connections. In the same category are residential and offices and industry and offices. The matrix for 1959-1975 is rendered rather different from the other matrices on account of the massive planned conversion of land uses compared with the slower more sporadic and natural conversions of the earlier periods.

From the relative weightings in matrix 'C' and their comparison with other weighted figures, it is evident that the conversion of land use in central Sunderland has been a continual process: the rate of conversion has quickened in the post-war period but the trends were apparent even in 1894-1927.

(vi) 1894-1975 (Table 9)

The overall picture of land use conversion in central Sunderland between 1894 and 1975 is shown in Table 9. In these matrices, all the previous occurrences have been recorded cumulatively and the probabilities calculated on that basis.

Table: 8 (A)

Land Use Succession, Central Sunderland, 1959-1975

<u>Initial Land Use</u> <u>1959</u>		<u>Terminal Land Use, 1975</u>										
		1	2	3	4	5	6	7	8	9	10	TOTAL
Residential	1	3	0	3	0	3	4	0	4	12	2	31
Vacant	2	0	1	3	0	0	2	0	3	4	1	14
Retailing	3	0	1	74	0	0	11	2	1	13	0	102
Industrial	4	0	0	8	40	4	11	0	5	17	2	87
Institutions	5	0	0	8	0	57	5	1	0	6	2	79
Communications	6	0	2	2	1	0	148	0	1	0	1	155
Offices	7	0	0	0	0	1	1	15	0	0	0	17
Storage/Warehousing	8	0	4	4	1	0	6	0	11	4	4	34
Open Spaces	9	0	0	5	0	1	4	0	3	12	1	26
Car Park	10	0	0	1	0	0	2	0	0	0	5	8
Total		3	8	108	42	66	194	18	28	68	18	553

Table: 8 (B) Absolute Probability, 1959 - 1975

	1	2	3	4	5	6	7	8	9	10	TOTAL
1	0.0968	0.0000	0.0968	0.0000	0.0968	0.1290	0.0000	0.1290	0.3871	0.0645	1.0000
2	0.0000	0.0714	0.2143	0.0000	0.0000	0.1429	0.0000	0.2143	0.2857	0.0714	1.0000
3	0.0000	0.0098	0.7255	0.0000	0.0000	0.1078	0.0196	0.0098	0.1275	0.0000	1.0000
4	0.0000	0.0000	0.0920	0.4598	0.0460	0.1264	0.0000	0.0575	0.1954	0.0230	1.0000
5	0.0000	0.0000	0.1013	0.0000	0.7215	0.0633	0.0127	0.0000	0.0759	0.0253	1.0000
6	0.0000	0.0129	0.0129	0.0065	0.0000	0.9548	0.0000	0.0065	0.0000	0.0065	1.0000
7	0.0000	0.0000	0.0000	0.0000	0.0588	0.0588	0.8824	0.0000	0.0000	0.0000	1.0000
8	0.0000	0.1176	0.1176	0.0294	0.0000	0.1765	0.0000	0.3235	0.1176	0.1176	1.0000
9	0.0000	0.0000	0.1923	0.0000	0.0385	0.1538	0.0000	0.1154	0.4615	0.0385	1.0000
10	0.0000	0.0000	0.1250	0.0000	0.0000	0.2500	0.0000	0.0000	0.0000	0.6250	1.0000
T	0.0968	0.2118	1.6776	0.4956	0.9616	2.1634	0.9146	0.8560	1.6508	0.9718	10.0000

Table: 8 (C) Relative Probability, 1959 - 1975

	1	2	3	4	5	6	7	8	9	10	TOTAL
1	0.0054	0.0000	0.0054	0.0000	0.0054	0.0072	0.0000	0.0072	0.0217	0.0036	0.0561
2	0.0000	0.0018	0.0054	0.0000	0.0000	0.0036	0.0000	0.0054	0.0072	0.0018	0.0253
3	0.0000	0.0018	0.1338	0.0000	0.0000	0.0199	0.0036	0.0018	0.0235	0.0000	0.1844
4	0.0000	0.0000	0.0145	0.0723	0.0072	0.0199	0.0000	0.0090	0.0307	0.0036	0.1573
5	0.0000	0.0000	0.0145	0.0000	0.1031	0.0090	0.0018	0.0000	0.0108	0.0036	0.1429
6	0.0000	0.0036	0.0036	0.0018	0.0000	0.2676	0.0000	0.0018	0.0000	0.0018	0.2803
7	0.0000	0.0000	0.0000	0.0000	0.0018	0.0018	0.0271	0.0000	0.0000	0.0000	0.0307
8	0.0000	0.0072	0.0072	0.0018	0.0000	0.0108	0.0000	0.0199	0.0072	0.0072	0.0615
9	0.0000	0.0000	0.0090	0.0000	0.0018	0.0072	0.0000	0.0054	0.0217	0.0018	0.0470
10	0.0000	0.0000	0.0018	0.0000	0.0000	0.0036	0.0000	0.0000	0.0000	0.0090	0.0145
T	0.0054	0.0145	0.1953	0.0759	0.1193	0.3508	0.0325	0.0506	0.1230	0.0325	1.0000

Table: 9(A) Total Changes, Central Sunderland, 1894-1927-1948-1959-1975

Initial Land Use,		Terminal Land Use										
		1	2	3	4	5	6	7	8	9	10	TOTAL
Residential	1	136	8	19	14	10	4	1	10	17	4	223
Vacant	2	2	8	9	9	3	5	0	9	5	2	52
Retailing	3	4	8	311	3	3	12	5	3	14	2	365
Industrial	4	0	8	12	183	7	12	0	21	22	4	269
Institutions	5	2	5	11	5	275	5	2	3	7	2	317
Communications	6	0	2	5	1	1	603	0	2	0	1	615
Office	7	0	2	2	0	1	2	58	0	1	2	68
Storage/Warehousing	8	0	7	6	24	0	6	2	61	5	5	116
Open Spaces	9	0	0	9	9	9	6	2	5	59	3	102
Car Park	10	0	0	2	13	0	2	0	3	3	19	42
Total	T	144	48	386	261	309	657	70	117	133	44	2169

Table: 9(B) Absolute Probability, 1894-1927-1948-1959-1975

	1	2	3	4	5	6	7	8	9	10	TOTAL
1	0.6099	0.0359	0.0852	0.0628	0.0448	0.0179	0.0045	0.0448	0.0762	0.0179	1.0000
2	0.0385	0.1538	0.1731	0.1731	0.0577	0.0962	0.0000	0.1731	0.0962	0.0385	1.0000
3	0.0110	0.0219	0.8521	0.0082	0.0082	0.0329	0.0137	0.0082	0.0384	0.0055	1.0000
4	0.0000	0.0297	0.0446	0.6803	0.0260	0.0446	0.0000	0.0781	0.0818	0.0149	1.0000
5	0.0063	0.0158	0.0347	0.0158	0.8675	0.0158	0.0063	0.0095	0.0221	0.0063	1.0000
6	0.0000	0.0033	0.0081	0.0016	0.0016	0.9805	0.0000	0.0033	0.0000	0.0016	1.0000
7	0.0000	0.0294	0.0294	0.0000	0.0147	0.0294	0.8529	0.0000	0.0147	0.0294	1.0000
8	0.0000	0.0603	0.0517	0.2069	0.0000	0.0517	0.0172	0.5259	0.0431	0.0431	1.0000
9	0.0000	0.0000	0.0882	0.0882	0.0882	0.0588	0.0196	0.0490	0.5784	0.0294	1.0000
10	0.0000	0.0000	0.0476	0.3095	0.0000	0.0476	0.0000	0.0714	0.0714	0.4524	1.0000
T	0.6656	0.3502	1.4148	1.5464	1.1089	1.3754	0.9143	0.0632	1.0223	0.6390	10.0000

Table: 9(C) Relative Probability, 1894-1927-1948-1959-1975

	1	2	3	4	5	6	7	8	9	10	TOTAL
1	0.0627	0.0037	0.0088	0.0065	0.0046	0.0018	0.0005	0.0046	0.0078	0.0018	0.1028
2	0.0009	0.0037	0.0041	0.0041	0.0014	0.0023	0.0000	0.0041	0.0023	0.0009	0.0240
3	0.0018	0.0037	0.1434	0.0014	0.0014	0.0055	0.0023	0.0014	0.0065	0.0009	0.1683
4	0.0000	0.0037	0.0055	0.0844	0.0032	0.0055	0.0000	0.0097	0.0101	0.0018	0.1240
5	0.0009	0.0023	0.0051	0.0023	0.1268	0.0023	0.0009	0.0014	0.0032	0.0009	0.1462
6	0.0000	0.0009	0.0023	0.0005	0.0005	0.2780	0.0000	0.0009	0.0000	0.0005	0.2835
7	0.0000	0.0009	0.0009	0.0000	0.0005	0.0009	0.0267	0.0000	0.0005	0.0009	0.0314
8	0.0000	0.0032	0.0028	0.0111	0.0000	0.0028	0.0009	0.0281	0.0023	0.0023	0.0535
9	0.0000	0.0000	0.0041	0.0041	0.0041	0.0020	0.0009	0.0023	0.0272	0.0014	0.0470
10	0.0000	0.0000	0.0009	0.0060	0.0000	0.0009	0.0000	0.0014	0.0014	0.0088	0.0194
T	0.0664	0.0221	0.1780	0.1203	0.1425	0.3029	0.0323	0.0539	0.0613	0.0203	1.0000

The stability of most of the major commercial land uses is worthy of note and confirm the conclusions of Bourne in central Toronto. Land uses in decreasing order of stability are: communications, institutional services, offices, retailing, industry, residential, open space, storage/warehousing, car park and vacant premises.

An interesting observation from Matrix 'B' and 'C' is that of all uses, the office - industry pair is the only one to consistently, over the 81 years, record no conversion probability between one another. Other pairs of uses with negligible probability, over the same period, are residential and offices, warehousing and institutional services, and car park and institutional services.

It is instructive to summarise here the 'gains' and losses recorded to each use in the different time spans studied. From it one can readily perceive the major changes in the commercial land uses of the C.A. The only use to have continually declined in importance is the residential category. Some uses, such as industry and institutional services increased then progressively declined. Other uses, such as open space, and car parking declined at first but later increased. Still others have remained initially unchanged with gains balancing the losses over the whole of the 1894-1975 period; warehousing and offices. Finally, retailing has continually gained. The various fortunes of the ten selected 'uses' are shown in Table 10.

#### Tests of significance of land use conversion

It has been established from the data presented above that land use changes in central Sunderland followed regular patterns. These were identified both for the various time periods and for the different land use categories. It is now necessary to know how significant these results are.

The standard chi square ( $X^2$ ) test is one of the oldest and most commonly used method for matching actual data against data as expected. (15)  
A prerequisite step before the test can be applied is to state the problem as a null hypothesis. The null hypothesis assumes that there is no relationships between the values being tested. If the result shows that the value is significantly greater at a required significance level then the null hypothesis is rejected, and an alternative is accepted.

The null hypothesis in this study can be stated thus: land use change in the C.A. has been independent of the initial state of the land

Table 10. Land use gains and losses in central Sunderland

Use		1894-1927			1927-48			1948-59			1959-75			1894-1975		
		G	L	B	G	L	B	G	L	B	G	L	B	G	L	B
Residential	(1)	7	23	-16	1	19	-18	0	17	-17	0	28	-28	8	87	-79
Vacant	(2)	8	8	0	13	9	+4	12	14	-2	7	13	-6	40	44	-4
Retailing	(3)	15	10	+5	12	16	-4	14	0	+14	34	28	+6	75	54	+21
Industry	(4)	21	11	+10	31	11	+20	24	17	+7	2	47	-45	78	86	-8
Institutions	(5)	17	6	+11	6	6	0	2	8	-6	9	22	-13	34	42	-8
Communications	(6)	2	0	+2	4	0	+4	2	5	-3	46	7	+39	54	12	+42
Offices	(7)	5	3	+2	2	3	-1	2	2	0	3	2	+1	12	10	+2
Warehousing	(8)	13	9	+4	8	13	-5	18	10	+8	17	23	-6	56	55	+1
Open Space	(9)	0	12	-12	9	9	0	9	8	+1	56	14	+42	74	43	+31
Car Park	(10)	2	8	-6	9	9	0	1	3	-2	13	3	+10	25	23	+2
Total		90	90	0	95	95	0	84	94	0	187	187	0	456	456	0

G = Gains

L = Loss

B = Balance

use between 1894 and 1975. Or expressed in the converse way: a terminal land use bears no relationship at all to the state of the land use at the beginning of the period studied.

The values of  $X^2$  were then computed using the standard formula:

$$X^2 = \sum \frac{(O-E)^2}{E} \quad \text{where } O \text{ means}$$

the observed and E means the expected values. The value of  $X^2$  for 1894-1927, 1927-48, 1948-1959 and 1959-75 are presented as an aggregate in Table 11. More detailed results for each separate period are given in Appendices 10, 11, 12 and 13. In all cases, the sub sections (c) contain the observed, expected and  $X^2$  results respectively. The results of the test of the hypothesis that the transition probabilities are independent of time show that in central Sunderland from 1894 to 1975 the system of commercial land use displayed a time dependent (if somewhat irregular) transition process.

By referring to a table of degrees of freedom it can be seen that the  $X^2$  value for this set of data yields a probability value of less than 0.1%. This means that the null hypothesis on which the analysis was based would produce differences as great as this 'by chance' less than one time in one thousand. In other words, there is more than a 99.9% probability that the evidence of the null hypothesis is correct.

The chief factor in the rejection of the null hypothesis, as can be seen from Table 11, is the strong tendency for major land uses to remain under the same use. With the exception of 'vacant' land, the pattern of succession of all other C.A. uses had been stable.<sup>(16)</sup> Commercial land use change in, for example, residential, retailing, institutions, communications, offices and industrial uses displayed a strong time dependent transition process. The remaining uses showed relatively weaker but still significant tendencies of stability from one time period to another.

More detailed temporal analysis of the transition probabilities is contained in Appendices 10-13 inclusive. For the periods 1894-1927, 1927-1948, and 1948-1959, a relative constancy in the transition process is observable with the  $X^2$  values for individual uses being broadly comparable. In the 1959-75 period, however, there is a relatively significant reduction in the correlation between observed and expected values for open space, car parking, storage/warehousing, vacant and residential uses.

Table:11(A) Observed land use change, 1894-1975

Initial Land Use	1894										TOTAL
	1	2	3	4	5	6	7	8	9	10	
Residential	136	8	19	14	10	4	1	10	17	4	223
Vacant	2	8	9	9	3	5	0	9	5	2	52
Retailing	4	8	311	3	3	12	5	3	14	2	365
Industrial	0	8	12	183	7	12	0	21	22	4	269
Institutions	2	5	11	5	275	5	2	3	7	2	317
Communications	0	2	5	1	1	603	0	2	0	1	615
Offices	0	2	2	0	1	2	58	0	1	2	68
Storage/Warehousing	0	7	6	24	0	6	2	61	5	5	116
Open Spaces	0	0	9	9	9	6	2	3	59	3	102
Car Park	0	0	2	13	0	2	0	3	3	19	42
Total	144	48	386	261	309	657	70	117	133	44	2169

Table: 11(B) Expected, 1894 - 1975

	1894										TOTAL
	1	2	3	4	5	6	7	8	9	10	
1	14.8050	4.9350	39.6856	26.8340	31.7690	67.5477	7.1969	12.0290	13.6740	4.5237	223.0000
2	3.4523	1.1508	9.2540	6.2573	7.4080	15.7510	1.6782	2.8050	3.1886	1.0549	52.0000
3	24.2324	8.0775	64.9562	43.9212	51.9986	110.5602	11.7796	19.6888	22.3813	7.4043	365.0000
4	17.8589	5.9530	47.8718	32.3693	38.3223	81.4813	8.6814	14.5104	16.4947	5.4569	269.0000
5	21.0456	7.0152	56.4140	38.1452	45.1604	96.0207	10.2305	17.0996	19.4380	6.4306	317.0000
6	40.8299	13.6100	109.4467	74.0041	87.6141	186.2863	19.8479	33.1743	37.7109	12.4759	615.0000
7	4.5145	1.5048	12.1014	8.1826	9.6874	20.5973	2.1946	3.6680	4.1697	1.3794	68.0000
8	7.7012	2.5671	20.6436	13.9585	16.5256	35.1369	3.7437	6.2573	7.1130	2.3532	116.0000
9	6.7718	2.2573	18.1521	12.2739	14.5311	30.8963	3.2918	5.5021	6.2545	2.0692	102.0000
10	2.7884	0.9295	7.4744	5.0539	5.9834	12.7220	1.3555	2.2656	2.5754	0.8520	42.0000
Total	144.0000	48.0000	386.0000	261.0000	309.0000	657.0000	70.0000	117.0000	133.0000	44.0000	2169.0000

Table:11 (C)

	1894										TOTAL
	1	2	3	4	5	6	7	8	9	10	
1	992.1144	1,9036	10,7821	6,1382	14,9167	59,7846	5,3358	0,3423	0,8090	0,0606	1092,1873
2	0,6109	40,7661	0,0070	1,2022	2,6229	7,3382	1,6782	13,6822	1,0291	0,8468	69,7837
3	16,8926	0,0007	931,9749	38,1261	46,1717	87,8626	3,9019	14,1459	3,1386	3,9446	1146,1597
4	17,8589	0,7039	26,8799	700,9609	25,6009	59,2486	8,6814	2,9024	1,8375	0,3890	845,0633
5	17,2357	0,5789	36,5589	28,8006	1169,7454	86,2811	6,6215	11,6259	7,9588	3,0526	1368,4595
6	40,8299	9,9039	99,6752	72,0177	85,6255	932,1689	19,8479	29,2948	37,7109	10,5560	1337,6306
7	4,5145	0,1629	8,4320	8,1826	7,7906	16,7917	1419,0761	3,6680	2,4095	0,2792	1471,3071
8	7,7012	7,6549	10,3875	7,2237	16,5256	24,1615	0,8121	478,9264	0,6277	2,9772	556,9977
9	6,7718	2,2573	4,6144	0,8733	2,1054	20,0615	0,5070	0,0458	444,8142	0,4188	482,4693
10	2,7884	0,9295	4,0096	12,4932	5,9834	9,0364	1,3555	0,2381	0,0700	386,5582	423,4621
Total	1107,3184	64,8617	1133,3213	876,0183	1377,0882	1302,7351	1467,8174	554,8719	500,4052	409,0828	8793,5204

## Summary

Land use changes in central Sunderland, during the twentieth century have been investigated from the view point of ecological and probabilistic considerations. Theoretical assumptions of succession are supported by some of the main findings.

By 1900, the C.A. of Sunderland had assumed modern characteristics (see Chapter 3). In the ensuing years, a high level of stability in land use was identified by the frequency of land uses to remain in the same use over long time periods. Where the scale or rate of succession changed, as between 1959-1975, the occurrence can be attributed to large scale planned C.A. redevelopments.

An increasingly intensive use of land (residential to commercial) was evident, although 'vacant' land as an example of a less intensive use was an important counter-tendency.

Certain land uses were mutually exclusive and in terms of succession were rarely associated. Conversely other uses had a high affinity for each other and were frequently related in the succession process.

The built-in stability of land use and the linkages between some pairs of uses was confirmed by an elementary statistical test. The main features of change in the C.A. during the present century agreed with similar findings by other geographers.

## References and end notes

- (1) For a fuller discussion of the problem of commercial analysis on the basis of directories, see: Davies, W.K.D., Giggs, J.A., and Herbert, D.T. (1969). 'Directories, rate books and the commercial structure of towns' Geography 53, pp. 41-54.
- (2) The maps were produced by Chas. E. Goad Ltd., 56 Crouch Hill, London.
- (3) The Goad maps are similar in nature to the Sanborn Insurance Maps used by S.H. Ross in his study of the C.B.D. of Mexico City in 1906. See Ross, S.H. (1971); 'The C.B.D. of Mexico City as indicated on the Sanborn Maps of 1906', Professional Geographer, Vol. 23. pp. 31-39. The value of the Goad maps is recently noted by:- Rowley, G. and McL. Shepherd. P. (1976). 'A source of elementary spatial data for town centre research in Britain; Area Vol. 8, No. 3, pp. 201-208.
- (4) Pred, A.R. (1973): 'Urbanisation, domestic planning problems and Swedish geographic research.' Progress in Geography: Ed. C. Board et al, Vol. 5, pp. 9-11.
- (5) For example: Robson, B.T. (1969) 'Urban Analysis: a study of city structure', C.UP; pp.45, Kazlowski, J.l., Hughes, J.T. and Brown, R., (1972). 'Threshold Analysis: a quantitative planning method', p.229

Other geometrical grids were considered, eg. hexagonal grids possess the unique property that flows from one cell to another occurs directly across faces rather than through nodes, or through two faces as for square.

- (6) Robertson, I.M. (1970), 'The National Grid and Social Geography', Geography, Vol. 55, Pt 4, (November), pp. 426-432.
- (7) Note: (a) only ground floor data is fully recorded,  
(b) the time intervals between the control years are not constant: 36 years, 21 years, 11 years, and 16 years, respectively.
- (8) The "Standard Error" is calculated for each percentage using the formula
- $$SE = \sqrt{\frac{p\% \times q\%}{n}}$$
- where n is the number of sample points, p% is the percentage of the interested variable, and q% if 100 - p% (i.e. all the rest). See Gregory, S. (1968), 'Statistical Methods and the Geographer' Second edition, Chapter 7, pp. 100-124.
- (9) The vital exclusion of ground floor residential use in central Sunderland by 1975 has been compensated by increases at higher levels with the construction of Astral, Plant and Solar Houses part of the C.A. development.
- (10) Bourne, L.S. (1971), 'Physical adjustment processes and land use succession : a conceptual review and central city example', Economic Geography, Vol. 47, January, No. 1, pp. 1-13.
- (11) Lee, Y. (1974), 'A conceptual discussion and an empirical analysis of commercial land use succession, Environment and Planning, A. Vol. 6. pp. 655-674.
- (12) Parzon, E. (1962), Stochastic Processes. Hoel P.G. et.al. (1972): Introduction to Stockastic Processes.
- (13) Collins L. (1975) 'An Introduction to Markov Chain Analysis' Cat.mag. No. 1 pp. 36.
- (14) Lee Y. (1974) Op.cit. p.660.
- (15) Dalton R. et. al. (1972) 'Correlation techniques in Geography' (Philip). Chapter 2 pp. 6-22, gives a good introduction to the Chi Square test. For a more advanced treatment, see: Rogers, A. (1974), 'Statistical analysis of spatial dispersion': the quadrat method, (Pion), Chapter 5, pp. 54-70.
- (16) Bourne, L.S., (1971) op.cit., in his study of central Toronto reached similar conclusions, p.9 et seq.

Chapter 5

THE DELIMITATION AND INTERNAL STRUCTURE OF A C.A. OF SUNDERLAND

Introduction

Numerous methods can be used to define the limits and structure of a central business district, <sup>(1)</sup> the best known of which was pioneered by Murphy and Vance. The main difficulty of identifying and studying the C.A. of British towns by this method is the absence of floor space data. <sup>(2)</sup> Nevertheless, a large number of British towns and cities C.B.D.s have been successfully delimited using this (or a modified) method. <sup>(3)</sup> The availability of essential land use data allows the Murphy Vance method to be applied. This chapter seeks, therefore, to:- (a) tests its application to Sunderland (b) evaluate and interpret results, and (c) develop the method as a framework for examining the internal commercial structure of the C.A.

The Murphy-Vance method of delimitation requires a "distinction between central business use and land uses that are not central business in character." <sup>(4)</sup> Central Business Use consists of all branches of retailing, office activity and services. Non Central Business Use was considered by Murphy and Vance to include residential use, public property, organisational establishments, industry, wholesaling and storage, vacant properties and railway tracks and yards.

Having made this distinction, the land use on each floor level of each lot in every city block within the central part can be recorded and mapped. From these data, two critical ratios are calculated: (i) Central Business Height Index (C.B.H.I) is formed by dividing the total floor area of central business use in a block at all levels by the total ground floor (C.B.H.I. =  $\frac{\text{Central Business Space}}{\text{Total Ground Floor Area}}$ ). (ii) Central Business Intensity Index (C.B.I.I. is found by dividing the total central business space at all levels by the total floor space at all levels multiplied by 100. (C.B.I.I. =  $\frac{\text{Central Business Space}}{\text{Total Floor Space}} \times 100$ )

To be considered part of a C.B.D., Murphy and Vance suggest that a block should have a C.B.H.I. of at least 1.0 and a C.B.I.I. of at least 50 per cent. Furthermore, each qualifying block should be one of a contiguous group of blocks surrounding the Peak Land Value Intersection Point (P.L.V.I.). However, any block which does not reach these values, but is surrounded by blocks that do, is considered part of a C.B.D.

The present delimitation exercise suffers from the same difficulties, both practical and theoretical, as other attempts to regionalise and devise precise boundaries when, in reality, (urban) phenomena form a continuum in space. However, so long as the regionalisation idea does not 'divert attention from other priorities of study' <sup>(5)</sup> there are sound reasons for using the method.

It will be shown later that the Murphy-Vance method produces a realistic delimitation of the C.A. of Sunderland. More important, it provides the framework for a more detailed study of the internal structure of the commercial core.

#### Data and application of method

The Murphy-Vance method of delimitation is dependent on available, accurate land use data. The writer was fortunate to gain access to suitable data for the study area which had been collected by the Local Planning Department. The data were available for an extensive area which had been sub-divided into ten arbitrary zones. Within each zone every block of property space was allocated a number, as was every plot within each block (Appendix 14). The results of both internal and external surveys were stored on cards, one card holding the data for one floor level of one plot.

The abstraction of the relevant data was time consuming and somewhat laborious. The grid system adopted (see Chapter 4), did not conform with plot, block and zone boundaries. Where the geometrical lines of the grid cut across the plot units, an allocation of floor space data was made on the basis of proportional space in each cell.

The floor space totals for each cell were recorded in terms of (a) floor levels and (b) major land use categories as set out in Table 12.

Table 12: Method of collection of floor space data

Cell No.	Floors'					Total
	B.	G.	4	2	3	
<u>Central Business Uses</u>						
- Shops						
- Offices (financial)						
- (other)						
- Services						
<u>Non Central Business Uses</u>						
- Residential						
- Institutions eg. churches						
- Vacant						
- Industry						
- Storage/Warehousing						

B = Basement; G = Ground Floor; 1,2,3,4, refer to storeys. 4th floor includes all floors above that level.

Whilst great care was taken in the correct and accurate abstraction and processing of data, three weaknesses in the quality of the data must be noted. Firstly, the large numbers of field operators involved in the initial survey produced, despite careful guidelines,<sup>(6)</sup> occasional inconsistencies from individual to individual. Secondly, the accuracy of land use recordings of upper floor space did not appear as high as for ground floors and, again occasional inconsistencies of classification were discovered. Thirdly, in a few instances some plots had been left out of the survey by mistake. In all three cases, changes were made to eradicate the weaknesses and to ensure the data were as reliable as possible.

Careful consideration was also afforded to the relevance of Murphy and Vance's technical distinction of land use in the context of Sunderland. Their general distinction of 'central' and 'non-central' business use was accepted with two important changes.

Firstly, wholesaling was classed in the present work as a 'central'-business use in the light of contemporary trends in retailing.<sup>(7)</sup> Secondly, multi-storey car parks and public transport terminals were included under 'central' business use.<sup>(8)</sup> In Sunderland, multi-storey parks are integral elements of the built environment of the modern C.A. Functionally, they are shown (Chapters 6 and 7) to be highly significant determinants of commercial activity. Transport terminals<sup>(9)</sup> were classed as 'central' use for similar reasons. Like car parks, they are planned components of the modern C.A. and are critical factors in determining vehicular and pedestrian movements. Again, it seemed unrealistic to exclude them from the 'central' category. Both modifications should be borne in mind when the following results are presented for central Sunderland.

Results: The calculations of the two critical ratios for each of the 50 cells are summarised in Table 13.

Table 13: The two ratios of the Murphy-Vance method

Cell No.	CBH1	CB11	Cell No.	CBH1	CB11
1	0.8	41.6	26*	1.3(1.9)	38.0(72.4)
2	1.4	53.5	27	2.6	89.1
3	0.7	46.7	28	3.3	94.1
4	0.4	10.2	29	3.4	87.4
5	1.7	69.5	30*	2.4(1.9)	60.4(46.6)
6	1.5	60.2	31	0.1	8.2
7	0.7	36.1	32	0.0	1.7
8	0.6	25.5	33	0.0	0.0
9	0.9	36.6	34	0.7	34.9
10	1.8	76.2	35	2.6	89.0
11	1.9	91.9	36	3.3	95.1
12	4.8	96.9	37	2.2	69.8
13	3.5	91.9	38	1.4	51.2
14	1.0	38.5	39*	1.2(1.0)	54.2(49.8)
15	0.4	19.8	40	0.3	14.5
16	2.2	74.1	41	0.0	0.0
17	2.6	91.9	42	0.0	0.0
18*	1.1(1.6)	56.7(75.1)	43	0.0	0.0
19*	3.4(2.0)	78.3(67.6)	44	0.0	0.0
20	1.5	55.7	45	0.0	0.0
21	1.9	52.8	46	0.4	13.2
22	0.6	25.2	47	0.9	37.4
23	0.8	3.5	48	0.2	8.9
24	0.7	39.3	49	0.6	27.6
25	1.8	79.5	50	0.8	40.6

A

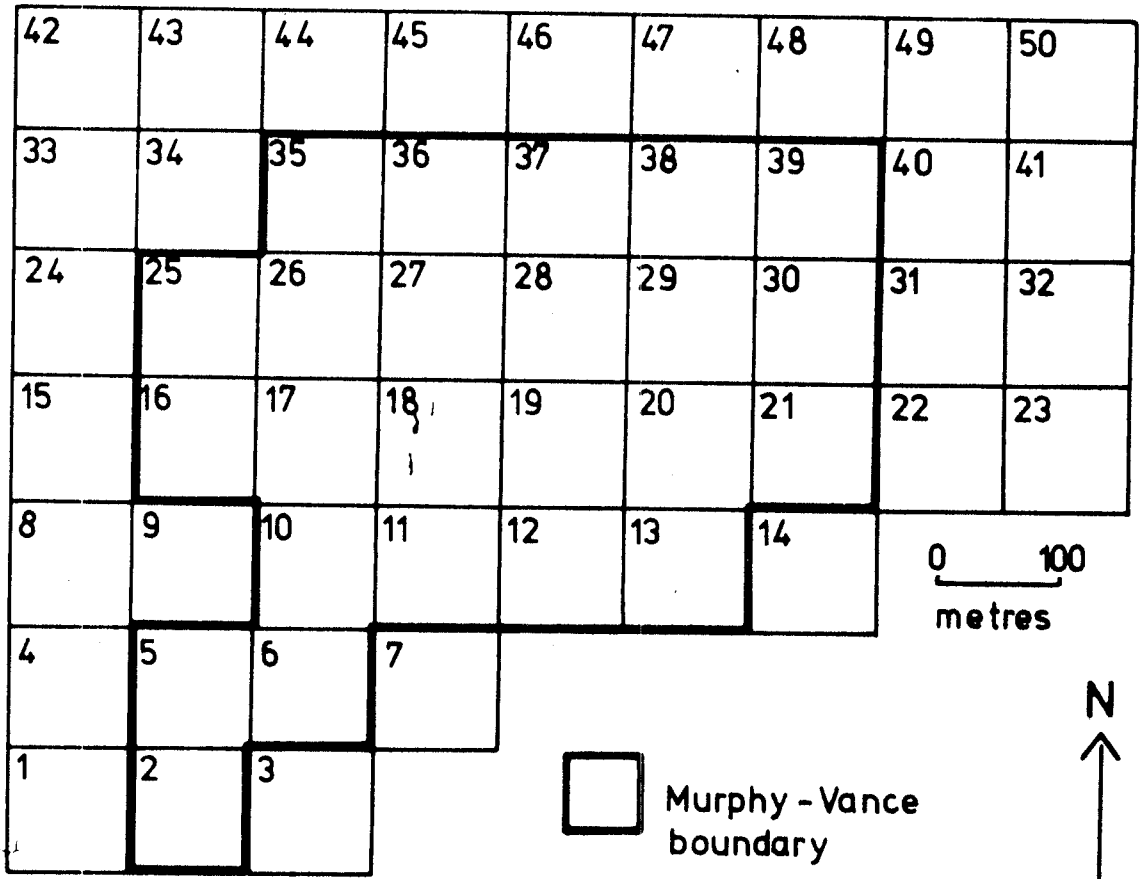

B

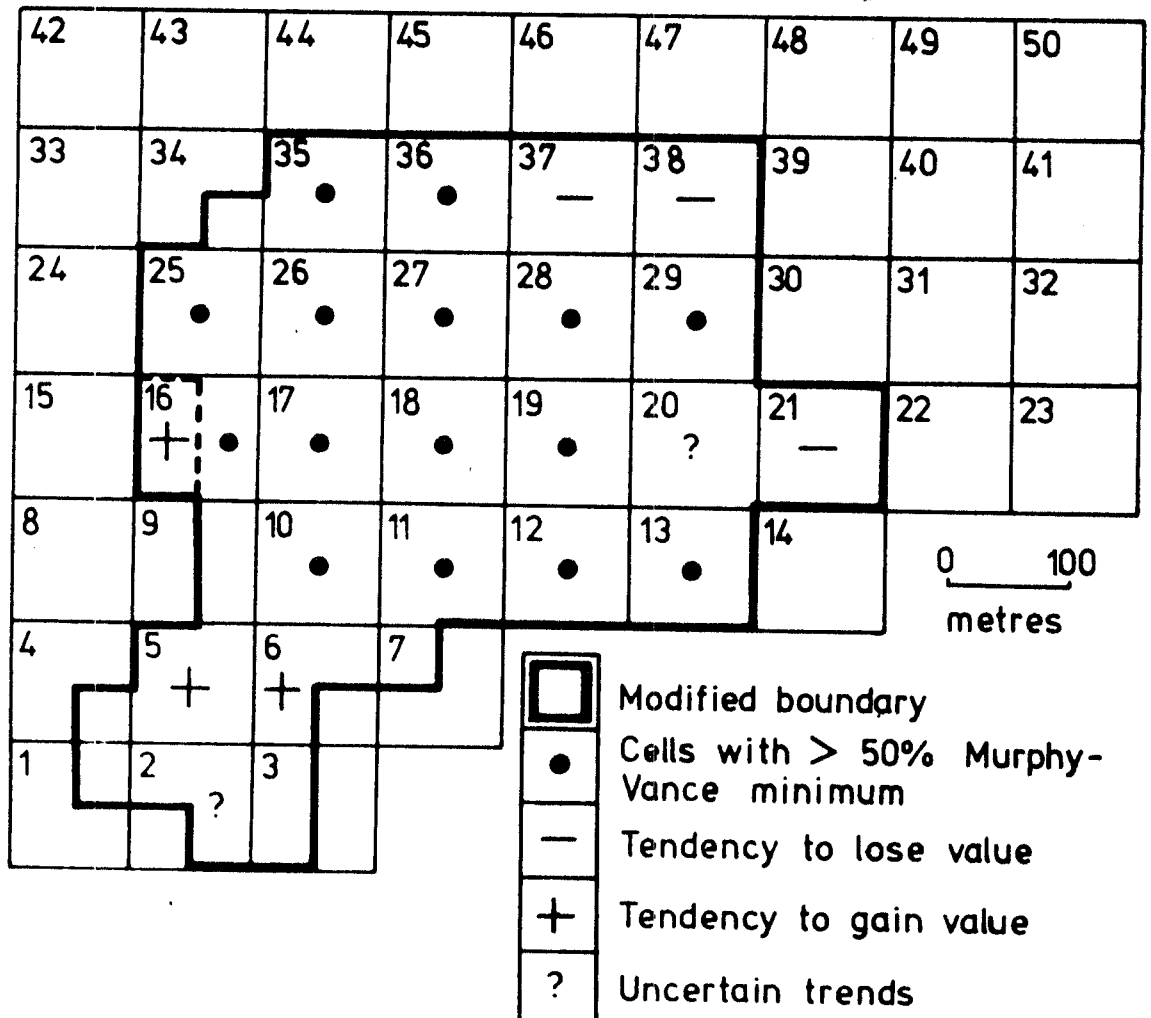

Fig. 13. Delimitation of central Sunderland by Murphy-Vance method.

The results show that of the 50 cells which made up the survey area, 24 cells satisfied in 1970 the minimum requirements laid down by Murphy and Vance. The values tabulated closely reflect the commercial importance of the cells. Only in a few cases do the calculations present serious discrepancies. These discrepancies can be attributed to the year the data were collected.

In 1970, the completion of the planned centre meant that some floor space had not yet been occupied. In the calculations, therefore, the 'vacant' category was high and C.B.I.I. and C.B.H.I. ratios correspondingly depressed (Cells 18 and 26). Conversely, other cells, after 1970, began to lose central business floor space as firms moved into more 'central' locations. In these cases, (Cells 19, 30 and 39) the 1970 figures proved too high. Ratios were recalculated for these exceptions, on the basis of "normal" post 1970 usage. The new figures are shown in brackets in Table 13 and indicated by asterisks. Fig.13 (A) maps the areal extent of the delimited C.A. of Sunderland according to the Murphy-Vance calculations and rules. Fig.13 (B) modifies the defined C.A. by considering (i) commercial change (growth and decline) after 1970, (ii) quarter cells where significant interval variations of land use were known to exist, and (iii) a nucleus or 'hard core' of cells with high ratios.

#### Validity of the delimited C.A.

The validity of the defined C.A. of Sunderland can be approached by comparison with other delimitation methods. Guidelines employed by the Board of Trade <sup>(10)</sup> in the delimitation of central areas lay the emphasis on retailing: "limits ... where shops give way to residential property or where lines of shops thin out and become interspersed with the private dwelling ..." (para. 43).

Fig. 14 portrays the "lines of shops" in central Sunderland. The arrangement of shop frontages shows the expected correlation with the alignment of the route network. In a general sense, the delimited C.A. after Murphy and Vance (Fig.13) agrees with this portrayal, although the exclusion of other commercial activities from consideration makes the delimitation in specific areas inadequate.

Other definitions of the C.A. are included on Fig.15. The boundary for official planning purposes is, the most extensive and obviously encloses a meaningful unit for planning. Its usefulness and acceptability for present geographical purposes, however, is limited. The area includes a wide range of land uses including parkland, inner

Fig. 14. Shop frontages in central Sunderland.

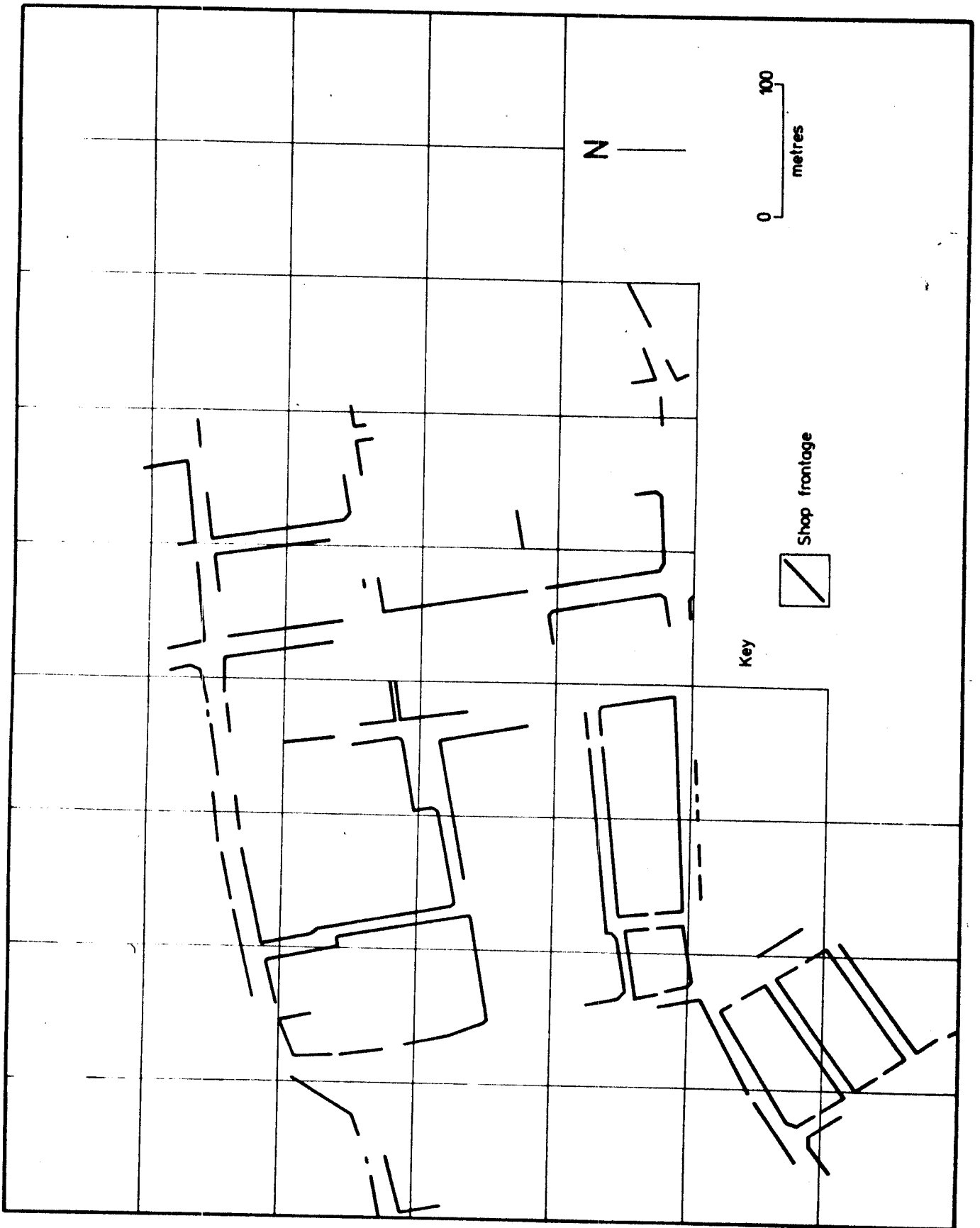

housing and industrial blocks. A more restrictive definition is required here to regionalise the commercial component of central Sunderland.

The Murphy-Vance definition is, therefore a more restrictive area and is shown for comparison, in relation to the 50 cell grid described in Chapter 4. From personal knowledge, it bears a close relationship with the writer's view of the C.A. of Sunderland. Furthermore, it approximates the limits of a C.A. of Sunderland as perceived by a sample of respondents.

Perceptual delimitations are interesting, recent and, as yet, little researched facets of C.A. study. <sup>(11)</sup> The 'average' line drawn on Fig. 15 was determined from replies of 52 undergraduate geography students. Each student was given a street plan and asked to delimit the C.A. of Sunderland, with or without field visit. The 52 responses showed areas of agreement and disagreement. The solid line in Fig. 15 shows a high degree of agreement along High Street West, Crowtree Road and Holmside where land use changes are abrupt. Less certain views on the boundary of the C.A. are indicated by the pecked lines. Considerable doubt was expressed (i) whether the Vine/Olive/Derwent Streets area can claim to be in the C.A. and (ii) which street marks the limit on the east side where land use change is gradual and where no marked barriers exist. (The results of the Murphy-Vance method confirms the uncertainty of these same two border zones). In this sense, the perception delimitation offers a reasonable definition of the C.A. A summary of the responses is given below:

- 15 responses included the Vine/Olive/Derwent Streets area in the C.A.
- 35 " excluded the Vine/Olive/Derwent Streets area from the C.A.
- 2 " were unsure and draw the line partly inside and partly outside
- 12 " used Frederick Street as the eastern limit
- 11 " " Norfolk Street " " " "
- 2 " " Nile Street " " " "
- 2 " " Villiers Street " " " "
- 3 " " Sans Street " " " "
- 9 " " John Street " " " "
- 9 " " Fawcett Street " " " "
- 4 " " West Sunnyside/ Foyle Street " " " "

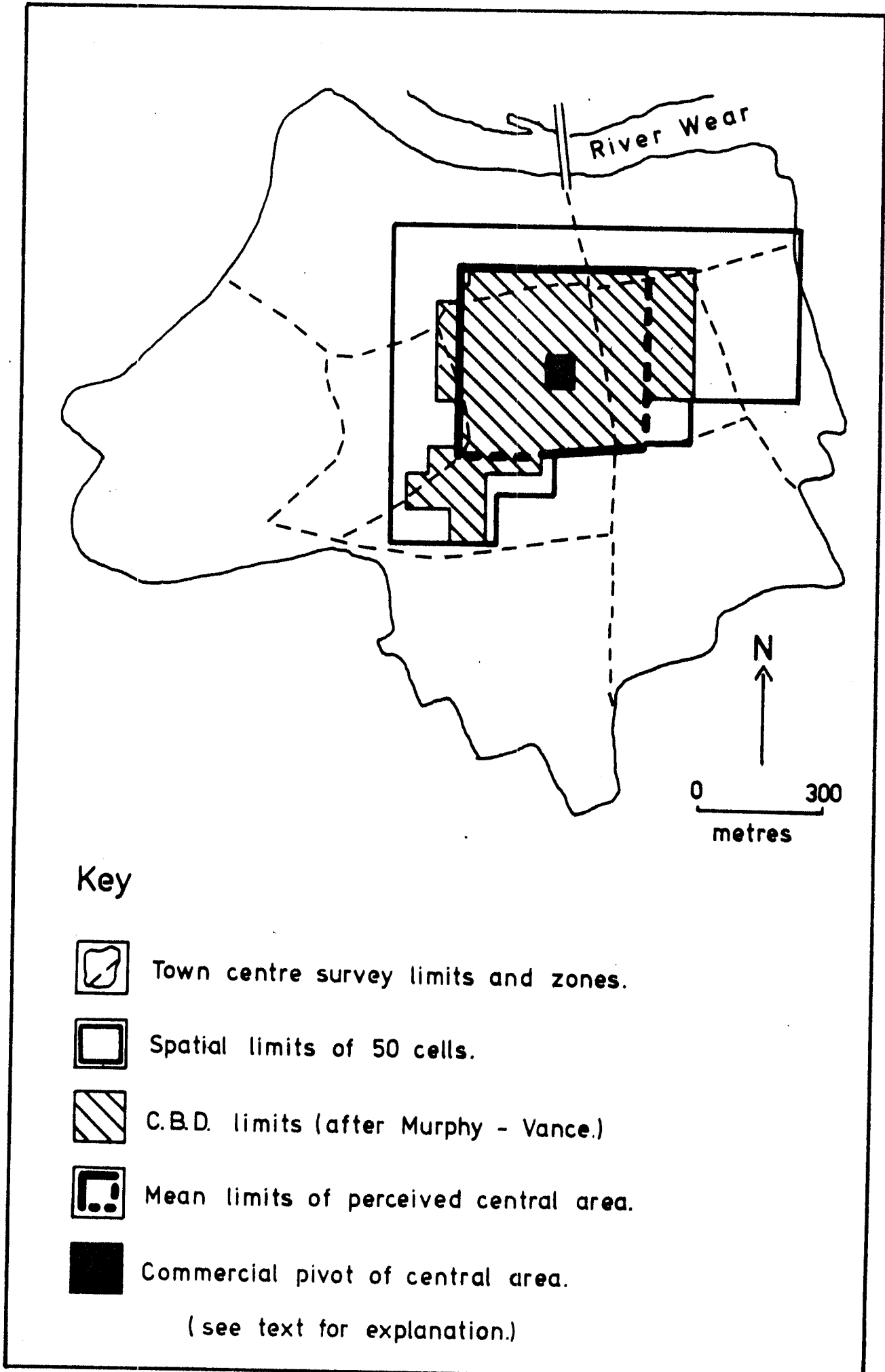

Fig. 15. Comparative delimitations of the C.A. in Sunderland.

Some characteristics of the C.A. of Sunderland

(i) Size

The C.A. of Sunderland, delimited by the Murphy-Vance method, covers a ground surface area of 28.2 hectares. This is considerably smaller than the average C.B.D. size <sup>(12)</sup> of the nine American cities studied by Murphy and Vance in 1954, but very similar to the average size of some other English C.B.D.'s in 1965. <sup>(13)</sup> Hypotheses on the comparative sizes of C.B.D.'s are still to be fully tested in the British context although several useful lines of enquiry are suggested. The lower economic standard of living in England and the related lower "intensity of commerce life" found in the English C.B.D. as compared to its American counterparts has been offered as probable reasons for the small size of the English C.B.D. <sup>(14)</sup>

The defined C.B.D. contains an overwhelming concentration of the commercial activity of central Sunderland. Of the 50 cells, the Murphy-Vance core contains 87.2 per cent of the retail space, 92.3 per cent of financial office space, 78.6 per cent of general office space, 61.1 per cent of 'service' space. It is, conversely, weakly represented in industrial (8.4 per cent of its space), warehousing (34.9 per cent) and institutions (54.2 per cent) uses.

The remaining area of the 50 cells, beyond the delimited C.A. covers 21.8 hectares and has, the characteristics of Preston's 'zone of Transition' and Horwood and Boyce's 'frame'.

ii) Shape

Although sophisticated measure of shape exist no attempt has been made to compute shape characteristics of C.A.s or C.B.D.s so far as the writer is aware. <sup>(15)</sup> However, a wide range of descriptive terms have been used, starting with Hartman's contribution on the shape of the C.B.D. <sup>(16)</sup>

Descriptions of the shape of C.A. are made difficult by: (a) the lack of precision of the boundaries which are often zones rather than lines, and (b) their continuously shifting nature. Various aspects of shape such as compactness and elongation can be considered if precision in delimitation is achieved. These two measures are defined briefly <sup>(17)</sup> and computed for the C.A. of Sunderland at five time periods to demonstrate their potential.

Compactness can be considered intuitively as the extent to which an area is grouped or packed around its central point. It can be defined mathematically as:

$$C = \frac{D}{\sqrt{2 \iint_A r^2 dA}}$$

Where C = Compactness coefficient

A = The shape of the area

D = Area of the shape

dA = Small element of the area A.

to range from 1.00 (maximum compactness, as found in a circle) to 0.

Elongation is a property closely related to compactness. Lack of compactness may result from its elongation which in turn gives an indication of its orientation. Many of the terms making up the expression for a coefficient of elongation are the same as those which are required for the coefficient of compactness. It is, therefore, possible to combine the calculation of elongation with that of the calculation of compactness with the addition of a few extra steps.

The changing shape of the C.A. in Sunderland can be approximated by polygons for five time periods: 1850, 1900, 1900 and 1970 and 1980. These are represented diagrammatically below. Accepting the impossibility of precise delimitation, they represent approximate shape characteristics of the C.A. as determined by historical research (Chapter 3) and more contemporary findings (Chapter 4). They are furthermore, adequate to demonstrate the application of measures of compactness and elongation and comment on the nature of the changing shape of a C.A. in Sunderland.

In 1850, a strong east-west alignment of the C.A. existed as determined by High Street West and its commercial dominance then.



Compactness of this shape is .517 and its elongation .989.

By 1900 the shape of the C.A. had been transformed into a cross (ideal shape according to Murphy and Vance) by the influence of road and rail lines south across the river and High Street. The compactness

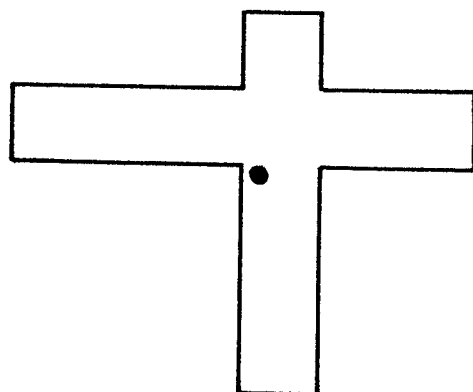

coefficient was now .717 and the elongation figure was .816. (i.e. increasing compactness and decreasing elongation). Some 'discard' on the east side of High Street had led to the 'withering' of the C.A. in that area.

Expansion of commercial activity into streets adjoining Fawcett and High Street West upto 1950 produced some consolidation in the east and extension in the west. The compactness and elongation indices were .765 and .870 respectively for this shape.

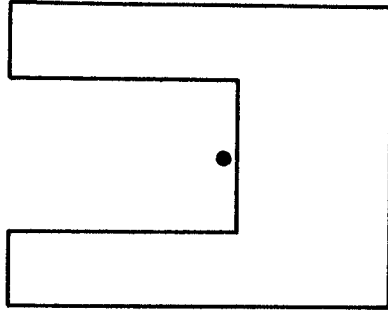

The redevelopment of the mixed central area and its conversion into retail space produced a very compact and consolidated C.A. by 1970. Maximum compactness (.965) and minimum elongation (.600) were recorded.

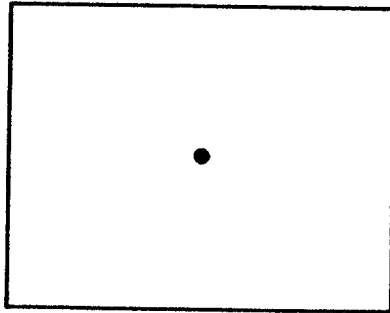

Finally, looking ahead, the economic pressures for more central area space is already causing overspill into former residential streets in the south west which have all the features of assimilation. Compactness is, therefore, beginning to fall (.915) and elongation increasing again (.679)

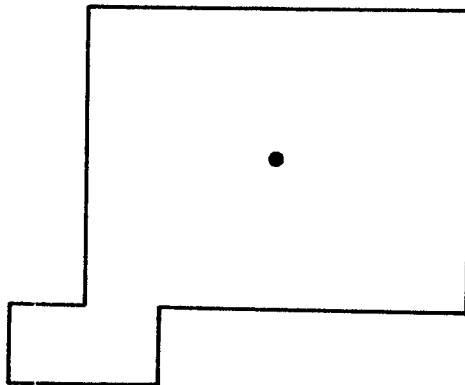



Fig. 16. Age structure of central Sunderland.

## (iii) Age

The spatial dynamics of commercial activity in the C.A. has been influenced by the age and condition of the physical stock of properties. Just over one third of the land area of central Sunderland is composed of buildings (34.3 per cent of the 50 cells, 35.2 per cent of the delimited C.B.D.). The remainder is occupied by streets <sup>(18)</sup>, railways, open and unused spaces.

Within the building stock there are wide variations in age and condition. The age structure of central Sunderland is shown in Fig.16 which was constructed from data collected from the local planning department and from field work. To establish whether the C.A. shifts in Sunderland caused or were caused by the physical condition of the property, is a difficult task and needs considerable further research. There is no doubt that functional obsolescence and physical condition are associated <sup>(19)</sup> and the present research in the C.A. of Sunderland confirms this conclusion.

C.A. change in Sunderland is related to property decay. The oldest (and most unsound, structurally) properties are found mainly on east sides of the C.A. Together with others, they constitute the so-called 'frame' of the C.A. and accommodate a miscellaneous collection of 'non-central' uses. These properties also, experience high rates of commercial turnover. (See Chapter 6)

The commercial attractiveness of the present retail core is based on the functional newness of the property as well as its locational advantages. The migration of firms from the older peripheral 'frame' properties into the new units of the core area is a key process in the changing shape of the C.A. of Sunderland.

### Land-values <sup>(20)</sup>

The two and three dimensional patterns of land use in central Sunderland are the outcomes of site selections in a competitive market. This fact is proved by the correspondence that exists between the value of land and the pattern of C.A. land use.

Land values in this section refer to gross rateable values, which have been totalled from current valuation lists for all separate establishments in the 50 cells. The block diagrams (Fig.17), on which the existing street plan is superimposed, show the high values of a few central cells. The pattern is essentially a product of processes which have (a) their origins in the nineteenth century (Chapter 3) and

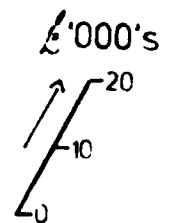
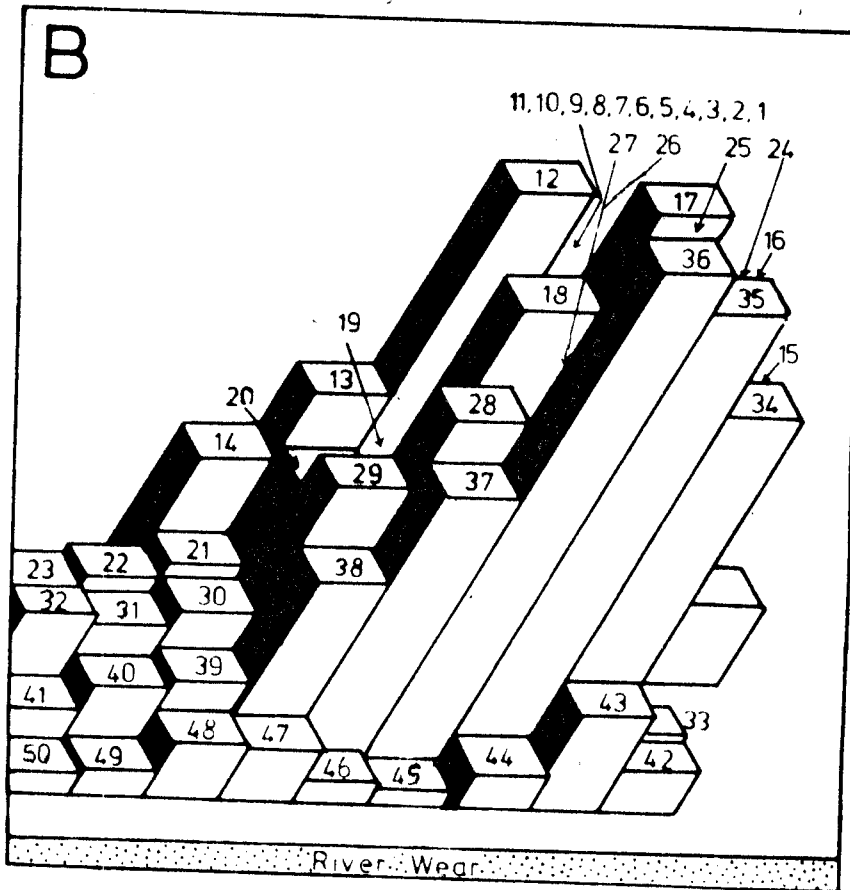
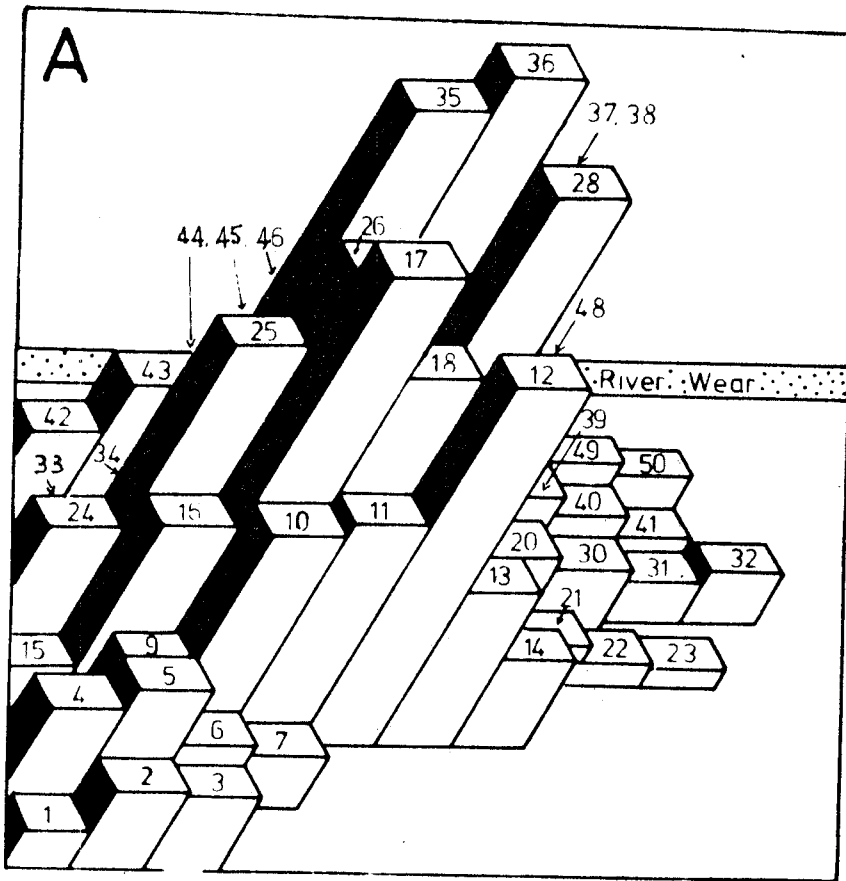

Fig. 17. Land values in central Sunderland in 1975.

(b) their stimulus in twentieth century planning decisions. Two further spatial characteristics can be noted from the diagrams. Firstly, the maximum land values are accumulated in cell 36, thus confirming the theoretically expected highest values in the more accessible locations. Secondly, the arrangement of land value throughout the C.A. is asymmetrical. The two perspectives offered show that the gradients on the north and south sides of the core area are steepest. This can be attributed to the barriers referred to above. The gradient on the east side, however, is more gradual; and to the west, in which direction growth tendencies are most likely, the land value gradient is again less steep. Also, the 'building up' of land values in cells 4 and 5, reflects the commercial increases in the south western corner of the core. The eastern limit of the delimited C.A. can be identified along cells 22 - 30 - 48 where functional and physical characteristics keep values low.

### Internal Structure

#### (i) Functional segregation

The delimitation exercise is a useful prelude to the investigation of the internal structure of the C.A. of Sunderland. A triangular graph is presented (Fig.18) to show the ways three 'central business' land uses occur in the 50 cells of the grid. The three uses are: offices, shops and services. A point fixes the relative position of each cell with respect to percentages of floor space under each use. Data were extracted from the same source as for the delimitation exercise.

The three way functional relationships are graphically described. It is clear that about 70 per cent of the cells are dominated by one of the three activities, thus demonstrating the tendency for urban functions to segregate in the modern C.A. In the remaining 30 per cent of the cells, a variety of land use combinations are found.

Following the standard method of interpretation of triangular graphs (21) the cells can be grouped into three categories on the basis of relative scores:

Group 1 (F). Those cells characterised by the dominance (i.e. more than 60 per cent of total floor space) by one function and the relative weakness (less than 20 per cent) of the other two functions.

(a) retailing in cells: 5,9,10,11,12,18,25,32,35,36,37,38 and 48.

(b) offices in cells: 20,46,47 and 50.

(c) services in cells: 3,6,7,8,15,22 and 45,

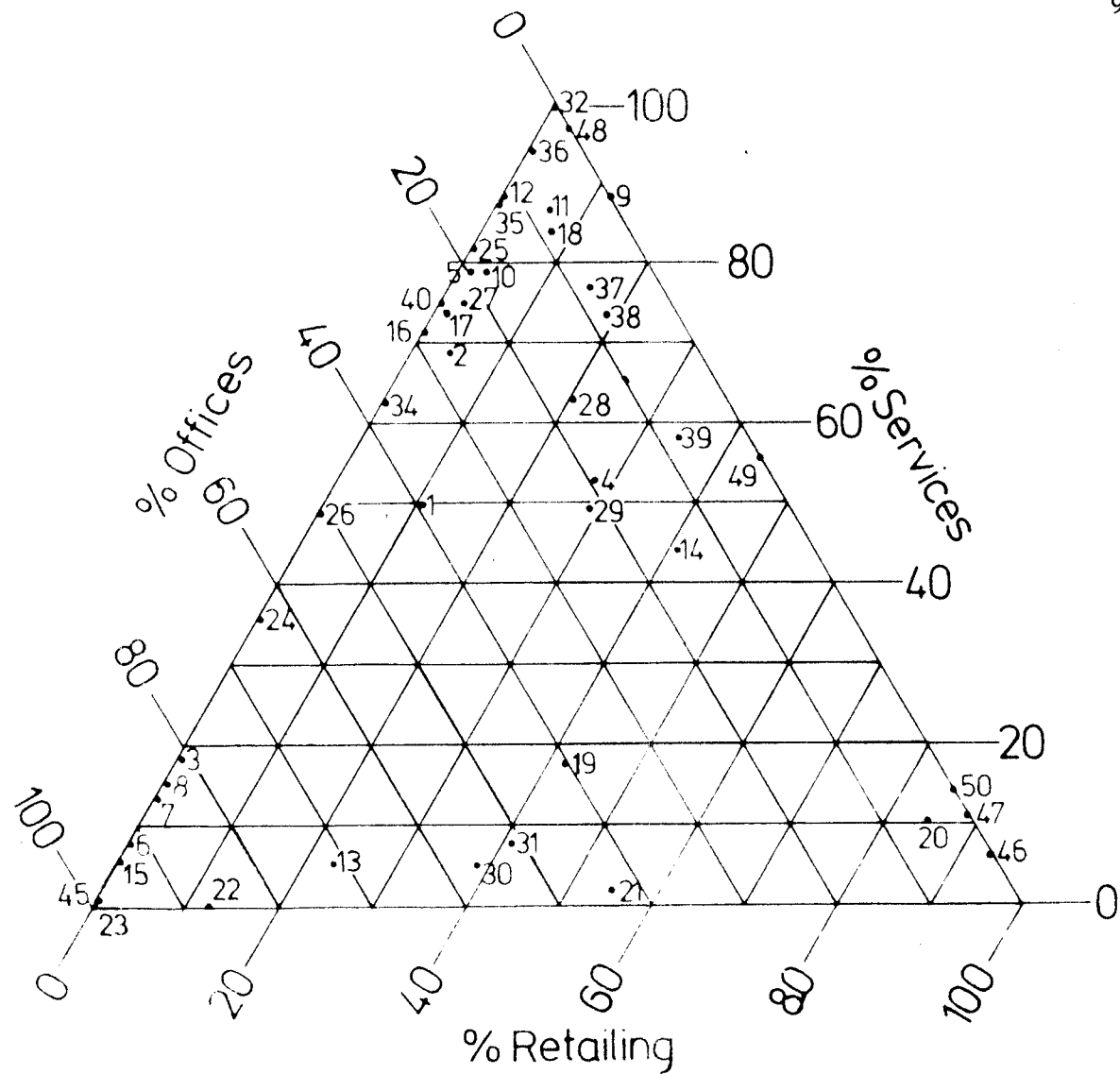

Fig. 18. Triangular graph to show the relative concentration of 3 central area uses.

Group 2 Those cells characterised by one function being very small (less than 15 per cent of total floor space).

15%:

- (a) retailing in Nos. 6,13,15,20,21,22,23,30,31,33,41,42,43,44,45, 46,47 and 50.
- (b) offices in Nos. 1,2,3,5,6,7,8,9,10,11,12,15,16,17,18,22,23,24,25, 26,27,32,33,34,35,36,40,41,42,43,44,45,46,47,48, 49 and 50.
- (c) services in Nos. 9,11,12,14,18,20,32,33,35,36,37,38,39,41,42,43, 44 and 48.

Group 3 Those cells characterised by an even mixture of three functions: (none more than 40% or less than 15%):

Cells: 19,28 and 29.

(Fuller details of both relative and absolute values for each cell is given in Appendix 15).

The segregation of urban functions is a normal feature of C.A. structure. Of the three major functions selected, services were found to be the least segregated. Their dispersal over most of the grid reflects their miscellaneous nature and varying locational requirements. Offices and retailing, on the other hand, are relatively more concentrated and exhibit a pattern of spatial specialisation. Fig.19 contains detailed information for both the office function (A) and retailing (B). The shaded area represents that part of the C.A. where the two uses achieve a discernible measure of dominance. The critical values for offices and retailing were arbitrarily fixed at 20 per cent and 60 per cent, respectively, to reflect their relative importance in the floor usage of the C.A. Notwithstanding, a strong spatial separation of a retail and office quarter is recognisable. Retailing dominates the C.A. in the western half and occupies properties which have been purpose-built to be in a good location to serve the residential areas beyond. Offices achieve a dominating position in the eastern half of the C.A. in properties which, externally at least, are the original residential units. The zone of separation lies along the Fawcett and John Streets area, and confirms other empirical conclusions that the transport frame is a critical factor in shaping C.A. morphology. (22)

(ii) Internal structure of the delimited C.A.

The investigation of the internal structure is now refocussed using three complementary approaches. Firstly, some of the assumptions about

A

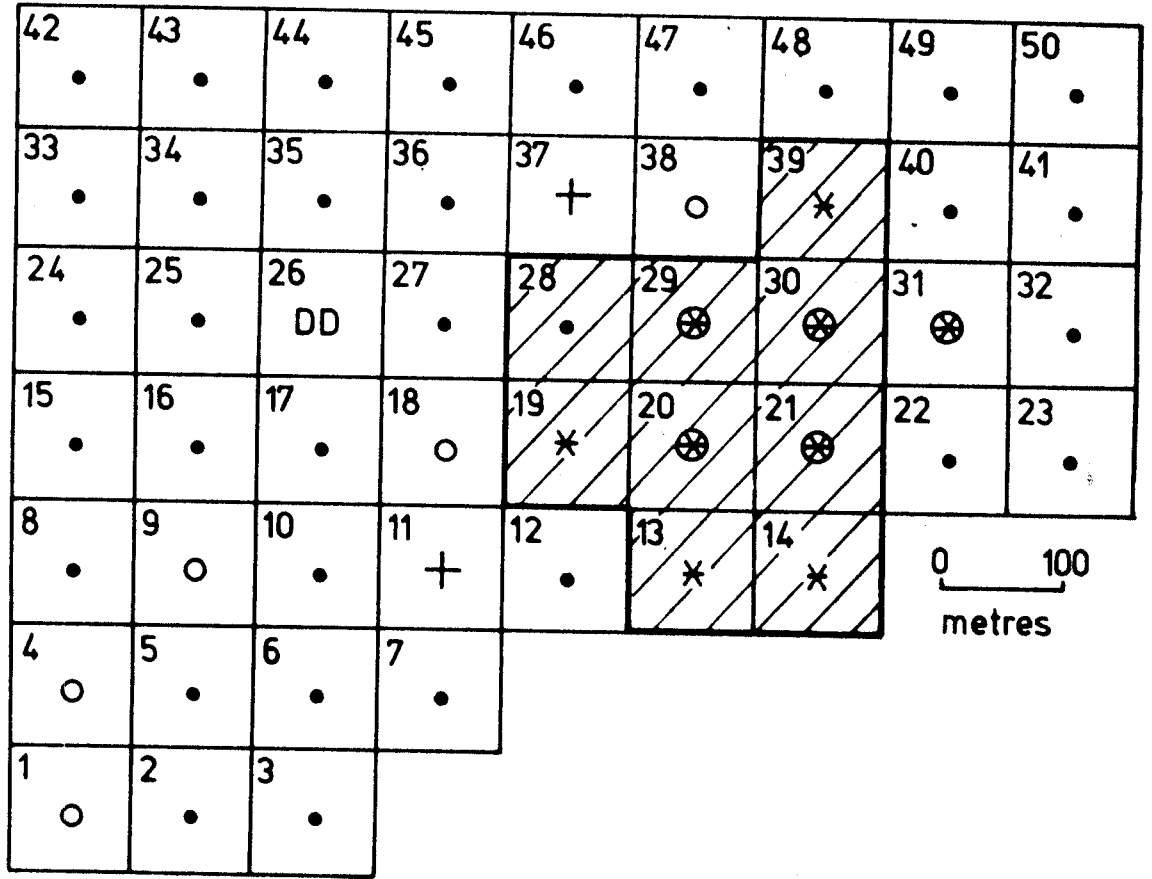

B

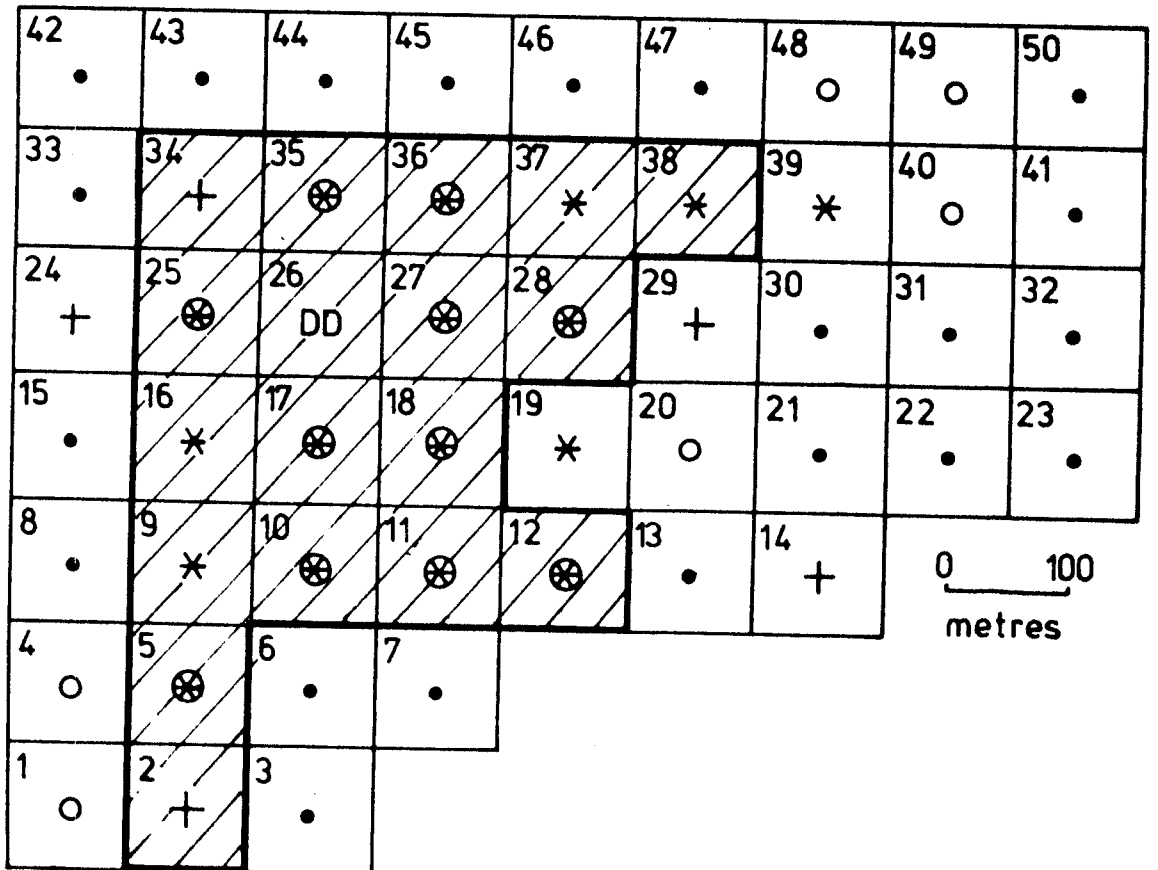









Fig. 19. Comparative data on offices (A) and shops (B).







## A. Offices.

Floor space in square metres

	> 2000
	1001 - 2000
	501 - 1000
	250 - 500
	< 250
	Office use > 60% of all central use space
	Doubtful data

## B. Retailing.

Floor space in square metres

	> 4000
	2000 - 3999
	1000 - 1999
	500 - 999
	< 500
	Retailing > 60% of all central use space
	Doubtful data

the spatial patterning of C.A. land use is tested in the delimited region. Secondly, the effect of distance in land use behaviour is examined in relation to a number of control points. Thirdly, the vertical dimension of the C.A. is considered by referring to land use structures at different floor levels.

The usual control point, from which land use patterns in central areas are investigated, is the Peak Land Value Intersection Point (P.L.V.I.P.). This is the point at which land values reach their maximum. Normally, it is located at or near the intersection of major routes where accessibility is highest. The assumption that urban functions arrange themselves in relation to their ability to meet the higher costs of sites near the P.L.V.I.P. is basic to much theoretical and empirical literature on C.A.'s.

Fig. 20 fixes the P.L.V.I.P. for the C.A. of Sunderland at the intersection of cells 36,37,27 and 38. Its eccentric location reflects the assymetrical distribution of land values in central Sunderland which was noted above. Use of the P.L.V.I.P. in Sunderland for correlating land use change in zones away from that control point, therefore, may not be very appropriate.

Instead of relying on a single point, an alternative approach is suggested based on a single control cell (cell No.18). Selection of this cell in central Sunderland has been determined by reference to three criteria:

- (a) it contains the centroid (i.e. the centre of gravity of the area) of the defined C.A.
- (b) it contains the centre of gravity of all retail space in the 50 cells. (23)
- (c) it contains the centre of gravity of all commercial establishments in the 50 cells. (24)

All these three points are, found in cell 18, which is now called the commercial pivot of the C.A. It contains the new shopping precinct centred on Market Square and the peak pedestrian flows of all the C.A. From evidence presented in Chapter 7, this cell possesses the attributes which many commercial establishments look for in site selection policies. A final consideration is the choice of cell 18 as the pivot from which land use is measured, is that it allows the use of a symmetrical arrangement of cells, in concentric 100 metre zones.

The spatial pattern of land use in the C.A. will now be examined in relation to horizontal distance away from this pivot cell.

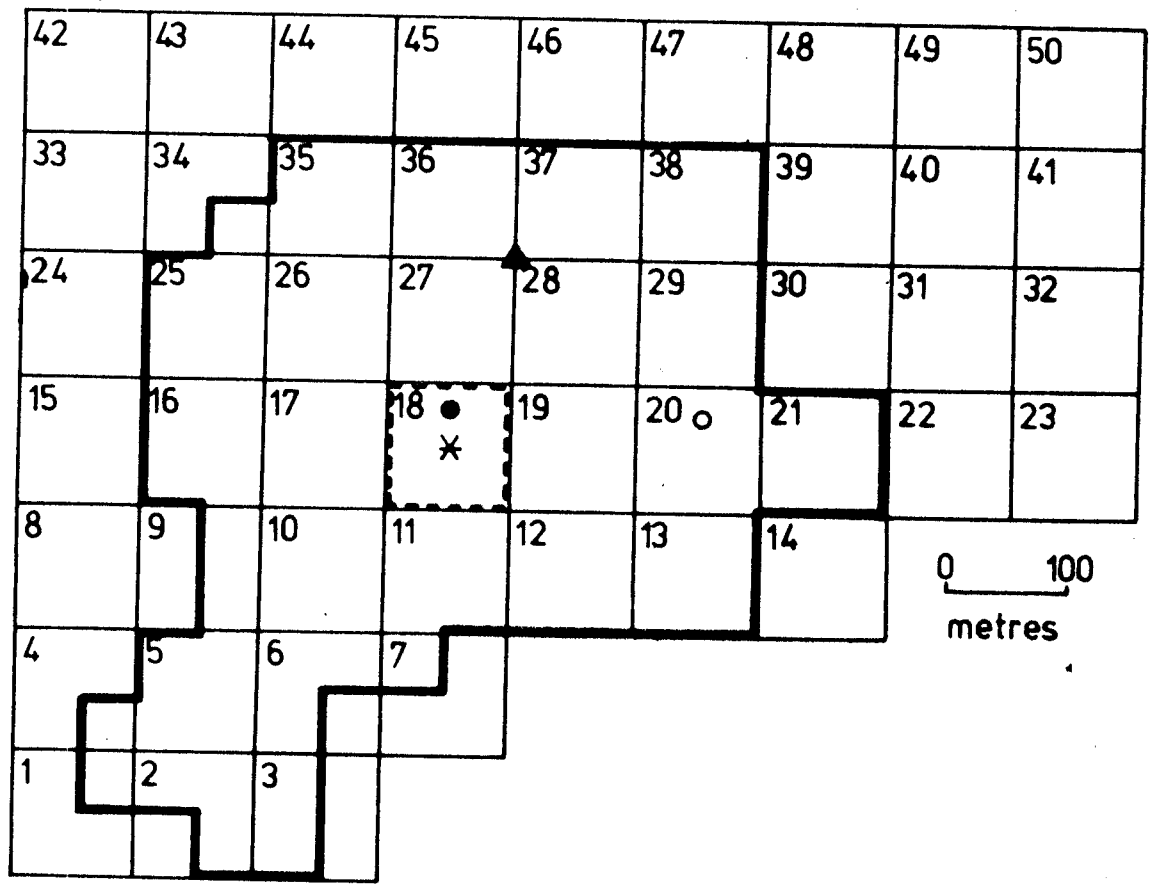

### Key

▲	PL.V.I.P
●	Centre of retailing space
✱	Centroid
○	Centre of office space
□	C. B. D. ( Murphy - Vance )
□	Commercial pivot

Fig. 20. Some control points in the C.A. of Sunderland.

### Land Use by Zones

Fig. 21(A) shows the four 100 metre zones in relation to the pivot cell. Zone A contains 9 cells including cell 18 and eight others which lie within 100 metres of cell 18. Zone B contains 14 cells and does not completely surround Zone A because of the interruption of urban park land. This zone is made up of cells within 200 metres of the commercial pivot. Zone C, within 300 metres of the pivot cell contains 19 cells. Finally, Zone D, more than 300 metres away from the pivot, is found in the extreme east of the survey area and contains 8 cells. Zone D contains features which are associated with 'discard' whilst Zone C contains features of 'assimilation', 'discard' and 'general inactivity.'

The hypothesis that land use changes with increasing distance away from the pivot area can now be examined from data of floor usage. Use of floor space was classified into eight major categories: retailing, offices, services, residential, Institutions, vacant, industrial and warehousing. The floor space under each use at all levels was totalled for the four Zones. Then percentages of the floor space under each of the eight land use categories were computed for each zone. The results are presented in percentage bar graphs in Fig. 20(B) in such a way as to facilitate comparisons between the four zones.

The results of this analysis confirms other empirical work of land use patterns in central areas and generally agree with the expected patterns. Table 14 contains the results and it is followed by a summary of the main features.

Table 14: Floor space in central Sunderland by zones

<u>LAND</u> <u>USE</u>	Zone A		Zone B		Zone C		Zone D	
	A	P	A	P	A	P	A	P
Retailing	55,414	58.4	52,365	39.7	13,034	9.3	2,264	4.7
Offices	5,861	6.2	10,803	8.2	8,860	6.3	445	0.9
Services	18,032	19.0	23,141	17.5	15,123	10.8	6,372	13.3
Residential	3,828	4.0	5,400	4.1	13,026	9.3	2,744	5.7
Institutional	0	0.0	1,988	1.5	22,574	16.0	722	1.5
Vacant	5,974	6.3	18,314	13.9	22,994	16.3	6,408	13.3
Industry	98	0.1	9,424	7.1	27,214	19.3	15,453	32.1
Warehousing	5,742	6.0	10,581	8.0	17,879	12.7	13,667	28.4
Total	94,949	100.0	132,016	100.0	140,704	100.0	48,075	100.0

A = Actual space in sq. metres

P = Percentage of all space in each zone.

**A**

Fig. 21. Land Use by Zones in Central Sunderland

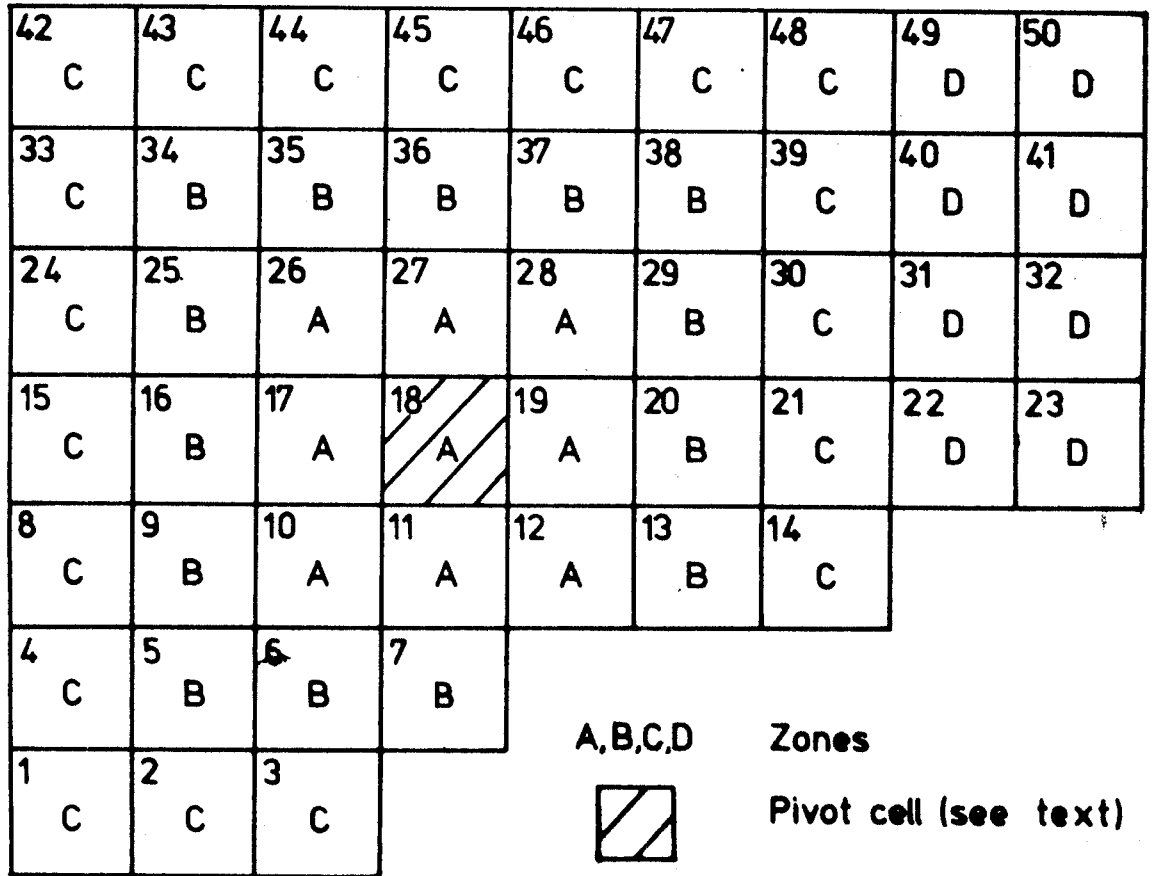

**B**

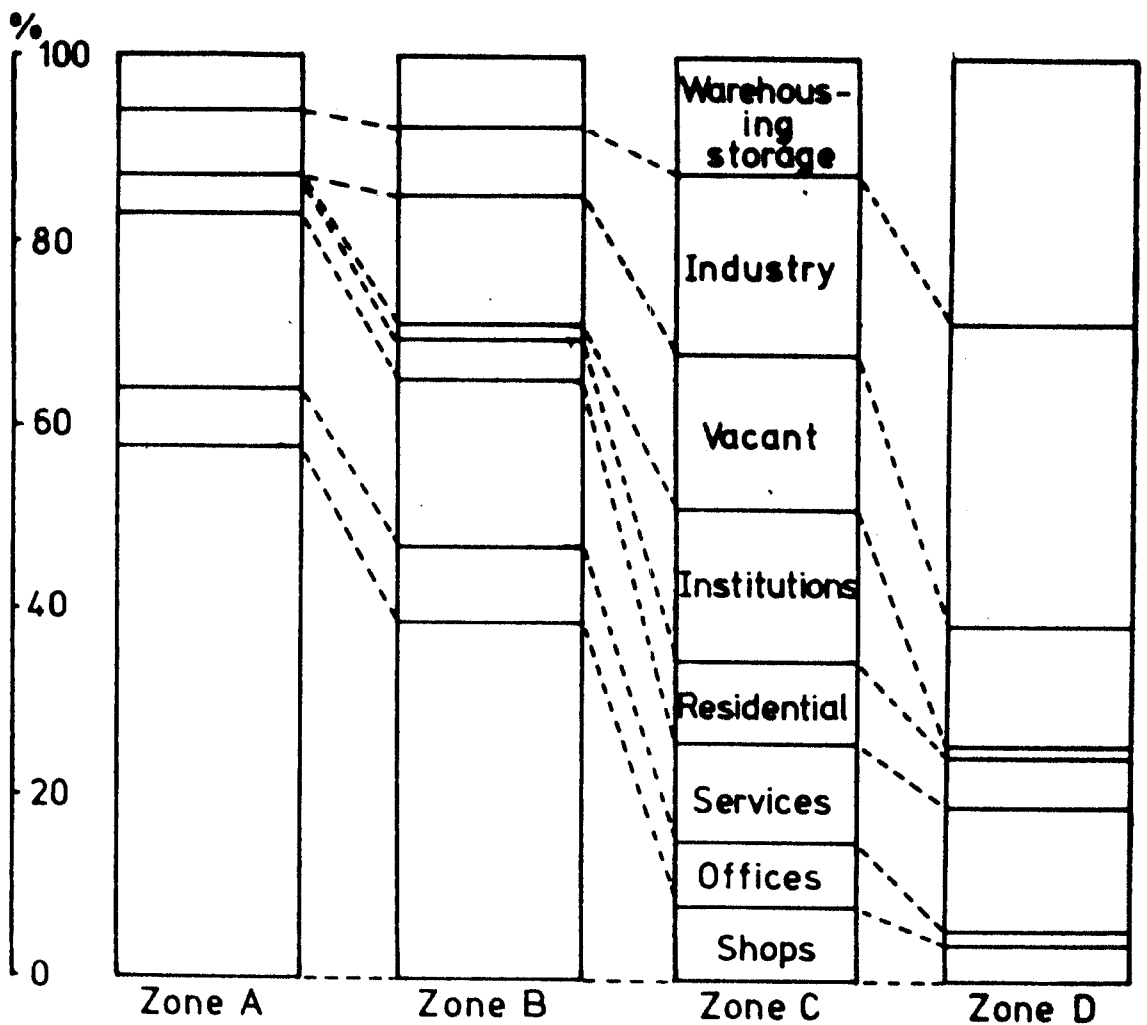

Fig.21. Land use by zones in central Sunderland.

Zone A:

Zone A is dominated by a single land use to a greater extent than any other zone, retailing taking up 58.4 per cent of all floor space in this zone. A further 23.6 per cent is occupied by offices and services. The remaining space is taken up by non-central activities with vacant and storage space being the most important. Residential use becomes important only above first floor level.<sup>(25)</sup> Institutional and industrial use are virtually excluded from Zone A.

With increasing distance away from the pivot cell, important land use changes occur. Retailing is still the most important floor space user in Zone B, where accessibility remains easy for pedestrians, but the relative importance of retailing to other users has dropped markedly to just below 40 per cent. Some cells in Zone B, particularly to the south and west, record symptoms of active assimilation, such as new retail, office and service activities, and more investment and structural improvement. Office use, on the other hand, has increased slightly mainly due to the non-financial element. Services still claim the second largest area of floor space with 17.5 per cent of the total. Non-central business use has increased in Zone B to 44.6 per cent of all space. Vacant space remains the third highest 'use' in this zone. Warehousing/storage, industry and institutional uses have all recorded significant increases. Residential use has remained constant.

Zone C covers the more peripheral areas of central Sunderland. Only one quarter of the floor space is devoted to three 'central business' users. Retailing is only a minor user (less than 10 per cent), not being attributed by the business potential of Zone C. Offices have decreased slightly to about the same relative importance they reached in Zone A. Services, however, are only one half as dominant as in Zone A. The four largest land users in Zone C are, instead, industry, institutional and vacant and warehousing. Residential use has doubled its relative position since Zone B.

Zone D, as Fig.20(B) shows is restricted to the extreme east of the study area, covering only Sans and Villiers Streets and the eastern end of High Street West. Offices are virtually excluded; the floor space given over to retailing and services is higher than expected due to the influence of a single large establishment in each core.<sup>(26)</sup> Warehousing, industry and vacant cover nearly three quarters of all floor space in Zone D.

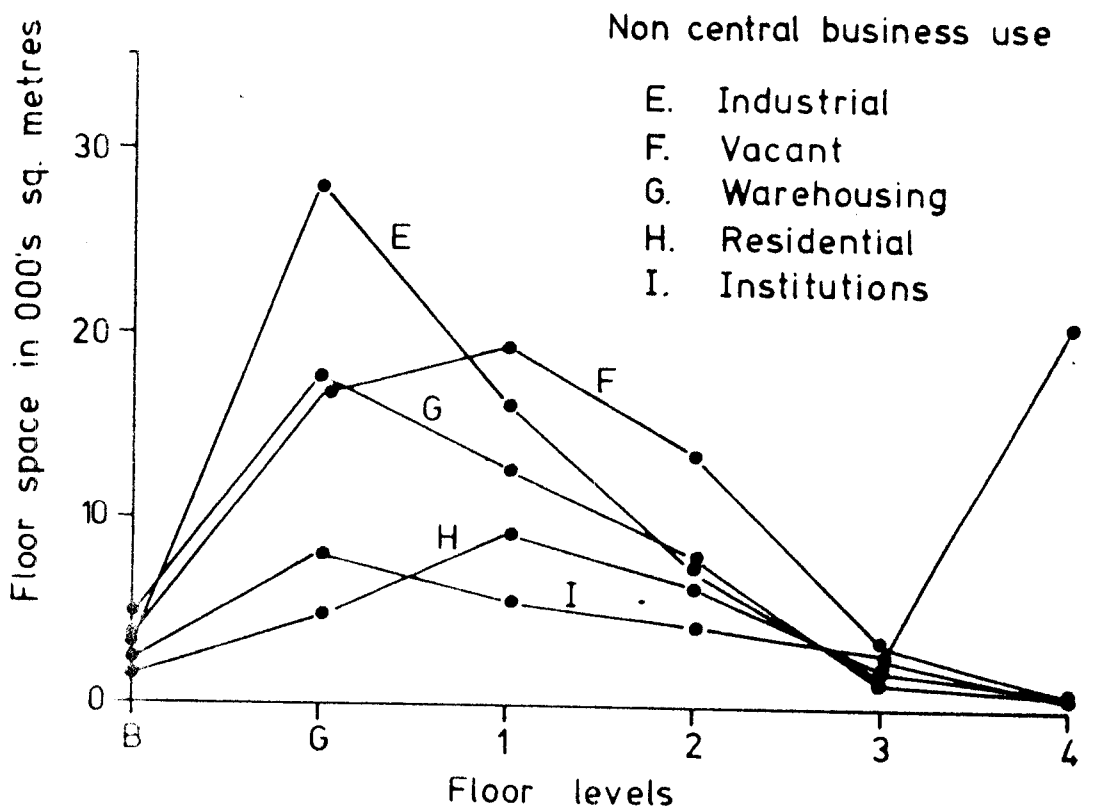
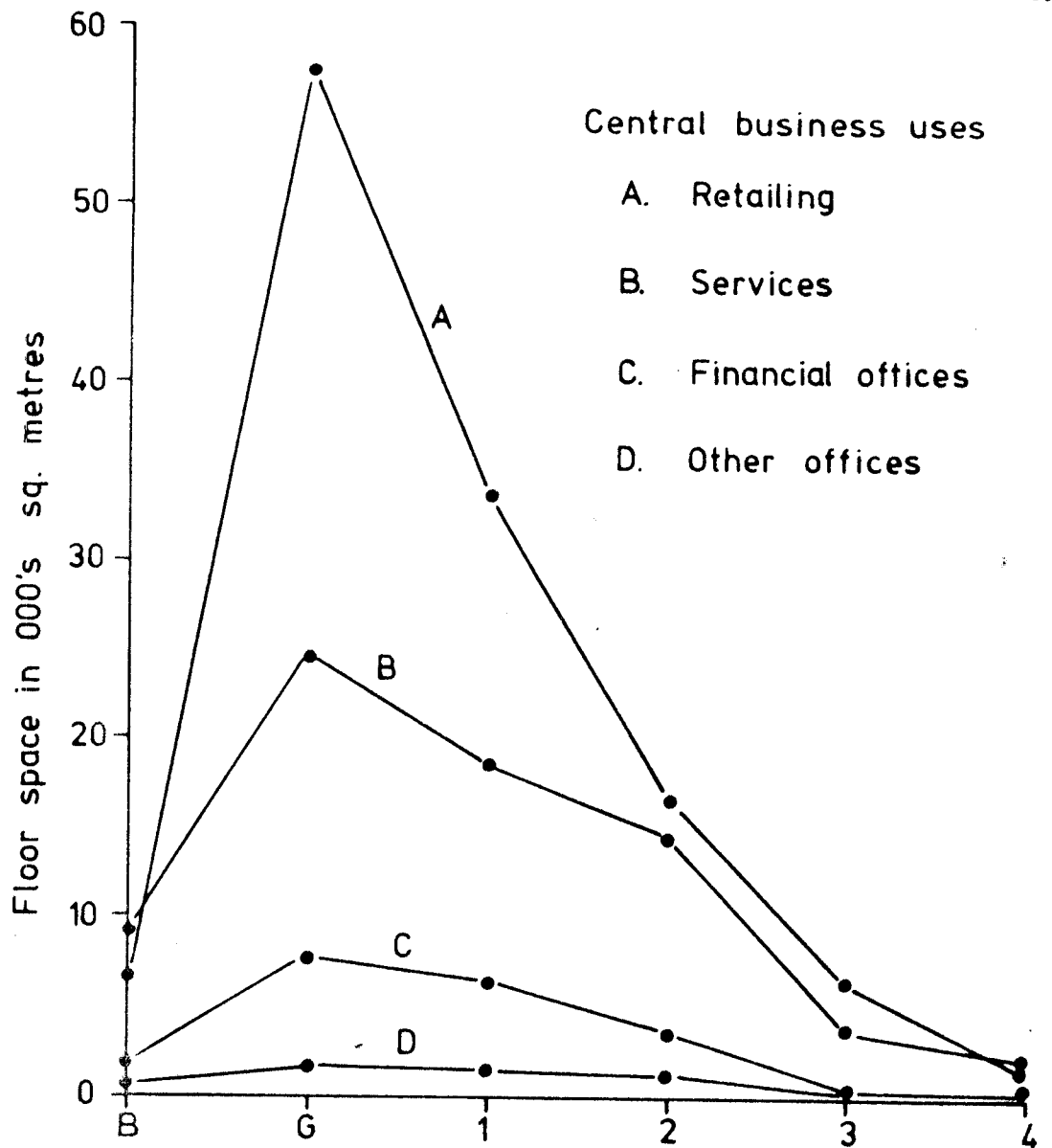

Fig. 22. Land uses in relation to floor level, central sunderland.

Land use by floor levels

So far only the horizontal changes of land use in the C.A. has been investigated. However, C.A.'s have an important three-dimensional component with land uses spatially arranged vertically as well as horizontally. The assumption that urban land uses compete for vertical space is examined by referring to six floor levels: basement, ground floor, first, second, third and fourth floors.

The total floor space for the 50 cells in 1970 was 443,879 m<sup>2</sup>. Of this, 7.4 per cent is classed as 'basement', 37.6 per cent 'ground', 27.6 per cent, 'first-floor', 16.8 per cent 'second floor', 4.7 per cent 'third floor' and 5.9 per cent 'fourth floor' and above. The distribution of space given to 'central and 'non central' use for each of the floor levels is provided in Table 15.

Table 15: Land use in central Sunderland by floor levels

<u>LAND USE</u>	<u>FLOOR LEVELS</u>						<u>Total</u>
	<u>B</u>	<u>G</u>	<u>1</u>	<u>2</u>	<u>3</u>	<u>4</u>	
<u>"Central"</u>							
Retailing	6,404	57,590	38,885	16,749	6,320	1,556	122,504
Offices	2,634	9,203	7,669	4,705	437	0	24,648
Services	9,119	24,922	18,224	14,903	3,937	1,857	72,962
<u>"Non-central"</u>							(220,114)
Residential	1,475	4,950	9,041	6,435	2,042	21,657	45,600
Schools	2,188	8,168	5,656	4,203	2,275	0	22,492
Vacant	3,178	16,665	19,123	13,492	3,289	601	56,348
Industry	3,052	27,997	16,177	7,200	1,365	0	55,791
Storage/ Warehousing	4,650	17,461	12,749	6,722	1,244	708	43,534
							(223,765)
<u>Total</u>	<u>32,700</u>	<u>166,956</u>	<u>122,516</u>	<u>74,409</u>	<u>20,909</u>	<u>26,379</u>	<u>443,879</u>

The behaviour of each major land use with respect to floor levels is graphed in Figs. 22 and 23. Fig.22 distinguishes, for the sake of clarity, between four 'central' and five 'non-central' business uses. In the 'central' category, offices have been subdivided into 'financial' (eg. banks, building societies etc.) and 'other' (eg. professional and general commercial offices). The graphs show the absolute dominance of retailing in the commercial structure of the C.A. and the relative importance of the other categories. Appendices 16 and 17 give supplementary

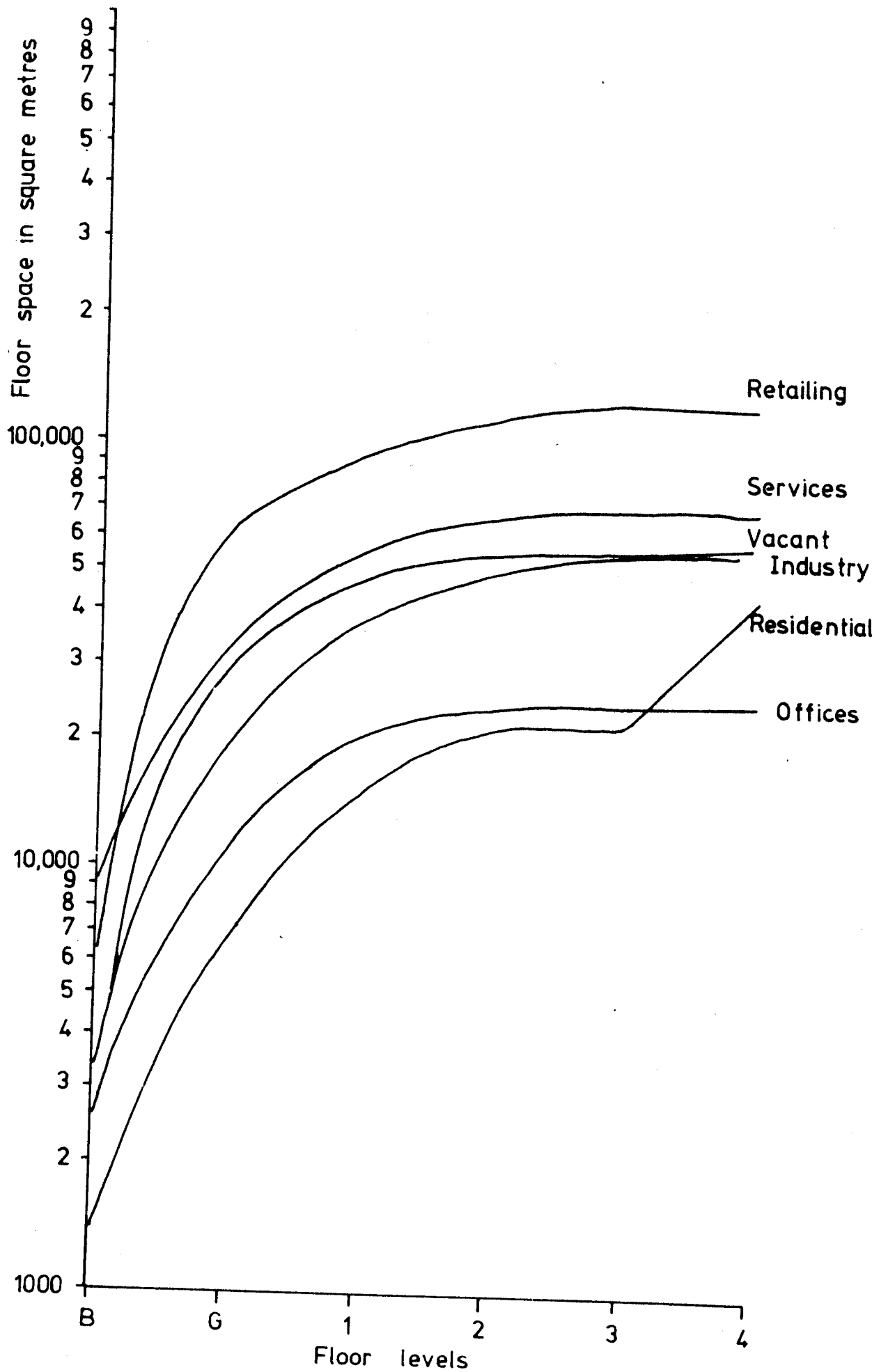

Fig. 23. Cumulative Rates of change in land use at different floor-levels.

details of land use by floor levels for the core (i.e. d cells which fell into the Murphy-Vance C.B.D.) and the extra core (i.e. the rest of the cells in the 50 cell grid), and each individual cell.

Both graphs and tables confirm many expected characteristic features of urban land use behaviour. Firstly, all land uses, with the exception of 'vacant' and 'residential' reach their maximum space at ground floor level. Secondly, the space at first and second levels for each use is greater than at basement level for the same use. Thirdly, floor space in all uses, except residential, shows a noticeable drop after third floor level, thus suggesting an effective upper limit on the C.A. Fourthly, residential is the only use to dramatically increase in levels four and beyond.

Urban economic theory has traditionally <sup>(27)</sup> stressed the role of distance away from the centre of towns on urban uses. The less researched aspect of changing urban use with height is more pertinent in this study.<sup>(28)</sup> Results of the vertical arrangement of C.A. land use in Sunderland confirm that some uses cannot effectively compete for the more desirable ground floor locations and are relegated to upper floors. However, it is necessary to remember that the amount of floor space available at upper floor levels decreases. Fig.23 plots the cumulative floor space of six uses on-logarithmic graph paper so that the varying rates of the change in uses can be better analysed. The curves demonstrate that the pattern at different building heights is remarkably similar irrespective of the nature of land use. A 'normal' curve tends to convexity with a 'plateau' reached by the second floor level.

### Summary

A slightly modified Murphy-Vance method of delimitation produces a realistic spatial definition of the commercial core of central Sunderland. A commercial pivot was defined which was considered a meaningful control point from which to analyse the internal structure of the C.A. A clear spatial regularity of land use variation was identified both vertically and horizontally. The main elements of the regularity conform with expected patterns as suggested by theory.

References and end notes

- (1) Davies, D.H., (1960), The hard core of Cape Town's Central Business District: an attempt at delimitation, Economic Geography, Vol. 36, pp. 53-69.
- (2) Carter, H., (1976), 'Urban Geography in Britain, 1945-75', p.67, in Clarke, J.I. and Pinchemel, P., (Eds.), Human Geography in France and Britain. Social Science Research Council.
- (3) These towns include: Nottingham (Vance, J.B.L. (1958), 'The Central Business District of the British city with special reference to Nottingham', (unpublished Ph.D. thesis, Clark University); Derby, Southampton, Norwich, (Mika, P.J.) (1965), A comparative study of some English and American Central Business Districts. Unpublished Ph.D. thesis, Clark University), Edinburgh, (Taylor, W.G., (1967), 'Methods of Central Business District and Central Area delimitation, Vols. 1 and 2, Edinburgh School of Town and Country Planning); Manchester, (Varley, R.A., (1968), 'land use analysis in the city centre with special reference to Manchester'. Unpublished M.A. thesis, Aberystwyth University); Leeds, Bradford, Huddersfield, Wakefield, Harrogate, Halifax, Dewsbury, Castleford, Shipley, (Bateman, M. (1968), 'The nature and processes of urban renewal in the central areas of nine towns of West Yorkshire during the post-war period', Unpublished Ph.D. thesis, Leeds University); Glasgow (Diamond, D.R. (1972), 'The Central Business District of Glasgow', Proceedings of I.G.U. Symposium in Urban Geography, Lund Studies in Geography, (B), pp. 525-534); Coventry, (Khan, M.A. (1972); The growth and morphology of the central area of Coventry, 3 Vols., Unpublished Ph.D. thesis, Birmingham University); and Falkirk, Hamilton, Ayr, Stirling, Kilmarnock, Kirkcaldy, Perth (Levein, C.P.A. (1973), Delimitation and comparative analysis of the central areas of medium sized towns in Central Scotland', Unpublished Ph.D. thesis Edinburgh University). A recent study of Nottingham, Birmingham, Liverpool, Bristol, Cardiff, Cloucester, Huddersfield, Newport, Oldham, Manchester, however, (Thomas, R.W., (1971), 'The comparative analysis of British city central area', Unpublished Ph.D. thesis University of Nottingham) has delimited central areas by scalogram analysis (p.44-51) which it is claimed, has greater "flexibility, and adaptability" (p.51).
- (4) Murphy, R.E., (1971), 'The Central Business District: a study in Urban Geography', p.24.
- (5) Herbert, D.T. (1972), 'Urban Geography', p.87.
- (6) See the 'Report on the Methodology involved in the Field Survey', Town Centre Map, Report No. 2, Planning Dept., Sunderland 1970.
- (7) A similar modification was made by Diamond, D.R., (1962), op.cit., p.525 on the grounds that personal contact was critical in modern credit retailing.
- (8) Ground-floor parks, whether permanent or transitional, were still classified as a 'non-central' use.
- (9) But not the associated depots, storage areas,

- (10) Report on the Census of Distribution and other Services (1964).
- (11) Only three short paragraphs (p.14) are devoted to 'Perception Studies and C.B.D. Delimitation' in R.E. Murphy's book 'The Central Business District'. (Longmans)
- (12) 46.4 hectares.
- (13) 30.2 hectares. Mika, P.J. (1965), 'A comparative study of some English and American Central Business Districts', Unpublished Ph.D. thesis, Clark University, Table 1, p.38.
- (14) Vance, J.B.L., (1958), 'The Central Business District of the British city, with special reference to Nottingham', Unpublished Ph.D. thesis, Clark University, p.212.
- (15) Although shape characteristics of plan elements were computed in a recent study of South Shields, (Openshaw, S., (1973), 'Processes in urban morphology with special reference to South Shields.' Unpublished Ph.D. thesis, Newcastle University.
- (16) For example: (a) 'circle', 'star-like', diamond (Hartman, G.W., (1950), 'The Central Business District: a study in urban geography, Economic Geography, Vol. 26, pp. 237-244). (b) 'quadrate-cross', considered to be the ideal shape for a C.B.D. (Murphy, R.E. and Vance, J.E. (Jnr.) (1954), 'A comparative study of nine Central Business Districts', Economic Geography, Vol. 30, Fig.24). (c) 'trilobate' and 'pin-wheel' the shape of Derby and Norwich's C.B.D.'s, (Mila, P.J., (1965), 'op.cit. p.26.
- (17) For more details see: Blair, D.J. and Biss, T.H. (1967), 'The measurement of shape in Geography: an appraisal of methods and techniques.' Bulletin of Quantitative Data for Geographers, No.11, University of Nottingham. Also see: Bachi, R. (1976), 'Geostatistical analysis of internal migrations', Journal of Regional Science, Vol. 16, No. 1 pp. 1-19.
- (18) In Glasgow, streets made up 32 per cent of the C.B.D. land space (Diamond, D.R., (1962), op.cit. p.524).
- (19) See: Medhurst, D.F. and Parry-Lewis, J., (1969), Urban decay - an analysis and policy, p.7.
- (20) Land values and the growth of the C.A. of Sunderland in the nineteenth century were discussed in Chapter 3. In this section, contemporary land values will be presented as an important parameter of C.A. change. A useful study of the relationships of land values to land use, geomorphology, settlement and other phenomena is given by Gruchy, G.F. de. (1975), 'Some land value relationships in Brisbane's Central Business District', Ekistics, Vol.39, No. 233, April, pp. 268-270.
- (21) Dickinson, G.C. (1963), 'Statistical mapping and the presentation of statistics', p.34-35.
- (22) See, for example: Sargent, C.S., (1972), Towards a dynamic model of urban morphology', Economic Geography, Vol. 48, No. 4, pp. 357-374.
- (23) Calculated from floor space data from the 1970 Town Centre survey.

- (24) Calculated from the field survey of 1975.
- (25) Note: Residential floorspace is not recorded here above 4th floor level. There are three high rise flats which reach 18 levels.
- (26) In the case of retailing: Morris' Department Store (subsequently closed down through fire damage); in the case of 'services': Studios 1 and 2.
- (27) See, for example: Alonso, W. (1960), 'A theory of the urban land market', Papers and Proceedings of the Regional Science Association, Vol. 6, pp. 149-157; Alonso, W., (1964), 'Location and land use', Cambridge, Mass.
- (28) For a schematic representation of the relation of urban land use to building height, see: Carter, H. (1972), 'The study of urban geography', Chapter 9, p. 172.

## Chapter 6

### THE LOCATION OF COMMERCIAL ACTIVITY IN CENTRAL SUNDERLAND, 1966-75,

#### Introduction

So far the spatial dynamics of commercial activity in central Sunderland has been studied from the standpoint of aggregated outcomes of numerous establishments. In this chapter, the behaviour of individual establishments will receive attention. Contemporary patterns are described, underlying processes evaluated and variations in the use of C.A. space by different users identified.

An establishment is defined as any one premise at a given location under the same commercial ownership or management. Thus, within one building, there may be several separate establishments, all being recorded separately. Also, a commercial syndicate owning a chain of stores, for example, may also be recorded as many times as there are outlets. A decision was taken early, therefore, to reject the use of the firm as the basic spatial unit for this analysis on the grounds that a firm is often a legal or economic entity with ill-defined boundaries. One firm may be subdivided, for commercial purposes, into more than one outlet. Strong support for the adoption of 'technical' units with precise spatial limits rather than the 'legal' unit of the firm is given in a variety of sources.<sup>(1)</sup>

Establishments may, therefore, range from single person operators to large concerns employing several hundreds. Furthermore, no two establishments behave in exactly the same in terms of their use of their central area milieu. Because of the relative paucity of literature relevant to the problems examined here,<sup>(2)</sup> the conceptual basis of this chapter is borrowed from other fields of human geography.

#### A conceptual framework <sup>(3)</sup> for studying commercial change

Each commercial establishment in a C.A. seeks different premises according to its space demands, stage in its life, its ability to meet costs and conditions of structure and tenure. Research by the present writer in central Sunderland has revealed that many commercial establishments begin life in adapted properties where rents may be cheaper. Some establishments do not succeed; they die and leave their premises vacant for another user. Others succeed and to accommodate their growth they either expand into adjoining properties or relocate to another site.

The most successful establishments decide to select one site and stay there for a long period.

Commercial change in a C.A., therefore, can be approached in terms of a birth-life-death process,<sup>(4)</sup> in which commercial establishments are classified as (i) births (ii) deaths (iii) stayers and (iv) movers.<sup>(5)</sup> A 'Birth' (or 'entry') occurs when a commercial establishment is located for the first time at a particular address. The birth may be either a completely new outlet with no previous history or it may be an establishment which has moved into the central area from an 'outside' location.<sup>(6)</sup> A 'death' (or 'exit') is likewise recorded when an establishment closes down or moves away to another location outside the defined limits of central Sunderland.<sup>(7)</sup> A 'stayer' refers to an establishment which has remained at the same address for the period of time studied. A 'migrant' (or 'mover') refers to an establishment which has changed its location but remained within the same limits of the C.A.

These four parameters of spatial behaviour of commercial activity are useful in the articulation of particular research problems. Is there for example, a spatial pattern to the 'births', 'deaths', 'stayers', and 'migrants' in central Sunderland? Do turnover rates, i.e. the sum of births and deaths vary in different parts of the C.A.? If so, what processes and factors are significant in shaping the patterns of commercial change in the C.A.? Are there distance and directional biases in recent commercial movements? Does an understanding of central place theory help in explaining the commercial connections between the C.A. and its umland. What influence, if any, does size of establishment have on commercial behaviour.

#### Data sources and operational aspects

The answers to these questions require data on the location, nature and spatial history of individual commercial establishments. No registers exist which comprehensively provided this information. No records are kept by the local planning authority on the spatial behaviour of commercial establishments in central Sunderland unless structural change and/or land use conversion were involved. (These would appear under the Planning Application files which are available for public use).

Reliance was placed on three sources to provide the data required to complete the objectives of this chapter.

(a) National Gazetteer. Sunderland is one of the areas selected for

inclusion in the National Gazetteer Pilot Study. A full background to this scheme is given in Appendix 18. From 1973 onwards, a gazetteer of all land uses, properties and their precise locations was compiled from routine administrative information provided by the Sunderland rating housing and building departments. Regular, ideally monthly updating, of the information was envisaged.

This Gazetteer contains information for individual properties and pieces of land termed Basic Spatial Units (B.S.U.'s). For each B.S.U. the following information can be retrieved: property number, Ordnance map sheet number, land use code, one metre coordinate references, address, and post code.

The first set of data from this source for central Sunderland became available in late 1975 based on 1974 information. It was incorporated and utilised in this chapter because it offered a standardised and regularly monitored supply of information linking land use activity to a particular property. The raw data appears as a print-out.

The geographical value of this locational/land use information is obvious. It permits detailed mapping and, because it is related to rate book and other planning record systems, makes possible micro-correlative analysis. As a source of data for land use analysis, the Gazetteers are still to be exploited. However, random checks revealed certain discrepancies between actual, known land uses and what appeared in gazetteer form.<sup>(8)</sup> It was known that rating, housing and building data, on which the Gazetteer was based, were sometimes suspect. In order to check the Gazetteer, therefore, an independent field survey was carried out in mid-1975.

(b) Independent field survey. This survey involved a personal visit to each separate commercial establishment in the defined area of central Sunderland. A 4" x 3" record card was created for each establishment on which basic information was listed under the following sections:

- (i) postal address of the establishment
- (ii) name of the firm if applicable
- (iii) nature of the activity
- (iv) the vertical extent of the activity in terms of storeys given over to that use
- (v) other information to be added if and when required: eg. rateable values, structural alterations.

Each property or unit would have a least one record card and, frequently, more, depending on the number of separate establishments housed there. One of the problems in the field was establishing an accurate description of the land use activity. The descriptions used in normal valuation lists, although satisfactory for rating purposes, are generally far from unambiguous for detailed geographical analysis. Another practical problem was the difficulty of interpreting present use from outside evidence such as signs and notices. In many instances, internal inspection and enquiry was necessary to establish the nature and organisation of commercial activities. On the larger sites, one other question which had to be determined in the field was whether the activities on that site were functionally independent or inter-dependent. A factory, for example, with office accommodation or storage was recorded as one unit and classified according to its *raison d'entre* which, in this example, would be manufacturing. A flat over a shop, on the other hand, would be recorded as two separate and independent land uses.

A final property of the data was that it should yield some information about the spatial behaviour of the commercial establishments over time in central Sunderland. It was evident in the field survey that changes in the commercial population of the study area were significant and had to be monitored somehow. In the absence of official records, data on commercial change were extracted from telephone directories.

(c) Telephone Directories.<sup>(9)</sup> Telephone directories were employed to provide information on the nature and amount of commercial change in central Sunderland for the 1965-75 period. These sources were comparable for the period, readily available and yielded precise locational information. Exhaustive searches were made through the directories at two-year intervals: 1965, 1967, 1969, 1971, 1973 and 1975. A card was allocated to each separate commercial establishment which appeared in these directories. Each card recorded: (i) the name of the firm, (ii) the nature of its commercial activity (iii) its address. Some establishments were recorded in the earlier directories and unrecorded in later ones. Conversely other commercial establishments did not appear in the directories until recent issues. Accordingly, it was possible to locate and classify those activities which were 'being born' and which were 'dying'. Similarly, by careful and thorough checks, it was possible to establish which commercial activities had moved to another part of the C.A. The origin and the

destination of a commercial activity could be precisely located. Finally, from the directories, it was possible to identify those commercial establishments which have remained on the same site for the duration of the study period.

Two major types of short comings were experienced in this section of the work. Firstly, factual errors of detail and incorrect updating of information were occasionally identified. A telephone directory is not a definitive document and should not be accepted uncritically as a source of information for geographical enquiry. Secondly, and more seriously, a telephone directory does not contain details of all the commercial activity in an area. In this particular study, several commercial outlets, which were known to exist, were unrecorded in the directories. Most frequent of these establishments were branch firms of retail organisations which, through a deliberate internal policy, were not connected to the public telephone system.

Both these shortcomings were satisfactorily resolved by a laborious series of further checks: numerous telephone calls were made to establish particular facts which could not be deduced from the directories; and visits were also carried out in some cases. The personal knowledge of the study area by the writer over this ten years study period proved helpful in determining the exact details of particular establishments.

The exercise of compiling a carded record of all the commercial activity in central Sunderland since 1965 took two full months in the summer of 1975. The results are portrayed and interpreted in the following sections as evidence of the birth - life - death process.

In the following analysis, commercial establishments were placed into four broad categories: (i) "retailing"(ii) offices (iii) service trades (iv) industrial. Retailing includes all activities which are dominantly concerned with selling articles to a public consumer. Under this heading comes grocers, food retailers, confectioners, stationers and newsagents, clothing and footwear, household goods shops, general stores and non-food retailers, such as jewellers, unless manufacturing and repairing are important productive activities.

'Offices' covers a wide range of tertiary activities including financial, professional, commercial and ancillary executive-managerial-professional establishments. Local government departments such as social services, education and water were excluded and, located under Services.

'Services' consists of catering, repairs, advisory activities such as travel agencies and other ancillary uses such as hairdresser, photographer, etc., recreation, religions and cultural uses and health.

Fig. 24. Commercial 'births' in central Sunderland 1966-1975.

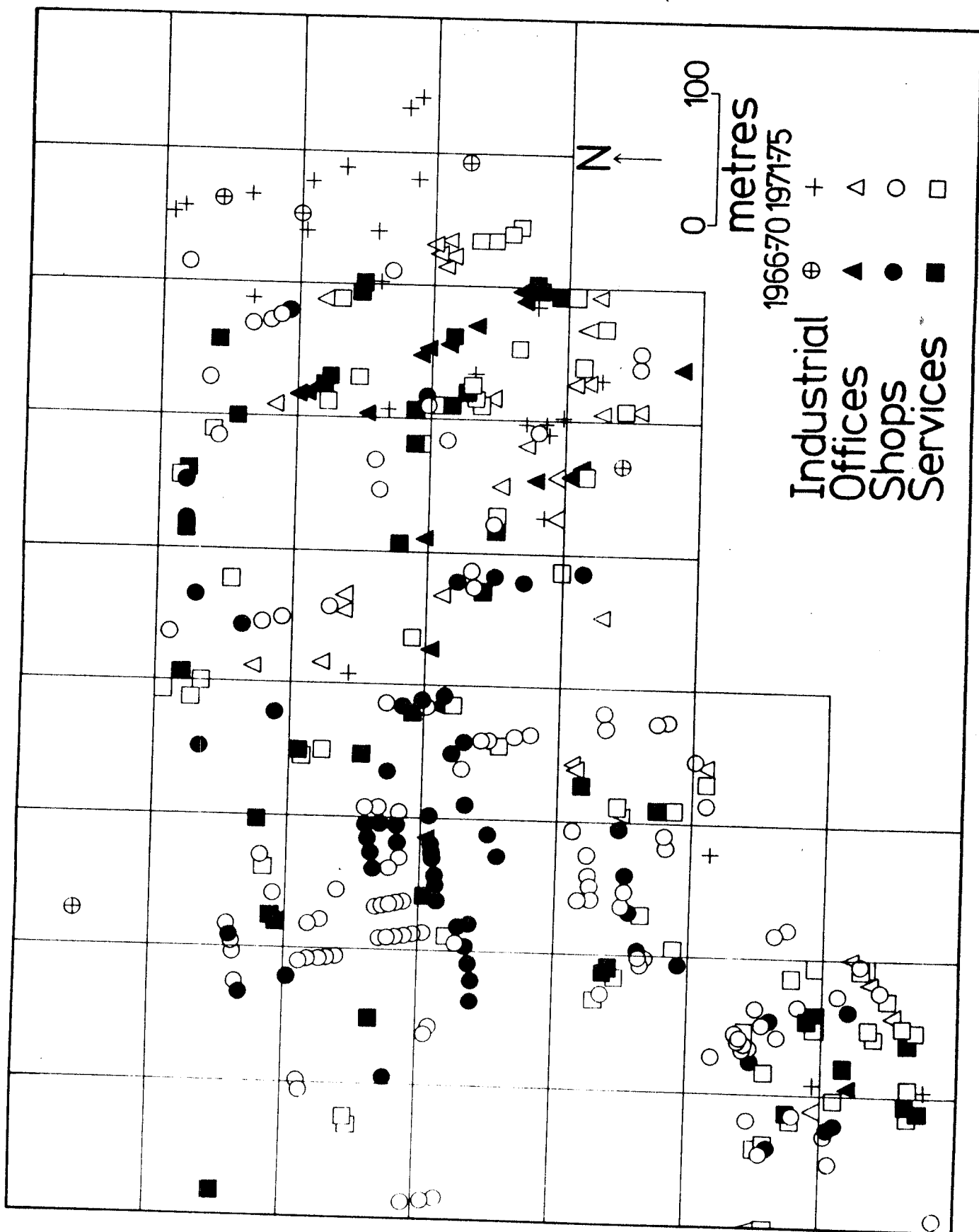

'Industrial' covers all manufacturing activity, warehousing, printing and repair work, and storage.

Most establishments fell neatly into one of these groups but a significant minority possessed properties which necessitated careful consideration and choice. The decision to allocate an establishment into one or the other category was based on its dominant activity. In the absence of readily available data on sales turnover, number of employees and other quantitative measures, the allocation was made on the basis of the personal knowledge of the writer and a field check. A fuller classification of commercial establishments is provided in Appendix based on a standard system. (10)

### Evidence of the birth-death-life concept

From these data sources more than 1000 separate commercial establishments were included in the analysis covering 1966 to 1975. For organisation ease, the different types of establishments are discussed separately in terms of numbers, distribution and nature of activity.

#### (i) Births

The distribution of 'births' of commercial establishments is mapped in Fig. 24. In addition to the four functional categories the data were grouped into two time periods. A cell by cell analysis is provided in Table 16. There were 351 'births' in central Sunderland between 1966 and 1975. 164 or nearly 47 per cent of these were retail establishments, 102 (29 per cent) were 'services', 56 (16 per cent) were 'offices' and only 29 (8.3 per cent) were 'industrial'. The ten year period was divided into two halves, the first from the beginning of 1966 to the end of 1970, and the second from the beginning of 1971 to the end of 1975. It is apparent from Table 16 that the number of new commercial establishments in 1971 - 1975 was almost double those in 1966 - 1970. Much of this can be attributed to the completion of the new town centre in 1970 and its occupation by new activity. During 1975 and 1976 the frequency of commercial births has returned to the more 'normal' rate achieved in the mid 1960's.

The distribution of births can be analysed in terms of (i) their location and (ii) their structure. Locationally, the new commercial activity has arranged itself in a random manner, but with several discrete clusters emerging. One such cluster occurs in cells, 1, 2, 4 and 5, covering the Vine Place, Derwent and Olive Streets area, (11)

Table 16: Analysis of commercial 'births' in central Sunderland 1966-75

Cell No.	R	O	S	I	R	O	S	I	R	O	S	I	Totals
1	2	0	2	0	2	1	2	0	4	1	4	0	9
2	1	1	2	0	3	2	8	2	4	3	10	2	19
3	0	0	0	0	1	1	0	0	1	1	0	0	2
4	1	1	1	0	3	1	3	0	4	2	4	0	10
5	2	0	2	1	11	0	4	0	13	0	6	1	20
6	0	0	0	0	2	0	0	1	2	0	0	1	3
7	0	0	0	0	2	1	1	0	2	1	1	0	4
8	0	0	0	0	0	0	0	0	0	0	0	0	0
9	1	0	2	0	4	0	2	0	5	0	4	0	9
10	4	0	0	0	10	0	4	0	14	0	4	0	18
11	0	0	2	0	4	3	2	0	4	3	4	0	11
12	1	0	0	0	0	1	1	0	1	1	1	0	3
13	0	2	0	1	0	1	1	0	0	3	1	1	5
14	0	1	0	0	2	6	3	2	2	7	3	2	14
15	0	0	0	0	2	0	0	0	2	0	0	0	2
16	3	0	0	0	2	0	0	0	5	0	0	0	5
17	12	1	1	0	3	0	1	0	15	1	2	0	18
18	5	1	0	0	6	0	2	0	11	1	2	0	14
19	3	1	1	0	2	1	1	0	5	2	2	0	9
20	0	2	1	0	3	3	3	3	3	5	4	3	15
21	0	5	6	0	0	1	6	2	0	6	12	2	20
22	0	0	0	1	0	5	4	0	0	5	4	1	10
23	0	0	0	0	0	0	0	0	0	0	0	0	0
24	0	0	0	0	2	2	0	0	2	2	0	0	4
25	2	0	1	0	6	0	0	0	8	0	1	0	9
26	7	0	1	0	14	0	0	0	21	0	1	0	22
27	3	0	3	0	4	0	2	0	7	0	5	0	12
28	0	0	0	0	1	3	1	1	1	3	1	1	6
29	0	1	2	0	2	0	0	0	2	1	2	0	5
30	1	2	5	0	1	3	3	2	2	5	8	2	17
31	0	0	0	0	1	0	0	6	1	0	0	6	7
32	0	0	0	0	0	0	0	0	0	0	0	2	2
33	0	0	1	0	0	0	0	0	0	0	1	0	1

Table 16. continued

Cell No.	R	O	S	I	R	O	S	I	R	O	S	I	Totals
34	1	0	0	0	2	0	0	0	3	0	0	0	3
35	1	0	3	0	4	0	1	0	5	0	4	0	9
36	2	1	1	0	0	0	3	0	2	1	4	0	7
37	2	0	0	0	3	1	1	0	5	1	1	0	7
38	2	0	3	0	0	0	2	0	2	0	5	0	7
39	1	0	1	0	4	1	0	1	5	1	1	1	8
40	0	0	0	1	1	0	0	3	1	0	0	4	5
41	0	0	0	0	0	0	0	0	0	0	0	0	0
42	0	0	0	0	0	0	0	0	0	0	0	0	0
43	0	0	0	0	0	0	0	0	0	0	0	0	0
44	0	0	0	1	0	0	0	0	0	0	0	0	0
45	0	0	0	0	0	0	0	0	0	0	0	0	0
46	0	0	0	0	0	0	0	0	0	0	0	0	0
47	0	0	0	0	0	0	0	0	0	0	0	0	0
48	0	0	0	0	0	0	0	0	0	0	0	0	0
49	0	0	0	0	0	0	0	0	0	0	0	0	0
50	0	0	0	0	0	0	0	0	0	0	0	0	0
Total	57	19	41	5	107	37	61	23	64	56	102	29	351

cells 12,19,28 and 37, tended in the 1971 - 1975 period to attract new office establishments. These and other births have been attracted to the high class properties vacated by shops and other functions moving into the new shopping precinct. The Fawcett Street area, whilst still the centre of banking and finance in central Sunderland has relinquished its leadership of retailing to the new centre. The 'anchor' effects of Binn's, Woolworths and Joblings, three departmental stores in Fawcett Street and John Street have crucial roles in attracting and retaining new retail - office and - service activity in these streets.

The density of births increases again in cells, 14,21,30 and 39 where north-south aligned streets house a different mixture of commercial activity. Retailing is of minor importance compared to office and services and even industry. But significant differences of mix can be observed. In Frederick Street, for example, there is more commercial diversity than any other street in central Sunderland: all four major uses are well represented with a large number of sub-types of each. This can be attributed to the streets particular locational properties being sufficiently close to the office quarter to the west, in contact with shopping areas at its north and south ends, offering suitable accommodation for a wide range of miscellaneous services and, at the same time, able to appeal to small light industrial businesses. Norfolk Street, is similar to Frederick Street in that its new commercial activity between 1966 and 1975 also covers a wide range of uses. However, its more peripheral location within the C.A. has reduced the diversity. Foyle Street, a shorter and less busy street has attracted significantly higher numbers of industrial establishments which do not suffer from a lower pedestrian activity. West Sunnyside stands out rather differently as a street with a high status for office accommodation. Accordingly, the births here, since 1966, are dominated by office establishments, many of which share accommodation with other similar activities.

Further east, Nile Street and Villiers Street fall outside the C.A. of Sunderland as delimited in Chapter 5. This conclusion is confirmed by the activity use of the two streets. Fig.24 shows that cells 31,32 and 40 have received some new commercial activity but it is only of an industrial nature. And, unlike the industrial activity found in Foyle Street, it is of a heavier and less intensive nature, such as car repair shops, furniture and cabinet makers.

The absence of new commercial activity in the cells on the north and eastern edges of Fig.24 reflect the demolition of some old property; the conversion of others into warehouses and the creation of car-parks and cleared sites.

The high frequency of births in this area reflects two important characteristics: firstly, its peripheral position within the C.A. of Sunderland and its structural qualities, have resulted in relatively low - average rateable values. Secondly, the area adjoins the Park Lane bus-station, as well as containing a number of street bus stops and acting as a major entrance and exit through which vehicular and pedestrian traffic are funnelled into and out of the C.A. Its business potential, therefore, is high, a fact which is reflected in the existence of two branch banks in Vine Place and the corner of Derwent Street. Most of the new 'births' in commercial activity in this part of central Sunderland falls into the retail and service categories with offices and industrial uses, especially, being poorly represented. The invasion of shops and service establishments into Derwent and Olive Streets, a post-war phenomenon, is now virtually complete; only one property remains totally residential at the time of writing.

A second separate cluster of new commercial activity is located in cells 10 and 11 where Blandford Street and Holmside have attracted a similar mixture of retailing and services to Derwent and Olive Streets, but of a higher quality. The higher quality reflects the longer tradition of commercial activity in cells 10 and 11, their more central location and values are proportionally higher. The barriers presented by Brougham Street and the railway to the north, and Crowtree Road and Holmside to the east and south, respectively, help to define this cluster. The physical isolation of this area from other streets has both positive and negative effects on commercial activity. On the one hand, it has encouraged a distinctive <sup>(12)</sup> and flourishing commercial environment; on the other hand, it has reduced the customer density.

The largest cluster of births, however, occurs in cells 17 and 27 which cover most of Walworth Way and Market Square in the planned shopping precinct. Here, retailing reaches its greatest dominance attracted by accessibility, proximity to parking and public transport terminals, and concentration of pedestrian activity. The micro-locational advantages of Market Square compared to the less favoured Walworth Way can be seen in the fact that most of the births of commercial establishments occupied units in the former whilst Walworth Way was not 'filled' with new activity until after 1971.

High Street West, Fawcett Street and even John Street are zones of comparatively low rates of new activity. Fawcett Street, aligned through

What conclusions, then, can be reasonably made with respect to the births of commercial establishment in central Sunderland since 1966? The analysis and data presented above suggest that the activity was influenced by forces. New commercial establishments reveal three sets of patterns: (a) spatial (b) temporal (c) structure. The preference of new establishments for some parts of the commercial space of central Sunderland has been observed and preferences change through time. The centroid of 'births' is moving west all the time: in 1966-70 the centre of all 'births' was in cell 19, and in 1971-75 it had moved into cell 19. in keeping with the natural trends of central Sunderland. Some functional zonation is recognisable with retailing activity concentrating in the western cells, offices in central cells, industrial in eastern cells and services dispersed fairly widely over all. Within each activity category, some types of establishments are more likely to be born than others. Clothes and fashion shops, house furnishing stores, and grocery stores in that order, for example, were most frequent 'births' in retailing. In office activity, building societies and insurance agents were the most frequent 'births'. In services, miscellaneous activities, restaurants and cafes and hair-dressers were the most frequent types; and in industry, car repair shops. It is interesting to note that the structural patterns of 'birth' activity in central Sunderland possesses broad similarities with the Hyde-Park-Kenwood area of Chicago. Finally, the two-year interval used in the analysis suggests that there is also a temporal pattern to the births. It is clear that the rate of change, which peaked in 1970, is now (mid-1976) continuing to decline. Between January and the end of May, 1976, only 8 'births' were recorded in central Sunderland. In 1975, 28 were recorded. Of course, the 1966-75 interval can be considered an exceptional period with the construction of the new shopping centre and the implications it had on commercial activity in central Sunderland. Over the ten years analysed, 1976-71 emerges as a two year period in which there was a distinct 'burst' of new commercial activity.

In order to throw more light on the total changes of commercial activity it is necessary to examine the patterns of 'deaths'.

#### (ii) Deaths

A death occurs when a commercial establishment vacates a property either by relocation to another premise outside the defined limits of the study area or through liquidation. In the case of central Sunderland, deaths through liquidation were by far the most important numerically. The commercial history of the area since 1966 was such that 'deaths' occurred more frequently than 'births'. The following analysis is

Fig. 25. Commercial 'deaths' in central Sunderland.

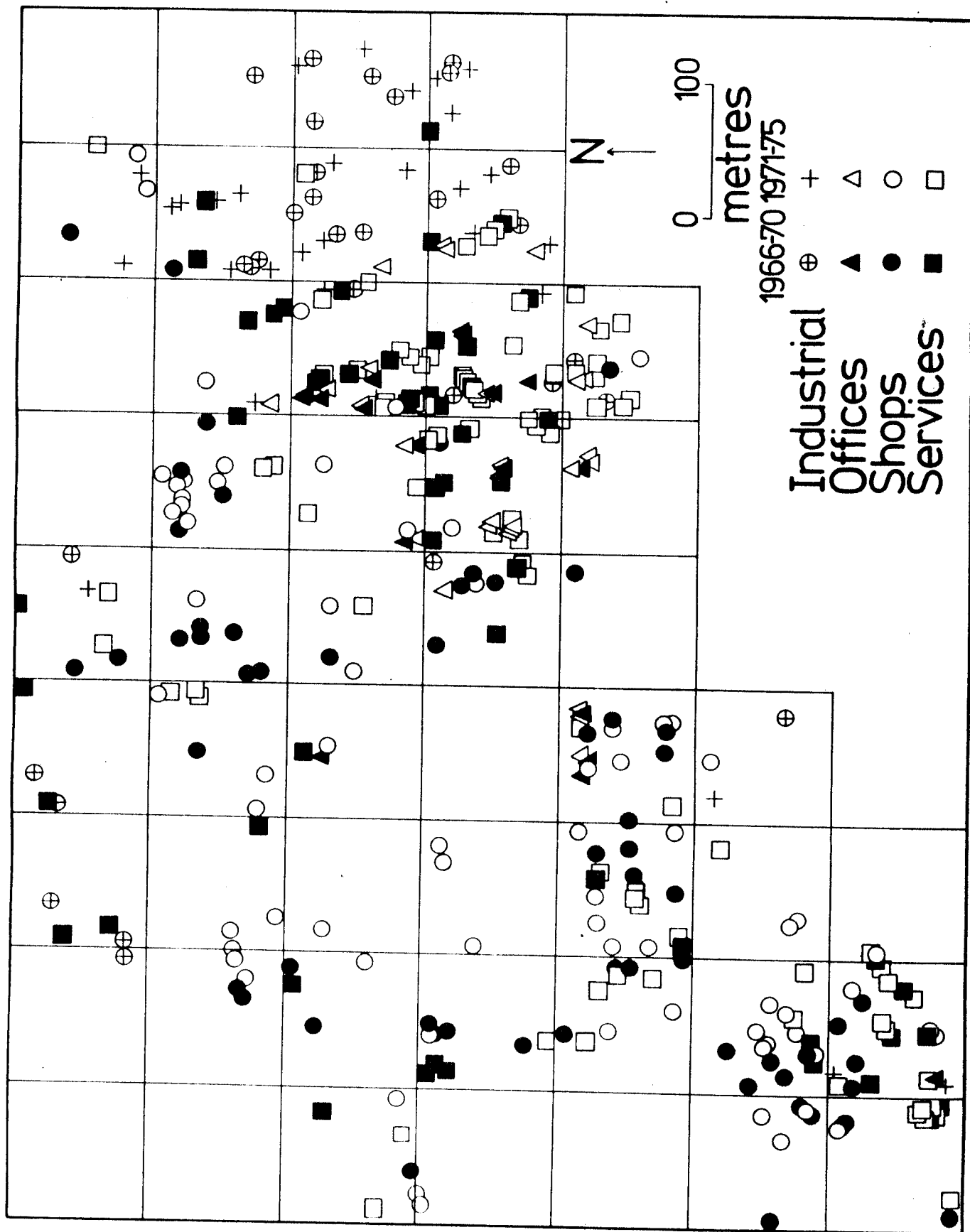

Analysis of the distribution of 'deaths' yields points of similarity and dissimilarity with that of 'births'. Clusters of 'deaths' occur in the Vine Place - Derwent - Olive Streets and the Blandford - Holmside area as before. Cell 2, for example, covers the Derwent - Olive Street area, the physical and functional characteristics of which were noted in the previous section. Over half of the 'deaths' here consisted of service establishments mainly of the miscellaneous type which are small in size and transient in character. Cell 5, on the other hand, contains fewer 'deaths' of which three quarters are retail establishments. The commercial difference can be accounted for by the fact that both Olive and Derwent Streets are one-way streets leading out of central Sunderland, whilst Vine Place is a one way street leading into central Sunderland.

The virtual absence of commercial 'deaths' in cells 17,17,26 and 27 indicates the success of establishments located in the planned town centre. Not surprisingly, the 'deaths' which did occur were all retail establishments.

The scale and nature of commercial 'deaths' in the eastern half of central Sunderland, however, was in marked contrast: Fig. 25 demonstrates clearly the greater incidence of deaths in cells 20,21 and 30 in particular, and in cells 22,31, 38 and 40, to a lesser degree. The high density of 'deaths' in these cells can be attributed to the more peripheral location within the C.A., the physical structure of properties, the functional specialisation of the streets and rental and rateable values. Over 60 per cent of all the deaths in cells 20 and 21 are classed as 'services' compared to the average of 37.8 per cent for the whole of the study area. Offices are the second most likely type of establishment in these cells to die. Retailing shares the third and fourth rank with industrial uses: the former use not being suited to this area because of low pedestrian activity, the latter because of restrictive planning measures,<sup>(14)</sup> and inability to compete with other higher order uses. 'Deaths' of industrial establishments were concentrated in the most easterly of the cells shown in Fig.24.

The demolition of properties in Bridge Street, Green and Cumberland Streets and others in the north is reflected in the occurrence of commercial 'deaths' recorded for cells 42 to 50. The same applies along Crowtree Road (cells 9 and 16) where compulsory purchase orders forced the closure of small businesses.

The detailed record of commercial 'deaths' in the C.A. between 1966 and 1975 is given in Table 17. Of the 384 'deaths' listed, 37.8 per cent were 'service' establishments, 34.9 per cent retail establishments, 15.6 per cent industrial and 11.7 per cent offices. By comparison with Table 16 it is possible to derive an indication of the increasing importance of



Table 17. Continued

Cell No.	<u>1966-70</u>				<u>1971-75</u>				<u>1966-75</u>				Totals
	R	O	S	I	R	O	S	I	R	O	S	I	
34	2	0	0	0	2	0	0	0	4	0	0	0	4
35	0	0	1	0	3	0	0	0	3	0	1	0	4
36	1	0	0	0	3	0	3	0	4	0	3	0	7
37	6	0	0	0	1	0	0	0	7	0	0	0	7
38	4	0	1	0	9	0	2	0	13	0	3	0	16
39	0	0	3	0	1	1	0	1	1	1	3	1	6
40	1	0	2	3	0	0	0	5	1	0	2	8	11
41	0	0	0	0	0	0	0	0	0	0	0	0	0
42	0	0	0	0	0	0	0	0	0	0	0	0	0
43	0	0	0	1	0	0	0	0	0	0	0	1	1
44	0	0	2	2	0	0	0	0	0	0	2	2	4
45	0	0	2	2	0	0	0	0	0	0	2	2	4
46	2	0	1	1	0	0	2	1	2	0	3	2	7
47	0	0	0	0	0	0	0	0	0	0	0	0	0
48	0	0	0	0	0	0	0	0	0	0	0	0	0
49	1	0	0	0	2	0	1	2	3	0	1	2	6
50	0	0	0	0	0	0	0	0	0	0	0	0	0
Total	62	19	49	26	72	26	96	34	34	45	145	60	384

retailing and office uses compared to miscellaneous services and industrial uses. Furthermore, it is clear that the rate of 'deaths' did not increase substantially, with the exception of service establishments, in the 1971-75 period compared to the 1966-70 period. Again, like births, some establishments are more likely to die than others. Of the office category, insurance agents and financial advisers/consultants had the greatest mortality probability. From retailing, three types of shops head the mortality table: food shops, furniture/carpet stores and fashion shops. In the service category, agencies, miscellaneous service offices, and hairdressers were the most frequent 'deaths'.

### (iii) Migrants

Commercial establishments, like individuals, relocate for a variety of reasons. Information is accumulated and impressions gained by firms which may then be utilised in the decision making process. Here, distance and directional attributes of moves are measured to reveal the spatial dimension of this process.

Of the 165 commercial establishments relocating in central Sunderland since 1966, 40.6 involved retail establishments, 27.9 per cent were office establishments, 25.5 per cent service establishments and only 6 per cent were classed as industrial.

To identify length and orientations of 'movers', the origin and destination of each mover was mapped and connected by a straight line. The straight line distance of the migration was measured and the compass orientation of destination from the origin of each mover was read. Fig. 26 maps the pattern of retail migrations. Four cells stand out for the amount of retailing they attract. These are cells 17, 18, 26 and 27 and constitute the new shopping centre. Other cells including cells 2, 5, 6, 11 and 12 are also important attracters of retailing. Significantly, this latter group of cells is located to the south and south west of the first group. Cells to the north and east, viz: 28, 29, 36, 37 and 38, on the other hand, experienced a net outflow of retail establishments. The only cells on the west side of central Sunderland to lose retail establishments are cells 9 and 16. Here the demolition by compulsory purchase of small businesses along Crowtree Road for the new multi-Recreational Centre was the main cause.

The focus of the migratory pattern of office establishments is east of the core and more confined areally than that for retail activity. The functional sub-regions of central Sunderland as defined by migratory flows is most clearly expressed in Fig. 27. With the exception of the south west

Fig. 26. Migration of retail establishments, 1966-75.

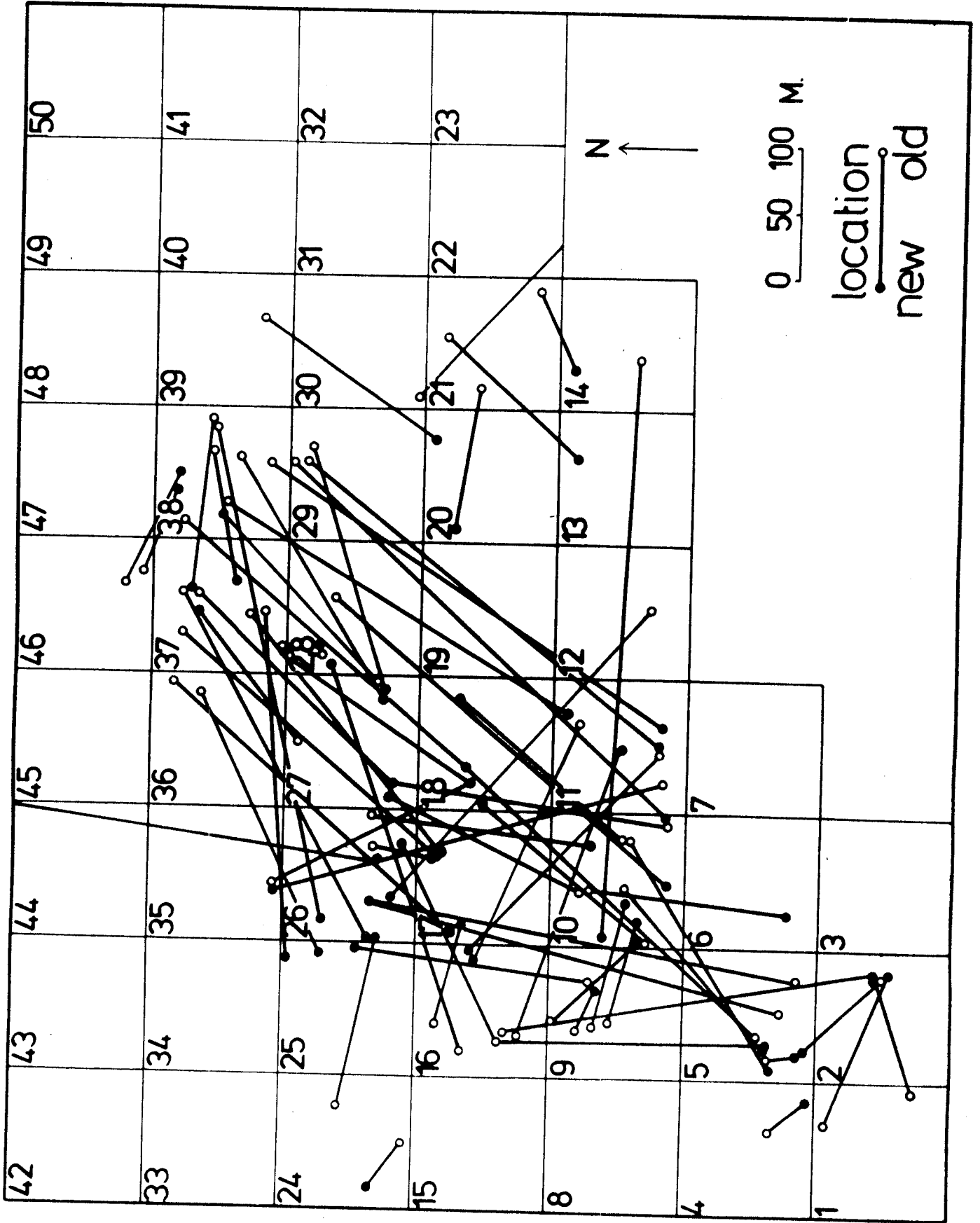

Fig. 27. Migration of office establishments, 1966-75.

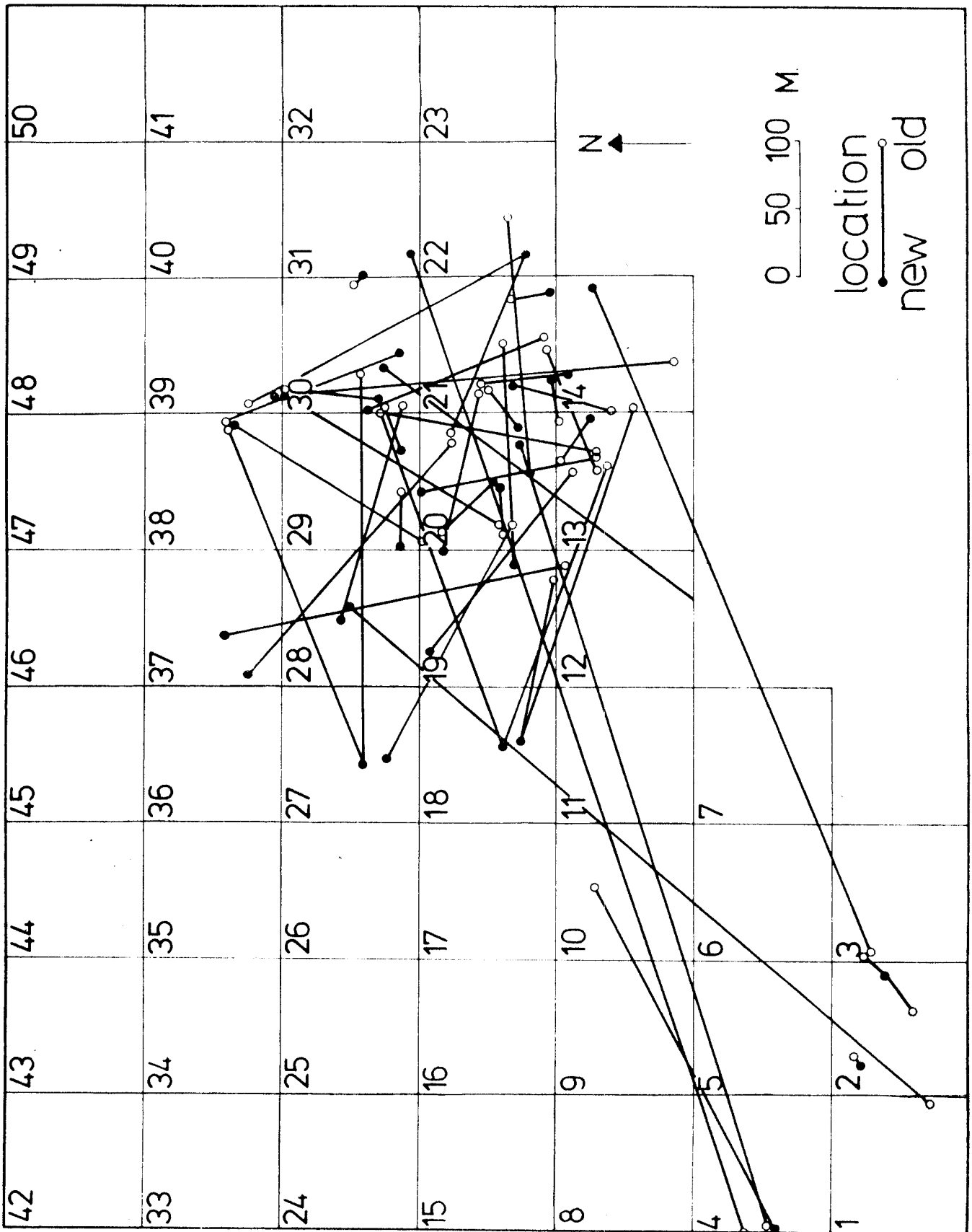
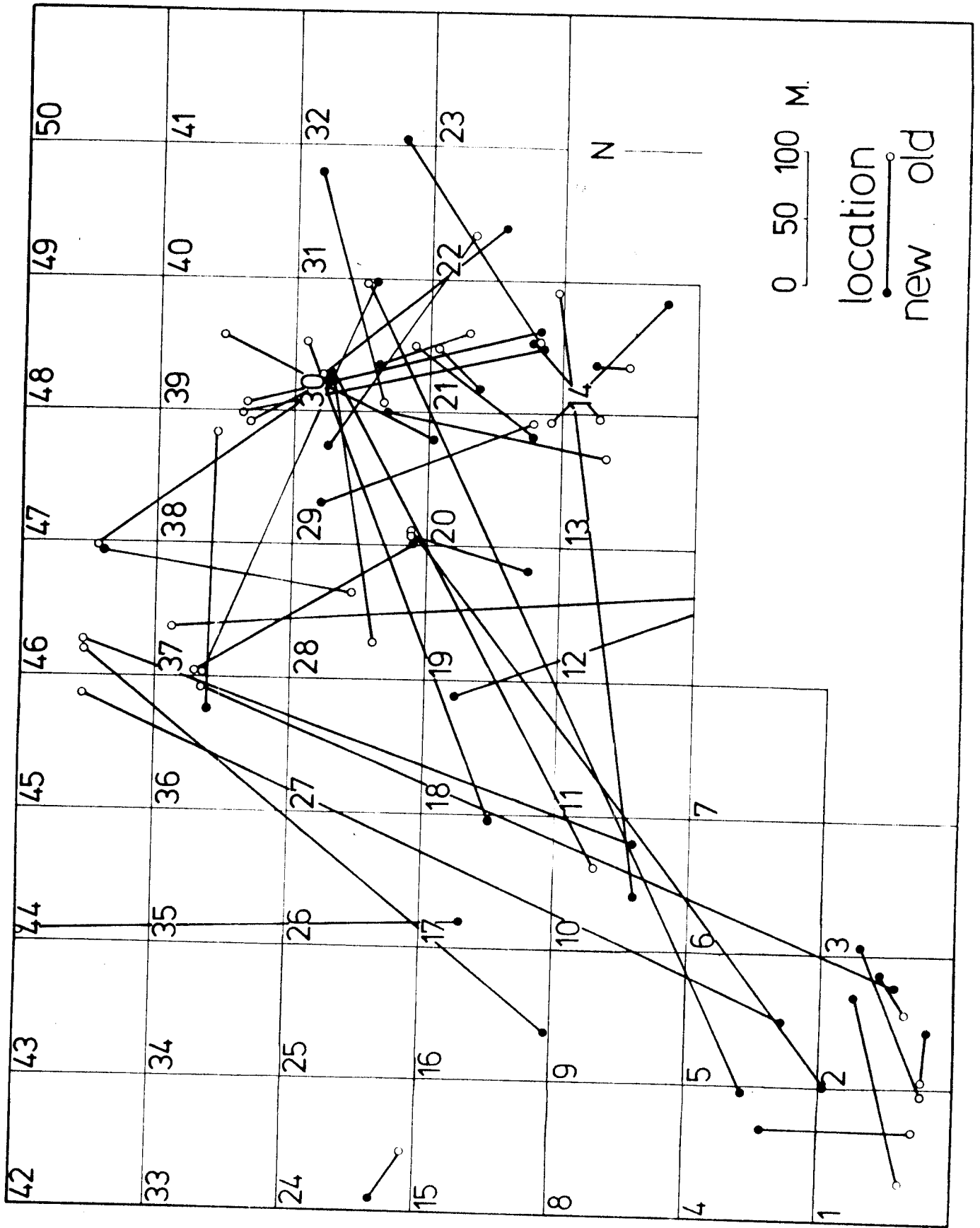

Fig. 28. Migration of service establishments, 1966-75.



corner, which generated a minor flow of office establishments, the nucleus of office changes involved a contiguous block of cells including Number 28,29,30,19,20,21,13 and 14. The east to west migration was not as evident with offices as with retail establishments. However, there was some invasion of office functions into Fawcett Street and Market Square, (cells 18 and 27, for example).

Service activities had a slightly higher propensity to move in the C.A. between 1966 and 1975 than office activities. Also, the spatial pattern of these migrations is more diffuse than those involving office establishments (see Fig.28). If a core of service shifts can be identified, it lies in the Frederick Street to Norfolk Street area (cells 29,30,31,20 and 21).

Finally, industrial establishments were also prone to move to new destination in response to various geographical, economic and other forces. Due to the numerical insignificance of industrial migrations in the C.A. since 1966, however, the results are not portrayed and graphed like the others. It is sufficient to state that the migratory field of industrial establishments is firmly weighted to the streets in the extreme east of the survey area and in particular cell number 30,31,22,33 and 41.

The composition of migrating commercial establishments was found to be very similar functionally to that of 'births' and 'deaths'. Insurance brokers, financiers and building societies were the most likely to move from the office category. Cloth shops, house furnishing stores and jewellers were the most likely to move in the retail sector. In the service groups, agencies, rental and miscellaneous services were the most frequent type of establishment that moved their business premises. Industrial migrations were dominated by the builder/plumber/electrician category, many of whom were single or very small operators.

The analysis of two components of the migration process (length of move and orientation) is valuable in identifying further aspects of the spatial dynamics of C.A. change.<sup>(15)</sup>

The mean distance of migrations by all commercial establishments between 1966 and 1975 was 220metres. 'Offices' moved, on average, less than retail establishments (182 metres :186 metres); 'services' moved less than industrial establishments (237 metres:279 metres). Each category, with the exception of 'industrial', was more likely to migrate 100 - 200 metres than 1 - 100 metres. This observation suggests that there is a threshold distance under which the costs of migration weigh more heavily against the advantages of a new location. The migratory behaviour of retail, office and service establishments in terms of distance is graphed

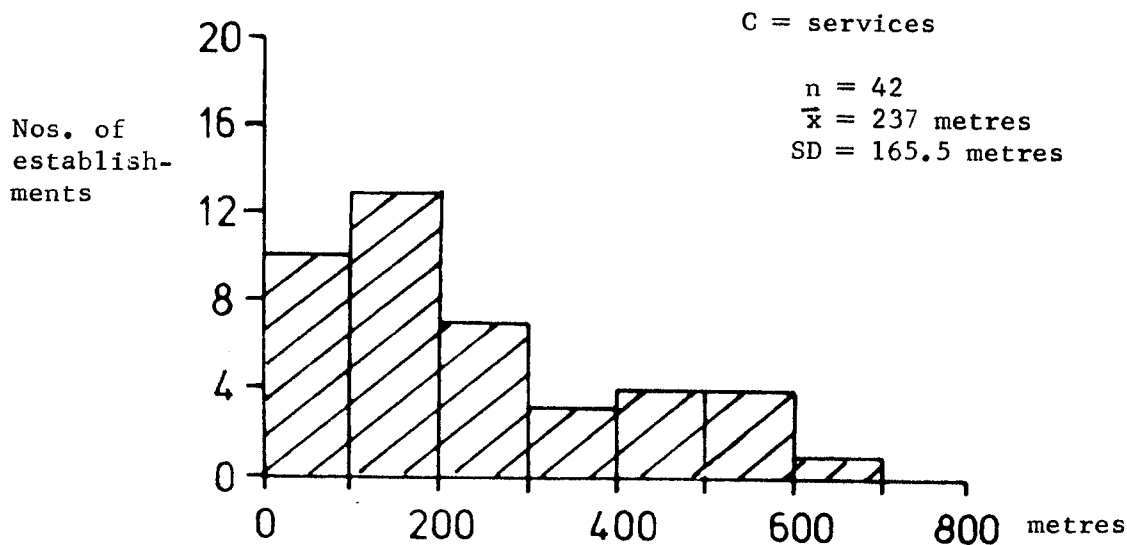
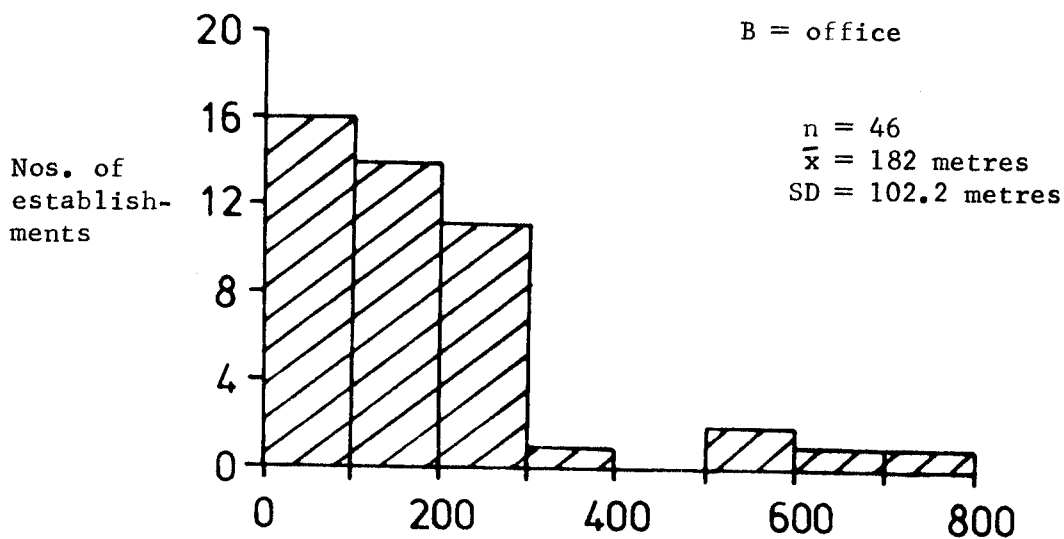
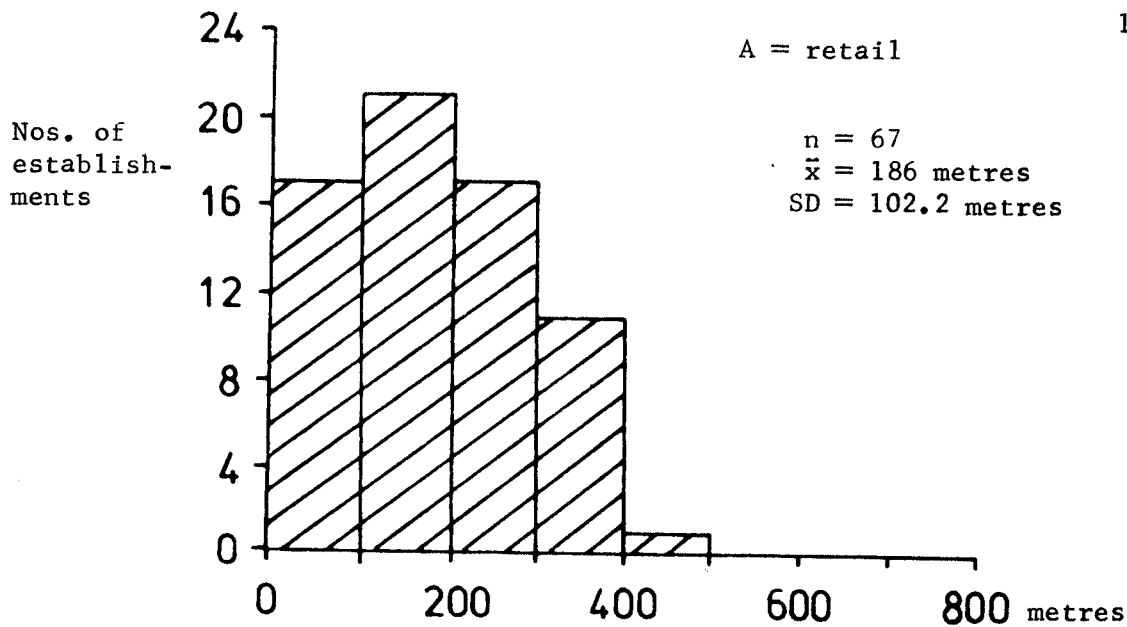
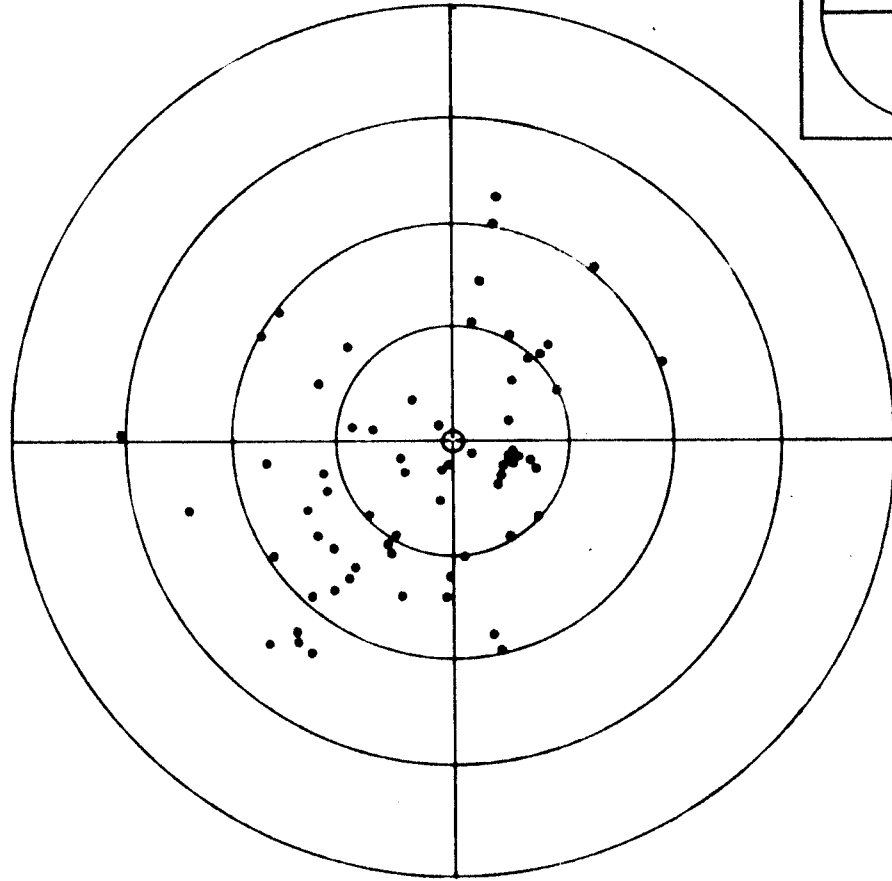
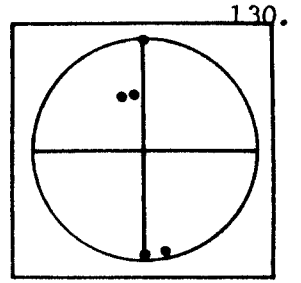

Fig. 29. Distance migrated by commercial establishments.

# A. Retailing



# B. Offices

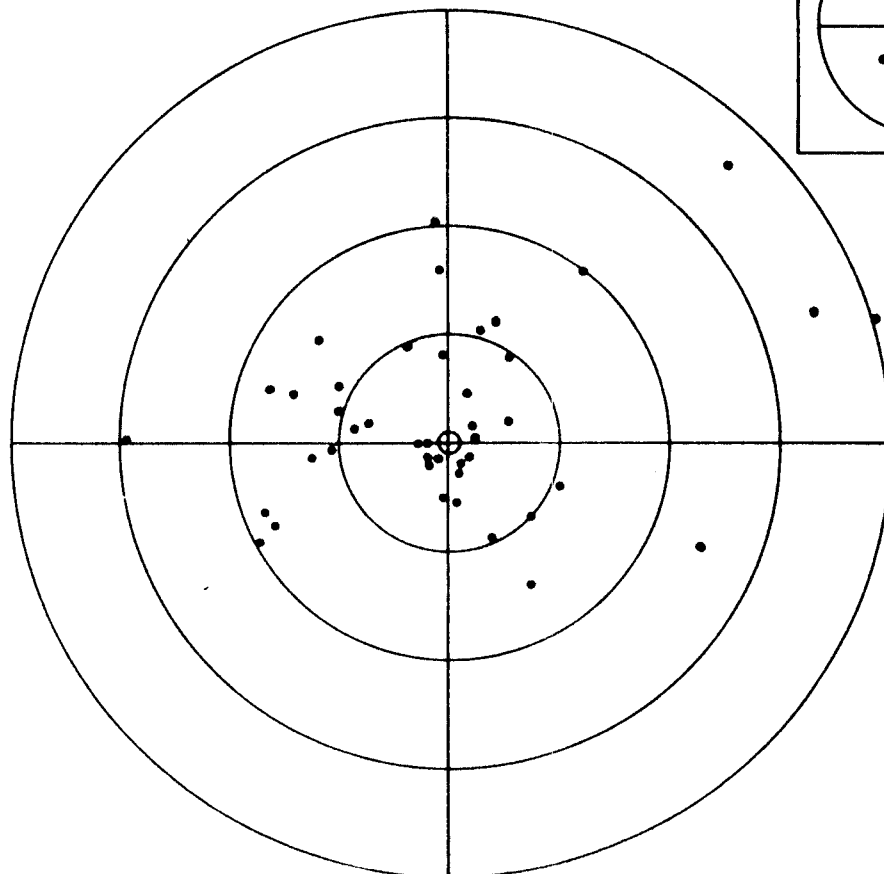
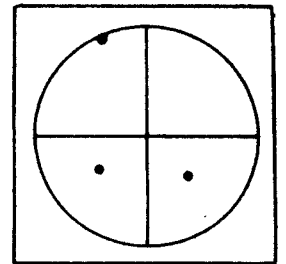
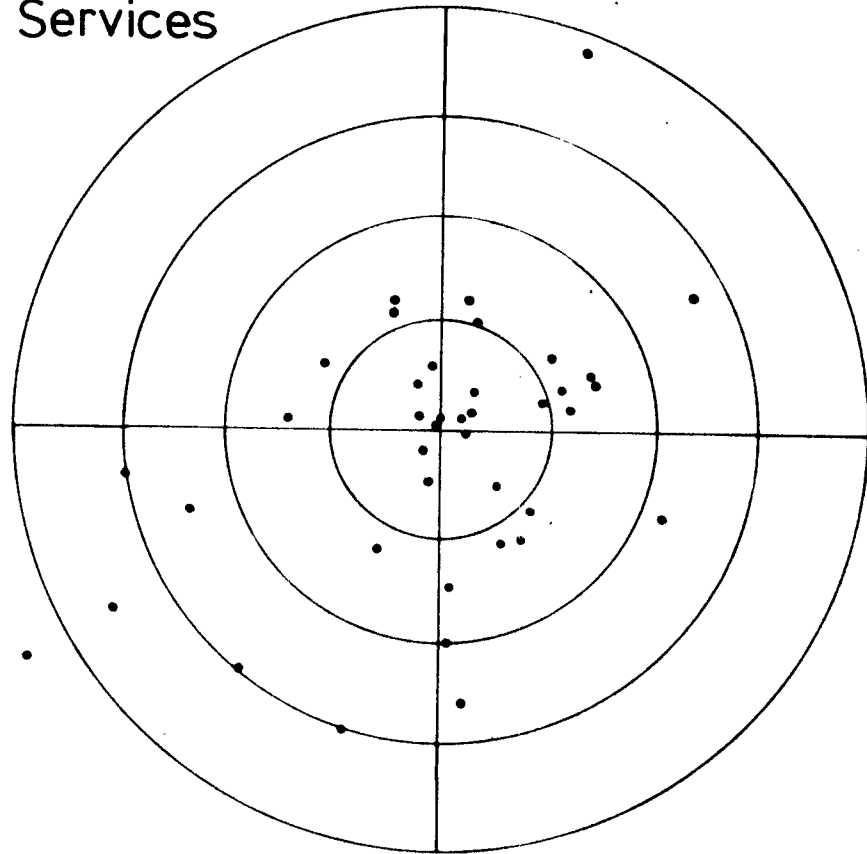

Fig. 30. Directional bias in migration of establishments.

C. Services



Key

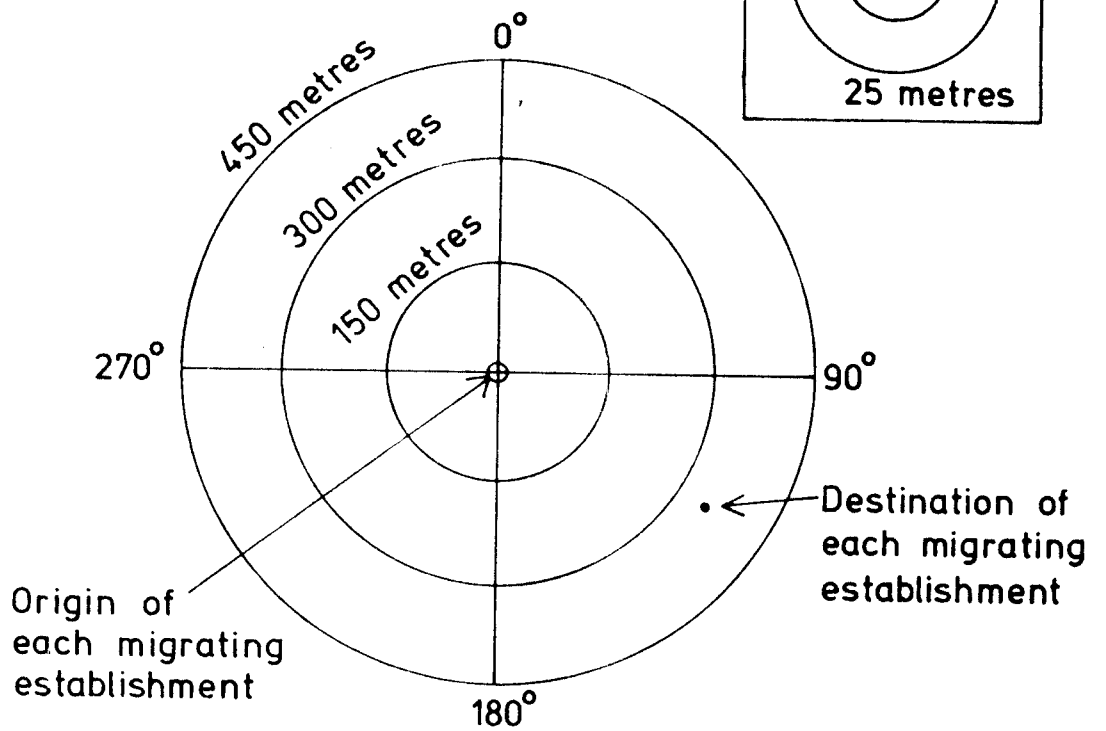

Fig. 30. (Continued) Directional bias in migration of establishments.

in Fig. 29. It can be seen that office and service establishments did, on occasions, migrate from one end of the C.A. to the other, whilst 'retail' moves were confined to less than 500 metres.

The other parameter of commercial migration analysed is directional bias. A circular graph is used to display the directional and distance components. The centres of this diagram represents the origin of each migrating establishment. The points represent the destination of these establishments plotted according to the distance moved and the orientation from the origin. (Fig.30).

Retailing (A) has a strong directional bias with 35 per cent of all moves orientated towards the south west quadrant. This result reflects the general migratory trends of the C.A. in the direction of residential areas outlined in Chapter 3.

Migrations of office and service establishments, on the other hand, have no firm directional biases. Nor is there any apparent correlations between length of move and directional bias which Adams (p.321) found in his research on residential moves. Considerable further analysis is necessary before firmer interpretations can be offered; furthermore, the behavioural investigation in Chapter 7 will throw more light on the spatial analysis offered here.

#### (iv) Stayers

The fourth category of commercial establishments to be considered is that made up of outlets which have remained in the same premises for the full period studied. These are called 'stayers'.

The distribution of the 'stayers' in central Sunderland since 1966 shown in Fig.31, Table 18 gives a summary of their composition. Of the 383 'stayers', 133 (34.7 per cent) are retail establishments. Clothes/fashion shops, furniture stores and shoe shops are the most stable types of shops. Office establishments which have not migrated make up 20.9 per cent of the total, and services (28.7 per cent) and industrial (15.7 per cent). Of the offices category, banks and solicitors were the most stable, whilst restaurants/public houses and entertainment establishments enjoyed the greatest stability in the service category.

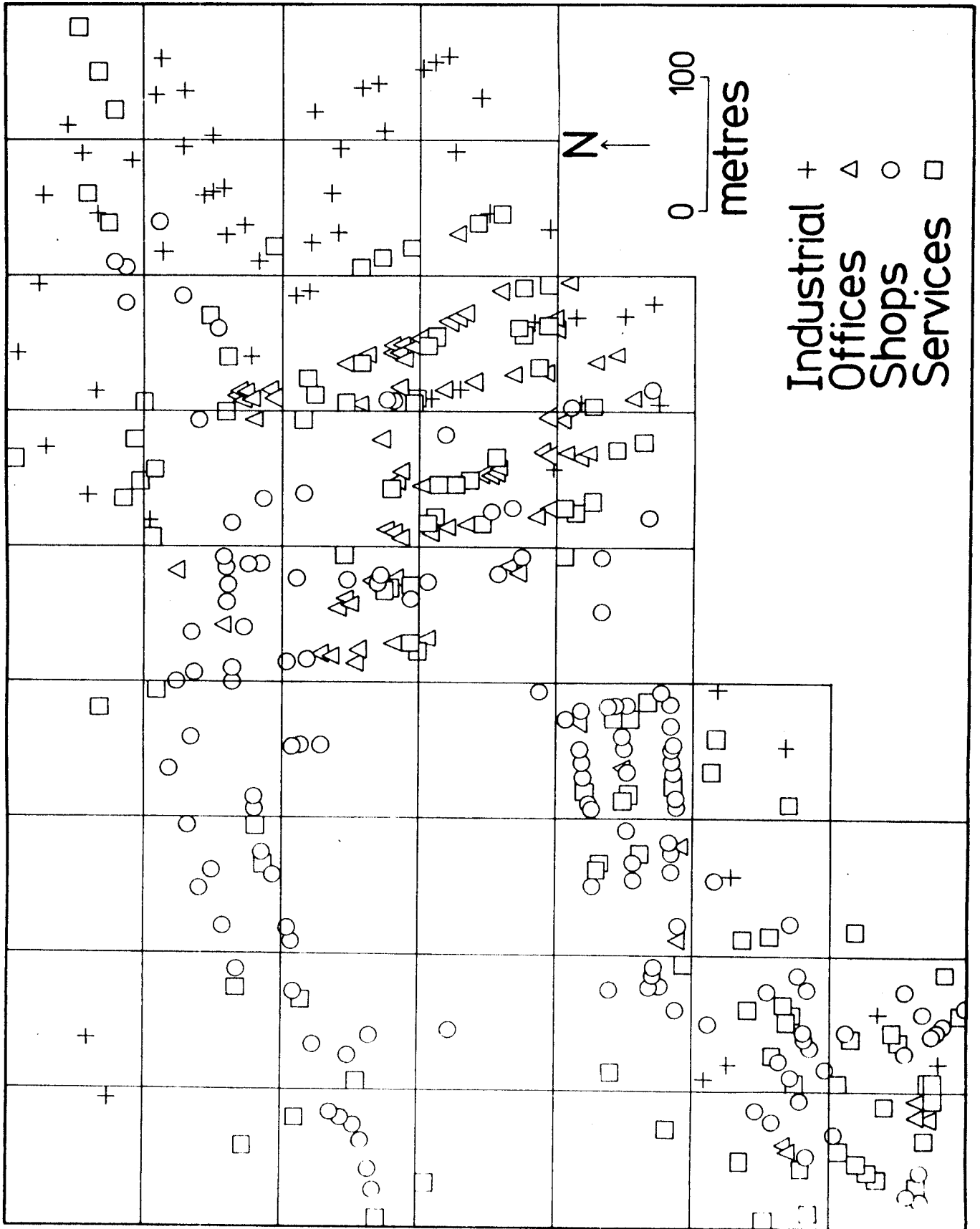

Fig. 31. Distribution of 'stayers'.

Table 18. Analysis of commercial 'Stayers' in Central Sunderland, 1966-1975

Cell No.	Retail	Office	Services	Industry	Total
1	4	3	8	0	15
2	8	0	8	2	18
3	0	0	1	0	1
4	4	2	4	0	10
5	10	0	6	2	18
6	2	0	2	1	5
7	0	0	3	2	5
8	0	0	0	1	1
9	6	0	2	0	8
10	8	2	3	0	13
11	22	2	7	0	31
12	2	0	1	0	3
13	1	3	5	0	9
14	2	6	1	5	14
15	0	0	1	0	1
16	1	0	0	0	1
17	0	0	0	0	0
18	1	0	0	0	1
19	3	3	1	0	7
20	2	13	7	1	23
21	0	9	8	3	20
22	0	1	2	3	6
23	0	0	0	4	4
24	6	0	2	0	8
25	4	0	2	0	6
26	2	0	0	0	2
27	3	0	0	0	3
28	7	10	5	0	22
29	1	6	1	0	8
30	2	10	5	2	19
31	0	0	3	4	7
32	0	0	0	4	4
33	0	0	1	0	1
34	1	0	1	0	2
35	6	0	2	0	8

Some principles of commercial change

The data in 'births', 'deaths', 'movers' and 'stayers' can now be used to provide some general statements on the nature and extent of commercial change in central Sunderland since 1966. By relating frequencies of each category for individual cells, it is possible to derive a measure of commercial change, and thereby some insights into the operational mechanisms.

Are commercial changes commensurate with population income, accessibility and other socio-economic parameters? What are the connections, if any, between births and deaths, in-movers and out-movers? Are turnover rates of commercial activity influenced by location, size of establishment, physical structures or by other factors? What is the expected life span of retail, office, service and industrial establishments? Are any of the changes hierarchical in character?

The present study cannot hope to answer all of these important questions. However, the close examination made over the years by the writer involving the exhaustive recording and processing of data, has revealed that the key elements are identifiable. The earlier spatial analysis and the behavioural insights offered in Chapter 7 suggest that it is possible to establish empirically the importance of these factors as determinants of commercial change. How universal these factors are in shaping the internal structure of commercial activity beyond central Sunderland is not clear until more similar studies are made.

The measures of commercial change have been computed to indicate degree and distribution. Firstly, totals of all 'births' and 'in-migrations' were compared with all 'deaths' and 'out-migrations' for each cell. The figures produced represent absolute differences and, therefore, appear as positive or negative (Fig.32, A). Secondly, an activity or turnover rate was calculated by summing the frequencies of each birth, death, in-and out migration for each cell. The mean for the 50 cells was computed and used as the base to classify cells with low, moderate, high and very high commercial turnover (Fig.32 B).

Both complementary measures reveal relevant aspects of commercial change. The dominating role of the new shopping centre is brought out by the first measure which shows that the greatest absolute gains are attributed to planned changes. The second measure shows the validity of the Murphy-Vance method of delimitation in that the cells with high and heavy rates of change fall within the delimited C.A. The second

A. Commercial change.

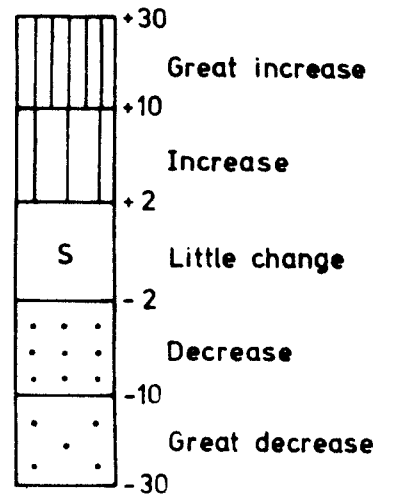
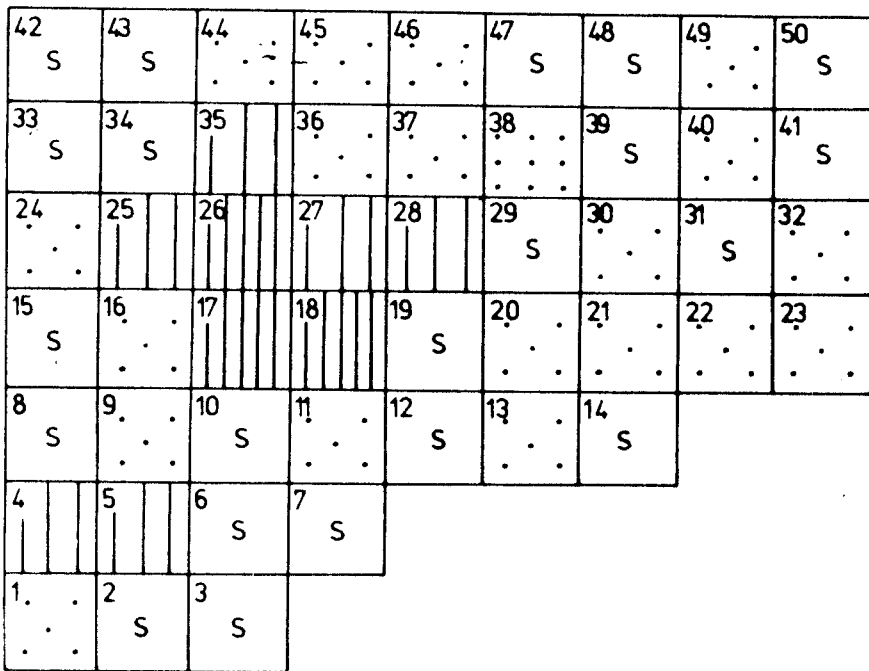

B. Commercial turnover.

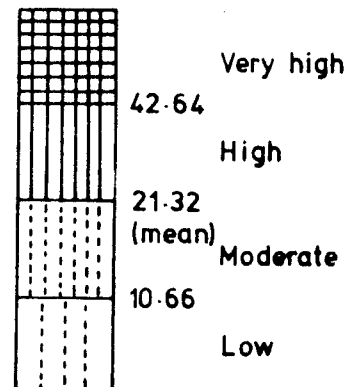
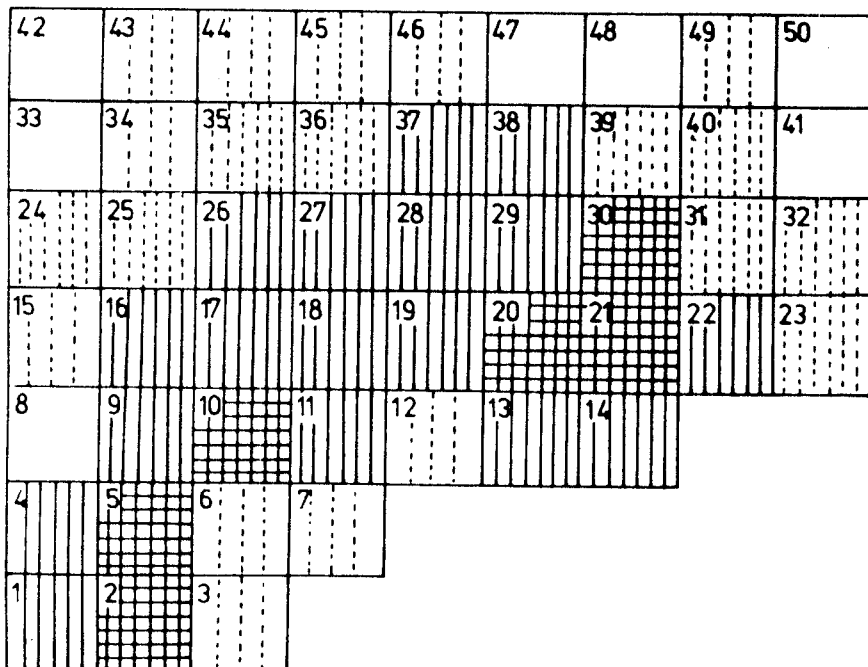

Fig. 32. Measures of commercial change, 1966-1975.

measure also demonstrates the importance of peripheral locations in generating some of the highest turnover rates. Two discrete peaks are apparent in Fig. 32, (B): (a) cells 20, 21 and 31 which lie east of the retailing core and form part of the office area in John and Frederick Streets; (b) cells 2, 5 and 10 which are located in the Vine Street area to the south west of the retail core. Significantly, these peaks correlate with areas which, on the one hand, have older, cheaper properties, suitable for newer, smaller establishments, and on the other, are sufficiently close to the main streams of pedestrian activity to be classed as desirable. Away from the core cells, levels of commercial change generally decline in response to the decreasing numbers of commercial establishments in non-central cells. The patterns of commercial change outlined above can be largely attributed to the varying relationships of 'births' to 'deaths' and in to 'out-migrants' over the 50 cells.

To examine the relationship between the frequency and distribution of 'births' and 'deaths', a number of normal statistical procedures were applied. Firstly, the data were plotted as a scattergram (Fig. 33) to show a broadly positive relationship. Cells which contain a large number of 'births' also tend to contain a large number of 'deaths'. Secondly, the product moment correlation <sup>(16)</sup> was calculated and found to be 0.64. Thirdly, the regression lines were derived by the least squares method <sup>(17)</sup>. By two derived equations:

$$y = 0.74x + 2.47 \quad (1)$$

$$x = 0.55y + 2.80 \quad (2)$$

are plotted as straight lines on the scattergram by taking two values of the 'births' and 'deaths' and calculating the corresponding values of the other variables. Lines were drawn through the resulting coordinates.

The regression lines draw attention to the differences in relative importance of 'births' and 'deaths' in 50 individual cells for which data were collected. The further a point is from the diagonal, the greater the difference its value is from the expected. Furthermore, by employing the equation directly it is possible to interpolate and predict a value of one variable from a given value of another. For example, cell 26 has 22 'births' recorded. The expected number of deaths calculated by the formula

$$y = 0.74x + 2.47$$

would be 18.75. In actual fact, the number of 'deaths' is only 1. The considerable amount of commercial change in cell 26 brought about by the 'births' of new establishments cannot be accounted for, and accommodated by equivalent 'deaths' of old establishments. In this instance, entirely

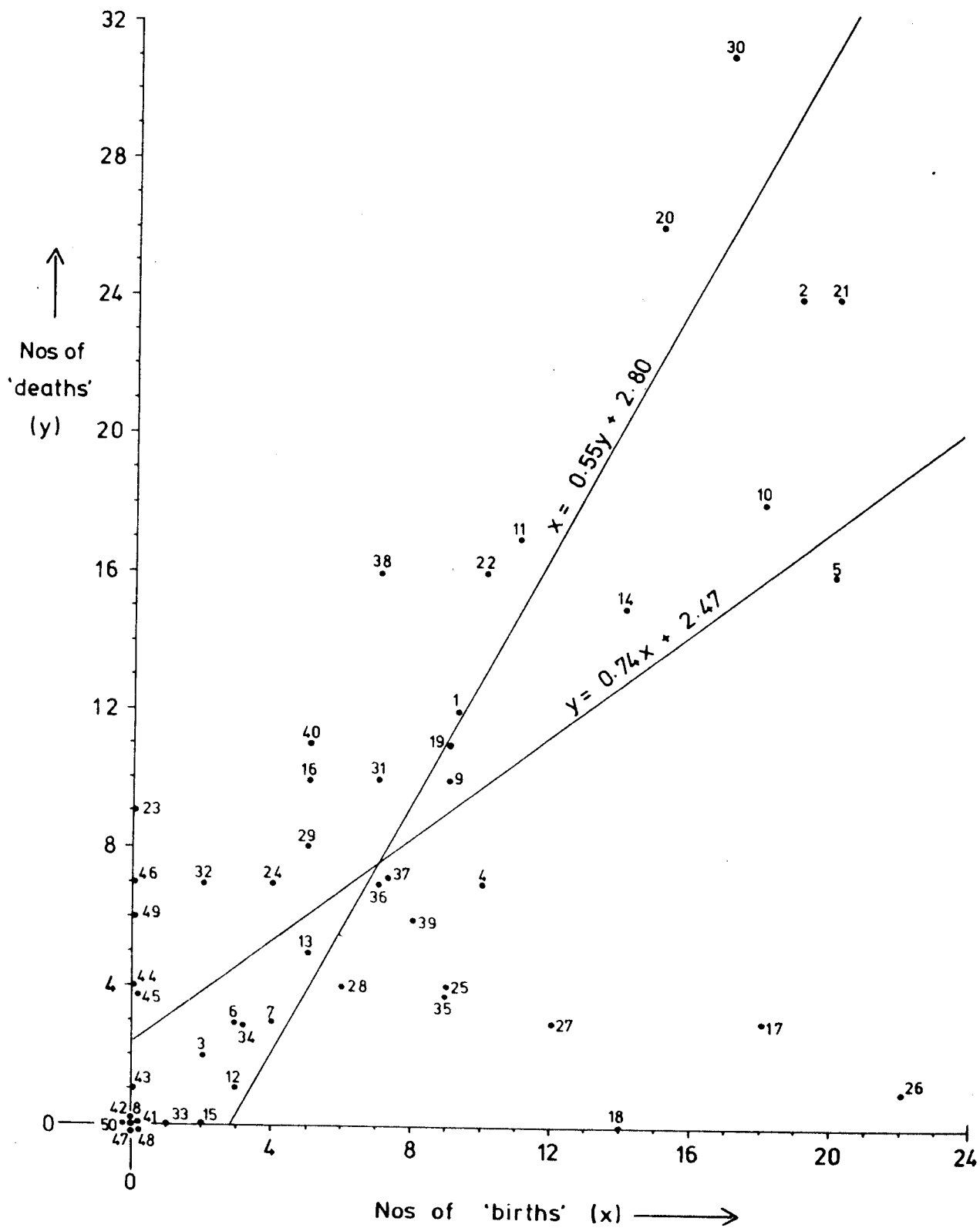

Fig. 33. Relationships of 'births' and 'deaths'.

new physical structures were provided by the central area redevelopment scheme which added to, rather than replaced, existing commercial premises in central Sunderland. On the other hand, in cells 14,5 and 21, the regression model gives a close prediction of actual and expected values.

The relationship between 'in-migrants' and 'out-migrants' was explored in a similar manner to 'births' and 'deaths'. The hypothesis that in - and out - movements of commercial establishments are associated was tested by regression.

Data are plotted to produce a scattergram (Fig.34). Again a positive correlation exists between the two variables but with a reduced value (0.56). This value is significant at the 0.07 level. The two regression lines are derived from the two equations:

$$y = 0.55x + 1.40 \quad (1)$$

$$x = 0.56y + 1.53 \quad (2)$$

and are plotted in the same way. As before, the equations facilitate, by substitution, the comparison of expected and actual values.

Another factor underlying commercial change relates to the structural condition of premises. Turnover rates are high in the oldest and newest structures. To understand this apparent contradiction one must consider the physical structure as being composed of a large number of characteristics, including internal arrangement, age, value, quality, tenure conditions. Properties in Frederick Street are old, sub-divided, leased on short terms, and less fashionable for commercial activity. They attract large numbers of new establishments beginning their commercial life. Many of these die without becoming established as has already been mentioned. Properties in Market Square, on the other hand, are purpose built, expensive and valuable. They attract a different sort of commercial establishment: one that has been successful elsewhere, one that has greater capital supporting it and greater manpower reserves. Most of these are retailing establishments.

In both areas commercial change is high due to the inherent structure of the premises being suitable for a particular but different type of establishment. The conclusion that commercial change is significantly influenced by the nature of buildings can be substantiated by reference to Fig. 16.

Commercial turnover is also closely related to the size of establishment, with the highest mortality rates being experienced by small operators. No data on numbers employed by commercial establishments in central Sunderland would be released by the Department of Employment. However, from personal field work it was clear that the highest rates of

births and deaths were found in establishments with less than 5 employees. These establishments were generally disadvantaged in experience, capital funds and imperfect market research. In times of economic stringency these small businesses were most likely to die.<sup>(18)</sup> Small commercial establishments, irrespective of the nature of their activity, tend to be consumer orientated and more sensitive to short term changes in market conditions.

From the interviews held, either formally or informally, it was evident that commercial change in a C.A. is of great complexity, involving an intricate system of organisation, decision-making and support. Some establishments were functionally and/or organisationally linked to others. The fortunes of one impacted on another and set in a chain of reactions, often with a spatial outcome. Individuals operating in one commercial establishment would sometimes switch their interest from one type of activity to another without always any obvious pattern or rationality.<sup>(19)</sup> The uncertainty of these human decisions make the analysis of commercial change fraught with difficulties and suggests that randomness must be included in any model of commercial change.

Finally, there is evidence that commercial change in the C.A. is affected by its hierarchical relationships with other centres. The C.A. of Sunderland lies, in terms of functional importance, between the C.B.D. of Newcastle upon Tyne and surrounding suburban and outlying minor centres of the region. Commercial change between both ends of the settlement hierarchy represents a flow<sup>(20)</sup> manifesting itself in Sunderland's C.A. at two distinct levels: (a) between the C.A. of Sunderland and the C.B.D. of Newcastle; (b) between the C.A. of Sunderland and surrounding suburban centres and smaller towns.

At the first level, very few commercial establishments moved up the hierarchy from the Sunderland C.A. to the Newcastle C.B.D. On the other hand, considerable 'trickling down' was recorded whereby firms, mainly but not exclusively, retailing, established new outlets in central Sunderland from a base in Newcastle. These births represent a deliberate decision, on behalf of the parent firm to expand, diffuse and locate in other C.A. s. Sunderland, as the second longest settlement in the area, attracted most of these attempts.

At the second level, a greater reciprocal interaction is observable in the flow between the Sunderland C.A. and surrounding local and suburban centres. This symbiotic relationship can be illustrated with reference to offices and retail and service establishments.

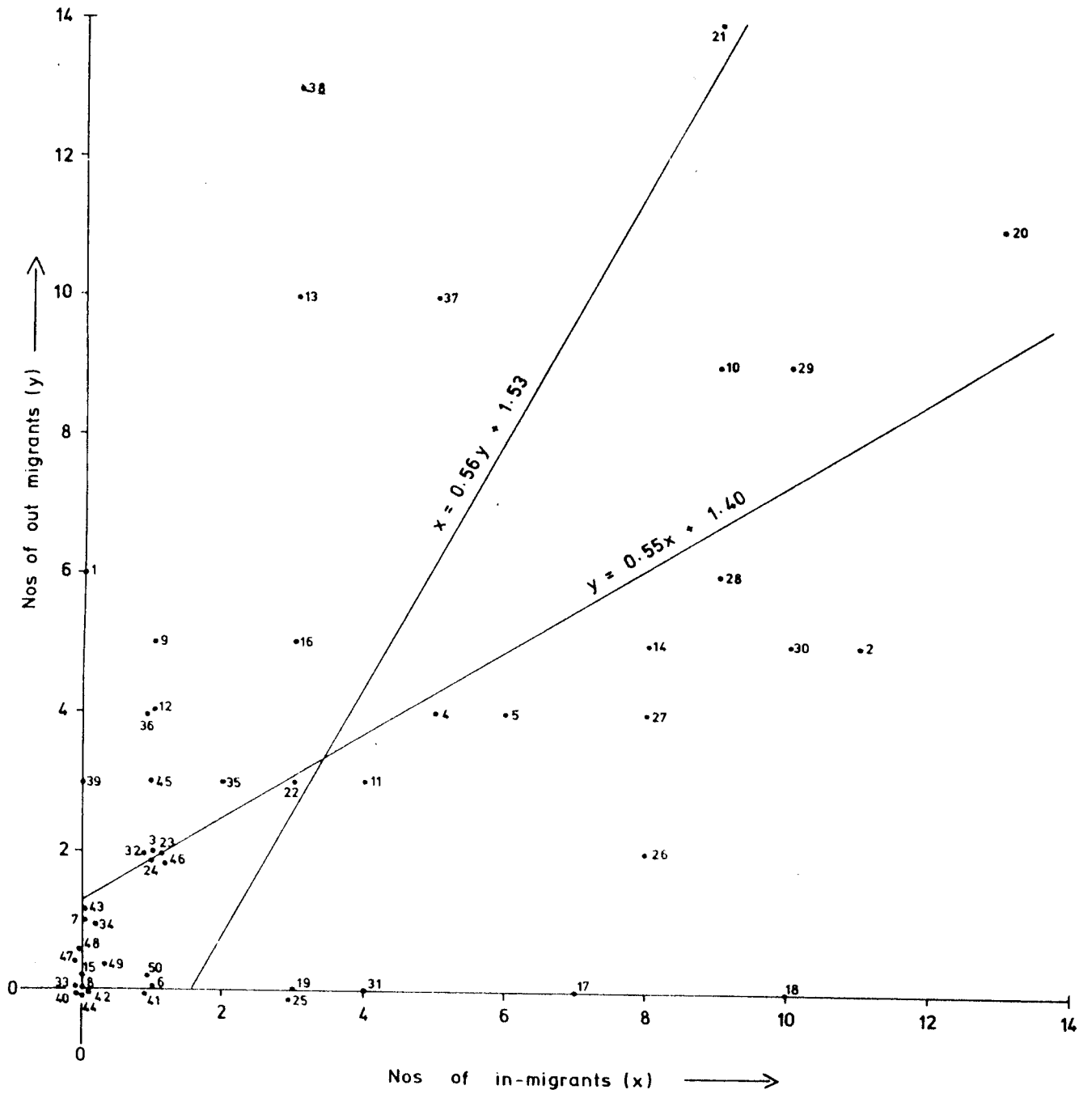

Fig. 34. Relationship of in-and-out migrants.

Some newly established offices, namely estate and insurance agents, find the competition from existing rivals too great in the C.A. and spread out into suburban centres and surrounding towns. The dispersion of offices and sub-offices into Ryhope, Seaburn and Houghton-le-Spring was not an uncommon observation and represents the spatial expression of this process.

Other enterprises, usually small shops and miscellaneous services moved from an out-of-town location into the C.A. These in their search for commercial success, tended to locate in more peripheral properties where vacancies are more frequent and costs are less prohibitive.

Both processes reflect successful commercial ventures, the former of larger more prosperous businesses, the latter of smaller operations. The mortality rate is highest in this latter category. A much deeper analysis of these mechanisms is, however, needed to explore precise relationships; and the spatial analysis presented above must be supplemented with some behavioural considerations.

#### Summary

Numerical changes in the commercial population of central Sunderland have been investigated, by applying the concept of birth-life-death to individual establishments in the period 1965-1975. Locational patterns of 'births and 'deaths' were observed and related to the nature of the activity, age and condition of property and fashionability of particular areas within the C.A. The process of the relocation of establishments was studied by measuring distance and directional bias. The rate of commercial change in the C.A. was mapped according to a number of criteria, and related to inter and intra C.A. flows.

References and end notes

- (1) The Report on the Census of Distribution and other Services, (1966), broadly adopts the distinction; Beesley, M., (1955), 'The birth and death of industrial establishments: experience in the West Midlands conurbation', Journal of Industrial Economics, Vol.4, pp. 45-61; Collins, L., (1973), 'Industrial size distributions and stochastic processes', Progress in Geography, Vol. 5, pp.120-165.
- (2) In British contexts; office establishments have often been studied from the viewpoint of decentralisation and relocation at the regional level (eg. Townroe, P.M., (1971), 'Industrial location decisions: a study in management behaviour', University of Birmingham, Centre of Urban and Regional Studies, Occasional Paper, No. 15. Similarly, retail establishments are often studied from the viewpoint of how they cluster or disperse (eg. Davies, R.L., (1972), 'Structural models of retail distribution', Transactions of the Institute of British Geographers, No. 57, November, pp. 59-82; Wild, M.T., and Shaw, G., (1974), 'Locational behaviour of urban retailing during the nineteenth century: the example of Kingston upon Hull', Transactions, Institute of British Geographers, No. 57, pp.101-117.
- (3) For a discussion on the philosophical, methodological and operational relevance of frameworks in geographical research see: Walmsley, D.J., (1972), 'Systems theory: a framework for human geographical enquiry; H.G./7 Research School of Pacific Studies, Australian National University, Canberra.
- (4) Birth, life, death concepts have been adopted in a wide range of other geographical research: Beesley, M., (1955), op.cit.; Berry, B.J.L., Parsons, S.J., and Platt, R.H., (1968), 'The impact of urban research on small businesses: the Hyde Park-Kenwood case'. Centre for Urban Studies, University of Chicago; Cowan, P., Fine, D., Ireland, J., Jordan, G., et.al. (1969), 'The office: a facet of urban growth'; Collins, L., (1973), op.cit.
- (5) The terms: stayer and mover have also been used in a variety of situations: Brown, L.A., (1970), 'On the use of Markov chains in movement research', Economic Geography, (June), pp. 393-403.
- (6), In the early stages of this work these types of establishments were separated but conceptual and practical confusion persuaded the
- (7) writer to combine them. Thus, an establishment relocating fro, for example, Yorkshire is classified as a 'birth' and an establishment relocating from central Sunderland to any other area is classified as a 'death'.
- (8) Summarised in correspondence with Mr. N. Dibben, Planning Department, Civic Centre, Sunderland, 8th June, 1976.
- (9) Post Office directories are used to examine intra-urban functional change by Lever, W.F., (1972), 'The intra urban movement of manufacturing: a Markov approach'. Transactions, Institute of British Geographers, No. 56, July, pp. 21-37.
- (10) Report on the Census of Distribution and other services, (1966) Appendix A, Section 31, Pl/135, Board of Trade.
- (11) Refer to Fig.11 for cell numbers.

- (12) Since the preparation of this section, Blandford Street has been changed from a street with two-way traffic and limited parking to a fully pedestrianised area.
- (13) Berry, B.J.L., et al.(1968), op.cit.
- (14) An instructive indication of the role of planning decisions in influencing the location of commercial activity in central Sunderland is given in the SUNDERLAND STRUCTURE PLAN: Summary Report No. 1, Town Centre, 1971. The report, with its numerous maps analyses planning applications since 1947 and portrays the resulting patterns. Some of these findings confirm the present writers analysis and are referred to in the text.
- (15) See, Adams, J.S., (1969), 'Directional bias in intra urban migration; Economic Geography, Vol. 45, January, No. 1, pp.302-3.

## Chapter 7

### SOME BEHAVIOURAL ASPECTS OF COMMERCIAL CHANGE IN CENTRAL SUNDERLAND

#### Introduction

Earlier chapters have concentrated on the spatial structure of commercial change. even though it was apparent early in this study that spatial patterns and processes are often the outcomes of behavioural factors. Decisions and strategies of individuals and institutions play crucial roles in influencing the form and extent of commercial change. This chapter, therefore, sets out to redress some of the balance by investigating the nature of these factors and by assessing their significance in the spatial dynamics of C.A. change.

Three complementary levels of investigation are attempted. Firstly, the contemporary locational strategies of retail and office activities are viewed from the point of view of resultant terminal distributions. Secondly, the attitudes of individuals and firms in deciding to relocate or not are explored. Thirdly, the spatial history of two major firms is presented as case studies of some of the issues.

#### Spatial behaviour and locational strategies: shops and offices

The terms 'spatial behaviour' and 'locational strategy' are applied in this section to those behavioural outcomes of the decision-making process which have a spatial dimension. Retailing and 'office' activity are selected to provide examples of contrasting strategies and behaviour.

Theories which contribute to the understanding of the spatial behaviour of commercial establishments suggest a common set of factors which, together, influence the locational strategies of firms. These factors relate to three facets of commercial life: (i) the consumer, (ii) the urban system, (iii) the establishment.<sup>(1)</sup> Their relevance in the real world is perhaps best demonstrated by the tendency of urban functions to concentrate or disperse. Researchers<sup>(2)</sup> suggest that two major locational strategies are available to the decision makers of commercial establishments: the intercepting strategy and the clustering strategy. An interceptor location is one which is situated between the customers and establishments. A clustered location is one where the establishment is grouped, for reasons of cumulative attractions, with other establishments of the same or related functions. These strategies, as viewed by industrial

managers and directors of commercial establishments in central Sunderland, are revealed in survey results presented in the next section.

Before individual cases are examined, however, the aggregate spatial behaviour of retail and office establishments in the C.A. should be analysed. The techniques available to the geographer are many and varied. Here, three of the more elementary statistics included in point pattern analysis literature<sup>(3)</sup> are used. Together, they describe the behaviour of retailing and office functions and begin to bring the various theoretical assumptions, mentioned above, under scrutiny.

The three measures are:

(i) the mean centre of a point distribution which is defined as that point at which  $\int r^2 D dA$  is minimised where  $r$  is the distance from each area to the point and  $D$  is the density for an area of size  $dA$ .<sup>(4)</sup>

(ii) the standard deviation of a point distribution which is expressed as  $S = \sqrt{\frac{\sum (x - \bar{x})^2}{n}}$  where  $\bar{x}$  is the mean centre of the distribution and  $\bar{x}$  refers to the straight line distance of individual points from the mean centre.

(iii) the nearest neighbour technique ( $R_n = \frac{\bar{d}_o}{\bar{d}_e}$  where  $\bar{d}_o$  is the mean distance between nearest neighbours points observed and  $\bar{d}_e$  is the mean distance to be expected from a similar number of points randomly distributed in the same area.

The application of these techniques has been widespread both in central area literature<sup>(5)</sup> and in the study of the intra urban functions.<sup>(6)</sup> In particular, two contributions stand out for their relevance in focussing on the spatial and temporal aspects of commercial change: Getis,<sup>(7)</sup> measured dot distributions of grocery establishments for successive time periods and then computed the extent and the way in which the point patterns departed from the random expectation. Sherwood<sup>(8)</sup> examined the intra urban movement of two independent functions - grocery stores and solicitors/accountants - and also computed changing measures of observed and expected distances in order to gain insights into the "temporal process of reorganisation"(p.42).

Two major difficulties confronted the present writer in applying these approaches to the retail and office functions of central Sunderland. Firstly, centrogographical and nearest neighbour techniques suffer from a scale and boundary problem. They can certainly be applied to the whole urban area as Getis, Sherwood and Rogers show, but not so meaningfully to central areas which represent only a part of the total urban system.<sup>(9)</sup>

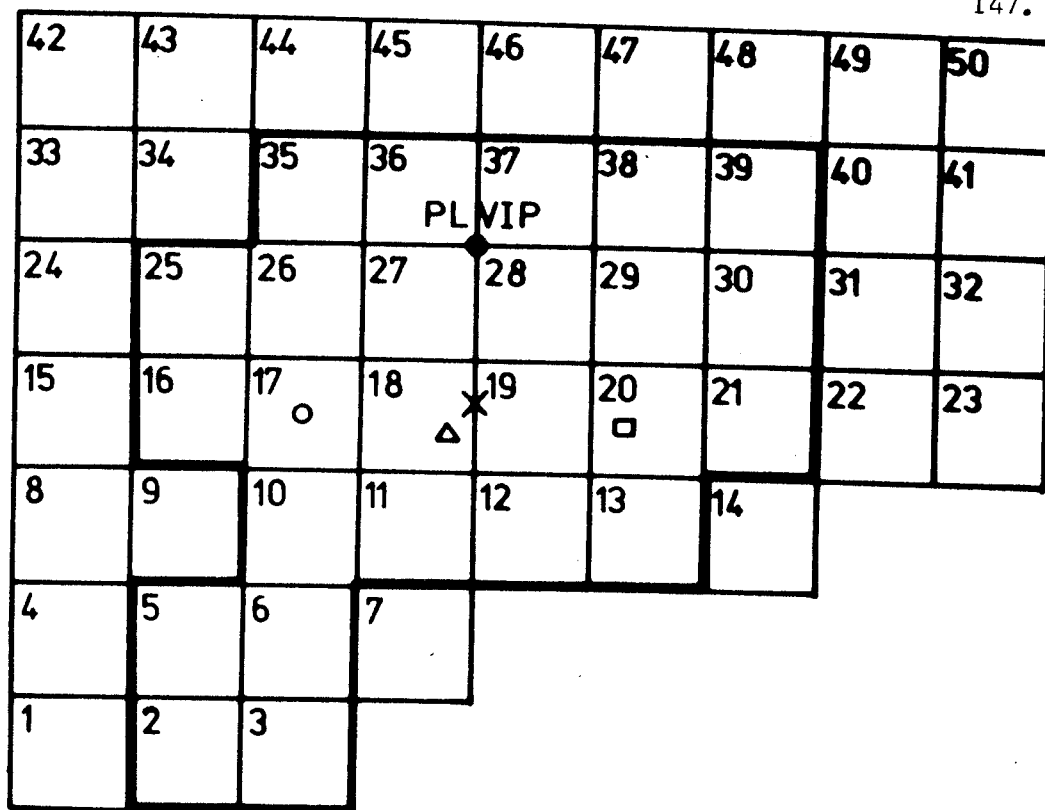

- ◆ PLVIP Peak land value intersection point
- x Centroid of all commercial establishments 1975
- o Centroid of all retail establishments 1975
- Δ Centroid of all service establishments 1975
- Centroid of all office establishments 1975

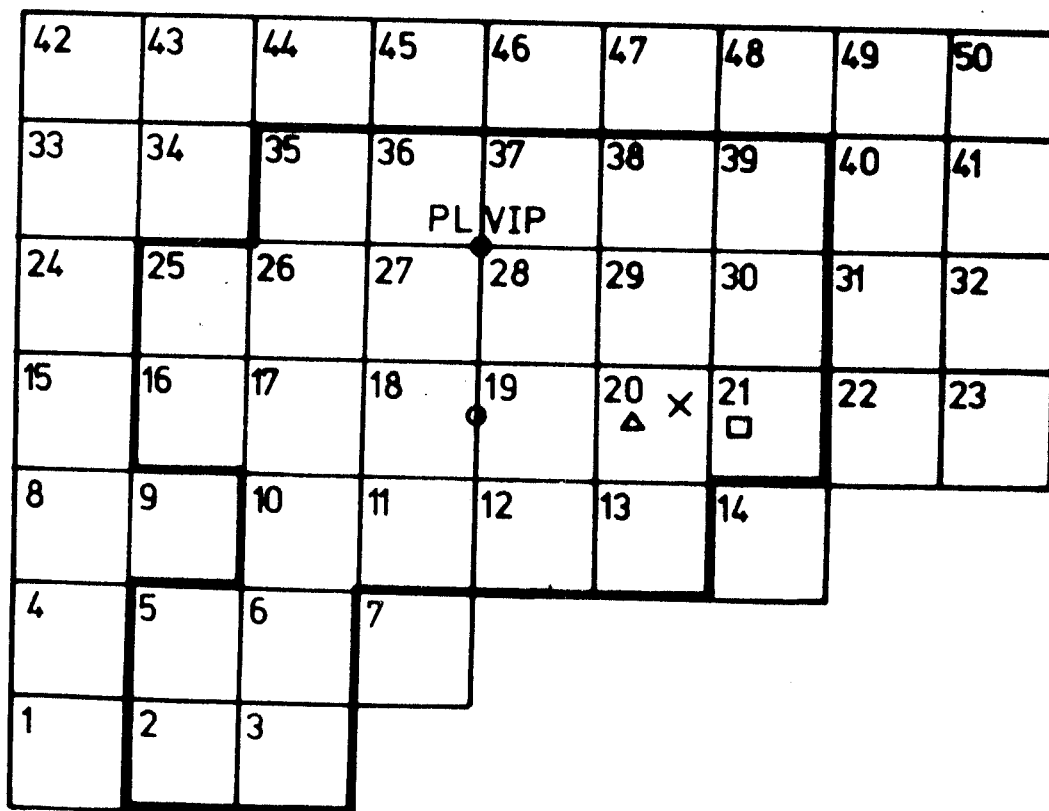

- ▭ CBD limit
- x Centroid of solicitors
- Δ Centroid of insurance agents
- Centroid of estate agents
- o Centroid of banks and building societies

Fig. 35. Mean centres of urban functions.

The delimitation of a central area truncates a point distribution of any urban function which, in reality, usually continues into the outer and surrounding areas. Secondly, there are no comparable <sup>(10)</sup> sources which are readily available for Sunderland which provide specific locational data on urban functions for a continuous time series. Moreover, it can be agreed that usual sources, such as directories, under-represent certain urban functions <sup>(11)</sup> in point pattern studies. The results and interpretation to therefore, are not to be considered as a definitive illustration of the patterns and processes; rather they provide an exploratory indication of the scope of such approaches to the C.A. of Sunderland.

#### (i) Shops

The mean centre of retail establishments was computed for 1894, 1927 and 1975. The 1975 figure is based on the field survey described in Chapter 5, and located in Fig. 35. Of all the selected functions, it is the most westerly in the C.A. and the most mobile. Comparative mean centres were calculated for 1927 and 1894 from the Goad fire insurance plans. Accepting that map coverage is not complete and that only ground floor shops are recorded, it is clear that the centre of retailing has migrated about one hundred and fifty metres since 1894.

The rate of migration which accelerated in the late 1960's, due to planned redevelopment has, in the 1970's, slowed down. Furthermore, the impact on the new centre on retailing was not uniform, as can be seen by comparing the changing behaviour of food shops and furniture stores between 1962<sup>(12)</sup> and 1975. Food shops were selected because they represented the category of shops which can be termed convenience: i.e. they depend on regular and frequent purchases. Furniture stores, on the other hand, depend more on periodic purchases, as well as needing more space. A reasonable hypothesis would be therefore, that the spatial behaviour of the two categories over the contemporary period of C.A. reorganisation would differ. The hypothesis is examined by reference to Fig. 36 A and B.

In 1962 (A), both types of shops were dispersed around the major shopping areas reflecting the linear and non-centralised configuration of retailing at that time. Although numerically superior, food shops were, like furniture shops, dispersed to intercept the incoming streams of shoppers from the surrounding residential areas.

By 1975 (B), these streams converged on the new bus terminal located in the new shopping precinct. Furthermore, retail and service facilities

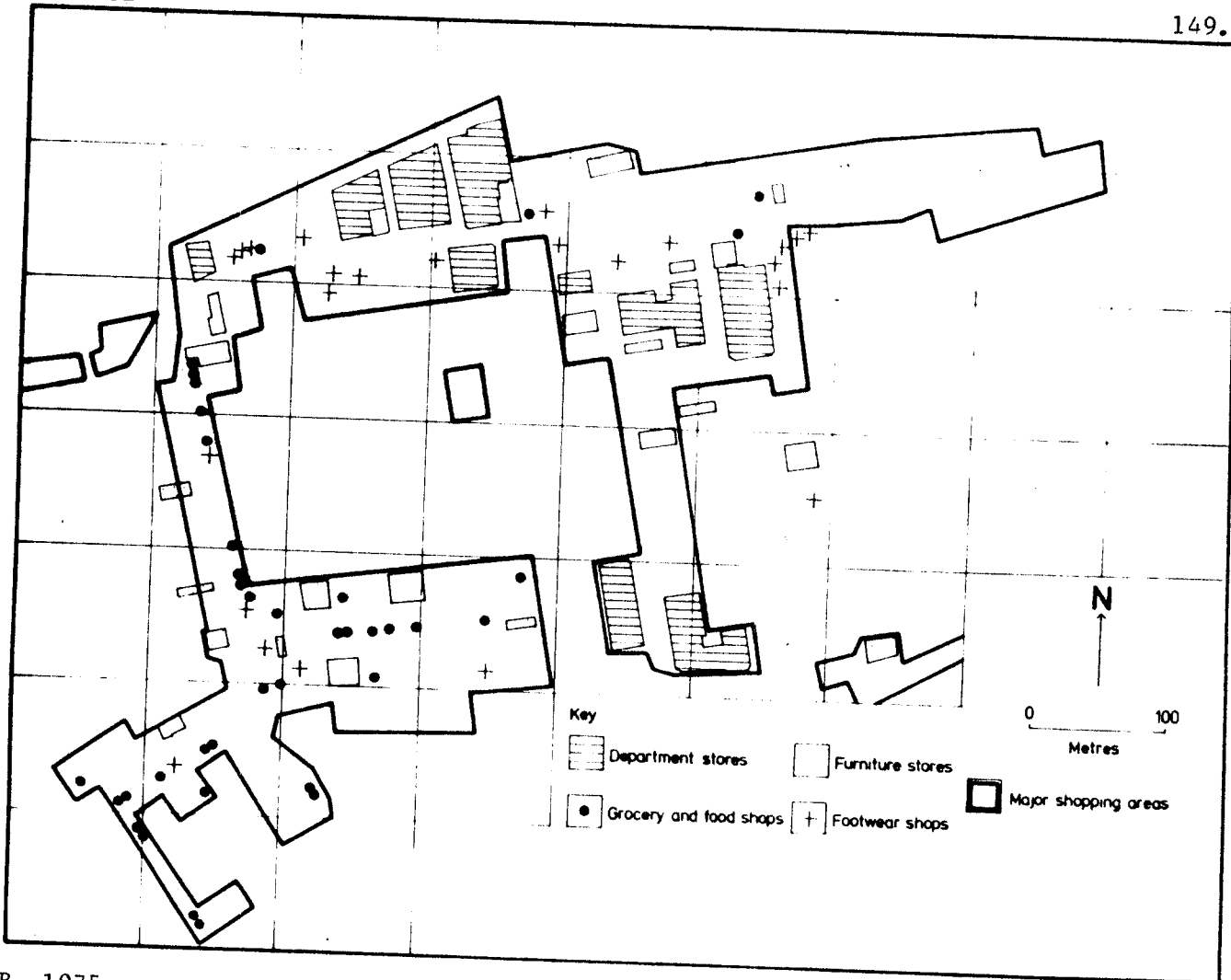

B. 1975

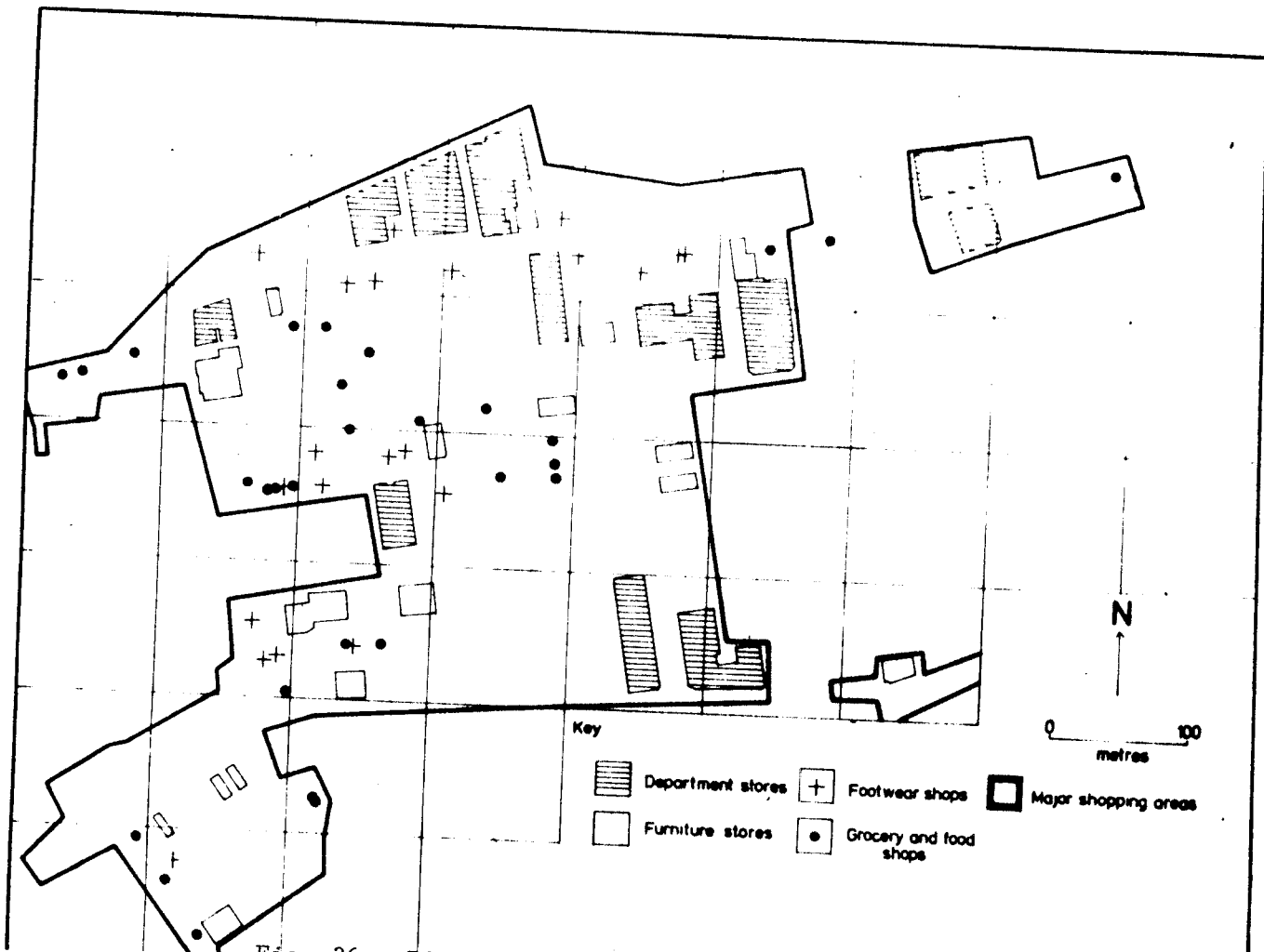

Fig. 36. Distribution of shop types, 1962(A) and 1975(B).

retail and service facilities were provided in the new precinct and these twin developments forced shops and furniture stores to reconsider their locational strategies. The 1975 map shows the outcome of the multiple decisions which were made. There is clear evidence, supported by field work and personal knowledge, that food establishments placed great reliance on commanding central sites where peak pedestrian flow was concentrated. The clustering of major food shops in Market Square, and Walworth Way reflects the desire of these establishments to intercept as many consumers as possible. The inter-play of the cluster and inter-ceptor strategies, however, is not by any means straight forward.

Furniture stores also need to intercept consumer traffic as well as being in a location to benefit from proximity to other furniture establishments. However, in 1975, they remained as in 1962 in more dispersed locations and in less central streets. Only two firms made the decision to locate in the new centre. The other new furniture outlets favoured off-centre locations but in the main paths of pedestrian movement, eg. cell 10, which lies between the Park Lane bus station and the new shopping centre.

#### (ii) Offices

The shift of the retail centre away from Fawcett Street and High Street West has been a phenomenon influenced by three sets of factors: (a) the residential growth of Sunderland (b) transport and communication developments (c) the physical and economic obsolescence of properties. The locational preference of retailing for the western half of central Sunderland is therefore, not surprising.

The behaviour of office establishments, however, has been rather different both in the long term and the short term. In the long term, since at least the turn of the century, the office core in Sunderland has, not shown any marked tendency to expand or migrate. The 'office quarter' has remained in the same area since its establishment at the end of the nineteenth century. The degree of spatial clustering is illustrated by reference to Fig.37 which maps the point distribution of solicitors, insurance agents, banks/building societies and estate agents for 1975.

Interesting variations in their spatial behaviour are apparent and worth further analysis. Nearest neighbour measures were computed for the four activities and standard deviation values derived.

Banks and building societies have been grouped together; as activities which have considerable financial backing; their locational strategies are less constrained by financial consideration than some

A. Insurance Agents

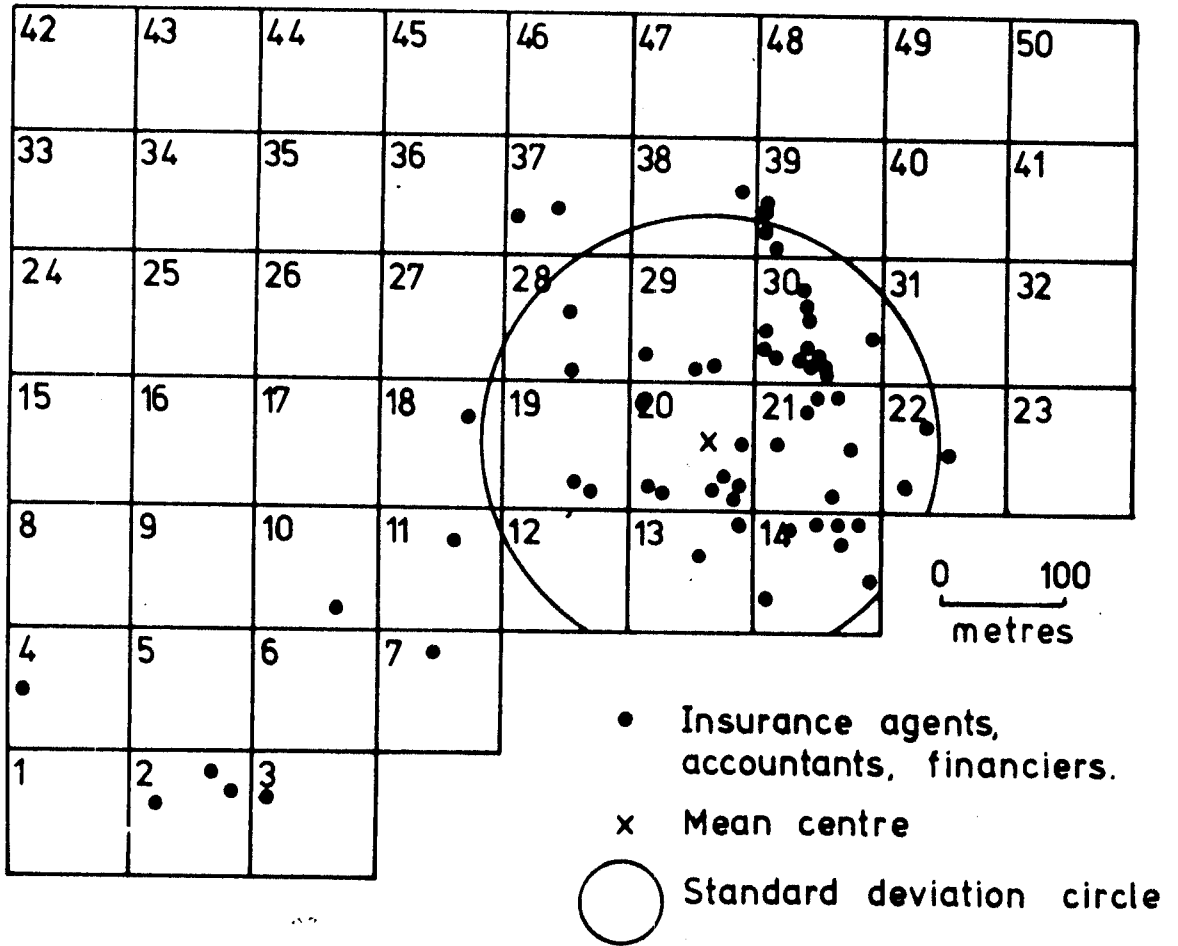

B. Banks and Building Societies

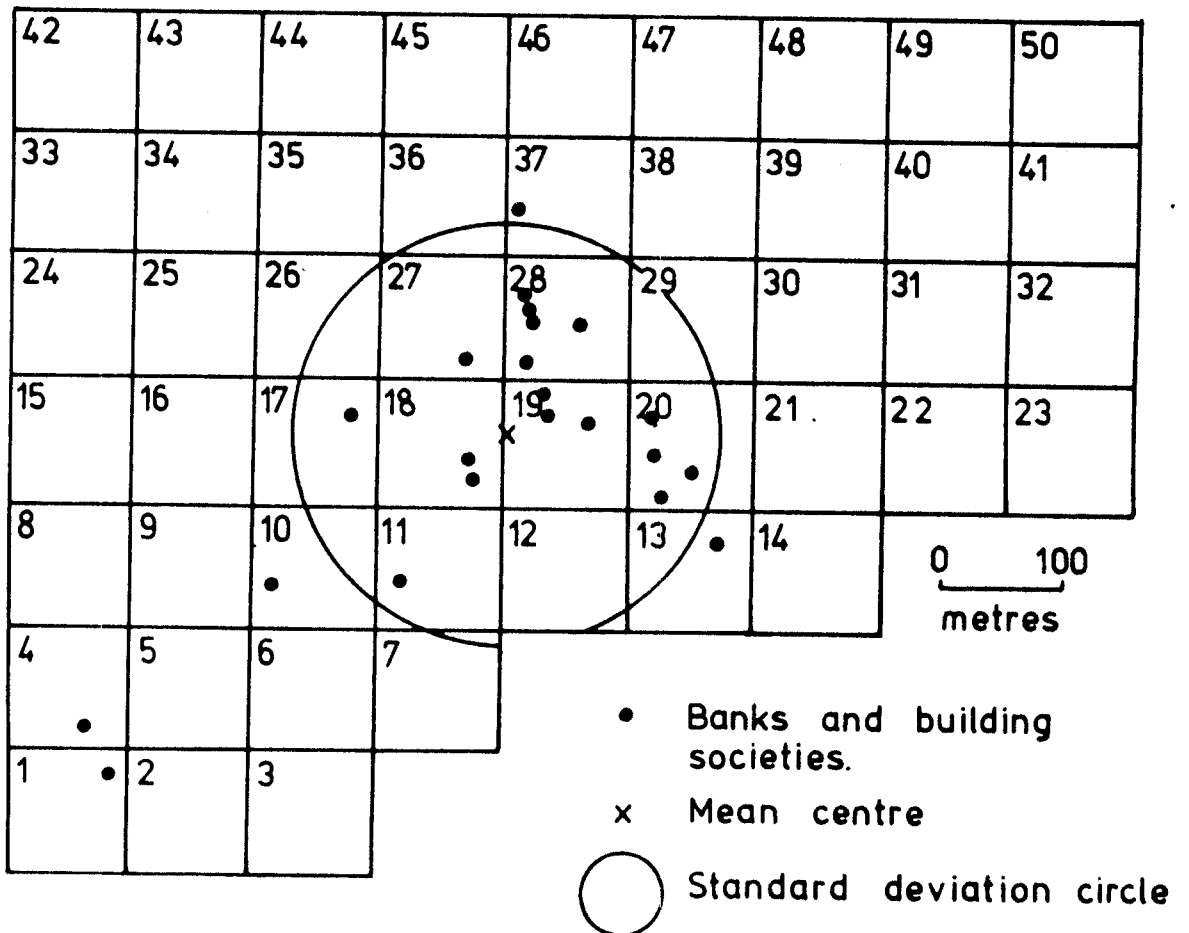
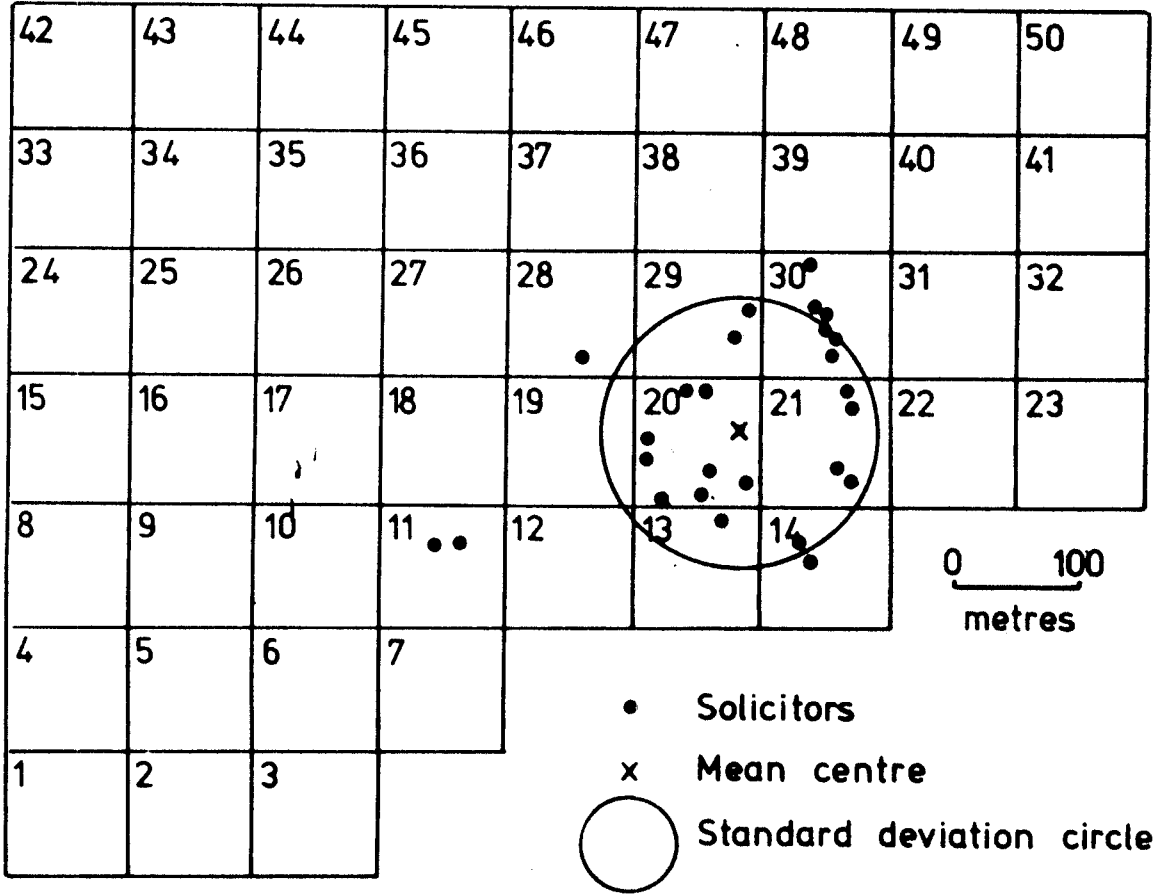

Fig. 37. Distribution of office establishments, 1975.

C. Solicitors



D. Estate Agents

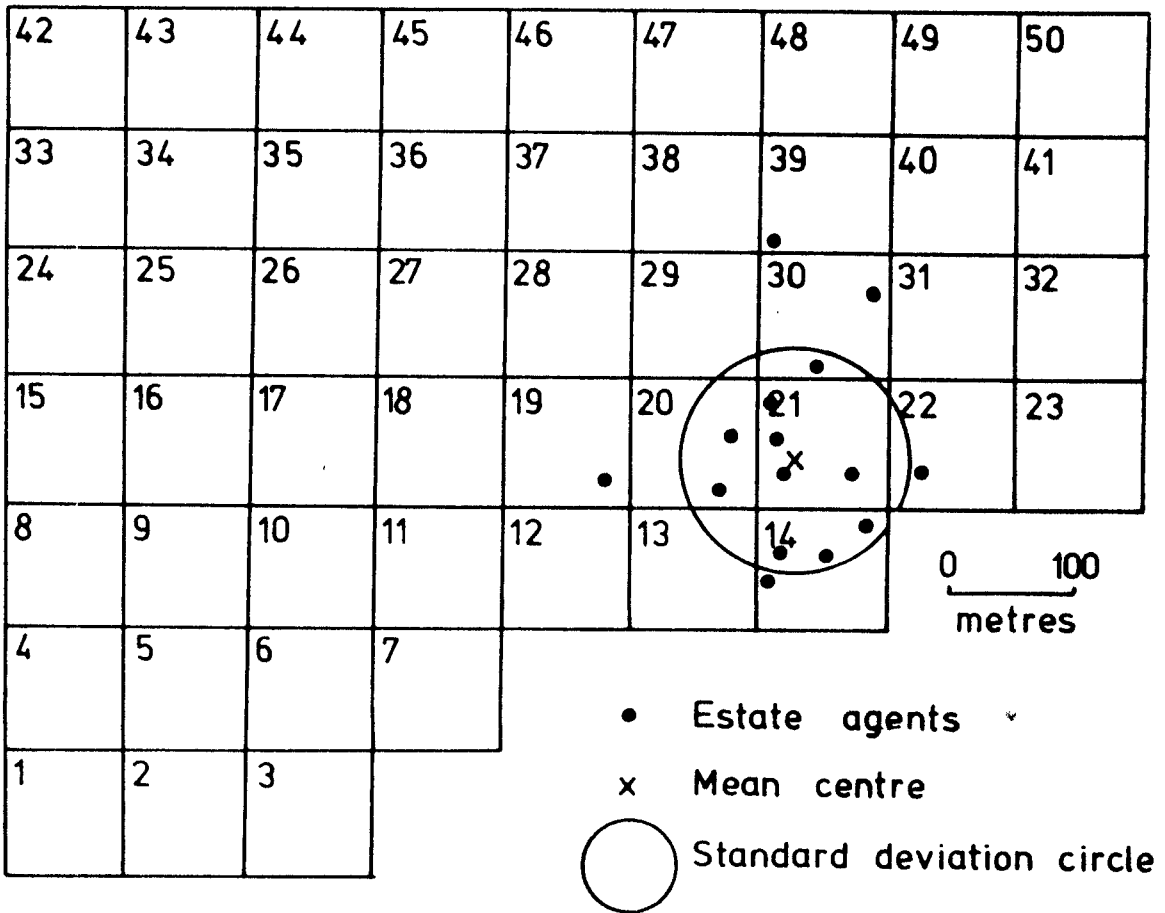

Fig. 37. Distribution of office establishments, 1975.  
 (continued)

others. The  $R_n$  value for this group was found to be .553. The main banks are all located in Fawcett Street, with the exception of one in Bedford Street. The westward migration of commercial (retail) activity into streets such as Maritime, Derwent and Vine Streets has caused some recent reappraisals of locational strategies. The Yorkshire Bank, Barclays and Lloyds Banks have all opened branch offices in these streets in the last ten years. In the case of the first named bank, the decision to locate away from the traditional banking core was based on: (i) distance from the domination of the 'big' banks (ii) location in an increasingly prosperous commercial street (iii) lower costs. (13)

Building societies demonstrate similar spatial behaviour patterns to banks. Traditionally, they have preferred sites in the office core. But with the westward migration of commercial activity and the pull of the new shopping centre, old locations have been reappraised. The 'Halifax', the largest building society, relocated from its Atheneum Street site to Market Square. Two other societies opened branch offices in the planned precinct to take advantage of the newly concentrated pedestrian activity.

The mean centre of banking and building societies is now only 150 metres to the east from the mean centre of retailing as a result of these recent locational strategies.

Another activity which is characterised by more marked clustering is solicitors, the  $R_n$  value being only .315. Solicitors, furthermore, exhibit the greatest resistance to change. No solicitors have opened offices in the new precinct and only one has been sited, as a branch office, in a C.A. street outside the traditional office area. The spatial immobility of solicitors is a well-known phenomenon. It is related to their specific locational requirements, such as well developed linkages within and with other professional groups. The mean centre of solicitors is over 200 metres from the mean centre of retailing and tending to increase. As a user of C.A. commercial space, it does not place pedestrian contact high on its location strategy list, a fact which is supported in that few solicitors' offices are on street level.

Estate agents cover a wide range of practitioners from well-established, large firms to new and smaller outlets. Generally, the former are more spatially stable than the latter. The  $R_n$  value for this group was found to be .504. The mean centre is located in cell 21, which is east of the mean centre of solicitors. Again the cluster strategy is

strong for this group. One interesting departure of traditional locational strategy is the 'birth' of a new estate agents office in Athenaeum Street. This site is very close to the Electricity Show Rooms to which the public come regularly and repeatedly to pay bills, and within 100 metres of Binns, an 'anchor' business. This new outlet occupies an excellent location 'intercept' customers before they reach its competitors in the more traditional estate-agent core further east.

Insurance agents and financial consultants cover a very wide range of large-, medium - and small sized firms all offering some sort of financial service to the public. They are the relatively more dispersed with an  $R_n$  value of .528. They are accommodated in a wide range of premises including a ground floor unit in the new shopping centre, properties in the traditional office-dominated John Street, and a basement unit in Foyle Street. The standard deviation circle describes the degree of dispersion. Many of these businesses place consumer contact high on their locational strategy list, particularly the newer and less well established ones.<sup>(14)</sup> Against this powerful factor is the conflicting force of higher costs of more central locations. The spatial behaviour of 'insurance' offices is less predictable than the others.

The present configuration of commercial structure in the C.A. is the result of past and existing locational policies. The behaviour of establishments over time and space depends on a variety of considerations according to their functions. Some of these have been identified above and may be summarised as:-

- (i) proximity to competing and complementary establishments
- (ii) accessibility to the residentially based market
- (iii) accessibility with main pedestrian movements
- (iv) ability to meet costs of specific locations

#### A survey of factors governing the decision to migrate

Further insights into the behavioural aspects of functional location and migration are derived from a survey of commercial establishments in the C.A. The constraints of costs, time and confidentiality associated with obtaining detailed information prevented a full or statistically representative sample of the total population. The survey is described under three procedures: (i) designing a sampling frame (ii) collecting the data (iii) analysing the results.

## (i) Sample frame

Since a full and exhaustive survey was not practicable special care was given to the design of the sample. Two overriding considerations were: (a) that the survey should include a representative proportion of retail, office services and industrial establishments and (b) the survey should include a weighting for those areas of the C.A. in which migration has been a dominant factor of commercial change. No attempt was made, however, to weight the sample with respect to floor space or numbers employed.

The sample points given in Fig. 12 and employed in Chapter 4 were found satisfactory as a starting point. Those points which did not fall on or adjacent to commercial establishments were ignored. Further establishments were added to the sample according to the principles outlined above, with particular weightings given to High Street West, Fawcett Street, John Street, Walworth Way, Market Square and Holmeside.

268 establishments were finally included in the sample, 152 (56.7 per cent) of which were 'retail', 58 (21.6 per cent) were 'service', 46 (17.2 per cent) were 'offices' and 12 (4.5 per cent) 'industrial'. This represented nearly one third of the total commercial population of the C.A.

## (ii) Data collection

The next stage in the survey was to approach the establishments selected by these procedures and collect from each business data and opinions concerning the factors affecting actual or potential migration and location. The nature of the investigation suggested a personal since a detailed questionnaire would prove very long.<sup>(6)</sup> However, separate interviews were ruled out as too time consuming, although occasional supplementary interviews were anticipated.

A short postal questionnaire was designed (Appendix 20) as a compromise between optimum response and maximum detail. It was kept deliberately short (one sheet of A4) and as specific as possible. Some sections (eg. C. were framed as closed questions, others (eg. E.) as open questions to allow fuller expressions of views and perceptions.

The questionnaire was addressed to the manager of the selected establishments in June 1975. Returns were collected after three days of receipt by the writer and a few students. The collection was time consuming. In many cases, it was necessary to call back for the questionnaire. After three unsuccessful visits the respective business was considered uncooperative within the practicable space of time available

and classed as a non-respondent. In other cases, cooperative managers provided further helpful information by offering impromptu interviews.

Generally, the response to the questionnaire was reasonable. 133 replies were eventually analysed, some of which were given begrudgingly, and only after considerable effort expended by the writer, and some of which were returned with positive cooperation. Of the 133 replies, 18 were uncompleted mainly through a refusal to cooperate, rather than being unable to provide the information required. The 138 no returns indicate the disinterest of the respective establishments in academic and non-official research; a few of the nil returns can be attributed to the liquidation of an establishment.

(iii) Analysis of the results

In view of the nature of the survey, the following results must be seen as exploratory and as a basis for more intensive study.

Of the 115 completed (either in part or whole) returns, 9 related to industrial establishments, 23 (20% to offices, 25 (21.8%) to services and 52 (45.2%) to retail establishments, (6 were unclassified). The composition of the respondents reflected the composition of the total population. (see Table 19)

Of the respondents who completed Section A, 45 per cent had occupied their premises for only 1-5 years and 22% for 6-10 years. The remainder were almost equally shared between the other three time categories. The turnover of commercial establishments was high but not surprisingly so. These results confirm the conclusions reached in Chapter 6 based on telephone directories that commercial establishments are on average, very young in the C.A.

Table 19: Composition of respondents

Nature of Business	Number	Per Cent
<u>Retailing:</u>		
- Food Shops	6	5.2
- Shoe Shops	5	4.3
- Clothes Shops (Incl. tailors)	16	13.9
- Household Goods	4	3.5
- Furniture Stores	4	3.5
- Department Stores	3	2.6
- Stationers	4	3.5
- Antiques/Jewellers	2	1.7
- Miscellaneous	8	7.0
<u>Total</u>	52	45.2
<u>Offices:</u>		
- Building Society	8	7.0
- Financial Consultants	6	5.2
- Insurance	3	2.6
- Solicitors	5	4.3
- Estate Agents	1	0.9
<u>Total</u>	23	20.0
<u>Services:</u>		
- Health (Chiropodist/Optician)	2	1.7
- Hairdresser	3	2.6
- Agencies (incl. travel)	5	4.3
- Rental Services	4	3.5
- Laundry	2	1.7
- Entertainment/Eating	2	1.7
- Other Miscellaneous	7	6.2
<u>Total</u>	25	21.8
<u>Industry:</u>		
- Tailor	1	0.9
- Printer	1	0.9
- Bakery	1	0.9
- Clock Repairs	2	1.7
- Car Repares	2	1.7
- Other	2	1.7
<u>Total</u>	9	7.8
	<u>Unidentified</u>	5.2
	<u>Grand Total</u>	115
		100.0

Data on the migratory origin of establishments are too fragmentary for detailed comment. However, they do confirm the general findings of the directory survey given in the previous chapter. About half (51.3%) of the respondents had moved into their premises from elsewhere in Sunderland. Most of these involved a short move from one part of the central area to another part, and features of this functional migratory process have already been summarised. An important minority of the respondents, however, had moved into the C.A. from suburban streets and centres. Again, they were often small establishments and involved with miscellaneous activities of which 'services' were the most common. They had been business successes <sup>(18)</sup> in their original location and had decided to move up the hierarchy into the commercial core of the town where competition and market potential were higher. Because of their lower capital reserves and the smaller scale of operations, these establishments usually located in off-centre streets. Frederick, Norfolk and Olive Streets are good examples in central Sunderland.

The remainder of the respondents in Section B (48.7 per cent) represented two main categories of establishments: those which were new branches of existing firms; those which were long stayers in their present premises. The former group is of more interest here. Branch firms have been important in-migrants to the C.A., particularly with the construction of the new shopping precinct. These establishments, therefore, are dominantly retail or retail/service. Furthermore, they are linked with other branch establishments of their parent firm in other towns in the North East, especially Newcastle and Middlesbrough. Rarely\* have the branch firms been associated with towns outside the North East and with non-retail firms.

59 of the respondents did not complete Section C either because the questions were not applicable or because the answers were not available. The results of the 56 replies are summarised in Table 21. Most respondents indicated the importance of several factors: the total, therefore, exceeds the actual number of returns. It shows the relative frequencies of the mentions of each of the ten factors. It can be seen that the overriding factor was the need for more space. Conversely, high rents and rates were not considered important or even relevant. <sup>(19)</sup> The importance of the other factors varied between these two ranges with accessibility to clients, and a good 'environment' being placed more highly than nearness to transport and age of building.

\*Exceptions are provided by one Bank, two Building Societies and one Industrial concern all, of which were associated with West Riding towns.

Table 20: Reason for Migration		No.	Percentage
(i)	Building too small	26	27.9
(ii)	Building too old	8	8.6
(iii)	Poor accessibility from clients	17	18.2
(iv)	Rents and rates too high	2	2.2
(v)	Compulsory order on premises	6	6.4
(vi)	Isolated from transport/communication	5	5.4
(vii)	Isolated from business contacts	9	9.7
(viii)	Too far from place of residence for employees	0	0.0
(IX)	Premises in a 'poor area' environmentally	10	10.8
(X)	Other reasons	10	10.8
Total		93	100

The returns relating to Section C were subdivided into two groups: those returns which listed two or more factors. The purpose of this was: (a) to throw more light on the relative importance of the factors; and (b) to identify associations between the factors.

34 returns out of 57 chose to identify only one factor which caused their commercial establishment to move. These returns are summarised in

Table 21: Reason for Migration		No.	Percentage
(i)	Building too small	12	35.3
(ii)	Building too old	1	2.9
(iii)	Poor accessibility from your clients	2	5.9
(iv)	Rents and rates too high	0	0.0
(v)	Compulsory order on premises	6	17.7
(vi)	Isolated from transport/communications	0	0.0
(vii)	Isolated from business contacts	3	8.8
(viii)	Too far from place of residence for employees	0	0.0
(ix)	Premises in a 'poor area' environmentally	2	5.9
(x)	Other reason (specify, if possible)	8	23.5
Total		34	100.0

Table 22. The dominant position of size of accommodation is confirmed.

Of the others, a compulsory order on premises was the next most frequently isolated factor. Age of building, rents and rates and accessibility to transport were not, by themselves, considered sufficiently important to migrate. The miscellaneous collection of factors under 'other reasons' (Part x) includes mention of tenure, broken partnerships, etc.

The remaining 20 returns suggested that the decision to migrate had been taken for a combination of reasons, rather than any one single reason. Four pairs of factors occurred most frequently:-

- (a) Building too small<sup>(i)</sup> and poor accessibility from clients.<sup>(iii)</sup>
- (b) Building too old<sup>(ii)</sup> and building too small.<sup>(i)</sup>
- (c) Poor accessibility from clients<sup>(iii)</sup> and premises in a 'poor area' environmentally.<sup>(ix)</sup>
- (d) Premises in a 'poor area' environmentally<sup>(ix)</sup> and isolation from business contacts.<sup>(vii)</sup>

The inter and intra-linkages between these pairs of factors can be explained by spatial location. The replies were associated with establishments in non-central streets. Here buildings are old (see Fig.16), are often occupied by multiple uses, have a deversified and miscellaneous commercial structure and are isolated from the centre of commercial activity in the C.A.

There is no apparent functional differentiation between establishments, stressing the need for space, 'good' locations and access with clients. The conclusion to be drawn, from these replies and confirmed by findings described below, is that the perception of the commercial potential of central Sunderland by managers /directors of differing remarkably coincident.

The towns system of commercial establishments is a facet of C.A. change which is not well developed in geographical work. There was some evidence that the expected relationship between type of function and tenure system applied. Of the 112 returns answering Section D. of the questionnaire, 32 (28.6 per cent) were over occupied, 36 (32.1 per cent) were rented, 29 (25.9 per cent) were long leasehold and 15 (13.4 per cent) were short leasehold. Owner occupied and long leaseholders were the most stable establishments with their businesses operating for more than six years from the same location. Although they represented a wide range of commercial activity, they tended to be the larger and better known businesses.

Finally, the invited responses expressing the perceptions of

individual managers about particular locations proved instructive. It is, of course, difficult to express the intensity of feeling of individual replies and to be absolutely sure that the interpretations offered are what was intended, 76 returns were received which offered general and specific information on the attitudes of individuals and their firms to the locational attributes of their premises. The nature of these attitudes can be organised under four headings which succinctly express the basic principles. These are (i) the distance principle, (ii) the movement principle, (iii) the economic principle, (iv) the environmental principle.

#### The role of distance

Most of the returns highlight this principle in a variety of contexts: firstly, distance from peak pedestrian flows was stressed by retail and service establishments, in particular. Building societies and some insurance establishments were the only two 'office' activities which indicated their interest in this factor. Commercial fortunes for these groups, in the eyes of the respondents, clearly declined with increasing distance from peak pedestrian flow.

Secondly, distance from transport terminals and car-parks was acknowledged by a wide range of retailers and 'service' activities. Bus and rail termini and car parks were seen as the generators of customers and as inputs points of the C.A. pedestrian system. For example, one manager of a furniture store attributed the trade he attracted from the villages of Durham to his location near the Park Lane bus terminal.

Thirdly, distance from other controlling 'nodes', apart, from transport and parking 'nodes' were considered by respondents as important controls. In particular, the G.P.O., Gas showrooms, Civic Centre and major Department Stores were singled out as additional generators of pedestrian activity. Locations near them were considered 'good' ones. The relocation of the G.P.O. from West Sunnyside to Market Square in 1970. which robbed the former peripheral street of much needed pedestrian activity, was specifically mentioned on a number of occasions. Another example of a node in the office sector was provided by the County Courts which are, according to one respondent, a locational influence on the siting of solicitors.

Fourthly, distance from the town centre, a factor closely related to the first point above, was highlighted by several respondents on account

of its shifting nature. One retail establishment in Fawcett Street referred to its commercial environment as 'ghost-like' now that the new precinct was operational. Another office establishment had located in John Street in 1965 and then found that the shift in the 'town centre' had placed it at a locational disadvantage in 1975.

Fifthly, distance from other establishments in the same activity was considered important by respondents in different ways. To most retailers, proximity to other outlets of the same type was viewed as a locational advantage. To one solicitor, however, being in a street with no other competitors was an advantage.

### The role of movement

A C.A. as a dynamic entity depends on movement in two and three dimensions. The recognition of the value of movement in commercial contexts was implicit in many returns.

Firstly, the route by which vehicular traffic were channelled around and through were considered vital to some establishments. Service outlets and retail outlets suffered by the one-way system, although several returns recognised that a one way flow may be a locational advantage in certain specific sites. At the micro level, one respondent claimed his retail establishment was disadvantaged by the location of traffic lights which by stopping traffic enable some properties to be more conspicuous than others.

Secondly, most returns confirmed the expected response underlying the importance of pedestrian traffic. Evidence was also provided that managers take note of the micro level of movement.<sup>(21)</sup> One retail manager recognising the disadvantages of a quieter part of a street, and another observing that different sides of the same street sometimes have contrasting commercial potential. One department store manager found that safety rails interfered with the natural advantages of his premises by preventing free pedestrian flow. In pedestrianised shopping areas, parking has to be accommodated in centralised facilities. Much of the C.A., away from the pedestrianised areas of the town centre, has a restriction on street parking. Frederick Street, Foyle Street, Norfolk Street and West Sunnyside, however, all possess a significant advantage over other streets, according to many respondents, solicitors, small service establishments, certain workshops and general offices in particular subscribed to this view.

### The role of economics

The ability to meet rents and rates in a well developed theme in urban dynamics. It was expressed by those respondents who claimed that costs of accommodation were significant locational consideration. Whilst rates and rents were not important factors in the decision to relocate, they are consciously considered by many small scale operators where, relatively, they assume greater importance compared with total costs. There is evidence that some managers of 'service' establishments are prepared to trade off a 'poorer' location for cheaper rates and rents.

### The role of environment

Lack of noise, pollution, vandalism and congestion, a 'pleasant' environment and a 'prestigious' property, were mentioned by several office and service managers and even one manager of an industrial establishment as factors they considered in their present location. 'Office' managers were particularly perceptive of the architectural condition and style of buildings, and support landscape/conservation schemes more than their counterparts in 'Service' or 'industry'.

The conclusion to be drawn from the survey are two fold: (a) that perception of individual firms does vary and affect the nature and degree of commercial mobility in a C.A. and, (b) that actual behaviour patterns support a number of theoretical principles.

Anomolies and exceptions are provided by individual cases where some or all of expected patterns are not followed. The particular commercial behaviour of individual firms in a little developed aspect of geographical literature.<sup>(22)</sup> The business history and locational strategy of two establishments with a long association with central Sunderland are now considered as case studies.

### Locational strategies of two individual establishments

Vaux and Binns are, respectively, large scale manufacturing and retailing concerns both with a long association with central Sunderland. One would expect, therefore, that their separate business histories would reflect the changing commercial environment of the C.A., and, in turn, due to their size and status, it may be expected that they have helped to shape in some way, the internal structure of the evolving C.A. These two hypothesis are now examined in more detail.

Both Vaux and Binns are large and stable commercial establishments. The spatial implications of this fact are twofold; (a) they serve as 'lead' firms <sup>(23)</sup> generating and attracting further commercial trade, and (b) they serve as 'anchors' in a changing central area environment to act as focal points for trade. Such firms usually possess considerable investment funds, reasonably advanced technology, administrative expertise and entrepreneurial skills. These strengths enable them to combat the local and temporary changes which affect smaller businesses in central areas, and, indeed, even to ignore longer term trends. They possess output structures of greater spatial dispersal and have greater spatial range than smaller and less productive operations. And they are able to maintain their growth policies during periods of national and regional recession by relying on their more complex and dispersed linkages. <sup>(24)</sup> Also, large firms are often expansionist in terms of their spatial behaviour and may enjoy considerable lobbying power to modify or change local planning decisions.

The role of individual 'lead' firms in C.A. change involves a micro-study in which processes and features peculiar to one firm are investigated. Recent investigations by Moseley and Townroe, and Taylor and Wood <sup>(25)</sup> confirm the value of such micro analysis although their work relates more specifically to industrial linkages.

#### (i) Vaux Brewery

Vaux Brewery is by far the largest industrial concern in the study area. Although not located in the delimited commercial core of Sunderland, the industrial complex occupies an extensive area in the north-west corner of the grid system shown in Fig.11. The spatial growth of the brewery has been a positive barrier to central area growth in that direction.

The examination of the spatial behaviour of Vaux in the context of the changing dynamics of the C.A. is justified in three respects: firstly, it demonstrates how a major expanding firm reorganises itself spatially in a changing urban environment. Secondly, it throws more light on the mechanics of the accretion process at the level of the individual firm. Thirdly, it is a firm with a continuous business history over more than 100 years in or near central Sunderland.

Vaux moved to its present Castle Street location in 1875 from Union Street where it had existed for thirty years. <sup>(26)</sup> The decision to migrate was forced by the penetration of the railway into central Sunderland causing the demolition of buildings in Union Street. The new location provided a largely undeveloped site for expansion which

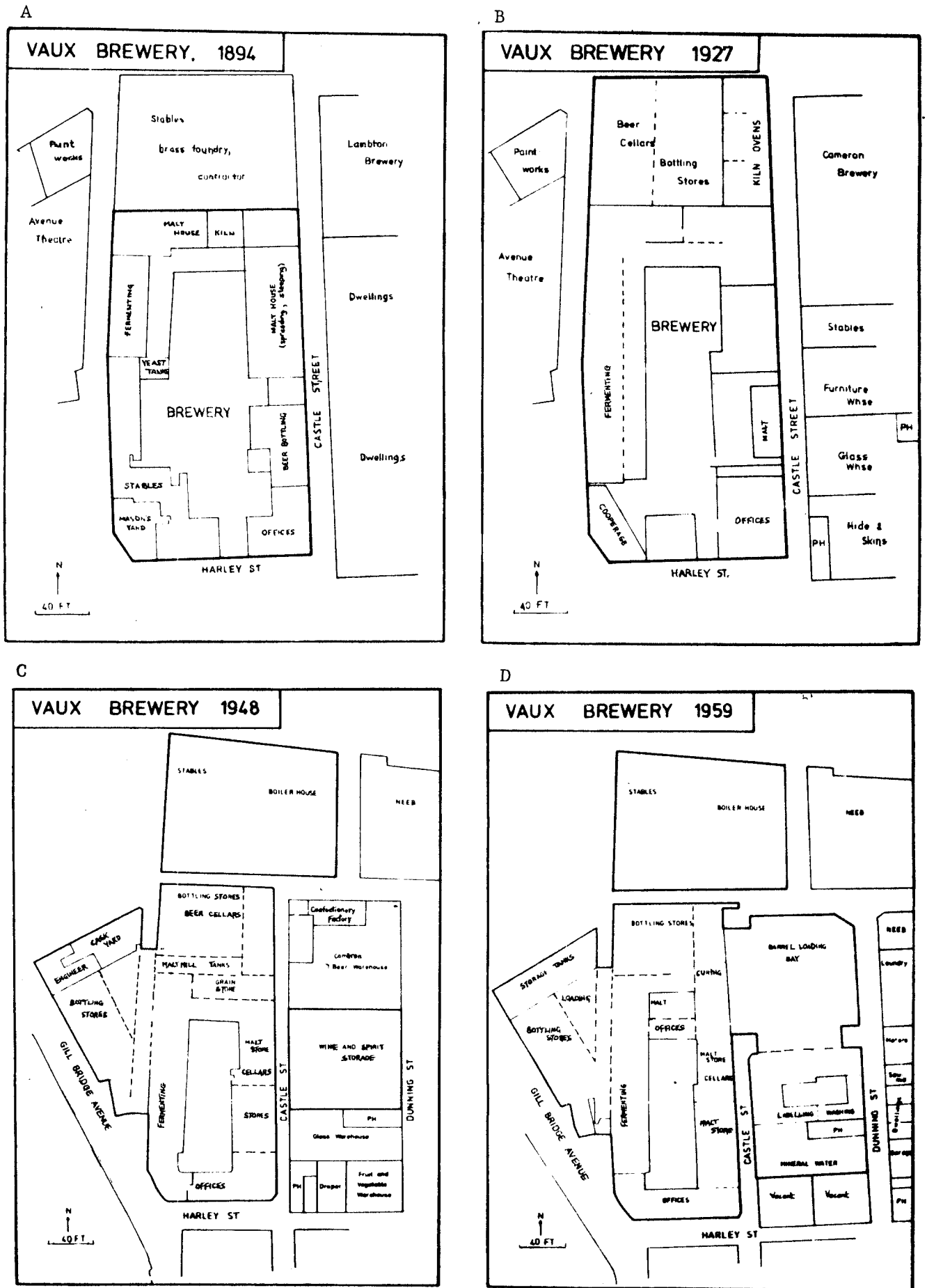

Fig. 38. The spatial history of Vaux Brewery.

can be traced fairly precisely from insurance maps, written sources and information provided by Vaux. (Fig.38

The phases of growth partially reflect changes in the brewing industry.<sup>(27)</sup> By 1894, the Vaux brewery had emerged from a small Victorial brewery into a modern style industrial complex. Two thirds of the block enclosed by Castle Street. Harley Street and Gillbridge had been enveloped by the expansion of the brewery northwards from its original nucleus and frontage. It was surrounded by low quality dwellings with rateable values averaging only £12.50,<sup>(28)</sup> industrial workshops to the north in the direction of the river and a theatre to the west. The whole site of the brewery extended over two acres - considerably larger than the original core. The accretion reflected a progressive and expansionist management. The firm was innovatory and technologically advanced: it was the first brewery in England to include new patent pneumatic malting drums. By 1900 it employed two hundred workers. There was pressure for more space to accommodate storage facilities and bottling departments. And the Sunderland complex became the base for extending ownerships over smaller breweries at Spennymoor, Newcastle upon Tyne, Middlesbrough, Alnwick, Leeds, Glasgow and Aberdeen. The growth of Vaux had two components then: an internal component spatially extending outwards from the Castle Street nucleus and an external component as part of a chain of breweries in other parts of England and Scotland.

Fig.38 (B) maps the age of accretion away from Harley Street in 1927. New bottling and storage facilities had been accommodated in the space vacated by the closure of a foundry. The general declining status of the surrounding area can be observed from the conversion of residential properties in Dunning Street into warehousing and miscellaneous uses. At the north end of Dunning Street, the small Lambton brewery had been bought over by Camerons; later it was to be used only as a warehouse.

The inter-war period introduced a burst of expansion in all directions (Fig.38 C). The theatre in Gill Bridge Avenue was physically developed and incorporated into the complex. Accretion northward took Vaux beyond Matlock Street into empty properties to the north and to the east in Dunning Street into former furniture warehouse accommodation. An interesting development was the initiation of a policy of buying up cottages in the residential streets north-west of the brewery for worker accommodation. The spatial extent of the complex in 1959 is shown in Fig.38 (D). Cameron's warehouse had been taken over and incorporated in Vaux. Dunning and Queen Streets housed mixed residential, commercial and industrial properties, properties which were ripe for inclusion in

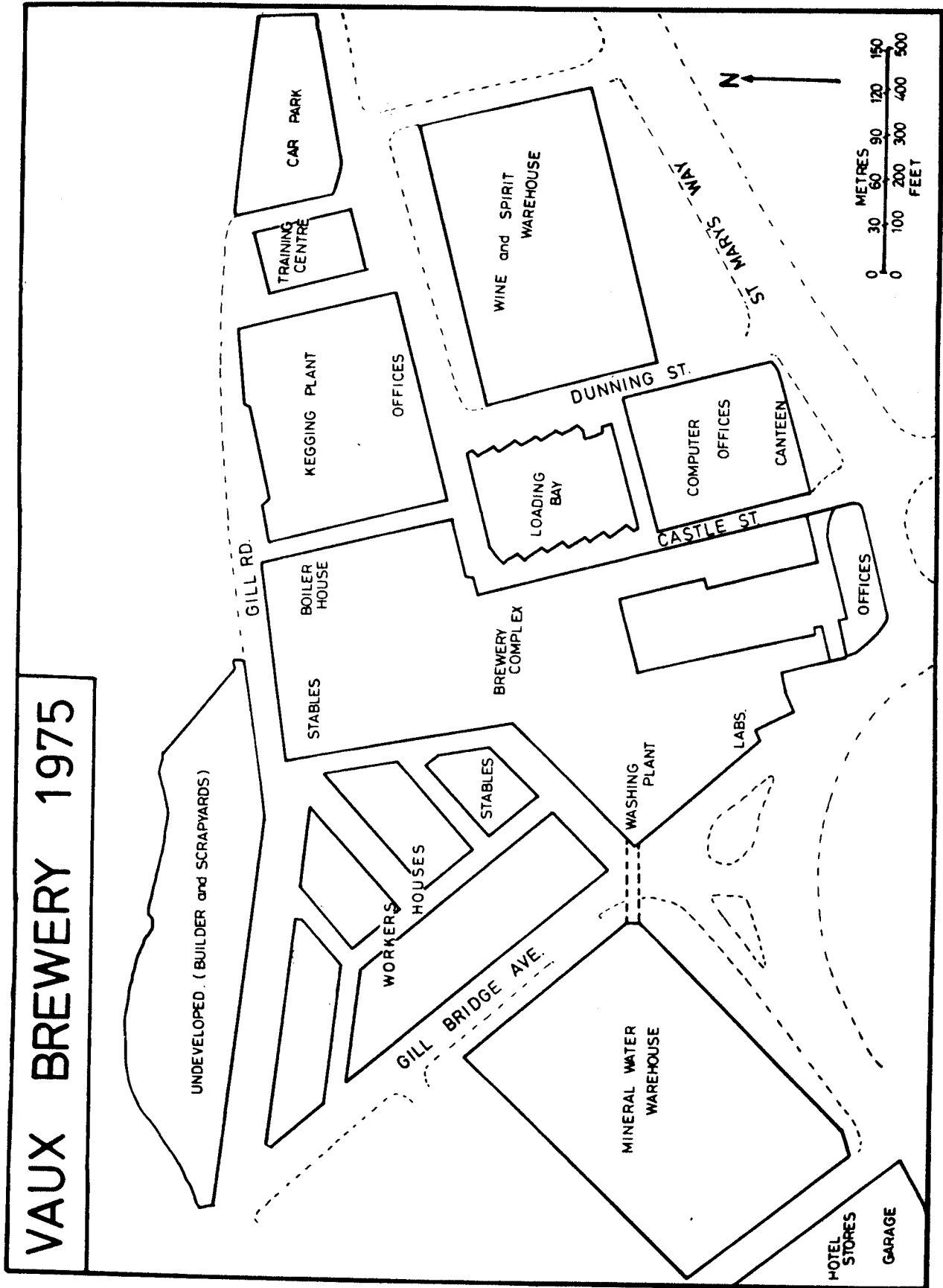

# VAUX BREWERY 1975

Fig. 39. Vaux Brewery, 1975.

the expansion strategies of Vaux. Other properties were empty in anticipation of the construction of St. Mary's Way, an inner ring-road. This truncated the southern parts of the above named streets and effectively prevented Vaux spreading in that direction.

In the recent period (1959-1976), Vaux both internally reorganised and extended to accommodate new facilities and externally expanded interests in other parts of the country; the culmination of this outward going policy was the acquisition of a small brewery near Brussels in 1974. Fig.39 shows the internal extent and structure of the brewery in 1975. The congested handling problems in the old brewery precinct created by the upsurge in soft drink sales generated the need for more space. More intensive use was made in the old brewery nucleus with computer installations and office renovations. The former N.E.E.B. plant vacated by their migration to a site on the periphery of Sunderland was developed as a kegging plant. A new warehouse to the west of the brewery was completed in 1970 to house the soft drink products. How spatially demanding the modern brewery industry was becoming can be judged by the fact that the new warehouse covered an area as great as the 1894 brewery. Furthermore, unanticipated growth created the need for another equally large warehouse for the storage and handling of wines and spirits. The only suitable and available space was to the east beyond Dunning Street; and the building has now (1976) been completed.

The acquisition of scrapyards, and builder yards to the north between Gill Road and the river cliffs means that further spatial expansion and internal reorganisation are possible, if and when pressure and congestion build up again. The location of the brewery in the frame of central Sunderland meant that the adjoining properties were occupied by a miscellaneous collection of other businesses. These were characterised by short lives, small size and precarious existences. They were attracted, and existed there by the exodus of the residential population, the deterioration of the environmental quality, the aging and obsolescence of the structures, and the low rates and rents. They were often able to pursue their lines of business without the expense of structural changes; the capital outlays were often small.

By comparison, the expansion of Vaux was well financed and the result of an on-going policy of spatial expansion. Whenever adjoining properties became available either through liquidation or relocation, they were bought up by Vaux. As a result, the accretion process can be described as piecemeal. It is also true to say that accretion was restricted in some directions by various physical and human barriers.

The inner ring road, for example, truncated possible spread southwards; the gorge-like river banks to the north; and the stable and established Police Headquarters to the west.

A key factor revealed by investigation into this illuminating case of commercial change was the contrast in the management of Vaux with that in the smaller adjoining businesses. The latter concerns, with diverse and transient owners, leaseholders and tenants were unable to compete with the stable continuous family firm of Vaux in which decisions were taken by virtually one man over many years. The peculiar brand of personalised decision-making exercised in Vaux and the autocratic management structure which supports it are features which are difficult to include in general theories on the spatial behaviour of firms.

#### (ii) Binns Department Store

Binns provides similar insights into the spatial behaviour of firms in central areas, but from the viewpoint of retailing. Binns, like Vaux, has been a continuously successful firm, having its origins in Sunderland but spreading into other towns in England and Scotland. Its birth, relocation and expansion on its present site enables interesting spatial parallels to be made with Vaux. Unlike Vaux, however, its business is dependent on pedestrian shoppers and on the structure of the retail trade.

Binns drapery business was born in 1783 and located in High Street West, Sunderland. In terms of shopping potential, this site was ideal. It was on the main thoroughfare of old Sunderland; it was located on the west side of the old town in the direction of the spread of population, and it was close to the high class residential streets of Villiers and Nile Streets. It was also furthest from the warehousing, industrial and densely inhabited tenement areas of the east end of the town. The decision to locate the new business in High Street seems to have been reached by Mr. G. Binns, a Quaker and progressive business man.

The business operated from this address for over 100 years, during which time, the High Street experienced a westward shift of commercial activity outlined in Chapter 3. The ageing of the property, the declining business fortunes and decreasing fashionability persuaded G. Binns grandson, Joseph to relocate. His choice was a former residential property at No. 46, Fawcett Street.

The decision to relocate at this address in the most fashionable of Sunderland's central streets reflects the trends of the time. Fawcett Street had begun to be invaded by commercial enterprises in the last

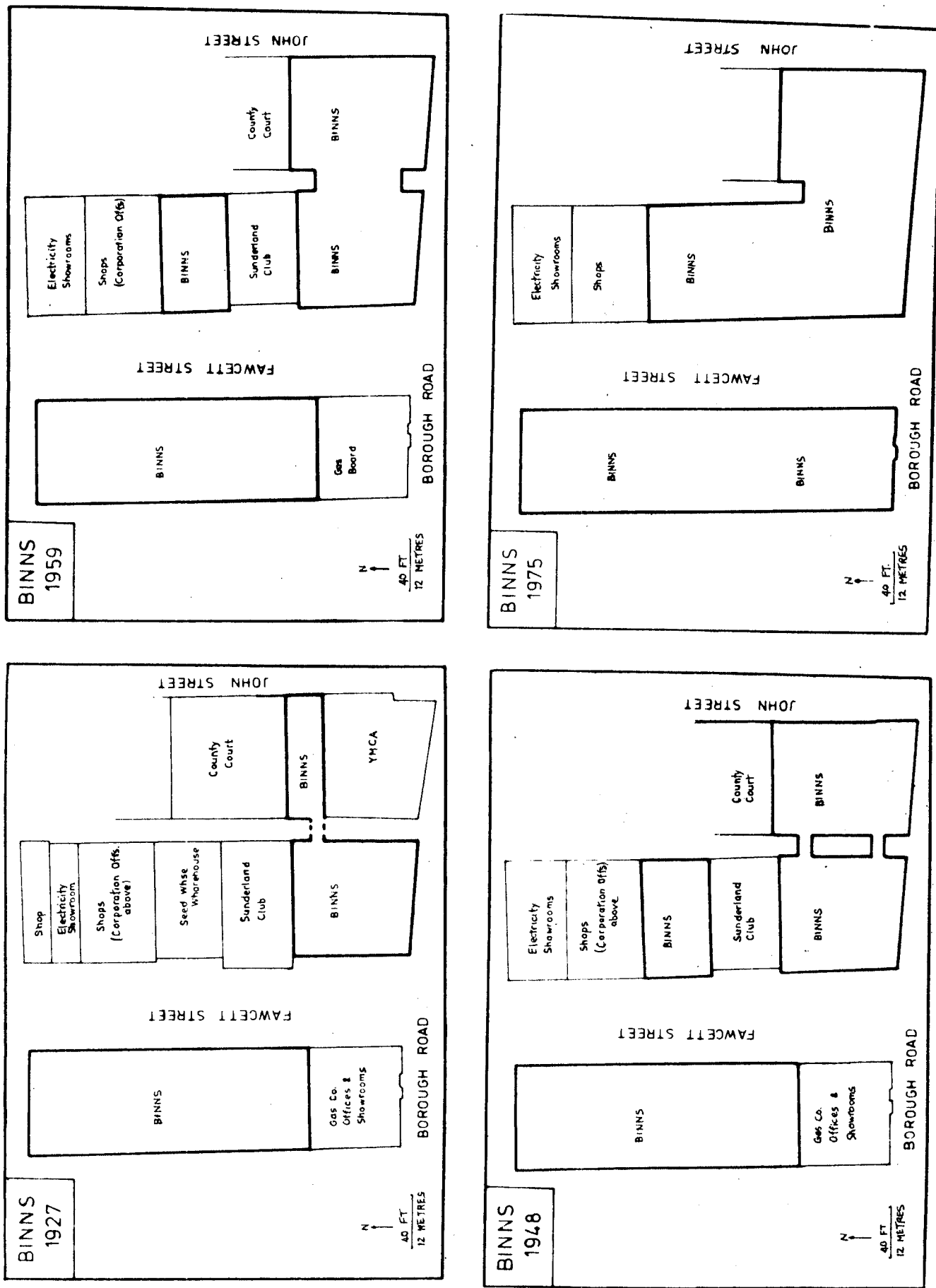

Fig. 40. The spatial history of Binns, 1827-1975.

quarter of the nineteenth century based on its increasing accessibility and potential for business (See Chapter 3). In 1876, the penetration of the railway south of the Wear into central Sunderland and the construction of the terminal at Union Street immediately behind Fawcett Street caused marked commercial repercussions. Demand for commercial properties close to peak pedestrian activity meant that Fawcett Street, in particular offered attracted business locations. Only the larger and more successful commercial enterprises could afford these prestigious sites.

The success of the Binns business in Fawcett Street generated pressures for expansion and internal reorganisation. The converted residential structure of No. 49, with a shop frontage at ground floor level only, soon proved inadequate to meet business growth. Its transformation from this original state to its present position as a 'lead' and 'anchor' establishment in the C.A. was achieved progressively but marked by distinct developments.

Firstly, Binns became a Limited Company in which customers were invited to take up £6,000 of the £10,000 capital. Secondly, in 1906-1907 the premises in Fawcett Street were remodelled on American retail patterns. Thirdly, a policy of spatial expansion was commenced by which adjoining properties were taken over. These not only increased the areal extent of Binns but also diversified the range of sales. Fourthly, innovative and widespread advertising were adopted in the 1920's as deliberate policy to expand commercial business in the depression years. Fifthly, in the inter-war years, the Sunderland base was the platform for extension of the business into a number of other cities and towns: between 1922 and 1934, Binns, Fawcett Street, became the headquarters of a group of nine stores in other English and Scottish towns. Meanwhile, the Fawcett Street site was continually expanded into adjoining properties. Whenever they became available, the spatial growth has been mapped in stages in Fig. 40.

An ambitious component of this growth was the leap-frogging from one side of Fawcett Street to the other and the linking of the two by a private pedestrian underpass. The whole store was further remodelled and rebuilt as a five storey department store in 1953, thus confirming its stature in the retailing of central Sunderland. In the same year, the family tradition of the Company was lost when the Binns became part of the House of Fraser. Unlike Vaux, therefore, the fortunes of the company have become in part at least, dependent on external management and outside influences.

Despite these organisational and structural changes, however, the locational strategy of Binns has remained unchanged. The construction of the recent new shopping centre, which has contributed to the shift of the centre of retailing away from the traditional shopping streets of High Street West and Fawcett Street into the precinct, provided Binns the opportunity to reappraise its locational strategies.

The decision whether to relocate in view of the changing patterns or to remain in the existing premises was, it appears taken quickly and without much debate. The Board of Directors rejected the relocation strategy for several reasons. In the first place, it was felt by the Directors that the present Binns store was so close to the new centre that relocation was unnecessary. The floor space required to accommodate Binns was not available in the new centre in any case. Moreover, Binns felt they had a well established clientele at their existing location which was viewed by shoppers as a major foci of consumer activity. Although the pull of Fawcett Street for shopping has declined relatively, the present location is close to railway terminal, bus stops and taxi ranks; and Fawcett Street is still the major banking centre.

The confidence in the existing location in fact was demonstrated by incorporating the adjacent and recently vacated gas showrooms into Binns. The spatial growth of Binns on the west-side of Fawcett Street, in fact now seems complete with full occupation from No. 38 to 48.

Barriers to further growth exist as in the case of Vaux. Roads are an inconvenience since they fragment the store; on the other hand, there is no fundamental reason why Binns cannot occupy more space across existing roads if sites are available (eg. old Town Hall site). The railway provides a more serious barrier to growth on the west. And to the south, stable civic institutional buildings, eg. Museum/library prevent expansion in that direction. The declining pedestrian activity acts as a disincentive to commercial growth eastwards. The most natural zone for possible further expansion lies northwards between Nos. 27 and 29(inclusive) whenever their occupant businesses relocate or are liquidated.<sup>(30)</sup>

#### Some spatial parallels of Vaux and Binns

Geographical literature on the locational strategies of individual firms in central areas is scantily developed. Practical difficulties are obvious and were experienced in the present work: Board room minutes are often not released, turnover sales and profit return are not revealed and key individuals are not available.

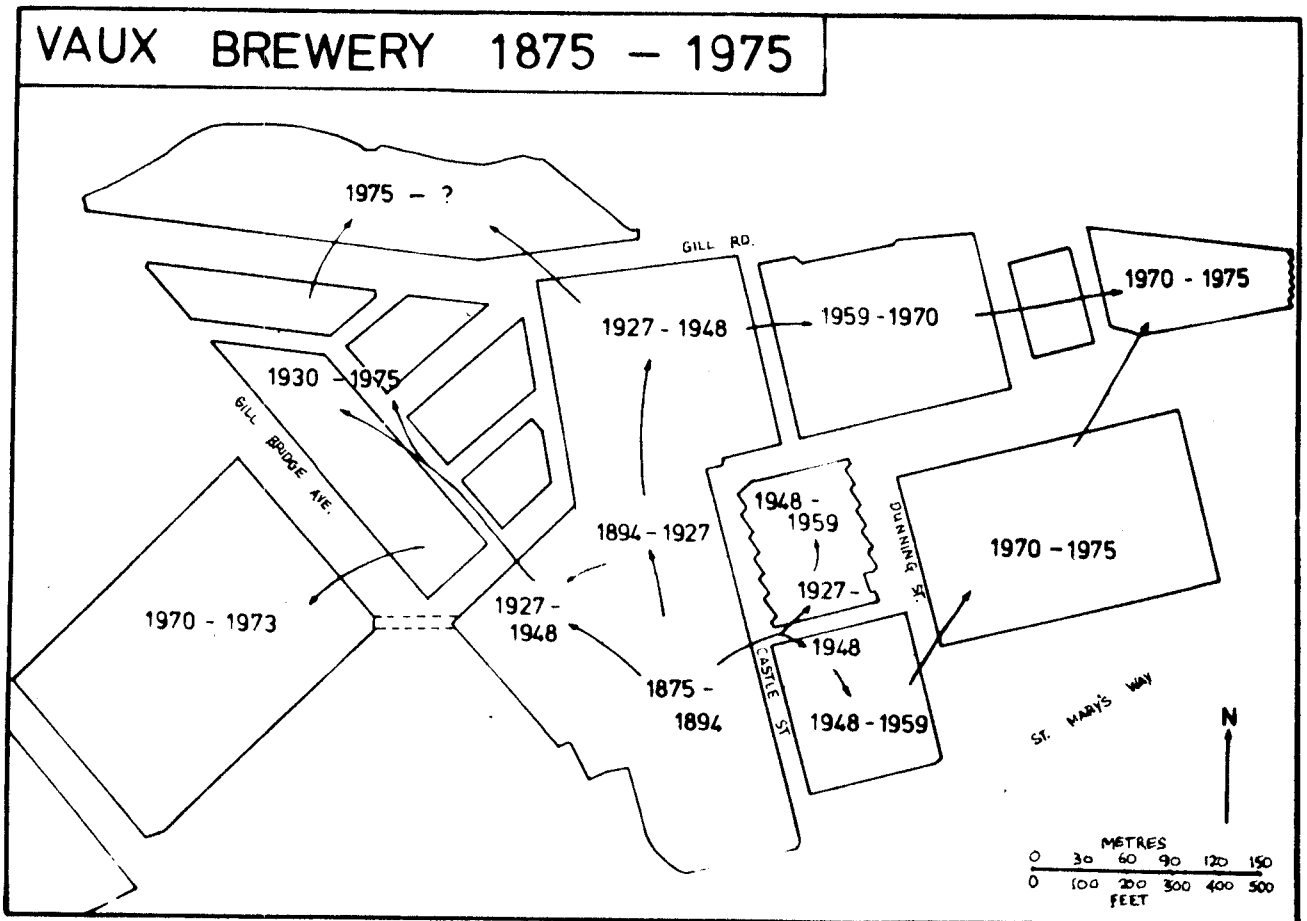
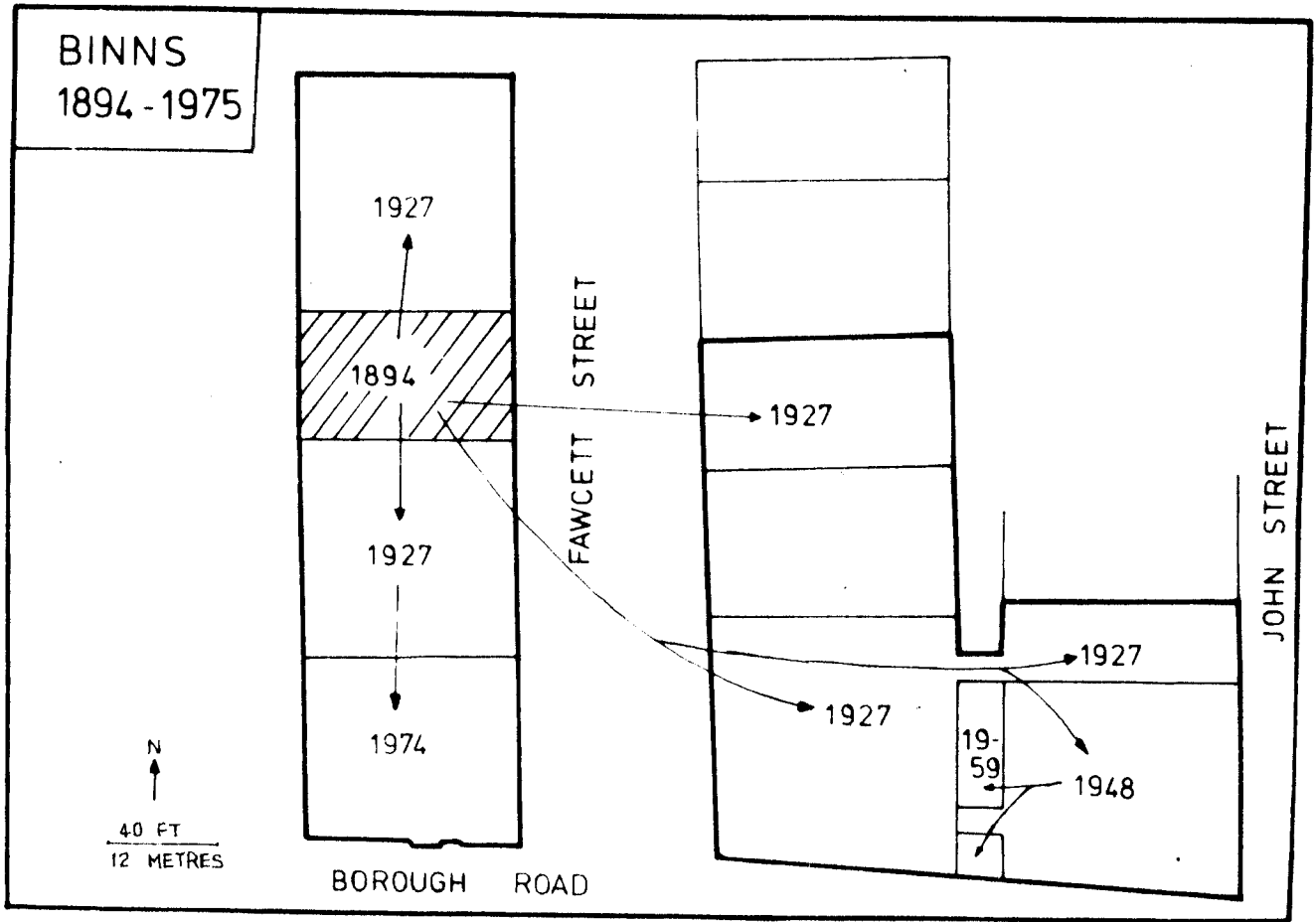

Fig. 41. The accretion process of Vaux and Binns, 1894-1975.

However, interesting and relevant work related to the spatial history of major firms in C.A. research can be done.<sup>(27)</sup> The cursory examination of Vaux and Binns suggests that external C.A. change and internal reorganisation may be closely linked and that spatial policies may be very similar.

Fig. 41 portrays the spatial growth of the two firms. Both firms relocated from their original birth place due to powerful and dynamic influences. Their second location was chosen to suit respective commercial needs and provided the site for their spatial growth over the ensuing years. Both firms made innumerable decisions to expand into adjoining properties, to remodel adjoining properties and to demolish and construct new purpose built structures in that chronological order. These adjoining properties were occupied by diverse users and owners and by small transient operators. The financing of this spatial growth was backed by large funds generated by a successful, progressive and family-based management. In both Vaux and Binns, this intra-central area growth was complemented by expansion and the establishment of branch firms in other towns and cities in England and Scotland. The expansion of both firms is still a feature of the contemporary period although restricting barriers are becoming more significant as the sites are further developed; in both cases spatial growth is effectively restricted to only one direction. The perceptions of the commercial environment of central Sunderland by the decision-makers in both firms tend to suggest that they exploit developing opportunities as and when they occur, rather than actively engineering them. Finally, there is a strong built-in inertia to relocation due to the heavy investment already made and the traditional clientele which is firmly established. The parallels of these two micro studies suggest the need for more explicit treatment of: (i) the impact of C.A. change mechanisms on firms. (ii) the role of management decisions in the spatial behaviour of firms, (iii) the symbiotic relationships between 'lead' firms and central areas.

Summary

The spatial behaviour and locational strategies of selected urban activities in central Sunderland follows expected patterns. Examples of clustering and dispersion show that functions perceive C.A. environments differently. A survey of individual commercial establishments permitted weightings to be given to various factors influencing the decision to migrate. The business history of two 'lead' firms in the C.A. revealed several spatial parallels.

References and end notes

- (1) Rogers, A. (1969), Quadrat analysis of urban dispersion (a): case studies of urban retail systems: Environment and Planning, Vol. 1, p.156. The Consumer includes consideration of the distribution of population, income and purchasing power; the 'urban system', includes accessibility, site economics, advantageous, location, etc., and the 'establishment' refers to specific needs and structure.
- (2) Nelson R.L. (1958), The selection of retail locations, p.43-78, and Lee, Y. (1974), 'An analysis of spatial mobility of urban activities in downtown Denver'. Annals of the Regional Science, Vol. 8, pp. 95-108.
- (3) See Harvey, D.W. (1968), 'Pattern, process and the scale problem in geographical research', Transactions. Institute of British Geographer, Idem. (1966) pp. 71-78: 'Geographical processes and the analysis of point patterns.' Transactions, Institute of British Geographers, No. 40, pp.81-95.
- (4) This statistic is found in numerous geographical articles, eg. King, L.J. (1969). 'The analysis of spatial form and its relation to geographic theory', Annals of the Association of American Geographers, Vol. 59, p.576; Bachi, R. (1976). 'Geostatistical analysis of internal migrations', Journal of Regional Science, Vol. 16, No. 1, pp.1-19.
- (5) A good example from the British literature is provided by Hughes.
- (6) Dacey, M.F. (1972), 'An explanation for the observed dispersion of retail establishments in urban areas', Environment and Planning, Vol. 4, pp. 323-330; Rogers, A. (1969), 'Quadrat analysis of urban dispersion (1)', Environment and Planning, Vol. 1, pp. 47-80, Rogers, A., (1969), op.cit.
- (7) Getis, A. (1964), 'Temporal land use pattern analysis with the use of nearest neighbour and quadrat methods,' Annals of the Association of American Geographers, Vol. 54, pp. 391-399. Getis's data were for Lansing, Michigan, USA for 1900-1960.
- (8) Sherwood, K.B., (1970), 'Some applications of the nearest neighbour technique to the study of the movement of intra-urban functions.' Tijdschrift voor Economische en Sociale Geografie, Vol. 61, pp.41-48. Sherwood's data were for Shrewsbury, England for 1880-1962.
- (9) A comment by Dacey, M.F. (1972), op.cit. is worthy of note in this respect: "it is a frequent practice to exclude the commercial core from studies of objects in urban areas." (p.323).
- (10) Unlike for Kingston upon Hull: Wild, M.T. and Shaw, G. (1974), 'Locational behaviour of urban retailing during the nineteenth century: the example of Kingston upon Hull Transactions and Papers, Institute of British Geographers, p.102
- (11) Solicitors, for example may belong to syndicates in which 6 or 7 individual solicitors practice in as many different rooms in one or more properties. They often appear, however, only as one point in the analysis. To give them a realistic and proper weighting involves a lengthy, laborious field operation, often impinging on confidentiality.

- (12) Figures were provided by the Planning Department, Borough of Sunderland.
- (13) As enumerated by Mr. D. Hodgson, Manager of Yorkshire Bank, 1970-74.
- (14) Private conversations with Messrs. I. Arnott and C.J. Bentley, Insurance Brokers of the Midland Bank Chambers and 17 Foyle Street, respectively.
- (15) Adapted from the Survey of Office Location (Economic Unit, 1964).
- (16) For a discussion of questionnaire versus interview in geographical work see Townroe, P.M., (1971), 'Industrial location decisions: a study in management behaviour'. Centre of Urban and Regional Studies, University of Birmingham, Occasional Paper No. 15, Chapter 3, p.28 et.seq.
- (17) In some cases, junior staff were delegated to complete the form.
- (18) eg. Photographers and agencies operating from a home (residential) address.
- (19) A finding confirmed also in a Survey of Office Locations, (1964), Table 5.9, p. xiii.
- (20) Berry, B.J.L., and Parsons, S.J. and Platt, R.H., (1968), 'The impact of urban renewal on small business: the Hyde Park - Kenwood case', Centre for Urban Studies, University of Chicago, is an exception.
- (21) For an interesting and relevant contribution on micro movement, see: Hurst, M.E. Eliot, (1974), 'Micromovement and the urban dweller', Selection 29 in Transportation Geography: comments and readings pp. 482-509.
- (22) A more general study of pedestrian flows in a central area is provided by: Lewis, G.J. (1974), 'Pedestrian flows in the central area of Leicester: a study in spatial behaviour'. East Midlands Geographer, Vol.6, Pt. 2, No. 42, Dec. pp. 79-91.
- (23) A 'lead' firm exerts considerable growth generating focus which are then transferred to other elements of the local economic system by linkages and multipliers according to Erickson, R.A. (1975), 'Spatial pattern of income generation in lead firm, growth area linkages systems', Economic Geography, Vol. 51, No.1, January, pp. 17-26.
- (24) For positive results to support the hypothesis that linkages are an important mechanism through which firms maintain their viability in the dynamic space economy, see Schmidt, C.G., (1975): 'Firm linkage structures and structural change: a graph theoretical analysis', Economic Geography, Vol. 51, No. 1, Jan. pp.27-36.

- (25) Moseley, M.J., and Townroe, P.W.T., (1973), 'Linkages adjustment following industrial movements', Tijdschrift voor Economische en Sociale Geografie, 46, pp. 137-44; Taylor, M.J., and Wood, P.A. (1973), 'Industrial linkages and local agglomerations, in the West Midlands metal industries', Transactions and Papers, Institute of British Geographers, 59, pp. 129-154.
- (26) The 1856 O.S. map (10 feet to one mile) shows its precise location at 10-14 Union Street with the owner's property only 40 metres away (Vaux Family Records). Other historical sources used are: White's (1847), General Directory of Newcastle upon Tyne, Sunderland, etc; Vint and Carr, (1844), Directory of Sunderland; Valuation lists (1850).
- (27) The growth of the firm and the process by which it moves to a new location and is prepared to increase its scale is examined by Daly, M.T. and Webber, M.J., (1973), 'The growth of the firm within the city', Urban Studies, 10, pp. 303-31 .

SECTION C. POSSIBILITIES, CONCLUSIONS AND RESERVATIONSChapter 8TOWARDS A WORKING MODEL OF C.A. CHANGE AND SUMMARYIntroduction

It is clear that commercial activity in a C.A. is a product of complex evolutionary processes, some of which are spatial and some are non-spatial. Many of the factors relevant to an understanding of the spatial dynamics of commercial activity in Sunderland are known and have been identified in earlier chapters. They have, however, not always been related in a formalised and conceptual manner. Two approaches to the modelling of C.A. change are now suggested. A summary of the main findings of this research is then given.

A systems approach to C.A. change

The influence of systems thinking in geography is widespread.<sup>(1)</sup> In terms of C.A.'s, the systems approach may help to integrate form and process and takes account of the 'environment' of any commercial behaviour. It also places the emphasis on dynamic situations, eg. the steady state condition, and thereby complements other approaches characterised by stable equilibriums.

In Fig. 42, the principle mechanistic interrelationships identified in the spatial dynamics of the C.A. of Sunderland are shown diagrammatically. The density of commercial activity in a C.A. is maintained by a balance between the supply of new commercial activity and the loss of old commercial activity by outflow or deaths. Maximum intensity occurs through (a) progressive infilling of the commercial space and (b) the restriction (through artificial or natural barriers) of the horizontal spreading out of commercial activity.

The control of the shape of the C.A. is exercised by transport networks, existing stable land use regions and planning legislation. To account for a C.A. which is migrating and at the same time experiencing a greater concentration of commercial activity, four possible explanations can be offered: (i) a systematic increase in the supply of commercial activity to the C.A. by inflow, (ii) a contraction, due to expulsion. outflow or deaths, in one part of the C.A. (iii) a longitudinal flow of activity away from that area of 'discard', (iv) the intensification of intra-C.A. commercial activity by the generation of indigenous new 'births'.

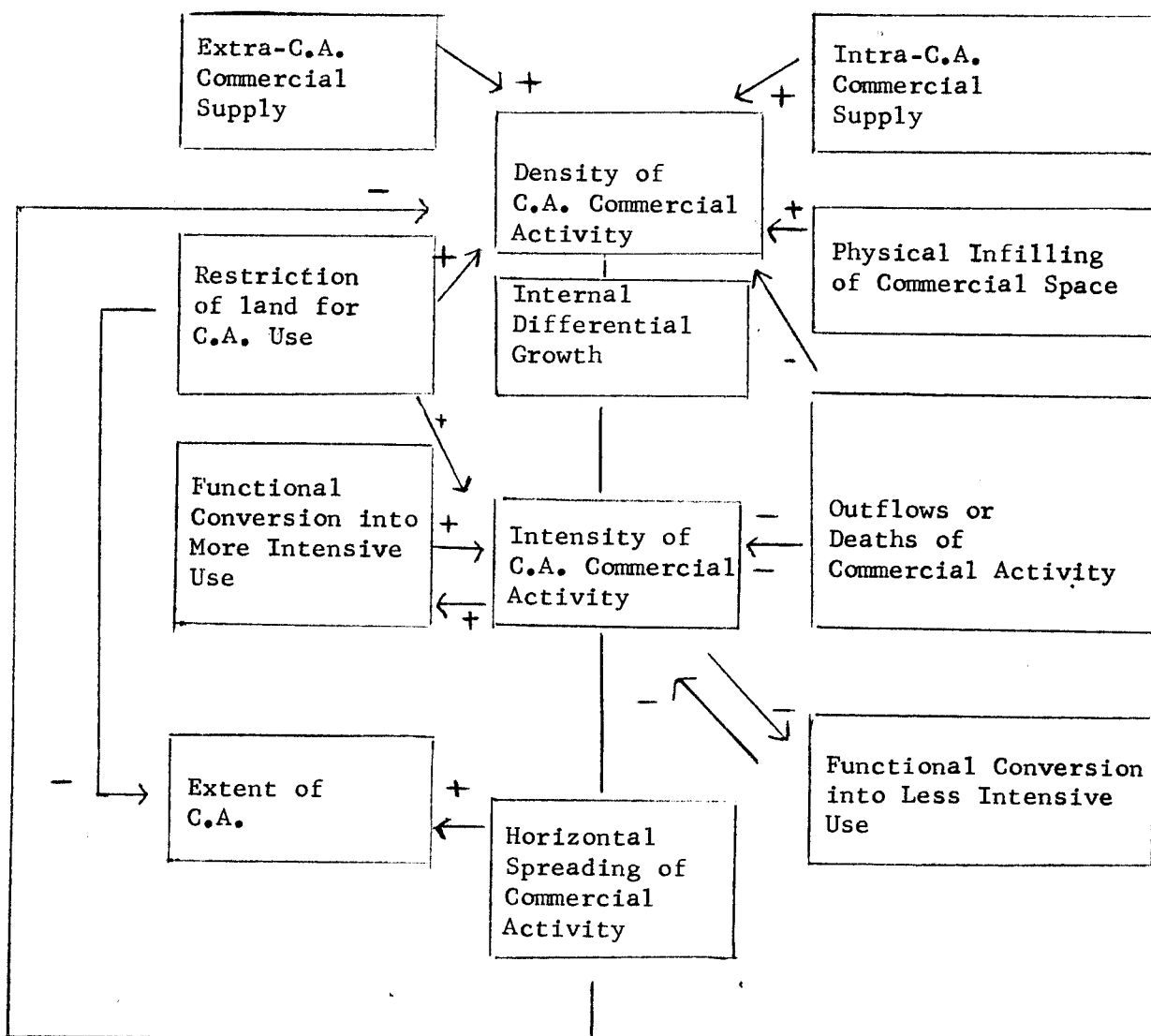

Fig. 42. A systems diagram of the spatial dynamics of commercial activity in a C.A.

The lateral limits of a C.A. can often be defined by functional and physical obsolescence and blight. Furthermore functional conversion either into more or less intensive use determines the changing intensity of commercial activity in a C.A.

Whilst many of the dynamic factors which influence commercial change in a C.A. are known, the relative strengths and the quantitative values to be assigned to these factors are still unknown. That quantitative values of commercial change in a C.A. can be meaningfully assigned is demonstrated by the following conceptualisation.

A working model of C.A. commercial change

The various components of commercial change on a C.A. can be formalised and expressed mathematically to include both the space and time dimensions which are such an integral part of this study.

Five basic elements of the commercial space of a C.A. are identifiable:

- 1) a PROPERTY - a place (an address) where a commercial establishment is located.
- 2) an ESTABLISHMENT - a separate business enterprise.
- 3) a SHARING - the use of a property by two or more establishments.  
(i.e.  $n(1)$  establishments operating from 1 property requires  $n-1$  sharings)
- 4) a BRANCH - the use of an extra (usually adjoining) property by an establishment. (i.e.  $n(1)$  properties occupied by 1 establishment requires  $n-1$  branches)
- 5) a VACANCY - the incidence of a property containing no establishments.

These five basic components are held together in a rigid relationship in any central area which holds true at all times and in all locations.

This relationship is: Number of PROPERTIES + Number of SHARINGS =  
Number of ESTABLISHMENTS + Number of BRANCHES + Number of VACANCIES. (I)

In reality, the spatial frame of a central area can be sub-divided into innumerable locations at any time. For each location ( $\ell$ ) and for any moment in time ( $t$ ), therefore the five parameters can be defined:

- $P(t, \ell)$  - the number of PROPERTIES at time ( $t$ ) in location ( $\ell$ ).  
 $E(t, \ell)$  - the number of ESTABLISHMENTS at time ( $t$ ) in location ( $\ell$ ).  
 $S(t, \ell)$  - the number of SHARINGS at time ( $t$ ) in location ( $\ell$ ).  
 $B(t, \ell)$  - the number of BRANCHES at time ( $t$ ) in location ( $\ell$ ).  
 $V(t, \ell)$  - the number of VACANCIES at time ( $t$ ) in location ( $\ell$ ).

And Equation I above becomes:

$$P(t, \ell) + S(t, \ell) = E(t, \ell) + B(t, \ell) + V(t, \ell) \quad (\text{II})$$

Again it is true for all values of  $t$  and  $\ell$ .

It has been shown in earlier chapters that these five basic parameters are subject to change mechanisms in central areas. These are termed here EVENTS, which can be sub-divided into:-

- (a) GROWTH-EVENTS
- (b) DECAY-EVENTS
- (c) NEUTRAL-EVENTS

and each consists of further elements. GROWTH EVENTS include:

- (i) Building - the creation of a new property
- (ii) Dividing - the creation of a new sharing
- (iii) Birth - the creation of a new establishment
- (iv) Expansion - the creation of a new branch
- (v) Immigration- the movement of an establishment (or branch) into the central area.

Conversely, DECAY EVENTS include

- (i) Demolition - the destruction of an existing property
- (ii) Take-over - the destruction of an existing sharing
- (iii) Death - the destruction of an existing establishment
- (iv) Contraction- the destruction of an existing branch.
- (v) Emigration - the movement of an existing establishment (or branch) out of the central area.

Also NEUTRAL EVENTS can be defined to consist of:-

- (i) Migration - the movement of an existing establishment (or branch) between two locations within the central area.
- (ii) Moving - the movement of an existing establishment (or branch) within a property.

Accordingly, these variables concerned with the number of EVENTS on a given period, between times  $t_1$  and  $t_2$  and in a given location  $e$  can be defined:-

Growth Events

- BG ( $t_1, t_2, \ell$ ) - the number of BUILDINGS
- DV ( $t_1, t_2, \ell$ ) - the number of DIVISIONS
- BT ( $t_1, t_2, \ell$ ) - the number of BIRTHS
- EX ( $t_1, t_2, \ell$ ) - the number of EXPANSIONS
- IM ( $t_1, t_2, \ell$ ) - the number of IMMIGRATIONS

Decay Events

- DM ( $t_1, t_2, \ell$ ) - the number of DEMOLITIONS  
 TO ( $t_1, t_2, \ell$ ) - the number of TAKE-OVERS  
 DT ( $t_1, t_2, \ell$ ) - the number of DEATHS  
 CT ( $t_1, t_2, \ell$ ) - the number of CONTRACTIONS  
 EM ( $t_1; t_2, \ell$ ) - the number of EMIGRATIONS

Furthermore, if  $e_2$  is a second location within the central area, the two variables comprising the Neutral Events can be defined thus:

- MG ( $t_1, t_2, \ell_1, \ell_2$ ) - the number of MIGRATIONS  
 MV ( $t_1, t_2, \ell_1, \ell_2$ ) - the number of MOVINGS

From the above definitions, therefore, it is possible to derive three further equations:-

$$P(t_1, \ell) + BL(t_1, t_2, \ell) = P(t_2, \kappa) + DM(t_1, t_2, \kappa) \quad (\text{III})$$

$$\begin{aligned} E(t_1, \kappa) + BT(t_1, t_2, \ell) + \sum^{\ell_1} MG(t_1, t_2, \ell_1, \ell) \\ + IM(t_1, t_2, \ell) + B(t_1, \ell) + BN(t_1, t_2, \ell) \\ = E(t_2, \ell) + DT(t_1, t_2, \ell) + \sum^{\ell_2} MG(t_1, t_2, \ell_1, \ell_2) \\ + EM(t_1, t_2, \ell) + B(t_2, \ell) + CT(t_1, t_2, \ell) \end{aligned} \quad (\text{IV})$$

$$\begin{aligned} V(t_1, \ell) + S(t_2, \ell) + BL(t_1, t_2, \ell) + \sum^{\ell_2} MG(t_1, t_2, \ell_1, \ell_2) \\ + EM(t_1, t_2, \ell) + DT(t_1, t_2, \ell) + CT(t_1, t_2, \ell) \\ = V(t_2, \ell) + S(t_1, \ell) + DM(t_1, t_2, \ell) \\ + \sum^{\ell_1} MG(t_1, t_2, \ell_1, \ell) + IM(t_1, t_2, \ell) \\ + BT(t_1, t_2, \ell) + BN(t_1, t_2, \ell) \end{aligned} \quad (\text{V})$$

The expression of these relationships in simple mathematical terms may help in the formulation of more sophisticated measures of commercial change in central areas. However, the practical problem of data availability will always remain.

Three more definitions, seem appropriate at this point, in order to measure the intensity of commercial change in any central area. Firstly

it would be helpful to consider the term COMMERCIAL BASE (CB) taken here to mean the total number of premises, establishments, sharings and branchings at any one time ( $t_1$ ).

$$CB = \sum_{t_1}^n P + E + S + B \quad (VI)$$

Secondly, using this expression above, one can define a COMMERCIAL ACTIVITY INDEX (C.A.I.) by dividing the number of events in a period of time by the commercial base at the start of the time period multiplied by 100 per cent:

$$CAI = \frac{\sum_{t_1}^{t_2} GE + DE + NE}{CB(t_1)} \quad (VII)$$

Thirdly, a CHANGE INDEX (CI) can be expressed as the number of Growth Events minus the number of Decay Events for a time period divided by the Commercial Base at the start of the time period, multiplied by 100 per cent:-

$$CI = \frac{\sum_{t_1}^{t_2} GE - \sum_{t_1}^{t_2} DE}{CB} \times 100 \quad (VIII)$$

Various ratios of commercial change have been proposed by other workers <sup>(2)</sup> but those expressed above cover both physical and functional aspects and apply to all locations and at all times. As an operational approach to modelling commercial change in a C.A., they have still to be tested. Hopefully, they may add to existing geographical models of British C.A.s. <sup>(3)</sup>

#### Summary and reservations

This study has been concerned with the spatial dynamics of commercial activity in central Sunderland. As such, it has centred on the nature of change and shifts <sup>(4)</sup> and on the spatial behaviour of the C.A. through time.

The investigation has yielded four important general conclusions. Firstly, the dynamics of commercial activity in the C.A. were closely related to general urban growth and economic circumstances. The structure and morphology of the C.A. changed in response to the relative strengths of the port economy, town economy and regional economy in that chronological order. The incipient C.A. in Sunderland developed in the old port area by

virtue of its initial advantage and was orientated commercially to mercantile interests. The urban industrial growth of Sunderland had, by the end of the nineteenth century, generated a larger and more modern C.A. The new road and rail links across the river wrested the initial advantage from the old port area. The centre of commercial business to migrate went up High Street West and into Fawcett Street. The commercial structure of the C.A. was now strongly influenced by the demands of the growing residential areas to the south and west. The increasing pressure for central commercial space in the twentieth century, and in particular, after the second World War to serve the population in the greater Sunderland region was reflected in a more metropolitan C.A. The establishment of larger commercial outlets, the expansion of existing business and the planned redevelopment involving considerable injections of capital were the spatial outcomes. Redevelopment replaced an entire area with a better organised commercial C.A. containing higher order land uses.

Secondly, the processes and mechanisms by which the C.A. has changed through time are those which have been found in other geographical studies. There is general acceptance of the dynamic processes shaping the C.A. As in many other British C.A.s commercial change was accompanied by land use invasion and succession. Residential streets were penetrated by economically stronger land uses towards the end of the nineteenth century; even in post 1945, the process of invasion was still active in Sunderland. Furthermore, the rate of change was not found to be uniform, for all sub regions of the C.A. or for all land uses. In the formative phase of C.A. growth the pace of change, as far as can be determined, was modest. Distinct 'bursts' of change can be identified for the mid and the late nineteenth century, in the 1920's and in the very recent period. Earlier 'bursts' were attributed to economic factors but later accelerated periods of change were more attributable to social and political considerations.

Thirdly, the behaviour of individual commercial elements within the C.A. followed, broadly, expected patterns. Certain functions, eg. banks, preferred marked centrality in prime locations, their locations in turn influencing other activities, directly and indirectly through, for example, pedestrian flow, and accessibility. Functions had varying locational strategies depending on whether complementary or competing considerations were the more fundamental.

Fourthly, the structure of the C.A. was analysed using a modified Murphy-Vance system of analysis and found to exhibit the expected features. A commercial core could be realistically delimited, retail and office sub regions identified and a zonation of changing land uses away from a central cell was observable. Several terms of 'discard' and 'assimilation' are of value but they have to be supplemented with other details of the principal components which were found to be relevant in the specific case of Sunderland. Change in the C.A. was largely embodied by growth in the west and decay in the east. A redistribution through migration and 'deaths' and 'births' effected alterations in the intensity of use of the commercial space. Functional shifts were found to be related to physical change.

The full exposition of any one of these themes is subject to a number of difficulties. The spatial dynamics of commercial activity of central Sunderland is extremely complex for one moment of time, let alone for nearly two centuries. Empirical evidence presented in their support is far from definitive. The considerable degree of order and stability in commercial activity has been recognised despite the discontinuous nature of the data.

Not all the pertinent factors have been exhaustively isolated. For instance, the role of planning in C.A. change has only been superficially explored. No attempt has been made to extrapolate trends or to forecast future C.A. structure and behaviour.

A definitive study of commercial change in a C.A. should take account of many influences. Tentative statements have been made in this study supported by the evidence collected from central Sunderland. Substantive statements, however, must await much more field results. The complete understanding of the central area is an ideal which can scarcely be attained. Hopefully, this study has contributed towards that ideal.

References and end notes

- (1) A helpful guide is: Walmsley, D.J., (1972), 'Systems theory' a framework for human geographical enquiry'. Research School of Pacific Studies, Australian National University. Canberra.
- (2) For example: Berry, B.J.L., Parsons, S.J., and Platt, R.H., (1968), 'The impact of urban renewal on small business : the Hyde Park-Kenwood case', Centre for Urban Studies, University of Chicago.
- (3) For example: Davies, R.L., (1972), 'Structure models of retail distribution', Transactions, Institute of British Geographers, No. 57, November, pp. 59-82, Thomas, R.W., (1971), 'The comparative analysis of British city central areas', Ph.D. thesis, Nottingham University.
- (4) The two terms are not identical and freely interchangeable, (see Lynch, K., (1972), What Time is this Place?) Buildings may be physically and structurally changed and change their use, but individual firms and business shift their place of work and location.

## BIBLIOGRAPHY

- Ackerman, E.A., (1958), 'Geography as a fundamental research discipline' Research Paper No. 53, Dept., of Geography, University of Chicago, June.
- Adams, J.S., (1969), 'Directional bias in intra-urban migration', Economic Geography, Vol. 45, January, No. 1, pp. 302-
- Alexander, D., (1970), 'Retailing in England during the Industrial Revolution', (London).
- Alexander, J.A. (1954), 'The basic/non basic concept', Economic Geography, Vol. 30, pp. 246-261.
- Alonso, W., (1960), 'A theory of the urban land market', Papers and Proceedings of the Regional Science Association, Vol. 6, pp. 149-157.
- Alonso, W., (1964), 'Location and land use', Cambridge, Mass.
- Arneem, L. and Erlandsson, W., (1968), 'Delimiting the C.B.D. in small central places', Svensk Geografisk Arsbok, (44), pp. 90-101.
- Bachi, R., (1976), 'Geostatistical analysis of internal migrations', Journal of Regional Science, Vol. 16, No. 1, pp. 1-19.
- Bain, G.W., (1905), 'Early days of banking in Sunderland', Antiquities of Sunderland, Vol. 6, pp. 76-93.
- Bateman, M., (1968), 'The nature and processes of urban renewal in the central areas of nine towns of West Yorkshire during the post war period' Unpublished Ph.D. thesis, Leeds University.
- Beesley, M., (1955), 'The birth and death of industrial establishments: experience in the West Midlands combination', Jo. of Industrial Economics, Vol. 4, pp. 45-61.
- Berry, B.J.L., (Ed.), (1972), 'City classification, Handbook, Methods and applications', (J. Wiley & Sons Inc.).
- Berry, B.J.L., Parsons, S.J. and Platt, R.H., (1968): 'The impact of urban renewal on small business': the Hyde Park-Kenwood case', Centre for Urban Studies, Univeristy of Chicago.
- Blair, D.J. and Biss, T.H., (1967), 'The measurement of shape in Geography: an appraisal of methods and techniques'. Bulletin of Quantitative Data for Geographers, No. 11, University of Nottingham.
- Blij, H.J.,de., (1962) 'The functional structure and C.B.D. of Laurence Marquis, Mozambique, Economic Geography, 38, pp. 56-77.
- Bohnert, J.E. and Mattingly, (1964), 'Delimitation of the C.B.D. through time', Economic Geography, Vol. 40, pp. 337-347.
- Bourne, L.S., (1967), 'Private redevelopment of the central city: spatial processes of structural change in the city of Toronto', Research Papers No. 112, University of Chicago.
- Bourne, L.S., (1971), 'Physical adjustment processes and land use succession: a conceptual review and central city example'. Economic Geography, Vol. 47, January, pp. 1-15.

- Bourne, L.S., (1969),: 'A spatial allocation - land use conversion model of urban growth'. Journal of Regional Science, Vol.9, No.2 pp. 261-272.
- Bowden, M.J., (1971),: 'Downtown through time: delimitation expansion and internal growth', Economic Geography, Vol. 47, No. 2, April, pp.121-135.
- Bowling, H., (1969), 'Some chapters in the history of Sunderland', (S/land).
- Breese, G., (1949), 'The daytime population of the Central Business District of Chicago, with particular reference to the factor of transportation', University of Chicago Press. Chicago reprinted Ch. 8, in 'Contributions to Urban Sociology', (Eds. E.W. Burgess, & D.J. Bogue, pp. 112-128.
- Briggs, A., (1968), 'Victorian Cities', (Hammondsworth)
- Brown, L.A. (1970), 'On the use of Markov chains in movement research', Economic Geography, (June), pp. 393-403.
- Browning, C.E., (1958), 'The structure of the Mexico city C.B.D.' University microfilms, Ann Arbor.
- Burgess, E.W. (1925), 'Growth of the city', in Park, R.E. Burgess, E.W., and McKenzie, R.D., (Eds.): The City, University of Chicago Press, Chicago.
- Campbell, N., (1970), 'An application of the core frame concept to the C.B.D., London, Ontario in three dimensions, Ontario Geographer(5)pp.83-84.
- Carter, H., and Rowley, G., (1966), 'The morphology of the Central Business District of Cardiff', Trans. Inst. of British Geographers, 38, June, pp. 119-134.
- Carter, H., (1972), 'The study of urban geography' (Arnold)
- Carter, H., (1976), 'Urban Geography in Britain, 1945-75', in 'Human Geography in France and Britain', (Eds: Clarke, J.I. and Pinchernel, P.) pp. 64-72, Social Science Research Council.
- Census of Distribution and other services (1957,1961,1966,1964), HMSO.
- Census of Population for Sunderland (1801-1971), HMSO.
- Chapin, F.S. (Jnr.) and Weiss, S.F., (19 ), 'Urban dynamics'.
- Checkland, S.G., (1964), 'The British industrial city as history'. Urban Studies, Vol. 1, No. 1, 1964, pp. 34-54.
- Clark P.J. and Evans, F.C., (1954), 'Distance to nearest neighbour as a measure of spatial relationships in populations,' Ecology, 35, pp. 445-453.
- Clarkson, J.D., (1970), 'Ecology and spatial analysis', Annals of the Association of American Geographers, Vol. 60, pp. 700-716.
- Carol, H., (1960), 'The hierarchy of central functions within the city,' Annals of Association of American Geographers, 50, pp. 419-38.

- Collins, L., (1973), 'Industrial size distribution and stochastic processes', Progress in Geography, Vol. 5, pp. 120-165.
- Collins, L., (1975), 'An introduction to Markov chain analysis', Catmag. No. 1, pp.36.
- Collinson, G.W., (1903), 'Post Office development in Sunderland', Antiquities, Vol. 4, pp. 1-7.
- Commissioners for enquiring into the state of the large towns and populous districts (1845), HMSO, Second Report.
- Cowan, P., (Finr, D., Ireland, J., Jordon, C. et al. (1969), 'The office : a facet of urban growth' (New York).
- Dacey, M.F., (1972), 'An explanation for the observed dispersion of retail establishments in urban areas'. Environment and Planning, Vol. 4, pp. 323-330.
- Dalton, R., Garlick, J., Minshull, R., Robinson, A., (1972), 'Correlation techniques in Geography', (Philip).
- Daly, M.T., Webber. M.J., (1973), 'The growth of the firm within the city'. Urban Studies, 10, pp. 303-317.
- Davies, D.H., (1959), 'Boundary study as a tool in C.B.D. analysis : an interpretation of certain aspects of the boundary of Cape Town's Central Business District', Economic Geography, Vol. 35, pp.322-345.
- Davies, D.H., (1960), 'Urban geography and planning on the C.B.D. of Cape Town'. South African Journal of Science, Vol. 56, No. 5.
- Davies, D.H., (1960), 'The hard core of Cape Town's Central Business District : an attempt at delimitation', Economic Geography, Vol. 36, pp. 53-69.
- Davies, R.J. and Rajah, D.S., (1965), 'The Durban C.B.D.: a boundary delimitation and racial The South African Geographical Journal, 47, December, pp. 45-48.
- Davies, R.L., (1972), 'Structural models of retail distribution', Transactions of the Institute of British Geographers, No.57, Nov.pp.59-82.
- Davies, R.L., (1976), 'Marketing Geography', (R.P.A.)
- Davies, W.K.D., (1972), 'Conceptual Revolution in Geography' (Univ. of London Press Ltd.)
- Davies, W.K.D., Giggs, J.A., and Herbert, D.T., (1969), 'Directories, rate books, and the commercial structure of towns', Geography, Vol. 53, pp. 41-54.
- Diamond, D.R., (1962), 'The Central Business District of Glasgow', Proceedings of I.G.U. symposium in Urban Geography, Lund studies, in Geography, (B) pp. 525-534.
- Dicken, P., (1971), 'Some aspects of the decision-making behaviour of business organisations. Economic Geography, Vol. 47, No.3,July.pp.426-437.

- Dickinson, G.C., (1963), 'Statistical Mapping and the Presentation of Statistics', (Arnold).
- Durden, D. and Marble, D.F., (1970), 'The role of theory in C.B.D. planning', Journal of American Institute of Planning, pp. 10-16.
- Durham Chronicle and Sunderland Times, March 17th 1832.
- Edwards, K.C., (1962), 'Trends in central area differentiations', Proc. of the I.G.U. Lund Studies in Geography, Ser.B. 24, pp.519-524.
- Eichenbaum J. and Gale, S. (1971), 'Form, junction and process: a methodological inquiry. Economic Geography, Vol. 47, pp. 525-544
- Erickson, R.A., (1975), 'Spatial pattern of income generation in lead firm, growth area linkage systems', Economic Geography, Vol. 51, No. 1, January, pp.1/-20.
- Foley, D.L., (1952), 'The daily movements of population into Central Business Districts', American Sociological Review, Vol. 17, pp.538-543.
- Foley, D.L., (1967), in 'Explorations into urban structure', (Ed. Webber, M. et.al.)
- Garbutt, G., (1817), 'Plan of Sunderland, Bishopwearmouth and Monkwearmouth (dated July 14th).
- Garbutt, G., (1819), 'A historical and descriptive view of the parishes of Monkwearmouth and Bishopwearmouth and the port and Borough of Sunderland.
- Getis, A. (1964), 'Temporal land use pattern analysis with the use of nearest neighbour and quadrat methods', Annals of Association of American Geographers, Vol. 54, pp. 391-399.
- Goad, C.E., 'Insurance plans of Sunderland, 1894,1927,1948,1959.'(London)
- Goddard, J.B., (1967), 'The internal structure of London's central area' in Heineneijer, W.F., Van Hulton, M. and de Vreis Reilingh, H.D. (1967), Eds. Urban core and inner city. Proceedings of the international study week, pp. 118-140, Amsterdam (Leiden).
- Goddard, J.B., (1970), 'Functional regions with the city centre: a study by factor analysis of taxi flows in central London', Transactions, Institute of British Geographers, No. 49, pp. 161-182.
- Goddard, J.B., (1973), 'Office Linkages and Location', Progress in Planning (1), pp. 111-232.
- Good, W.J. and Malt, P.K., (1952), 'Methods in Social Research' McGraw-Hill.
- Gorman, D.A. and Hitchcock, S.T. (1959), 'Characteristics of traffic entering and leaving the Central Business District', Public Roads (xxx) No. 9, August, pp. 213-220.
- Gregory, S., (1968), 'Statistical methods and the geographers', 2nd Ed. (Longmans).

- Griffin D.W., & Preston, R.E., (1968), 'Land use in the central commercial area', Journal of Geography, Vol.67, No. 6, September, pp. 342-351.
- Griffin, D.W., & Preston, R.E., (1966), 'A restatement of the transition zone concept', Annals of the Association of American Geographers, Vol. 66, pp. 339-350.
- Gruchy, G.F. de, (1975), 'Some land-value relationships in Brisbane's Central Business District', Ekistiko, Vol. 39, No. 233, April, pp.268-270.
- Guest, A.M., (1972), 'Urban history, population densities, and higher status residential location', Economic Geography, Vol. 48, No. 4, October, pp. 375-387.
- Hall, P. (Ed), (1965), 'Land Values', (Sweet & Maxwell).
- Hammond, R., & McCullagh, P.S., (1974), 'Quantitative techniques in Geography: an introduction', (Clarendon).
- Hansen, W.G., (1959), 'How accessibility shapes land use', Journal of American Institute of Planners, Vol. 25, pp. 73-6.
- Harris, C.D. & Ullman, E.L., (1945), 'The nature of cities', Annals of the American Academy of Political and Social Science, Vol. 242, November, pp. 7-17.
- Hart, J.F., (1954), 'Central tendency in areal distributions', Economic Geography, Vol. 30, pp. 44-59.
- Hartenstein, W., & Staak, G., (1967), 'Land use in the urban core', Pt. 1, pp. 35-52 in H.F. Heinemeijer, M.Van Hulton and H.D. de Vreis Reilirgh, (Eds.) 'Urban core and inner city', Proceedings of the International Study Week. (Amsterdam).
- Hartman, G.W., (1950), 'The Central Business District', a study in Urban Geography', Economic Geography, Vol. 26, pp. 237-244.
- Harvey, D.W., (1966), 'Geographical processes and the analysis of point patterns', Transactions, Institute of British Geographers, No.40, pp. 81-95.
- Harvey, D.W., (1968), 'Pattern, processes and the scale problem in geographical research', Transactions of Institute of British Geographers. pp. 71-78.
- Hautemaki, L. and Siirila, S. (1969), 'Delimiting the C.B.D. in Finland', Fennia, (99), No. 4, pp. 1-40.
- Hawley, A., (1950), 'Human Ecology - a theory of community structure' New York.
- Hazen, W.E., (1964), 'Readings in Population and Community Ecology' New York.
- Heinemiger, W.F., Van Hulton, M., and de Vreis Reilingh, H.D. (1967), 'Urban core and inner city', Proceedings of the International Study Week, Amsterdam.

- Hoare, A.G., (1975), 'Linkage flows, locational valuation and industrial geography - a case study of Greater London', Environment and Planning, A, 1975, Vol. 7, pp. 41-58.
- Hoel, P.G., et al, (1972), 'Introduction to stochastic processes'
- Holmes, R.S., (1974), 'Identifying nineteenth century properties', Area, Vol. 6, No. 4, pp. 273-277.
- Horwood, E.M., & Boyce, R., (1959), 'Studies of the Central Business District and Urban Freeway Development, University of Washington, Seattle.
- Hoyt, H., (1939), 'The structure and growth of residential neighbourhoods in American cities', U.S. Federal Housing Admin., Washington.
- Herbert, D.T., (1972), 'Urban Geography'.
- Herbert, D.T. and Davies, W.K.D., (1968), 'The C.B.D. of Swansea - an introductory study of functional structure', Swansea Geography.
- Hudson, J.C., (1969), 'A location theory for rural settlement', Annals of Association of American Geographers, Vol. 59, pp.365-381.
- Hughes, A.C. (1966), 'The delimitation of the Central Business District of Washington, D.C. over time', unpublished M.A. thesis, Univ. of Maryland.
- Hurd, R.M., (1924), 'Principles of city land values'.
- Hurst, M.E. Eliot, (1974), 'Micromovement and the urban dweller', Selection 29 in Hurst M.E. Eliot (Ed.). Transportation Geography: comments and readings, pp. 482-509.
- Janelle, D.G., (1969), 'Spatial reorganisation: a model and concept', Annals of the Association of American Geographers, Vol.59, pp. 348-364.
- Jeffreys, J.B., (1954), 'Retail Trading in Britain', 1850-1950.
- Johnson, E.S., (1941), 'The national history of a Central Business District with particular reference to Chicago. Ph.D. thesis, University of Chicago.
- Johnson, E.S., (1956), The function of the C.B.D. in the Metropolitan Community. Chapter 4 in Cities and Society - a revised reader in urban sociology, (Eds. P.K. Holt and A.J. Reiss), pp. 248-259.
- Kahn, M.A. (1972), 'The growth and morphology of the central area of Coventry', Ph.D. thesis, Birmingham University, (3 vols.)
- Kazlowski, J., Hughes, J.T. & Brown R., (1972), 'Threshold Analysis - a quantitative planning method'.
- Kellet, J.R., (1969), 'The Impact of Railways on Victorian Cities'. (Routledge & Kegan Paul Ltd.)
- Kelly's Post Office Directory of Durham, 1858, 1873.
- King, L.J.,(1969), 'The analysis of spatial form and its relation to geographic theory', Annals of Association of American Geographers, (59), pp. 573-595.

- Kinwood, A.G., (1963), 'Residential building activity in N.E. England', Manchester School of Economic and Social Studies, Vol. 31, May, pp.115-128.
- Lawton, R., (1972), 'An Age of Great Cities', Town Planning Review, Vol. 43, No. 3, July, pp. 199-224.
- Laxton, P., (1970), 'Liverpool in 1848', in Patmore, J.A. and Hodgkiss, A.G., (Eds), Merseyside in Maps (London, 1970), pp. 20-21.
- Lee, Y., (1974), 'A conceptual discussion and empirical analysis of commercial land use succession'. Environment and Planning, A. Vol. 6, pp. 655-674.
- Lee, Y., (1974), 'An analysis of spatial mobility of urban activities in downtown Denver', Annals of Regional Science, Vol. 8, pp. 95-108.
- Levein, C.P.A., (1973), 'Delimitation and Comparative Analysis of the Central Areas of Medium Sized Towns in Central Scotland', Ph.D. Edinburgh University.
- Lever, W.F., (1972), 'The intra-urban movement of manufacturing: a Markov approach', Transactions, Institute of British Geographers, No.56, July, pp. 21-37.
- Lewis, G.J., (1974), 'Pedestrian flows in the central area of Leicester: a study in spatial behaviour', East Midland Geographer, Vol. 6, Pt.2, No. 42, December, pp. 79-91.
- Lynch, K., (1972), 'What time is this place'? M.I.T., Cambridge U.S.A.
- McDonald, J.F., (1975), 'Some causes of the decline of central business district retail sales in Detroit', Urban Studies, Vol. 12, pp. 229-233.
- Majid, R., (1970), 'The C.B.D. of Dacca', Oriental Geographer, Vol.14, Pt. 1, pp. 44-63.
- Mark, J., (1974), 'British Brewing Industry', Lloyds Bank Review, No. 112, April, pp. 31-45.
- Marshall, C.E., (1959), 'The C.B.D. of Johannesburg', Proceedings of the South African Institute of Town Planners, Vol. 52, pp. 60-67.
- Mattingly, P.F., (1964), 'Delimitation and movement of C.B.D. boundaries through time: the Harrisburg example', Professional Geographer, 16, No. 6, November, pp. 9-13.
- Medhurst, D.F., & Parry, J., Lewis, G., (1969), 'Urban decay - an analysis and policy'. (Macmillan).
- Morgan, R.H., (1974), 'Non-response in postal questionnaire surveys'. Area, Vol. 6, No. 4, pp. 309-314.
- Moseley, M.J. & Townroe, P.W.T., (1973), 'Linkages adjustment following industrial movement'. Tijdschrift Voor Economische en Sociale Geographie, 46, pp. 137-44.
- Minett, J., (1970), 'If the city is not a tree, nor is it a system'. Planning Outlook, Vol. 16, Spring, pp. 4-18.
- Mika, P.J., (1965), 'A comparative study of some English and American Central Business Districts'. Unpublished Ph.D. Clark University, U.S.A.

- Mitchell, W.C., (1919), 'A history of Sunderland', (Sunderland).
- Mumford, L., (1938), 'The culture of cities', (Routledge, London).
- Murphy, P.E., (1970), 'A temporal study of the spatial adjustments of a C.B.D. in terms of central place principles', Tijdschrift voor Economische en Sociale Geographie, Vol. 61, Pt. 1, pp. 16-21.
- Murphy, R.E., (1954), 'Delimiting the C.B.D.'. Economic Geography Vol. 30, No. 3, July.
- Idem, (1954), '(A comparative study of nine Central Business Districts', Economic Geography, Vol. 30, No. 4, October.
- Murphy, R.E., Vance, J.E., Epstein, B.J., (1955), 'Internal structure of the C.B.D.', Economic Geography, Vol. 31, No. 1, January. pp.21-46.
- Murphy, R.E., (1966), 'The American city: an urban geography' (McGraw Hill).
- Murphy, R.E. (1971), 'The Central Business District: a study in urban geography', (Longmans).
- Myrdal, G.M., (1957), 'Economic theory and underdeveloped regions', (London).
- Nef, J.U., (1932), 'The rise of the British coal industry', (London).
- Nelson, R.L., (1958), 'The selection of retail locations', (F.W. Dodge, New York).
- Olsson, G. & Gale, S., (1967), 'Spatial theory and human behaviour', Papers and Proceedings of Regional Science Association, Vol.15, pp.354-368.
- Openshaw, S., (1973), 'Processes in urban morphology with special reference to South Shields', unpublished Ph.D., thesis, Univ. of Newcastle.
- Openshaw, S., (1974), 'A theory of the morphological and functional development of the townscape in an historical context', Seminar Paper, No. 24, Dept. of Geography, University of Newcastle upon Tyne.
- Ordnance Survey - 'maps of central area (all editions and scales).
- Pahl, R.E., (1968), 'Spatial structure and social structure', Centre for Environmental Studies, W.P. 10, (July).
- Pahl, R.E., (1970), 'Whose city? And other essays on sociology and planning' (Longman).
- Park, R.E., Burgess, E.W., & McKenzie, R.D., (1925), 'The city', (University of Chicago).
- Parry-Lewis, J., (1965), 'Building cycles and Britain's growth'.
- Parson & White (1828), 'History, directory and gazetteer of the counties of Durham and Northumberland, Vols. 1 and 2.'
- Patterson, J., (1902), 'C. Vaux & Sons Ltd. : the Brewery, Castle Street, (Sunderland).
- Parzan, E., (1962), 'Stochastic processes'.

- Pigot & Co., (1828, 1834), 'Directory of Durham'.
- Potts, T., (1892), 'Sunderland: a history of the town, port trade and commerce', (Sunderland).
- Pred, A.R., (1965), 'Industrialisation, initial advantage, and American metropolitan growth', Geographical Review, 55,(2), pp.158-185.
- Pred, A.R., (1966), 'Manufacturing in the American mercantile city, 1800-1840', Annals of Association of American Geographers, Vol. 56, pp. 307-338.
- Pred, A.R., (1966), 'The spatial dynamics of the U.S. urban-industrial growth 1800-1914 : interpretative and theoretical essays. (M.I.T. Press).
- Pred, A.R. (1969), 'Behaviour and location', Lund studies in Geography, Ser. B, Human Geography, No. 28.
- Pred, A.R., (1973), 'Urbanisation, domestic planning problems and Swedish geographic research', Progress in Geography, (Ed. C. Board et.al). Vol. 5.
- Preston, R.E., (1966), 'A zone in transition : a study of urban land use patterns. Economic Geography, Vol. 42, January, pp.236-260.
- Proudfoot, M.S., (1937), 'City Retail Structure', Economic Geography, Vol. 13, pp. 425-
- Rain, J., (1792?), 'Eye plan of Sunderland and Bishopwearmouth'.
- Randall, R.T., (1901), 'History of the parish boundaries in the Borough of Sunderland and neighbourhood', Antiquities of Sunderland, Vol.2,pp.1-16.
- Rannells, J., (1956), 'The core of the city : a pilot study of changing land uses in central business districts, (New York).
- Ratcliff, R.V., (1953), 'The Madison Central Business Area: a case study of functional change. Wisconsin Commerce Papers, Vol. 1. No. 5, Bureau of Business Research and Service, University of Wisconsin, Madison, Wisconsin.
- Rate Books, (1838,1850,1901,1973), Sunderland Borough, Rates and Rateable Values (1966-67), Part II - (H.M.S.O.).
- Relief for the Parish of Sunderland, (1818), Parish Paupers of Sunderland, Local Pamphlets, Vol. 3.
- Report on the Census of Distribution and other Services, (1961,1966), Board of Trade.
- Report on the Methodology of Field Surveys, Town Centre Map, (1970), Report No. 2, Planning Department, Sunderland Borough.
- Reynolds, R.B., (1960), 'Retail specialisation of C.B.D.'s. Journal of American Institute of Planners, Vol. 26, No. 6, November, pp.313-316.
- Robertson, I.M., (1970), 'The national grid and social geography', Geography, Vol. 55, Pt.4, November, pp. 426-432.

- Robson, B.T., (1969), 'Urban analysis - a study of city structure with special reference to Sunderland,' C.U.P.
- Robson, B.T., (1973), 'Urban growth : an approach', (Methuen).
- Robson, T., (1827), 'Plan of Sunderland, Bishopwearmouth and Monkwearmouth', (November 22nd).
- Rogers, A., (1969), 'Quadrat analysis of urban dispersion (1) theoretical techniques', Environment and Planning, Vol. 1, pp. 47-80.
- Rogers, A., (1969), 'Quadrat analysis of urban dispersion (2), case studies of urban retail systems, Environment and Planning, Vol. 1, pp.155-171.
- Rogers, A., (1974), 'Statistical analysis of spatial dispersion, the quadrat method', (Pion). (3)
- Rogers, A., & Raquillet, R., (1972), 'Quadrat analysis of urban dispersion, (4), spatial sampling, Environment and Planning, Vol. 4, pp. 331-345.
- Ross, S.H., (1971), 'The C.B.D. of Mexico City as indicated on the Sanborn Maps of 1906'. Professional Geographer, Vol. 23, pp.31-39.
- Rostow, W.W., (1960), 'The stages of economic growth: a non communist manifesto', (Cambridge).
- Rowley, G., (1965), 'A note on C.B.D. research in the U.K.', Professional Geographer, XVII, No. 6, pp. 15-16.
- Rowley, G., & McShepherd, P., (1976), 'A source of elementary spatial data for town centre research in Britain', Area, Vol. 8, No.3, pp.201-208.
- Rube, M.M. & Haynes, K.E., (1974), 'Central place theory and the C.B.D.', Ecumen, 6, pp. 31-35.
- Sargent, G.S., (1972), 'Toward a dynamic model of urban morphology', Economic Geography, Vol. 48, No. 4, pp.357-374.
- Sargent, G.S., (1974), 'The spatial solution of Greater Buenos Aires, Argentina, 1870-1930': Centre for Latin American Studies, Arizona State University.
- Scola, R., (1975), 'Food markets and shops in Manchester, 1770-1870', Journal of Historical Geography, Vol. 1, No. 2, April, pp.153-168.
- Schmid, C.F. (1937), 'Social saga of two cities - an ecological and statistical study of social trends in Minneapolis and St. Paul. Minneapolis Council of Social Agencies Bureau of Social Research.
- Schmidt, S.G., (1975), 'Firm linkage structure and structural change: a graph theoretical analysis'. Economic Geography, Vol. 51, No. 1 pp.27-36.
- Schofield, (1793), Universal Directory, (Sunderland Section).
- Scholler, P., (1962), 'Centre shifting and centre mobility in Japanese cities, Proceedings of I.G.U. symposium in urban geography, Lund Studies, Vol. 12, Ser. B, (24).
- Scott, P., (1959), 'The Australian C.B.D.' Economic Geography, 35, No. 4, pp.290-314.

- Sharpe, G.B., (1953), 'Measuring the pull of the C.B.D. to the suburbs'. Urban Land, Vol. 12.
- Sharpless, J.B., (1976), 'The economic structure of port cities in the mid nineteenth century: Boston and Liverpool, 1840-1860'. Journal of Historical Geography, Vol. 2, No. 2, pp.131-143.
- Sherwood, K.B., (1970), 'Some applications of the nearest neighbour technique to the study of movement of intra-urban functions'. Tijdschrift voor Economische en Sociale Geografie, Vol. 61, pp.41-48.
- Sjoberg, G., (1960), 'The preindustrial city', (New York).
- Solomen, R.J., (1969), 'Property values as a structural element of urban evolution', Economic Geography, Vol. 45, No. 1, January, pp.1-28.
- Smailes, A.E., (1955), 'The C.B.D. of cities', Geographical Review, XV, pp. 574-577.
- Smith, J.W. & Holden, T.S., (1953), 'Where shops are born: a history of shop building on the River Wear', (Sunderland).
- Smith, P.J., & Bannon, M.J., (1970), 'The dimensions of change in the central area of Edmonton, 1946-1966, in Sewell, W.R.D. and Foster, H.D. (Eds.) The Geographer and Society, (1970), Western Geographical Series, Vol. 1, Chapter 14, pp. 184-199, University of Victoria.
- Steed, G.P., (1968). 'The changing milieu of the firm: a case study of a shipbuilding concern'. Annals of Association of American Geographers, Vol. 58, 3, September, pp.506-525.
- Sunderland Echo, (various).  
 Sunderland and Durham Gazette, (1831- ).  
 Sunderland Herald (1831- ).  
 Sunderland Beacon (later Times) (1838- ).
- Survey of Factors Governing the Location of Offices in the London Area (1964). Prepared for the Location of Offices Bureau by The Economist Intelligence Unit, January, pp.180.
- Sykes, (1833-1867), Local Pamphlets, Vol. 3.
- Taylor, G., (1942), 'Environment, village and city: a genetic approach to urban geography, with some reference to possibilism', Annals, Association of American Geographers, (March), pp.49.
- Taylor, G., (1951), 'Geography in the Twentieth Century'. (Methuen).
- Taylor, M.J., & Wood, P.A., (1973), 'Industrial linkage and local agglomerations in the West Midlands metal industries', Trans. Institute of British Geographers, 59, pp. 129-154.
- Taylor, W.G., (1967), 'Methods of Central Business District and Central Area delimitation'. Vols. 1 and 2, Edinburgh School of Town and Country Planning.
- Thomas, R.W., (1971), 'The comparative analysis of British city central areas'. Ph.D. thesis, Nottingham University.

Thomas, R.W., (1971), 'The retail structure of the central area: an example of comparative analysis on Geography', paper presented to I.B.G. Urban Study Group, Liverpool.

Townroe, P.M., (1971), 'Industrial location decisions: a study in management behaviour'. University of Birmingham, Centre of Urban and Regional Studies, Occ. Paper, No. 15.

Townroe, P.M., (1972), 'Some behavioural considerations on the industrial location decision', Regional Studies, Vol. 6, September, pp.261-272.

Ullman, E.L., (1958), 'Regional development and the geography of concentration', Papers and Proceedings of the Regional Science Association. Vol. 4, Philadelphia, pp. 179-198.

Ullman, E.L., (1962), 'Presidential Address; The nature of cities reconsidered'. The Regional Science Association, Papers and Proceedings, Vol. 9, pp. 7-23.

Vance, J.E. Jnr., (1955), 'Delimitation and analysis of the Central Business District of Little Rock, Arkansas, Arkansas Academy of Science Proceedings, Vol. VIII.

Vance, J.B.L., (1958), 'The Central Business District of the British city with special reference to Nottingham'. Unpublished Ph.D. Graduate School of Geography, Clark University, Worcester, U.S.A.

Vance, J.E. Jnr., (1962), 'Emerging patterns of commercial structure in American cities', Proceedings of the I.G.U. Symposium in Urban Geography, Ser. B. Human Geography, Royal University of Lind, Sweden, pp.485-518.

Vance, J.E. Jnr., (1971), 'Land assignment in the pre-capitalist, capitalist and post-capitalistic city', Economic Geography, Vol. 47, No. 2, April, pp. 101-120.

Varley, R.A., (1968), 'Land use analysis in the city centre with special reference to Manchester, unpublished M.A. thesis, Aberystwyth, University.

Vint and Carr, (1844), 'Directory of Sunderland'.

Walmsley, D.J., (1972), 'Systems theory: a framework for human geographical enquiry', H:G/7, Research School of Pacific Studies, Australian National University, Canberra.

Ward, D., (1962), 'The pre urban cadaster and the urban pattern of Leeds', Annals of the Association of American Geographers, Vol. 52, pp. 150-166.

Ward, D., (1966), 'The industrial revolution and the emergence of Boston's Central Business District', Economic Geography, Vol. 42, January, pp. 152-171.

Ward's directories of Sunderland, 1884-1889-1890, 1929, 1931, 1933-39.

Waters, R.A. (1900), 'Hendon: past and present. (Sunderland).

Watson, J.W., (1955), 'Geography: a discipline in distance', Scottish Geographical Magazine, Vol. 71, pp. 1-13.

- Weaver, D.C., (1969), 'Changes in the morphology of three American C.B.D.'s, 1952-1966,' Professional Geographer, 21, pp. 406-410.
- Webber, M., & Foley, D.L., (1967), 'Explorations into urban structure'. (University Penn. State).
- Weiss, S.F., (1957), 'The C.B.D. in transition', Research Paper No.1, City and Regional Planning, University of Carolina.
- Wellan, W., & Co., (1856,1865), 'History, Topography and Directory of Durham.'
- White, (1847), 'General directory of Newcastle upon Tyne'.
- Whiteland, J.W.R., (1972), 'Building cycles and the spatial pattern of urban growth', Transactions, Institute of British Geographers, No. 56, July, pp. 39-55.
- Whysall, P., (1974), 'The changing pattern of retail structure of Greater Nottingham, 1912-1971', unpublished Ph.D. thesis, University of Nottingham.
- Wild, M.T., & Shaw, G., (1974), 'Locational behaviour of urban retailing during the nineteenth century: the example of Kingston upon Hull, Transactions, Institute of British Geographers, No. 61, March, pp. 101-118.
- William-Olson, W., (1940), 'Stockholm: to structure and development', Geographical Review, Vol. 30, pp. 420-438.
- Williams, (1844), Commercial directory of Newcastle, North and South Shields, Sunderland.
- Wilson, L.S., (1936), 'Functional areas of Detroit, 1890-1933, Papers of the Michigan Academy of Science, Arts and Letters, XXII, pp. 397-409.
- Woolacott, D., (1907), 'The physical geography of Sunderland and District', Antiquities, Vol. 8, pp. 75-78.
- Wolpert, J., (1965), 'Behavioural aspects of the decision to migrate', Papers and Proceedings of Regional Science Association, Vol.15, pp.369-380.
- Yeates, M.H., (1965), 'Some factors affecting the spatial distribution of land values, 1910-1960', Economic Geography, Vol.41, pp.52-70.
- Young, B.S., (1961), 'Aspects of the Central Business District of Port Elizabeth, Cape Province', Journal of Social Research, Vol. 12, pp.27-48.

Appendix 1

Rates of population growth in comparison with coal exports and shipbuilding in Sunderland

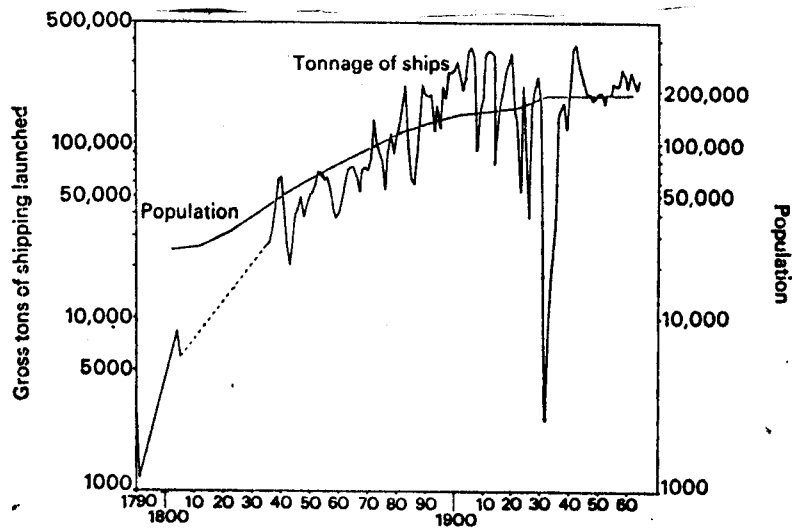
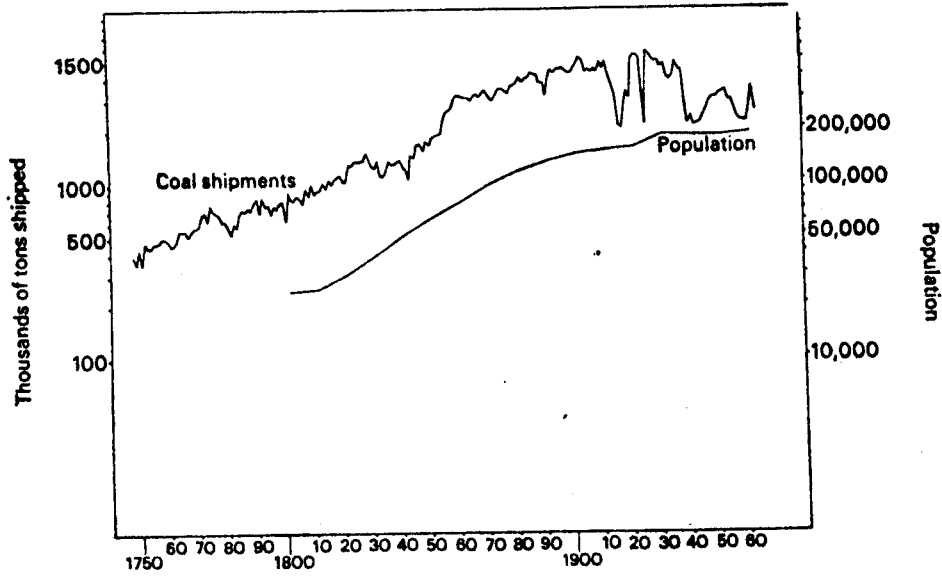

Source: Robson, B.T. (1969), 'Urban analysis : a study of city Structure', p. 80.

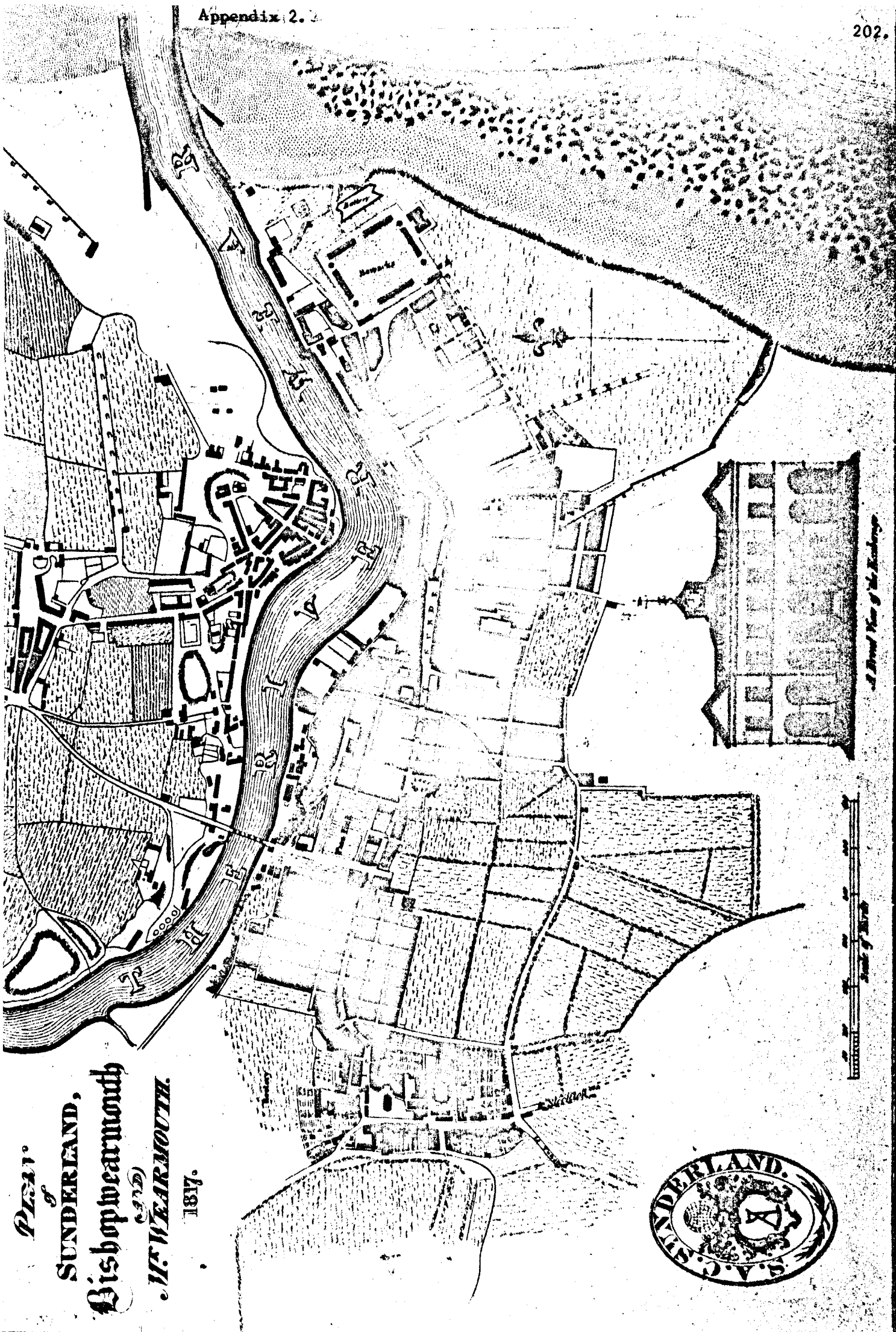

*Plan of*  
**SUNDERLAND,**  
*Bishopwearmouth*  
*and*  
**W. WEARMOUTH.**

1817.



*A. Small View of the Harbour*

*Published July 1st 1817 by George Colver*







## Appendix 6. Analysis of 1838 Rate Book

Owner/ Occ.	Prop- ties	Av. R.V.	Hou- ses	Shops	Work- Shops etc.	Instit- utions		
8/48 Covent Garden	38	£10.71	37	(5)	1	-	-	
6/39 George Street	33	£7.55	25	1+(4)	3	4	-	
6/33 Spring Garden Ln.	25	£7.66	21		3	1	-	
0/15 Dury Lane	11	£10.83	7	-	-	3	1	
0/15 Horns Lane	11	£10.77	3	-	2	6	-	
0/24 High Flag Lane	20	£6.38	18	(1)	-	2	-	
6/12 Maud's Lane	10	£8.1	7		1	2	-	
3/13 Grey Street	11	£8.18	6	2	1	2	-	
16/74 New Gray Street	55	£9.10	48	3(10)	3	1	-	
4/27 Golden Alley	24	£5.50	21	4(3)	-	-	-	
6/34 Lombard Street	27	£8.28	18	2+(1)	5	1	1	
11/44 Queen Street	33	£9.61	17	4(+5)	4	8	-	
1/9 Arras Lane	9	£3.50	5	2	-	2	-	
5/24 Barras Lane	19	£7.15	15	1+(11)	-	3	-	
6/52 Union Lane	38	£6.92	27	(1)	3	8		
0/60 New Market	58	£4.15	4	(58)	-	-	-	
6/47 Church Street W.	35	£9.86	16	(3)	4	13	2	
4/25 Church Street E.	21	£14.8	11	(1)	3	7	-	
7/24 Robinsons Lane W.	23	£8.2	16	3	4	-	-	
6/18 Robinsons Lane E.	17	£9.2	14		2	1		
9/38 Nesham Square	33	£8.1	28	(3)	2	3		
Low Street	152	£17.4	19	16	4.9.33.	28	-	
High Street N.	68	£22.9	5	6	H/S. 41 15	1		
High Street S.	92		14	13	50 15	-		
Boddlewell Lane	51	£11.9	6	13	21 6	4	-	

## Appendix 7. Analysis of 1850 Rate Book

NUMBERS

Street	Av.R.V.	Houses	Shops	Busin- ess	Warehouse Workshop Factory	Insts.
Fawcett Street	£30.9	47	(2)	-	-	1
John Street	£28.0	23		2		
Foyle Street	£17.0	15	-	-	-	
Frederick Street	£15.9	61	(6 houses listed but not rated)			
West Sunnyside	£21.3	14				
Sunnyside	£18.0	13		2	2	
Norfolk Street	£15.00	24			1	
Villiers Street	£16.6	42	(3)	4	1	
Nile Street	£10.6	50	5(1)	(1)	1	
Sans Street (inc. upper)	£10.1	27	(4)	1	2	
Sans Street	£11.7	11	(3)			
Union Street	£9.2	18	(2)	2	2	
North B. Street	£8.1	13	(1)	3	1	
Brougham Street	£10.4	10	-	2	-	
York Street	£6.4	5	(3)	1	1	
King Street	£7.9	11			1	
Walworth Street	£8.4	8	5(6)	2	4	
West Street	£12.2	3			2	
Crowtree Road	£8.7	24	(5)	3	3	
Bridge Street	£20.1	35	1(16)	2		
Bedford Street	£9.24	21	(4)	1	3	
Pann Bank.	£7.2	-	-	4	6	
West Wear Street	£6.7	17	(1)	2		
Lambton Street	£14.0	22	(1)	1	2	
Charles Street	£9.1	4	2(2)		1	
Sunderland Street	£11.8	13	(2)	3	1	
Cumberland Street	£3.50	1			5	
Queen Street	£13.48	12	1(1)	3	5(2)	
William Street	£6.5	7	1	2	7	

Appendix 8. Property use and residential structure of Fawcett Street, 1871.

<u>Property Number</u>	<u>Occupier</u>	<u>Property Number</u>	<u>Occupier</u>
4	Merchant	31	Solicitor
5	Draper	32	Photographer, Dentist, Sup. of Police
6	Landowner	33	Gentleman
7-9	Queens Hotel	34	Surgeon
8	Shipowner	35	Professor of Music
9	Shipowner	36	Surgeon
10	Shipbroker	37	Manufacturer
13-14	Chapel	38	Surgeon
16	Office Keeper and scholar	39	Registry Office
17	Head Accountant	40	Shipbuilder
18	Vestry Clerk and Lieutenant	41	Retired Colonel
19	Mariner	42	Magistrate
20	Mariner	43-53	
21	Chapel Keeper	54	Mariner
22	Surgeon	55	Shipbuilder
23,24	Commercial Hotel	56	Mariner
25	Store Manager	58	Mariner
26	Boarding School keeper	60	Retired Solicitor
27	Porter	61-64	Retired Solicitor
28	Ship's Carpenter		
29	Accountant		
30	Solicitor		

(Source: 1871 Census)

Appendix 9. Grid System and locational description

<u>Cell No.</u>	<u>Grid References</u>	<u>Streets/Area</u>
Cell 1	NZ 393566, 393567 394566, 394567	Albion Place. Mary Street Pt. of Stockton Road
Cell 2	NZ 394566, 394567 395566, 395567	Pts. of Derwent Street, Olive Street, Stockton Rd.
Cell 3	NZ 395566, 395567 396566, 396567	Pts. of Olive Street, Park Lane
Cell 4	NZ 393567, 393568 394567, 394568	Green Terrace, Part of Vine Place
Cell 5	NZ 394567, 394568 395567, 395568	Parts of Vine Place, Park Lane, Holmeside
Cell 6	NZ 395567, 395568 396567, 396568	Parts of Holmeside, Park Lane
Cell 7	NZ 396567, 396568 397567, 396568	Part of Holmeside
Cell 8	NZ 393568, 393569 394568, 394569	The Green
Cell 9	NZ 394568, 394569 395568, 395569	Parts of Crowtree Road, Maritime Terrace
Cell 10	NZ 395568, 395569 396568, 396569	Parts of Broughan Street, Maritime Terrace, Blandford Street, Holmeside.
Cell 11	NZ 396568, 396569 397568, 396569	Parts of Brougham Street, Blandford St. Holmeside, Waterloo Place.
Cell 12	NZ 398568, 398569 399568, 399568	Parts of John Street, Borough Road
Cell 14	NZ 399568, 399569 400568, 400569	Parts of Frederick St., Borough Road, Foyle Street
Cell 15	NZ 393569, 393570 394569, 394570	Church Lane, Carter Street, Crow Street
Cell 16	NZ 394569, 394570 395569, 395570	Parts of Crowtree Road, Walworth Way
Cell 17	NZ 395569, 395570 396569, 396570	Parts of Walworth Way, Market Square
Cell 18	NZ 396569, 396570 397569, 397570	Parts of Market Square
Cell 19	NZ 397569, 397570 398569, 398570	Parts of Fawcett Street, Athenaeum Street
Cell 20	NZ 398569, 398570 399569, 399570	Parts of John Street, Athenaeum Street
Cell 21	NZ 399569, 399570 400569, 400570	Parts of Frederick Stret, Athenaeum Street

Cell 22	NZ 400569, 400570 401569, 401570	Parts of Norfolk Street, Nile Street
Cell 23	NZ 401569, 401570 402569, 402570	Parts of Borough Road, Villiers Street
Cell 24	NZ 393570, 393571 394570, 394571	<b>Parts of High Street West,</b> Dun Cow Street
Cell 25	NZ 394570, 394571 395570, 395571	Parts of High Street West, Crowtree Rd., Walworth Way
Cell 26	NZ 395570, 395571 396570, 396571	Parts of Walworth Way
Cell 27	NZ 396570, 396571 397570, 397571	Parts of Union Street, Market Square
Cell 28	NZ 397570, 397571 398570, 398571	Parts of Fawcett Street, St. Thomas Street
Cell 29	NZ 398570, 398571 399570, 399571	Parts of John Street, St. Thomas Street, Frederick St.
Cell 30	NZ 399570, 399571 400570, 400571	Parts of St. Thomas Street, West Sunnyside, Norfolk Street
Cell 31	NZ 400570, 400571 401570, 401571	Parts of Coronation Street, Nile Street
Cell 32	NZ 401570, 401571 402570, 402571	Parts of Coronation Street, Villiers Streets, Sans Street
Cell 33	NZ 393571, 393572 394571, 394572	Gill Bridge Avenue
Cell 34	NZ 394571, 394572 395571, 395572	Parts of Castle Street, St. Mary's Way, High Street West
Cell 35	NZ 395571, 395572 396571, 396572	Parts of St. Mary's Way, High Street West
Cell 36	NZ 396571, 396572 397571, 397572	Parts of High Street West, Union Street
Cell 37	NZ 397571, 397572 398571, 398572	Parts of Bridge St, Fawcett St., High St. West, Bedford Street
Cell 38	NZ 398571, 398572 399571, 399572	Parts of John St., High Street W. Lambton Street
Cell 39	NZ 399571, 399572 400571, 400572	Parts of High Street West, West Sunnyside, Norfolk Street
Cell 40	NZ 400571, 400572 401571, 401572	Parts of Nile Street, Villiers Street
Cell 41	NZ 401571, 401572 402571, 402572	Parts of Sans Street
Cell 42	NZ 393572, 393573 394572, 394573	Gill Bridge Avenue

Cell 43	NZ 394572, 394573 395572, 395573	Pts. of Castle St., Dunning St. Cross Queen St.
Cell 44	NZ 395572, 395573 396572, 396573	Parts of St. Mary's Way, Matlock Street
Cell 45	NZ 396572, 396573 397572, 397573	
Cell 46	NZ 397572, 397573 398572, 398573	Part of West Wear Street, Bedford Street
Cell 47	NZ 398572, 398573 399572, 399573	Part of Lambton Street
Cell 48	NZ 399572, 399573 400572, 400573	Parts of William Street, East Cross Street
Cell 49	NZ 400572, 500573 401572, 401573	Parts of Sunderland St., High Street West
Cell 50	NZ 401572, 401473 402572, 402573	Parts of High Street W., Russell St. Sans Street

Appendix 10.

Table: (A) Observed land use change, 1894-1927

Initial Land Use, 1894	Terminal Use, 1927										TOTAL
	1	2	3	4	5	6	7	8	9	10	
Residential	52	2	6	5	5	0	0	4	0	1	76
Vacant	2	2	2	2	1	1	0	0	0	0	10
Retailing	3	1	73	0	3	0	1	2	0	0	83
Industrial	0	3	2	31	2	0	0	4	0	0	42
Institutions	2	1	1	0	62	0	1	1	0	0	68
Communications	0	0	0	0	0	142	0	0	0	0	142
Offices	0	1	2	0	0	0	13	0	0	0	16
Storage/Warehousing	0	0	0	7	0	0	1	16	0	1	25
Open Spaces	0	0	2	1	6	1	2	0	14	0	26
Car Park	0	0	0	6	0	0	0	2	0	6	14
Total	60	10	88	52	79	144	18	29	14	8	502

Table: (B) Expected, 1894 - 1927

	Expected										TOTAL
	1	2	3	4	5	6	7	8	9	10	
1	9.0837	1.5139	13.3227	7.8725	11.9602	21.8008	2.7251	4.3904	2.1195	1.2112	76.0000
2	1.1952	0.1992	1.7530	1.0359	1.5737	2.8685	0.3586	0.5777	0.2789	0.1594	10.0000
3	9.9203	1.6534	14.5498	8.5976	13.0618	23.8088	2.9761	4.7948	2.3147	1.3227	83.0000
4	5.0199	0.8367	7.3625	4.3506	6.6096	12.0478	1.5060	2.4263	1.1713	0.6693	42.0000
5	8.1275	1.3546	11.9203	7.0438	10.7012	19.5060	2.4382	3.9283	1.8964	1.0837	68.0000
6	16.9721	2.8287	24.8924	14.7092	22.3466	40.7331	5.0916	8.2032	3.9602	2.2629	142.0000
7	1.9124	0.3187	2.8048	1.6574	2.5179	4.5896	0.5737	0.9243	0.4462	0.2550	16.0000
8	2.9880	0.4980	4.3825	2.5896	3.9343	7.1713	0.8964	1.4442	0.6972	0.3984	25.0000
9	3.1076	0.5179	4.5578	2.6932	4.0916	7.4582	0.9232	1.5020	0.7251	0.4143	26.0000
10	1.6733	0.2789	2.4542	1.4502	2.2032	4.0159	0.5020	0.8088	0.3904	0.2231	14.0000
Total	60.0000	10.0000	88.0000	52.0000	79.0000	144.0000	18.0000	29.0000	14.0000	8.0000	502.0000

Table: (C)  $(\text{Observed} - \text{expected})^2$  — expected

	$(\text{Observed} - \text{expected})^2$										TOTAL
	1	2	3	4	5	6	7	8	9	10	
1	212.3201	0.1560	4.0249	1.0481	4.0504	21.8008	2.7251	0.0347	2.1195	0.0368	248.3165
2	0.5419	16.2792	0.0348	0.8974	0.2091	1.2171	0.3586	0.5777	0.2789	0.1594	20.5541
3	4.8275	0.2582	234.8091	8.5976	7.7508	23.8088	1.3121	1.6291	2.3147	1.3227	286.6306
4	5.0199	5.5938	3.9058	163.2398	3.2147	12.0478	1.5060	1.0207	1.1713	0.6693	197.3892
5	4.6196	0.0928	10.0042	7.0438	245.9134	19.5060	0.8484	2.1829	1.8964	1.0837	293.1912
6	16.9721	2.8287	24.8924	14.7092	22.3466	251.7608	5.0916	8.2032	3.9602	2.2629	353.9278
7	1.9124	1.4562	0.2309	1.6574	2.5179	4.5896	269.1501	0.9243	0.4462	0.2550	283.1400
8	2.9880	0.4980	4.3825	7.5112	3.9343	7.1713	0.0120	146.7022	0.6972	0.9084	174.8050
9	3.1076	0.5179	1.4354	1.0645	0.8901	5.5922	1.2229	1.5020	243.0328	0.4143	258.7797
10	1.6733	0.2789	2.4542	14.2744	2.2032	4.0159	0.5020	1.7546	0.3904	149.5803	177.1271
Total	253.9825	27.9598	286.1742	220.0434	293.0306	351.5105	282.7287	164.5312	256.3077	156.6928	2292.9613

Appendix 11.

Table: (A) Observed land use change, 1927-1948.

Initial Land Use,

Terminal Use, 1948

	1	2	3	4	5	6	7	8	9	10	TOTAL
Residential	49	2	6	6	2	0	0	0	2	1	68
Vacant	0	3	1	3	2	1	0	1	0	1	12
Retailing	1	6	76	3	0	1	2	0	1	2	92
Industrial	0	1	0	49	0	0	0	5	3	2	60
Institutions	0	2	2	1	79	0	0	1	0	0	85
Communications	0	0	0	0	0	157	0	0	0	0	157
Offices	0	0	0	0	0	1	15	0	0	2	18
Storage/Warehousing	0	2	2	9	0	0	0	18	0	0	31
Open Spaces	0	0	1	3	2	1	0	1	16	1	25
Car Park	0	0	0	6	0	0	0	0	3	1	10
Total	50	16	88	80	85	161	17	26	25	10	558

Table: (B) Expected, 1927 - 1948

	1	2	3	4	5	6	7	8	9	10	TOTAL
1	6.0932	1.9498	10.7240	9.7491	10.3584	19.6201	2.0717	3.1685	3.0466	1.2186	68.0000
2	1.0753	0.3441	1.8925	1.7204	1.8280	3.4624	0.3656	0.5591	0.5376	0.2151	12.0000
3	8.2437	2.6380	14.5090	13.1900	14.0143	26.5448	2.8029	4.2867	4.1219	1.6487	92.0000
4	5.3763	1.7204	9.4624	8.6022	9.1398	17.3118	1.8280	2.7957	2.6882	1.0753	60.0000
5	7.6165	2.4373	13.4050	12.1864	12.9480	24.5251	2.5896	3.9606	3.8082	1.5233	85.0000
6	14.0681	4.5018	24.7599	22.5090	23.9158	45.2993	4.7832	7.3154	7.0341	2.8136	157.0000
7	1.6129	0.5161	2.8387	2.5806	2.7419	5.1935	0.5484	0.8387	0.8065	0.3226	18.0000
8	2.7778	0.8889	4.8889	4.4444	4.7222	8.9444	0.9444	1.4444	1.3889	0.5556	31.0000
9	2.2401	0.7168	3.9427	3.5842	3.8082	7.2133	0.7616	1.1649	1.1201	0.4480	25.0000
10	0.8961	0.2867	1.5771	1.4337	1.5233	2.8853	0.3047	0.4659	0.4480	0.1792	10.0000
Total	50.0000	16.0000	88.0000	80.0000	85.0000	101.0000	17.0000	26.0000	25.0000	10.0000	558.0000

Table: (C)  $\frac{(\text{Observed}-\text{Expected})^2}{\text{Expected}}$

	1	2	3	4	5	6	7	8	9	10	TOTAL
1	302.1397	0.0013	2.0810	1.4418	6.7446	19.6201	2.0717	3.1685	0.3595	0.0392	337.6672
2	1.0753	20.5003	0.4209	0.9517	0.0162	1.7512	0.3656	0.3476	0.5376	2.8651	38.8314
3	6.3650	4.2847	260.6078	7.8723	14.0143	24.5825	0.2300	4.2867	2.3645	0.0748	324.6827
4	5.3763	0.3017	9.4624	189.7184	9.1398	17.3118	1.8280	1.7380	0.0362	0.7953	235.7078
5	7.6165	0.0785	9.7034	10.2684	336.9519	24.5251	2.5896	2.2131	3.8082	1.5233	399.2780
6	14.0681	4.5018	24.7599	22.5090	23.9158	275.4359	4.7832	7.3154	7.0341	2.8136	387.1366
7	1.6129	0.5161	2.8387	2.5806	2.7419	3.3861	380.8425	0.8387	0.8065	8.7226	404.8867
8	2.7778	1.3889	1.7071	4.6694	4.7222	8.9444	0.9444	189.7521	1.3889	0.5556	216.8509
9	2.2401	0.7168	2.1963	0.0952	0.8586	5.3519	0.7616	0.0233	197.6769	0.6800	210.6009
10	0.8961	0.2867	1.5771	14.5437	1.5233	2.8853	0.3047	0.4659	14.5360	3.7592	40.7780
Total	344.1678	32.5769	315.3544	254.6505	400.6286	383.7943	394.7212	210.1494	229.5483	21.8287	2586.4202

Appendix 12.

Table: (A) Observed land use change, 1948-1959.

Initial Land Use, 1948	Terminal Use, 1959										TOTAL
	1	2	3	4	5	6	7	8	9	10	
Residential	31	4	4	3	0	0	1	2	3	0	48
Vacant	0	2	3	4	0	1	0	5	1	0	16
Retailing	0	0	88	0	0	0	0	0	0	0	88
Industrial	0	4	2	63	1	1	0	7	2	0	80
Institutions	0	2	0	4	77	0	0	1	1	0	85
Communications	0	0	3	0	1	156	0	1	0	0	161
Offices	0	1	0	0	0	0	15	0	1	0	17
Storage/Warehousing	0	1	0	7	0	0	1	16	1	0	26
Open Spaces	0	0	1	5	0	0	0	1	17	1	25
Car Park	0	0	1	1	0	0	0	1	0	7	10
Total	31	14	102	87	79	158	17	34	26	8	556

Table: (B) Expected, 1948 - 1959

	Expected										TOTAL
	1	2	3	4	5	6	7	8	9	10	
1	2.6763	1.2086	8.8058	7.5108	6.8201	13.6403	1.4676	2.9353	2.2446	0.6906	48.0000
2	0.8921	0.4029	2.9353	2.5036	2.2734	4.5468	0.4892	0.9784	0.7482	0.2302	16.0000
3	4.9065	2.2158	16.1439	13.7698	12.5036	25.0072	2.6906	5.3813	4.1151	1.2662	88.0000
4	4.4604	2.0144	14.6763	12.5180	11.3669	22.7338	2.4460	4.8921	3.7410	1.1511	80.0000
5	4.7392	2.1403	15.5935	13.3004	12.0773	24.1547	2.5989	5.1978	3.9748	1.2230	85.0000
6	8.9766	4.0540	29.5360	25.1924	22.8759	45.7518	4.9227	9.8453	7.5288	2.3165	161.0000
7	0.9478	0.4281	3.1187	2.6601	2.4155	4.8309	0.5198	1.0396	0.7950	0.2446	17.0000
8	1.4496	0.6547	4.7698	4.0683	3.6942	7.3885	0.7950	1.5899	1.2158	0.3741	26.0000
9	1.3939	0.6295	4.5863	3.9119	3.5522	7.1043	0.7644	1.5288	1.1691	0.3597	25.0000
10	0.5576	0.2518	1.8345	1.5647	1.4209	2.8417	0.3058	0.6115	0.4676	0.1439	10.0000
Total	31.0000	14.0000	102.0000	87.0000	79.0000	158.0000	17.0000	34.0000	26.0000	8.0000	556.0000

Table: (C) (Observed - expected)<sup>2</sup> ÷ expected

	expected										TOTAL
	1	2	3	4	5	6	7	8	9	10	
1	299.7596	6.4467	2.6227	2.7091	6.8201	13.6403	0.1490	0.2980	0.2542	0.6906	333.3904
2	0.8921	6.3314	0.0014	0.8944	2.2734	2.7667	0.4892	16.5299	0.0847	0.2302	30.4935
3	4.9065	2.2158	319.8302	13.7698	12.5036	25.0072	2.6906	5.3813	4.1151	1.2662	391.6863
4	4.4604	1.9572	10.9488	203.5818	9.4549	20.7778	2.4460	0.9083	0.8102	1.1511	256.4966
5	4.7392	0.0092	15.5935	6.5033	348.9968	24.1547	2.5989	3.3902	2.2264	1.2230	409.4353
6	8.9766	4.0540	23.8407	25.1924	20.9196	265.6653	4.9227	7.9469	7.5288	2.3165	371.3635
7	0.9478	0.7642	3.1187	2.6601	2.4155	4.8309	403.3918	1.0396	0.0529	0.2446	419.4660
8	1.4496	0.1821	4.7698	2.1126	3.6942	7.3885	0.0529	130.6035	0.0383	0.3741	150.6657
9	1.3939	0.6295	2.8044	0.3027	3.5522	7.1043	0.7644	0.1829	214.3752	1.1397	232.2491
10	0.5576	0.2518	0.3796	0.2038	1.4209	2.8417	0.3058	0.2468	0.4676	326.6939	333.3695
Total	328.0833	22.8420	383.9098	257.9299	412.0511	374.1774	417.8113	166.5273	229.9535	335.330	2928.6158

Appendix 13.

Table: (A) Observed land use change, 1959-1975.

Initial Land Use, 1959	Terminal Use, 1975										TOTAL
	1	2	3	4	5	6	7	8	9	10	
Residential	3	0	3	0	3	4	0	4	12	2	31
Vacant	0	1	3	0	0	2	0	3	4	1	14
Retailing	0	1	74	0	0	11	2	1	13	0	102
Industrial	0	0	8	40	4	11	0	5	17	2	87
Institutions	0	0	8	0	57	5	1	0	6	2	79
Communications	0	2	2	1	0	148	0	1	0	1	155
Offices	0	0	0	0	1	1	15	0	0	0	17
Storage/Warehousing	0	4	4	1	0	6	0	11	4	4	34
Open Spaces	0	0	5	0	1	4	0	3	12	1	26
Car Park	0	0	1	0	0	2	0	0	0	5	8
Total	3	8	108	42	66	194	18	28	68	18	553

Table: (B) Expected, 1959 - 1975

	Expected, 1959 - 1975										TOTAL
	1	2	3	4	5	6	7	8	9	10	
1	0.1682	0.4485	6.0542	2.3544	3.6998	10.8752	1.0090	1.5696	3.8119	1.0090	31.0000
2	0.0759	0.2025	2.7342	1.0633	1.6709	4.9114	0.4557	0.7089	1.7215	0.4557	14.0000
3	0.5533	1.4756	19.9204	7.7468	12.1736	35.7830	3.3201	5.1646	12.5425	3.3201	102.0000
4	0.4720	1.2586	16.9910	6.6076	10.3834	30.5208	2.8318	4.4051	10.6980	2.8318	87.0000
5	0.4286	1.1429	15.4286	6.6000	9.4286	27.7143	2.5714	4.0000	9.7143	2.5714	79.0000
6	0.8409	2.2423	30.2712	11.7722	18.4991	54.3761	5.0452	7.8481	19.0597	5.0452	155.0000
7	0.0922	0.2459	3.3201	1.2911	2.0289	5.9638	0.5533	0.8608	2.0904	0.5533	17.0000
8	0.1844	0.4919	6.6401	2.5823	4.0579	11.9277	1.1067	1.7215	4.1808	1.1067	34.0000
9	0.1410	0.3761	5.0778	1.9747	3.1031	9.1212	0.8463	1.3165	3.1971	0.8463	26.0000
10	0.0434	0.1157	1.5624	0.6076	0.9548	2.8065	0.2604	0.4051	0.9837	0.2604	8.0000
Total	3.0000	8.0000	108.0000	42.0000	66.0000	194.0000	18.0000	28.0000	68.0000	18.0000	553.0000

Table: (C) (Observed - expected)<sup>2</sup> ÷ expected

	(Observed - expected) <sup>2</sup> ÷ expected										TOTAL
	1	2	3	4	5	6	7	8	9	10	
1	47.6843	0.4485	1.5408	2.3544	0.1324	4.3465	1.0090	3.7632	17.5880	0.9732	79.8403
2	0.0759	3.1400	0.0258	1.0633	1.6709	1.7258	0.4557	7.4053	3.0156	0.6501	19.2286
3	0.5533	0.1533	146.8140	7.7468	12.1736	17.1645	0.5249	3.3582	0.0167	3.3201	191.8254
4	0.4720	1.2586	4.7577	168.7532	3.9243	12.4853	2.8318	0.0804	3.7124	0.2443	198.5199
5	0.4286	1.1429	3.5767	6.0000	240.0195	18.6163	0.9603	4.0000	1.4202	0.1270	276.2914
6	0.8409	0.0262	26.4034	9.8571	18.4991	161.1999	5.0452	5.9755	19.0597	3.2434	250.1504
7	0.0922	0.2459	3.3201	1.2911	0.5218	4.1315	377.1710	0.8608	2.0904	0.5533	390.2782
8	0.1844	25.0213	1.0497	0.9695	4.0579	2.9459	1.1067	50.0083	0.0078	7.5642	92.9157
9	0.1410	0.3761	0.0012	1.9747	1.4253	2.8753	0.8463	2.1530	24.2378	0.0279	34.0587
10	0.0434	0.1157	0.2024	0.6076	0.9548	0.2318	0.2604	0.4051	0.9837	86.2373	90.0722
Total	50.5161	31.9285	187.6919	200.6178	283.3795	225.7228	390.2113	78.0096	72.1324	102.9710	1623.1809

Appendix 14. Land use survey system, (1970).

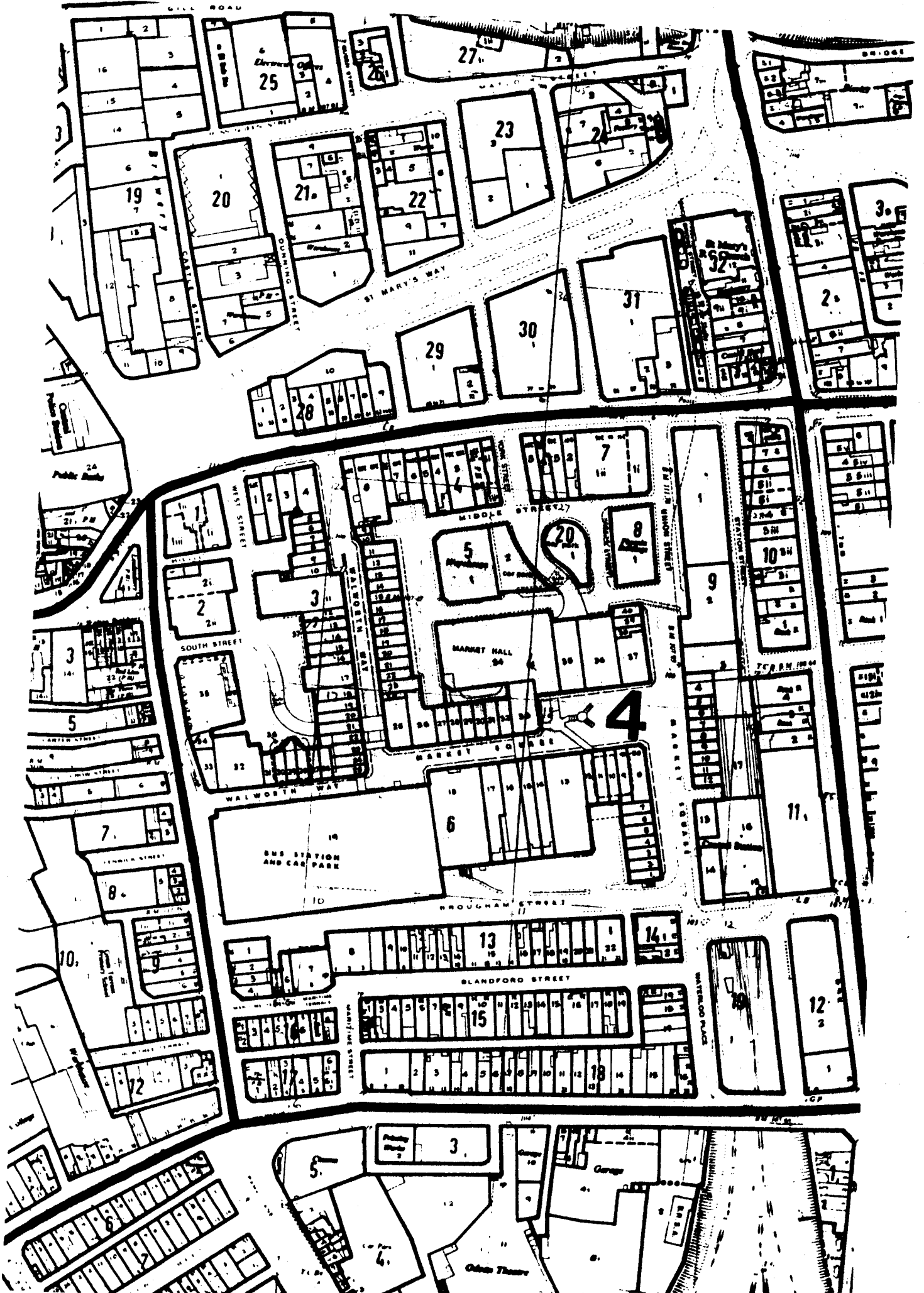

## Appendix 15.

## Floor Space Totals

Cell No.	Shop	Offices	Services	Total	% Shops	% Offices	% Services
1	1326	270	1041	2637	50.3	10.2	39.5
2	3584	200	1401	5185	69.1	3.9	27.0
3	286	-	1243	1529	18.7	-	81.3
4	835	427	300	1562	53.5	27.3	19.2
5	4843	87	1182	6112	79.2	1.4	19.3
6	391	-	4434	4825	8.1	-	91.9
7	421	-	2453	2875	14.7	-	85.3
8	243	-	1297	1540	15.8	-	84.2
9	2299	300	-	2599	88.5	11.5	-
10	6659	196	1547	8402	79.3	2.31	18.4
11	7458	512	610	8580	86.9	6.0	7.1
12	11472	-	1632	13104	87.5	-	12.5
13	284	1424	3583	5291	5.4	26.9	67.7
14	1750	1620	556	3926	44.6	41.3	14.2
15	43	-	674	717	6.0	-	94.0
16	2976	-	1190	4166	71.4	-	28.6
17	4900	64	1658	6622	74.0	1.0	25.0
18	3690	323	339	4352	84.8	7.4	7.8
19	2344	1334	1070	4748	49.4	28.1	22.5
20	607	5024	298	5929	10.2	84.7	5.0
21	136	2131	1650	3917	3.5	54.4	42.1
22	-	199	1361	1560	-	12.8	87.2
23	-	-	230	230	-	-	100.0
24	1115	-	1959	3074	36.3	-	63.7
25	5297	-	1161	6458	82.0	-	18.0
26	519	-	540	1059	49.0	-	51.0
27	6318	225	1851	8394	75.2	2.7	22.1
28	9995	3207	2710	15912	62.8	20.2	17.0
29	1148	2720	2613	6481	17.7	42.0	40.3
30	295	2276	3320	5891	5.0	38.6	56.4
31	47	246	308	601	7.8	40.9	51.2
32	93	-	-	93	10.0	-	-
33	-	-	-	-	62.8	-	37.2

## Appendix 16. Land uses by floor levels : (A) core (B) non-core

A. CORE

Land Use	B	G	1	2	3	4	TOTAL
Retailing	6,277	46,522	30,161	16,000	6,320	1,556	106,836
Financial	1,557	6,979	5,948	3,073	300	0	17,857
General Offices	509	1,151	1,190	1,171	137	0	4,158
Services	7,989	11,812	10,981	9,059	2,881	1,857	44,579
							(173,430)
Residential	1,085	542	2,173	3,302	1,228	14,062	22,392
Institutions	635	903	585	610	0	0	2,733
Vacant	2,354	7,468	10,565	8,371	1,497	292	30,547
Industry	745	2,528	898	512	0	0	4,683
Warehouse/Storage	2,390	3,191	4,697	3,345	883	708	15,214
TOTAL	23,541	81,093	67,191	45,443	13,246	18,475	75,569
							(248,999)
<u>B. NON-CORE</u>							
Land Use	B	G	I	2	3	4	TOTAL
Retailing	127	11,068	3,724	749	0	0	15,668
Financial	271	614	214	401	0	0	1,500
Gen. Offices	297	459	317	60	0	0	1,133
Services	1,130	13,110	7,243	5,844	1,056	0	28,383
Residential	390	4,408	6,868	3,133	814	7,595	23,208
Institutions	1,553	7,265	5,073	3,593	2,275	0	19,759
Vacant	824	9,197	8,558	5,121	1,792	309	25,801
Industry	2,307	25,469	15,279	6,688	1,365	0	51,108
Warehouse/Storage	2,260	14,270	8,052	3,377	361	0	28,320
TOTAL	9,159	85,860	55,328	28,966	7,763	7,904	(194,880)

## Appendix 17.

Distribution of Central and Non Central Land Use  
by Floor Levels (in sq. metres)

Floor Levels

Cell No.	Basem't	Grid	1st Floor	2nd Floor	3rd Floor	Total	Grand Total
1	0	1,744	854	39	0	2,637	6,338
	85	1,712	1,568	336	0	3,701	
2	250	2,620	1,724	591	0	4,504	9,689
	0	1,212	2,113	1,179	0		
3	31	4,682*	396	152	0	5,261	6,168*
	0	347	250	310	0		
4	0	1,070	358	134	0	1,562	15 297
	2,275	2,935	3,427	2,823	2,275		
5	0	2,807	2,086	1,023	196	6,112	8,796
	50	794	1,331	509	0		
6	500	1,397	976	976	976	4,825	8,012
	0	1,910	151	150	976		
7	0	1,003	794	601	476	2,874	7,964
	0	3,033	1,107	950	0		
8	0	728	485	327	0	1,540	6,030
		2,008	2,125	357	0		
9	0	1,850	749	0	0	2,599	7,095
	589	1,163	1,561	1,183	0		
10	174	4,128	3,180	920	0	8,402	11,030
	417	646	731	417	417		
11	0	4,510	2,852	1,218	0	8,580	9,335
	0	0	572	183	0		
12	2,257	2,713	2,554	2,012	3,568**	13,104	13,530
	0	0	0	436	0		
13	1,169	1,415	1,461	1,246	0	5,291	5,760
	263	103	103	0	0		
14	679	1,796	782	669	0	3,926	10,209
	654	2,090	2,255	1,065	219		
15	0	463	254	0	0	717	3,628
	0	1,632	921	358	0		
16	0	2,593	1,873 (1)	2,867 (1)	0 (1)	7,333 (1)	(1) 17,226
	0	721	988	509	7,675 (1)		
17	0	3,471	3,451	2,867	0	9,789	12,416
	0	429	2,198	0	0		

18	0	2,406	886 2,354 <sup>2</sup>	0 467 <sup>2</sup>	0 7,471 <sup>2</sup>	2,292 10,918 <sup>2</sup>	14,210 <sup>(2)</sup>
19	5,222 <sup>3</sup> 0	3,065 <sup>3</sup> 0	1,271 422	435 1,443	359 1,000 <sup>4</sup>	10,352 2,865	13,217 <sup>3</sup>
20	874 1,195	2,407 1,443	1,997 996	651 1,084	0 0	5,929 4,718	10,647
21	499 1,577	1,510 526	1,527 560	381 836	0 0	3,917 3,499	7,416
22	39 404	689 2,007	660 1,466	172 743	0 0	1,560 4,620	6,180
23	0 188	730 2,688	500 2,088	500 969	500 503	2,230 6,436	8,666 <sup>5</sup>
24	0 0	1,700 2,461	919 1,451	375 804	80 31	3,074 4,747	7,821
25	386 0	2,882 786	2,541 <sup>6</sup> 1,042 <sup>6</sup>	649 336 <sup>6</sup>	0 3,718 <sup>6</sup>	6,458 5,962 <sup>6</sup>	12,420 <sup>6</sup>
26	0 0	235 2,250	342 <sup>1</sup> 1,621 <sup>2</sup>	715 <sup>1</sup> 239 <sup>2</sup>	6,131 <sup>1</sup> 3,818 <sup>2</sup>	2,923 <sup>1</sup> 7,928 <sup>2</sup>	10,851 <sup>1,2</sup>
27	0 0	3,191 92	2,640 92	1,057 848	1,506 <sup>3</sup> 0	8,394 1,032	9,426
28	1,143 0	4,768 54	3,800 168	3,433 501	2,769 <sup>4</sup> 283	5,912 1,006	16,918
29	699 34	1,143 781	1,077 827	793 852	211 1,000 <sup>5</sup>	3,923 3,494	7,417
30	887 486	1,135 1,203	1,063 1,164	257 1,205	49 1,065	3,391 5,123	9,514
31	121 390	331 3,856	149 2,032	0 443	0 0	601 6,721	7,322
32	0 0	93 3,072	0 1,656	0 623	0 0	93 5,351	5,444
33	0 3,186	0 1,938	0 1,888	0 400	0 0	0 7,412	7,412
34	0 0	901 1,728	550 1,191	432 807	0 0	1,883 3,726	5,719
35	521 0	3,710 130	3,168 656	2,663 463	0 0	10,062 1,249	11,311
36	1,152 0	5,271 0	4,772 400	4,535 478	1,463 0	17,193 878	18,071

37	283 501	3,236 2,443	1,323 1,716	1,124 1,866	545 706	6,228 7,232	13,460
38	355 346	2,417 1,293	1,476 2,019	1,068 1,211	0 192	5,316 5,061	10,377
39	171 765	2,475 1,304	1,514 1,054	513 829	0 0	4,673 3,952	8,625
40	102 0	476 3,092	414 2,079	155 1,150	0 446	1,147 6,767	7,914
41	0 0	0 2,338	0 1,681	0 920	0 494	0 5,433	5,433
42	0 0	0 3,615	0 3,415	0 2,626	0 0	0 9,656	9,656
43	0 0	0 5,046	0 2,906	0 1,065	0 250	0 9,267	9,267
44	0 0	0 547	0 78	0 20	0 0	0 645	645
45	0 0	50 3,117	0 937	0 375	0 27	50 4,456	4,506
46	0 123	441 2,321	319 1,690	252 1,147	0 1,351	1,012 6,632	1,644
47	450 801	1,641 1,831	935 2,258	0 166	0 0	3,026 5,056	8,082
48	0 607	629 3,044	0 2,283	0 501	0 0	629 6,435	7,064
49	0 304	1,310 1,329	323 1,204	72 1,107	0 537	1,705 4,484	6,189
50	537 0	824 1,686	307 800	307 300	0 0	1,975 2,786	4,761

**Notes:**

- (1) Figures include multi-storey car park.
- (2) Figures include high rise residential flats.
- (3) Includes 449 sq. metres of floorspace at 4th floor level.
- (4) Includes 342 " " " " " " " "
- (5) Includes 500 " " " " " " " "
- (1) Includes residential space in Solar House -- 8,593 sq. metres upto 18 storeys (aggregated to 3rd floor figures)
- (2) Includes residential space (8,405 sq. metres) in high-rise central area flats. Also includes vacant space later occupied by retail/ service uses.
- (3) Figures include British Rail space.
- (4) Includes 500 sq. metres at 4th floor level.
- (5) Includes Social Security offices (2,000 sq. metres).
- (6) Includes residential space (4296 sq. metres) in central area flats.
- (1) First row for each cell refers to 'central' land uses.
- (2) Second row for each cell refers to 'non-central' land use.
- \* Figures include Park Lane Bus Station - 4581 sq. metres.
- \*\* Includes 1,556 sq. metres at a 4th level.
- (1) Includes 476 sq. metres at 4th and 5th floor levels.

Appendix 18. The National Gazetteer System:

This Appendix describes the National Gazetteer Pilot Study which was established in December 1972 by the Coordinating Committee on Locational Referencing. The committee includes representatives from Government Departments, nationalised industries and Local Authorities. The project emanated from two published reports: (a) General Information system for Planning (H.M.S.O., 1968) and (b) Manual on Point Referencing Properties and Parcels of Land (D.E., 1970). The broad purpose of the Gazetteer System is to examine the efficacy of spatial referencing so that data and information can be located by means of identifier and locator keys.<sup>(1)</sup> The Pilot Study commenced early in 1973 to build five gazetteers in the Tyne and Wear county, one gazetteer for each of the emerging metropolitan districts - Newcastle, North Tyneside, Gateshead, South Tyneside and Sunderland. Each gazetteer is the responsibility of the respective local authority planning department.<sup>(2)</sup>

The Gazetteer consists of two parts: a file part and a cartographic part. The file part contains information for each individual property and piece of land.\* These are termed the basic spatial unit (B.S.U.). A B.S.U. can be (i) a rateable hereditament, (ii) a property equivalent to a hereditament but unrated such as a tract of derelict land, (iii) a grouping of hereditaments such as a block of garages with shared access, and (iv) a B.S.U. where a single hereditament is split on the ground into two or more parts eg. a shop with departments on either side of a road. In all cases, however, a B.S.U. is spatially unique with no two or more on the same piece of land. Furthermore, a B.S.U. possesses a clearly recognisable boundary and contains a generally homogeneous activity.<sup>(3)</sup>

Once the pre survey preparations and checks are completed to establish the exact number of the B.S.U.s each B.S.U. is described by a set of attributes:

- (i) a unique property number (identifier)
- (ii) a postal address
- (iii) a land use activity
- (iv) a cartesian coordinate reference against the national grid (locator). This is a one metre reference placed at the centibid of the B.S.U. as determined visually.

Following the creation and manual survey stage there comes the ongoing, regular monthly updating of the gazetteer. This is achieved by using normal routine administrative records available in various department. The rating, building and housing departments are the most

obvious sources of the information required. The data on the inventory are then made available in either digital <sup>(4)</sup> or print form. An example of the latter is given below from central Sunderland:

<u>Property No.</u>	<u>Address</u>	<u>Land-use</u>
12 0570 014 00	14 + 15 Borough Road	0951-Social Club
<u>Map Q.</u>	<u>1 m. Grid Ref.</u>	<u>Date</u>
4056 NW.	440 037 556882	03.74

The other part of the Gazetteer is in cartographic form and involves maintaining monthly 1/1250 or 1/2500 scale sheets, optional monochrome land use overlays and map records.

The Gazetteer's land use classification <sup>(5)</sup> is a detailed digital and logical sequence arranged into orders, groups, classes and sub-classes. This allows aggregation from basic class levels to two upper levels: group level (aggregation of classes) and order level (aggregation of groups). A numerical key which facilitates this and simplifies mechanical manipulation is a 4 digit code : the first 2 digits corresponding to the order, the first 3 digits denoting the group and the combination of all 4 digits denoting the class. An illustration of the system is provided:

<u>Order</u>	<u>Group</u>	<u>Class</u>	<u>Sub-Class</u>
01 Industrial	010 Manufacturing Food Processing	0110 Manufacturing Industry	01100 Chemicals 01101 Metal etc.

There are 11 orders: residential, industrial, storage, offices, retail, wholesale, health, education, transport, leisure, community services and miscellaneous. Each order potentially contains 10 groups each comprising 10 classes. In practice only a fraction of the theoretical capacity is used. <sup>(6)</sup>

The Committee recommended that the Gazetteer should be accessible to the public, be up-to-date, meet the reasonable demands of users for locational codes and should be compatible with other users.

References: Introduction to Gazetteers.

- (1) Memorandum, 1, Coordinating Committee on Locational Referencing. DOE, March 1974.
- (2) Report of the Gazetteer Working Party. Coordinating Committee on Locational Referencing, DOE, October 1972.
- (3) Memorandum 2m Monthly updating of Gazetteer File and Maps. Coordinating Committee on Locational Referencing, DOE, March 1974.

- (4) J. Spicer - National Gazetteer Pilot Study - British Urban and Regional Information Systems Association BURISA 17, June, 1975.
- (5) Land Use Classification - National Gazetteer Pilot Study, Jan. 1975.
- (6) Memorandum 7, Coding, Digitising and Land Use. Coordinating Committee on Locational Referencing, November, 1974.

#### Appendix 19. Classification of Commercial Activities

The following definition of commercial activities was used in Chapter 6. It has been based on other standard systems but adapted to the particular needs of this study of central Sunderland.

##### A. RETAILERS

Confectioners/Bakers - this heading includes outlets selling bread and flour confectionery but excludes both retailers with significant sales of groceries and outlets with a dominant industry in bakery production.

Jewellers/Watchmakers - includes shops selling or repairing new or second hand jewellery, or watches or clocks.

Fancy Goods/toys/games - miscellaneous novelties, souvenirs, sports goods and toys.

Clothes and Tailors - establishments specialising in the sale of men and women's wear, including bespoke tailors which produce for a retail market. The heading also includes drapers shops, children's wear, fur and millinery.

Grocery/Drinks - covers small general stores, provision dealers and 'dairies'.

Footwear/Leather - shops selling boots and shoes for men, women and children and handbags and other leather based products.

Confectioner/Tobacconist/Newsagent - this heading includes three retailers selling sweets, cigarettes, newspapers, periodicals, stationery equipment.

Butcher/Fishmonger - traders selling meat, fish, poultry.

House Furnishings - includes domestic furniture, bedding, floor coverings.

Electrical - establishments selling electrical appliances and supplies, radio and television sets. Record and Music shops were not included.

Cycle/Auto-shops - includes retailers of cycles, motor accessories and repairs, prams.

Fruit/Flower/Greengrocer - establishments whose main sales are derived from greengrocery, fruit and flowers.

Chemist - shops selling pharmaceutical products, perfumes, cosmetics and some household goods, including toiletries, photographic.

Music Shop - selling record players, records, musical instruments, sheet music.

Pet/Garden Shops - including retailers of seeds, plants, garden equipment, pets, and pet foods.

Antique/Art Dealers - this group includes the second hand, bric a brac shops and the high quality antique/art-dealer.

Department Stores - stores which are large and sell a very wide range of goods including food and non-food items.

Wallpaper/Paint/D.I.Y. Shops - decorating supplies, hardware equipment, ironmongers are included in this category.

Office Equipment - retailers selling office equipment, office stationery and furniture.

Other - this heading covers a miscellaneous collection of retailers not covered under the above headings, eg. showrooms (gas and electricity), surgical and scientific goods, pawnbrokers, sub-post offices with minor retail sales.

## B. OFFICES

Chartered Accountants - this heading covers those offices dominantly concerned with the professional keeping of accounts.

Financiers - offices which conduct various financial operations including credit facilities/money lending, stock brokers.

Building Societies - offices which fund capital to members.

Estate Agents - establishments which conduct the selling and buying of properties, including valuations.

Solicitors - offices which are concerned with legal matters, including conveyancing.

Banks - institutions for the custody of money, handling financial transactions and credit facilities.

Professional - includes surveyors, architects and various consultants.

Other - this heading covers a collection of office establishments not defined in the above categories.

C. SERVICES

Opticians - this heading includes the establishments which make and sell optical instruments, particularly spectacles.

Dentist - establishments which exist to treat diseases of the teeth, extract them and insert artificial ones.

Hairdressers - this heading covers ladies and gentlemen's hair dressing salons and beauty parlours.

Motoring Schools - establishments which exist to teach the public to drive.

T.V. Rentals - establishments whose main receipts are from rentals of radio and television sets and not having a significant sale of radios and televisions.

Dry Cleaners - traders undertaking cleaning of clothes and not having a significant sales of clothes.

Commissioners(Bookmakers) - outlets which exist to take bets on a race, a meeting or any other gambling occasion.

Fuel Merchant - traders who deliver solid and liquid fuel to domestic consumers usually coal, coak and oil.

Entertainment - this heading includes bingo, clubs, theatres, cinemas, dance halls, bowling alleys and other establishments which are predominantly concerned with providing organised entertainment for the public.

Agencies - this heading includes establishments which exist to promote a variety of activities such as travel, musical groups. campaigns etc.

Appendix 20

FACTORS AFFECTING THE LOCATION AND MIGRATION OF  
SHOPS, OFFICES AND BUSINESSES

A. Have you occupied these premises for:

- 0 - 1 year
- 1 - 5 year
- 6 - 10 years
- 11 - 20 years
- + 20 years

B. Did you move to these premises from elsewhere in Sunderland Yes/No

If yes, give address .....

If no, give the town/county .....

C. Did you move from your previous premises for any of the following reasons: (tick each one)

- (i) building too small
- (ii) building too old
- (iii) poor accessibility from your clients
- (iv) rents and rates too high
- (v) compulsory order on premises
- (vi) isolated from transport/communications
- (vii) isolated from business contacts
- (viii) too far from place of residence for employees
- (ix) premises in a 'poor area' environmentally
- (x) other reason (specify, if possible)

D. Which of the following tenure systems applies to your firm?

- owner occupied
- rented property
- leasehold (long)
- leasehold (short)
- other

E. Please list the advantages/disadvantages of the present location of your business, as you see them (on the reverse side).